

Air Preparation Products
Dryer Series

PRD Refrigeration	M2-M5
DD Disposable	M6
DD Inline Desiccant	M7-M8
DAS Regenerative Desiccant	M9-M12
PTW Heatless Desiccant	M13-M16



PRD Refrigeration Dryer Series



Refrigeration

Disposable

Desiccant

PRD10 - PRD175

- “Plug & Play” design for easy installation and operation (PRD10 - PRD175)
- Small space saving design
- Oversized demister separator resulting in excellent liquid removal over all operating conditions
- Low pressure differential across the dryer (1.45 psig average)
- Oversized condenser to operate in ambients to 122°F (50°C)
- All models incorporate a dewpoint indicator

PRD200 - PRD2400

- Optimum dewpoint levels for highest system performance
- Advanced patented design solutions
- High reliability, easy to use and maintain
- Unique 4-in-1 SmartPack heat exchanger
- Integral drain
- Extremely low pressure drop design
- SmartControl energy saving function
- Excellent dewpoint performances
- Advanced compliant scroll compressor

PRD Series

Capacity SCFM @ 100 psig (m³/min @ 6.9 bar)	Primary voltage	Part number	Pipe size	Recommended filtration		
				Bulk separator	Pre-filter (5µ particulate)*†	Post-filter (.01µ coalescing)
10 (17)	115V/1ph/60Hz	PRD10-115160	1/2" NPT-F	P3TFA94WCAN	P32FB94ESAN	P32FB94DSAN
15 (26)	115V/1ph/60Hz	PRD15-115160	1/2" NPT-F	P3TFA94WCAN	P32FB94ESAN	P32FB94DSAN
25 (43)	115V/1ph/60Hz	PRD25-115160	1/2" NPT-F	P3TFA94WCAN	P32FB94ESAN	P32FB94DSAN
35 (60)	115V/1ph/60Hz	PRD35-115160	1/2" NPT-F	P3TFA94WCAN	P32FB94ESAN	P32FB94DSAN
50 (85)	115V/1ph/60Hz	PRD50-115160	3/4" NPT-F	P3TFA96WDAN	P33FA96ESAN	P33FA96DSAN
75 (127)	115V/1ph/60Hz	PRD75-115160	3/4" NPT-F	P3TFA96WDAN	P33FA96ESAN	P33FA96DSAN
100 (170)	115V/1ph/60Hz	PRD100-115160	3/4" NPT-F	P3TFA96WDAN	P3NFA96GSA †	P3NFA96DSA
125 (212)	115V/1ph/60Hz & 230V/1ph/60Hz	PRD125-115160 PRD125-230160	1-1/2" NPT-F	P3TFA9BWWGAN	P3NFA9PGSA †	P3NFA9PDSA
150 (255)	115V/1ph/60Hz & 230V/1ph/60Hz	PRD150-115160 PRD150-230160	1-1/2" NPT-F	P3TFA9BWWGAN	P3NFA9PGSA †	P3NFA9PDSA
175 (297)	115V/1ph/60Hz	PRD175-230160	1-1/2" NPT-F	P3TFA9BWWGAN	35F77BAP	35F77EAP
200 (425)	230V/1ph/60Hz	PRD200-230160	1-1/2" NPT-F	P3TFA9BWWGAN	35F77BAP	35F77EAP
250 (425)	230V/3ph/60Hz & 460V/3ph/60Hz	PRD250-230360 PRD250-460360	1-1/2" NPT-F	P3TFA9BWWGAN	35F77BAP	35F77EAP
325 (552)	230V/3ph/60Hz & 460V/3ph/60Hz	PRD325-230360 PRD325-460360	2" NPT-F	P3TFA9CWHAN	35F87BAP	35F87EAP
400 (680)	230V/3ph/60Hz & 460V/3ph/60Hz	PRD400-230360 PRD400-460360	2" NPT-F	P3TFA9CWHAN	35F87BAP	35F87EAP
500 (849)	230V/3ph/60Hz & 460V/3ph/60Hz	PRD500-230360 PRD500-460360	2" NPT-F	P3TFA9CWHAN	35F87BAP	35F87EAP
700 (1189)	230V/3ph/60Hz & 460V/3ph/60Hz	PRD700-230360 PRD700-460360	3" NPT-M	P3TFA9EWKAN	43FN7BAP	43FN7EAP
800 (1359)	230V/3ph/60Hz & 460V/3ph/60Hz	PRD800-230360 PRD800-460360	3" NPT-M	P3TFA9EWKAN	43FN7BAP	43FN7EAP
1000 (1700)	460V/3ph/60Hz	PRD1000-460360	3" NPT-M	P3TFA9EWKAN	43FN7BAP	43FN7EAP
1200 (2039)	460V/3ph/60Hz	PRD1200-460360	3" NPT-M	P3TFA9EWKAN	43FN7BAP	43FN7EAP
1600 (2718)	460V/3ph/60Hz	PRD1600-460360	4" Flg.	P3TFAFFW2AN	P3TFAFFQ2AN*	P3TFAFFD2AN
2000 (3400)	460V/3ph/60Hz	PRD2000-460360	6" Flg.	P3TFAFGW3AN	P3TFAFGQ3AN*	P3TFAFGD3AN
2400 (4078)	460V/3ph/60Hz	PRD2400-460360	6" Flg.	P3TFAFGW3AN	P3TFAFGQ3AN*	P3TFAFGD3AN

Most popular.

* 1µ coalescing
† 40 micron



For inventory, lead times, and kit lookup, visit www.pdnplu.com

PlusPack heat exchanger (patent pending)

The revolutionary PlusPack features a 3-in-1 aluminum design with integral air connections. All models include an air-to-air freecooler, while the unique “slowflow” demister ensures perfect dewpoints whatever the operating conditions.

Demister separator

A high capacity demister separator is employed for the removal of condensed liquids. This lowers the air velocity which maximizes the condensate separation from the air, even when the dryer is not operating at maximum flow. This design also ensures the differential pressure across the dryer is kept to a minimum.

Refrigerant condenser

Oversized high efficiency air cooled condenser. Re-positioned to improve reliability and reduce the risk of dirt contamination.

Condensate drain niche

The PRD Refrigeration Dryer range comes standard with a level sensing automatic float drain. Other drains are available upon request. The positioning of the drain niche allows for easy access to the drain without the requirement of removing panels.

Refrigerant compressor

Maintenance free hermetically sealed refrigerant compressor. Low refrigerant charge eliminates the requirement for pre-heating on start up & prevents any liquid refrigerant returns.



Assured quality & performance

Every dryer undergoes sophisticated testing, including dewpoint tests with compressed air flow. Multiple helium leak testing, again on every dryer, ensures years of trouble-free operation.

Energy efficiency

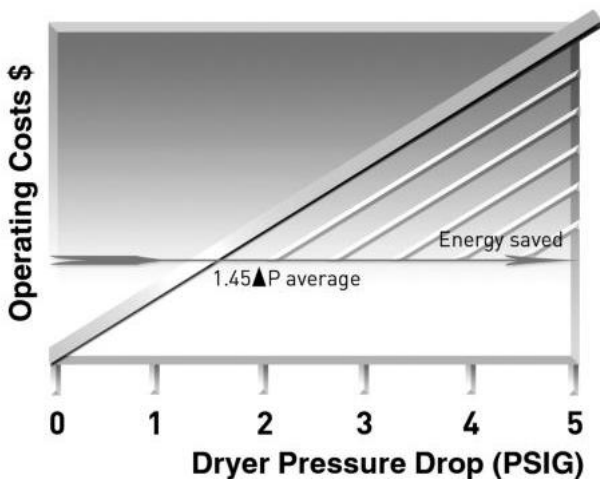

Poorly constructed heat exchangers and liquid separators create a high pressure differential across the dryer which leads to high operational costs and poor dewpoint performance.

The PRD dryer range utilizes advanced heat exchanger and demister separation technology and delivers uncompromising performance at the lowest cost of ownership.

Moisture separation technology

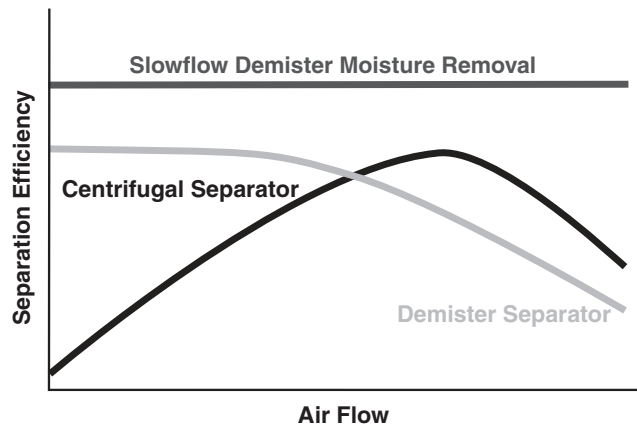

The oversized “slowflow” demister is non-velocity sensitive and therefore offers excellent liquid separation whatever the airflow.

Refrigeration
Disposable
Desiccant
Regenerative Desiccant
Heatless Desiccant
Dryers
M



For inventory, lead time, and kit lookup, visit www.pdnplu.com

Refrigeration Dryers

The importance of compressed air as a provider of energy for modern industrial processes is widely known. What is often overlooked however is the need to provide quality treatment for this air.

In fact, the air entering the system contains condensate which, when cooled, will turn into liquid water, causing extensive damage not only to the compressed air network, but also to the finished product.

PRD refrigeration dryers actively remove this condensate to achieve extremely dry compressed air.

Our SmartPack heat exchanger offers minimal pressure drops and class leading performance, and significantly increases the efficiency of the whole compressed air treatment process. The innovative SmartControl function automatically and continuously adjusts dryer operation to the effective working conditions, minimizing operating costs and maximizing performances.

Compressed air purification equipment must deliver uncompromising performance and reliability while providing the right balance of air quality with the lowest cost of operation. Many manufacturers offer products for the filtration and purification of contaminated compressed air, which are often selected only upon their initial purchase cost, with little or no regard for the air quality they provide, the cost of operation throughout their life or their environmental impact. When purchasing purification equipment, delivered air quality, the overall cost of ownership and the equipment's environmental impact must always be considered.

Smart technology: the benefits

SmartPack heat exchanger provides less than 2 PSI pressure drop

The SmartPack (patent pending) heat exchanger features an extremely robust, all-in-one aluminum design, with no interconnecting tubing.

The geometry of the heat exchanger has been designed in order to optimize its performances. In particular, large volumes allow low air velocity through the heat exchanger section, resulting in high exchange efficiency and low pressure drops. Pressure drops are further improved thanks to the absence of interconnecting pipes through the different sections of the heat exchanger and to a straight forward path of the compressed air flow with smooth and minimum changes of flow directions.

Smart BMS interface

- Simple BMS interface includes:
- RS485 serial card provides direct communication to Modbus. Requires no gateway or A.N.I.
- Provides visualization of dewpoint, alarm conditions and service indication
- Provides remote control of the dryer including on/off and alarm reset (depending on actual alarm)

Air Preparation Products Dryers



SmartDrain - Dual mode zero air loss drain

The drainage chamber is integrated into the heat exchanger while the valve mechanism is fitted in an easily accessible drain niche. The SmartDrain continuously adjusts itself to the actual working conditions, ensuring zero air loss and a notable reduction in system power consumption.

An innovative control system continuously monitors for fault situations. If a fault does occur, an alarm is signaled and the drain switches to conventional timed solenoid drain operation. The dual mode circuitry ensures maximum reliability.

Smart control with SmartSave cycling

The multifunction SmartControl provides a versatile platform for user interface and SmartSave Cycling (if enabled). The innovative SmartSave (patent pending)

Cycling Control continuously monitors the demand placed on the dryer. At conditions of low demand the refrigerant compressor is cycled off to save energy. A sophisticated algorithm continuously adapts the operation of the dryer for optimum energy efficiency while minimizing the dewpoint spikes common to traditional thermal mass dryers.

Compliant scroll compressors

These units feature Compliant Scroll compressors, offering energy savings of 20 -30% when compared with piston compressors. The ability to tolerate liquid returns coupled with 50% less moving parts render them nearly indestructible and highly reliable. Low vibration levels increase overall refrigeration circuit

Refrigeration

Disposable

Desiccant

Regenerative
DesiccantHeatless
Desiccant

Dryers

M



For inventory, lead times, and kit lookup, visit www.pdnplu.com

Operating information

		PRD10-PRD175	PRD200-PRD250	PRD325-PRD2400
Temperature:	Ambient (maximum)	122°F (50°C)	122°F (50°C)	122°F (50°C)
	Ambient (minimum)	41°F (5°C)	41°F (5°C)	41°F (5°C)
	Inlet (maximum)	149°F (65°C)	140°F (60°C)	140°F (60°C)
Pressure (maximum):		232 psig (16 bar)	203 psig (14 bar)	203 psig (14 bar)
Refrigerant:		R134a	R407C	R407C

Flow correction factors Capacities are based upon:
 Ambient temperature - 100°F (38°C); inlet temperature - 100°F (38°C);
 and working pressure - 100 psig (7 bar g).

To obtain dryer capacity at new conditions: nominal capacity x C1 x C2 x C3.
 Nominal capacity = pre-selected dryer model rated flow for application.

PRD10 - PRD175								PRD200 - PRD250								PRD325 - PRD2400							
Ambient temperature (C1)																							
°F	60	70	80	89	100	110	120	70	80	90	100	110	120	122	90	100	110	120	122				
°C	16	21	27	32	38	43	49	21	27	32	38	43	49	50	32	38	43	49	50				
Factor	1.34	1.26	1.17	1.09	1.00	0.91	0.82	1.22	1.12	1.08	1.00	0.9	0.79	0.71	1.05	1.00	0.94	0.79	0.71				
Inlet temperature (C2)																							
°F	90	100	110	120	140	149	90	100	110	120	130	140	90	100	110	120	130	140					
°C	32	38	43	49	60	65	32	38	43	49	54	60	32	38	43	49	54	60					
Factor	1.24	1.00	0.81	0.67	0.45	0.44	1.24	1.00	0.82	0.68	0.56	0.40	1.22	1.00	0.82	0.68	0.56	0.46					
Inlet pressure (C3)																							
psig	60	80	100	125	150	175	200	230	50	80	100	125	150	174	203	50	80	100	125	150	174	203	
bar	4	6	7	9	10	12	14	16	3	6	7	9	10	12	14	3	6	7	9	10	12	14	
Factor	0.83	0.93	1.00	1.07	1.12	1.16	1.19	1.22	0.77	0.93	1.00	1.07	1.12	1.15	1.18	0.77	0.93	1.00	1.07	1.12	1.15	1.18	

Dimensions

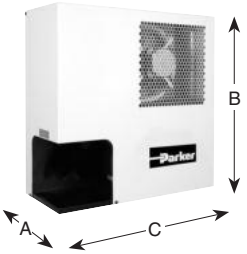
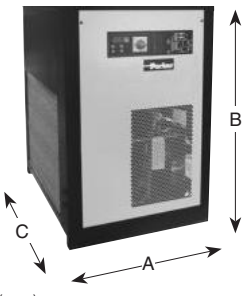
	Part number	A	B	C	Weight (kg)
	PRD10-115160	8.3 (210)	17 (430)	17.7 (450)	42 (19)
	PRD15-115160	8.3 (210)	17 (430)	17.7 (450)	42 (19)
	PRD25-115160	8.3 (210)	19.9 (505)	19.7 (500)	52 (24)
	PRD35-115160	8.3 (210)	19.9 (505)	19.7 (500)	52 (24)
	PRD50-115160	8.9 (225)	22.3 (565)	20.5 (520)	58 (27)
	PRD75-115160	8.9 (225)	22.3 (565)	20.5 (520)	68 (31)
	PRD100-115160	8.9 (225)	22.3 (565)	20.5 (520)	77 (35)
	PRD125-115160	16.7 (425)	23.8 (605)	21.8 (555)	115 (52)
	PRD150-115160	16.7 (425)	23.8 (605)	21.8 (555)	128 (58)
	PRD175-230160	16.7 (425)	23.8 (605)	21.8 (555)	132 (60)
	PRD200-230160	28.0 (711)	37.0 (940)	22.0 (559)	183 (83)
	PRD250-230360	28.0 (711)	42.0 (1067)	41.0 (1041)	287 (130)
	PRD325-230360	28.0 (711)	42.0 (1067)	41.0 (1041)	320 (145)
	PRD400-230360	28.0 (711)	42.0 (1067)	41.0 (1041)	320 (145)
	PRD500-230360	28.0 (711)	42.0 (1067)	41.0 (1041)	342 (155)
	PRD700-230360	32.0 (813)	52.0 (1321)	46.0 (1168)	529 (240)
	PRD800-230360	32.0 (813)	52.0 (1321)	46.0 (1168)	529 (240)
	PRD1000-460360	32.0 (813)	52.0 (1321)	46.0 (1168)	551 (250)
	PRD1200-460360	40.0 (1016)	67.0 (1702)	43.0 (1092)	816 (370)
	PRD1600-460360	40.0 (1016)	68.0 (1727)	71.0 (1803)	1279 (580)
PRD2000-460360	40.0 (1016)	68.0 (1727)	71.0 (1803)	1477 (670)	
PRD2400-460360	40.0 (1016)	68.0 (1727)	71.0 (1803)	1521 (690)	

Inches (mm)

Most popular.



For inventory, lead time, and kit lookup, visit www.pdnplu.com

Refrigeration

Disposable

Desiccant

Regenerative Desiccant

Heatless Desiccant

Dryers

M

DD10 Mini Disposable Dryer

Mini disposable inline desiccant dryer – DD10

Used at the point-of-use, this disposable, mini inline desiccant dryer removes all traces of water vapor, oil vapor and dirt. It is often used directly upstream of blow guns or spray guns as final protection for critical parts blow off and paint spraying. Install in either direction; it functions in both directions.

A 40 micron, porous bronze element removes fine dirt particles, an oil removing media removes oil vapor, and desiccant beads adsorb water vapor. The see-through housing shows desiccant color change from the original orange to a green color in the desiccant beads, which indicates that the dryer needs to be replaced.

Features

- Polycarbonate material allows clear desiccant visibility
- Disposable
- Used for parts blow off
- Protection for paint guns
- Non-toxic desiccant standard
- 1/4" port (NPT)



DD10-02

Operating information

Operating temperature:	32°F to 130°F (0°C to 54°C)
Maximum	130°F (54°C)
Flow capacity:	15 scfm (7.1 dm ³ /s, ANR)
Pressure rating (max.):	125 psig (8.6 bar)
Weight:	2.8 oz (79.4 g)

Installation

The DD10 is equipped with a 1/4" NPT (F) and (M) ports and can be installed in either direction. When installing the filter/dryer hand tighten to a leak proof seal. Do not use any mechanical means to hold the filter/dryer and do not over torque the threads.

Operation

1. The unique feature of the filter/dryer design allows you to visually see when it is time to install a new DD10 by observing the color change from the original orange color to a complete green color in the desiccant beads.
2. Do not attempt to clean the filter/dryer as the use of solvents, ketones, etc., will adversely affect the plastic housing.
3. Keep the hose free of snags. Extra tension on the filter/dryer assembly could break the unit at the connecting ports. To clear stuck hoses, grasp hose below the filter/dryer.

Non-metallic material is highly resistant to chemicals. See through housing shows color change when dryer needs replacement.

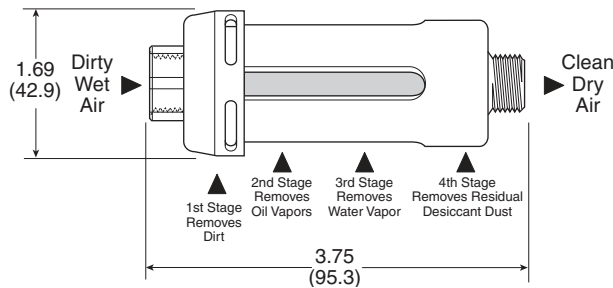

Refrigeration

Disposable

Desiccant

Regenerative Desiccant

Heatless Desiccant

Dryers

M

DD Inline Desiccant Dryers

- Inline desiccant dryers are a convenient and cost effective means of ensuring your sensitive intermittent pneumatic applications are never exposed to damaging moisture
- Compact size for point-of-use applications
- Drying efficiency down to -40°F pressure dew point
- Easily and quickly serviced
- Sight glass in bowl to monitor desiccant
- Built-in particulate after filter prevents downstream dust
- No electricity needed
- Low pressure drop
- No purge air lost as with other dryer types
- Check valve required on inlet
- Desiccant must be ordered separately



Inline Desiccant Dryers

Port size	Part number scfm / desiccant capacity ¹		
	15 scfm / 2.5 lb.	30 scfm / 5 lbs.	60 scfm / 10 lbs.
1/4 ²	DD15-02		
3/8 ²	DD15-03		
1/2 ²	DD15-04	DD30-04	DD60-04
3/4	DD15-06	DD30-06	DD60-06
1		DD30-08	DD60-08

Notes:

1. Desiccant must be ordered separately.
2. These units supplied with reducer bushings.

Installation tips

- Always place a moisture separator / particulate filter to remove bulk moisture and a coalescing filter to remove oil upstream of desiccant dryer. Desiccant coated with oil will not adsorb water vapor.
- Automatic drains should be used in prefilters
- A spring ball check valve should be installed at the dryer inlet to maximize the life of the desiccant.

Operating information

Optimum working temperature:	Below 100°F
Operating temperature:	32°F to 180°F (0°C to 82°C)
Operating pressure (max.):	0 to 300 psig (21 bar)
Filter element rating:	
DD15, DD30	90 micron
DD60	40 micron
Desiccant capacity:	
DD15	2.5 lb. (1.1 kg)
DD30	5 lb. (2.3 kg)
DD60	10 lb. (4.5 kg)
Weight:	
DD15 (add 2.5 lb for weight full)	8 lb. (3.6 kg)
DD30 (add 5 lb for weight full)	13 lb. (5.9 kg)
DD60 (add 10 lb for weight full)	20 lb. (9.1 kg)

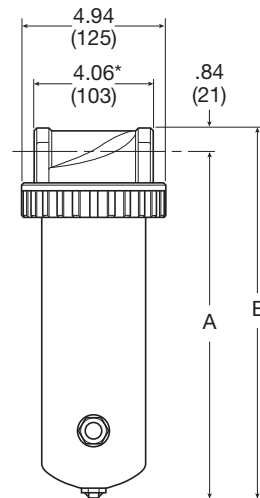

	A	B
DD15	12.69 (322)	13.5 (343)
DD30	22.44 (570)	23.25 (591)
DD60	29.44 (748)	30.25 (768)

* Dimension does not include reducer bushings for 1/4", 3/8", 1/2" versions.
 Inches (mm)

Most popular.



For inventory, lead time, and kit lookup, visit www.pdnplu.com

M7

Parker Hannifin Corporation
 Pneumatic Division
 Richland, Michigan
www.parker.com/pneumatics

Refrigeration

Disposable

Desiccant

Regenerative
Desiccant

Heatless
Desiccant

Dryers

M

As the wet compressed air enters through the inlet, the air travels down through the bed of desiccant which adsorb the water vapor and aerosols. The silica gel desiccant beads will reduce the humidity down to a -40°F pressure dew point. After the moisture has been removed, the dry air passes through a sintered bronze filter element (eliminating dust downstream), up the tube and out the outlet port.

As the desiccant becomes saturated with moisture, the dew point will begin to rise. This is evident when the orange silica gel desiccant beads in the sight glass change to green, indicating the need for desiccant replacement. Simply remove the flange and bowl and replace with new desiccant or regenerate saturated desiccant by heating to 275°F.

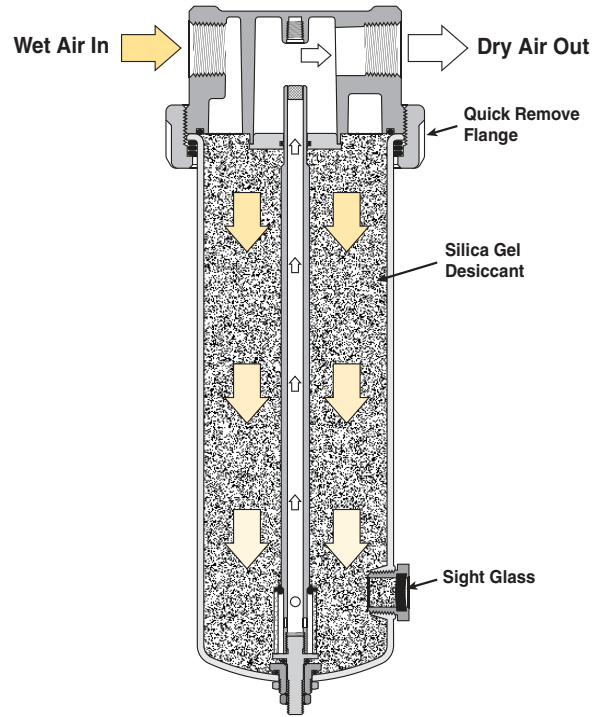

Material specifications

Bowl, DD15	Aluminum
Bowl, DD30	Aluminum
Bowl, DD60	Steel
Flow tube	CPVC
Filter element	Sintered bronze
Head & flange ring	Zinc
Other hardware	Brass
Seals	Buna-N
Sight glass	Glass & steel

Repair and Service Kits

Desiccant - 100% Indicating silica gel, DD15	DRP-14-447/003
Desiccant - 100% Indicating silica gel, DD30	DRP-14-447/006
Desiccant - 100% Indicating silica gel, DD60	DRP-14-447/012
Mounting brackets (pair of pipe mounted brackets), 1 inch pipe size	SA200CW57
Flow tube repair kit (tube, filter element(s), adaptor), DD15	RKDD15-02-06
Flow tube repair kit (tube, filter element(s), adaptor), DD30	RKDD30-03-08
Flow tube repair kit (tube, filter element(s), adaptor), DD60	RKDD60-03-08
Mounting brackets (DD15 & DD30 only) – 1 inch pipe size (pair of pipe mounted brackets)	SA200CW57
1/4 inch NPT, spring check valve for inlet (250 psig max.)	003393001
3/8 inch NPT, spring check valve for inlet (250 psig max.)	003393002
1/2 inch NPT, spring check valve for inlet (250 psig max.)	003393003
3/4 inch NPT, spring check valve for inlet (250 psig max.)	003393004

Refrigeration
Disposable
Desiccant
Regenerative Desiccant
Heatless Desiccant
Dryers
M



For inventory, lead times, and kit lookup, visit www.pdnplu.com

DAS Regenerative Desiccant Dryer

- Point of use application bringing clean dry air just where you need it
- Approved to international standards designed in accordance with ASME VIII Div.1, approved to CSA/UL/CRN and fully CE Marked (PED, EMC, LVD) as standard
- Simple to install - flexible installation utilizing the multiple in-line inlet & outlet connection ports
- Compact and lightweight - can be floor, bench or wall / canopy mounted
- Very quiet operation - noise level less than 70dB(A)
- Can be installed almost anywhere, IP66 / NEMA 4 protection as standard
- Audible alarm - indicating service interval for optimal performance
- Simple & easy to maintain - due to the quick release top cap arrangement, which does NOT require the inlet / outlet ports to be disconnected as with traditional systems, maintenance can be achieved in under 15 minutes

The DAS is the reliable, cost effective and flexible way to provide clean dry air exactly where needed.



Operating information

Operating temperature:	35°F to 131°F (1.5°C to 55°C)
Inlet temperature:	122°F (50°C) max.
Operating pressure:	58 to 175 psig (4 to 12 bar)
Flow range:	3 scfm to 20 scfm (@ 100 psig 85 L/min to 567 L/min @ 7 bar)
Noise level (Average):	70dB(A)
Pressure dewpoint – Standard	-40°F (-40°C) pdp (ISO 8573-1:2010 Class 2)
Standard electrical supply:	115/1ph/60Hz (Tolerance +/- 10%)
Controls:	Electronic control timer
Connections:	3/8 NPT

Regenerative Desiccant Dryer

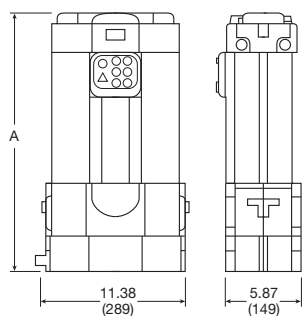

A	Weight (kg)	scfm	Part number	Maintenance kit *
16.6 (422)	24.2 (11)	3	DAS1-115-60-CSA	DASMK1
19.7 (500)	28.7 (13)	5	DAS2-115-60-CSA	DASMK2
24.2 (616)	35.3 (16)	8	DAS3-115-60-CSA	DASMK3
27.2 (692)	39.7 (18)	10	DAS4-115-60-CSA	DASMK4
33.3 (847)	44.1 (20)	13	DAS5-115-60-CSA	DASMK5
35.7 (906)	50.7 (23)	15	DAS6-115-60-CSA	DASMK6
43.2 (1098)	61.7 (28)	20	DAS7-115-60-CSA	DASMK7

* Kit includes: desiccant cartridge, MIDAS drain spanner, auto drain, 1/4" BSP silencer, AA prefilter, 3/4" balls, associated o-rings, push-in-plug.



Correction Factors

Capacities are based upon: Ambient temperature - 100°F (38°C); inlet temperature - 100°F (38°C); and working pressure - 100 psig (7 bar g)
 Minimum drying capacity = compressed air flow rate x CFT x CFP x CFD

Temperature Correction Factor (CFT)

Maximum inlet temperature	°F	77	86	95	104	113	122
	°C	25	30	35	40	45	50
CFT		1.00	1.00	1.00	1.04	1.14	1.37

Pressure Correction Factor (CFP)

Minimum inlet pressure	psi g	58	73	87	102	116	131	145	160	174
	bar g	4	5	6	7	8	9	10	11	12
CFP		1.60	1.33	1.14	1.00	1.03	0.93	0.85	0.78	0.71

Dewpoint Correction Factor (CFD) Standard

Required dewpoint	PDP °F	-40
	PDP °C	-40
CFD		1.00

Most popular.



For inventory, lead time, and kit lookup, visit www.pdnplu.com

Refrigeration
 Disposable
 Desiccant
 Regenerative Desiccant
 Heatless Desiccant
 Dryers



Product applications

Typical applications:

- Computer numerical control (CNC) machines
- Coordinate measuring machines
- Laboratories
- Lasers
- Packaging machines
- Instrumentation
- Processing equipment
- Conveying machines

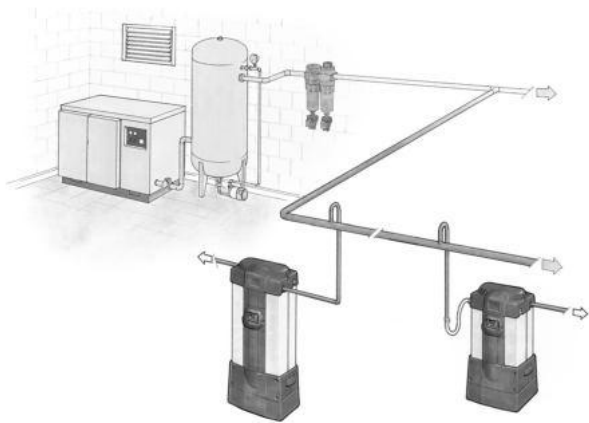

The Regenerative Desiccant Dryers will benefit users who have a specific need for Clean Dry Air (CDA) directly after a compressor, or for a particular application where the air is critical to the operating process or end product.

ISO7000 inlet & outlet symbols cast into the top cover ensure correct piping installation.

Electronic display providing high visibility LED indication with an internal audible alarm.

One Combo-Cartridge per column containing DRYFIL[®] MS desiccant and a 1µm particulate filter.

Integral 0.01µm high efficiency filter.

Positive removal of prefilter condensate by piping away for remote collection.

Easy access to electronic control box for mains connection.

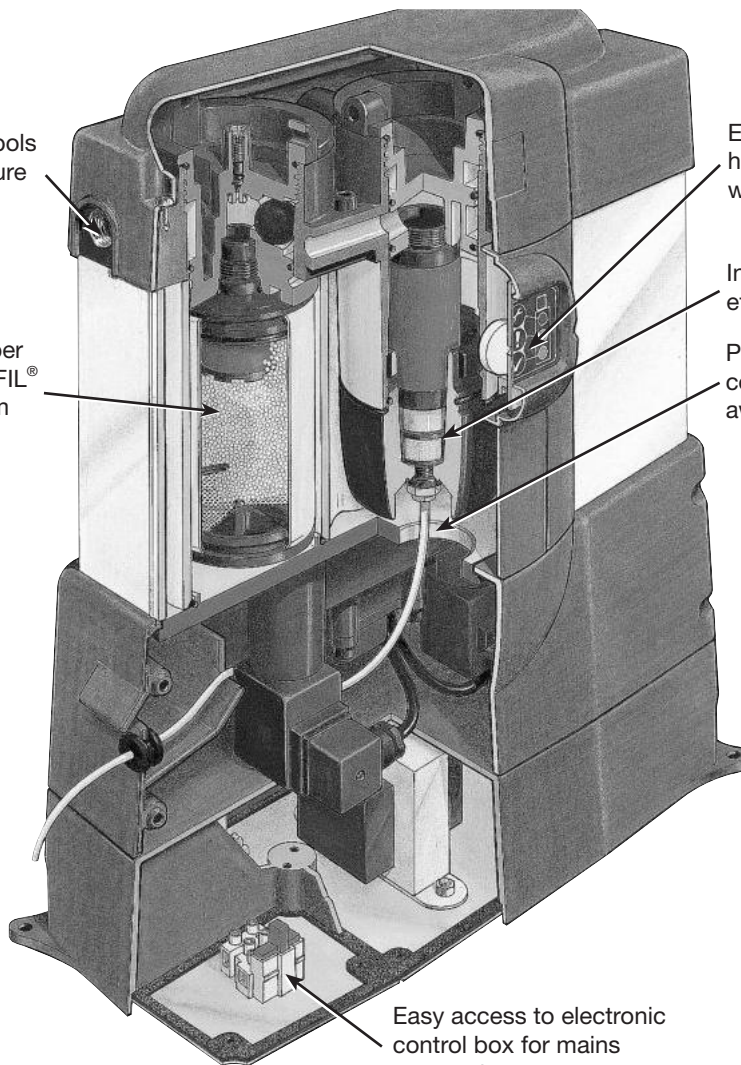

Refrigeration

Disposable

Desiccant

Regenerative Desiccant

Heateless Desiccant

Dryers

M

1 Compressed air enters the integral pre-filter and passes into the left hand chamber (Column A) where the air is dried before passing to the application.

A small amount of dry purge air is used to regenerate the right hand chamber (Column B) which is wet, using the PSA (Pressure Swing Adsorption) method of regeneration, venting the saturated air to atmosphere under pressure. The same regeneration air is also used to “back flush” the integral filter to prolong its working life.

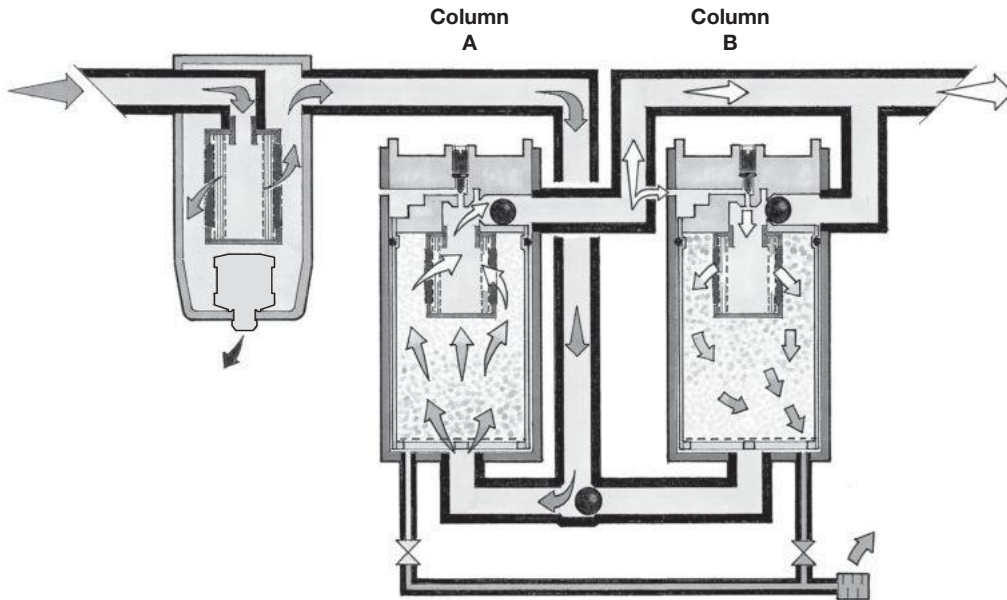

2 Prior to changeover, the right hand chamber (Column B) enters repressurization where the exhaust.

This process ensures a smooth uninterrupted changeover, preventing the loss of any system pressure, before the process repeats itself.

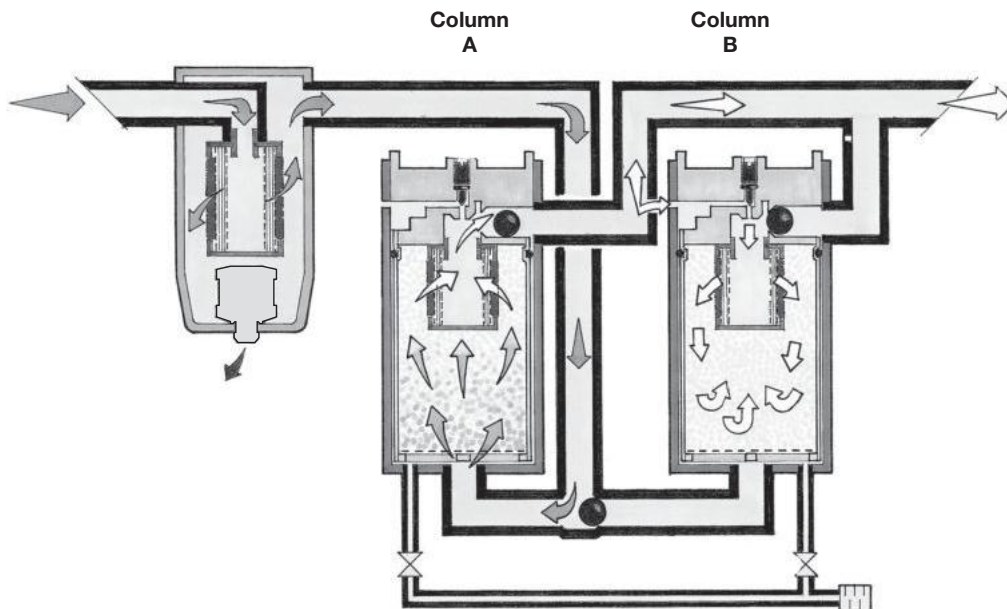

Refrigeration
Disposable
Desiccant
Regenerative Desiccant
Heatless Desiccant
Dryers
M

Regenerative Desiccant Dryers

Optional features

- For totally quiet operation, the regeneration exhaust air can be positively piped away.
- Remote indication provides a warning of the dryers need for servicing. (Audible alarm not included)
- Wall mounting kit for vertically securing the dryer to a wall or canopy.



- A 45° tilt, wall mounting kit is also available for vertically securing the dryer to a wall, canopy or inside a customers product where access to the top of the dryer is restricted.
- In conditions of limited access, the electronic control box (base) can be detached and relocated remotely from the dryer.

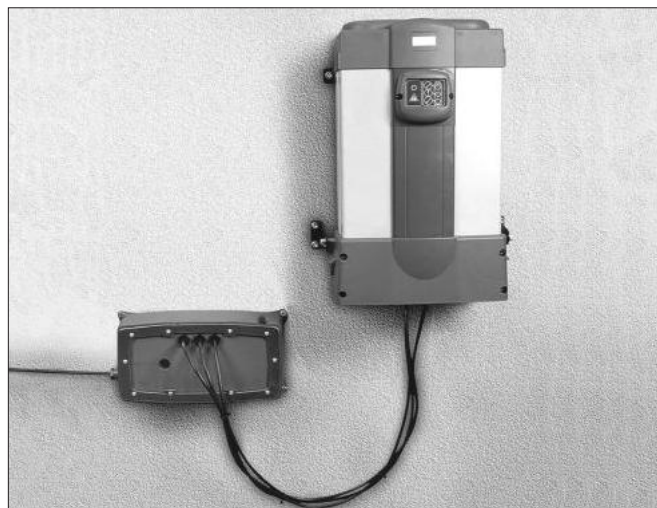

- Electronic control box can be remotely located.

Air Preparation Products Dryers

Service indication sequence & alarm

During operation, The Regenerative Desiccant Dryers Power On (yellow) LED and Check (Green) LED indicators will illuminate, remaining in this configuration for 11500 hours. At this time, the Warning (Yellow) LED will illuminate and cancel the Check (Green) LED. This signals the user to order service replacement components at the optimum time.

500 hours later (a total of 12000 hours from initial start up) the Service (Red) LED will illuminate and cancel the Warning (Yellow) LED, the Audible Alarm housed inside the display will sound intermittently (every 6 seconds) drawing attention to the need for a service.

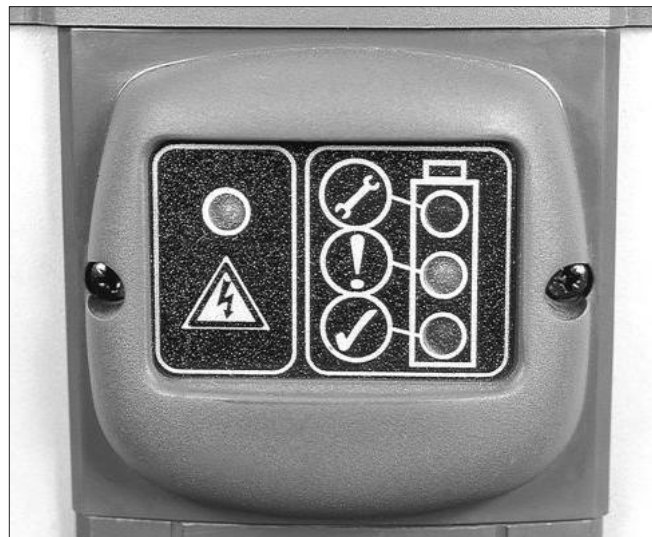

Refrigeration

Disposable

Desiccant

Regenerative
Desiccant

Heatless
Desiccant

Dryers

M

Heatless Desiccant Dryers

PTW Heatless Desiccant Air Dryer

Parker PTW Series Heatless Desiccant Air Dryers remove water vapor from compressed air through a process known as pressure swing adsorption. Pressure dewpoints ranging from -40°F (-40°C) standard to -100°F (-70°C) optional are attained by directing the flow of saturated compressed air over a bed of desiccant.

Features

- Pre-filter and after filters included with dryers
- Solid state controller
- CycleLoc™ demand control
- Variable cycle control (models PTW75 - PTW800 scfm)
- Purge Flow indicator
- Purge flow regulator (models PTW75 - PTW800 scfm)
- Repressurization circuit (models PTW75 - PTW800 scfm)
- Control air filter (models PTW75 - PTW800 scfm)
- Safety valves
- Pressure equalization
- 150 psig design standard
- Moisture indicator (models PTW75 - PTW800 scfm)

Options

- DDS Light / DDS (dewpoint dependent switching)

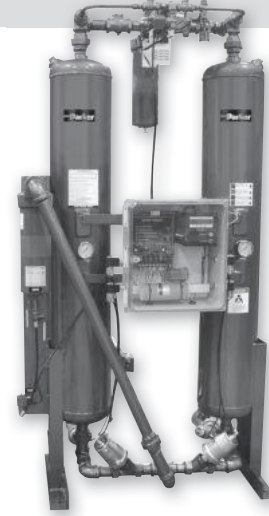

Operating information

Inlet or ambient air temperature:	50°F to 120°F (10°C to 49°C) maximum
Operating pressure:	80 psig (5.5 bar) minimum
Working pressure:	150 psig (10.5 bar) maximum
Pressure drop at rated flow:	less than 5 PSI (0.34 bar)

Heatless Desiccant Air Dryers

Part number	Capacity SCFM @ 100 psig (m³/min @ 6.9 bar)	Approximate purge scfm (Nm³/min)	Primary voltage	Port size (NPT)	Filtration package included with dryer		
					Pre-filter (5µ)	Pre-filter (.01µ)	After-filter (1µ)
PTW25*	25 (.70)	4 (.11)	120V/1ph/60Hz	1/2"	P32FB94ESAN	P32FB94DSAN	P32FB94QSAN
PTW40*	42 (1.19)	6 (.19)	120V/1ph/60Hz	1/2"	P33FA94ESAN	P33FA94DSAN	P33FA94QSAN
PTW55*	60 (1.70)	9 (.25)	120V/1ph/60Hz	3/4"	P33FA94ESAN	P33FA94DSAN	P33FA94QSAN
PTW75*	75 (2.13)	11 (.31)	120V/1ph/60Hz	3/4"	P3NFA96GSA †	P3NFA96DSA	P3NFA96GSA †
PTW100*	107 (3.03)	16 (.45)	120V/1ph/60Hz	1"	P3NFA98GSA †	P3NFA98DSA	P3NFA98GSA †
PTW130*	135 (3.82)	20 (.56)	120V/1ph/60Hz	1"	P3NFA98GSA †	P3NFA98DSA	P3NFA98GSA †
PTW200*	200 (5.66)	30 (.84)	120V/1ph/60Hz	1-1/2"	35F77BAP	35F77EAP	35F77HAP
PTW250*	250 (7.07)	38 (1.07)	120V/1ph/60Hz	1-1/2"	35F77BAP	35F77EAP	35F77HAP
PTW300*	300 (8.49)	45 (1.27)	120V/1ph/60Hz	1-1/2"	35F77BAP	35F77EAP	35F77HAP
PTW400*	400 (11.32)	60 (1.69)	120V/1ph/60Hz	2"	35F87BAP	35F87EAP	35F87HAP
PTW500*	500 (14.44)	77 (2.18)	120V/1ph/60Hz	2"	35F87BAP	35F87EAP	35F87HAP
PTW600*	600 (18.40)	98 (2.77)	120V/1ph/60Hz	2"	35F87BAP	35F87EAP	35F87HAP
PTW800*	800 (22.65)	120 (3.39)	120V/1ph/60Hz	2"	35F87BAP	35F87EAP	35F87HAP

* Options: Dewpoint dependent switching (DDS).

DDS Light includes: energy saving purge cycle control with high humidity alarm and indicator light. When ordering use -DL as suffix.

DDS includes: energy saving purge cycle control with high humidity alarm and digital dewpoint display. When ordering use -DS as suffix.

† 40 micron without DPI.

☐ Most popular.



For inventory, lead time, and kit lookup, visit www.pdnplu.com

M13

Parker Hannifin Corporation
Pneumatic Division
Richland, Michigan
www.parker.com/pneumatics

Refrigeration

Disposable

Desiccant

Regenerative Desiccant

Heatless Desiccant

Dryers

M

Heatless Desiccant Dryers

Parker PTW Series Heatless Desiccant Air Dryers remove water vapor from compressed air through a process known as Pressure Swing Adsorption. Pressure dewpoints ranging from -40°F (-40°C) standard to -100°F (-70°C) optional are attained by directing the flow of saturated compressed air over a bed of desiccant.

This physically tough and chemically inert material is contained in two separate but identical pressure vessels commonly referred to as “dual” or “twin” towers.

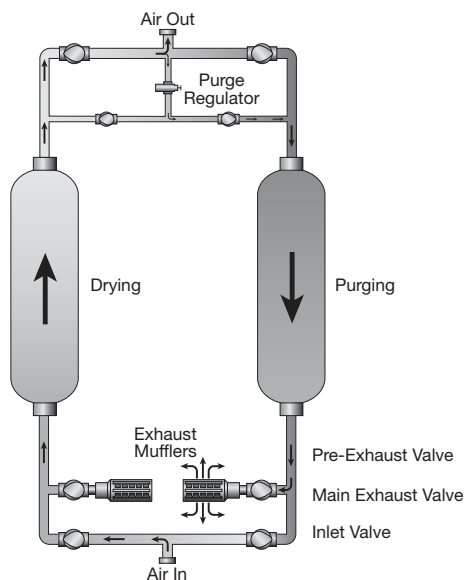

As the saturated compressed air flows up through the “on line” tower, its moisture content adheres to the surface of the desiccant. The dry compressed air is then discharged from the chamber into the distribution system.

A solid state controller automatically cycles the flow of compressed air between the towers, while the “on line” tower is drying, the “off line” tower is regenerating. Regeneration, sometimes referred to as purging, is the process by which moisture accumulated during the “on line” cycle is stripped away during the “off line” cycle. As low pressure dry purge air flows gently through the regenerating bed, it attracts the moisture that had accumulated on the surface of the desiccant during the drying cycle and exhausts it to the atmosphere.

To protect the desiccant bed from excess liquid, all Parker PTW Series Heatless Air Dryers are designed to work with the natural pull of gravity. By directing the saturated air into the bottom of the “on line” tower and flowing up through the bed, liquid condensate caused by system upset, is kept away from the desiccant and remains at the bottom of the tower where it can be easily exhausted during the regeneration cycle. Counter flow purging ensures optimum performance by keeping the driest desiccant at the discharge end of the dryer.

Moisture load, velocity, cycle time and contact time determine tower size and the amount of desiccant. To ensure design dewpoint, each tower is carefully sized to allow a minimum of 5.5 seconds of contact. To prevent desiccant dusting and bed fluidization, air flow velocities are kept below 50 feet per minute. The dryer can cycle for years without changing the desiccant.

Air Preparation Products Dryers

Heatless dryers in general are the most reliable and least expensive of all desiccant type dryers. Parker PTW Series Heatless Desiccant Air Dryers are the most energy efficient thanks to standard features like, “Variable Cycle control”, “CycleLoc™” and purge flow regulator.

Standard equipment

- Electric 120V/1PH/60Hz
- Solid state controller
- Centrifugal compressor surge protection (Models PTW75 - PTW800 scfm)
- System sequence annunciator
- CycleLoc™ demand control
- Variable cycle control (Models PTW75 - PTW800 scfm)
- Purge flow indicator
- Purge flow regulator (Models PTW75 - PTW800 scfm)
- Repressurization circuit (Models PTW75 - PTW800 scfm)
- ASME coded pressure vessels (Models PTW100 - PTW800 scfm)
- Separate tower pressure gauges
- Separate fill / drain ports
- NEMA 4 controls
- Stainless steel diffuser screen
- Pressure equalization
- 150 psig design standard
- Structural steel base
- Moisture indicator (PTW25 - PTW800 scfm)
- Pre and post filtration

Optional equipment

- Dewpoint Dependent Switching (DDS)
- 4-20 mA output
- All NEMA classifications
- Pressure to 1,000 psig (69 bar)
- High humidity alarm
- Fail to switch alarm
- Electronic drain systems
- -80°F to -100°F (-70°C to -62°C) dewpoints
- Contacts for remote alarms

Refrigeration

Disposable

Desiccant

Regenerative
Desiccant

Heatless
Desiccant

Dryers

M



For inventory, lead times, and kit lookup, visit www.pdnplu.com

Variable cycle control

Additional energy savings can be achieved by adjusting the amount of purge to the actual moisture load. When demand is expected to be less than maximum, Parker's Variable Cycle Control provides a means to adjust the purge cycle time to reduce the total amount of purge used for regeneration. As a result of less frequent cycling, the desiccant will last longer and the switching valves will require less maintenance. The Variable Cycle Control incorporates a short cycle position that can be employed to provide dewpoints as low as -80°F (-60°C).

Surge protection

To accommodate the unique requirements of centrifugal compressors, all Parker desiccant dryers are now programmed with a special anti-surge control. A sequenced timing circuit eliminates potential compressor surge by preventing momentary flow restrictions from occurring at tower switch over.

Total dryer operation is managed by a NEMA 4 automatic control center. The solid state module controls all dryer functions including the Sequence Annunciator.

Sequence annunciator

Parker's Sequence Annunciator is a solid state visual display panel that shows exactly what is happening in the dryer. The panel lights signal which tower is "on line" drying, and whether the "off line" tower is purging, repressurizing or in "CycleLoc™". It will also annunciate optional equipment operation and function alarms. The panel is integral with the NEMA 4 Master Control and is conveniently mounted for easy monitoring.

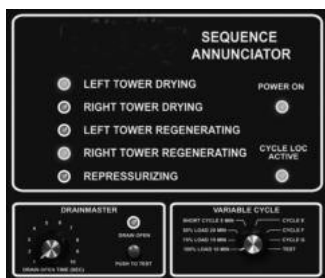

Dewpoint Dependent Switching (Optional)

Compressed air systems are rarely constant and the dryer regeneration cycle frequency is dependent upon the actual inlet flow, pressure and temperature. Operation under inlet conditions where there is lower than design flow and temperature and or higher pressure, will result in less regeneration cycles and a maximum in the cost of utilities.

Dewpoint Dependent Switching (DDS) provides a precision demand cycle control which terminates the adsorption (drying). This results in the full adsorptive capacity of the desiccant bed being utilized prior to switch over and regeneration.

DDS is built into the dryer control system, with a precision hygrometer producing a continuous display of the outlet dewpoint. The preset contacts of the instruments are utilized to initiate tower changeover.

Dewpoint Dependent Switching (DDS)

An Overview

The adsorption capacity of the desiccant within the dryer is essentially constant whereas the moisture loading and the air flow through the dryer are continuously varying as ambient and plant conditions change. In order to maintain the specified air quality downstream of the dryer, it has to be sized for the worst case conditions, namely the lowest pressure, highest flow and highest inlet temperature. These conditions may only occur for a small part of the service life of the dryer, for example, the highest inlet temperatures may only be present during the summer months. This means that the moisture loading on the desiccant beds is below the dryer's capacity for much of its service life (i.e. quiet periods in between shifts usually have lower air supply requirements). To gain access to this dynamic adsorption capacity, a moisture sensor is fitted which continually monitors the downstream dewpoint. DDS interrupts the normal sequence of the controller, which is only permitted to change over when the desiccant has adsorbed moisture to its capacity, effectively elongating the drying cycle. However, as regeneration has been optimized for a fully laden desiccant bed, this remains of constant duration resulting in a period of zero energy consumption (i.e. purging is discontinued). In this way, energy savings are obtained while maintaining a constant supply of clean dry air to your plant.



DDS



DDS Light

Refrigeration
Disposable
Desiccant
Regenerative Desiccant
Heatless Desiccant
Dryers
M

Flow correction factors

Capacities are based upon:

- Pressure drop at rated flow less than 5 psi (0.34 bar)
- Maximum inlet air or ambient air temperature 120°F (49°C)
- Maximum working pressure: 150 psig (10.5 bar g) standard units for high maximum working pressure are available
- Minimum operating pressure: 50 psig (3.5 bar g)

Correction Factors

To obtain drying capacity at new conditions: nominal capacity x CFT x CFP x CFD
Nominal capacity = pre-selected dryer model rated flow for application.

Temperature Correction Factor (CFT)

Maximum inlet temperature	°F	80	85	90	95	100	105	110	115	120
	°C	27	29	32	35	38	41	43	46	49
	CFT	1.17	1.17	1.17	1.15	1.00	0.87	0.76	0.66	0.58

Pressure Correction Factor (CFP)

Minimum inlet pressure	psi g	80	85	90	95	100	105	110	115	120	125	130	135
	bar g	5.51	5.86	6.21	6.55	6.89	7.24	7.58	7.93	8.27	8.62	8.96	9.31
	CFP	0.83	0.87	0.91	0.96	1.00	1.04	1.09	1.13	1.17	1.22	1.26	1.31

Dewpoint Correction Factor (CFD)

Required dewpoint	PDP °F	-40	-100
	PDP °C	-40	-70
	CFD	1.00	1.43

Heatless Desiccant Air Dryers

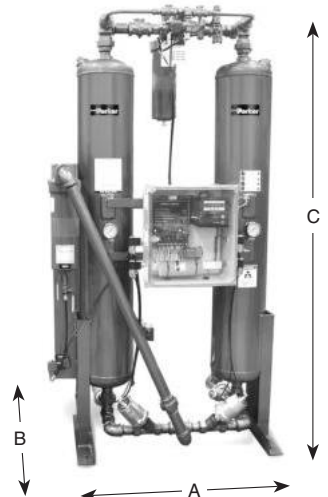
	Part number	A (length)	B (width)	C (height)	Weight lbs. (kg)
	PTW series				
	PTW25*	19 (483)	16 (406)	64 (1626)	156 (71)
	PTW40*	21 (533)	17 (432)	48 (1219)	190 (86)
	PTW55*	21 (533)	20 (508)	67 (1702)	230 (104)
	PTW75*	35 (889)	27 (686)	80 (2032)	384 (174)
	PTW100*	35 (889)	27 (686)	80 (2032)	468 (212)
	PTW130*	35 (899)	21 (533)	70 (1778)	496 (225)
	PTW200*	44 (1118)	28 (711)	78 (1981)	692 (314)
	PTW250*	44 (1118)	30 (762)	78 (1981)	776 (352)
	PTW300*	44 (1118)	30 (762)	78 (1981)	796 (361)
	PTW400*	74 (1880)	41 (1041)	84 (2134)	1626 (738)
	PTW500*	74 (1880)	41 (1041)	85 (2159)	1735 (787)
	PTW600*	74 (1880)	41 (1041)	86 (2184)	1740 (789)
PTW800*	74 (1880)	41 (1041)	91 (2311)	2120 (962)	

* Options: Dewpoint dependent switching (DDS).

DDS Light includes: energy saving purge cycle control with high humidity alarm and indicator light. When ordering use -DL as suffix.

DDS includes: energy saving purge cycle control with high humidity alarm and digital dewpoint display. When ordering use -DS as suffix.

Repair and Service Kits

Element kits

	5µ	0.01µ	1.0µ
P32	P32KA00ESE	P32KA00ESC	P32KA00ES9
P33	P33KA00ESE	P33KA00ESC	P33KA00ES9
P3NF	P3NKA00ESE	P3NKA00ESCB	P3KNA00ES9
35F	FRP-95-505	MTP-95-502	MSP-95-502

Most popular.



For inventory, lead times, and kit lookup, visit www.pdnplu.com

Safety Guide For Selecting And Using Pneumatic Division Products And Related Accessories

WARNING:

FAILURE OR IMPROPER SELECTION OR IMPROPER USE OF PNEUMATIC DIVISION PRODUCTS, ASSEMBLIES OR RELATED ITEMS ("PRODUCTS") CAN CAUSE DEATH, PERSONAL INJURY, AND PROPERTY DAMAGE. POSSIBLE CONSEQUENCES OF FAILURE OR IMPROPER SELECTION OR IMPROPER USE OF THESE PRODUCTS INCLUDE BUT ARE NOT LIMITED TO:

- Unintended or mistimed cycling or motion of machine members or failure to cycle
- Work pieces or component parts being thrown off at high speeds.
- Failure of a device to function properly for example, failure to clamp or unclamp an associated item or device.
- Explosion
- Suddenly moving or falling objects.
- Release of toxic or otherwise injurious liquids or gasses.

Before selecting or using any of these Products, it is important that you read and follow the instructions below.

1. GENERAL INSTRUCTIONS

- 1.1. Scope:** This safety guide is designed to cover general guidelines on the installation, use, and maintenance of Pneumatic Division Valves, FRLs (Filters, Pressure Regulators, and Lubricators), Vacuum products and related accessory components.
- 1.2. Fail-Safe:** Valves, FRLs, Vacuum products and their related components can and do fail without warning for many reasons. Design all systems and equipment in a fail-safe mode, so that failure of associated valves, FRLs or Vacuum products will not endanger persons or property.
- 1.3 Relevant International Standards:** For a good guide to the application of a broad spectrum of pneumatic fluid power devices see: ISO 4414:1998, Pneumatic Fluid Power – General Rules Relating to Systems. See www.iso.org for ordering information.
- 1.4. Distribution:** Provide a copy of this safety guide to each person that is responsible for selection, installation, or use of Valves, FRLs or Vacuum products. Do not select, or use Parker valves, FRLs or vacuum products without thoroughly reading and understanding this safety guide as well as the specific Parker publications for the products considered or selected.
- 1.5. User Responsibility:** Due to the wide variety of operating conditions and applications for valves, FRLs, and vacuum products Parker and its distributors do not represent or warrant that any particular valve, FRL or vacuum product is suitable for any specific end use system. This safety guide does not analyze all technical parameters that must be considered in selecting a product. The user, through its own analysis and testing, is solely responsible for:
 - Making the final selection of the appropriate valve, FRL, Vacuum component, or accessory.
 - Assuring that all user's performance, endurance, maintenance, safety, and warning requirements are met and that the application presents no health or safety hazards.
 - Complying with all existing warning labels and / or providing all appropriate health and safety warnings on the equipment on which the valves, FRLs or Vacuum products are used; and,
 - Assuring compliance with all applicable government and industry standards.
- 1.6. Safety Devices:** Safety devices should not be removed, or defeated.
- 1.7. Warning Labels:** Warning labels should not be removed, painted over or otherwise obscured.
- 1.8. Additional Questions:** Call the appropriate Parker technical service department if you have any questions or require any additional information. See the Parker publication for the product being considered or used, or call 1-800-CPARKER, or go to www.parker.com, for telephone numbers of the appropriate technical service department.

2. PRODUCT SELECTION INSTRUCTIONS

- 2.1. Flow Rate:** The flow rate requirements of a system are frequently the primary consideration when designing any pneumatic system. System components need to be able to provide adequate flow and pressure for the desired application.
- 2.2. Pressure Rating:** Never exceed the rated pressure of a product. Consult product labeling, Pneumatic Division catalogs or the instruction sheets supplied for maximum pressure ratings.
- 2.3. Temperature Rating:** Never exceed the temperature rating of a product. Excessive heat can shorten the life expectancy of a product and result in complete product failure.
- 2.4. Environment:** Many environmental conditions can affect the integrity and suitability of a product for a given application. Pneumatic Division products are designed for use in general purpose industrial applications. If these products are to be used in unusual circumstances such as direct sunlight and/or corrosive or caustic environments, such use can shorten the useful life and lead to premature failure of a product.
- 2.5. Lubrication and Compressor Carryover:** Some modern synthetic oils can and will attack nitrile seals. If there is any possibility of synthetic oils or greases migrating into the pneumatic components check for compatibility with the seal materials used. Consult the factory or product literature for materials of construction.
- 2.6. Polycarbonate Bowls and Sight Glasses:** To avoid potential polycarbonate bowl failures:
 - Do not locate polycarbonate bowls or sight glasses in areas where they could be subject to direct sunlight, impact blow, or temperatures outside of the rated range.
 - Do not expose or clean polycarbonate bowls with detergents, chlorinated hydro-carbons, ketones, esters or certain alcohols.
 - Do not use polycarbonate bowls or sight glasses in air systems where compressors are lubricated with fire resistant fluids such as phosphate ester and di-ester lubricants.



2.7. Chemical Compatibility: For more information on plastic component chemical compatibility see Pneumatic Division technical bulletins Tec-3, Tec-4, and Tec-5

- 2.8. Product Rupture:** Product rupture can cause death, serious personal injury, and property damage.
- Do not connect pressure regulators or other Pneumatic Division products to bottled gas cylinders.
 - Do not exceed the maximum primary pressure rating of any pressure regulator or any system component.
 - Consult product labeling or product literature for pressure rating limitations.

3. PRODUCT ASSEMBLY AND INSTALLATION INSTRUCTIONS

- 3.1. Component Inspection:** Prior to assembly or installation a careful examination of the valves, FRLs or vacuum products must be performed. All components must be checked for correct style, size, and catalog number. DO NOT use any component that displays any signs of nonconformance.
- 3.2. Installation Instructions:** Parker published Installation Instructions must be followed for installation of Parker valves, FRLs and vacuum components. These instructions are provided with every Parker valve or FRL sold, or by calling 1-800-CPARKER, or at www.parker.com.
- 3.3. Air Supply:** The air supply or control medium supplied to Valves, FRLs and Vacuum components must be moisture-free if ambient temperature can drop below freezing

4. VALVE AND FRL MAINTENANCE AND REPLACEMENT INSTRUCTIONS

- 4.1. Maintenance:** Even with proper selection and installation, valve, FRL and vacuum products service life may be significantly reduced without a continuing maintenance program. The severity of the application, risk potential from a component failure, and experience with any known failures in the application or in similar applications should determine the frequency of inspections and the servicing or replacement of Pneumatic Division products so that products are replaced before any failure occurs. A maintenance program must be established and followed by the user and, at minimum, must include instructions 4.2 through 4.9.
- 4.2. Installation and Service Instructions:** Before attempting to service or replace any worn or damaged parts consult the appropriate Service Bulletin for the valve or FRL in question for the appropriate practices to service the unit in question. These Service and Installation Instructions are provided with every Parker valve and FRL sold, or are available by calling 1-800-CPARKER, or by accessing the Parker web site at www.parker.com.
- 4.3. Lockout / Tagout Procedures:** Be sure to follow all required lockout and tagout procedures when servicing equipment. For more information see: OSHA Standard – 29 CFR, Part 1910.147, Appendix A, The Control of Hazardous Energy – (Lockout / Tagout)
- 4.4. Visual Inspection:** Any of the following conditions requires immediate system shut down and replacement of worn or damaged components:
- Air leakage: Look and listen to see if there are any signs of visual damage to any of the components in the system. Leakage is an indication of worn or damaged components.
 - Damaged or degraded components: Look to see if there are any visible signs of wear or component degradation.
 - Kinked, crushed, or damaged hoses. Kinked hoses can result in restricted air flow and lead to unpredictable system behavior.
 - Any observed improper system or component function: Immediately shut down the system and correct malfunction.
 - Excessive dirt build-up: Dirt and clutter can mask potentially hazardous situations.

Caution: Leak detection solutions should be rinsed off after use.

- 4.5. Routine Maintenance Issues:**
- Remove excessive dirt, grime and clutter from work areas.
 - Make sure all required guards and shields are in place.
- 4.6. Functional Test:** Before initiating automatic operation, operate the system manually to make sure all required functions operate properly and safely.
- 4.7. Service or Replacement Intervals:** It is the user’s responsibility to establish appropriate service intervals. Valves, FRLs and vacuum products contain components that age, harden, wear, and otherwise deteriorate over time. Environmental conditions can significantly accelerate this process. Valves, FRLs and vacuum components need to be serviced or replaced on routine intervals. Service intervals need to be established based on:
- Previous performance experiences.
 - Government and / or industrial standards.
 - When failures could result in unacceptable down time, equipment damage or personal injury risk.
- 4.8. Servicing or Replacing of any Worn or Damaged Parts:** To avoid unpredictable system behavior that can cause death, personal injury and property damage:
- Follow all government, state and local safety and servicing practices prior to service including but not limited to all OSHA Lockout Tagout procedures (OSHA Standard – 29 CFR, Part 1910.147, Appendix A, The Control of Hazardous Energy – Lockout / Tagout).
 - Disconnect electrical supply (when necessary) before installation, servicing, or conversion.
 - Disconnect air supply and depressurize all air lines connected to system and Pneumatic Division products before installation, service, or conversion.
 - Installation, servicing, and / or conversion of these products must be performed by knowledgeable personnel who understand how pneumatic products are to be applied.
 - After installation, servicing, or conversions air and electrical supplies (when necessary) should be connected and the product tested for proper function and leakage. If audible leakage is present, or if the product does not operate properly, do not put product or system into use.
 - Warnings and specifications on the product should not be covered or painted over. If masking is not possible, contact your local representative for replacement labels.

4.9. Putting Serviced System Back into Operation: Follow the guidelines above and all relevant Installation and Maintenance Instructions supplied with the valve FRL or vacuum component to insure proper function of the system.

Part Number
Index

Safety Guide

Offer of Sale

Part Number Index,
Safety Guide, Offer of Sale



For inventory, lead time, and kit lookup, visit www.pdnplu.com

PARKER-HANNIFIN CORPORATION
OFFER OF SALE

1. **Definitions.** As used herein, the following terms have the meanings indicated.

Buyer:	means any customer receiving a Quote for Products from Seller.
Goods:	means any tangible part, system or component to be supplied by the Seller.
Products:	means the Goods, Services and/or Software as described in a Quote provided by the Seller.
Quote:	means the offer or proposal made by Seller to Buyer for the supply of Products.
Seller:	means Parker-Hannifin Corporation, including all divisions and businesses thereof.
Services:	means any services to be supplied by the Seller.
Software:	means any software related to the Products, whether embedded or separately downloaded.
Terms:	means the terms and conditions of this Offer of Sale or any newer version of the same as published by Seller electronically at www.parker.com/saleterms .

2. **Terms.** All sales of Products by Seller are contingent upon, and will be governed by, these Terms and, these Terms are incorporated into any Quote provided by Seller to any Buyer. Buyer's order for any Products whether communicated to Seller verbally, in writing, by electronic data interface or other electronic commerce, shall constitute acceptance of these Terms. Seller objects to any contrary or additional terms or conditions of Buyer. Reference in Seller's order acknowledgement to Buyer's purchase order or purchase order number shall in no way constitute an acceptance of any of Buyer's terms of purchase. No modification to these Terms will be binding on Seller unless agreed to in writing and signed by an authorized representative of Seller.

3. **Price; Payment.** The Products set forth in Seller's Quote are offered for sale at the prices indicated in Seller's Quote. Unless otherwise specifically stated in Seller's Quote, prices are valid for thirty (30) days and do not include any sales, use, or other taxes or duties. Seller reserves the right to modify prices at any time to adjust for any raw material price fluctuations. Unless otherwise specified by Seller, all prices are F.C.A. Seller's facility (INCOTERMS 2010). All sales are contingent upon credit approval and payment for all purchases is due thirty (30) days from the date of invoice (or such date as may be specified in the Quote). Unpaid invoices beyond the specified payment date incur interest at the rate of 1.5% per month or the maximum allowable rate under applicable law.

4. **Shipment; Delivery; Title and Risk of Loss.** All delivery dates are approximate. Seller is not responsible for damages resulting from any delay. Regardless of the manner of shipment, delivery occurs and title and risk of loss or damage pass to Buyer, upon placement of the Products with the shipment carrier at Seller's facility. Unless otherwise agreed, Seller may exercise its judgment in choosing the carrier and means of delivery. No deferment of shipment at Buyer's request beyond the respective indicated shipping date will be made except on terms that will indemnify, defend and hold Seller harmless against all loss and additional expense. Buyer shall be responsible for any additional shipping charges incurred by Seller due to Buyer's acts or omissions.

5. **Warranty.** The warranty related to the Products is as follows: (i) Goods are warranted against defects in material or workmanship for a period of twelve (12) months from the date of delivery or 2,000 hours of use, whichever occurs first; (ii) Services shall be performed in accordance with generally accepted practices and using the degree of care and skill that is ordinarily exercised and customary in the field to which the Services pertain and are warranted for a period of six (6) months from the completion of the Services by Seller; and (iii) Software is only warranted to perform in accordance with applicable specifications provided by Seller to Buyer for ninety (90) days from the date of delivery or, when downloaded by a Buyer or end-user, from the date of the initial download. All prices are based upon the exclusive limited warranty stated above, and upon the following disclaimer:

DISCLAIMER OF WARRANTY: THIS WARRANTY IS THE SOLE AND ENTIRE WARRANTY PERTAINING TO PRODUCTS. SELLER DISCLAIMS ALL OTHER WARRANTIES, EXPRESS AND IMPLIED, INCLUDING DESIGN, NONINFRINGEMENT, MERCHANTABILITY, AND FITNESS FOR A PARTICULAR PURPOSE. SELLER DOES NOT WARRANT THAT THE SOFTWARE IS ERROR-FREE OR FAULT-TOLERANT, OR THAT BUYER'S USE THEREOF WILL BE SECURE OR UNINTERRUPTED. BUYER AGREES AND ACKNOWLEDGES THAT UNLESS OTHERWISE AUTHORIZED IN WRITING BY SELLER THE SOFTWARE SHALL NOT BE USED IN CONNECTION WITH HAZARDOUS OR HIGH RISK ACTIVITIES OR ENVIRONMENTS. EXCEPT AS EXPRESSLY STATED HEREIN, ALL PRODUCTS ARE PROVIDED "AS IS".

6. **Claims; Commencement of Actions.** Buyer shall promptly inspect all Products upon receipt. No claims for shortages will be allowed unless reported to the Seller within ten (10) days of delivery. Buyer shall notify Seller of any alleged breach of warranty within thirty (30) days after the date the non-conformance is or should have been discovered by Buyer. Any claim or action against Seller based upon breach of contract or any other theory, including tort, negligence, or otherwise must be commenced within twelve (12) months from the date of the alleged breach or other alleged event, without regard to the date of discovery.

7. **LIMITATION OF LIABILITY.** IN THE EVENT OF A BREACH OF WARRANTY, SELLER WILL, AT ITS OPTION, REPAIR OR REPLACE THE NON-CONFORMING PRODUCT, RE-PERFORM THE SERVICES, OR REFUND THE PURCHASE PRICE PAID WITHIN A REASONABLE PERIOD OF TIME. IN NO EVENT IS SELLER LIABLE FOR ANY SPECIAL, INDIRECT, INCIDENTAL OR CONSEQUENTIAL DAMAGES ARISING OUT OF, OR AS THE RESULT OF, THE SALE, DELIVERY, NON-DELIVERY, SERVICING, NON-COMPLETION OF SERVICES, USE, LOSS OF USE OF, OR INABILITY TO USE THE PRODUCTS OR ANY PART THEREOF, LOSS OF DATA, IDENTITY, PRIVACY, OR CONFIDENTIALITY, OR FOR ANY CHARGES OR EXPENSES OF ANY NATURE INCURRED WITHOUT SELLER'S WRITTEN CONSENT, WHETHER BASED IN CONTRACT, TORT OR OTHER LEGAL THEORY. IN NO EVENT SHALL SELLER'S LIABILITY UNDER ANY CLAIM MADE BY BUYER EXCEED THE PURCHASE PRICE PAID FOR THE PRODUCTS.

8. **Loss to Buyer's Property.** Any designs, tools, patterns, materials, drawings, confidential information or equipment furnished by Buyer or any other items which are or become Buyer's property, will be considered obsolete and may be destroyed by Seller after two (2) consecutive years have elapsed without Buyer ordering the Products manufactured using such property. Seller shall not be responsible for any loss or damage to such property while it is in Seller's possession or control.

9. **Special Tooling.** Special Tooling includes but is not limited to tooling, jigs, fixtures and associated manufacturing equipment acquired or necessary to manufacture Products. A tooling charge may be imposed for any Special Tooling. Such Special Tooling shall be and remain Seller's property notwithstanding payment of any charges by Buyer. In no event will Buyer acquire any interest in Special Tooling belonging to Seller that is utilized in the manufacture of the Products, even if such Special Tooling has been specially converted or adapted for such manufacture and notwithstanding any charges paid by Buyer. Unless otherwise agreed, Seller has the right to alter, discard or otherwise dispose of any Special Tooling or other property in its sole discretion at any time.

10. **Security Interest.** To secure payment of all sums due, Seller retains a security interest in all Products delivered to Buyer and, Buyer's acceptance of these Terms is deemed to be a Security Agreement under the Uniform Commercial Code. Buyer authorizes Seller as its attorney to execute and file on Buyer's behalf all documents Seller deems necessary to perfect its security interest.

11. **User Responsibility.** The Buyer through its own analysis and testing, is solely responsible for making the final selection of the Products and assuring that all performance, endurance, maintenance, safety and warning requirements of the application of the Products are met. The Buyer must analyze all aspects of the application and follow applicable industry standards, specifications, and other technical information provided with the Product. If Seller provides Product options based upon data or specifications provided by the Buyer, the Buyer is responsible for determining that such data and specifications are suitable and sufficient for all applications and reasonably foreseeable uses of the Products. In the event the Buyer is not the end-user, Buyer will ensure such end-user complies with this paragraph.

12. **Use of Products; Indemnity by Buyer.** Buyer shall comply with all instructions, guides and specifications provided by Seller with the Products. **Unauthorized Uses.** If Buyer uses or resells the Products for any uses prohibited in Seller's instructions, guides or specifications, or Buyer otherwise fails to comply with Seller's instructions, guides and specifications, Buyer acknowledges that any such use, resale, or non-compliance is at Buyer's sole risk. Buyer shall indemnify, defend, and hold Seller harmless from any losses, claims, liabilities, damages, lawsuits, judgments and costs (including attorney fees and defense costs), whether for personal injury, property damage, intellectual property infringement or any other claim, brought by or incurred by Buyer, Buyer's employees, or any other person, arising out of: (a) improper selection, application, design, specification or other misuse of Products provided by Seller; (b) any act or omission, negligent or otherwise, of Buyer; (c) Seller's use of patterns, tooling, equipment, plans, drawings, designs or specifications or other information or things furnished by Buyer; (d) damage to the Products from an external cause, repair or attempted repair by anyone other than Seller, failure to follow instructions, guides and specifications provided by Seller, use with goods not provided by Seller, or opening, modifying, deconstructing or tampering with the Products for any reason; or (e) Buyer's failure to comply with these Terms. Seller shall not indemnify Buyer under any circumstance except as otherwise provided in these Terms.

13. **Cancellations and Changes.** Buyer may not cancel or modify any order for any reason, except with Seller's written consent and upon terms that will indemnify, defend and hold Seller harmless against all direct, incidental and consequential loss or damage. Seller, at any time, may change Product features, specifications, designs and availability.

14. **Limitation on Assignment.** Buyer may not assign its rights or obligations without the prior written consent of Seller.

15. **Force Majeure.** Seller does not assume the risk and is not liable for delay or failure to perform any of Seller's obligations by reason of events or circumstances beyond its reasonable control ("Events of Force Majeure"). Events of Force Majeure shall include without limitation: accidents, strikes or labor disputes, acts of any government or government agency, acts of nature, delays or failures in delivery from carriers or suppliers, shortages of materials, or any other cause beyond Seller's reasonable control.

16. **Waiver and Severability.** Failure to enforce any provision of these Terms will not invalidate that provision; nor will any such failure prejudice Seller's right to enforce that provision in the future. Invalidation of any provision of these Terms by legislation or other rule of law shall not invalidate any other provision herein and, the remaining provisions will remain in full force and effect.

17. **Termination.** Seller may terminate any agreement governed by or arising from these Terms for any reason and at any time by giving Buyer thirty (30) days prior written notice. Seller may immediately terminate, in writing, if Buyer: (a) breaches any provision of these Terms (b) appoints a trustee, receiver or custodian for all or any part of Buyer's property (c) files a petition for relief in bankruptcy on its own behalf, or one filed by a third party (d) makes an assignment for the benefit of creditors; or (e) dissolves its business or liquidates all or a majority of its assets.

18. **Ownership of Software.** Seller retains ownership of all Software supplied to Buyer hereunder. In no event shall Buyer obtain any greater right in and to the Software than a right in the nature of a license limited to the use thereof and subject to compliance with any other terms provided with the Software.

19. **Indemnity for Infringement of Intellectual Property Rights.** Seller is not liable for infringement of any patents, trademarks, copyrights, trade dress, trade secrets or similar rights ("Intellectual Property Rights") except as provided in this Section. Seller will defend at its expense and will pay the cost of any settlement or damages awarded in an action brought against Buyer based on a third party claim that one or more of the Products sold hereunder infringes the Intellectual Property Rights of a third party in the country of delivery of the Products by the Seller to the Buyer. Seller's obligation to defend and indemnify Buyer is contingent on Buyer notifying Seller within ten (10) days after Buyer becomes aware of any such claim, and Seller having sole control over the defense of the claim including all negotiations for settlement or compromise. If one or more Products sold hereunder is subject to such a claim, Seller may, at its sole expense and option, procure for Buyer the right to continue using the Products, replace or modify the Products so as to render them non-infringing, or offer to accept return of the Products and refund the purchase price less a reasonable allowance for depreciation. Seller has no obligation or liability for any claim of infringement: (i) arising from information provided by Buyer; or (ii) directed to any Products provided hereunder for which the designs are specified in whole or part by Buyer; or (iii) resulting from the modification, combination or use in a system of any Products provided hereunder. The foregoing provisions of this Section constitute Seller's sole and exclusive liability and Buyer's sole and exclusive remedy for such claims of infringement of Intellectual Property Rights.

20. **Governing Law.** These Terms and the sale and delivery of all Products are deemed to have taken place in, and shall be governed and construed in accordance with, the laws of the State of Ohio, as applicable to contracts executed and wholly performed therein and without regard to conflicts of laws principles. Buyer irrevocably agrees and consents to the exclusive jurisdiction and venue of the courts of Cuyahoga County, Ohio with respect to any dispute, controversy or claim arising out of or relating to the sale and delivery of the Products.

21. **Entire Agreement.** These Terms, along with the terms set forth in the main body of any Quote, forms the entire agreement between the Buyer and Seller and constitutes the final, complete and exclusive expression of the terms of sale. In the event of a conflict between any term set forth in the main body of a Quote and these Terms, the terms set forth in the main body of the Quote shall prevail. All prior or contemporaneous written or oral agreements or negotiations with respect to the subject matter shall have no effect. These Terms may not be modified unless in writing and signed by an authorized representative of Seller.

22. **Compliance with Laws.** Buyer agrees to comply with all applicable laws, regulations, and industry and professional standards, including those of the United States of America, and the country or countries in which Buyer may operate, including without limitation the U.S. Foreign Corrupt Practices Act ("FCPA"), the U.S. Anti-Kickback Act ("Anti-Kickback Act"), U.S. and E.U. export control and sanctions laws ("Export Laws"), the U.S. Food Drug and Cosmetic Act ("FDCA"), and the rules and regulations promulgated by the U.S. Food and Drug Administration ("FDA"), each as currently amended. Buyer agrees to indemnify, defend, and hold harmless Seller from the consequences of any violation of such laws, regulations and standards by Buyer, its employees or agents. Buyer acknowledges that it is familiar with all applicable provisions of the FCPA, the Anti-Kickback Act, Export Laws, the FDCA and the FDA and certifies that Buyer will adhere to the requirements thereof and not take any action that would make Seller violate such requirements. Buyer represents and agrees that Buyer will not make any payment or give anything of value, directly or indirectly, to any governmental official, foreign political party or official thereof, candidate for foreign political office, or commercial entity or person, for any improper purpose, including the purpose of influencing such person to purchase Products or otherwise benefit the business of Seller. Buyer further represents and agrees that it will not receive, use, service, transfer or ship any Product from Seller in a manner or for a purpose that violates Export Laws or would cause Seller to be in violation of Export Laws.