

NEW
EDITION



A Complete Range of Solenoid Valves for Fluid Control

General Catalogue

- aerospace
- climate control
- electromechanical
- filtration
- fluid & gas handling
- hydraulics
- pneumatics
- process control
- sealing & shielding



ENGINEERING YOUR SUCCESS.



> 5,000

Product references

This catalogue is a comprehensive list of Parker FCDE products. It will help to identify appropriate valves and coils and enable the user to generate ordering numbers.

The catalogue is intended for use by Parker Sales personnel with the aim to select the most suitable solenoid valves for customers.



WARNING - USER RESPONSIBILITY

FAILURE OR IMPROPER SELECTION OR IMPROPER USE OF THE PRODUCTS DESCRIBED HEREIN OR RELATED ITEMS CAN CAUSE DEATH, PERSONAL INJURY AND PROPERTY DAMAGE.

- This document and other information from Parker-Hannifin Corporation, its subsidiaries and authorized distributors provide product or system options for further investigation by users having technical expertise.
- The user, through its own analysis and testing, is solely responsible for making the final selection of the system and components and assuring that all performance, endurance, maintenance, safety and warning requirements of the application are met. The user must analyze all aspects of the application, follow applicable industry standards, and follow the information concerning the product in the current product catalog and in any other materials provided from Parker or its subsidiaries or authorized distributors.
- To the extent that Parker or its subsidiaries or authorized distributors provide component or system options based upon data or specifications provided by the user, the user is responsible for determining that such data and specifications are suitable and sufficient for all applications and reasonably foreseeable uses of the components or systems.

Who we are?

The Fluid Control Division in Europe (FCDE) is a division of Parker Hannifin, the global leader in motion and control technologies.

FCDE core competences are the development and manufacturing of an extremely diverse range of fluid control products, including solenoid valves and pressure regulators.

Where we are?

Our European headquarters are located in Geneva, this is also where our R&D, Marketing, Application Support and Product Management functions are located.

FCDE Products are mainly manufactured at locations in Carouge (Geneva - Switzerland) and Gessate (Milan - Italy).

The Parker Sales Companies and comprehensive distribution network support you, wherever you are.

History

Parker FCDE has been a leading player in the manufacturing and development of solenoid valve technologies for over 60 years, with continuous research and development bringing innovative solutions to the marketplace, for example leading the way in the utilisation of synthetic ruby for critical water applications or the unsurpassed reliability and precision of our pressure regulators. The expertise accumulated and developed through the years is evident in the superior quality of FCDE solutions.

Markets

Our products and solutions are typically designed for markets including Industrial Equipment, Industrial Automation, Mobile, Transportation, Life Sciences, Beverage dispensing and for Fluid and Process Control.

Benefits

The modular concept of our products, having separate solenoid valves and electrical parts, provides the customer with increased flexibility by allowing numerous combinations. This additional flexibility can enable distributors to greater reduce valve inventory levels, whilst retaining the same number of capabilities. Parker also has unrivalled experience in developing customised product solutions complying with the highest technical, environmental, energy and service life requirements.



PARKER FCDE - GENEVA - SWITZERLAND



PARKER FCDE - MILAN - ITALY

GENERAL CATALOGUE FCDE

TABLE OF CONTENT

INTRODUCTION

Markets and applications.....	06
A complete range of solenoid valves.....	08
A modular concept.....	10
ATEX Certification.....	12
World class standards.....	13
How to use this catalogue.....	14
How to select a valve.....	16
How to order.....	18
How to use coil groups.....	24

2 WAY VALVES

Valves for dry or lubricated air, neutral gases and liquids.....	27
Valves for water and neutral liquids.....	79
Anti water hammer valves.....	113
Hot water and steam valves.....	125
Valves for hydraulic oil and neutral liquids (up to 100 bar).....	141
High corrosion resistant valves (303 Stainless Steel).....	157
High corrosion resistant valves (316L Stainless Steel).....	165
Oil burner valves.....	177
Fast switching valves.....	197
Valves for beverage dispensing - Lquipure®.....	201

3 WAY VALVES

Valves for dry or lubricated air, neutral gases and liquids.....	207
Valves for hydraulic oil and neutral liquids (up to 75 bar).....	247
High corrosion resistant valves (303 Stainless Steel).....	251
Valves for beverage dispensing - Lquipure®.....	257

2 & 3 WAY VALVES FOR TRANSPORTATION

2 way.....	265
3 way.....	271

5 WAY DISTRIBUTORS FOR PNEUMATIC APPLICATIONS

5 way pneumatic distributors (Pipe mounting/Sub-base mounting).....	275
---	-----

3 & 5 WAY PNEUMATIC DISTRIBUTORS FOR ACTUATION CONTROL

3 & 5 way pneumatic valves for actuator control (Pipe mounting)	301
3 & 5 way pneumatic valves for actuator control (NAMUR).....	333
316L Stainless Steel 3 & 5 way valves for actuator control (Pipe mounting and NAMUR).....	375

ELECTROPNEUMATIC PRESSURE REGULATORS

EPP4 Series - Basic, Comfort , Comfort ATEX Ranges.....	407
---	-----

COILS, HOUSINGS & ELECTRICAL PARTS

Introduction.....	439
Coils.....	441
Explosion Proof Electrical Parts.....	483
Housings.....	518
Coil Accessories	522
Explosive Environments.....	524
Guidance Chart for IS-Barriers.....	534

TECHNICAL INFORMATION ABOUT SOLENOID VALVES

Technical information about solenoid valves	537
---	-----

APPENDIX

Table of sub-bases for valves	558
Table of voltage codes for coils and electrical parts	564
Index by Coil Reference.....	568
Index by Coil Group	570
Index by Order Number	572
Index for Valves	574

MARKETS AND APPLICATIONS

In order to bring customers the best solution, Parker offers a wide range of products that can be divided into specific markets:

PROCESS CONTROL

- Valve Actuation
- Oil & Gas
- On & Off-Shore
- Petro-Chemical
- Pharmaceutical



INDUSTRIAL & AUTOMATION

- Compressors
- Blowing
- Textile
- Pressure Regulation



FOOD & BEVERAGE

- Professional Coffee Machines
- Sparkling Water
- Soft Drinks
- Water Dispensing



COOLING & CLIMATE CONTROL

- Water dispensing
- Cooling systems



TRANSPORTATION

- Trucks
- Trains
- Bus and Coach
- Marine
- Military
- Agriculture



LIFE SCIENCE

- Sterilizers / Autoclaves
- Breathing
- Water purification
- Table-top equipment



HEATING SYSTEMS

- Industrial Oil Burners
- Fuel Transfer
- Gas Transfer



A COMPLETE RANGE OF SOLENOID VALVES FOR FLUID CONTROL

2 WAY VALVES

- For dry or lubricated air, neutral gases and liquids
- For water and neutral liquids
- Anti water hammer
- Hot water and steam
- For hydraulic oil and neutral liquids (Max. 100 bar)
- High corrosion resistant (303 Stainless Steel) (316L Stainless Steel)
- Oil burner
- Fast switching
- Liquipure® for beverage dispensing



3 WAY VALVES

- For dry or lubricated air
- For hydraulic oil and neutral liquids (Max. 75 bar)
- High corrosion resistant (303 Stainless Steel)
- Liquipure® for beverage dispensing



2 & 3 WAY VALVES FOR TRANSPORTATION

- 2 way- direct and piloted
- 3 way- direct operated



5 WAY DISTRIBUTORS FOR PNEUMATIC APPLICATIONS

- Pipe mounted/ Sub-base mounting



3 & 5 WAY PNEUMATIC DISTRIBUTORS FOR ACTUATION CONTROL

- Pipe mounted
- NAMUR interface
- 316L Stainless Steel (Pipe mounted and with NAMUR interface)



COILS & ELECTRICAL PARTS

- Coils
- Housings
- Explosion-Proof Electrical Parts



EPP4 SERIES ELECTROPNEUMATIC PRESSURE REGULATORS

- Basic
- Comfort
- Comfort ATEX



A MODULAR CONCEPT FOR EVERY APPLICATION

CHOOSE BETWEEN:

Actuation Modes

- Direct Operated
- Magnalift
- Pilot Operated
- Manual Reset
- Externally Operated

Material Types

- Brass
- 303 Stainless St.
- 316L Stainless St.
- Anodized Aluminium
- Zinc Alloy
- POM

Mounting Solutions

- Pipe
- Sub-base
- NAMUR
- Banjo
- CETOP
- ISO

Control Functions

- Normally Closed
- Normally Open
- Universal
- Control by Electric Impulse
- Dual Solenoids
- PWM

Internal Design

- Piston
- Poppet
- Diaphragm
- Spool

Seals

- FKM
- NBR
- EPDM
- Ruby
- PUR
- PCTFE...

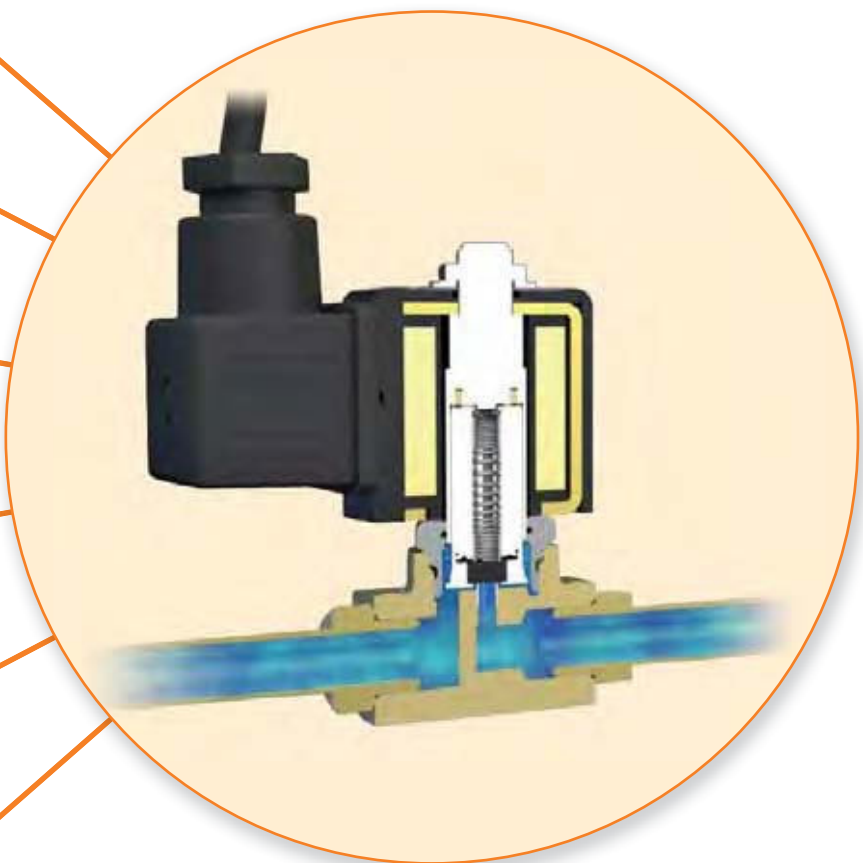

ATEX CERTIFICATION



ELECTRICAL PART ATEX CERTIFICATION

A selection of FCDE electrical parts conform to the terms of the 94/9/EC directive and are made for potentially explosive environments - zone 0/20, 1/21 and 2/22.

Within the coil section, the presence of the ATEX logo  shows that the coil is ATEX approved.



MECHANICAL PART ATEX CERTIFICATION

A selection of FCDE mechanical parts conform to the terms of the 94/9/CE directive specific to non electrical equipment for use within potentially explosive environments - zones 0/20, 1/21 and 2/22.

NAMUR & piped valve ranges now include a marking which indicates mechanical ATEX approval.

Within the valve section, the presence of the ATEX logo  shows that the valve is ATEX approved.



SOLENOID VALVE CERTIFICATION

When both the electrical and mechanical part are ATEX approved, the solenoid valve can be used in explosive atmospheres.

The solenoid valve will be delivered assembled and tested.



PARKER FCDE IS MEETING WORLD CLASS STANDARDS

QUALITY STANDARDS:

- ISO 9001
- ISO 14001
- ISO TS 16949



CERTIFICATIONS AND APPROVALS:

Our products have been approved and are compliant with the relevant market requirements including:

- CE
- ATEX
- RoHS
- UL
- Reach
- IECEx
- CSA
- Gost
- SVGW
- DIN
- AGA
- TUV
- Kosha
- IMQ
- NSF
- VDE



HOW TO USE THIS CATALOGUE

This catalogue is a comprehensive list of Parker FCDE products. It will help to identify appropriate valves and coils and enable the user to generate ordering numbers. The catalogue is intended for use by Parker Sales personnel with the aim to select the most suitable solenoid valves for customers.

This catalogue is split by product family. You will find a summary page at the beginning of each valve section. For ease of use, each valve section is divided by application.

On the first page of each Application section, you will find an overview of the products within and their technical characteristics, to guide you to the relevant page (example below):

SECTION SUMMARY PAGE

2 WAY VALVES

VALVES FOR DRY OR LUBRICATED AIR, NEUTRAL GASES AND LIQUIDS

2/2

Actuation	Body	Function	Port Size	Orifice (mm)	Flow Factor Kv(1/min)	Min. (bar)	Max. (bar)	Temp. (°C)	Page Panel Valve	Page Panel Locust® Valve	
Direct Operated	Brass/Pipe mounting	Normally Closed	1/8"	1.2 to 3	4.5	70	140	50	32	32	
			1/4"	1.2 to 5	13	100	140	30	30		
			3/8"	4 to 6	12	10	120	-	36	36	
		Normally Open	1/8"	2.5	3.5	30	140	-	40	40	
			1/4"	1.5 to 3	4	40	140	38	40		
			Control by Electric Impulse	1/4"	3 to 5	11	20	100	-	40	40
Magnalift	Brass/Pipe mounting	Brass/Sub-base mounting	Normally Closed	5 mm	1.5 to 3	4.5	100	130	-	42	
		Normally Open	5 mm	1.5	1.5	20	120	-	44	44	
Pilot Operated	Brass/Pipe mounting	Normally Closed	1/4"	8 to 12	36	40	120	-	56	56	
			3/8"	11 to 13	50	40	120	54	58		
			1/2"	11 to 15	60	40	120	54	60		
			3/4"	15 to 20	135	40	120	54	62		
			1"	18 to 28	270	16	120	54	64		
			1 1/2"	40	425	16	120	-	66	66	
			2"	40	540	10	120	-	68	68	
			Normally Open	1/4"	8	36	40	140	-	70	70
			3/8"	11 to 13	50	40	140	68	70		
		1/2"	13 to 15	60	40	140	68	70			
		3/4"	15 to 20	135	40	120	68	72			
		1"	25 to 40	420	16	120	68	72			
		1 1/4"	28	270	16	120	-	72	72		
		1 1/2"	40	420	12	100	-	72	72		
		2"	40	540	12	120	-	72	72		
		Control by Electric Impulse	1/4"	12	32	12	100	-	74	74	
		3/8"	12	45	12	100	-	74	74		
		1/2"	12	50	12	100	-	74	74		
3/4"	18	100	12	100	-	74	74				
1"	18	110	12	100	-	74	74				
Brass/Sub-base mounting	Normally Closed	14 mm	14	45	40	140	-	76	76		
	Normally Open	14 mm	14	46	40	120	-	76	76		

Parker 27 Parker Hannifin Corporation Fluid Control Division Europe General Catalogue FCDE/0110/UK/V2.0

For further technical information regarding Actuation, Body and Function, please refer to the technical information section at the end of the catalogue.

Applicable Markets for this valve category

Applicable Approvals within this page

Quick selection table with Min/Max values for all valves on the page

SECTION PRODUCT PAGE

2 WAY VALVES

21/2" HOT WATER AND STEAM VALVES

MAGNALIFT

BRASS PIPE MOUNTING

NORMALLY CLOSED

Port size	Orifice Ø	Flow factors	Operating pressure		Fluid Temp.		Seat Seal	Parker LUCIFER® Valves			Power	Coil Group	Dwg. No.	
			Min	Max	Valve Ref.	Housing Ref.		Coil Ref.						
3/8"	15	65 3.9	0	10	0	100	EPDM	22161303	2995	481865	8	-	2.0	3732
								22161303	4270	481000	8	-	2.0	3732
								22161303	4270	486265	14	14	2.0	3732
1/2"	15	65 3.9	4500	0	10	-10	100	22161330	2995	481865	8	9	2.1	3732
								22161330	-	482070	9	9	2.1	3732
								22161330	-	482190	11	9	2.1	3732
3/4"	15	65 3.9	4500	0	10	-10	120	22161303	2995	481865	8	-	2.0	3732
								22161303	4270	481000	8	-	2.0	3732
								22161303	4270	486265	14	14	2.0	3732
1"	15	80 4.8	0	10	0	100	EPDM	22161603	2995	481865	8	-	2.0	3444
								22161603	4270	481000	8	-	2.0	3444
								22161603	4270	486265	14	14	2.0	3444
1"	15	80 4.8	0	10	0	100	EPDM	22161703	2995	481865	8	-	2.0	3445
								22161703	4270	481000	8	-	2.0	3445
								22161703	4270	486265	14	14	2.0	3445

Notes:
1. Valves with model number ending in 30 or 31 are mainly equipped with electrical parts for explosion protection or with standard DC coils.

2 WAY VALVES

For this page	Port size	Orifice (mm)	Kv (Inch)	MOPD (bar)	Fluid Temp (°C)	Amb Temp (°C)
From	3/8"	15	65	4	-10	-10
To	1"	15	80	10	140	50

Ordering information

ISO Symbol

A choice of Coil Groups compatible with the selected valve.

Dimensional 2D* and 3D drawings

* 2D drawing shown always corresponds to the standard coil.



HOW TO SELECT A VALVE

Once you are in the selected family **1** and application **2**.

The table is designed to help you navigate to the products matching your criteria.

First decide the actuation **3**, then move across the table selecting your body material **4**, function **5** and technical requirements **6**.

After you have found products fitting within your specification, please go to the corresponding page number in the final column **7**, here you will find a selection of products that match your criteria.

1 SELECT PRODUCT FAMILY

2 SELECT APPLICATION

3 SELECT ACTUATION

4 SELECT BODY

5 SELECT FUNCTION

6 SELECT TECHNICAL DATA

7 SELECT CORRESPONDING PAGE

1

2 WAY VALVES

VALVES FOR DRY OR LUBRICATED AIR, NEUTRAL GASES AND LIQUIDS

2



2/2

Actuation	Body	Function	Port Size	Orifice (mm)	Flow Factor Kv(l/min)	MOPD (bar)	Max Fluid Temp. (°C)	Page Parker Valves	Page Parker LUCIFER® Valves			
Direct Operated	Brass/Pipe mounting	Normally Closed	1/8"	1.2 to 3	4.5	70	140	28	32			
			1/4"	1.2 to 5	13	100	140	30	32			
			3/8"	4 to 6	12	10	120	-	36			
			1/2"	8.5 to 11	36	4	120	-	36			
			1/8"	2.5	3.5	30	140	-	40			
	Magnalift	Brass/Pipe mounting	Normally Open	1/4"	1.5 to 3	4	40	140	38	40		
				1/4"	3 to 5	11	20	100	-	40		
				Control by Electric Impulse	1/4"	3 to 5	11	20	100	-	40	
				Brass/Sub-base mounting	Normally Closed	5 mm	1.5 to 3	4.5	100	130	-	42
					Normally Open	5 mm	1.5	1.5	20	120	-	44
Brass/Pipe mounting		Normally Closed	3/8"	13 to 15	65	20	140	46	48			
			1/2"	13 to 15	65	20	140	46	48			
			3/4"	15 to 20	100	20	140	46	50			
			1"	15 to 25	170	20	140	46	52			
			Pilot Operated	Brass/Pipe mounting	Normally Closed	1/4"	8 to 12	40	120	-	-	-
3/8"	11 to 13	50				120	54	54				
1/2"	11 to 15	60				120	54	54				
3/4"	15 to 20	100				40	120	54	54			
1"	18 to 28	270				16	120	54	64			
1 1/2"	40	425				16	120	-	66			
2"	40	540				16	120	-	66			
Normally Open	1/4"	8				36	40	140	-	70		
	3/8"	11 to 13				50	40	140	68	70		
Brass/Sub-base mounting	Normally Open	1/2"				13 to 15	60	40	140	68	70	
		3/4"		15 to 20	135	40	120	68	72			
		1"		25 to 40	420	16	120	68	72			
		1 1/4"		28	270	16	120	-	72			
		1 1/2"		40	420	12	100	-	72			
		2"		40	540	12	120	-	72			
		Control by Electric Impulse		1/4"	12	32	12	100	-	74		
				3/8"	12	45	12	100	-	74		
				1/2"	12	50	12	100	-	74		
				3/4"	18	100	12	100	-	74		
Brass/Sub-base mounting	Normally Closed	1"		18	110	12	100	-	74			
		14 mm	14	45	40	140	-	76				
	Brass/Sub-base mounting	Normally Open	14 mm	14	46	40	120	-	76			



HOW TO ORDER

BETWEEN TWO PRODUCT RANGES

7

SELECT CORRESPONDING

Parker [Blue Table]

2 WAY VALVES																	
2/2 VALVES FOR DRY OR LUBRICATED AIR, NEUTRAL GASES AND LIQUIDS DIRECT OPERATED																	
BRASS PIPE MOUNTING																	
NORMALLY CLOSED																	
Port size	Orifice Ø	Flow factors			Operating Pressure Differential		Fluid Temp.		Seat Seal	Parker Valves			Power		Coil Group	Dwg. No.	
		Kv	Qn	Qn	AC	DC	Min	Max		Valve Order Number	Valve Type	Coil Type	AC W	DC W			
1/8"	2.5	3.3	0.20	-	0	-	5	-10	140	FKM	363380	PM146FV	ZB12	-	12	20.1/20.2	034
	3	4.5	0.27	-	0	7	-	-10	140	FKM	363390	PM146HW	ZB09	9	-	20.1/20.2	034
	3	4.5	0.27	-	0	-	2	-10	140	FKM	363390	PM146HW	ZB12	-	12	20.1/20.2	034
1/4"	2.5	2.2	0.13	-	0	10	-	-10	140	FKM	398006	N74.4WV	WB4.5 230/50-60	4.5	-	1.3	065
	2.5	2.2	0.13	-	0	10	-	-10	140	FKM	398007	N74.4WV	WB4.5 240/50-60	4.5	-	1.3	065
	2.5	2.2	0.13	-	0	-	4	-10	140	FKM	398008	N74.4WV	WB5.0 120C	-	5	1.3	065
	2.5	2.2	0.13	-	0	-	4	-10	140	FKM	398010	N74.4WV	WB5.0 240C	-	5	1.3	065
	2.5	2.2	0.13	-	0	19	-	-10	140	FKM	398009	N74.4WV	WB4.5 230/50-60	4.5	-	1.3	065
	2.5	2.2	0.13	-	0	19	-	-10	140	FKM	398010	N74.4WV	WB5.0 240C	-	5	1.3	065

- Designed for Industrial Automation applications
- ATEX applications only if indicated 

• Please order: Valve + Coil

Order Separately

1

VALVE

Valve order example:
363380

2

COIL

Coil order example:
304002

For more details, see page 20:

How to Order Parker Valves

CAUTION: For N74, N79, 131.4, 131, 175, 180, 161 valves series, the valve order number indicates assembled valve **and** coil for the voltage shown.

IMPORTANT: For assembled solenoid valves, please consult your local sales office.

Parker Lucifer® [Orange Table]

2 WAY VALVES

2/2

VALVES FOR DRY OR LUBRICATED AIR, NEUTRAL GASES AND LIQUIDS
DIRECT OPERATED

BRASS
PIPE MOUNTING

NORMALLY CLOSED



Port size	Orifice Ø	Flow factors			Operating Pressure Differential		Fluid Temp.		Seat Seal	Parker LUCIFER® Valves			Power		Coil Group	Dwg. No.	
		Kv	KV	Qn	Min	Max	Min	Max		Valve Ref.	Housing Ref.	Coil Ref.	AC W	DC W			
3/8"	4	7.5	0.45	480	0	10	4	-10	100	FKM	121K3206	2995	481865	8	9	2.0	3551
	4	7.5	0.45	480	0	10	5	-10	120	FKM	121K3206	4270	481000	8	8	2.0	3551
	4	7.5	0.45	480	0	10	10	-10	120	FKM	121K3206	4270	488265	14	14	2.0	3551
	5	11	0.66	750	0	7	2	-10	100	FKM	121K3106	2995	481865	8	9	2.0	3551
	5	11	0.66	750	0	7	2.8	-10	120	FKM	121K3106	4270	481000	8	8	2.0	3551
	5	11	0.66	750	0	7	5	-10	120	FKM	121K3106	4270	488265	14	14	2.0	3551
3/8"	6	12	0.72	1100	0	5	1.1	-10	100	FKM	121K3306	2995	481865	8	9	2.0/142	3551
	6	12	0.72	1100	0	5	1.5	-10	120	FKM	121K3306	4270	488265	14	14	2.0/142	3551

- Thanks to the modular concept, a wide range of electrical parts can be used including ATEX, IECEX, IP67, H class, reduced power, UL/VDE approved
- For demanding applications in reliability, performance, quality
- High quality materials and execution

• **Please order:**
Valve + Housing + Coil

One Order

1

VALVE

2

HOUSING

3

COIL



For more details, see page 22:

**How to Order
Parker Lucifer®
Solenoid Valves**

Valve and coil order example:

1

121K3206
Valve Reference

2

2995
Housing

3

481865A2
Coil and Voltage Code

HOW TO ORDER PARKER VALVES

A PARKER SOLENOID VALVE IS COMPOSED OF 2 ELEMENTS:

The Valve ① and the Coil ②

① Use the valve order number (6 digits) to order the valve.

Valve Order Number
363380
363390
363390

Valve order N° example:
363380

For a given valve, several coil types are being suggested.

For a wider choice, the selected valve is also compatible with every other coil from the same coil group.

2 WAY VALVES

2/2

VALVES FOR DRY OR LUBRICATED AIR, NEUTRAL GASES AND LIQUIDS
DIRECT OPERATED

BRASS
PIPE MOUNTING

NORMALLY CLOSED



Port size	Orifice Ø	Flow factors			Operating Pressure Differential		Fluid Temp.		Seat Seal	Parker Valves			Power		Coil Group	Dwg. No.
		Kv	Kv	Qn	Min	Max	Min	Max		Valve Order Number	Valve Type	Coil Type	AC W	DC W		
1/8"	2.5	3.3	0.20	-	0	5	-10	140	FKM	363380	PM146FV	ZB12	-	12	20.1/20.2	034
	3	4.5	0.27	-	0	7	-10	140	FKM	363390	PM146HV	ZB09	9	-	20.1/20.2	034
	3	4.5	0.27	-	0	2	-10	140	FKM	363390	PM146HV	ZB12	-	12	20.1/20.2	034
	2.5	2.2	0.13	-	0	10	-10	140	FKM	398006	N74.4WV	WB4.5 230/50-60	4.5	-	1.3	065
1/4"	2.5	2.2	0.13	-	0	10	-10	140	FKM	398007	N74.4WV	WB4.5 240/50-60	4.5	-	1.3	065
	2.5	2.2	0.13	-	0	4	-10	140	FKM	398008	N74.4WV	WB5.0 120C	-	5	1.3	065
	2.5	2.2	0.13	-	0	4	-10	140	FKM	398010	N74.4WV	WB5.0 240C	-	5	1.3	065
	2.5	2.2	0.13	-	0	19	-10	140	FKM	398012	N74.4WV	WB8.0 230/50-60	8	-	1.3	065
	3	4.5	0.27	-	0	7	-10	140	FKM	363444	PM146YV	ZB09	9	-	20.1/20.2	035
	3	4.5	0.27	-	0	2	-10	140	FKM	363444	PM146YV	ZB12	-	12	20.1/20.2	035
	4.5	9	0.53	-	0	6	-10	140	FKM	363457	PM146.3KV	ZB14	14	-	20.2	035
	4.5	9	0.53	-	0	2.5	-10	140	FKM	363457	PM146.3KV	ZB16	-	16	20.2	035
	6	13	0.75	-	0	6	-10	140	FKM	363467	PM146.3ABV	ZB14	14	-	20.2	035
	6	13	0.75	-	0	1	-10	140	FKM	363467	PM146.3ABV	ZB16	-	16	20.2	035

Notes:
1. Ordering number is for an assembled valve and coil, with the voltage shown.

30

Parker Hannifin Corporation
Fluid Control Division Europe
General Catalogue FCDE/0110/UK/V2.0

HOW TO ORDER PARKER COILS

2 Use the coil order number (6 digits) to order the coils

Choose the coil and use the 6 digits order number to order.

VAC/Hz	Order Number
ZB09 24/50-60	304004
ZB09 12/50-60	304002
ZB09 230/50-60	304012

Coil order N° example:
304002

COILS

COIL GROUP
20.1 COILS FOR DIN PLUG CONNECTION



ZB COIL SERIES

These coils can be mounted with every Parker solenoid valves corresponding to the specified Coil Group. See column "Coil Group" within valve pages.
Coil manufactured with H class copper wire, moulded in thermoplastic material polyester with 30% glass fiber.
IP65 protection rate with EN 175301-803:2006-A. Three pin connector.
This coil conforms to the IEC/GENELEC safety standards and complies with European low-voltage directive.
For UL recognized version: UL file MH19410.
DIN plug connector to be ordered separately (see coil accessories section).

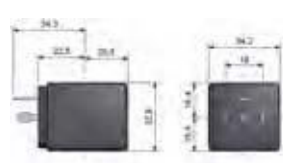

Specification	Standard	UL recognized version				
Reference (without DIN plug)	ZB09/ZB12	ZB09 for AC only				
Coil Group	20.1					
Degree of protection	IP65 according to IEC / EN 60529 standards (with DIN plug and gasket)					
Degree of insulation	F 155°C					
Electrical connection	The coil is connected with a 2 P = E plug according to EN 175301-803 - type A					
Ambient temperature	-10°C to +50°C The application is limited also by the temperature range of the valve.					
Elect. Power	DC P (cold) 20°C	12 W				
	AC P (cold) 20°C	9 W				
	Attraction coil	25 VA				
Weight	130 g					
Voltages "Un"	VAC/Hz	Order Number	VDC	Order Number	VAC/Hz	Order Number
	-10% to +10% of Un for AC -5 % to + 10 % for Un DC.	ZB09 24/50-60 304004 ZB09 12/50-60 304002 ZB09 230/50-60 304012 ZB09 115/50-60 304010 ZB09 100/50-60 304009 ZB09 240/50-60 304014 ZB09 48/50-60 304008 ZB09 110-120/60 304011 ZB09 380/50-60 304016	ZB12 12DC 304018 ZB12 24DC 304020 ZB12 110DC 304022 ZB12 48VDC 304021	ZB09 24/60 304048 ZB09 110-120/60 304011 ZB09 208-240/60 304051		

To Order a Coil: Use 6 digits ordering number - Code Example: ZB09 24/50-60 = 304004.
More voltage possibilities can be found in the table of voltage codes at the end of the coil section.

Parker 460 Parker Hannifin Corporation Fluid Control Division Europe General Catalogue FCDE/0110/UK/V2.0

Coil section at the end of the catalogue

IMPORTANT: For assembled solenoid valves, please consult your local sales office.

HOW TO ORDER PARKER LUCIFER® SOLENOID VALVES

A PARKER LUCIFER® SOLENOID VALVE IS COMPOSED OF 3 ELEMENTS:

The Valve ① + Housing ② + Coil ③

1. Choose the valve reference
2. Choose the housing
3. Choose the coil

① Choose the Valve Reference.

Valve Ref.

121K3206

121K3206

121K3206

② Select the housing depending on the protection level (IP 44 to IP 67 found in the coil section)

Housing Ref.

2995

4270

4270

2 WAY VALVES

2/2 VALVES FOR DRY OR LUBRICATED AIR, NEUTRAL GASES AND LIQUIDS
DIRECT OPERATED

BRASS
PIPE MOUNTING
NORMALLY CLOSED



Port size	Orifice Ø	Flow factors			Operating Pressure Differential		Fluid Temp.		Seat Seal	Parker LUCIFER® Valves			Power		Coil Group	Dwg. No.	
		Kv	KV	Q _n	AC	DC	Min	Max		Valve Ref.	Housing Ref.	Coil Ref.	AC W	DC W			
3/8"	4	7.5	0.45	480	0	10	4	-10	100	FKM	121K3206	2995	481865	8	9	2.0	3551
											121K3206	4270	481000	8	8		
											121K3206	4270	486265	14	14		
	5	11	0.66	750	0	7	2	-10	100	FKM	121K3106	2995	481865	8	9	2.0	3551
											121K3106	4270	481000	8	8		
											121K3106	4270	486265	14	14		
	6	12	0.72	1100	0	5	1.1	-10	100	FKM	121K3306	2995	481865	8	9	2.0/14.2	3551
											121K3306	4270	481000	8	8		
											121K3306	4270	486265	14	14		
	8.5	25	1.5	1600	0	1.1	0.5	-10	100	FKM	E121K46	2995	481865	8	9	2.0	3427
											E121K46	4270	486265	14	14		
											E121K46	4270	481000	8	8		
11	36	2.16	2500	0	0.7	0.3	-10	100	FKM	E121K45	2995	481865	8	9	2.0	3427	
										E121K45	4270	481000	8	8			
										E121K45	4270	486265	14	14			
1/2"	11	36	2.16	2500	0	1.2	0.35	-10	120	FKM	E121K45	4270	481000	8	8	2.0	3427
											E121K45	4270	481000	8	8		
											E121K45	4270	486265	14	14		

Notes:
1. Valve compatible with water only up to 40°C
2. With manual override

Parker

36

Parker Hannifin Corporation
Fluid Control Division Europe
General Catalogue FCDE/0110/UK/V2.0

For a given valve, several coil types are being suggested.

For a wider choice, the selected valve is also compatible with every other coil from the same coil group.

Parker Lucifer® coils are available in many different voltages.
Choose the one you need by putting the voltage code at the end of your ordering number.

3 Choose the coil and voltage code.

Coil Ref.

481865

Voltage Code

VAC/Hz	Code
24/50	A2
48/50	A4
110/50	A5
220-230/50	3D

Valve and coil order example:



121K3206 - 2995 - 481865A2

Valve Reference

Housing

Coil and Voltage Code

COILS

COIL GROUP
2.0/2.1 COILS FOR DIN PLUG CONNECTION

RoHS CE D'E

COILS 32 mm

These coils can be mounted with every Parker solenoid valves responding to the specified Coil Group. See column "Coil Group" within valve pages. This is an encapsulated assembly comprising a coil, integral magnetic iron path and snap-on plug connection. The synthetic material encapsulation provides an effective compact housing, offering full protection against dust, oil, water, etc. Ease of mounting in confined space - offers shock and corrosion protection - simplifies conversion of existing equipment to other requirements, etc. Coils conform to the IEC/ENEC safety standards and complies with European low-voltage directives.



Specification	Standard	Double frequency					
Ref. (without DIN plug)	481865	483510					
Ref. (with DIN plug)	482725	482635					
Coil Group	2.0 / 2.1						
Degree of protection	IP65 according to IEC / EN 60529 standards (with DIN plug).						
Class of insulation	F 155°C						
Electrical connection	The coil is connected with a 2 P + E plug according to EN 175301-803 type A						
Ambient temperature	-40°C to +50°C The application is limited also by the temperature range of the valve.						
Elect. Power	DC Pn (in)	9 W					
	P (cold) 20°C	12 W					
	AC Pn (holding)	8 W					
Attraction cold	26 VA (9 W)	32 VA (10 W)					
Weight	130 g (without plug)						
Voltages "Un"	VAC/Hz	Code	VDC	Code	VAC/Hz	Code	
	-10% to +10% of the Un	24/50	A2	24	C2	24/50, 24/60	P0
		48/50	A4	48	C4	48/50, 48/60	S4
		110/50	A5	110	C5	110-115/50, 120/60	S5
	220-230/50	3D			220-240/50, 240/60	S6	

To Order a Coil choose Coil Ref + Voltage Code, example: 481865 for 24 VDC = **481865C2**
More voltage possibilities can be found in the table of voltage codes at the end of the coil section.

These coils must be used with suitable housings, see example below:

The coil assembly kit **Ref. 2995** corresponds to the "housing" of Lucifer® valve numbering system (Valve - housing - coil/voltage). It is composed of a nameplate giving details of the valve type, a round washer and a nut to ensure the fixing between 32 mm coil and the valve.

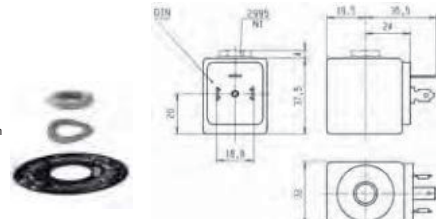

Parker

446

Parker Hannifin Corporation
Fluid Control Division Europe
General Catalogue FCDE/0110/UK/V2.0

IMPORTANT: Valve, Housing or Coil can be ordered separately for use as a replacement or spare part.

HOW TO USE COIL GROUPS

WITHIN A VALVE PAGE

One of Parker's strengths is the modularity, adaptability and flexibility of our products. When you select a solenoid valve, the coils displayed in the table have been chosen as they will fulfill the majority of application requirements.

Parker LUCIFER® Valves		
Valve Ref.	Housing Ref.	Coil Ref.
121K3206	2995	481865
121K3206	4270	481000
121K3206	4270	486265

However, in some specific cases, you will need special features that will lead you to choose another coil.

Groups have been created in order to facilitate the selection of a compatible coil with the chosen valve.

Coil Group
2.0
2.0
2.0

Example:

The valve 121K3206 is proposed with the coil 481865 but you can also choose any coil from the group 2.0.

2 WAY VALVES

2/2

VALVES FOR DRY OR LUBRICATED AIR, NEUTRAL GASES AND LIQUIDS
DIRECT OPERATED

BRASS
PIPE MOUNTING

NORMALLY CLOSED

Port size	Orifice Ø	Flow factors		Qn U/min	Operating Pressure Differential Max(MOPD)			Fluid Temp.		Seat Seat	Parker LUCIFER® Valves			Power		Coil Group	Dwg. No.
		Kv	KV		Min	Max(MOPD)	DC bar	Min	Max		Valve Ref.	Housing Ref.	Coil Ref.	AC W	DC W		
3/8"	4	7.5	0.45	0	0	10	4	-10	100	FKM	121K3206	2995	481865	8	9	2.0	3551
	4	7.5	0.45	480	0	10	4	-10	120	FKM	121K3206	4270	481000	8	8	2.0	3551
	4	7.5	0.45	480	0	10	10	-10	120	FKM	121K3206	4270	486265	14	14	2.0	3551
	5	11	0.66	750	0	7	2	-10	100	FKM	121K3106	2995	481865	8	9	2.0	3551
	5	11	0.66	750	0	7	2.8	-10	120	FKM	121K3106	4270	481000	8	8	2.0	3551
	5	11	0.66	750	0	7	5	-10	120	FKM	121K3106	4270	486265	14	14	2.0	3551
1/2"	6	12	0.72	1100	0	5	1.5	-10	120	FKM	121K3306	2995	481865	8	9	2.0/14.2	3551
	6	12	0.72	1100	0	5	3	-10	120	FKM	121K3306	4270	481000	8	8	2.0/14.2	3551
	6	12	0.72	1100	0	5	3	-10	120	FKM	121K3306	4270	486265	14	14	2.0/14.2	3551
	8.5	25	1.5	1600	0	1.1	0.5	-10	100	FKM	E121K46	2995	481865	8	9	2.0	3427
	8.5	25	1.5	1600	0	2.2	0.5	-10	120	FKM	E121K45	2995	481865	8	8	2.0	3427
	8.5	25	1.5	1600	0	4	1.2	-10	120	FKM	E121K46	4270	486265	14	14	2.0	3427
1/2"	11	36	2.16	2500	0	0.7	0.3	-10	100	FKM	E121K45	2995	481865	8	9	2.0	3427
	11	36	2.16	2500	0	1.2	0.35	-10	120	FKM	E121K45	4270	481000	8	8	2.0	3427
	11	36	2.16	2500	0	2.5	0.7	-10	120	FKM	E121K45	4270	486265	14	14	2.0	3427

Notes:
 1. Valve compatible with water up to 40°C.
 2. With manual override.

36

Parker Hannifin Corporation
 Fluid Control Division Europe
 General Catalogue FCDE/0110/UK/V2.0

It is also possible to choose the coil first and then select the valve using coil groups.

HOW TO USE COIL GROUPS

WITHIN A COIL PAGE

The coil section is at the end of the catalogue and displays the specifications of each coil, along with the reference number, class of insulation, ambient temperature, electrical power and weight.

2.0 / 2.1

As indicated before, the valve 121K3206 is proposed with coil 481865 but is also compatible with the 2.0 coil group. This means the coil 482725 is also compatible with the chosen valve as it is within this group.

When referring to the coil section you will find the coil group for each coil. This allows you to discover which other coils are compatible with the valve you have chosen.

COILS



COIL GROUP

2.0/2.1

COILS FOR
DIN PLUG CONNECTION

COILS 32 mm

These coils can be mounted with every Parker solenoid valves corresponding to the specified Coil Group. See column "Coil Group" within valve pages.

This is an encapsulated assembly comprising a coil, integral magnetic iron path and snap-on plug connection.

The synthetic material encapsulation provides an effective compact housing, offering full protection against dust, oil, water, etc.

Ease of mounting in confined space - offers shock and corrosion protection - simplifies conversion of existing equipment to other requirements, etc.

Coils conform to the IEC/CENELEC safety standards and complies with European low-voltage directive.



Specification	Standard	Double frequency	
Ref. (without DIN plug)	481865	483510	
Ref. (with DIN plug)	482725	482635	
Coil Group	2.0 / 2.1		
Degree of protection	IP65 according to IEC / EN 60529 standards (with DIN plug).		
Class of insulation	F 155°C		
Electrical connection	The coil is connected with a 2 P + E plug according to EN 175301-803 type A		
Ambient temperature	-40°C to +50°C The application is limited also by the temperature range of the valve.		
Elect. Power	DC Pn (hot)	9 W	
	P (cold) 20°C	12 W	
	AC Pn (holding)	8 W	
	Attraction cold	26 VA (9 W) 32 VA (10 W)	
Weight	130 g (without plug)		
Voltages "Un"	VAC/Hz	Code	VDC
	-10% to +10% of the Un	A2	24
		A4	48
		A5	110
		3D	
	C2	24/50, 24/60	Code
	C4	48/50, 48/60	P0
	C5	110-115/50, 120/60	S4
		220-240/50, 240/60	S5
			S6

To Order a Coil choose Coil Ref + Voltage Code, example: 481865 for 24 VDC = **481865C2**

More voltage possibilities can be found in the table of voltage codes at the end of the coil section.

These coils must be used with suitable housings, see example below:

The coil assembly kit **Ref. 2995** corresponds to the "housing" of Lucifer® valve numbering system (Valve - housing - coil/voltage). It is composed of a nameplate giving details of the valve type, a round washer and a nut to ensure the fixing between 32 mm coil and the valve.

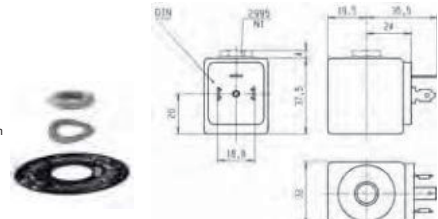

446

Parker Hannifin Corporation
 Fluid Control Division Europe
 General Catalogue FCDE/0110/UK/V2.0

2 WAY VALVES



VALVES FOR DRY OR LUBRICATED AIR, NEUTRAL GASES AND LIQUIDS



2/2

Actuation	Body	Function	Port Size	Orifice (mm)	Flow Factor Kv(l/min)	MOPD (bar)	Max Fluid Temp. (°C)	Page Parker Valves	Page Parker LUCIFER® Valves		
Direct Operated	Brass/Pipe mounting	Normally Closed	1/8"	1.2 to 3	4.5	70	140	28	32		
			1/4"	1.2 to 5	13	100	140	30	32		
			3/8"	4 to 6	12	10	120	-	36		
		Normally Open	1/2"	8.5 to 11	36	4	120	-	36		
			1/8"	2.5	3.5	30	140	-	40		
			1/4"	1.5 to 3	4	40	140	38	40		
		Control by Electric Impulse	1/4"	3 to 5	11	20	100	-	40		
			5 mm	1.5 to 3	4.5	100	130	-	42		
		Magnalift	Brass/Pipe mounting	Normally Closed	3/8"	13 to 15	65	20	140	46	48
					1/2"	13 to 15	65	20	140	46	48
Pilot Operated	Brass/Pipe mounting	Normally Closed	3/4"	15 to 20	100	20	140	46	50		
			1"	15 to 25	170	20	140	46	52		
			1/4"	8 to 12	36	40	120	-	56		
			3/8"	11 to 13	50	40	120	54	58		
			1/2"	11 to 15	60	40	120	54	60		
			3/4"	15 to 20	135	40	120	54	62		
			1"	18 to 28	270	16	120	54	64		
			1 1/2"	40	425	16	120	-	66		
			2"	40	540	16	120	-	66		
			Normally Open	1/4"	8	36	40	140	-	70	
		3/8"		11 to 13	50	40	140	68	70		
		1/2"		13 to 15	60	40	140	68	70		
		3/4"		15 to 20	135	40	120	68	72		
		1"		25 to 40	420	16	120	68	72		
		1 1/4"		28	270	16	120	-	72		
		1 1/2"		40	420	12	100	-	72		
		2"		40	540	12	120	-	72		
		Control by Electric Impulse		1/4"	12	32	12	100	-	74	
				3/8"	12	45	12	100	-	74	
			1/2"	12	50	12	100	-	74		
3/4"	18		100	12	100	-	74				
Brass/Sub-base mounting	Normally Closed	14 mm	14	45	40	140	-	76			
		14 mm	14	46	40	120	-	76			

2/2

VALVES FOR DRY OR LUBRICATED AIR, NEUTRAL GASES AND LIQUIDS
DIRECT OPERATED



Commercial Equipment



Industrial Equipment



Heating Systems

BRASS
PIPE MOUNTING

NORMALLY CLOSED

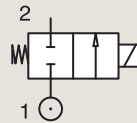

Port size	Orifice Ø	Flow factors			Operating Pressure Differential			Fluid Temp.		Seat Seal	Parker Valves			Power		Coil Group	Dwg. No.
		Kv	KV	Qn	Min	Max(MOPD)	Min	Max	Valve Order Number		Valve Type	Coil Type	AC W	DC W			
BSP	mm	l/min	m³/h	m³/h	bar	AC bar	DC bar	°C	°C								
1/8"	1.2	0.7	0.04	-	0	20	-	-10	140	FKM	398018 ₁	N74.4IV	WB4.5 115/50-60	4.5	-	1.3	064
	1.5	1	0.06	-	0	20	-	-10	140	FKM	398017 ₁	N74.4AV	WB4.5 115/50-60	4.5	-	1.3	064
	1.5	1	0.06	-	0	20	-	-10	140	FKM	398014 ₁	N74.4AV	WB4.5 230/50-60	4.5	-	1.3	064
	1.5	1	0.06	-	0	20	-	-10	140	FKM	398030 ₁	N74.4AV	WB4.5 24/50-60	4.5	-	1.3	064
	1.5	1	0.06	-	0	-	10	-10	140	FKM	398034 ₁	N74.4AV	WB5.0 12DC	-	5	1.3	064
	1.5	1	0.06	-	0	-	10	-10	140	FKM	398016 ₁	N74.4AV	WB5.0 24DC	-	5	1.3	064
	1.5	1	0.06	-	0	-	10	-10	140	FKM	398013 ₁	N74.4AVA.5	WB5.0 5.0 24DC	-	5	1.3	064
	1.5	1.5	0.09	-	0	20	-	-10	140	FKM	363378	PM146BV	ZB09	9	-	20.1/20.2	034
	1.5	1.5	0.09	-	0	-	18	-10	140	FKM	363378	PM146BV	ZB12	-	12	20.1/20.2	034
	2.5	2.2	0.13	-	0	10	-	-10	140	FKM	398026 ₁	N74.4FV	WB4.5 115/50-60	4.5	-	1.3	064
	2.5	2.2	0.13	-	0	10	-	-10	140	FKM	398003 ₁	N74.4FV	WB4.5 115/60	4.5	-	1.3	064
	2.5	2.2	0.13	-	0	10	-	-10	140	FKM	398000 ₁	N74.4FV	WB4.5 230/50-60	4.5	-	1.3	064
	2.5	2.2	0.13	-	0	10	-	-10	140	FKM	398024 ₁	N74.4FV	WB4.5 24/50-60	4.5	-	1.3	064
	2.5	2.2	0.13	-	0	10	-	-10	140	FKM	398001 ₁	N74.4FV	WB4.5 240/50-60	4.5	-	1.3	064
2.5	2.2	0.13	-	0	-	4	-10	140	FKM	398052 ₁	N74.4FV	WB5.0 12DC	-	5	1.3	064	
2.5	2.2	0.13	-	0	-	4	-10	140	FKM	398022 ₁	N74.4FV	WB5.0 24DC	-	5	1.3	064	
2.5	3.3	0.20	-	0	10	-	-10	140	FKM	363380	PM146FV	ZB09	9	-	20.1/20.2	034	

Notes:

1. Ordering number is for an assembled valve and coil, with the voltage shown.



For this page	Port size	Orifice (mm)	Kv (l/min)	MOPD (bar)	Fluid Temp (°C)	Amb Temp (°C)
From	1/8"	1.2	0.7	4	-10	-10
To	1/8"	2.5	3.3	20	140	50

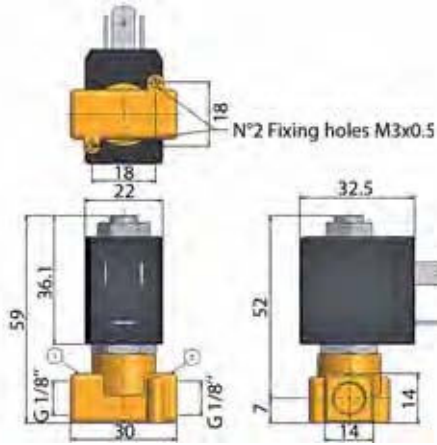

Drawing 064

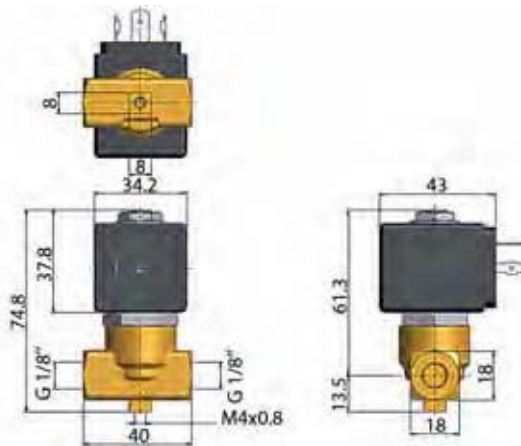

Drawing 034

2/2

VALVES FOR DRY OR LUBRICATED AIR, NEUTRAL
GASES AND LIQUIDS
DIRECT OPERATED

BRASS

PIPE MOUNTING

NORMALLY CLOSED

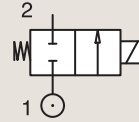

Port size	Orifice Ø	Flow factors			Operating Pressure Differential			Fluid Temp.		Seat Seal	Parker Valves			Power		Coil Group	Dwg. No.
		Kv l/min	KV m³/h	Qn m³/h	Min bar	Max(MOPD) bar	DC bar	Min °C	Max °C		Valve Order Number	Valve Type	Coil Type	AC W	DC W		
1/8"	2.5	3.3	0.20	-	0	-	5	-10	140	FKM	363380	PM146FV	ZB12	-	12	20.1/20.2	034
	3	4.5	0.27	-	0	7	-	-10	140	FKM	363390	PM146HV	ZB09	9	-	20.1/20.2	034
	3	4.5	0.27	-	0	-	2	-10	140	FKM	363390	PM146HV	ZB12	-	12	20.1/20.2	034
1/4"	2.5	2.2	0.13	-	0	10	-	-10	140	FKM	398006 ₁	N74.4WV	WB4.5 230/50-60	4.5	-	1.3	065
	2.5	2.2	0.13	-	0	10	-	-10	140	FKM	398007 ₁	N74.4WV	WB4.5 24/50-60	4.5	-	1.3	065
	2.5	2.2	0.13	-	0	-	4	-10	140	FKM	398008 ₁	N74.4WV	WB5.0 12DC	-	5	1.3	065
	2.5	2.2	0.13	-	0	-	4	-10	140	FKM	398010 ₁	N74.4WV	WB5.0 24DC	-	5	1.3	065
	2.5	2.2	0.13	-	0	19	-	-10	140	FKM	398012 ₁	N74.4WV	WB8.0 230/50-60	8	-	1.3	065
	3	4.5	0.27	-	0	7	-	-10	140	FKM	363444	PM146YV	ZB09	9	-	20.1/20.2	035
	3	4.5	0.27	-	0	-	2	-10	140	FKM	363444	PM146YV	ZB12	-	12	20.1/20.2	035
	4.5	9	0.53	-	0	6	-	-10	140	FKM	363457	PM146.3KV	ZB14	14	-	20.2	035
	4.5	9	0.53	-	0	-	2.5	-10	140	FKM	363457	PM146.3KV	ZB16	-	16	20.2	035
	6	13	0.75	-	0	6	-	-10	140	FKM	363467	PM146.3ABV	ZB14	14	-	20.2	035
6	13	0.75	-	0	-	1	-10	140	FKM	363467	PM146.3ABV	ZB16	-	16	20.2	035	

Notes:

1. Ordering number is for an assembled valve and coil, with the voltage shown.



For this page	Port size	Orifice (mm)	Kv (l/min)	MOPD (bar)	Fluid Temp (°C)	Amb Temp (°C)
From	1/8"	2.5	2.2	1	-10	-10
To	1/4"	6	13	19	140	50

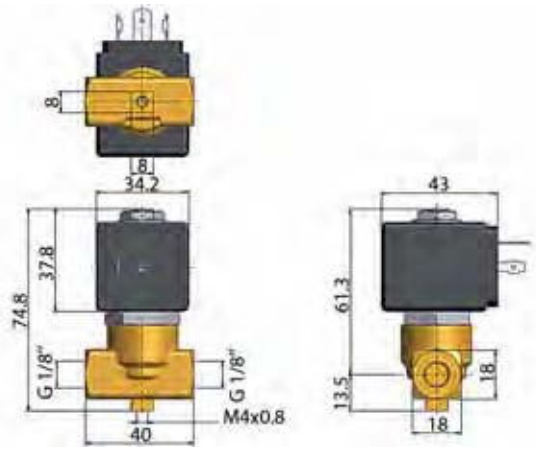

Drawing 034

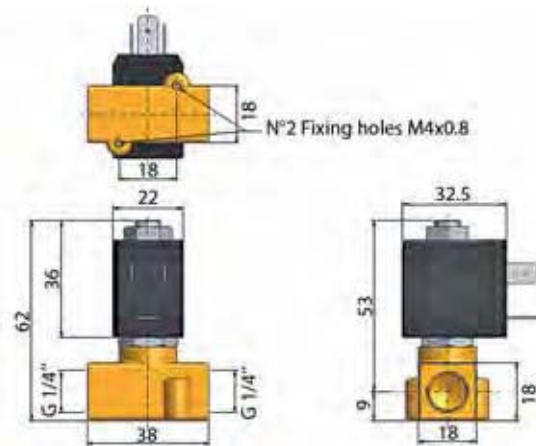

Drawing 065

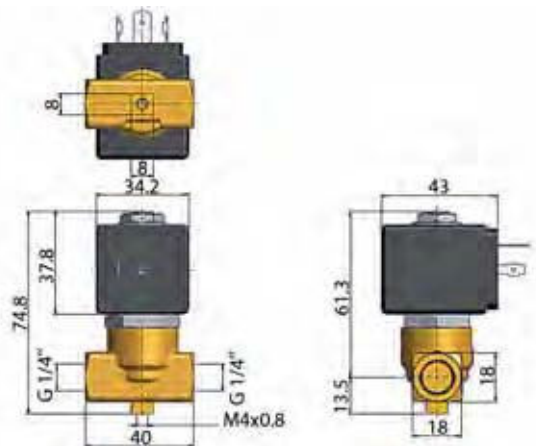

Drawing 035

2/2

VALVES FOR DRY OR LUBRICATED AIR, NEUTRAL GASES AND LIQUIDS DIRECT OPERATED

BRASS

PIPE MOUNTING

NORMALLY CLOSED

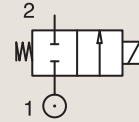

Port size	Orifice Ø	Flow factors			Operating Pressure Differential			Fluid Temp.		Seat Seal	Parker LUCIFER® Valves			IS	Power		Coil Group	Dwg. No.
		Kv l/min	KV m³/h	Qn l/min	Min bar	Max(MOPD) AC bar	DC bar	Min °C	Max °C		Valve Ref.	Housing Ref.	Coil Ref.		AC W	DC W		
1/8"	1.5	0.9	0.05	70	0	20	12	-10	75	FKM	121M14	8993	481180	4	5	1.1	3382	
	1.5	0.9	0.05	70	0	20	4	-10	75	FKM	121M14	8993	488980	2	2.5	1.1	3382	
	1.5	1.5	0.09	80	0	60	25	-30	75	PCTFE	E121K14	2995	481865	8	9	2.0	3510	
	1.5	1.5	0.09	80	0	70	30	-30	75	PCTFE	E121K14	4270	481000	8	8	2.0	3510	
	1.5	1.5	0.09	80	0	70	55	-30	75	PCTFE	E121K14	4270	486265	14	14	2.0	3510	
	2	2	0.12	125	0	10	7	-10	75	FKM	121M13	8993	481180	4	5	1.1	3382	
	2	2	0.12	125	0	10	2.5	-10	75	FKM	121M13	8993	488980	2	2.5	1.1	3382	
	2.5	3.5	0.21	220	0	28	10	-30	100	Ruby	E121K23	2995	481865	8	9	2.0	3510	
	2.5	3.5	0.21	220	0	34	12	-30	130	Ruby	E121K23	4270	481000	8	8	2.0	3510	
	2.5	3.5	0.21	220	0	50	22	-30	120	Ruby	E121K23	4270	486265	14	14	2.0	3510	
	3	4.5	0.27	320	0	10	7	-10	100	FKM	121K1302	2995	481865	8	9	2.0	3510	
	1/4"	3	4.5	0.27	320	0	10	8	-10	120	FKM	121K1302	4270	481000	8	8	2.0	3510
3		4.5	0.27	320	0	10	10	-10	120	FKM	121K1302	4270	486265	14	14	2.0	3510	
1.2		0.85	0.05	50	0	80	36	-30	100	Ruby	E121K65	2995	481865	8	9	2.0	3510	
1.2		0.85	0.05	50	0	100	43	-30	130	Ruby	E121K65	4270	481000	8	8	2.0	3510	
1.2		0.85	0.05	50	0	100	75	-30	120	Ruby	E121K65	4270	486265	14	14	2.0	3510	
1.5		1.5	0.09	80	0	-	8	-20	75	PUR	121K0497 ₁	2995	482740	-	1.6	6.0/8.0	8274	
1.5		1.5	0.09	80	0	10	10	-20	75	PUR	121K0497 ₁	-	495900	2.5	2	6.0/8.0	8274	
1.5		1.5	0.09	80	0	-	10	-20	75	PUR	121K0497 ₁	-	495910	* -	0.3 to 3	6.0/8.0	8274	
1.5		1.5	0.09	80	0	-	8	-20	75	PUR	121K0497 ₁	2995	496125	-	1.6	6.0/8.0	8274	
1.5		1.5	0.09	80	0	60	25	-30	75	PCTFE	E121K04	2995	481865	8	9	2.0	3510	
1.5		1.5	0.09	80	0	70	30	-30	75	PCTFE	E121K04	4270	481000	8	8	2.0	3510	
1.5		1.5	0.09	80	0	70	55	-30	75	PCTFE	E121K04	4270	486265	14	14	2.0	3510	
1.5		1.5	0.09	80	0	20	20	-10	100	FKM	E121K0402	2995	481865	8	9	2.0/3.0	3510	
1.5		1.5	0.09	80	0	20	20	-10	120	FKM	E121K0402	4270	481000	8	8	2.0/3.0	3510	
1.5		1.5	0.09	80	0	60	25	-30	100	Ruby	E121K67	2995	481865	8	9	2.0	3510	
1.5		1.5	0.09	80	0	75	30	-30	130	Ruby	E121K67	4270	481000	8	8	2.0	3510	
1.5		1.5	0.09	80	0	100	55	-30	120	Ruby	E121K67	4270	486265	14	14	2.0	3510	
2.5		3.5	0.21	220	0	14	7	-10	100	FKM	121K0706	2995	481865	8	9	2.0	3510	
2.5		3.5	0.21	220	0	14	9	-10	120	FKM	121K0706	4270	481000	8	8	2.0	3510	
2.5		3.5	0.21	220	0	14	14	-10	120	FKM	121K0706	4270	486265	14	14	2.0	3510	
2.5	3.5	0.21	220	0	28	10	-30	75	PCTFE	E121K07	2995	481865	8	9	2.0	3510		
2.5	3.5	0.21	220	0	34	12	-30	75	PCTFE	E121K07	4270	481000	8	8	2.0	3510		
2.5	3.5	0.21	220	0	50	22	-30	75	PCTFE	E121K07	4270	486265	14	14	2.0	3510		

Notes:

1. Valve compatible with water only up to 40°C



For this page	Port size	Orifice (mm)	Kv (l/min)	MOPD (bar)	Fluid Temp (°C)	Amb Temp (°C)
From	1/8"	1.2	0.9	2.5	-30	-20
To	1/4"	3	4.5	100	130	50

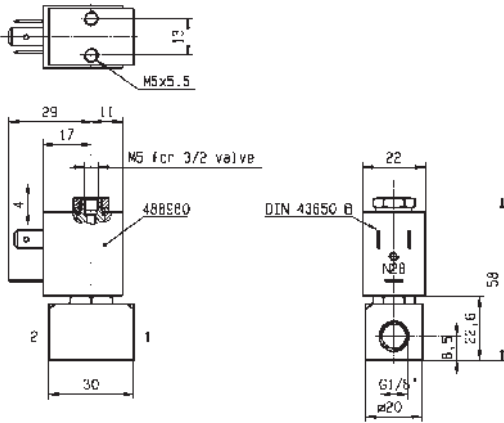

Drawing 3382

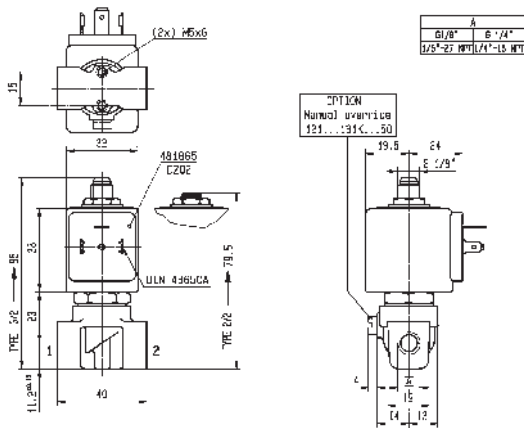

Drawing 3510

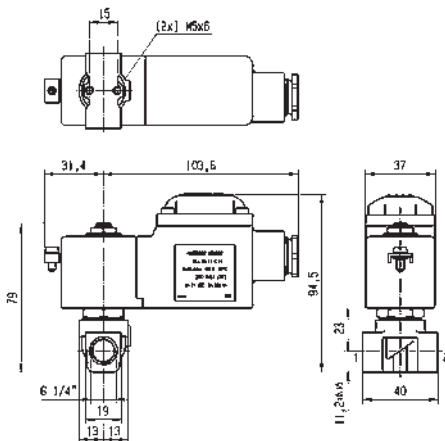

Drawing 8274

2/2

VALVES FOR DRY OR LUBRICATED AIR, NEUTRAL GASES AND LIQUIDS DIRECT OPERATED

BRASS

PIPE MOUNTING

NORMALLY CLOSED

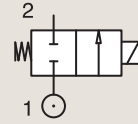

Port size	Orifice Ø	Flow factors			Operating Pressure Differential			Fluid Temp.		Seat Seal	Parker LUCIFER® Valves			IS	Power		Coil Group	Dwg. No.
		Kv l/min	KV m³/h	Qn l/min	Min bar	Max(MOPD) AC bar	DC bar	Min °C	Max °C		Valve Ref.	Housing Ref.	Coil Ref.		AC W	DC W		
1/4"	2.5	3.5	0.21	220	0	28	10	-30	100	Ruby	E121K63	2995	481865		8	9	2.0	3510
	2.5	3.5	0.21	220	0	34	12	-30	130	Ruby	E121K63	4270	481000		8	8	2.0	3510
	2.5	3.5	0.21	220	0	50	22	-30	120	Ruby	E121K63	4270	486265		14	14	2.0	3510
	3	3.5	0.21	250	0	-	2	-20	75	PUR	121K0397 ₁	2995	482740		-	1.6	6.0/8.0	8074
	3	3.5	0.21	250	0	4.5	4	-20	75	PUR	121K0397 ₁	-	495900		2.5	2	6.0/8.0	8074
	3	3.5	0.21	250	0	-	4.5	-20	75	PUR	121K0397 ₁	-	495910	*	-	0.3 to 3	6.0/8.0	8074
	3	3.5	0.21	250	0	-	2	-20	75	PUR	121K0397 ₁	2995	496125		-	1.6	6.0/8.0	8274
	3	4.5	0.27	320	0	20	7	-30	75	PCTFE	E121K03	2995	481865		8	9	2.0/3.0	3510
	3	4.5	0.27	320	0	25	8.5	-30	75	PCTFE	E121K03	4270	481000		8	8	2.0/3.0	3510
	3	4.5	0.27	320	0	36	15	-30	75	PCTFE	E121K03	4270	486265		14	14	2.0/3.0	3510
	3	4.5	0.27	320	0	10	7	-10	100	FKM	E121K0302	2995	481865		8	9	2.0	3510
	3	4.5	0.27	320	0	10	8.5	-10	120	FKM	E121K0302	4270	481000		8	8	2.0	3510
	3	4.5	0.27	320	0	10	7	-10	100	FKM	E121K0302	4270	486265		14	14	2.0	3510
	3	4.5	0.27	320	0	10	7	-10	100	FKM	E121K0352 ₂	2995	481865		8	9	2.0	3510
	3	4.5	0.27	320	0	10	8.5	-10	120	FKM	E121K0352 ₂	4270	481000		8	8	2.0	3510
	3	4.5	0.27	320	0	10	10	-10	120	FKM	E121K0352 ₂	4270	486265		14	14	2.0	3510
	3	4.5	0.27	320	0	20	7	-30	100	Ruby	E121K64	2995	481865		8	9	2.0	3510
	3	4.5	0.27	320	0	25	8.5	-30	130	Ruby	E121K64	4270	481000		8	8	2.0	3510
	3	4.5	0.27	320	0	36	15	-30	120	Ruby	E121K64	4270	486265		14	14	2.0	3510
	4	7.5	0.45	480	0	10	4	-10	100	FKM	121K02	2995	481865		8	9	2.0	3510
	4	7.5	0.45	480	0	10	5	-10	120	FKM	121K02	4270	481000		8	8	2.0	3510
	4	7.5	0.45	480	0	10	10	-10	120	FKM	121K02	4270	486265		14	14	2.0	3510
	4	7.5	0.45	480	0	10	4	-10	100	FKM	121K0250 ₂	2995	481865		8	9	2.0	3510
	4	7.5	0.45	480	0	10	5	-10	120	FKM	121K0250 ₂	4270	481000		8	8	2.0	3510
	4	7.5	0.45	480	0	10	10	-10	120	FKM	121K0250 ₂	4270	486265		14	14	2.0	3510
	5	11	0.66	750	0	7	2	-10	100	FKM	121K01	2995	481865		8	9	2.0/14.2	3510
	5	11	0.66	750	0	7	2.8	-10	120	FKM	121K01	4270	481000		8	8	2.0/14.2	3510
	5	11	0.66	750	0	7	5	-10	120	FKM	121K01	4270	486265		14	14	2.0/14.2	3510
	5	11	0.66	750	0	7	2	-10	100	FKM	121K0106	2995	481865		8	9	2.0	3510
	5	11	0.66	750	0	7	2.8	-10	120	FKM	121K0106	4270	481000		8	8	2.0	3510
	5	11	0.66	750	0	7	5	-10	120	FKM	121K0106	4270	486265		14	14	2.0	3510
	5	11	0.66	750	0	7	2	-10	100	FKM	121K0150 ₂	2995	481865		8	9	2.0	3510
5	11	0.66	750	0	7	2.8	-10	120	FKM	121K0150 ₂	4270	481000		8	8	2.0	3510	
5	11	0.66	750	0	7	5	-10	120	FKM	121K0150 ₂	4270	486265		14	14	2.0	3510	

Notes:

- 1. Valve compatible with water only up to 40°C
- 2. With manual override



For this page	Port size	Orifice (mm)	Kv (l/min)	MOPD (bar)	Fluid Temp (°C)	Amb Temp (°C)
From	1/4"	2.5	3.5	2	-30	-20
To	1/4"	5	11	50	130	50

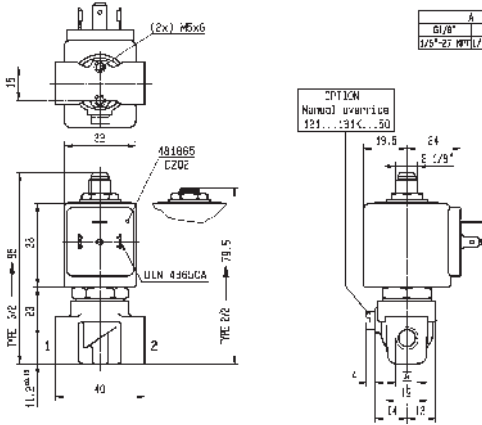

Drawing 3510

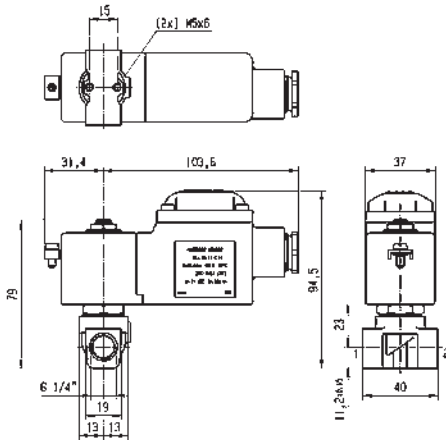

Drawing 8274

2/2

VALVES FOR DRY OR LUBRICATED AIR, NEUTRAL
GASES AND LIQUIDS
DIRECT OPERATED

BRASS

PIPE MOUNTING

NORMALLY CLOSED

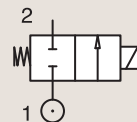

Port size	Orifice Ø	Flow factors			Operating Pressure Differential			Fluid Temp.		Seat Seal	Parker LUCIFER® Valves			Power		Coil Group	Dwg. No.
		Kv	KV	Qn	Min	Max(MOPD)	Min	Max	Valve Ref.		Housing Ref.	Coil Ref.	AC W	DC W			
BSP	mm	l/min	m³/h	l/min	bar	AC bar	DC bar	°C	°C								
3/8"	4	7.5	0.45	480	0	10	4	-10	100	FKM	121K3206	2995	481865	8	9	2.0	3551
	4	7.5	0.45	480	0	10	5	-10	120	FKM	121K3206	4270	481000	8	8	2.0	3551
	4	7.5	0.45	480	0	10	10	-10	120	FKM	121K3206	4270	486265	14	14	2.0	3551
	5	11	0.66	750	0	7	2	-10	100	FKM	121K3106	2995	481865	8	9	2.0	3551
	5	11	0.66	750	0	7	2.8	-10	120	FKM	121K3106	4270	481000	8	8	2.0	3551
	5	11	0.66	750	0	7	5	-10	120	FKM	121K3106	4270	486265	14	14	2.0	3551
	6	12	0.72	1100	0	5	1.1	-10	100	FKM	121K3306	2995	481865	8	9	2.0/14.2	3551
	6	12	0.72	1100	0	5	1.5	-10	120	FKM	121K3306	4270	481000	8	8	2.0/14.2	3551
1/2"	6	12	0.72	1100	0	5	3	-10	120	FKM	121K3306	4270	486265	14	14	2.0/14.2	3551
	8.5	25	1.5	1600	0	1.1	0.5	-10	100	FKM	E121K46	2995	481865	8	9	2.0	3427
	8.5	25	1.5	1600	0	2.2	0.5	-10	120	FKM	E121K46	4270	481000	8	8	2.0	3427
	8.5	25	1.5	1600	0	4	1.2	-10	120	FKM	E121K46	4270	486265	14	14	2.0	3427
	11	36	2.16	2500	0	0.7	0.3	-10	100	FKM	E121K45	2995	481865	8	9	2.0	3427
	11	36	2.16	2500	0	1.2	0.35	-10	120	FKM	E121K45	4270	481000	8	8	2.0	3427
	11	36	2.16	2500	0	2.5	0.7	-10	120	FKM	E121K45	4270	486265	14	14	2.0	3427



For this page	Port size	Orifice (mm)	Kv (l/min)	MOPD (bar)	Fluid Temp (°C)	Amb Temp (°C)
From	3/8"	4	7.5	0.3	-10	-10
To	1/2"	11	36	10	120	50

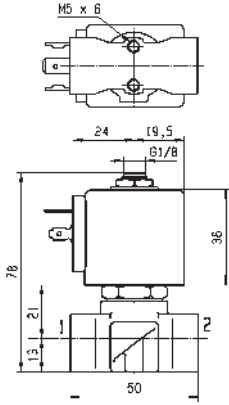

MCI611T : 215 gr

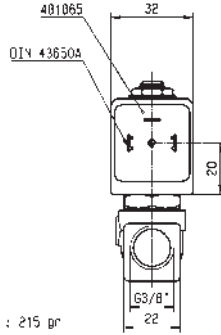

Drawing 3551

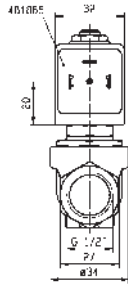
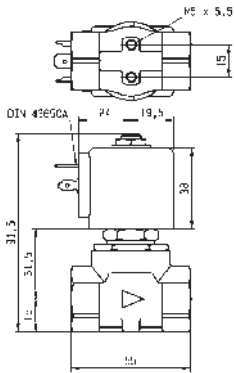

Drawing 3427

2/2

VALVES FOR DRY OR LUBRICATED AIR, NEUTRAL
GASES AND LIQUIDS
DIRECT OPERATED

BRASS

PIPE MOUNTING

NORMALLY OPEN

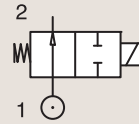

Port size	Orifice Ø	Flow factors			Operating Pressure Differential			Fluid Temp.		Seat Seal	Parker Valves			Power		Coil Group	Dwg. No.	
		Kv l/min	KV m³/h	Qn m³/h	Min bar	Max(MOPD) AC bar	DC bar	Min °C	Max °C		Valve Order Number	Valve Type	Coil Type	AC W	DC W			
1/4"	BSP	1.5	1.3	0.08	-	0	22	-	-10	140	FKM	363745	PM151GV	ZB09	9	-	20.1/20.2	036
		1.5	1.3	0.08	-	0	-	22	-10	140	FKM	363745	PM151GV	ZB12	-	12	20.1/20.2	036
		2	1.8	0.11	-	0	18	-	-10	140	FKM	362290	PM136.2FV	ZB14	14	-	20.2	020
		2	1.8	0.11	-	0	-	18	-10	140	FKM	362290	PM136.2FV	ZB16	-	16	20.2	020
		2	2.5	0.15	-	0	12	-	-10	140	FKM	363570	PM151HV	ZB09	9	-	20.1/20.2	036
		2	2.5	0.15	-	0	-	12	-10	140	FKM	363570	PM151HV	ZB12	-	12	20.1/20.2	036
		3	4	0.24	-	0	5.5	-	-10	140	FKM	362286	PM136VV	ZB14	14	-	20.2	020
		3	4	0.24	-	0	-	5.5	-10	140	FKM	362286	PM136VV	ZB16	-	16	20.2	020



For this page	Port size	Orifice (mm)	Kv (l/min)	MOPD (bar)	Fluid Temp (°C)	Amb Temp (°C)
From	1/4"	1.5	1.3	5.5	-10	-10
To	1/4"	3	4	22	140	50

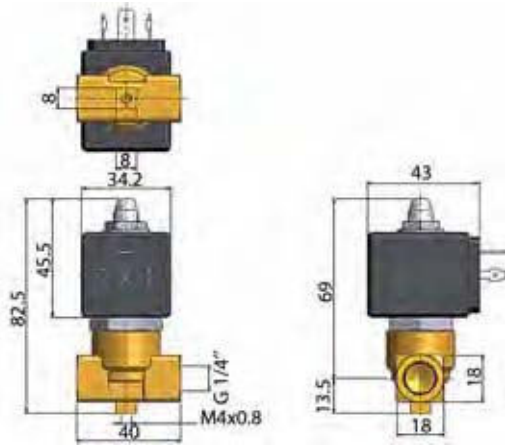

Drawing 036

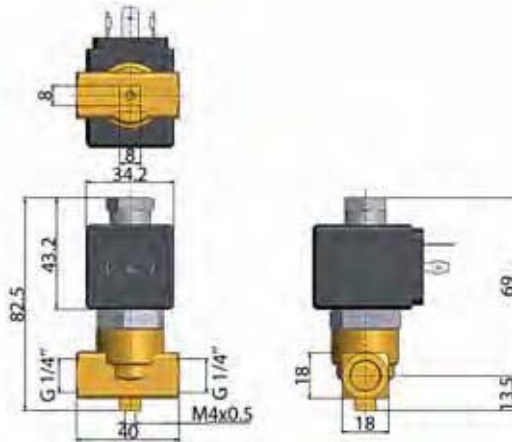

Drawing 020

2/2

VALVES FOR DRY OR LUBRICATED AIR, NEUTRAL GASES AND LIQUIDS DIRECT OPERATED

BRASS

PIPE MOUNTING

NORMALLY OPEN

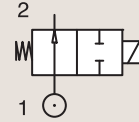

Port size	Orifice Ø	Flow factors			Operating Pressure Differential			Fluid Temp.		Seat Seal	Parker LUCIFER® Valves			Power		Coil Group	Dwg. No.
											Valve Ref.	Housing Ref.	Coil Ref.	AC W	DC W		
BSP	mm	Kv l/min	KV m³/h	Qn l/min	bar	AC bar	DC bar	°C	°C								
1/8"	2.5	3.5	0.21	-	0	30	-	-30	140	Ruby	122K9363	4270	481044	14	-	2.2	3510
	2.5	3.5	0.21	-	0	30	30	-30	140	Ruby	122K9363	4270	486265	14	14	2.2	3510
1/4"	1.5	1.5	0.09	9.6	0	30	30	-10	100	PCTFE	122K84	2995	481865	8	9	2.0	3510
	1.5	1.5	0.09	9.6	0	30	30	-10	100	PCTFE	122K84	4270	481000	8	8	2.0	3510
	1.5	1.5	0.09	9.6	0	30	30	-10	120	PCTFE	122K84	4270	486265	14	14	2.0	3510
	1.5	1.5	0.09	80	0	20	20	-10	100	FKM	122K8406	2995	481865	8	9	2.1	3510
	1.5	1.5	0.09	80	0	20	20	-10	120	FKM	122K8406	4270	481000	8	8	2.1	3510
	1.5	1.5	0.09	80	0	40	40	-30	100	Ruby	122K8408	2995	481865	8	9	2.1	3510
	1.5	1.5	0.09	80	0	40	40	-30	130	Ruby	122K8408	4270	481000	8	8	2.1	3510
	1.5	1.5	0.09	80	0	40	40	-30	130	Ruby	122K8408	4270	486265	14	14	2.0	3510
	2.5	3	0.18	180	0	12	12	-30	75	PCTFE	122K83	2995	481865	8	9	2.1	3510
	2.5	3	0.18	180	0	12	12	-30	75	PCTFE	122K83	4270	481000	8	8	2.1	3510
	2.5	3	0.18	180	0	12	12	-30	75	PCTFE	122K83	4270	486265	14	14	2.0	3510
	2.5	3	0.18	180	0	12	12	-10	100	FKM	122K8306	2995	481865	8	9	2.0	3510
	2.5	3	0.18	180	0	12	12	-10	120	FKM	122K8306	4270	481000	8	8	2.0	3510
	2.5	3	0.18	180	0	12	12	-10	120	FKM	122K8306	4270	486265	14	14	2.0	3510
	2.5	3.5	0.21	-	0	30	-	-30	140	Ruby	122K8363	4270	481044	14	-	2.2	3510
	2.5	3.5	0.21	-	0	30	30	-30	140	Ruby	122K8363	4270	486265	14	14	2.2	3510

BRASS

PIPE MOUNTING

CONTROL BY ELECTRIC IMPULSE

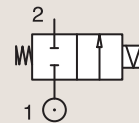

Port size	Orifice Ø	Flow factors			Operating Pressure Differential			Fluid Temp.		Seat Seal	Parker LUCIFER® Valves			Power		Coil Group	Dwg. No.
											Valve Ref.	Housing Ref.	Coil Ref.	AC W	DC W		
BSP	mm	Kv l/min	KV m³/h	Qn l/min	bar	AC bar	DC bar	°C	°C								
1/4"	3	4.5	0.27	320	0	20	-	-30	75	PCTFE	125K03	4269	484990	11	-	4.0	8296
	3	4.5	0.27	320	0	-	7	-30	75	PCTFE	125K03	4269	485400	-	13	4.0	8296
	5	11	0.66	750	0	5	-	-10	100	FKM	125K01	4269	484990	11	-	4.0	8296
	5	11	0.66	750	0	-	1.5	-10	100	FKM	125K01	4269	485400	-	13	4.0	8296



For this page	Port size	Orifice (mm)	Kv (l/min)	MOPD (bar)	Fluid Temp (°C)	Amb Temp (°C)
From	1/8"	1.5	1.5	1.5	-30	-10
To	1/4"	5	11	40	140	50

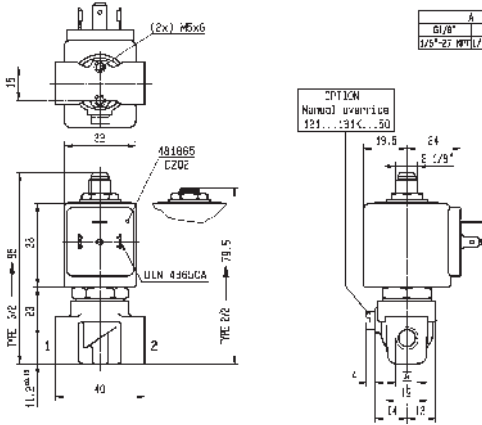

Drawing 3510

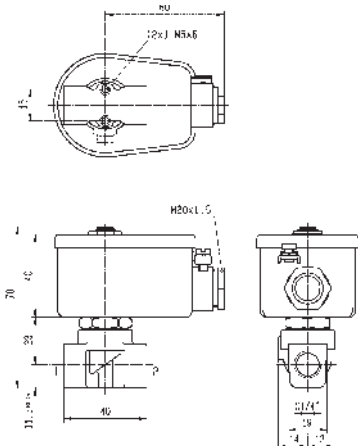

Drawing 8296

2/2

VALVES FOR DRY OR LUBRICATED AIR, NEUTRAL
GASES AND LIQUIDS
DIRECT OPERATED

BRASS

SUB-BASE MOUNTING

NORMALLY CLOSED

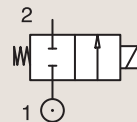

Port size	Orifice Ø mm	Flow factors			Operating Pressure Differential Max(MOPD)			Fluid Temp.		Seat Seal	Parker LUCIFER® Valves			Power		Coil Group	Dwg. No.
		Kv l/min	KV m³/h	Qn l/min	Min bar	AC bar	DC bar	Min °C	Max °C		Valve Ref.	Housing Ref.	Coil Ref.	AC W	DC W		
SB	1.5	1.5	0.09	80	0	20	-	-10	100	EPDM	121F4417	2995	483510	9	-	2.0	3509
	1.5	1.5	0.09	80	0	60	25	-30	100	Ruby	121F67	2995	481865	8	9	2.0	3509
	1.5	1.5	0.09	80	0	75	30	-30	130	Ruby	121F67	4270	481000	8	8	2.0	3509
	1.5	1.5	0.09	80	0	100	55	-30	120	Ruby	121F67	4270	486265	14	14	2.0	3509
	1.5	1.5	0.09	80	0	60	25	-30	75	PCTFE	E121F44	2995	481865	8	9	2.0	3509
	1.5	1.5	0.09	80	0	70	30	-30	75	PCTFE	E121F44	4270	481000	8	8	2.0	3509
	1.5	1.5	0.09	80	0	70	55	-30	75	PCTFE	E121F44	4270	486265	14	14	2.0	3509
	1.5	1.5	0.09	80	0	20	20	-10	100	FKM	E121F4406	2995	481865	8	9	2.0	3509
	1.5	1.5	0.09	80	0	20	20	-10	120	FKM	E121F4406	4270	481000	8	8	2.0	3509
	1.5	1.5	0.09	80	0	20	20	-10	120	FKM	E121F4406	4270	486265	14	14	2.0	3509
	2.5	3.5	0.21	220	0	28	10	-30	75	PCTFE	121F47	2995	481865	8	9	2.0	3509
	2.5	3.5	0.21	220	0	34	12	-30	75	PCTFE	121F47	4270	481000	8	8	2.0	3509
	2.5	3.5	0.21	220	0	50	22	-30	75	PCTFE	121F47	4270	486265	14	14	2.0	3509
	2.5	3.5	0.21	220	0	14	7	-10	100	FKM	121F4706	2995	481865	8	9	2.0	3509
	2.5	3.5	0.21	220	0	14	9	-10	120	FKM	121F4706	4270	481000	8	8	2.0	3509
	2.5	3.5	0.21	220	0	14	14	-10	120	FKM	121F4706	4270	486265	14	14	2.0	3509
	2.5	3.5	0.21	220	0	28	10	-30	100	Ruby	121F63	2995	481865	8	9	2.0	3509
	2.5	3.5	0.21	220	0	34	12	-30	130	Ruby	121F63	4270	481000	8	8	2.0	3509
	2.5	3.5	0.21	220	0	50	22	-30	120	Ruby	121F63	4270	486265	14	14	2.0	3509
	3	4.5	0.27	320	0	10	-	-10	100	FKM	121F4317	2995	483510	9	-	2.0	3509
	3	4.5	0.27	320	0	20	7	-30	100	Ruby	121F64	2995	481865	8	9	2.0	3509
	3	4.5	0.27	320	0	25	8.5	-30	130	Ruby	121F64	4270	481000	8	8	2.0	3509
	3	4.5	0.27	320	0	36	15	-30	120	Ruby	121F64	4270	486265	14	14	2.0	3509
	3	4.5	0.27	320	0	20	7	-30	75	PCTFE	E121F43	2995	481865	8	9	2.0	3509
	3	4.5	0.27	320	0	25	8.5	-30	75	PCTFE	E121F43	4270	481000	8	8	2.0	3509
	3	4.5	0.27	320	0	36	15	-30	75	PCTFE	E121F43	4270	486265	14	14	2.0	3509
	3	4.5	0.27	320	0	10	7	-10	100	FKM	E121F4302	2995	481865	8	9	2.0/3.0	3509
	3	4.5	0.27	320	0	10	8.5	-10	120	FKM	E121F4302	4270	481000	8	8	2.0/3.0	3509
	3	4.5	0.27	320	0	10	10	-10	120	FKM	E121F4302	4270	486265	14	14	2.0/3.0	3509

2 WAY VALVES



For this page	Port size	Orifice (mm)	Kv (l/min)	MOPD (bar)	Fluid Temp (°C)	Amb Temp (°C)
From	5 mm	1.5	1.5	7	-30	-10
To	5 mm	3	4.5	100	130	50

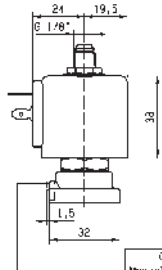
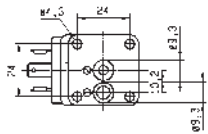

CPTICK
Modelo de válvula
121...131F...50

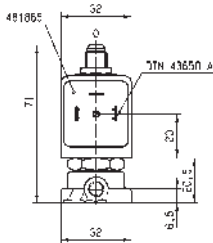

Drawing 3509

2/2

VALVES FOR DRY OR LUBRICATED AIR, NEUTRAL GASES AND LIQUIDS
DIRECT OPERATED

BRASS

SUB-BASE MOUNTING

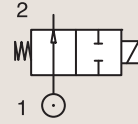

NORMALLY OPEN

Port size	Orifice Ø			Flow factors			Operating Pressure Differential			Fluid Temp.		Seat Seal	Parker LUCIFER® Valves			Power		Coil Group	Dwg. No.
							Min	Max(MOPD)		Min	Max		Valve Ref.	Housing Ref.	Coil Ref.	AC W	DC W		
	bar	AC bar	DC bar	°C	°C														
SB	1.5	1.5	0.09	80	0	20	20	-10	100	FKM	122F44	2995	481865	8	9	2.1	3509		
	1.5	1.5	0.09	80	0	20	20	-10	120	FKM	122F44	4270	481000	8	8	2.1	3509		



For this page	Port size	Orifice (mm)	Kv (l/min)	MOPD (bar)	Fluid Temp (°C)	Amb Temp (°C)
From	5 mm	1.5	1.5	20	-10	-10
To	5 mm	1.5	1.5	20	120	50

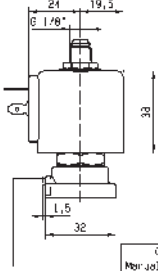
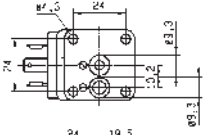

OPTICA
Módulo de válvula
21...131F...50

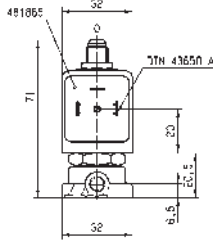

Drawing 3509

2/2

VALVES FOR DRY OR LUBRICATED AIR, NEUTRAL GASES AND LIQUIDS
MAGNALIFT



Commercial Equipment



Industrial Equipment

BRASS PIPE MOUNTING

NORMALLY CLOSED

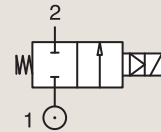

Port size	Orifice Ø mm	Flow factors			Operating Pressure Differential			Fluid Temp.		Seat Seal	Parker Valves			Power		Coil Group	Dwg. No.
		Kv l/min	KV m³/h	Qn m³/h	Min bar	Max(MOPD) AC bar	DC bar	Min °C	Max °C		Valve Order Number	Valve Type	Coil Type	AC W	DC W		
3/8"	13	40	2.4	-	0	5	-	-10	140	FKM	361810	PM123IV	ZB09	9	-	20.1	004
1/2"	13	40	2.4	-	0	5	-	-10	140	FKM	361850	PM123AV	ZB09	9	-	20.1	003
3/4"	20	100	6	-	0	3	-	-10	140	FKM	361910	PM123CV	JB14	14	-	21.0	005
1"	25	117	7	-	0	3	-	-10	140	FKM	361950	PM123DV	JB14	14	-	21.0	006



For this page	Port size	Orifice (mm)	Kv (l/min)	MOPD (bar)	Fluid Temp (°C)	Amb Temp (°C)
From	3/8"	13	40	3	-10	-10
To	1"	25	117	5	140	50

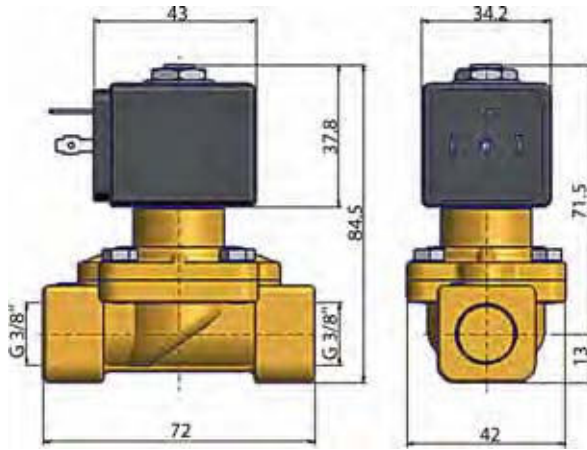

Drawing 004

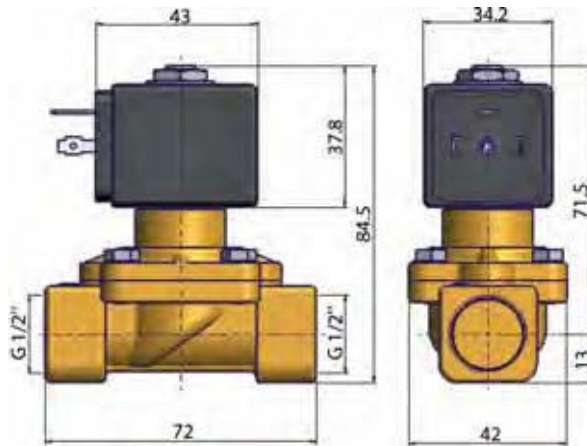

Drawing 003

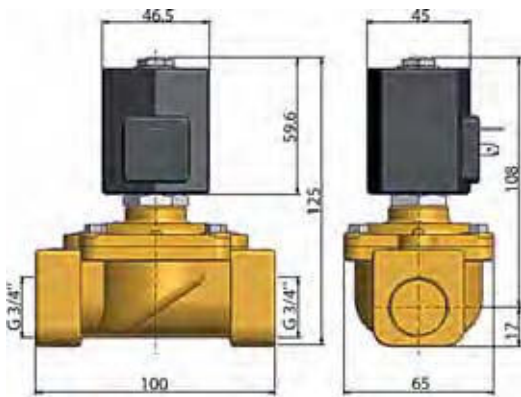

Drawing 005

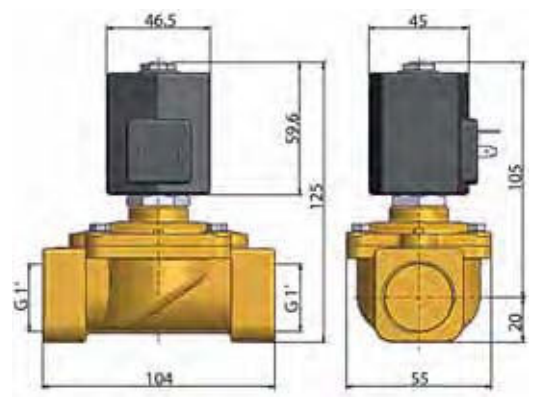

Drawing 006

2/2

VALVES FOR DRY OR LUBRICATED AIR, NEUTRAL GASES AND LIQUIDS
MAGNALIFT

BRASS

PIPE MOUNTING

NORMALLY CLOSED

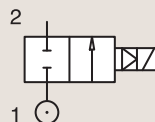

Port size	Orifice Ø	Flow factors			Operating Pressure Differential			Fluid Temp.		Seat Seal	Parker LUCIFER® Valves			Power		Coil Group	Dwg. No.
		Kv l/min	KV m³/h	Qn l/min	Min bar	Max(MOPD) AC bar	DC bar	Min °C	Max °C		Valve Ref.	Housing Ref.	Coil Ref.	AC W	DC W		
3/8"	15	65	3.9	4500	0	16	-	-10	100	NBR	221G13	2995	481865	8	-	2.0	3732
	15	65	3.9	4500	0	16	-	-10	100	NBR	221G13	4270	481000	8	-	2.0	3732
	15	65	3.9	4500	0	16	7	-10	100	NBR	221G13	4270	486265	14	14	2.0	3732
	15	65	3.9	4500	0	16	-	0	100	FKM	221G23 ₁	2995	481865	8	-	2.0	3732
	15	65	3.9	4500	0	16	-	0	120	FKM	221G23 ₁	4270	481000	8	-	2.0	3732
	15	65	3.9	4500	0	20	7	0	140	FKM	221G23 ₁	4270	486265	14	14	2.0	3732
	15	65	3.9	4500	0	-	10	-10	100	FKM	221G2330 ₁₂	2995	481865	-	9	2.1	3732
	15	65	3.9	4500	0	10	10	-10	100	FKM	221G2330 ₁₂	-	492070	9	8	2.1	3732
	15	65	3.9	4500	0	10	10	-10	100	FKM	221G2330 ₁₂	-	492190	11	9	2.1	3732
1/2"	15	65	3.9	4500	0	16	-	-10	100	NBR	221G15	2995	481865	8	-	2.0	3732
	15	65	3.9	4500	0	16	-	-10	100	NBR	221G15	4270	481000	8	-	2.0	3732
	15	65	3.9	4500	0	16	7	-10	100	NBR	221G15	4270	486265	14	14	2.0	3732
	15	65	3.9	4500	0	-	10	-10	100	NBR	221G1530 ₂₃	2995	481865	-	9	2.1	3732
	15	65	3.9	4500	0	10	10	-10	120	NBR	221G1530 ₂₃	-	492070	9	8	2.1	3732
	15	65	3.9	4500	0	10	10	-10	120	NBR	221G1530 ₂₃	-	492190	11	9	2.1	3732
	15	65	3.9	4500	0	16	-	0	100	FKM	221G25 ₁	2995	481865	8	-	2.0	3732
	15	65	3.9	4500	0	16	-	0	120	FKM	221G25 ₁	4270	481000	8	-	2.0	3732
	15	65	3.9	4500	0	20	7	0	140	FKM	221G25 ₁	4270	486265	14	14	2.0	3732
	15	65	3.9	4500	0	-	10	-10	100	FKM	221G2530 ₁₂	2995	481865	-	9	2.1	3732
	15	65	3.9	4500	0	10	10	-10	100	FKM	221G2530 ₁₂	-	492070	9	8	2.1	3732
	15	65	3.9	4500	0	10	10	-10	100	FKM	221G2530 ₁₂	-	492190	11	9	2.1	3732

Notes:

1. Valve only compatible with hydraulic oil and air/neutral gases
2. Valves with model number ending in 30 or 31 are only compatible with explosion proof electrical parts shown, or with group 2.1 coils only in DC voltage.
3. Pilot seat in FKM



For this page	Port size	Orifice (mm)	Kv (l/min)	MOPD (bar)	Fluid Temp (°C)	Amb Temp (°C)
From	3/8"	15	65	7	-10	-10
To	1/2"	15	65	20	140	50

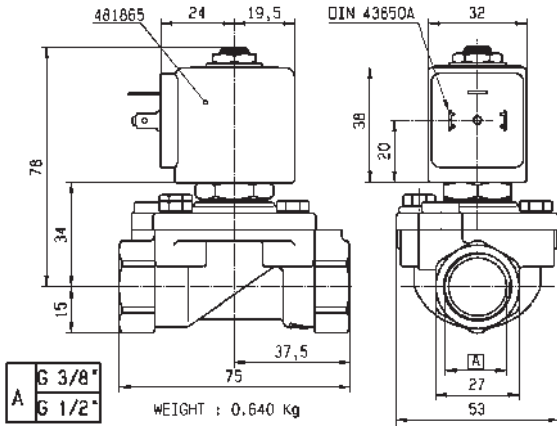

Drawing 3732

2/2

VALVES FOR DRY OR LUBRICATED AIR, NEUTRAL
GASES AND LIQUIDS
MAGNALIFT

BRASS

PIPE MOUNTING

NORMALLY CLOSED

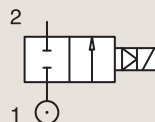

Port size	Orifice Ø	Flow factors			Operating Pressure Differential			Fluid Temp.		Seat Seal	Parker LUCIFER® Valves			Power		Coil Group	Dwg. No.
		Kv l/min	KV m³/h	Qn l/min	Min bar	Max(MOPD) AC bar	DC bar	Min °C	Max °C		Valve Ref.	Housing Ref.	Coil Ref.	AC W	DC W		
3/4"	15	80	4.8	6000	0	16	-	-10	100	NBR	221G16 ₄	2995	481865	8	-	2.0	3444
	15	80	4.8	6000	0	16	-	-10	100	NBR	221G16 ₄	4270	481000	8	-	2.0	3444
	15	80	4.8	6000	0	7	7	-10	100	NBR	221G16 ₄	4270	486265	14	14	2.0	3444
	15	80	4.8	6000	0	16	-	-10	100	NBR	221G1610 ₃	2995	481865	8	-	2.0	3444
	15	80	4.8	6000	0	16	-	-10	100	NBR	221G1610 ₃	4270	481000	8	-	2.0	3444
	15	80	4.8	6000	0	16	7	-10	100	NBR	221G1610 ₃	4270	486265	14	14	2.0	3444
	15	80	4.8	6000	0	10	10	-10	100	NBR	221G1630 ₂₄	2995	481865	8	9	2.1	3444
	15	80	4.8	6000	0	10	10	-25	40	NBR	221G1630 ₂₄	-	492070	9	8	2.1	3444
	15	80	4.8	6000	0	10	10	-25	40	NBR	221G1630 ₂₄	-	492190	11	9	2.1	3444
	15	80	4.8	6000	0	10	10	-10	100	NBR	221G1631 ₂₃₄	2995	481865	8	9	2.1	3444
	15	80	4.8	6000	0	10	10	-25	40	NBR	221G1631 ₂₃₄	-	492070	9	8	2.1	3444
	15	80	4.8	6000	0	10	10	-25	40	NBR	221G1631 ₂₃₄	-	492190	11	9	2.1	3444
	15	80	4.8	6000	0	16	-	0	100	FKM	221G26 ₁	2995	481865	8	-	2.0	3444
	15	80	4.8	6000	0	16	-	0	120	FKM	221G26 ₁	4270	481000	8	-	2.0	3444
	15	80	4.8	6000	0	20	7	0	140	FKM	221G26 ₁	4270	486265	14	14	2.0	3444
	15	80	4.8	6000	0	-	10	-10	100	FKM	221G2630 ₁₂	2995	481865	-	9	2.1	3444
	15	80	4.8	6000	0	10	10	-25	40	FKM	221G2630 ₁₂	-	492070	9	8	2.1	3444
	15	80	4.8	6000	0	10	10	-25	40	FKM	221G2630 ₁₂	-	492190	11	9	2.1	3444

Notes:

1. Valve only compatible with hydraulic oil and air/neutral gases
2. Valves with model number ending in 30 or 31 are only compatible with explosion proof electrical parts shown, or with group 2.1 coils only in DC voltage.
3. With 4 position selector for controlled closure rate
4. Pilot seat in FKM



For this page	Port size	Orifice (mm)	Kv (l/min)	MOPD (bar)	Fluid Temp (°C)	Amb Temp (°C)
From	3/4"	15	80	7	-25	-10
To	3/4"	15	80	20	140	50

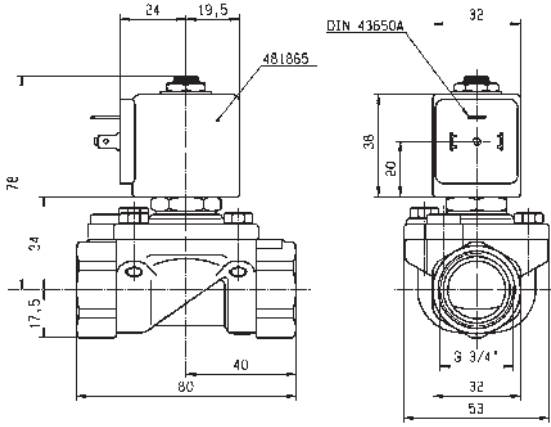

Drawing 3444

2/2

VALVES FOR DRY OR LUBRICATED AIR, NEUTRAL GASES AND LIQUIDS
MAGNALIFT

BRASS

PIPE MOUNTING

NORMALLY CLOSED

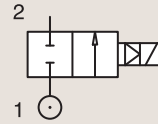

Port size	Orifice Ø	Flow factors			Operating Pressure Differential			Fluid Temp.		Seat Seal	Parker LUCIFER® Valves			Power		Coil Group	Dwg. No.
		Kv l/min	KV m³/h	Qn l/min	Min bar	Max(MOPD) AC bar	DC bar	Min °C	Max °C		Valve Ref.	Housing Ref.	Coil Ref.	AC W	DC W		
1"	15	80	4.8	6000	0	16	-	-10	100	NBR	221G17	2995	481865	8	-	2.0	3445
	15	80	4.8	6000	0	16	1	-10	100	NBR	221G17	4270	481000	8	8	2.0	3445
	15	80	4.8	6000	0	16	7	-10	100	NBR	221G17	4270	486265	14	14	2.0	3445
	15	80	4.8	6000	0	16	-	-10	100	NBR	221G1710 ₃	2995	481865	8	-	2.0	3445
	15	80	4.8	6000	0	16	-	-10	100	NBR	221G1710 ₃	4270	481000	8	-	2.0	3445
	15	80	4.8	6000	0	16	7	-10	100	NBR	221G1710 ₃	4270	486265	14	14	2.0	3445
	15	80	4.8	6000	0	10	10	-10	100	NBR	221G1730 ₁₂₄	2995	481865	8	9	2.1	3445
	15	80	4.8	6000	0	10	10	-10	120	NBR	221G1730 ₁₂₄	-	492070	9	8	2.1	3445
	15	80	4.8	6000	0	10	10	-10	120	NBR	221G1730 ₁₂₄	-	492190	11	9	2.1	3445
	15	80	4.8	6000	0	16	-	0	100	FKM	221G27 ₁	2995	481865	8	-	2.0	3445
	15	80	4.8	6000	0	16	-	0	120	FKM	221G27 ₁	4270	481000	8	-	2.0	3445
	15	80	4.8	6000	0	20	7	0	120	FKM	221G27 ₁	4270	486265	14	14	2.0	3445
	15	80	4.8	6000	0	-	10	0	100	FKM	221G2730 ₁₂	2995	481865	-	9	2.1	3445
	15	80	4.8	6000	0	10	10	-10	65	FKM	221G2730 ₁₂	-	492070	9	8	2.1	3445
	15	80	4.8	6000	0	10	10	-10	75	FKM	221G2730 ₁₂	-	492190	11	9	2.1	3445
	25	170	10.2	14000	0	16	-	-10	100	NBR	221G21	2995	481865	8	-	2.0	3448
	25	170	10.2	14000	0	16	-	-10	100	NBR	221G21	4270	481000	8	-	2.0	3448
	25	170	10.2	14000	0	16	6	-10	100	NBR	221G21	4270	486265	14	14	2.0	3448
	25	160	9.6	14000	0	16	-	0	100	FKM	221G2106 ₁	2995	481865	8	-	2.0	3448
	25	160	9.6	14000	0	16	-	0	120	FKM	221G2106 ₁	4270	481000	8	-	2.0	3448
	25	160	9.6	14000	0	16	6	0	120	FKM	221G2106 ₁	4270	486265	14	14	2.0	3448
	25	160	9.6	14000	0	16	-	-10	100	NBR	221G2110 ₃	2995	481865	8	-	2.0	3448
	25	160	9.6	14000	0	16	-	-10	100	NBR	221G2110 ₃	4270	481000	8	-	2.0	3448
	25	160	9.6	14000	0	16	6	-10	100	NBR	221G2110 ₃	4270	486265	14	14	2.0	3448
	25	170	10.2	14000	0	-	10	-10	100	NBR	221G2130 ₁₂₄	2995	481865	-	9	2.1	3448
	25	170	10.2	14000	0	10	10	-25	40	NBR	221G2130 ₁₂₄	-	492070	9	8	2.1	3448
	25	170	10.2	14000	0	10	10	-25	40	NBR	221G2130 ₁₂₄	-	492190	11	9	2.1	3448
	25	170	10.2	14000	0	-	10	0	100	FKM	221G2136 ₁	2995	481865	-	9	2.0	3448
25	170	10.2	14000	0	-	10	0	100	FKM	221G2136 ₁	4270	481000	-	8	2.0	3448	

Notes:

1. Valve only compatible with hydraulic oil and air/neutral gases
2. Valves with model number ending in 30 or 31 are only compatible with explosion proof electrical parts shown, or with group 2.1 coils only in DC voltage.
3. With 4 position selector for controlled closure rate
4. Pilot seat in FKM

2 WAY VALVES



For this page	Port size	Orifice (mm)	Kv (l/min)	MOPD (bar)	Fluid Temp (°C)	Amb Temp (°C)
From	1"	15	80	1	-25	-10
To	1"	25	170	20	120	50

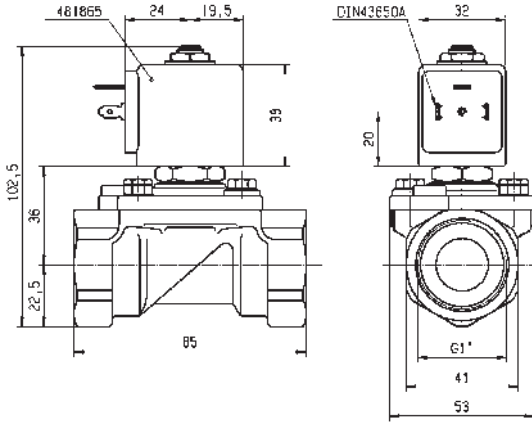

Drawing 3445

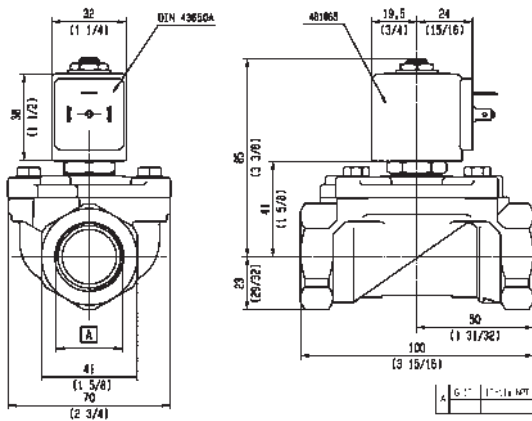

Drawing 3448

2/2

VALVES FOR DRY OR LUBRICATED AIR, NEUTRAL GASES AND LIQUIDS
PILOT OPERATED



Commercial Equipment



Industrial Equipment

BRASS PIPE MOUNTING

NORMALLY CLOSED

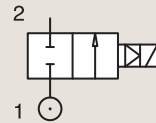

Port size	Orifice Ø	Flow factors			Operating Pressure Differential			Fluid Temp.		Seat Seal	Parker Valves			Power		Coil Group	Dwg. No.
		Kv l/min	KV m³/h	Qn m³/h	Min bar	Max(MOPD) AC bar	DC bar	Min °C	Max °C		Valve Order Number	Valve Type	Coil Type	AC W	DC W		
3/8"	13	33	2	-	0.5	16	-	-10	90	NBR	366501 ₁	PM168.1IN	ZB09	9	-	20.1/20.2	048
	13	33	2	-	0.5	-	16	-10	90	NBR	366501 ₁	PM168.1IN	ZB12	-	12	20.1/20.2	048
	13	50	3	-	0.35	15	-	-10	90	NBR	366770	PM173IN	WB4.5	4.5	-	1.3	054
	13	50	3	-	0.35	-	12	-10	90	NBR	366770	PM173IN	WB5.0	-	5	1.3	054
1/2"	13	42	2.5	-	0.5	16	-	-10	90	NBR	366511 ₁	PM168.1AN	ZB09	9	-	20.1/20.2	046
	13	42	2.5	-	0.5	-	16	-10	90	NBR	366511 ₁	PM168.1AN	ZB12	-	12	20.1/20.2	046
	13	58	3.5	-	0.35	15	-	-10	90	NBR	366775	PM173AN	WB4.5	4.5	-	1.3	053
	13	58	3.5	-	0.35	-	12	-10	90	NBR	366775	PM173AN	WB5.0	-	5	1.3	053
3/4"	20	117	7	-	0.5	16	-	-10	90	NBR	366521 ₁	PM168.1CN	ZB09	9	-	20.1/20.2	046
	20	117	7	-	0.5	-	16	-10	90	NBR	366521 ₁	PM168.1CN	ZB12	-	12	20.1/20.2	046
1"	25	133	8	-	0.5	16	-	-10	90	NBR	366531 ₁	PM168.1DN	ZB09	9	-	20.1/20.2	047
	25	133	8	-	0.5	-	16	-10	90	NBR	366531 ₁	PM168.1DN	ZB12	-	12	20.1/20.2	047

Notes:

1. Valve only compatible with air and neutral gases



For this page	Port size	Orifice (mm)	Kv (l/min)	MOPD (bar)	Fluid Temp (°C)	Amb Temp (°C)
From	3/8"	13	33	12	-10	-10
To	1"	25	133	16	90	50

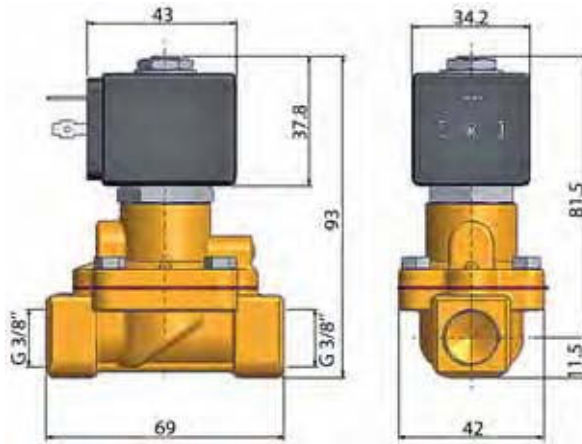

Drawing 048

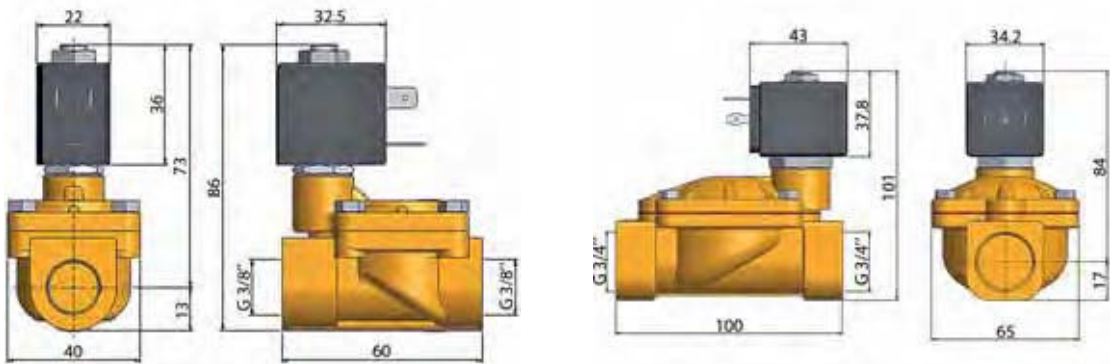

Drawing 054

Drawing 046

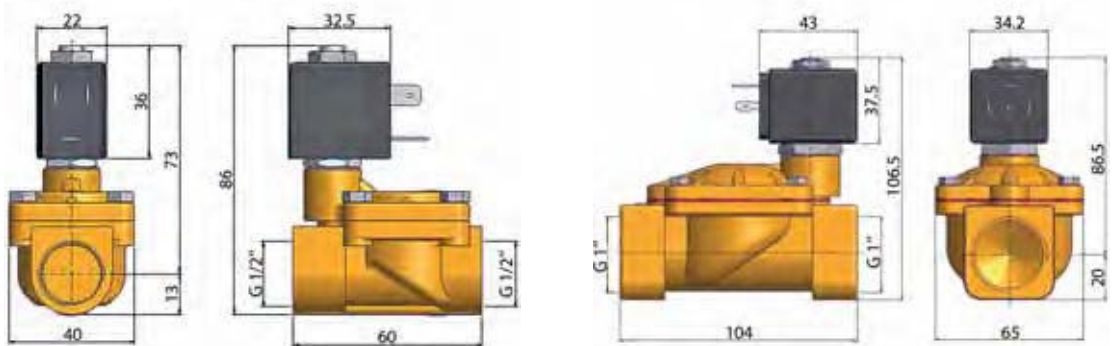

Drawing 053

Drawing 047

2/2

VALVES FOR DRY OR LUBRICATED AIR, NEUTRAL GASES AND LIQUIDS
PILOT OPERATED

BRASS

PIPE MOUNTING

NORMALLY CLOSED

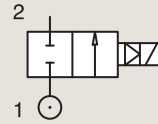

Port size	Orifice Ø	Flow factors			Operating Pressure Differential			Fluid Temp.		Seat Seal	Parker LUCIFER® Valves			Power		Coil Group	Dwg. No.
		Kv l/min	KV m³/h	Qn l/min	Min bar	Max(MOPD) AC bar	DC bar	Min °C	Max °C		Valve Ref.	Housing Ref.	Coil Ref.	AC W	DC W		
1/4"	8	36	2.16	1600	0.3	40	25	-10	100	NBR	E321H11 ¹²⁴	2995	481865	8	9	2.0	3523
	8	36	2.16	1600	0.3	40	30	-10	100	NBR	E321H11 ¹²⁴	4270	481000	8	8	2.0	3523
	8	36	2.16	1600	0.3	40	40	-10	100	NBR	E321H11 ¹²⁴	4270	486265	14	14	2.0	3523
	11	28	1.68	1800	0.2	10	3	-10	100	NBR	E321K10	2995	481865	8	9	2.0	3429
	11	28	1.68	1800	0.2	10	4	-10	100	NBR	E321K10	4270	481000	8	8	2.0	3429
	12	30	1.8	2150	0.3	10	10	-10	100	NBR	321K31	8993	481180	4	5	1.1	7093
	12	30	1.8	2150	0.3	10	7	-10	75	NBR	321K31	8993	488980	2	2.5	1.1	7093
	12	30	1.8	2150	0.3	10	10	-10	100	FKM	321K3106	8993	481180	4	5	1.1	7093
	12	30	1.8	2150	0.3	10	7	-10	75	FKM	321K3106	8993	488980	2	2.5	1.1	7093
	12	32	1.92	2150	0.3	12	12	-10	100	FKM	321K4156 ₃	2995	481865	8	9	2.1/3.0	7094
12	32	1.92	2150	0.3	12	12	-10	120	FKM	321K4156 ₃	4270	481000	8	8	2.1/3.0	7094	

Notes:

1. Minimum pressure differential = 0.3 bar for opening and 0 bar for closing
2. Pilot seat disc in synthetic Ruby
3. Valve with manual override
4. With 4 position selector for controlled closure rate

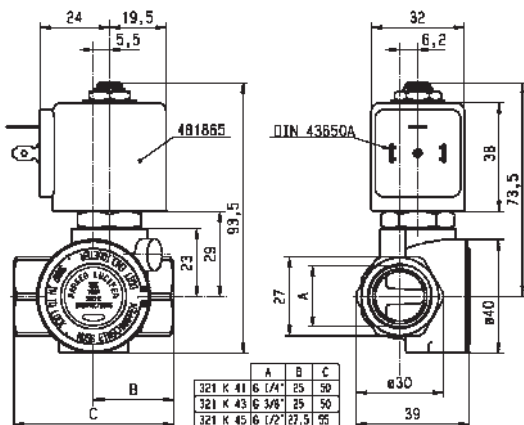

Drawing 7094



For this page	Port size	Orifice (mm)	Kv (l/min)	MOPD (bar)	Fluid Temp (°C)	Amb Temp (°C)
From	1/4"	8	28	3	-10	-10
To	1/4"	12	36	40	120	50

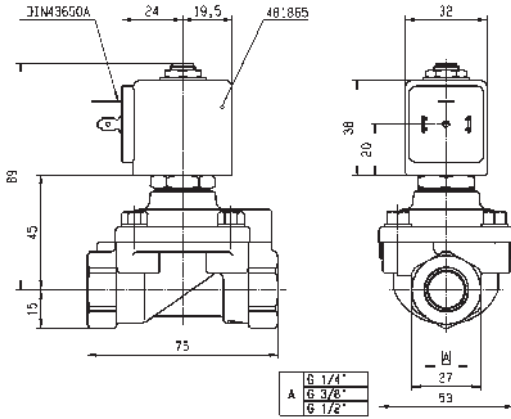

Drawing 3523

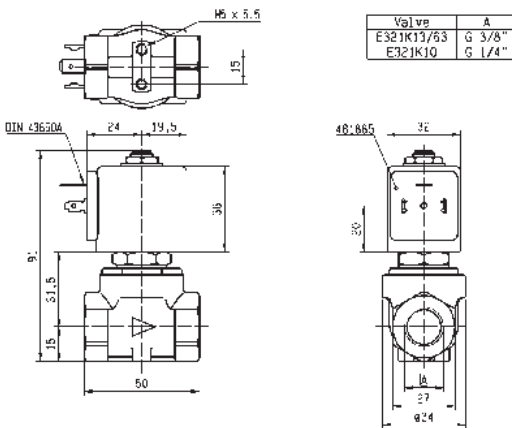

Drawing 3429

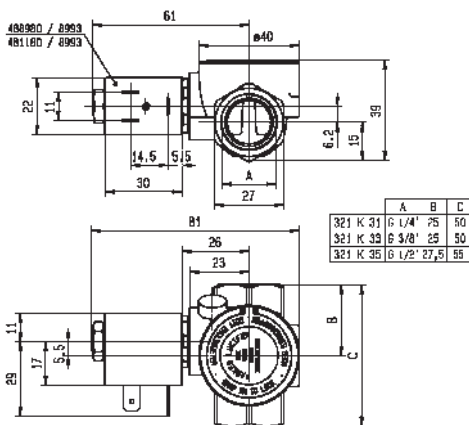

Drawing 7093

2/2

VALVES FOR DRY OR LUBRICATED AIR, NEUTRAL GASES AND LIQUIDS
PILOT OPERATED

BRASS

PIPE MOUNTING

NORMALLY CLOSED

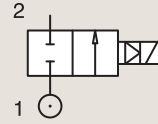

Port size	Orifice Ø	Flow factors			Operating Pressure Differential			Fluid Temp.		Seat Seal	Parker LUCIFER® Valves			Power		Coil Group	Dwg. No.
											Valve Ref.	Housing Ref.	Coil Ref.	AC W	DC W		
BSP	mm	Kv l/min	KV m³/h	Qn l/min	bar	AC bar	DC bar	°C	°C								
3/8"	11	50	3	2800	0.3	40	25	-10	100	NBR	E321H13 ₁₂₄	2995	481865	8	9	2.0	3521
	11	50	3	2800	0.3	40	30	-10	100	NBR	E321H13 ₁₂₄	4270	481000	8	8	2.0	3521
	11	50	3	2800	0.3	40	40	-10	100	NBR	E321H13 ₁₂₄	4270	486265	14	14	2.0	3521
	11	36	2.16	2500	0.2	10	4	-10	100	NBR	E321K13	4270	481000	8	8	2.0	3429
	11	36	2.16	2500	0.2	10	10	-10	100	NBR	E321K13	4270	486265	14	14	2.0	3429
	11	36	2.16	2500	0.2	10	-	-10	100	NBR	E321K1314	2995	483466	8 to 11	-	2.0	3429
	11	36	2.16	2500	0.2	10	10	-10	100	NBR	E321K1314	4270	486265	14	14	2.0	3429
	12	45	2.7	3050	0.3	10	10	-10	100	NBR	321K33	8993	481180	4	5	1.1	7093
	12	45	2.7	3050	0.3	10	7	-10	75	NBR	321K33	8993	488980	2	2.5	1.1	7093
	12	45	2.7	3050	0.3	10	10	-10	100	FKM	321K3306 ₁	8993	481180	4	5	1.1	7093
	12	45	2.7	3050	0.3	10	7	-10	75	FKM	321K3306 ₁	8993	488980	2	2.5	1.1	7093
	12	45	2.7	3050	0.3	12	12	-10	100	FKM	321K4356 ₃	2995	481865	8	9	2.1/3.0	7094
12	45	2.7	3050	0.3	12	12	-10	120	FKM	321K4356 ₃	4270	481000	8	8	2.1/3.0	7094	

Notes:

1. Minimum pressure differential = 0.3 bar for opening and 0 bar for closing
2. Pilot seat disc in synthetic Ruby
3. Valve with manual override
4. With 4 position selector for controlled closure rate

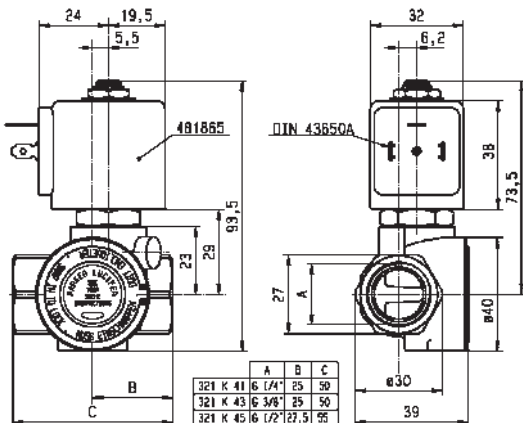

Drawing 7094



For this page	Port size	Orifice (mm)	Kv (l/min)	MOPD (bar)	Fluid Temp (°C)	Amb Temp (°C)
From	3/8"	11	36	4	-10	-10
To	3/8"	12	50	40	120	50

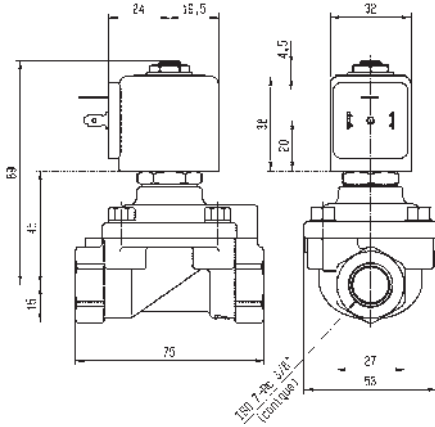

Drawing 3521

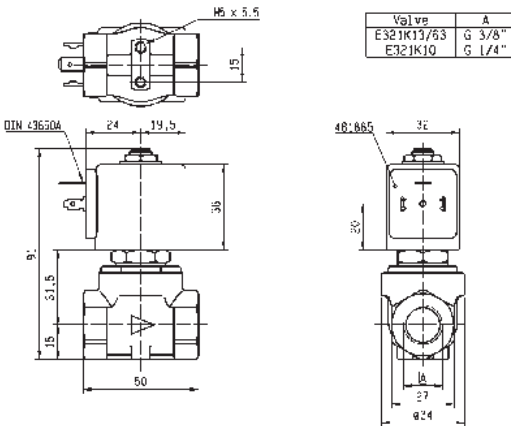

Drawing 3429

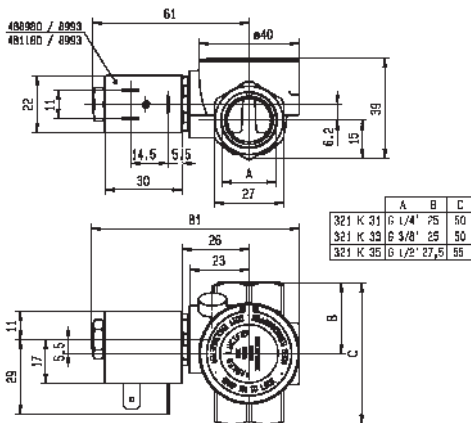

Drawing 7093

2/2

VALVES FOR DRY OR LUBRICATED AIR, NEUTRAL GASES AND LIQUIDS
PILOT OPERATED

BRASS

PIPE MOUNTING

NORMALLY CLOSED

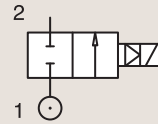

Port size	Orifice Ø	Flow factors			Operating Pressure Differential			Fluid Temp.		Seat Seal	Parker LUCIFER® Valves			IS	Power		Coil Group	Dwg. No.
		Kv l/min	KV m³/h	Qn l/min	Min bar	Max(MOPD) AC bar	DC bar	Min °C	Max °C		Valve Ref.	Housing Ref.	Coil Ref.		AC W	DC W		
1/2"	11	36	2.16	2500	0.2	10	3	-10	100	NBR	E321K15	2995	481865	8	9	2.0	3427	
	11	36	2.16	2500	0.2	10	10	-10	120	NBR	E321K15	4270	486265	14	14	2.0	3427	
	11	36	2.16	2500	0.2	10	3	-10	100	NBR	E321K1514	2995	481865	8	9	2.0	3427	
	11	36	2.16	2500	0.2	10	4	-10	120	NBR	E321K1514	-	483371	8	8	2.0	3427	
	11	36	2.16	2500	0.2	10	3	-10	100	NBR	E321K25	2995	481865	8	9	2.0	3427	
	11	36	2.16	2500	0.2	4	4	-10	120	NBR	E321K25	-	492070	9	8	2.0	3427	
	12	50	3	3400	0.3	10	10	-10	100	NBR	321K35	8993	481180	4	5	1.1	7093	
	12	50	3	3400	0.3	10	7	-10	75	NBR	321K35	8993	488980	2	2.5	1.1	7093	
	12	50	3	3400	0.3	10	10	-10	100	FKM	321K3506	8993	481180	4	5	1.1	7093	
	12	50	3	3400	0.3	10	7	-10	75	FKM	321K3506	8993	488980	2	2.5	1.1	7093	
	15	60	3.6	3150	0.3	-	10	-10	100	NBR	321H1590	2995	483580.01	*	-	0.5 to 3	7.0/8.0	3978
	15	60	3.6	3150	0.3	-	10	-10	100	NBR	321H1590	-	488660.01	*	-	0.3 to 3	7.0/8.0	3978
	15	60	3.6	3150	0.3	-	10	-10	100	NBR	321H1590	-	495910	*	-	0.3 to 3	7.0/8.0	3978
	15	60	3.6	3150	1.5	40	40	-10	50	PUR	321H35 ²³	2995	481865	8	9	2.1	3522	
	15	60	3.6	3150	1.5	40	40	-10	50	PUR	321H35 ²³	4270	481000	8	8	2.1	3522	
	15	60	3.6	3150	0.3	40	25	-10	100	NBR	E321H15 ¹²⁴	2995	481865	8	9	2.0	3522	
	15	60	3.6	3150	0.3	40	30	-10	100	NBR	E321H15 ¹²⁴	4270	481000	8	8	2.0	3522	
	15	60	3.6	3150	0.3	40	40	-10	100	NBR	E321H15 ¹²⁴	4270	486265	14	14	2.0	3522	

Notes:

1. Minimum pressure differential = 0.3 bar for opening and 0 bar for closing
2. Pilot seat disc in synthetic Ruby
3. Valve with manual override
4. With 4 position selector for controlled closure rate

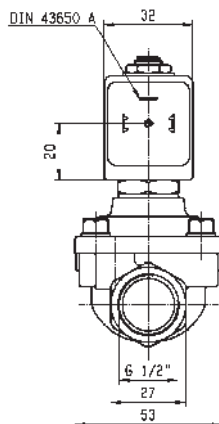
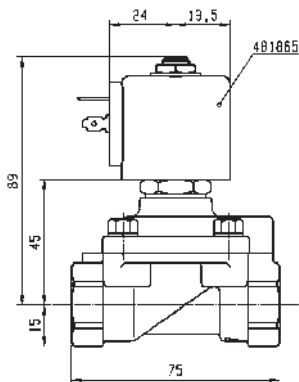

Drawing 3522



For this page	Port size	Orifice (mm)	Kv (l/min)	MOPD (bar)	Fluid Temp (°C)	Amb Temp (°C)
From	1/2"	11	36	3	-10	-10
To	1/2"	15	60	40	120	50

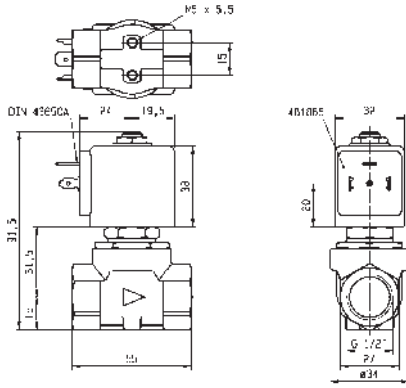

Drawing 3427

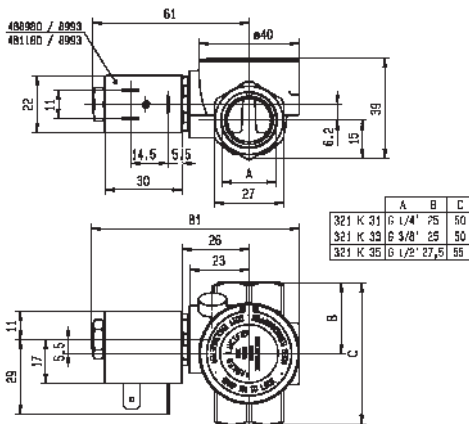

Drawing 7093

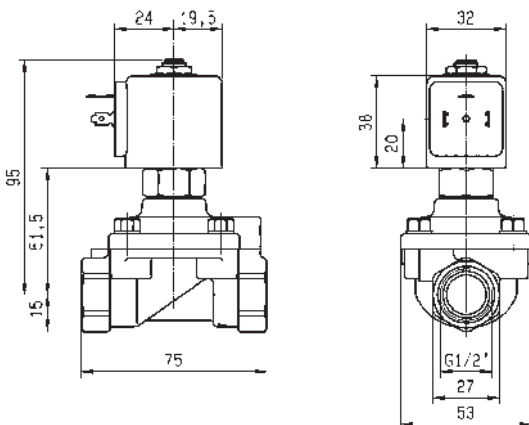

Drawing 3978

2/2

VALVES FOR DRY OR LUBRICATED AIR, NEUTRAL
GASES AND LIQUIDS
PILOT OPERATED

BRASS

PIPE MOUNTING

NORMALLY CLOSED

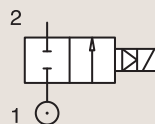

Port size	Orifice Ø	Flow factors			Operating Pressure Differential			Fluid Temp.		Seat Seal	Parker LUCIFER® Valves			Power		Coil Group	Dwg. No.
		Kv l/min	KV m³/h	Qn l/min	Min bar	Max(MOPD) AC bar	DC bar	Min °C	Max °C		Valve Ref.	Housing Ref.	Coil Ref.	AC W	DC W		
3/4"	15	-	-	3550	1.5	40	40	-10	50	PUR	321H36 ₁	2995	481865	8	9	2.1	3696
	15	-	-	3550	1.5	40	40	-10	50	PUR	321H36 ₁	4270	481000	8	8	2.1	3696
	18	100	6	9400	0.3	10	10	-10	100	NBR	321K36	8993	481180	4	5	1.1	7097
	18	100	6	9400	0.3	10	7	-10	75	NBR	321K36	8993	488980	2	2.5	1.1	7097
	18	100	6	9400	0.3	10	10	-10	100	FKM	321K3606	8993	481180	4	5	1.1	7097
	18	100	6	9400	0.3	10	7	-10	75	FKM	321K3606	8993	488980	2	2.5	1.1	7097
	20	135	8.1	9500	0.3	16	16	-10	100	NBR	E321G36	2995	481865	8	9	2.0	3442
	20	135	8.1	9500	0.3	16	16	-10	100	NBR	E321G36	4270	481000	8	8	2.0	3442
	20	135	8.1	9500	0.3	16	16	-10	100	FKM	E321G3606	2995	481865	8	9	2.0/14.1	3442
	20	135	8.1	9500	0.3	16	16	-10	120	FKM	E321G3606	4270	481000	8	8	2.0/14.1	3442
20	135	8.1	9500	0.3	16	16	-10	120	FKM	E321G3606	4270	486265	14	14	2.0/14.1	3442	

Notes:

1. Pilot seat disc in synthetic Ruby



For this page	Port size	Orifice (mm)	Kv (l/min)	MOPD (bar)	Fluid Temp (°C)	Amb Temp (°C)
From	3/4"	15	100	7	-10	-10
To	3/4"	20	135	40	120	50

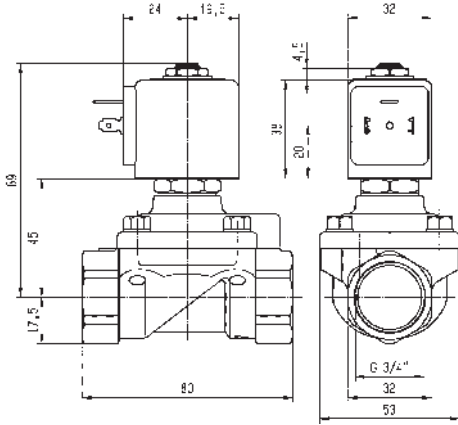

Drawing 3696

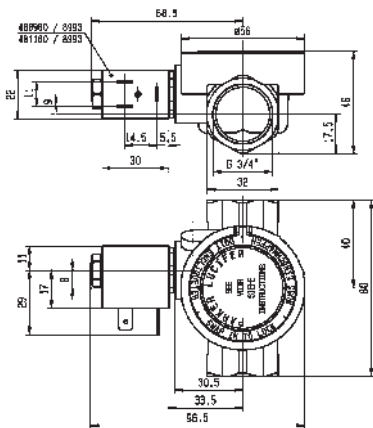

Drawing 7097

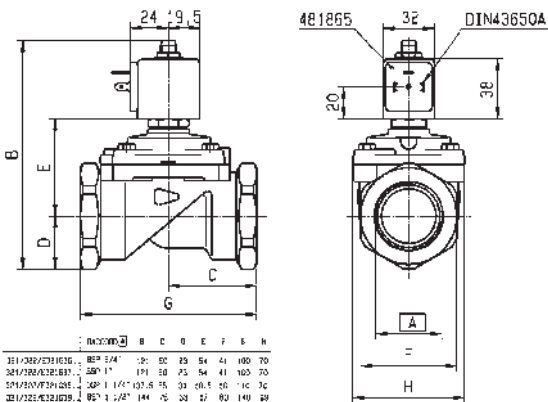

Part No.	Port Size	Orifice	Kv	MOPD	Fluid Temp	Amb Temp
311/322/331/332	3/4"	15	50	54	41	100
324/330/338/339	1"	20	50	54	41	100
316/320/329/330	1/2"	10	25	28	21	50
321/325/333/334	3/8"	8	20	22	16	40
321/326/334/335	1/2"	15	25	28	21	50
321/327/335/336	3/4"	20	32	37	30	60
321/328/336/337	1"	25	40	46	38	75
321/329/337/338	1 1/2"	40	63	70	57	100



Drawing 3442

2/2

VALVES FOR DRY OR LUBRICATED AIR, NEUTRAL
GASES AND LIQUIDS
PILOT OPERATED

BRASS

PIPE MOUNTING

NORMALLY CLOSED

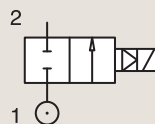

Port size	Orifice Ø	Flow factors			Operating Pressure Differential			Fluid Temp.		Seat Seal	Parker LUCIFER® Valves			IS	Power		Coil Group	Dwg. No.
		Kv l/min	KV m³/h	Qn l/min	Min bar	Max(MOPD) AC bar	DC bar	Min °C	Max °C		Valve Ref.	Housing Ref.	Coil Ref.		AC W	DC W		
1"	18	110	6.6	10150	0.3	10	10	-10	100	NBR	321K37	8993	481180		4	5	1.1	7098
	18	110	6.6	10150	0.3	10	7	-10	75	NBR	321K37	8993	488980		2	2.5	1.1	7098
	18	110	6.6	10150	0.3	10	10	-10	100	FKM	321K3706	8993	481180		4	5	1.1	7098
	18	110	6.6	10150	0.3	10	7	-10	75	FKM	321K3706	8993	488980		2	2.5	1.1	7098
	25	185	11.1	14100	0.3	-	10	-10	75	NBR	321G3790	2995	483580.01	*	-	0.5 to 3	7.0/8.0	3442
	25	185	11.1	14100	0.3	-	10	-10	75	NBR	321G3790	-	488660.01	*	-	0.3 to 3	7.0/8.0	3442
	25	185	11.1	14100	0.3	-	10	-10	75	NBR	321G3790	-	495910	*	-	0.3 to 3	7.0/8.0	3442
	25	180	10.8	14000	0.3	16	16	-10	100	NBR	E321G37	2995	481865		8	9	2.0	3442
	25	180	10.8	14000	0.3	16	16	-10	100	NBR	E321G37	4270	481000		8	8	2.0	3442
	25	180	10.8	14000	0.3	16	16	-10	100	FKM	E321G3706	2995	481865		8	9	2.0/14.1	3442
	25	180	10.8	14000	0.3	16	16	-10	120	FKM	E321G3706	4270	481000		8	8	2.0/14.1	3442
	25	180	10.8	14000	0.3	16	16	-10	120	FKM	E321G3706	4270	486265		14	14	2.0/14.1	3442
	28	270	16.2	18000	0.3	16	16	-10	100	NBR	E321G38	2995	481865		8	9	2.0	3442
	28	270	16.2	18000	0.3	16	16	-10	100	NBR	E321G38	4270	481000		8	8	2.0	3442
	28	270	16.2	18000	0.3	16	16	-10	100	FKM	E321G3806	2995	481865		8	9	2.0	3442
	28	270	16.2	18000	0.3	16	16	-10	120	FKM	E321G3806	4270	481000		8	8	2.0	3442
28	270	16.2	18000	0.3	16	16	-10	100	FKM	E321G3806	4270	486265		14	14	2.0	3442	



For this page	Port size	Orifice (mm)	Kv (l/min)	MOPD (bar)	Fluid Temp (°C)	Amb Temp (°C)
From	1"	18	110	7	-10	-10
To	1"	28	270	16	120	50

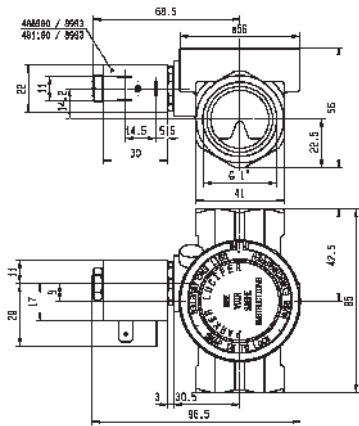

Drawing 7098

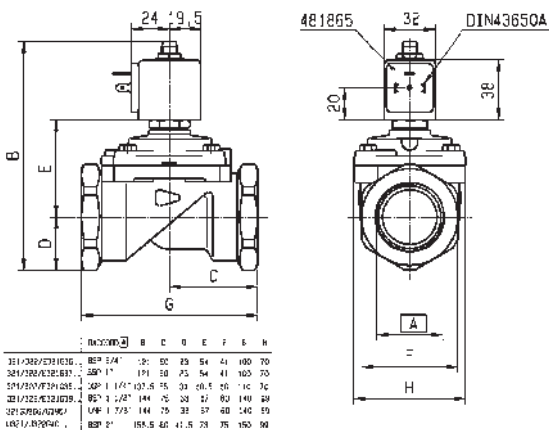

Drawing 3442

2/2

VALVES FOR DRY OR LUBRICATED AIR, NEUTRAL GASES AND LIQUIDS
PILOT OPERATED

BRASS

PIPE MOUNTING

NORMALLY CLOSED

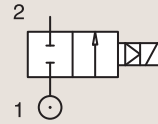

Port size	Orifice Ø	Flow factors			Operating Pressure Differential			Fluid Temp.		Seat Seal	Parker LUCIFER® Valves			IS	Power		Coil Group	Dwg. No.
		Kv l/min	KV m³/h	Qn l/min	Min bar	Max(MOPD) AC bar	DC bar	Min °C	Max °C		Valve Ref.	Housing Ref.	Coil Ref.		AC W	DC W		
1 1/2"	40	425	25.5	31500	0.5	-	10	-10	75	NBR	321G3990	2995	483580.01	*	-	0.5 to 3	7.0/8.0	8113
	40	425	25.5	31500	0.5	-	10	-10	75	NBR	321G3990	-	488660.01	*	-	0.3 to 3	7.0/8.0	8113
	40	425	25.5	31500	0.5	-	10	-10	75	NBR	321G3990	-	495910	*	-	0.3 to 3	7.0/8.0	8113
	40	420	25.2	31500	0.3	16	7	-10	100	NBR	E321G39 ₁	2995	481865		8	9	2.0	3442
	40	420	25.2	31500	0.3	16	8.5	-10	100	NBR	E321G39 ₁	4270	481000		8	8	2.0	3442
	40	420	25.2	31500	0.3	16	7	-10	100	FKM	E321G3906	2995	481865		8	9	2.0	3442
	40	420	25.2	31500	0.3	16	8.5	-10	120	FKM	E321G3906	4270	481000		8	8	2.0	3442
	40	420	25.2	31500	0.3	16	16	-10	100	FKM	E321G3906	4270	486265		14	14	2.0	3442
2"	40	540	32.4	38100	0.5	-	10	-10	75	NBR	321G4090	2995	483580.01	*	-	0.5 to 3	7.0/8.0	8113
	40	540	32.4	38100	0.5	-	10	-10	75	NBR	321G4090	-	488660.01	*	-	0.3 to 3	7.0/8.0	8113
	40	540	32.4	38100	0.5	-	10	-10	75	NBR	321G4090	-	495910	*	-	0.3 to 3	7.0/8.0	8113
	40	540	32.4	40000	0.3	16	7	-10	100	NBR	E321G40 ₁	2995	481865		8	9	2.0	3442
	40	540	32.4	40000	0.3	16	8.5	-10	100	NBR	E321G40 ₁	4270	481000		8	8	2.0	3442
	40	540	32.4	40000	0.3	16	7	-10	100	FKM	E321G4006	2995	481865		8	9	2.0	3442
	40	540	32.4	40000	0.3	16	8.5	-10	120	FKM	E321G4006	4270	481000		8	8	2.0	3442
	40	540	32.4	40000	0.3	16	7	-10	120	FKM	E321G4006	4270	486265		14	14	2.0	3442

Notes:

1. Pilot seat disc in synthetic Ruby



For this page	Port size	Orifice (mm)	Kv (l/min)	MOPD (bar)	Fluid Temp (°C)	Amb Temp (°C)
From	1 1/2"	40	420	7	-10	-10
To	2"	40	540	16	120	50

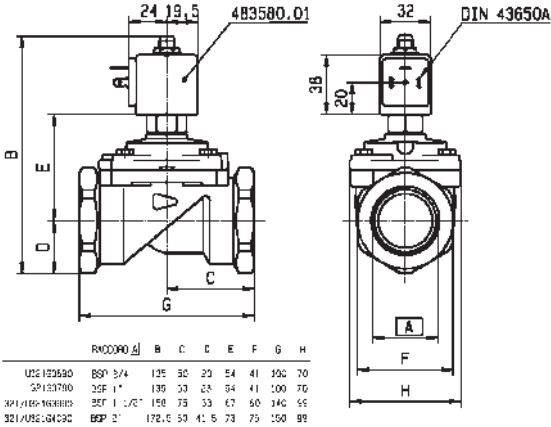

Drawing 8113

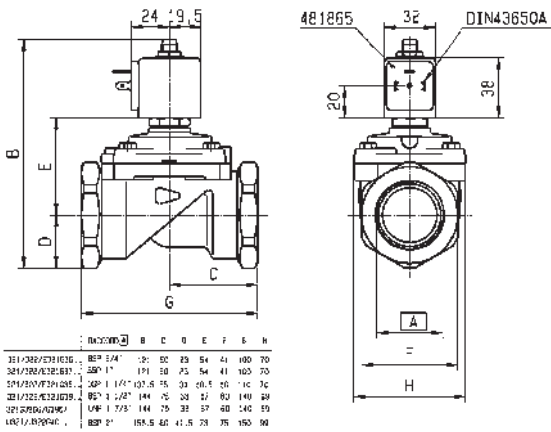

Drawing 3442

2/2

VALVES FOR DRY OR LUBRICATED AIR, NEUTRAL GASES AND LIQUIDS
PILOT OPERATED

BRASS

PIPE MOUNTING

NORMALLY OPEN

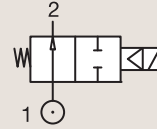

Port size	Orifice Ø	Flow factors			Operating Pressure Differential			Fluid Temp.		Seat Seal	Parker Valves			Power		Coil Group	Dwg. No.
		Kv l/min	KV m³/h	Qn m³/h	Min bar	Max(MOPD) AC bar	DC bar	Min °C	Max °C		Valve Order Number	Valve Type	Coil Type	AC W	DC W		
3/8"	13	33	2	-	0.5	-	16	-10	90	NBR	366601 ₁	PM169.1IN	ZB16	-	12	20.1/20.2	052
	13	33	2	-	0.5	16	-	-10	90	NBR	366601 ₁	PM169.1IN	ZH14	9	-	20.1/20.2	052
1/2"	13	42	2.5	-	0.5	-	16	-10	90	NBR	366606 ₁	PM169.1AN	ZB16	-	12	20.1/20.2	049
	13	42	2.5	-	0.5	16	-	-10	90	NBR	366606 ₁	PM169.1AN	ZH14	9	-	20.1/20.2	049
3/4"	20	117	7	-	0.5	-	16	-10	90	NBR	366611 ₁	PM169.1CN	ZB16	-	12	20.1/20.2	050
	20	117	7	-	0.5	16	-	-10	90	NBR	366611 ₁	PM169.1CN	ZH14	9	-	20.1/20.2	050
1"	25	133	8	-	0.5	-	16	-10	90	NBR	366616 ₁	PM169.1DN	ZB16	-	12	20.1/20.2	051
	25	133	8	-	0.5	16	-	-10	90	NBR	366616 ₁	PM169.1DN	ZH14	9	-	20.1/20.2	051

Notes:

1. Valve only compatible with air and neutral gases

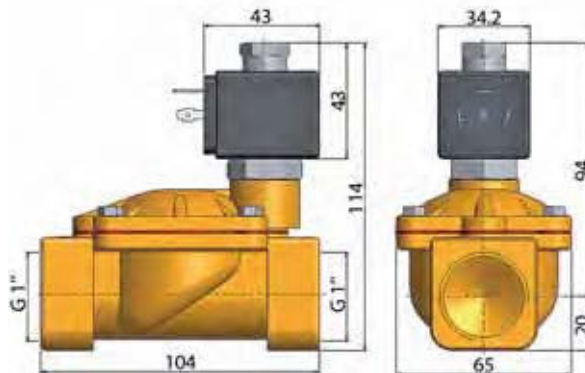

Drawing 051



For this page	Port size	Orifice (mm)	Kv (l/min)	MOPD (bar)	Fluid Temp (°C)	Amb Temp (°C)
From	3/8"	13	33	16	-10	-10
To	1"	25	133	16	90	50

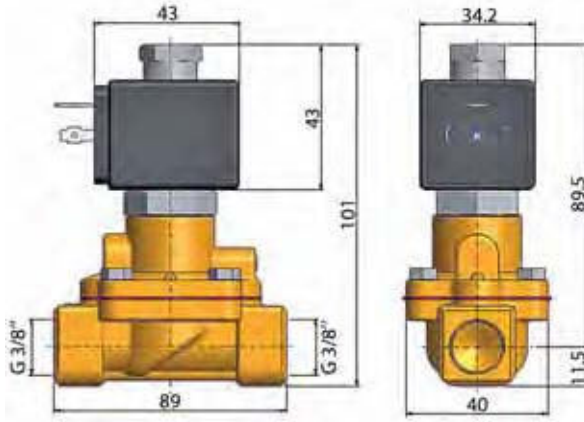

Drawing 052

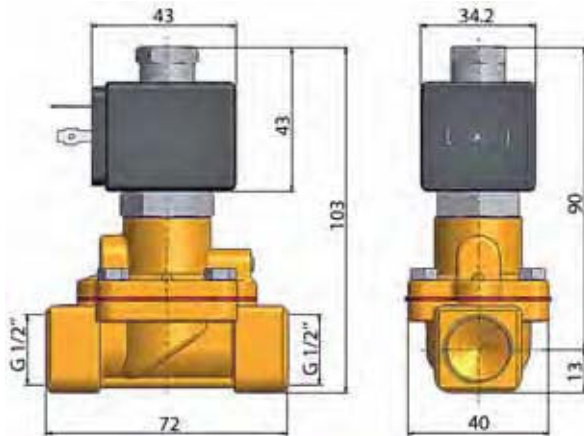

Drawing 049

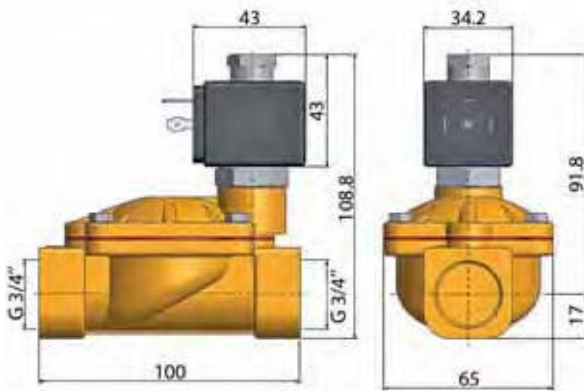

Drawing 050

2/2

VALVES FOR DRY OR LUBRICATED AIR, NEUTRAL GASES AND LIQUIDS
PILOT OPERATED

BRASS

PIPE MOUNTING

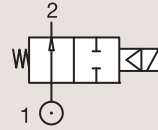

NORMALLY OPEN

Port size	Orifice Ø	Flow factors			Operating Pressure Differential			Fluid Temp.		Seat Seal	Parker LUCIFER® Valves			Power		Coil Group	Dwg. No.
					Min	Max(MOPD)		Min	Max		Valve Ref.	Housing Ref.	Coil Ref.	AC W	DC W		
						bar	AC bar										
BSP	mm	Kv l/min	KV m³/h	Qn l/min	bar	AC bar	DC bar	°C	°C								
1/4"	8	36	2.16	1600	0.3	40	25	-10	100	NBR	322H71 ₁₂	2995	481865	8	9	2.0	3523
	8	36	2.16	1600	0.3	40	30	-10	100	NBR	322H71 ₁₂	4270	481000	8	8	2.0	3523
	8	36	2.16	1600	0.3	40	40	-10	100	NBR	322H71 ₁₂	4270	486265	14	14	2.0	3523
	8	36	2.16	1600	0.3	40	40	-10	100	FKM	322H7106 ₁₂	2995	481865	8	9	2.0/14.1	3523
	8	36	2.16	1600	0.3	40	40	-10	120	FKM	322H7106 ₁₂	4270	481000	8	8	2.0/14.1	3523
	8	36	2.16	1600	0.3	40	40	-10	140	FKM	322H7106 ₁₂	4270	486265	14	14	2.0/14.1	3523
3/8"	11	50	3	3240	0.3	40	40	-10	75	NBR	322H73 ₁₂	2995	481865	8	9	2.0	3523
	11	50	3	3240	0.3	40	40	-10	75	NBR	322H73 ₁₂	4270	481000	8	8	2.0	3523
	11	50	3	3240	0.3	40	40	-10	75	NBR	322H73 ₁₂	4270	486265	14	14	2.0	3523
	11	50	3	3240	0.3	40	40	-10	100	FKM	322H7306 ₁₂	2995	481865	8	9	2.0/14.1	3523
	11	50	3	3240	0.3	40	40	-10	100	FKM	322H7306 ₁₂	4270	481000	8	8	2.0/14.1	3523
	11	50	3	3240	0.3	40	40	-10	140	FKM	322H7306 ₁₂	4270	486265	14	14	2.0/14.1	3523
1/2"	15	60	3.6	3890	0.3	15	15	-10	100	NBR	322G75	2995	481865	8	9	2.1	3522
	15	60	3.6	3890	0.3	15	15	-10	100	NBR	322G75	4270	481000	8	8	2.1	3522
	15	60	3.6	3890	0.3	20	20	-10	100	FKM	322G7506 ₁	2995	481865	8	9	2.0	3522
	15	60	3.6	3890	0.3	20	20	-10	100	FKM	322G7506 ₁	4270	481000	8	8	2.0	3522
	15	60	3.6	3890	0.3	20	20	-10	100	FKM	322G7506 ₁	4270	486265	14	14	2.0	3522
	15	60	3.6	3150	1.5	40	40	-10	50	PUR	322H35 ₃	2995	481865	8	9	2.1	7569
	15	60	3.6	3150	1.5	40	40	-10	50	PUR	322H35 ₃	4270	481000	8	8	2.1	7569
	15	60	3.6	3890	0.3	40	40	-10	100	NBR	322H75 ₁₂	2995	481865	8	9	2.0	3522
	15	60	3.6	3890	0.3	40	40	-10	100	NBR	322H75 ₁₂	4270	481000	8	8	2.0	3522
	15	60	3.6	3890	0.3	40	40	-10	100	NBR	322H75 ₁₂	4270	486265	14	14	2.0	3522
	15	60	3.6	3890	0.3	40	40	-10	100	FKM	322H7506 ₁₂	2995	481865	8	9	2.0/14.1	3522
	15	60	3.6	3890	0.3	40	40	-10	120	FKM	322H7506 ₁₂	4270	481000	8	8	2.0/14.1	3522
	15	60	3.6	3890	0.3	40	40	-10	140	FKM	322H7506 ₁₂	4270	486265	14	14	2.0/14.1	3522

Notes:

1. Minimum pressure differential = 0.3 bar for opening and 0 bar for closing
2. Pilot seat disc in synthetic Ruby
3. Valve only compatible with air and neutral gases



For this page	Port size	Orifice (mm)	Kv (l/min)	MOPD (bar)	Fluid Temp (°C)	Amb Temp (°C)
From	1/4"	8	36	15	-10	-10
To	1/2"	15	60	40	140	50

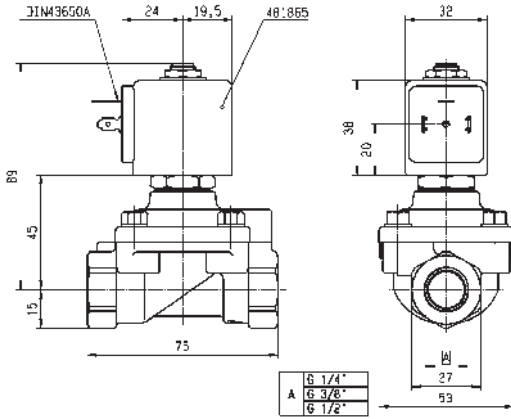

Drawing 3523

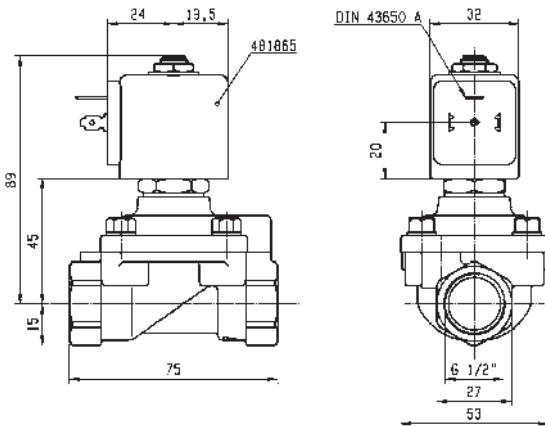

Drawing 3522

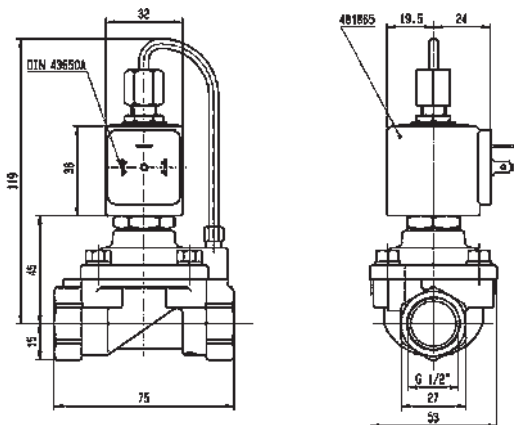

Drawing 7569

2/2

VALVES FOR DRY OR LUBRICATED AIR, NEUTRAL GASES AND LIQUIDS
PILOT OPERATED

BRASS

PIPE MOUNTING

NORMALLY OPEN

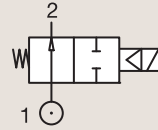

Port size	Orifice Ø	Flow factors			Operating Pressure Differential			Fluid Temp.		Seat Seal	Parker LUCIFER® Valves			Power		Coil Group	Dwg. No.
					Min	Max(MOPD)		Min	Max		Valve Ref.	Housing Ref.	Coil Ref.	AC W	DC W		
					bar	AC bar	DC bar	°C	°C								
BSP	mm	Kv l/min	KV m³/h	Qn l/min	bar	AC bar	DC bar	°C	°C				AC W	DC W			
3/4"	15	-	-	3550	1.5	40	40	-10	50	PUR	322H36 ₁₂	2995	481865	8	9	2.1	7570
	15	-	-	3550	1.5	40	40	-10	50	PUR	322H36 ₁₂	4270	481000	8	8	2.1	7570
	20	135	8.1	9500	0.3	16	16	-10	100	NBR	322G36	2995	481865	8	9	2.1	3442
	20	135	8.1	9500	0.3	16	16	-10	100	NBR	322G36	4270	481000	8	8	2.1	3442
	20	135	8.1	9500	0.3	16	16	-10	100	FKM	322G3606	2995	481865	8	9	2.1	3442
	20	135	8.1	9500	0.3	16	16	-10	120	FKM	322G3606	4270	481000	8	8	2.1	3442
1"	25	180	10.8	14000	0.3	16	16	-10	100	NBR	322G37	2995	481865	8	9	2.1	3442
	25	180	10.8	14000	0.3	16	16	-10	100	NBR	322G37	4270	481000	8	8	2.1	3442
	25	180	10.8	14000	0.3	16	16	-10	100	FKM	322G3706	2995	481865	8	9	2.1	3442
	25	180	10.8	14000	0.3	16	16	-10	120	FKM	322G3706	4270	481000	8	8	2.1	3442
1 1/4"	28	270	16.2	18000	0.3	16	16	-10	100	NBR	322G38	2995	481865	8	9	2.1	3442
	28	270	16.2	18000	0.3	16	16	-10	100	NBR	322G38	4270	481000	8	8	2.1	3442
	28	270	16.2	18000	0.3	16	16	-10	100	FKM	322G3806	2995	481865	8	9	2.1	3442
	28	270	16.2	18000	0.3	16	16	-10	120	FKM	322G3806	4270	481000	8	8	2.1	3442
1 1/2"	40	420	25.2	31500	0.3	12	12	-10	100	NBR	322G39	2995	481865	8	9	2.1	3442
	40	420	25.2	31500	0.3	12	12	-10	100	NBR	322G39	4270	481000	8	8	2.1	3442
	40	420	25.2	31500	0.3	12	12	-10	100	FKM	322G3906	2995	481865	8	9	2.1	3442
	40	420	25.2	31500	0.3	12	12	-10	100	FKM	322G3906	4270	481000	8	8	2.1	3442
2"	40	540	32.4	40000	0.3	12	12	-10	100	NBR	322G40	2995	481865	8	9	2.1	3442
	40	540	32.4	40000	0.3	12	12	-10	100	NBR	322G40	4270	481000	8	8	2.1	3442
	40	540	32.4	40000	0.3	12	12	-10	100	FKM	322G4006	2995	481865	8	9	2.1	3442
	40	540	32.4	40000	0.3	12	12	-10	120	FKM	322G4006	4270	481000	8	8	2.1	3442

Notes:

1. Minimum pressure differential = 1.5 bar for opening and 0.3 bar for closing
2. Valve only compatible with air and neutral gases



For this page	Port size	Orifice (mm)	Kv (l/min)	MOPD (bar)	Fluid Temp (°C)	Amb Temp (°C)
From	3/4"	15	-	12	-10	-10
To	2"	40	540	40	120	50

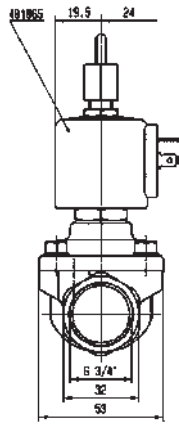
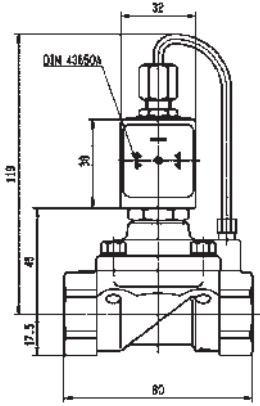

Drawing 7570

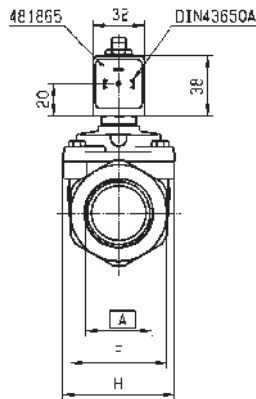
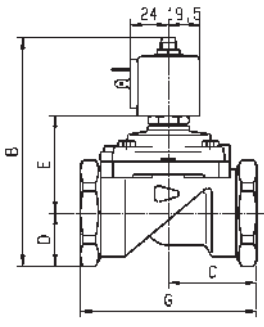

Drawing 3442

Part No.	Port Size	B	C	D	E	F	G	H
311/302/2311016	1/2" NPT	31	50	25	54	41	100	70
321/300/3121017	3/8" NPT	191	50	25	54	41	100	70
501/200/4310101	1/2" NPT	107.5	55	33	60.5	35	110	70
201/321/6121019	1/2" NPT	184	75	33	80	140	80	80
321/300/4210102	3/8" NPT	144	75	33	57	60	140	50
1001/1000/40	1" NPT	155.5	60	41.5	78	75	150	80

2/2

VALVES FOR DRY OR LUBRICATED AIR, NEUTRAL
GASES AND LIQUIDS
PILOT OPERATED

BRASS

PIPE MOUNTING

CONTROL BY ELECTRIC IMPULSE

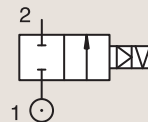

Port size	Orifice Ø	Flow factors			Operating Pressure Differential			Fluid Temp.		Seat Seal	Parker LUCIFER® Valves			Power		Coil Group	Dwg. No.
		Kv l/min	KV m³/h	Qn l/min	Min bar	Max(MOPD) AC bar	DC bar	Min °C	Max °C		Valve Ref.	Housing Ref.	Coil Ref.	AC W	DC W		
1/4"	12	32	1.92	2150	0.3	12	-	-10	100	FKM	325K4106	4269	484990	11	-	4.0	7094
	12	32	1.92	2150	0.3	-	12	-10	100	FKM	325K4106	4269	485400	-	13	4.0	7094
3/8"	12	45	2.7	3050	0.3	12	-	-10	100	FKM	325K4306	4269	484990	11	-	4.0	7094
	12	45	2.7	3050	0.3	-	12	-10	100	FKM	325K4306	4269	485400	-	13	4.0	7094
1/2"	12	50	3	3400	0.3	12	-	-10	100	FKM	325K4506	4269	484990	11	-	4.0	7094
	12	50	3	3400	0.3	-	12	-10	100	FKM	325K4506	4269	485400	-	13	4.0	7094
3/4"	18	100	6	9400	0.3	12	-	-10	100	FKM	325K4606	4269	484990	11	-	4.0	7099
	18	100	6	9400	0.3	-	12	-10	100	FKM	325K4606	4269	485400	-	13	4.0	7099
1"	18	110	6.6	10150	0.3	12	-	-10	100	FKM	325K4706	4269	484990	11	-	4.0	7100
	18	110	6.6	10150	0.3	-	12	-10	100	FKM	325K4706	4269	485400	-	13	4.0	7100



For this page	Port size	Orifice (mm)	Kv (l/min)	MOPD (bar)	Fluid Temp (°C)	Amb Temp (°C)
From	1/4"	12	32	12	-10	-10
To	1"	18	110	12	100	50

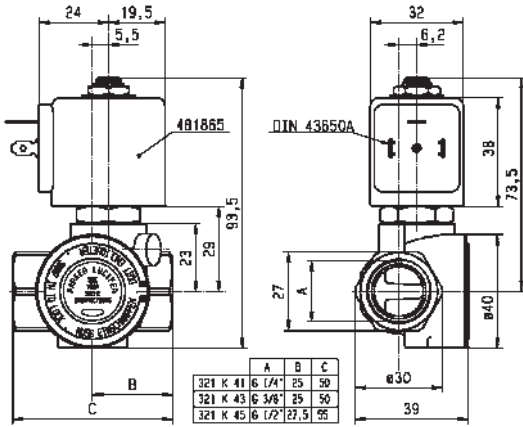

Drawing 7094

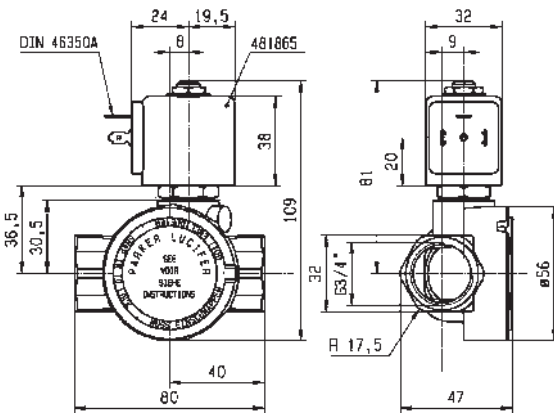

Drawing 7099

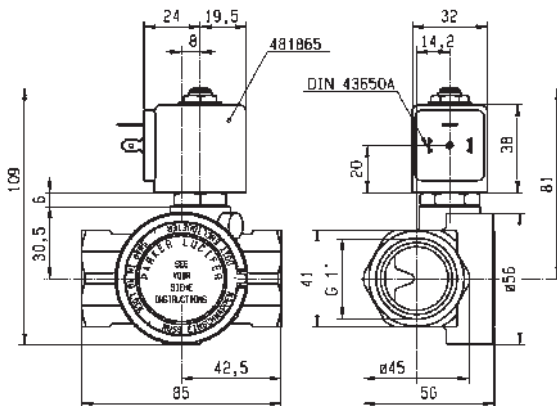

Drawing 7100

2/2

VALVES FOR DRY OR LUBRICATED AIR, NEUTRAL GASES AND LIQUIDS
PILOT OPERATED

BRASS

SUB-BASE MOUNTING

NORMALLY CLOSED

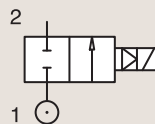

Port size	Orifice Ø mm	Flow factors			Operating Pressure Differential			Fluid Temp.		Seat Seal	Parker LUCIFER® Valves			Power		Coil Group	Dwg. No.
		Kv l/min	KV m³/h	Qn l/min	Min bar	Max(MOPD)		Min °C	Max °C		Valve Ref.	Housing Ref.	Coil Ref.	AC W	DC W		
						AC bar	DC bar										
SB	14	-	-	2100	1.5	40	40	-10	50	PUR	321F35	2995	481865	8	9	2.0	3520
	14	-	-	2100	1.5	40	40	-10	50	PUR	321F35	2995	492425	14	14	2.0	3520
	14	-	-	2100	0	13	13	-10	50	PUR	421F35	2995	481865	8	9	2.1	3520
	14	45	2.7	2100	0.3	40	25	-10	100	NBR	E321F32 ₂	2995	481865	8	9	2.0	3520
	14	45	2.7	2100	0.3	40	30	-10	100	NBR	E321F32 ₂	4270	481000	8	8	2.0	3520
	14	45	2.7	2100	0.3	40	40	-10	100	NBR	E321F32 ₂	4270	486265	14	14	2.0	3520
	14	45	2.7	-	0.3	40	25	-10	100	FKM	E321F3202 ₁₂₃₄	2995	481865	8	9	2.0	3520
	14	45	2.7	-	0.3	40	30	-10	120	FKM	E321F3202 ₁₂₃₄	4270	481000	8	8	2.0	3520
14	45	2.7	-	0.3	40	40	-10	140	FKM	E321F3202 ₁₂₃₄	4270	486265	14	14	2.0	3520	

Notes:

1. Minimum pressure differential = 0.3 bar for opening and 0 bar for closing
2. Pilot seat disc in synthetic Ruby
3. Valve only compatible with hydraulic oil and neutral liquids
4. With 4 position selector for controlled closure rate

BRASS

SUB-BASE MOUNTING

NORMALLY OPEN

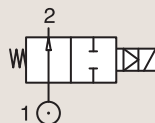

Port size	Orifice Ø mm	Flow factors			Operating Pressure Differential			Fluid Temp.		Seat Seal	Parker LUCIFER® Valves			Power		Coil Group	Dwg. No.
		Kv l/min	KV m³/h	Qn l/min	Min bar	Max(MOPD)		Min °C	Max °C		Valve Ref.	Housing Ref.	Coil Ref.	AC W	DC W		
						AC bar	DC bar										
SB	14	-	-	2100	1.5	40	40	-10	50	PUR	322F35	2995	481865	8	9	2.1	7527
	14	46	2.76	-	0.3	40	40	-10	75	NBR	322F72 ₁₂₄	2995	481865	8	9	2.1	3520
	14	46	2.76	-	0.3	40	40	-10	75	NBR	322F72 ₁₂₄	4270	481000	8	8	2.1	3520
	14	45	2.7	-	0.3	40	40	0	100	FKM	322F7206 ₁₂₃₄	2995	481865	8	9	2.1/14.1	3520
	14	45	2.7	-	0.3	40	40	0	120	FKM	322F7206 ₁₂₃₄	4270	481000	8	8	2.1/14.1	3520

Notes:

1. Minimum pressure differential = 0.3 bar for opening and 0 bar for closing
2. Pilot seat disc in synthetic Ruby
3. Valve only compatible with hydraulic oil and neutral liquids
4. With 4 position selector for controlled closure rate



For this page	Port size	Orifice (mm)	Kv (l/min)	MOPD (bar)	Fluid Temp (°C)	Amb Temp (°C)
From	14 mm	14	-	13	-10	-10
To	14 mm	14	46	40	140	50

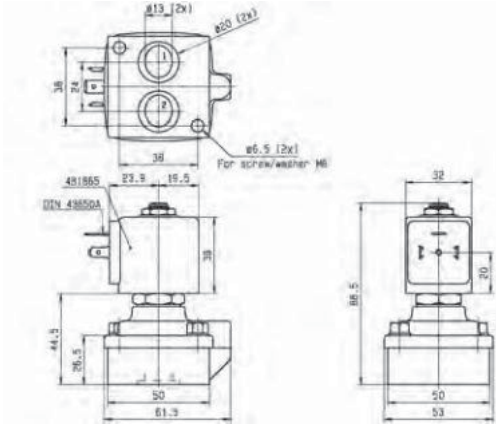

Drawing 3520

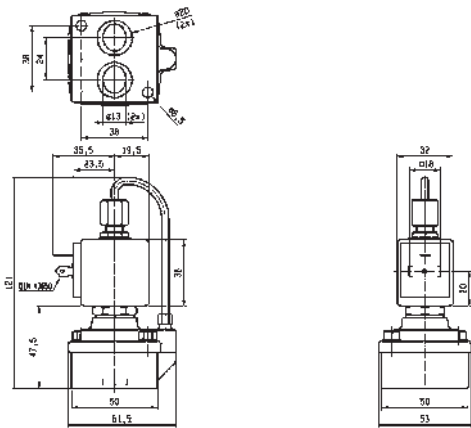

Drawing 7527

2 WAY VALVES



VALVES FOR WATER AND NEUTRAL LIQUIDS



2/2

Actuation	Body	Function	Port Size	Orifice (mm)	Flow Factor Kv(l/min)	MOPD (bar)	Max Fluid Temp. (°C)	Page Parker Valves	Page Parker LUCIFER® Valves		
Direct Operated	Brass/Pipe mounting	Normally Closed	1/8"	1.5 to 3	4.5	20	140	80	84		
			1/4"	1.5 to 6	13	20	140	82	84		
			3/8"	4 to 6	12	10	120	-	86		
		Normally Open	1/2"	8.5 to 11	36	4	120	-	86		
			1/4"	2.5	3	12	120	-	86		
			Control by Electric Impulse		1/4"	5	11	5	100	-	88
			Brass/Sub-base mounting	Normally Closed	SB	2 to 2.5	3	15	140	90	-
5 mm	1.5 to 3	4.5			20	120	-	92			
Pilot Operated	Brass/Pipe mounting	Normally Closed	1/4"	11 to 12	32	12	120	-	98		
			3/8"	11 to 13	50	20	140	94	98		
			1/2"	11 to 13	50	20	140	94	100		
			3/4"	18 to 20	140	20	140	94	102		
			1"	18 to 28	270	20	140	94	104		
			1 1/4"	35	420	10	140	96	-		
			1 1/2"	40	500	16	140	96	104		
			2"	40 to 50	620	16	140	96	104		
			Normally Open	1/4"	12	32	12	120	-	108	
		3/8"		12 to 13	50	20	140	106	108		
		1/2"		12 to 15	60	20	140	106	108		
		3/4"		18 to 20	140	20	140	106	108		
		1"		18 to 25	180	20	140	106	110		
		1 1/4"		35	420	10	140	106	-		
		1 1/2"		40	500	12	140	106	110		
		2"		50	620	10	140	106	-		
		2 1/2"		65	1100	10	90	106	-		
		3"		75	1334	10	90	106	-		
		Brass/Sub-base mounting	Normally Closed	14 mm	14	45	40	100	-	110	

2/2

VALVES FOR WATER AND NEUTRAL LIQUIDS DIRECT OPERATED



Commercial Equipment



Beverage Dispensing



Heating Systems

BRASS PIPE MOUNTING

NORMALLY CLOSED

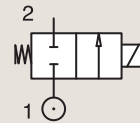

Port size	Orifice Ø	Flow factors			Operating Pressure Differential			Fluid Temp.		Seat Seal	Parker Valves			Power		Coil Group	Dwg. No.
		Kv	KV	Qn	Min	Max(MOPD)	Min	Max	Valve Order Number		Valve Type	Coil Type	AC W	DC W			
BSP	mm	l/min	m³/h	m³/h	bar	AC bar	DC bar	°C	°C								
1/8"	1.5	1.5	0.09	-	0	20	-	-10	140	FKM	363378	PM146BV	ZB09	9	-	20.1/20.2	034
	1.5	1.5	0.09	-	0	-	18	-10	140	FKM	363378	PM146BV	ZB12	-	12	20.1/20.2	034
	2.2	2	0.12	-	0	10	-	-10	140	FKM	392349 ₁₂	161.4AV	KT09 115/50	9	-	22.0	043
	2.2	2	0.12	-	0	10	-	-10	140	FKM	392355 ₁₂	161.4AV	KT09 230/50	9	-	22.0	043
	2.2	2	0.12	-	0	10	-	-10	140	FKM	392335 ₁₂	161.4AV	KT09 24/50	9	-	22.0	043
	2.2	2	0.12	-	0	10	-	-10	140	FKM	392366 ₁₂	161.4AV	KT09 240/50	9	-	22.0	043
	2.2	2	0.12	-	0	-	6	-10	140	FKM	392372 ₁₂	161.4AV	KT10 12 DC	-	10	22.0	043
	2.2	2	0.12	-	0	-	6	-10	140	FKM	392370 ₁₂	161.4AV	KT10 24 DC	-	10	22.0	043
	2.5	3.3	0.20	-	0	10	-	-10	140	FKM	363380	PM146FV	ZB09	9	-	20.1/20.2	034
	2.5	3.3	0.20	-	0	-	5	-10	140	FKM	363380	PM146FV	ZB12	-	12	20.1/20.2	034
	2.8	2.9	0.17	-	0	6	-	-10	140	FKM	392389 ₁₂	161.4BV	KT09 115/60	9	-	22.0	043
	2.8	2.9	0.17	-	0	6	-	-10	140	FKM	392388 ₁₂	161.4BV	KT09 230/50	9	-	22.0	043
	3	4.5	0.27	-	0	7	-	-10	140	FKM	363390	PM146HV	ZB09	9	-	20.1/20.2	034
	3	4.5	0.27	-	0	-	2	-10	140	FKM	363390	PM146HV	ZB12	-	12	20.1/20.2	034

Notes:

1. Maximum pressure for steam: 4 Bar (140°C)
2. Ordering number is for an assembled valve and coil, with the voltage shown.



For this page	Port size	Orifice (mm)	Kv (l/min)	MOPD (bar)	Fluid Temp (°C)	Amb Temp (°C)
From	1/8"	1.5	1.5	2	-10	-10
To	1/8"	3	4.5	20	140	50

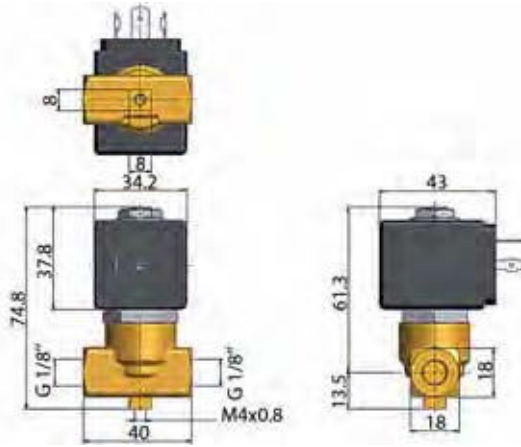

Drawing 034

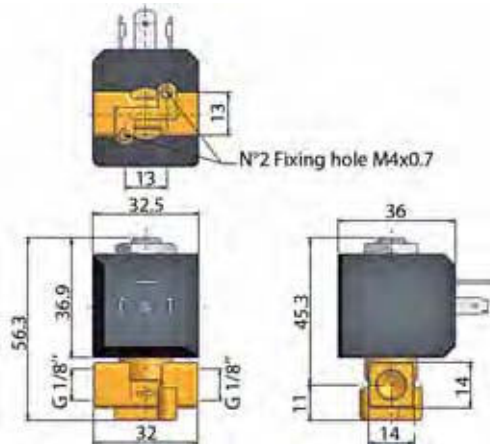

Drawing 043

2/2

VALVES FOR WATER AND NEUTRAL LIQUIDS
DIRECT OPERATED

BRASS

PIPE MOUNTING

NORMALLY CLOSED

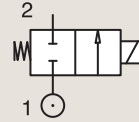

Port size	Orifice Ø	Flow factors			Operating Pressure Differential			Fluid Temp.		Seat Seal	Parker Valves			Power		Coil Group	Dwg. No.	
		Kv l/min	KV m³/h	Qn m³/h	Min bar	Max(MOPD) AC bar	DC bar	Min °C	Max °C		Valve Order Number	Valve Type	Coil Type	AC W	DC W			
BSP	2.2	2	0.12	-	0	10	-	-10	140	FKM	392408 ₁₂	161.4EV	KT09 115/50	9	-	22.0	044	
	2.2	2	0.12	-	0	10	-	-10	140	FKM	392408 ₁₂	161.4EV	KT09 115/60	9	-	22.0	044	
	2.2	2	0.12	-	0	10	-	-10	140	FKM	392409 ₁₂	161.4EV	KT09 208-230/60	9	-	22.0	044	
	2.2	2	0.12	-	0	10	-	-10	140	FKM	392395 ₁₂	161.4EV	KT09 230/50	9	-	22.0	044	
	2.2	2	0.12	-	0	10	-	-10	140	FKM	392173 ₁₂	161.4EV	KT09 24/50	9	-	22.0	044	
	2.2	2	0.12	-	0	10	-	-10	140	FKM	392396 ₁₂	161.4EV	KT09 240/50	9	-	22.0	044	
	1/4"	2.2	2	0.12	-	0	-	6	-10	140	FKM	392170 ₁₂	161.4EV	KT10 12V DC	-	10	22.0	044
		2.2	2	0.12	-	0	-	6	-10	140	FKM	392169 ₁₂	161.4EV	KT10 24 DC	-	10	22.0	044
		3	4.5	0.27	-	0	7	-	-10	140	FKM	363444	PM146YV	ZB09	9	-	20.1/20.2	035
		3	4.5	0.27	-	0	-	2	-10	140	FKM	363444	PM146YV	ZB12	-	12	20.1/20.2	035
		4.5	9	0.53	-	0	6	-	-10	140	FKM	363457	PM146.3KV	ZB14	14	-	20.2	035
		4.5	9	0.53	-	0	-	2.5	-10	140	FKM	363457	PM146.3KV	ZB16	-	16	20.2	035
6	13	0.75	-	0	6	-	-10	140	FKM	363467	PM146.3ABV	ZB14	14	-	20.2	035		
	6	13	0.75	-	0	-	1	-10	140	FKM	363467	PM146.3ABV	ZB16	-	16	20.2	035	

Notes:

1. Maximum pressure for steam: 4 Bar (140°C)
2. Ordering number is for an assembled valve and coil, with the voltage shown.



For this page	Port size	Orifice (mm)	Kv (l/min)	MOPD (bar)	Fluid Temp (°C)	Amb Temp (°C)
From	1/4"	2.2	2	1	-10	-10
To	1/4"	6	13	10	140	50

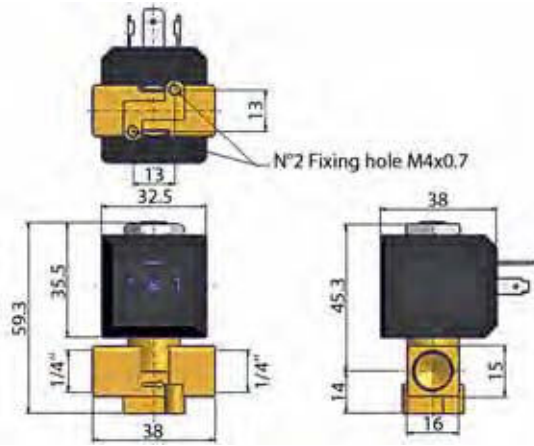

Drawing 044

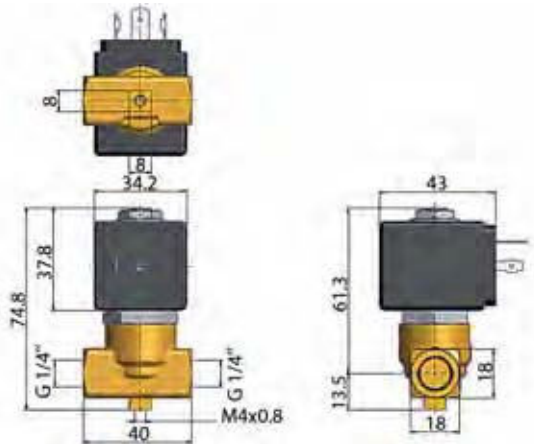

Drawing 035

2/2

VALVES FOR WATER AND NEUTRAL LIQUIDS
DIRECT OPERATED

BRASS

PIPE MOUNTING

NORMALLY CLOSED

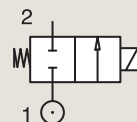

Port size	Orifice Ø	Flow factors			Operating Pressure Differential			Fluid Temp.		Seat Seal	Parker LUCIFER® Valves			Power		Coil Group	Dwg. No.
		Kv l/min	KV m³/h	Qn l/min	Min bar	Max(MOPD) AC bar	DC bar	Min °C	Max °C		Valve Ref.	Housing Ref.	Coil Ref.	AC W	DC W		
1/8"	1.5	0.9	0.05	70	0	20	12	-10	75	FKM	121M14	8993	481180	4	5	1.1	3382
	1.5	0.9	0.05	70	0	20	4	-10	75	FKM	121M14	8993	488980	2	2.5	1.1	3382
	2	2	0.12	125	0	10	7	-10	75	FKM	121M13	8993	481180	4	5	1.1	3382
	2	2	0.12	125	0	10	2.5	-10	75	FKM	121M13	8993	488980	2	2.5	1.1	3382
1/4"	1.5	1.5	0.09	80	0	20	20	-10	100	FKM	E121K0402	2995	481865	8	9	2.0/3.0	3510
	1.5	1.5	0.09	80	0	20	20	-10	120	FKM	E121K0402	4270	481000	8	8	2.0/3.0	3510
	2.5	3.5	0.21	220	0	14	7	-10	100	FKM	121K0706	2995	481865	8	9	2.0	3510
	2.5	3.5	0.21	220	0	14	9	-10	120	FKM	121K0706	4270	481000	8	8	2.0	3510
	2.5	3.5	0.21	220	0	14	14	-10	120	FKM	121K0706	4270	486265	14	14	2.0	3510
	3	4.5	0.27	320	0	10	7	-10	100	FKM	E121K0302	2995	481865	8	9	2.0	3510
	3	4.5	0.27	320	0	10	8.5	-10	120	FKM	E121K0302	4270	481000	8	8	2.0	3510
	3	4.5	0.27	320	0	10	7	-10	100	FKM	E121K0302	4270	486265	14	14	2.0	3510
	3	4.5	0.27	320	0	10	7	-10	100	FKM	E121K0352 ₁	2995	481865	8	9	2.0	3510
	3	4.5	0.27	320	0	10	8.5	-10	120	FKM	E121K0352 ₁	4270	481000	8	8	2.0	3510
	3	4.5	0.27	320	0	10	10	-10	120	FKM	E121K0352 ₁	4270	486265	14	14	2.0	3510
	4	7.5	0.45	480	0	10	4	-10	100	FKM	121K02	2995	481865	8	9	2.0	3510
	4	7.5	0.45	480	0	10	5	-10	120	FKM	121K02	4270	481000	8	8	2.0	3510
	4	7.5	0.45	480	0	10	10	-10	120	FKM	121K02	4270	486265	14	14	2.0	3510
	4	7.5	0.45	480	0	10	4	-10	100	FKM	121K0250 ₁	2995	481865	8	9	2.0	3510
	4	7.5	0.45	480	0	10	5	-10	120	FKM	121K0250 ₁	4270	481000	8	8	2.0	3510
	4	7.5	0.45	480	0	10	10	-10	120	FKM	121K0250 ₁	4270	486265	14	14	2.0	3510
	5	11	0.66	750	0	7	2	-10	100	FKM	121K01	2995	481865	8	9	2.0/14.2	3510
	5	11	0.66	750	0	7	2.8	-10	120	FKM	121K01	4270	481000	8	8	2.0/14.2	3510
	5	11	0.66	750	0	7	5	-10	120	FKM	121K01	4270	486265	14	14	2.0/14.2	3510
5	11	0.66	750	0	7	2	-10	100	FKM	121K0106	2995	481865	8	9	2.0	3510	
5	11	0.66	750	0	7	2.8	-10	120	FKM	121K0106	4270	481000	8	8	2.0	3510	
5	11	0.66	750	0	7	5	-10	120	FKM	121K0106	4270	486265	14	14	2.0	3510	
5	11	0.66	750	0	7	2	-10	100	FKM	121K0150 ₁	2995	481865	8	9	2.0	3510	
5	11	0.66	750	0	7	2.8	-10	120	FKM	121K0150 ₁	4270	481000	8	8	2.0	3510	
5	11	0.66	750	0	7	5	-10	120	FKM	121K0150 ₁	4270	486265	14	14	2.0	3510	

Notes:

1. With manual override



For this page	Port size	Orifice (mm)	Kv (l/min)	MOPD (bar)	Fluid Temp (°C)	Amb Temp (°C)
From	1/8"	1.5	0.9	2	-10	-10
To	1/4"	5	11	20	120	50

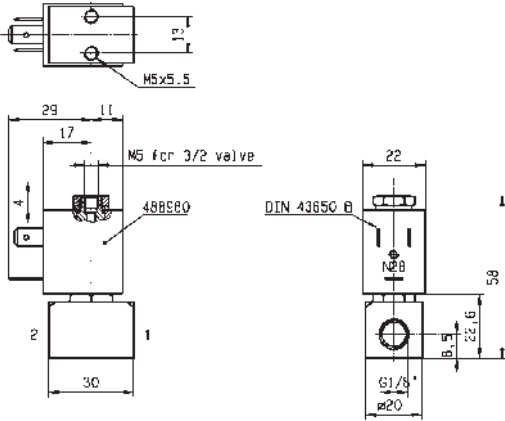

Drawing 3382

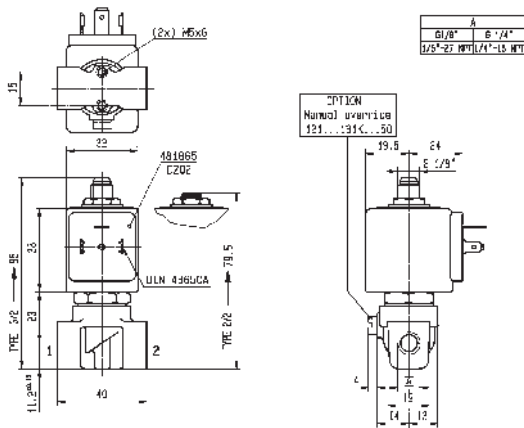

Drawing 3510

2/2

VALVES FOR WATER AND NEUTRAL LIQUIDS DIRECT OPERATED

BRASS

PIPE MOUNTING

NORMALLY CLOSED

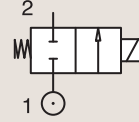

Port size	Orifice Ø	Flow factors			Operating Pressure Differential			Fluid Temp.		Seat Seal	Parker LUCIFER® Valves			Power		Coil Group	Dwg. No.
		Kv l/min	KV m³/h	Qn l/min	Min bar	Max(MOPD) AC bar	DC bar	Min °C	Max °C		Valve Ref.	Housing Ref.	Coil Ref.	AC W	DC W		
3/8"	4	7.5	0.45	480	0	10	4	-10	100	FKM	121K3206	2995	481865	8	9	2.0	3551
	4	7.5	0.45	480	0	10	5	-10	120	FKM	121K3206	4270	481000	8	8	2.0	3551
	4	7.5	0.45	480	0	10	10	-10	120	FKM	121K3206	4270	486265	14	14	2.0	3551
	5	11	0.66	750	0	7	2	-10	100	FKM	121K3106	2995	481865	8	9	2.0	3551
	5	11	0.66	750	0	7	2.8	-10	120	FKM	121K3106	4270	481000	8	8	2.0	3551
	5	11	0.66	750	0	7	5	-10	120	FKM	121K3106	4270	486265	14	14	2.0	3551
	6	12	0.72	1100	0	5	1.1	-10	100	FKM	121K3306	2995	481865	8	9	2.0/14.2	3551
	6	12	0.72	1100	0	5	1.5	-10	120	FKM	121K3306	4270	481000	8	8	2.0/14.2	3551
1/2"	6	12	0.72	1100	0	5	3	-10	120	FKM	121K3306	4270	486265	14	14	2.0/14.2	3551
	8.5	25	1.5	1600	0	1.1	0.5	-10	100	FKM	E121K46	2995	481865	8	9	2.0	3427
	8.5	25	1.5	1600	0	2.2	0.5	-10	120	FKM	E121K46	4270	481000	8	8	2.0	3427
	8.5	25	1.5	1600	0	4	1.2	-10	120	FKM	E121K46	4270	486265	14	14	2.0	3427
	11	36	2.16	2500	0	0.7	0.3	-10	100	FKM	E121K45	2995	481865	8	9	2.0	3427
	11	36	2.16	2500	0	1.2	0.35	-10	120	FKM	E121K45	4270	481000	8	8	2.0	3427
	11	36	2.16	2500	0	2.5	0.7	-10	120	FKM	E121K45	4270	486265	14	14	2.0	3427

BRASS

PIPE MOUNTING

NORMALLY OPEN

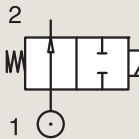

Port size	Orifice Ø	Flow factors			Operating Pressure Differential			Fluid Temp.		Seat Seal	Parker LUCIFER® Valves			Power		Coil Group	Dwg. No.
		Kv l/min	KV m³/h	Qn l/min	Min bar	Max(MOPD) AC bar	DC bar	Min °C	Max °C		Valve Ref.	Housing Ref.	Coil Ref.	AC W	DC W		
1/4"	2.5	3	0.18	180	0	12	12	-10	100	FKM	122K8306	2995	481865	8	9	2.0	3510
	2.5	3	0.18	180	0	12	12	-10	120	FKM	122K8306	4270	481000	8	8	2.0	3510
	2.5	3	0.18	180	0	12	12	-10	120	FKM	122K8306	4270	486265	14	14	2.0	3510



For this page	Port size	Orifice (mm)	Kv (l/min)	MOPD (bar)	Fluid Temp (°C)	Amb Temp (°C)
From	1/4"	2.5	3	0.3	-10	-10
To	1/2"	11	36	12	120	50

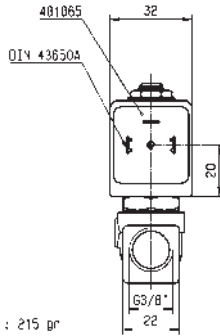
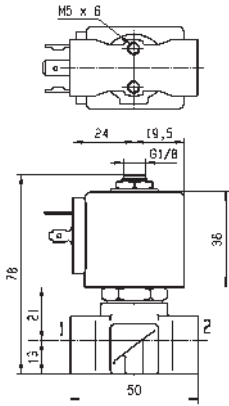

MCI04IT : 215 pr



Drawing 3551

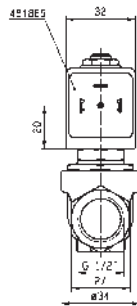
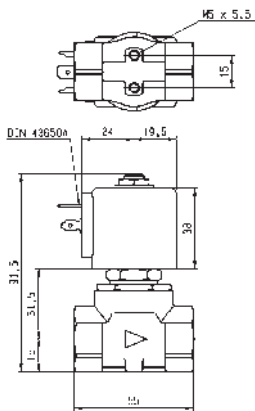

Drawing 3427

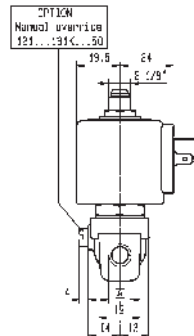
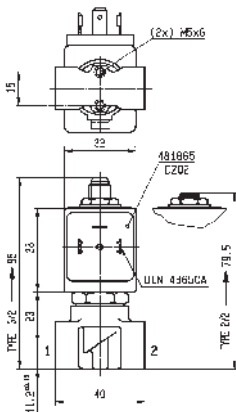

A	
61/8"	6 1/4"
1/8"-21 NPT(1/4"-15 NPT)	

OPTION
Nanvali servitice
321...31C...50



Drawing 3510

2/2

VALVES FOR WATER AND NEUTRAL LIQUIDS DIRECT OPERATED

BRASS

PIPE MOUNTING

CONTROL BY ELECTRIC IMPULSE

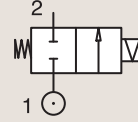

Port size	Orifice Ø	Flow factors			Operating Pressure Differential			Fluid Temp.		Seat Seal	Parker LUCIFER® Valves			Power		Coil Group	Dwg. No.
		Kv l/min	KV m³/h	Qn l/min	Min bar	Max(MOPD) AC bar	DC bar	Min °C	Max °C		Valve Ref.	Housing Ref.	Coil Ref.	AC W	DC W		
1/4"	5	11	0.66	750	0	5	-	-10	100	FKM	125K01	4269	484990	11	-	4.0	8296
	5	11	0.66	750	0	-	1.5	-10	100	FKM	125K01	4269	485400	-	13	4.0	8296



For this page	Port size	Orifice (mm)	Kv (l/min)	MOPD (bar)	Fluid Temp (°C)	Amb Temp (°C)
From	1/4"	5	11	1.5	-10	-10
To	1/4"	5	11	5	100	50

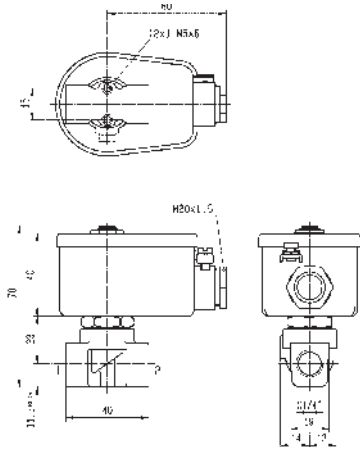

Drawing 8296

2/2

VALVES FOR WATER AND NEUTRAL LIQUIDS DIRECT OPERATED

BRASS

SUB-BASE MOUNTING

NORMALLY CLOSED

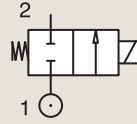

Port size	Orifice Ø mm	Flow factors			Operating Pressure Differential			Fluid Temp.		Seat Seal	Parker Valves			Power		Coil Group	Dwg. No.
		Kv l/min	KV m³/h	Qn m³/h	Min bar	Max(MOPD)		Min °C	Max °C		Valve Order Number	Valve Type	Coil Type	AC W	DC W		
						AC bar	DC bar										
SB	2	2	0.12	-	0	15	-	-10	140	FKM	360469	PM125BV	ZB09	9	-	20.1/20.2	007
	2.5	3	0.18	-	0	10	-	-10	140	FKM	397146J	PM125CV.2	ZB09	9	-	20.1/20.2	007



For this page	Port size	Orifice (mm)	Kv (l/min)	MOPD (bar)	Fluid Temp (°C)	Amb Temp (°C)
From	SB	2	2	10	-10	-10
To	SB	2.5	3	15	140	50

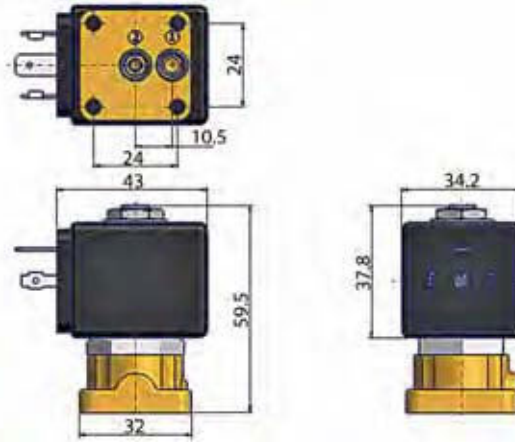

Drawing 007

2/2

VALVES FOR WATER AND NEUTRAL LIQUIDS DIRECT OPERATED

BRASS
SUB-BASE MOUNTING

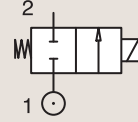

NORMALLY CLOSED

Port size	Orifice Ø			Flow factors			Operating Pressure Differential Max(MOPD)			Fluid Temp.		Seat Seal	Parker LUCIFER® Valves			Power		Coil Group	Dwg. No.
													Valve Ref.	Housing Ref.	Coil Ref.	AC W	DC W		
	mm	Kv l/min	KV m³/h	Qn l/min	Min bar	AC bar	DC bar	Min °C	Max °C	Valve Ref.	Housing Ref.	Coil Ref.						AC W	DC W
SB	1.5	1.5	0.09	80	0	20	20	-10	100	FKM	E121F4406	2995	481865	8	9	2.0	3509		
	1.5	1.5	0.09	80	0	20	20	-10	120	FKM	E121F4406	4270	481000	8	8	2.0	3509		
	1.5	1.5	0.09	80	0	20	20	-10	120	FKM	E121F4406	4270	486265	14	14	2.0	3509		
	3	4.5	0.27	320	0	10	7	-10	100	FKM	E121F4302	2995	481865	8	9	2.0/3.0	3509		
	3	4.5	0.27	320	0	10	8.5	-10	120	FKM	E121F4302	4270	481000	8	8	2.0/3.0	3509		
	3	4.5	0.27	320	0	10	10	-10	120	FKM	E121F4302	4270	486265	14	14	2.0/3.0	3509		



For this page	Port size	Orifice (mm)	Kv (l/min)	MOPD (bar)	Fluid Temp (°C)	Amb Temp (°C)
From	5 mm	1.5	1.5	7	-10	-10
To	5 mm	3	4.5	20	120	50

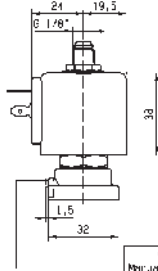
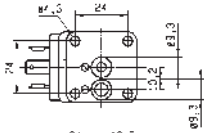

OPTICA
 Model 3500 1/20
 32...131F...50

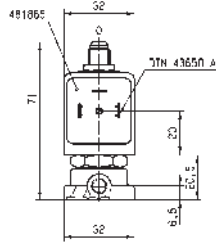

Drawing 3509

2/2

VALVES FOR WATER AND NEUTRAL LIQUIDS PILOT OPERATED



Commercial Equipment



Industrial Equipment



Medical / Instrumentation

BRASS PIPE MOUNTING

NORMALLY CLOSED

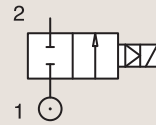

Port size	Orifice Ø	Flow factors			Operating Pressure Differential			Fluid Temp.		Seat Seal	Parker Valves			Power		Coil Group	Dwg. No.
		Kv l/min	KV m³/h	Qn m³/h	Min bar	Max(MOPD) AC bar	DC bar	Min °C	Max °C		Valve Order Number	Valve Type	Coil Type	AC W	DC W		
BSP	mm																
3/8"	13	50	3	-	0.1	10	10	-10	140	EPDM	443778W ₁	7321BIH00	481865	8	9	2.0	028
	13	50	3	-	0.1	20	20	-10	90	NBR	443776W	7321BIN00	481865	8	9	2.0	028
	13	50	3	-	0.1	20	20	-10	90	NBR	443777W ₂	7321BIN01	481865	8	9	2.0	028
	13	50	3	-	0.1	20	20	-10	140	FKM	444492W	7321BIV00	481865	8	9	2.0	028
1/2"	13	50	3	-	0.1	10	10	-10	140	EPDM	443781W ₁	7321BAH00	481865	8	9	2.0	028
	13	50	3	-	0.1	20	20	-10	90	NBR	443779W	7321BAN00	481865	8	9	2.0	028
	13	50	3	-	0.1	20	20	-10	90	NBR	443780W ₂	7321BAN01	481865	8	9	2.0	028
	13	50	3	-	0.1	20	20	-10	140	FKM	444494W	7321BAV00	481865	8	9	2.0	028
3/4"	20	140	8.4	-	0.1	10	10	-10	140	EPDM	443785W ₁	7321BCH00	481865	8	9	2.0	057
	20	140	8.4	-	0.1	20	20	-10	90	NBR	443782W	7321BCN00	481865	8	9	2.0	057
	20	140	8.4	-	0.1	10	10	-10	90	NBR	443783W ₂	7321BCN01	481865	8	9	2.0	057
	20	140	8.4	-	0.1	20	20	-10	140	FKM	444497W	7321BCV00	481865	8	9	2.0	057
1"	25	160	9.6	-	0.1	10	10	-10	140	EPDM	443789W ₁	7321BDH00	481865	8	9	2.0	057
	25	160	9.6	-	0.1	20	20	-10	90	NBR	443786W	7321BDN00	481865	8	9	2.0	057
	25	160	9.6	-	0.1	10	10	-10	90	NBR	443787W ₂	7321BDN01	481865	8	9	2.0	057
	25	160	9.6	-	0.1	20	20	-10	140	FKM	443804W	7321BDV00	481865	8	9	2.0	057

Notes:

- 1. Maximum pressure for steam: 4 Bar (140°C)
- 2. With manual override



For this page	Port size	Orifice (mm)	Kv (l/min)	MOPD (bar)	Fluid Temp (°C)	Amb Temp (°C)
From	3/8"	13	50	10	-10	-10
To	1"	25	160	20	140	50

G	A		B		C	
NPT	mm	inch	mm	inch	mm	inch
3/8"	65	2.71	89.5	3.51	45	1.57
1/2"	72	2.83	101.5	3.99	48	1.57

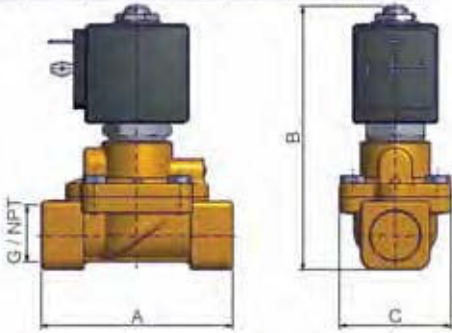

Drawing 028

G	A		B		C	
NPT	mm	inch	mm	inch	mm	inch
3/4"	100	3.93	107	4.21	65	2.56
1"	104	4.09	112.5	4.42	65	2.56

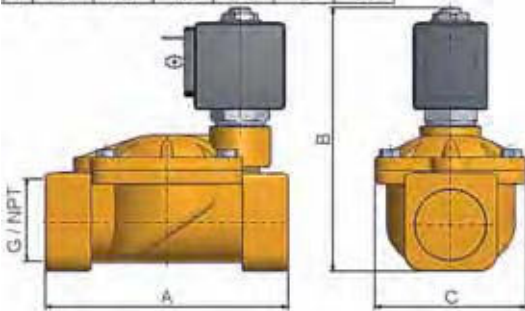

Drawing 057

2/2

VALVES FOR WATER AND NEUTRAL LIQUIDS
PILOT OPERATED

BRASS

PIPE MOUNTING

NORMALLY CLOSED

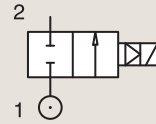

Port size	Orifice Ø	Flow factors			Operating Pressure Differential			Fluid Temp.		Seat Seal	Parker Valves			Power		Coil Group	Dwg. No.
		Kv l/min	KV m³/h	Qn m³/h	Min bar	Max(MOPD) bar	DC bar	Min °C	Max °C		Valve Order Number	Valve Type	Coil Type	AC W	DC W		
1 1/4"	35	420	25.2	-	0.1	10	10	-10	140	EPDM	443793W ₁	7321BEH00	481865	8	9	2.0	058
	35	420	25.2	-	0.1	10	10	-10	90	NBR	443790W	7321BEN00	481865	8	9	2.0	058
	35	420	25.2	-	0.1	5	5	-10	90	NBR	443791W ₂	7321BEN01	481865	8	9	2.0	058
1 1/2"	40	500	30	-	0.1	10	10	-10	140	EPDM	443797W ₁	7321BFH00	481865	8	9	2.0	058
	40	500	30	-	0.1	10	10	-10	90	NBR	443794W	7321BFN00	481865	8	9	2.0	058
	40	500	30	-	0.1	5	5	-10	90	NBR	443795W ₂	7321BFN01	481865	8	9	2.0	058
2"	50	620	37.2	-	0.1	10	10	-10	140	EPDM	443801W ₁	7321BGH00	481865	8	9	2.0	058
	50	620	37.2	-	0.1	10	10	-10	90	NBR	443798W	7321BGN00	481865	8	9	2.0	058
	50	620	37.2	-	0.1	5	5	-10	90	NBR	443799W ₂	7321BGN01	481865	8	9	2.0	058

Notes:

1. Maximum pressure for steam: 4 Bar (140°C)
2. With manual override



For this page	Port size	Orifice (mm)	Kv (l/min)	MOPD (bar)	Fluid Temp (°C)	Amb Temp (°C)
From	1 1/4"	35	420	5	-10	-10
To	2"	50	620	10	140	50

G	A		B		C	
NPT	mm	inch	mm	inch	mm	inch
1/4"	143	5.70	124	5.27	102	4.01
1/2"	143	5.70	134	5.27	102	4.01
3/4"	173	6.81	148	5.82	118	4.64

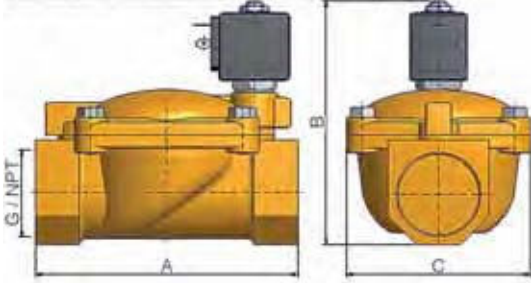

Drawing 058

2/2

VALVES FOR WATER AND NEUTRAL LIQUIDS
PILOT OPERATED

BRASS

PIPE MOUNTING

NORMALLY CLOSED

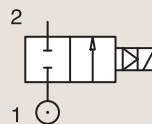

Port size	Orifice Ø	Flow factors			Operating Pressure Differential			Fluid Temp.		Seat Seal	Parker LUCIFER® Valves			Power		Coil Group	Dwg. No.
		Kv l/min	KV m³/h	Qn l/min	Min bar	Max(MOPD) AC bar	DC bar	Min °C	Max °C		Valve Ref.	Housing Ref.	Coil Ref.	AC W	DC W		
1/4"	11	28	1.68	1800	0.2	10	3	-10	100	NBR	E321K10	2995	481865	8	9	2.0	3429
	11	28	1.68	1800	0.2	10	4	-10	100	NBR	E321K10	4270	481000	8	8	2.0	3429
	12	30	1.8	2150	0.3	10	10	-10	100	NBR	321K31	8993	481180	4	5	1.1	7093
	12	30	1.8	2150	0.3	10	7	-10	75	NBR	321K31	8993	488980	2	2.5	1.1	7093
	12	32	1.92	2150	0.3	12	12	-10	100	FKM	321K4106	2995	481865	8	9	2.1/3.0	7094
	12	32	1.92	2150	0.3	12	12	-10	120	FKM	321K4106	4270	481000	8	8	2.1/3.0	7094
3/8"	11	36	2.16	2500	0.2	10	4	-10	100	NBR	E321K13	4270	481000	8	8	2.0	3429
	11	36	2.16	2500	0.2	10	10	-10	100	NBR	E321K13	4270	486265	14	14	2.0	3429
	11	36	2.16	2500	0.2	10	-	-10	100	NBR	E321K1314	2995	483466	8 to 11	-	2.0	3429
	11	36	2.16	2500	0.2	10	10	-10	100	NBR	E321K1314	4270	486265	14	14	2.0	3429
	12	45	2.7	3050	0.3	10	10	-10	100	NBR	321K33	8993	481180	4	5	1.1	7093
	12	45	2.7	3050	0.3	10	7	-10	75	NBR	321K33	8993	488980	2	2.5	1.1	7093
	12	45	2.7	3050	0.3	12	12	-10	100	FKM	321K4306	2995	481865	8	9	2.1/3.0	7094
	12	45	2.7	3050	0.3	12	12	-10	120	FKM	321K4306	4270	481000	8	8	2.1/3.0	7094



For this page	Port size	Orifice (mm)	Kv (l/min)	MOPD (bar)	Fluid Temp (°C)	Amb Temp (°C)
From	1/4"	11	28	3	-10	-10
To	3/8"	12	45	12	120	50

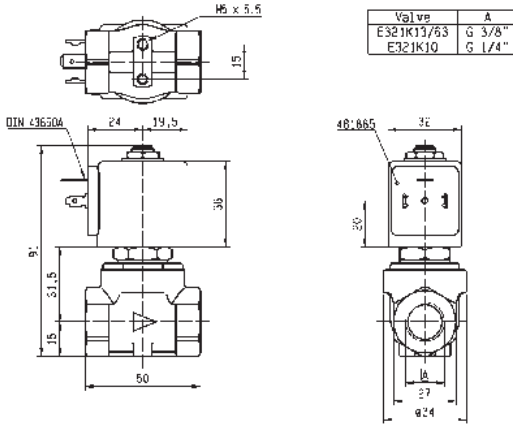

Drawing 3429

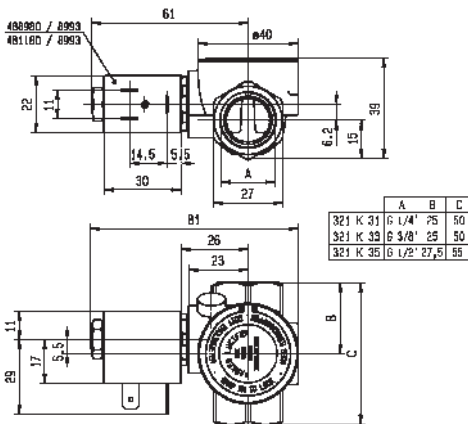

Drawing 7093

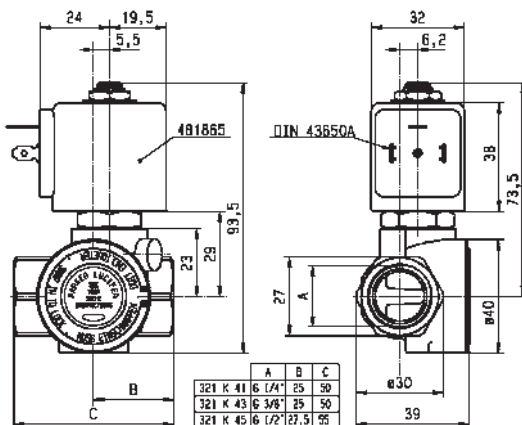

Drawing 7094

2/2

VALVES FOR WATER AND NEUTRAL LIQUIDS
PILOT OPERATED

BRASS

PIPE MOUNTING

NORMALLY CLOSED

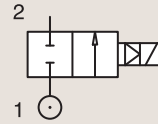

Port size	Orifice Ø	Flow factors			Operating Pressure Differential			Fluid Temp.		Seat Seal	Parker LUCIFER® Valves			Power		Coil Group	Dwg. No.
					Min	Max(MOPD)		Min	Max		Valve Ref.	Housing Ref.	Coil Ref.	AC W	DC W		
						bar	AC bar										
BSP	mm	Kv l/min	KV m³/h	Qn l/min	bar	AC bar	DC bar	°C	°C								
1/2"	11	36	2.16	2500	0.2	10	3	-10	100	NBR	E321K15	2995	481865	8	9	2.0	3427
	11	36	2.16	2500	0.2	10	10	-10	120	NBR	E321K15	4270	486265	14	14	2.0	3427
	11	36	2.16	2500	0.2	10	3	-10	100	NBR	E321K1514	2995	481865	8	9	2.0	3427
	11	36	2.16	2500	0.2	10	4	-10	120	NBR	E321K1514	-	483371	8	8	2.0	3427
	11	36	2.16	2500	0.2	10	3	-10	100	NBR	E321K25	2995	481865	8	9	2.0	3427
	11	36	2.16	2500	0.2	4	4	-10	120	NBR	E321K25	-	492070	9	8	2.0	3427
	12	50	3	3400	0.3	10	10	-10	100	NBR	321K35	8993	481180	4	5	1.1	7093
	12	50	3	3400	0.3	10	7	-10	75	NBR	321K35	8993	488980	2	2.5	1.1	7093
	12	50	3	3400	0.3	12	12	-10	100	FKM	321K4506	2995	481865	8	9	2.1/3.0	7094
	12	50	3	3400	0.3	12	12	-10	120	FKM	321K4506	4270	481000	8	8	2.1/3.0	7094
	12	50	3	3400	0.3	12	12	-10	100	FKM	321K4556	2995	481865	8	9	2.1/3.0	7094
	12	50	3	3400	0.3	12	12	-10	120	FKM	321K4556	4270	481000	8	8	2.1/3.0	7094

Notes:

1. With manual override



For this page	Port size	Orifice (mm)	Kv (l/min)	MOPD (bar)	Fluid Temp (°C)	Amb Temp (°C)
From	1/2"	11	36	3	-10	-10
To	1/2"	12	50	12	120	50

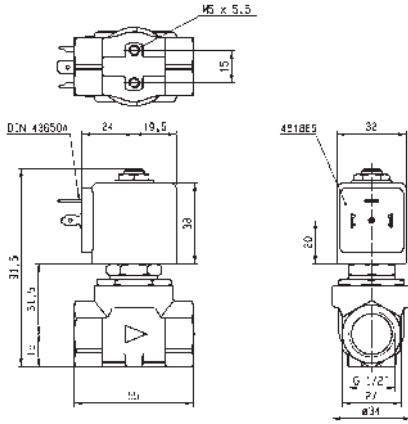

Drawing 3427

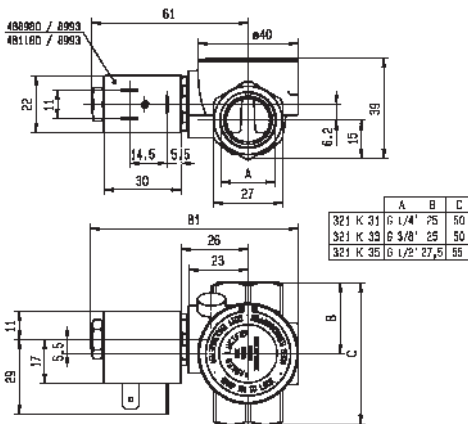

Drawing 7093

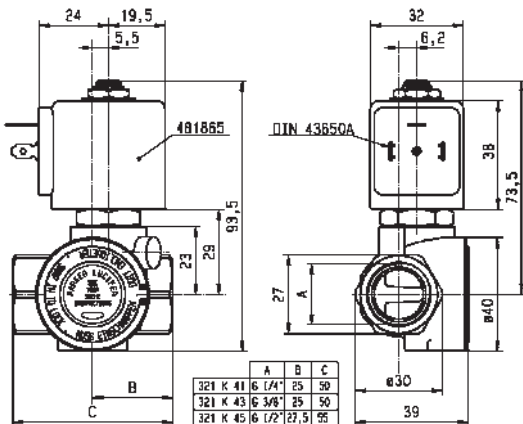

Drawing 7094

2/2

VALVES FOR WATER AND NEUTRAL LIQUIDS
PILOT OPERATED

BRASS

PIPE MOUNTING

NORMALLY CLOSED

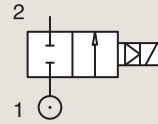

Port size	Orifice Ø	Flow factors			Operating Pressure Differential			Fluid Temp.		Seat Seal	Parker LUCIFER® Valves			Power		Coil Group	Dwg. No.
		Kv l/min	KV m³/h	Qn l/min	Min bar	Max(MOPD) AC bar	DC bar	Min °C	Max °C		Valve Ref.	Housing Ref.	Coil Ref.	AC W	DC W		
3/4"	18	100	6	9400	0.3	10	10	-10	100	NBR	321K36	8993	481180	4	5	1.1	7097
	18	100	6	9400	0.3	10	7	-10	75	NBR	321K36	8993	488980	2	2.5	1.1	7097
	18	100	6	9400	0.3	12	12	-10	100	FKM	321K4606	2995	481865	8	9	2.1/3.0	7099
	18	100	6	9400	0.3	12	12	-10	120	FKM	321K4606	4270	481000	8	8	2.1/3.0	7099
	18	100	6	9400	0.3	12	12	-10	100	FKM	321K4656 ₁	2995	481865	8	9	2.1/3.0	7099
	18	100	6	9400	0.3	12	12	-10	120	FKM	321K4656 ₁	4270	481000	8	8	2.1/3.0	7099
	20	135	8.1	9500	0.3	16	16	-10	100	NBR	E321G36	2995	481865	8	9	2.0	3442
	20	135	8.1	9500	0.3	16	16	-10	100	NBR	E321G36	4270	481000	8	8	2.0	3442

Notes:

1. With manual override



For this page	Port size	Orifice (mm)	Kv (l/min)	MOPD (bar)	Fluid Temp (°C)	Amb Temp (°C)
From	3/4"	18	100	7	-10	-10
To	3/4"	20	135	16	120	50

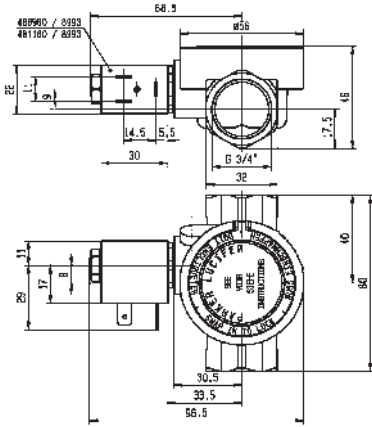

Drawing 7097

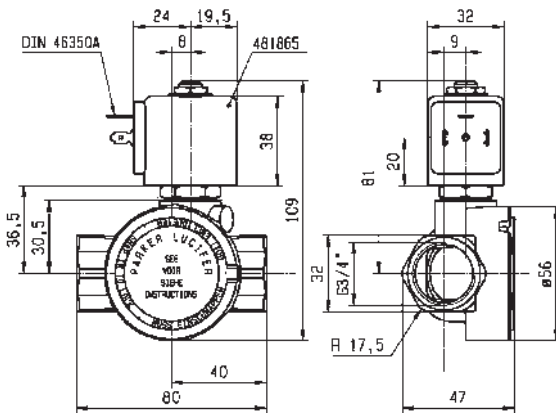

Drawing 7099

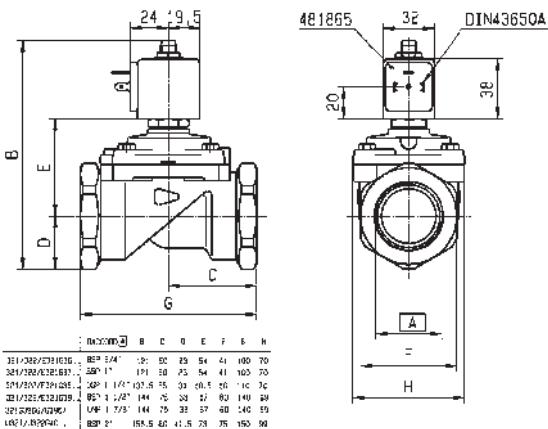

Drawing 3442

2/2

VALVES FOR WATER AND NEUTRAL LIQUIDS
PILOT OPERATED

BRASS

PIPE MOUNTING

NORMALLY CLOSED

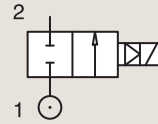

Port size	Orifice Ø	Flow factors			Operating Pressure Differential			Fluid Temp.		Seat Seal	Parker LUCIFER® Valves			Power		Coil Group	Dwg. No.
					Min	Max(MOPD)		Min	Max		Valve Ref.	Housing Ref.	Coil Ref.	AC W	DC W		
						bar	AC bar										
BSP	mm	Kv l/min	KV m³/h	Qn l/min	bar	AC bar	DC bar	°C	°C								
1"	18	110	6.6	10150	0.3	10	10	-10	100	NBR	321K37	8993	481180	4	5	1.1	7098
	18	110	6.6	10150	0.3	10	7	-10	75	NBR	321K37	8993	488980	2	2.5	1.1	7098
	18	110	6.6	10150	0.3	12	12	-10	100	FKM	321K4706	2995	481865	8	9	2.1/3.0	7100
	18	110	6.6	10150	0.3	12	12	-10	120	FKM	321K4706	4270	481000	8	8	2.1/3.0	7100
	18	110	6.6	10150	0.3	12	12	-10	100	FKM	321K4756 ₂	2995	481865	8	9	2.1/3.0	7100
	18	110	6.6	10150	0.3	12	12	-10	120	FKM	321K4756 ₂	4270	481000	8	8	2.1/3.0	7100
	25	180	10.8	14000	0.3	16	16	-10	100	NBR	E321G37	2995	481865	8	9	2.0	3442
	25	180	10.8	14000	0.3	16	16	-10	100	NBR	E321G37	4270	481000	8	8	2.0	3442
	28	270	16.2	18000	0.3	16	16	-10	100	NBR	E321G38	2995	481865	8	9	2.0	3442
28	270	16.2	18000	0.3	16	16	-10	100	NBR	E321G38	4270	481000	8	8	2.0	3442	
1 1/2"	40	420	25.2	31500	0.3	16	7	-10	100	NBR	E321G39 ₁	2995	481865	8	9	2.0	3442
	40	420	25.2	31500	0.3	16	8.5	-10	100	NBR	E321G39 ₁	4270	481000	8	8	2.0	3442
2"	40	540	32.4	40000	0.3	16	7	-10	100	NBR	E321G40 ₁	2995	481865	8	9	2.0	3442
	40	540	32.4	40000	0.3	16	8.5	-10	100	NBR	E321G40 ₁	4270	481000	8	8	2.0	3442

Notes:

1. Pilot seat disc in synthetic Ruby
2. With manual override



For this page	Port size	Orifice (mm)	Kv (l/min)	MOPD (bar)	Fluid Temp (°C)	Amb Temp (°C)
From	1"	18	110	7	-10	-10
To	2"	40	540	16	120	50

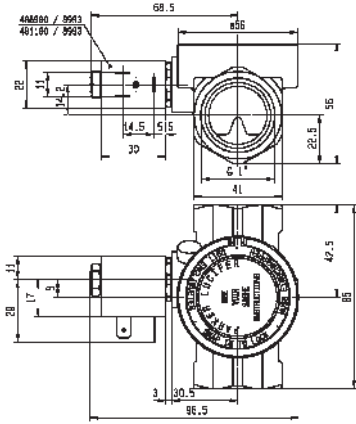

Drawing 7098

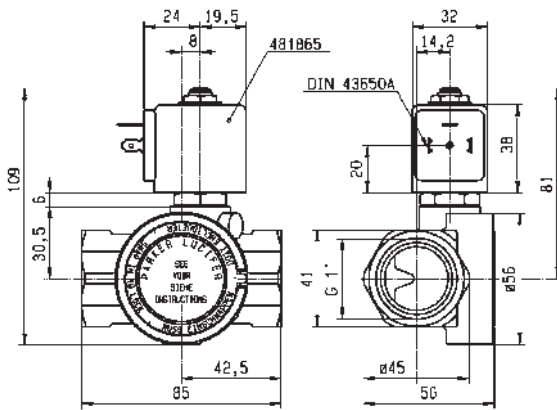

Drawing 7100

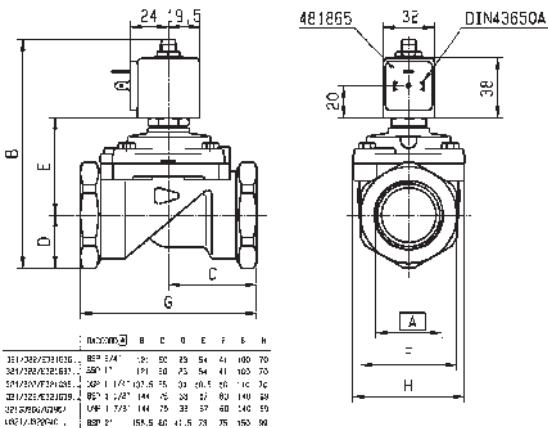

Drawing 3442

2/2

VALVES FOR WATER AND NEUTRAL LIQUIDS PILOT OPERATED

BRASS

PIPE MOUNTING

NORMALLY OPEN

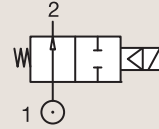

Port size	Orifice Ø	Flow factors			Operating Pressure Differential			Fluid Temp.		Seat Seal	Parker Valves			Power		Coil Group	Dwg. No.
					Min	Max(MOPD)	DC bar	Min	Max		Valve Order Number	Valve Type	Coil Type	AC W	DC W		
BSP	mm	Kv l/min	KV m³/h	Qn m³/h	bar	AC bar	DC bar	°C	°C		Valve Order Number	Valve Type	Coil Type	AC W	DC W		
3/8"	13	50	3	-	0.1	10	10	-10	140	EPDM	444600W	7322BIH00	481865	8	9	2.0	060
	13	50	3	-	0.1	20	20	-10	90	NBR	443805W	7322BIN00	481865	8	9	2.0	060
	13	50	3	-	0.1	20	20	-10	140	FKM	444499W	7322BIV00	481865	8	9	2.0	060
1/2"	13	50	3	-	0.1	10	10	-10	140	EPDM	444601W	7322BAH00	481865	8	9	2.0	060
	13	50	3	-	0.1	20	20	-10	90	NBR	443806W	7322BAN00	481865	8	9	2.0	060
	13	50	3	-	0.1	20	20	-10	140	FKM	444500W	7322BAV00	481865	8	9	2.0	060
3/4"	20	140	8.4	-	0.1	10	10	-10	140	EPDM	444602W	7322BCH00	481865	8	9	2.0	061
	20	140	8.4	-	0.1	20	20	-10	90	NBR	443807W	7322BCN00	481865	8	9	2.0	061
	20	140	8.4	-	0.1	20	20	-10	140	FKM	444501W	7322BCV00	481865	8	9	2.0	061
1"	25	160	9.6	-	0.1	10	10	-10	140	EPDM	444603W	7322BDH00	481865	8	9	2.0	061
	25	160	9.6	-	0.1	20	20	-10	90	NBR	443808W	7322BDN00	481865	8	9	2.0	061
	25	160	9.6	-	0.1	20	20	-10	140	FKM	444502W	7322BDV00	481865	8	9	2.0	061
1 1/4"	35	420	25.2	-	0.1	10	10	-10	140	EPDM	444576W	7322BEH00	481865	8	9	2.0	062
	35	420	25.2	-	0.1	10	10	-10	90	NBR	443809W	7322BEN00	481865	8	9	2.0	062
1 1/2"	40	500	30	-	0.1	10	10	-10	140	EPDM	444604W	7322BFH00	481865	8	9	2.0	062
	40	500	30	-	0.1	10	10	-10	90	NBR	443810W	7322BFN00	481865	8	9	2.0	062
2"	50	620	37.2	-	0.1	10	10	-10	140	EPDM	444605W	7322BGH00	481865	8	9	2.0	062
	50	620	37.2	-	0.1	10	10	-10	90	NBR	443811W	7322BGN00	481865	8	9	2.0	062
2 1/2"	65	1100	66	-	0.2	10	10	-10	90	NBR	444513W	7322BLN06	481865	8	9	2.0	063
3"	75	1334	80	-	0.2	10	10	-10	90	NBR	444503W	7322BMN06	481865	8	9	2.0	063

G	A		B		C	
NPT	mm	inch	mm	inch	mm	inch
1-1/4"	143	5.70	144.5	5.69	103	4.01
1-1/2"	143	—	134	—	102	—
2"	173	—	148	—	118	—

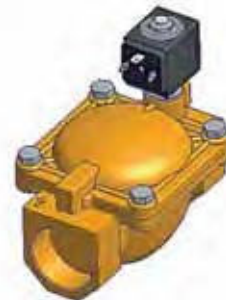
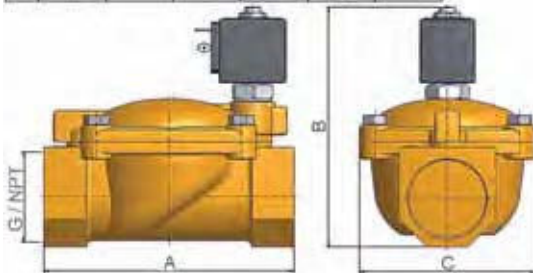

Drawing 062



For this page	Port size	Orifice (mm)	Kv (l/min)	MOPD (bar)	Fluid Temp (°C)	Amb Temp (°C)
From	3/8"	13	50	10	-10	-10
To	3"	75	1334	20	140	50

G	A		B		C	
NPT	mm	inch	mm	inch	mm	inch
3/8"	89	3.51	110	4.33	42	1.67
1/2"	72	2.83	122	4.81	49	1.93

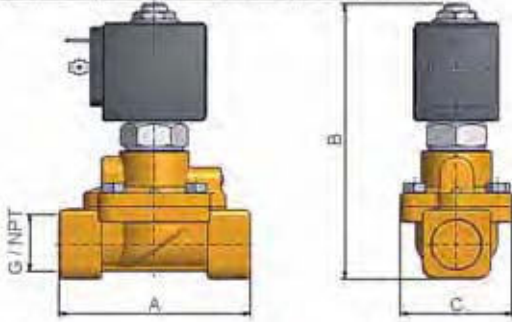

Drawing 060

G	A		B		C	
NPT	mm	inch	mm	inch	mm	inch
3/4"	109	3.93	117.5	4.62	65	2.55
1"	104	4.09	123	4.84	65	2.55

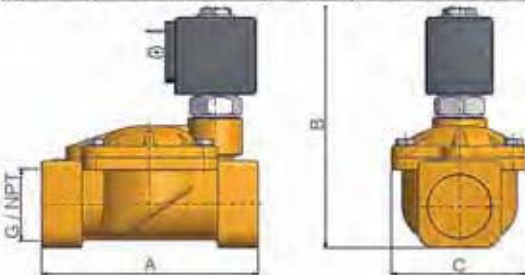

Drawing 061

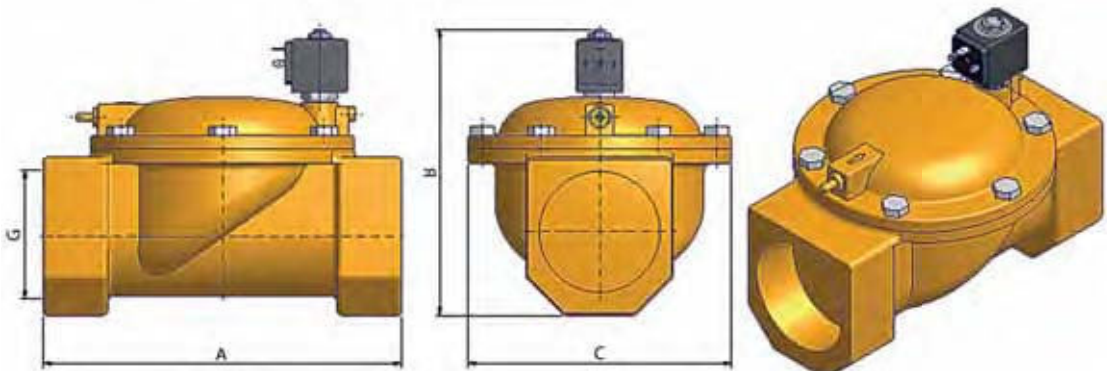

Drawing 063

2/2

VALVES FOR WATER AND NEUTRAL LIQUIDS PILOT OPERATED

BRASS

PIPE MOUNTING

NORMALLY OPEN

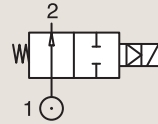

Port size	Orifice Ø	Flow factors			Operating Pressure Differential			Fluid Temp.		Seat Seal	Parker LUCIFER® Valves			Power		Coil Group	Dwg. No.
		Kv l/min	KV m³/h	Qn l/min	Min bar	Max(MOPD) AC bar	DC bar	Min °C	Max °C		Valve Ref.	Housing Ref.	Coil Ref.	AC W	DC W		
1/4"	12	32	1.92	2150	0.3	12	12	-10	100	FKM	322K4106	2995	481865	8	9	2.1	7094
	12	32	1.92	2150	0.3	12	12	-10	120	FKM	322K4106	4270	481000	8	8	2.1	7094
3/8"	12	45	2.7	3050	0.3	12	12	-10	100	FKM	322K4306	2995	481865	8	9	2.1	7094
	12	45	2.7	3050	0.3	12	12	-10	120	FKM	322K4306	4270	481000	8	8	2.1	7094
1/2"	12	50	3	3400	0.3	12	12	-10	100	FKM	322K4506	2995	481865	8	9	2.1	7094
	12	50	3	3400	0.3	12	12	-10	120	FKM	322K4506	4270	481000	8	8	2.1	7094
	15	60	3.6	3890	0.3	15	15	-10	100	NBR	322G75	2995	481865	8	9	2.1	3522
3/4"	15	60	3.6	3890	0.3	15	15	-10	100	NBR	322G75	4270	481000	8	8	2.1	3522
	18	100	6	9400	0.3	12	12	-10	100	FKM	322K4606	2995	481865	8	9	2.1	7099
	18	100	6	9400	0.3	12	12	-10	120	FKM	322K4606	4270	481000	8	8	2.1	7099
	20	135	8.1	9500	0.3	16	16	-10	100	NBR	322G36	2995	481865	8	9	2.1	3442
	20	135	8.1	9500	0.3	16	16	-10	100	NBR	322G36	4270	481000	8	8	2.1	3442

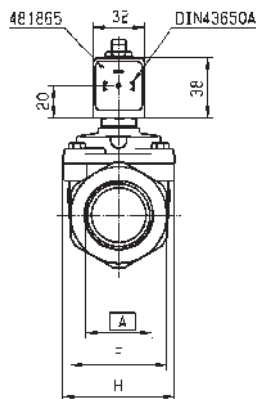
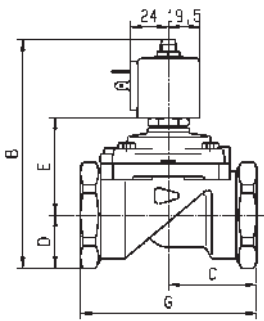

Part No.	Port Size	Orifice	Flow Factors	Operating Pressure	Fluid Temp.	Seat Seal	Valve Ref.	Housing Ref.	Coil Ref.	Power	Coil Group	Dwg. No.
321K38E/321K38E	3/4"	32	1.92	2150	-10 to 100	FKM	322K4106	2995	481865	8 9	2.1	7094
321K38E/321K38E	3/4"	32	1.92	2150	-10 to 120	FKM	322K4106	4270	481000	8 8	2.1	7094
321K45E/321K45E	3/8"	45	2.7	3050	-10 to 100	FKM	322K4306	2995	481865	8 9	2.1	7094
321K45E/321K45E	3/8"	45	2.7	3050	-10 to 120	FKM	322K4306	4270	481000	8 8	2.1	7094
321K50E/321K50E	1/2"	50	3	3400	-10 to 100	FKM	322K4506	2995	481865	8 9	2.1	7094
321K50E/321K50E	1/2"	50	3	3400	-10 to 120	FKM	322K4506	4270	481000	8 8	2.1	7094
321K60E/321K60E	1/2"	60	3.6	3890	-10 to 100	NBR	322G75	2995	481865	8 9	2.1	3522
321K60E/321K60E	1/2"	60	3.6	3890	-10 to 100	NBR	322G75	4270	481000	8 8	2.1	3522
321K100E/321K100E	3/4"	100	6	9400	-10 to 100	FKM	322K4606	2995	481865	8 9	2.1	7099
321K100E/321K100E	3/4"	100	6	9400	-10 to 120	FKM	322K4606	4270	481000	8 8	2.1	7099
321K135E/321K135E	3/4"	135	8.1	9500	-10 to 100	NBR	322G36	2995	481865	8 9	2.1	3442
321K135E/321K135E	3/4"	135	8.1	9500	-10 to 100	NBR	322G36	4270	481000	8 8	2.1	3442

Drawing 3442



For this page	Port size	Orifice (mm)	Kv (l/min)	MOPD (bar)	Fluid Temp (°C)	Amb Temp (°C)
From	1/4"	12	32	12	-10	-10
To	3/4"	20	135	16	120	50

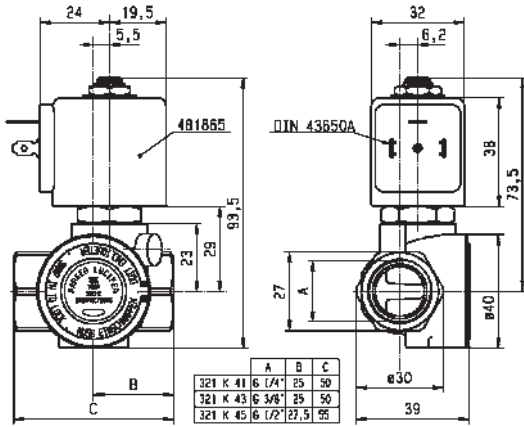

Drawing 7094

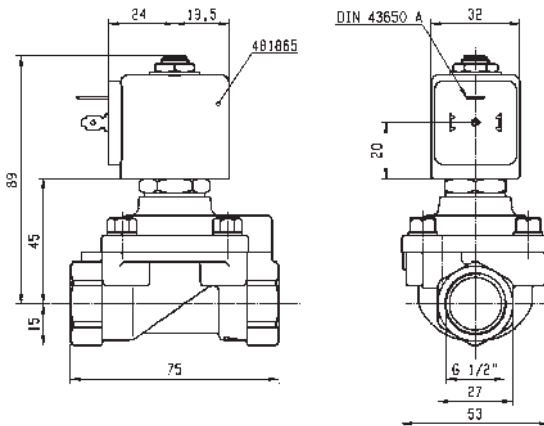

Drawing 3522

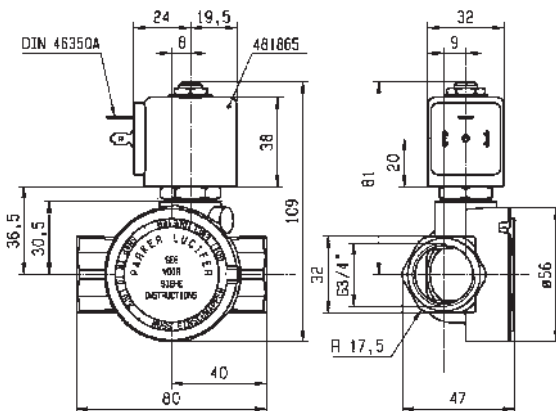

Drawing 7099

2/2

VALVES FOR WATER AND NEUTRAL LIQUIDS
PILOT OPERATED

BRASS

PIPE MOUNTING

NORMALLY OPEN

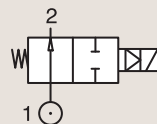

Port size	Orifice Ø	Flow factors			Operating Pressure Differential			Fluid Temp.		Seat Seal	Parker LUCIFER® Valves			Power		Coil Group	Dwg. No.
					Min	Max(MOPD)		Min	Max		Valve Ref.	Housing Ref.	Coil Ref.	AC W	DC W		
BSP	mm	Kv l/min	KV m³/h	Qn l/min	bar	AC bar	DC bar	°C	°C								
1"	18	110	6.6	10150	0.3	12	12	-10	100	FKM	322K4706	2995	481865	8	9	2.0	7100
	18	110	6.6	10150	0.3	12	12	-10	120	FKM	322K4706	4270	481000	8	8	2.0	7100
	25	180	10.8	14000	0.3	16	16	-10	100	NBR	322G37	2995	481865	8	9	2.1	3442
	25	180	10.8	14000	0.3	16	16	-10	100	NBR	322G37	4270	481000	8	8	2.1	3442
1 1/2"	40	420	25.2	31500	0.3	12	12	-10	100	NBR	322G39	2995	481865	8	9	2.1	3442
	40	420	25.2	31500	0.3	12	12	-10	100	NBR	322G39	4270	481000	8	8	2.1	3442

BRASS

SUB-BASE MOUNTING

NORMALLY CLOSED

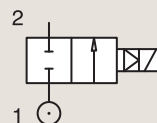

Port size	Orifice Ø	Flow factors			Operating Pressure Differential			Fluid Temp.		Seat Seal	Parker LUCIFER® Valves			Power		Coil Group	Dwg. No.
					Min	Max(MOPD)		Min	Max		Valve Ref.	Housing Ref.	Coil Ref.	AC W	DC W		
	mm	Kv l/min	KV m³/h	Qn l/min	bar	AC bar	DC bar	°C	°C								
SB	14	45	2.7	2100	0.3	40	25	-10	100	NBR	E321F32 ₁	2995	481865	8	9	2.0	3520
	14	45	2.7	2100	0.3	40	30	-10	100	NBR	E321F32 ₁	4270	481000	8	8	2.0	3520
	14	45	2.7	2100	0.3	40	40	-10	100	NBR	E321F32 ₁	4270	486265	14	14	2.0	3520

Notes:

1. Pilot seat disc in synthetic Ruby



For this page	Port size	Orifice (mm)	Kv (l/min)	MOPD (bar)	Fluid Temp (°C)	Amb Temp (°C)
From	14 mm	14	45	12	-10	-10
To	1 1/2"	40	420	40	120	50

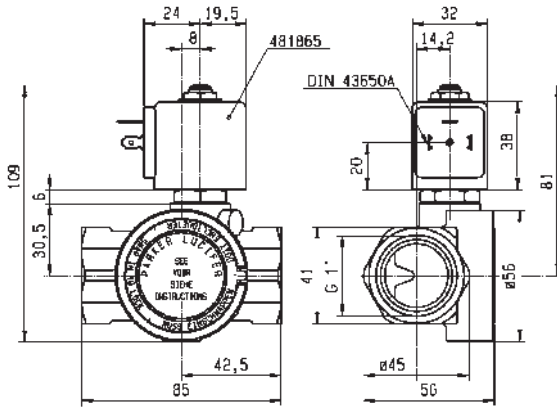

Drawing 7100

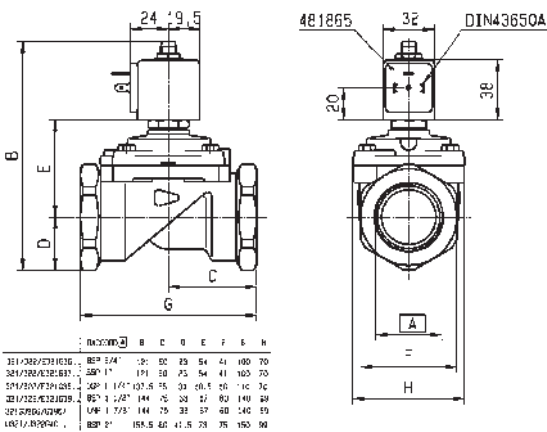

Drawing 3442

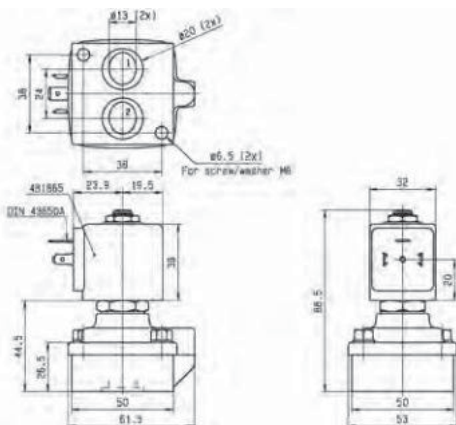

Drawing 3520

2 WAY VALVES

ANTI WATER HAMMER VALVES



2/2

Actuation	Body	Function	Port Size	Orifice (mm)	Flow Factor Kv(l/min)	MOPD (bar)	Max Fluid Temp. (°C)	Page Parker Valves	Page Parker LUCIFER® Valves
Magnalift	Brass/Pipe mounting	Normally Closed	1"	15 to 25	170	10	140	-	114
Pilot Operated	Brass/Pipe mounting	Normally Closed	1/4"	12	32	12	120	-	118
			3/8"	12	45	12	120	-	118
			1/2"	12	50	12	120	-	118
			3/4"	18 to 20	135	16	120	-	118
			1"	18 to 25	180	16	120	116	120
			1 1/4"	25 to 28	280	16	100	116	120
			1 1/2"	35 to 40	500	16	100	116	120
			2"	40 to 50	620	16	100	116	120
			2 1/2"	65	1100	10	90	116	-
			3"	75	1334	10	90	116	-
		Normally Open	3/4"	20	135	16	100	-	122
			1"	25	180	16	100	-	122
			1 1/4"	28	270	16	100	-	122
			1 1/2"	40	425	12	100	-	122
			2"	40	540	12	100	-	122

2/2

ANTI WATER HAMMER VALVES
MAGNALIFT

Commercial Equipment

BRASS
PIPE MOUNTING

NORMALLY CLOSED

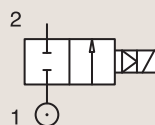

Port size	Orifice Ø	Flow factors			Operating Pressure Differential			Fluid Temp.		Seat Seal	Parker LUCIFER® Valves			Power		Coil Group	Dwg. No.
		Kv l/min	KV m³/h	Qn l/min	Min bar	Max(MOPD) AC bar	DC bar	Min °C	Max °C		Valve Ref.	Housing Ref.	Coil Ref.	AC W	DC W		
1"	15	80	4.8	6000	0	-	10	-10	100	NBR	221G1731 ¹²	2995	481865	-	9	2.1	3445
	15	80	4.8	6000	0	10	10	-10	120	NBR	221G1731 ¹²	-	492070	9	8	2.1	3445
	15	80	4.8	6000	0	10	10	-10	120	NBR	221G1731 ¹²	-	492190	11	9	2.1	3445
	25	160	9.6	-	0	10	-	0	100	EPDM	221G2103	2995	481865	8	-	2.0	3448
	25	160	9.6	-	0	10	-	0	120	EPDM	221G2103	4270	481000	8	-	2.0	3448
	25	160	9.6	-	0	10	10	0	120	EPDM	221G2103	4270	486265	14	14	2.0	3448
	25	160	9.6	-	0	4	4	0	140	EPDM	221G2103	2995	492425	14	14	2.0	3448
	25	170	10.2	14000	0	-	10	-10	100	NBR	221G2131 ¹²	2995	481865	-	9	2.1	3448
	25	170	10.2	14000	0	10	10	-25	40	NBR	221G2131 ¹²	-	492070	9	8	2.1	3448
	25	170	10.2	14000	0	10	10	-25	40	NBR	221G2131 ¹²	-	492190	11	9	2.1	3448

Notes:

1. Valves with model number ending in 30 or 31 are only compatible with explosion proof electrical parts shown, or with group 2.1 coils only in DC voltage.
2. With 4 position selector for controlled closure rate



For this page	Port size	Orifice (mm)	Kv (l/min)	MOPD (bar)	Fluid Temp (°C)	Amb Temp (°C)
From	1"	15	80	4	-25	-10
To	1"	25	170	10	140	50

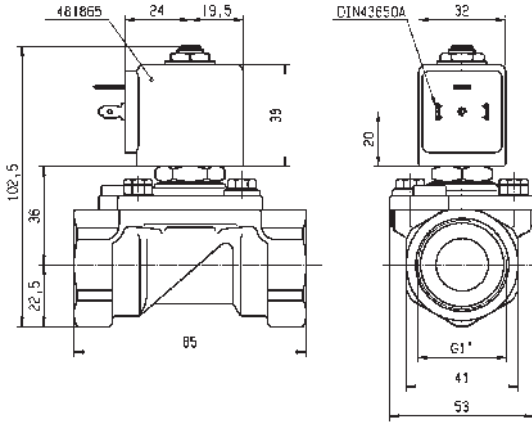

Drawing 3445

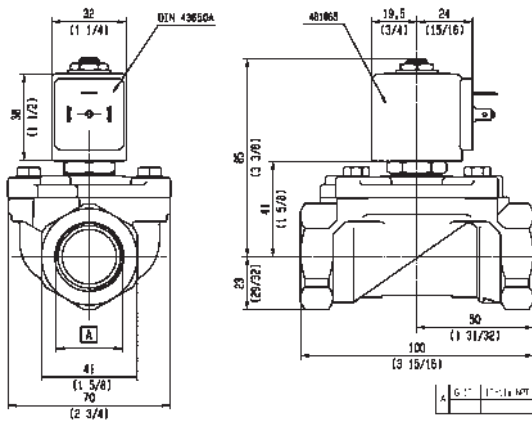

Drawing 3448

2/2

ANTI WATER HAMMER VALVES PILOT OPERATED



Commercial Equipment



Industrial Equipment



Medical / Instrumentation

BRASS PIPE MOUNTING

NORMALLY CLOSED

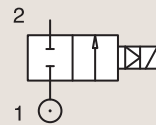

Port size	Orifice Ø	Flow factors			Operating Pressure Differential			Fluid Temp.		Seat Seal	Parker Valves			Power		Coil Group	Dwg. No.
		Kv l/min	KV m ³ /h	Qn m ³ /h	Min bar	Max(MOPD) AC bar	DC bar	Min °C	Max °C		Valve Order Number	Valve Type	Coil Type	AC W	DC W		
3/4"	20	140	8.4	-	0.1	10	10	-10	90	NBR	443784W ₁	7321BCN02	481865	8	9	2.0	057
1"	25	160	9.6	-	0.1	10	10	-10	90	NBR	443788W ₁	7321BDN02	481865	8	9	2.0	057
1 1/4"	35	420	25.2	-	0.1	5	5	-10	90	NBR	443792W ₁	7321BEN02	481865	8	9	2.0	058
1 1/2"	40	500	30	-	0.1	5	5	-10	90	NBR	443796W ₁	7321BFN02	481865	8	9	2.0	058
2"	50	620	37.2	-	0.1	5	5	-10	90	NBR	443800W ₁	7321BGN02	481865	8	9	2.0	058
2 1/2"	65	1100	66	-	0.2	10	10	-10	90	NBR	443802W ₁	7321BLN02	481865	8	9	2.0	059
3"	75	1334	80	-	0.2	10	10	-10	90	NBR	443803W ₁	7321BMN02	481865	8	9	2.0	059

Notes:

1. With manual override



For this page	Port size	Orifice (mm)	Kv (l/min)	MOPD (bar)	Fluid Temp (°C)	Amb Temp (°C)
From	1"	20	140	5	-10	-10
To	3"	75	1334	10	90	50

G	A		B		C	
NPT	mm	inch	mm	inch	mm	inch
3/4"	100	3.93	107	4.21	85	3.35
1"	104	4.09	112.5	4.42	85	3.35

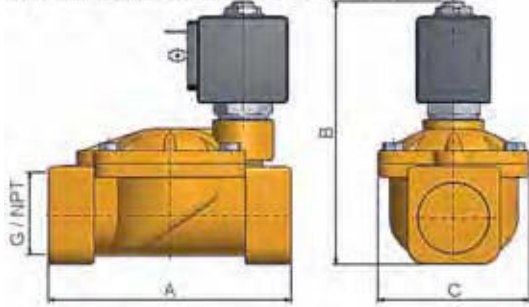

Drawing 057

G	A		B		C	
NPT	mm	inch	mm	inch	mm	inch
1-1/4"	140	5.51	134	5.27	102	4.01
1-1/2"	140	5.51	134	5.27	102	4.01
2"	173	6.81	148	5.82	118	4.64

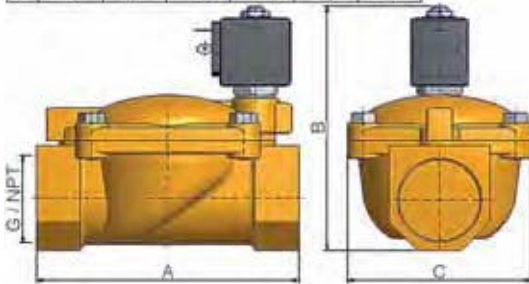

Drawing 058

G	A		B		C	
NPT	mm	inch	mm	inch	mm	inch
2-1/2"	245	9.65	195	7.68	184	7.24
3"	250	9.84	195	7.68	184	7.24

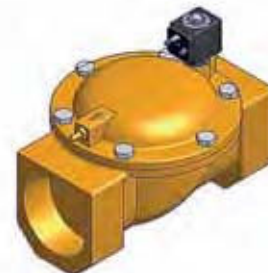
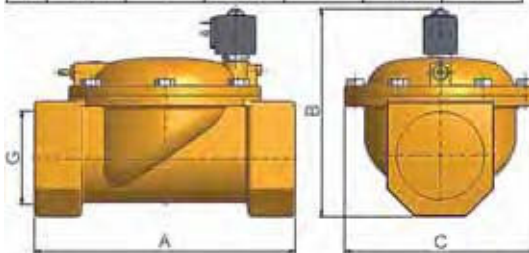

Drawing 059

2/2

ANTI WATER HAMMER VALVES PILOT OPERATED

BRASS

PIPE MOUNTING

NORMALLY CLOSED

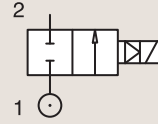

Port size	Orifice Ø	Flow factors			Operating Pressure Differential			Fluid Temp.		Seat Seal	Parker LUCIFER® Valves			Power		Coil Group	Dwg. No.
		Kv l/min	KV m ² /h	Qn l/min	Min bar	AC bar	DC bar	Min °C	Max °C		Valve Ref.	Housing Ref.	Coil Ref.	AC W	DC W		
1/4"	12	32	1.92	2150	0.3	12	12	-10	100	FKM	321K4106	2995	481865	8	9	2.1/3.0	7094
	12	32	1.92	2150	0.3	12	12	-10	120	FKM	321K4106	4270	481000	8	8	2.1/3.0	7094
3/8"	12	45	2.7	3050	0.3	12	12	-10	100	FKM	321K4306	2995	481865	8	9	2.1/3.0	7094
	12	45	2.7	3050	0.3	12	12	-10	120	FKM	321K4306	4270	481000	8	8	2.1/3.0	7094
1/2"	12	50	3	3400	0.3	12	12	-10	100	FKM	321K4506	2995	481865	8	9	2.1/3.0	7094
	12	50	3	3400	0.3	12	12	-10	120	FKM	321K4506	4270	481000	8	8	2.1/3.0	7094
	12	50	3	3400	0.3	12	12	-10	100	FKM	321K4556 ₁	2995	481865	8	9	2.1/3.0	7094
	12	50	3	3400	0.3	12	12	-10	120	FKM	321K4556 ₁	4270	481000	8	8	2.1/3.0	7094
3/4"	18	100	6	9400	0.3	12	12	-10	100	FKM	321K4606	2995	481865	8	9	2.1/3.0	7099
	18	100	6	9400	0.3	12	12	-10	120	FKM	321K4606	4270	481000	8	8	2.1/3.0	7099
	18	100	6	9400	0.3	12	12	-10	100	FKM	321K4656 ₁	2995	481865	8	9	2.1/3.0	7099
	18	100	6	9400	0.3	12	12	-10	120	FKM	321K4656 ₁	4270	481000	8	8	2.1/3.0	7099
	20	135	8.1	9500	0	16	16	-10	100	NBR	E321G3610 ₂	2995	481865	8	9	2.0	3442
	20	135	8.1	9500	0	16	16	-10	100	NBR	E321G3610 ₂	4270	481000	8	8	2.0	3442

Notes:

1. With manual override

2. With manual override and 4 position selector for controlled closure rate - without manual override and without 4 position selector on request: use same reference removing suffix '10', e.g. E321G36



For this page	Port size	Orifice (mm)	Kv (l/min)	MOPD (bar)	Fluid Temp (°C)	Amb Temp (°C)
From	1/4"	12	32	12	-10	-10
To	3/4"	20	135	16	120	50

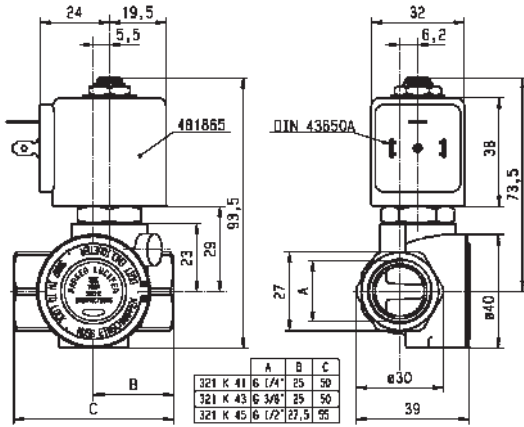

Drawing 7094

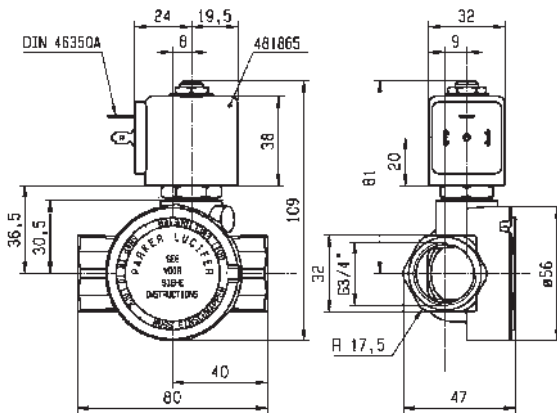

Drawing 7099

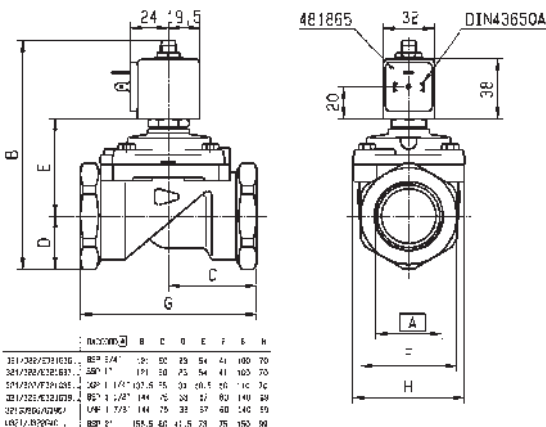

Drawing 3442

2/2

ANTI WATER HAMMER VALVES
PILOT OPERATED

BRASS

PIPE MOUNTING

NORMALLY CLOSED

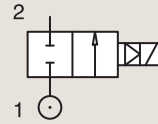

Port size	Orifice Ø	Flow factors			Operating Pressure Differential			Fluid Temp.		Seat Seal	Parker LUCIFER® Valves			Power		Coil Group	Dwg. No.
					Min	Max(MOPD)	DC bar	Min	Max		Valve Ref.	Housing Ref.	Coil Ref.	AC W	DC W		
BSP	mm	Kv l/min	KV m ² /h	Qn l/min	bar	AC bar	DC bar	°C	°C								
1"	18	110	6.6	10150	0.3	12	12	-10	100	FKM	321K4706	2995	481865	8	9	2.1/3.0	7100
	18	110	6.6	10150	0.3	12	12	-10	120	FKM	321K4706	4270	481000	8	8	2.1/3.0	7100
	18	110	6.6	10150	0.3	12	12	-10	100	FKM	321K4756 ₁	2995	481865	8	9	2.1/3.0	7100
	18	110	6.6	10150	0.3	12	12	-10	120	FKM	321K4756 ₁	4270	481000	8	8	2.1/3.0	7100
	25	180	10.8	14000	0.3	16	16	-10	100	NBR	E321G3710 ₂	2995	481865	8	9	2.0	3442
	25	180	10.8	14000	0.3	16	16	-10	100	NBR	E321G3710 ₂	4270	481000	8	8	2.0	3442
1 1/4"	28	280	16.8	18000	0.3	16	16	-10	100	NBR	E321G3810 ₂	2995	481865	8	9	2.0	3442
	28	280	16.8	18000	0.3	16	16	-10	100	NBR	E321G3810 ₂	4270	481000	8	8	2.0	3442
1 1/2"	40	420	25.2	31500	0.3	16	7	-10	100	NBR	E321G3910 ₂	2995	481865	8	9	2.0	3442
	40	420	25.2	31500	0.3	16	8.5	-10	100	NBR	E321G3910 ₂	4270	481000	8	8	2.0	3442
2"	40	540	32.4	40000	0.3	16	7	-10	100	NBR	E321G4010 ₂	2995	481865	8	9	2.0	3442
	40	540	32.4	40000	0.3	16	8.5	-10	100	NBR	E321G4010 ₂	4270	481000	8	8	2.0	3442

Notes:

1. With manual override

2. With manual override and 4 position selector for controlled closure rate - without manual override and without 4 position selector on request: use same reference removing suffix '10', e.g. E321G36



For this page	Port size	Orifice (mm)	Kv (l/min)	MOPD (bar)	Fluid Temp (°C)	Amb Temp (°C)
From	1"	18	110	7	-10	-10
To	2"	40	540	16	120	50

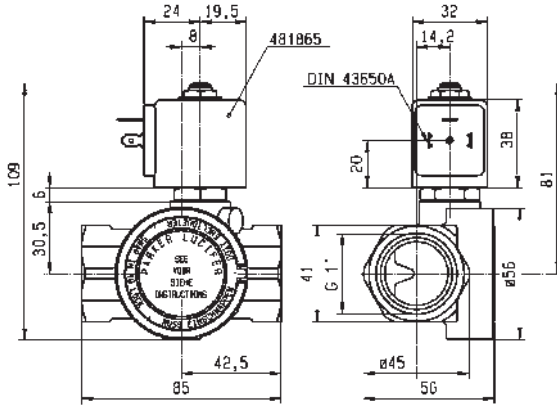

Drawing 7100

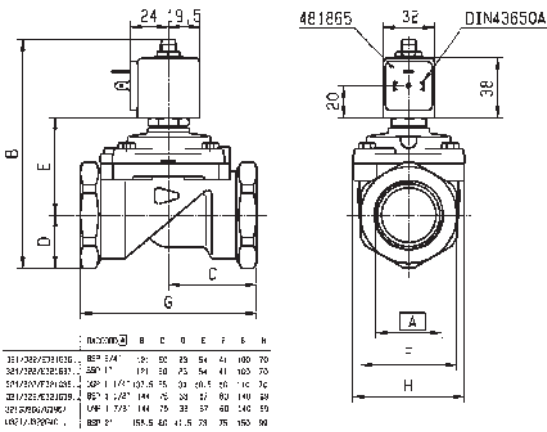

Drawing 3442

2/2

ANTI WATER HAMMER VALVES PILOT OPERATED

BRASS

PIPE MOUNTING

NORMALLY OPEN

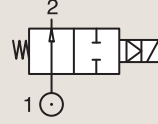

Port size	Orifice Ø	Flow factors			Operating Pressure Differential			Fluid Temp.		Seat Seal	Parker LUCIFER® Valves			Power		Coil Group	Dwg. No.
					Min	Max(MOPD)		Min	Max		Valve Ref.	Housing Ref.	Coil Ref.	AC W	DC W		
						bar	AC bar										
3/4"	20	135	8.1	9300	0.3	16	16	-10	100	NBR	322G3610 ₁	2995	481865	8	9	2.1	3442
	20	135	8.1	9300	0.3	16	16	-10	100	NBR	322G3610 ₁	4270	481000	8	8	2.1	3442
1"	25	180	10.8	14000	0.3	16	16	-10	100	NBR	322G3710 ₁	2995	481865	8	9	2.1	3442
	25	180	10.8	14000	0.3	16	16	-10	100	NBR	322G3710 ₁	4270	481000	8	8	2.1	3442
1 1/4"	28	270	16.2	18000	0.3	16	16	-10	100	NBR	322G3810 ₁	2995	481865	8	9	2.1	3442
	28	270	16.2	18000	0.3	16	16	-10	100	NBR	322G3810 ₁	4270	481000	8	8	2.1	3442
1 1/2"	40	425	25.5	31000	0.3	12	12	-10	100	NBR	322G3910 ₁	2995	481865	8	9	2.1	3442
	40	425	25.5	31000	0.3	12	12	-10	100	NBR	322G3910 ₁	4270	481000	8	8	2.1	3442
2"	40	540	32.4	40000	0.3	12	12	-10	100	NBR	322G4010 ₁	2995	481865	8	9	2.1	3442
	40	540	32.4	40000	0.3	12	12	-10	100	NBR	322G4010 ₁	4270	481000	8	8	2.1	3442

Notes:

1. With 4 position selector for controlled closure rate



For this page	Port size	Orifice (mm)	Kv (l/min)	MOPD (bar)	Fluid Temp (°C)	Amb Temp (°C)
From	3/4"	20	135	12	-10	-10
To	2"	40	540	16	100	50

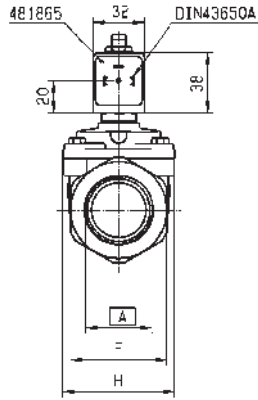
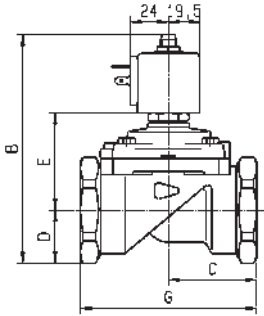

Part No.	Port Size	B	C	D	E	F	G	H
3E1/3E2/3E3/3E1036	3/4"	20	20	23	54	41	100	70
3E1/3E2/3E3/3E1037	1"	25	25	28	54	41	105	70
3E1/3E2/3E3/3E1038	1 1/4"	32	32	35	54	41	110	70
3E1/3E2/3E3/3E1039	1 1/2"	38	38	41	54	41	115	70
3E1/3E2/3E3/3E1040	2"	48	48	51	54	41	120	70

Drawing 3442

2 WAY VALVES

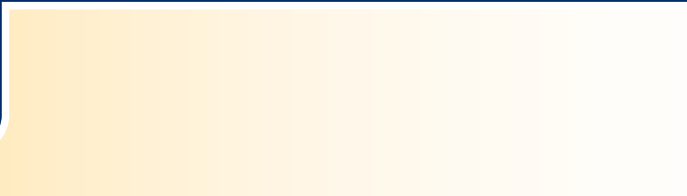

HOT WATER AND STEAM VALVES



Steam



Water

2/2

Actuation	Body	Function	Port Size	Orifice (mm)	Flow Factor Kv(l/min)	MOPD (bar)	Max Fluid Temp. (°C)	Page Parker Valves	Page Parker LUCIFER® Valves
Direct Operated	Brass/Pipe mounting	Normally Closed	1/8"	2.5	3.2	30	140	126	-
			1/4"	2.5 to 5	11	30	180	126	128
			3/8"	6	12	5	140	-	128
			1/2"	8.5 to 11	36	4	120	-	128
	303 Stainless St./Pipe mounting	Normally Closed	1/4"	1.5 to 5	10	100	180	-	130
Magnalift	Brass/Pipe mounting	Normally Closed	3/8"	15	65	10	140	-	132
			1/2"	15	65	10	140	-	132
			3/4"	15	80	10	140	-	132
			1"	15	80	10	140	-	132
Pilot Operated	Brass/Pipe mounting	Normally Closed	3/8"	10 to 16	78	16	180	134	-
			1/2"	10 to 16	78	16	180	134	138
			3/4"	18 to 27	193	14	180	136	-
			1"	18 to 27	193	14	180	136	-

2/2

HOT WATER AND STEAM VALVES DIRECT OPERATED



Commercial Equipment



Industrial Equipment



Medical / Instrumentation

BRASS PIPE MOUNTING

NORMALLY CLOSED

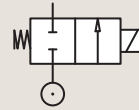

Port size	Orifice Ø	Flow factors			Operating Pressure Differential			Fluid Temp.		Seat Seal	Parker Valves			Power		Coil Group	Dwg. No.
		Kv	KV	Qn	Min	Max(MOPD)	Min	Max	Valve Order Number		Valve Type	Coil Type	AC W	DC W			
BSP	mm	l/min	m³/h	m³/h	bar	AC bar	DC bar	°C	°C								
1/8"	2.5	3.2	0.20	-	0	30	-	-30	140	Ruby	362496J	PM140IR	ZB09	9	-	20.1/20.2	027
	2.5	3.2	0.20	-	0	-	17	-30	140	Ruby	362496J	PM140IR	ZB12	-	12	20.1/20.2	027
	2.5	3.2	0.20	-	0	30	-	-30	140	Ruby	362518J ₁	PM140CR	ZB09	9	-	20.1/20.2	026
	2.5	3.2	0.20	-	0	-	17	-30	140	Ruby	362518J ₁	PM140CR	ZB12	-	12	20.1/20.2	026
	2.5	3.2	0.20	-	0	30	-	-30	140	Ruby	362518J ₁	PM140CR	ZH14	14	-	20.1/20.2	026
	2.5	3.2	0.20	-	0	-	17	-30	140	Ruby	362518J ₁	PM140CR	ZH16	-	16	20.1/20.2	026
1/4"	3	4.2	0.25	-	0	10	-	-10	140	EPDM	360470 ₂	PM126YH	ZB09	9	-	20.1/20.2	008
	3	4.2	0.25	-	0	-	6	-10	140	EPDM	360470 ₂	PM126YH	ZB12	-	12	20.1/20.2	008
	3	4.2	0.25	-	0	10	-	-10	140	EPDM	360470 ₂	PM126YH	ZH14	14	-	20.1/20.2	008
	3	4.2	0.25	-	0	-	6	-10	140	EPDM	360470 ₂	PM126YH	ZH16	-	16	20.1/20.2	008
	3	4.2	0.25	-	0	10	-	-10	180	PTFE	360475 ₂	PM126YT	ZH14	14	-	20.1/20.2	008
	3	4.2	0.25	-	0	-	10	-10	180	PTFE	360475 ₂	PM126YT	ZH16	-	16	20.1/20.2	008
	3	4	0.24	-	0	30	-	-30	140	Ruby	362524J	PM140DR	ZB09	9	-	20.1/20.2	026
	3	4	0.24	-	0	-	12	-30	140	Ruby	362524J	PM140DR	ZB12	-	12	20.1/20.2	026
	3	4	0.24	-	0	30	-	-30	140	Ruby	362524J	PM140DR	ZH14	14	-	20.1/20.2	026
	3	4	0.24	-	0	-	12	-30	140	Ruby	362524J	PM140DR	ZH16	-	16	20.1/20.2	026
	3	3.3	0.2	-	0	10	-	-10	140	EPDM	364880J ₂	PM158IH	ZH14	14	-	20.2	042
	3	3.3	0.2	-	0	-	4	-10	140	EPDM	364880J ₂	PM158IH	ZH16	-	16	20.2	042
	3	3.3	0.2	-	0	10	-	-10	180	PTFE	364884J ₂	PM158IT	ZH14	14	-	20.2	042
	3	3.3	0.2	-	0	-	10	-10	180	PTFE	364884J ₂	PM158IT	ZH16	-	16	20.2	042

Notes:

1. DIN-EN-ISO 23553-1 (2009-10) approved for oil burners
2. Maximum pressure for steam: 4 Bar (140°C)



For this page	Port size	Orifice (mm)	Kv (l/min)	MOPD (bar)	Fluid Temp (°C)	Amb Temp (°C)
From	1/8"	2.5	3.2	4	-30	-10
To	1/4"	3	4.2	30	180	50

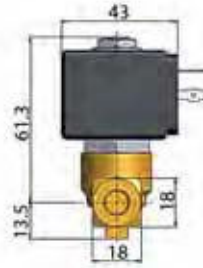
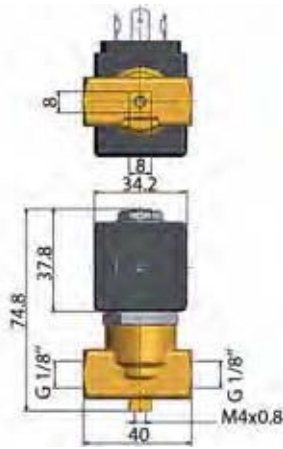

Drawing 027

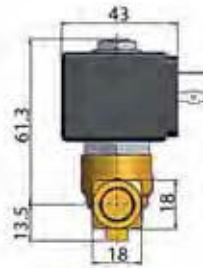
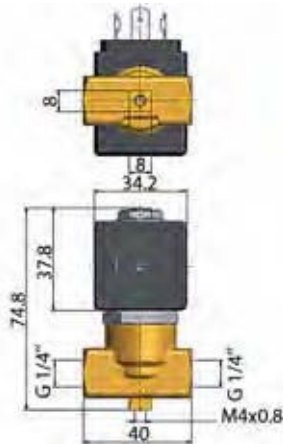

Drawing 026

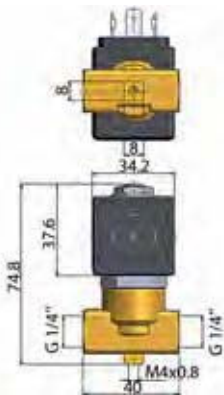

Drawing 008

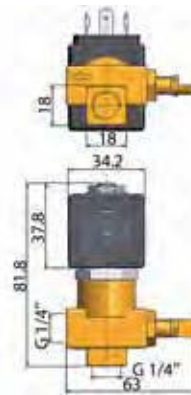

Drawing 042

2/2

HOT WATER AND STEAM VALVES

DIRECT OPERATED

BRASS

PIPE MOUNTING

NORMALLY CLOSED

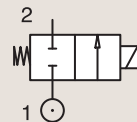

Port size	Orifice Ø	Flow factors			Operating Pressure Differential			Fluid Temp.		Seat Seal	Parker LUCIFER® Valves			Power		Coil Group	Dwg. No.
		Kv l/min	KV m³/h	Qn l/min	Min bar	Max(MOPD) AC bar	DC bar	Min °C	Max °C		Valve Ref.	Housing Ref.	Coil Ref.	AC W	DC W		
1/4"	3	4.5	0.27	-	0	10	7	0	100	EPDM	121K0323	2995	481865	8	9	2.0	3510
	3	4.5	0.27	-	0	10	8.5	0	120	EPDM	121K0323	4270	481000	8	8	2.0	3510
	3	4.5	0.27	-	0	10	10	0	120	EPDM	121K0323	4270	486265	14	14	2.0	3510
	3	4.5	0.27	-	0	10	10	0	120	EPDM	121K0323	2995	492425	14	14	2.0	3510
	5	11	0.66	750	0	7	2	0	100	EPDM	121K0103	2995	481865	8	9	2.0	3510
	5	11	0.66	750	0	7	2.8	0	120	EPDM	121K0103	4270	481000	8	8	2.0	3510
	5	11	0.66	750	0	7	5	0	120	EPDM	121K0103	4270	486265	14	14	2.0	3510
	5	11	0.66	750	0	4	3.5	0	120	EPDM	121K0103	2995	492425	14	14	2.0	3510
3/8"	5	11	0.66	750	0	7	2	0	100	EPDM	121K0113	2995	481865	8	9	2.0	3510
	6	12	0.72	1100	0	5	1.1	0	100	EPDM	121K3303	2995	481865	8	9	2.0	3551
	6	12	0.72	1100	0	5	1.5	0	120	EPDM	121K3303	4270	481000	8	8	2.0	3551
	6	12	0.72	1100	0	4	4	0	120	EPDM	121K3303	4270	486265	14	14	2.0	3551
1/2"	6	12	0.72	1100	0	4	4	0	140	EPDM	121K3303	2995	492425	14	14	2.0	3551
	8.5	25	1.5	-	0	2.2	0.5	0	120	EPDM	E121K4603	4270	481000	8	8	2.0	3427
	8.5	25	1.5	-	0	4	1.2	0	120	EPDM	E121K4603	4270	486265	14	14	2.0	3427
	8.5	25	1.5	-	0	4	1	0	120	EPDM	E121K4603	2995	492425	14	14	2.0	3427
	11	36	2.16	-	0	1.2	0.35	0	120	EPDM	E121K4503	4270	481000	8	8	2.0	3427
	11	36	2.16	-	0	2.5	0.7	0	120	EPDM	E121K4503	4270	486265	14	14	2.0	3427
11	36	2.16	-	0	2.5	0.5	0	120	EPDM	E121K4503	2995	492425	14	14	2.0	3427	



For this page	Port size	Orifice (mm)	Kv (l/min)	MOPD (bar)	Fluid Temp (°C)	Amb Temp (°C)
From	1/4"	3	4.5	0.4	0	-10
To	1/2"	11	36	10	140	50

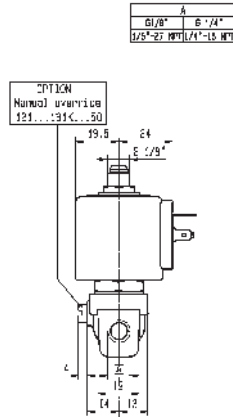
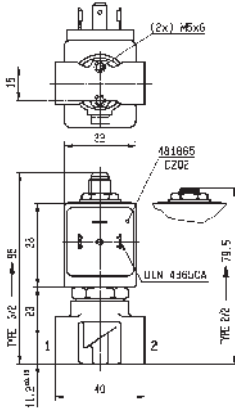

Drawing 3510

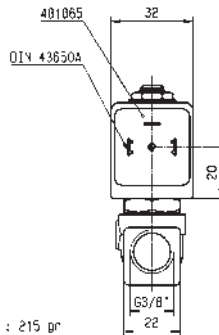
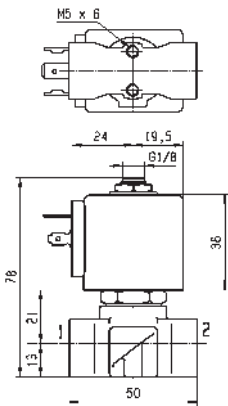

WEIGHT : 215 gr



Drawing 3551

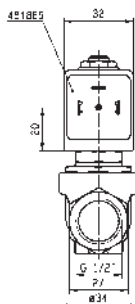
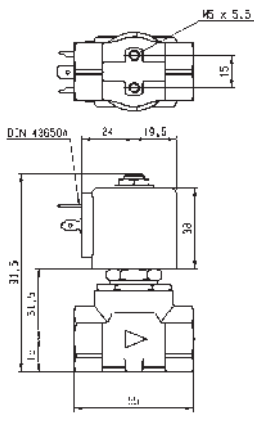

Drawing 3427

2/2

HOT WATER AND STEAM VALVES

DIRECT OPERATED

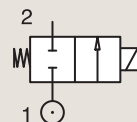
303 STAINLESS ST.
PIPE MOUNTING

NORMALLY CLOSED

Port size	Orifice Ø	Flow factors			Operating Pressure Differential			Fluid Temp.		Seat Seal	Parker LUCIFER® Valves			Power		Coil Group	Dwg. No.
		Kv l/min	KV m³/h	Qn l/min	Min bar	Max(MOPD) AC bar	DC bar	Min °C	Max °C		Valve Ref.	Housing Ref.	Coil Ref.	AC W	DC W		
1/4"	1.5	1.5	0.09	80	0	60	25	0	100	Ruby	121V5463	2995	481865	8	9	2.0	8116
	1.5	1.5	0.09	80	0	75	30	0	130	Ruby	121V5463	4270	481000	8	8	2.0	8116
	1.5	1.5	0.09	80	0	100	55	0	140	Ruby	121V5463	4270	486265	14	14	2.0	8116
	2.5	3.5	0.21	220	0	28	10	0	100	Ruby	121V5763	2995	481865	8	9	2.0	8116
	2.5	3.5	0.21	220	0	34	12	0	130	Ruby	121V5763	4270	481000	8	8	2.0	8116
	2.5	3.5	0.21	220	0	50	22	0	140	Ruby	121V5763	4270	486265	14	14	2.0	8116
	3	4.5	0.27	315	0	20	7	0	100	Ruby	121V5363	2995	481865	8	9	2.0	8116
	3	4.5	0.27	315	0	25	8.5	0	130	Ruby	121V5363	4270	481000	8	8	2.0	8116
	3	4.5	0.27	315	0	36	15	0	140	Ruby	121V5363	4270	486265	14	14	2.0	8116
	4	7	0.42	450	0	12	4	0	100	Ruby	121V5263	2995	481865	8	9	2.0	8116
	4	7	0.42	450	0	15	5	0	130	Ruby	121V5263	4270	481000	8	8	2.0	8116
	4	7	0.42	450	0	22	10	0	180	Ruby	121V5263	4270	486265	14	14	2.0	8116
	5	10	0.6	750	0	8.5	2	0	100	Ruby	121V5163	2995	481865	8	9	2.0	8116
	5	10	0.6	750	0	10	3.5	0	130	Ruby	121V5163	4270	481000	8	8	2.0	8116
5	10	0.6	750	0	14	6.5	0	140	Ruby	121V5163	4270	486265	14	14	2.0	8116	



For this page	Port size	Orifice (mm)	Kv (l/min)	MOPD (bar)	Fluid Temp (°C)	Amb Temp (°C)
From	1/4"	1.5	1.5	2	0	-10
To	1/4"	5	10	100	180	50

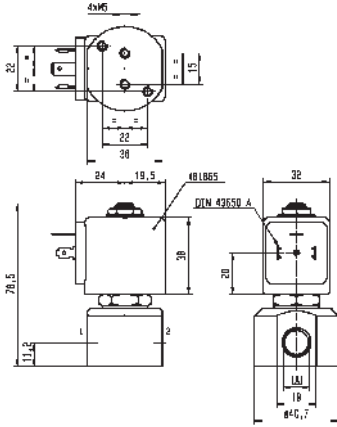

A	G 1/8"
	G 1/4"



Drawing 8116

2/2

HOT WATER AND STEAM VALVES MAGNALIFT



Commercial Equipment



Industrial Equipment



Medical / Instrumentation

BRASS PIPE MOUNTING

NORMALLY CLOSED

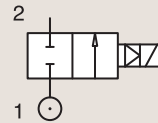

Port size	Orifice Ø	Flow factors			Operating Pressure Differential			Fluid Temp.		Seat Seal	Parker LUCIFER® Valves			Power		Coil Group	Dwg. No.
		Kv l/min	KV m³/h	Qn l/min	Min bar	Max(MOPD) AC bar	DC bar	Min °C	Max °C		Valve Ref.	Housing Ref.	Coil Ref.	AC W	DC W		
3/8"	15	65	3.9	-	0	10	-	0	100	EPDM	221G1303	2995	481865	8	-	2.0	3732
	15	65	3.9	-	0	10	-	0	120	EPDM	221G1303	4270	481000	8	-	2.0	3732
	15	65	3.9	-	0	4	4	0	140	EPDM	221G1303	4270	486265	14	14	2.0	3732
	15	65	3.9	4500	0	10	10	-10	100	FKM	221G1330 ₁	2995	481865	8	9	2.1	3732
	15	65	3.9	4500	0	10	10	-10	120	FKM	221G1330 ₁	-	492070	9	8	2.1	3732
	15	65	3.9	4500	0	10	10	-10	120	FKM	221G1330 ₁	-	492190	11	9	2.1	3732
1/2"	15	65	3.9	-	0	10	-	0	100	EPDM	221G1503	2995	481865	8	-	2.0	3732
	15	65	3.9	-	0	10	-	0	120	EPDM	221G1503	4270	481000	8	-	2.0	3732
	15	65	3.9	-	0	10	7	0	140	EPDM	221G1503	4270	486265	14	14	2.0	3732
3/4"	15	80	4.8	-	0	10	-	0	100	EPDM	221G1603	2995	481865	8	-	2.0	3444
	15	80	4.8	-	0	10	-	0	120	EPDM	221G1603	4270	481000	8	-	2.0	3444
	15	80	4.8	-	0	4	4	0	140	EPDM	221G1603	4270	486265	14	14	2.0	3444
1"	15	80	4.8	-	0	10	-	0	100	EPDM	221G1703	2995	481865	8	-	2.0	3445
	15	80	4.8	-	0	10	-	0	120	EPDM	221G1703	4270	481000	8	-	2.0	3445
	15	80	4.8	-	0	10	10	0	140	EPDM	221G1703	4270	486265	14	14	2.0	3445

Notes:

1. Valves with model number ending in 30 or 31 are only compatible with explosion proof electrical parts shown, or with group 2.1 coils only in DC voltage.



For this page	Port size	Orifice (mm)	Kv (l/min)	MOPD (bar)	Fluid Temp (°C)	Amb Temp (°C)
From	3/8"	15	65	4	-10	-10
To	1"	15	80	10	140	50

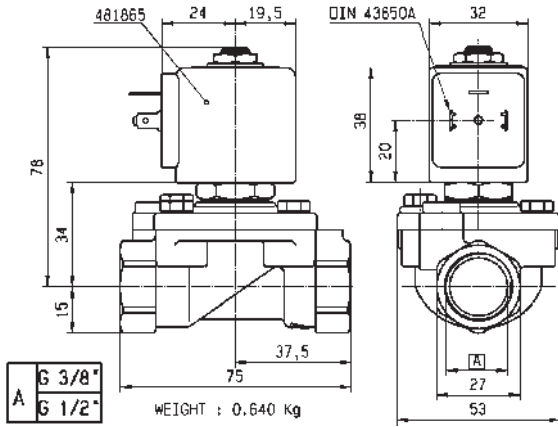

Drawing 3732

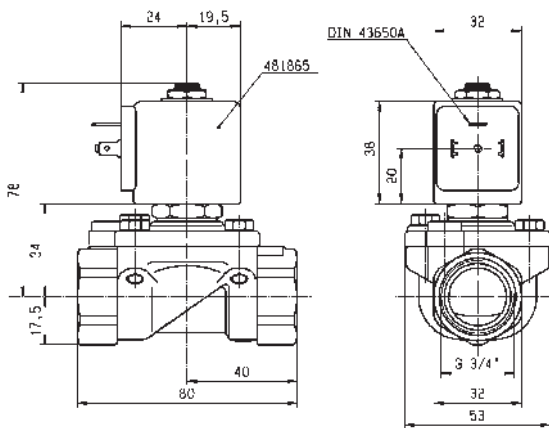

Drawing 3444

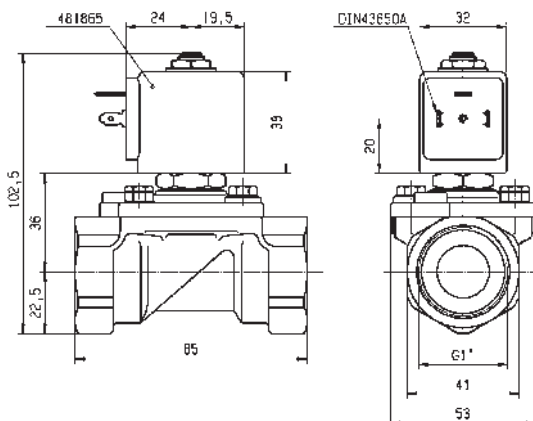

Drawing 3445

2/2

HOT WATER AND STEAM VALVES
PILOT OPERATED

Commercial Equipment



Industrial Equipment



Medical / Instrumentation

BRASS
PIPE MOUNTING

NORMALLY CLOSED

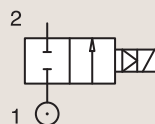

Port size	Orifice Ø	Flow factors			Operating Pressure Differential			Fluid Temp.		Seat Seal	Parker Valves			Power		Coil Group	Dwg. No.
		Kv l/min	KV m³/h	Qn m³/h	Min bar	Max(MOPD) AC bar	DC bar	Min °C	Max °C		Valve Order Number	Valve Type	Coil Type	AC W	DC W		
3/8"	10	22	1.32	-	0.5	16	-	-30	160	PTFE	364520 ¹	PM156.2IR	ZB09	9	-	20.1	041
	16	78	4.7	-	0.5	10	-	-30	180	PTFE	362262	PM135IT	ZH14	14	-	20.2	017
	16	78	4.7	-	0.5	-	10	-30	180	PTFE	362262	PM135IT	ZH16	-	16	20.2	017
1/2"	16	78	4.7	-	0.5	10	-	-30	180	PTFE	362263	PM135AT	ZH14	14	-	20.2	016
	16	78	4.7	-	0.5	-	10	-30	180	PTFE	362263	PM135AT	ZH16	-	16	20.2	016

Notes:

1. Maximum pressure for steam: 6.5 Bar (160°C)



For this page	Port size	Orifice (mm)	Kv (l/min)	MOPD (bar)	Fluid Temp (°C)	Amb Temp (°C)
From	3/8"	10	22	10	-30	-10
To	1/2"	16	78	16	180	50

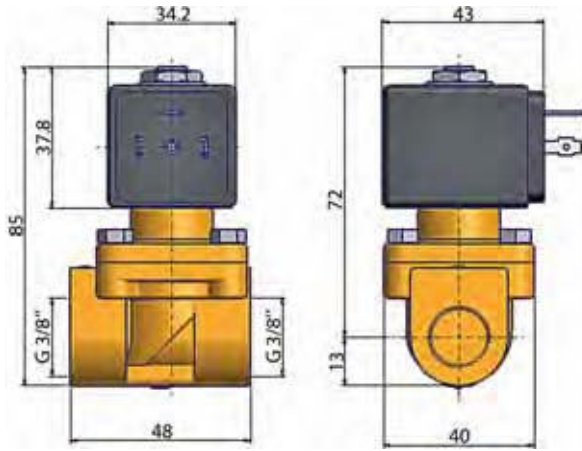

Drawing 041

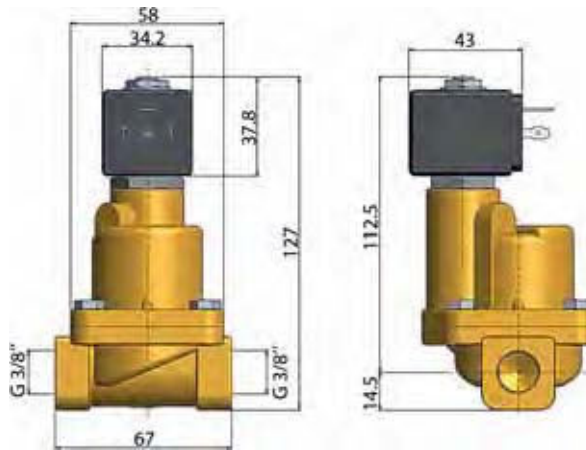

Drawing 017

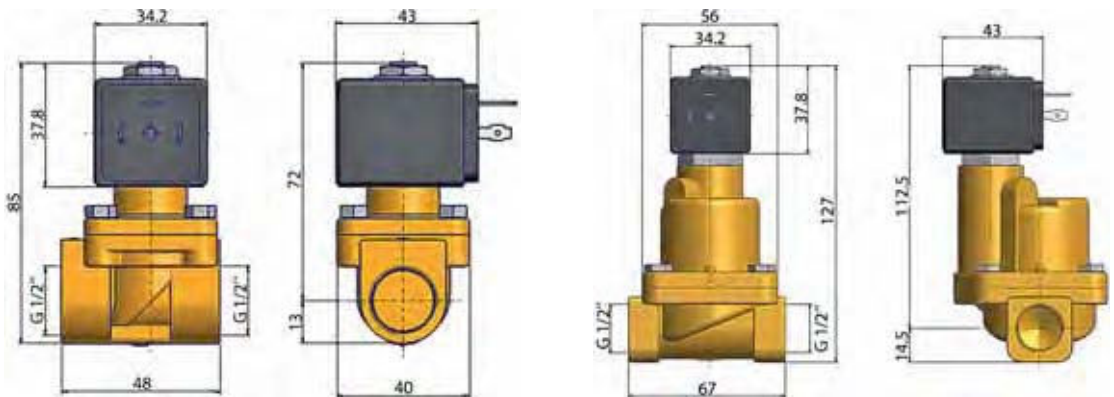

Drawing 038

Drawing 016

2/2

HOT WATER AND STEAM VALVES
PILOT OPERATED

BRASS

PIPE MOUNTING

NORMALLY CLOSED

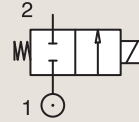

Port size	Orifice Ø	Flow factors			Operating Pressure Differential			Fluid Temp.		Seat Seal	Parker Valves			Power		Coil Group	Dwg. No.
		Kv l/min	KV m³/h	Qn m³/h	Min bar	Max(MOPD) AC bar	DC bar	Min °C	Max °C		Valve Order Number	Valve Type	Coil Type	AC W	DC W		
3/4"	18	37	2.22	-	0.5	14	-	-30	160	PTFE	364530 ₁	PM156.2CR	ZB09	9	-	20.1	039
	27	193	11.6	-	0.5	10	-	-30	180	PTFE	362264	PM135CT	ZH14	14	-	20.2	018
	27	193	11.6	-	0.5	-	10	-30	180	PTFE	362264	PM135CT	ZH16	-	16	20.2	018
1"	18	42	2.52	-	0.5	14	-	-30	160	PTFE	364535 ₁	PM156.2DR	ZB09	9	-	20.1	040
	27	193	11.6	-	0.5	10	-	-30	180	PTFE	362265	PM135DT	ZH14	14	-	20.2	019
	27	193	11.6	-	0.5	-	10	-30	180	PTFE	362265	PM135DT	ZH16	-	16	20.2	019

Notes:

1. Maximum pressure for steam: 6.5 Bar (160°C)



For this page	Port size	Orifice (mm)	Kv (l/min)	MOPD (bar)	Fluid Temp (°C)	Amb Temp (°C)
From	3/4"	18	37	10	-30	-10
To	1"	27	193	14	180	50

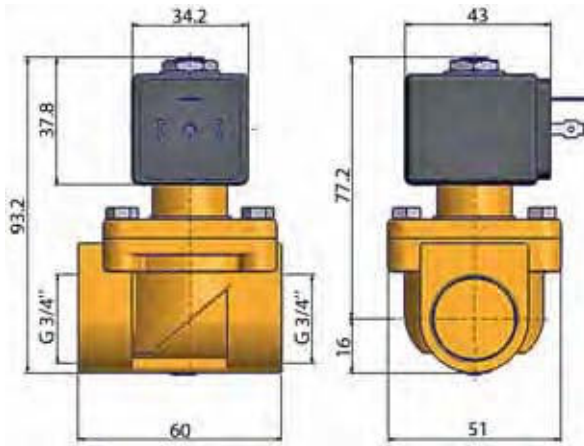

Drawing 039

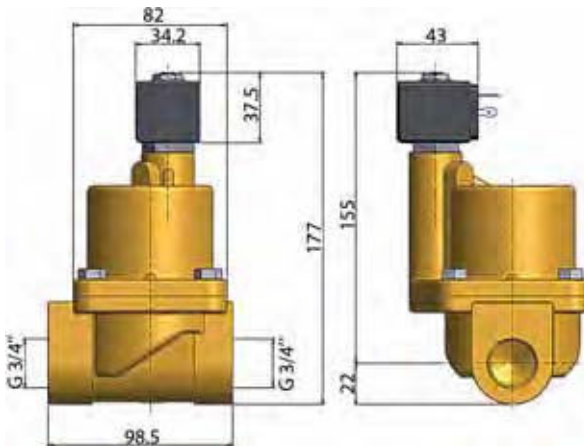

Drawing 018

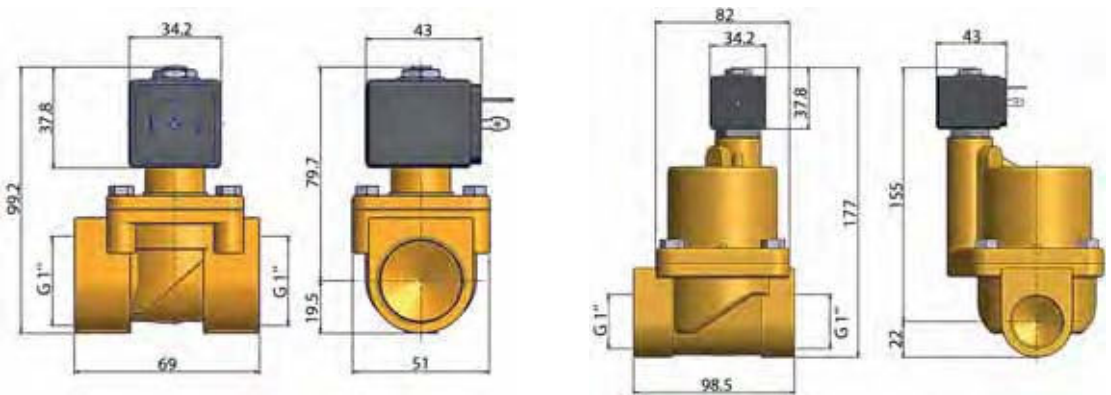

Drawing 040

Drawing 019

2/2

HOT WATER AND STEAM VALVES PILOT OPERATED

BRASS

PIPE MOUNTING

NORMALLY CLOSED

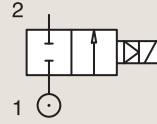

Port size	Orifice Ø	Flow factors			Operating Pressure Differential			Fluid Temp.		Seat Seal	Parker LUCIFER® Valves			Power		Coil Group	Dwg. No.
		Kv l/min	KV m³/h	Qn l/min	Min bar	AC bar	DC bar	Max (MOPD)	Min °C		Max °C	Valve Ref.	Housing Ref.	Coil Ref.	AC W		
BSP	mm																
1/2"	11	36	2.16	-	0.2	10	4	0	120	EPDM	E321K1503	4270	481000	8	8	2.0	3427
	11	36	2.16	-	0.2	10	-	0	100	EPDM	E321K1503	4270	483520	9	-	2.0	3427
	11	36	2.16	-	0.2	10	-	0	120	EPDM	E321K1503	4270	486992	10	-	2.0	3427



For this page	Port size	Orifice (mm)	Kv (l/min)	MOPD (bar)	Fluid Temp (°C)	Amb Temp (°C)
From	1/2"	11	36	4	0	-10
To	1/2"	11	36	10	120	50

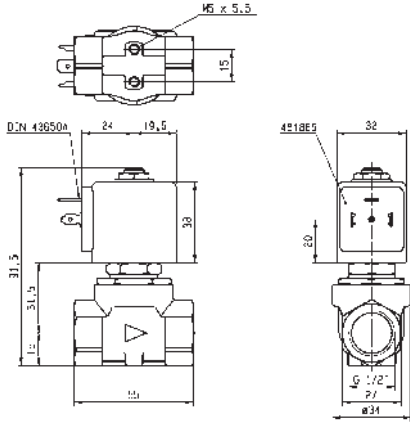

Drawing 3427

2 WAY VALVES





VALVES FOR HYDRAULIC OIL AND NEUTRAL LIQUIDS (UP TO 100 BAR)



2/2

Actuation	Body	Function	Port Size	Orifice (mm)	Flow Factor Kv(l/min)	MOPD (bar)	Max Fluid Temp. (°C)	Page Parker Valves	Page Parker LUCIFER® Valves
Direct Operated	Brass/Pipe mounting	Normally Closed	1/8"	1.5 to 2.5	3.5	70	130	-	142
			1/4"	1.2 to 3	4.5	100	130	-	142
			3/8"	4 to 6	12	10	120	-	144
		Normally Open	1/8"	2.5	3.5	30	140	-	144
			1/4"	1.5 to 2.5	3.5	40	140	-	144
			Brass/Sub-base mounting	Normally Closed	5 mm	1.5 to 3	4.5	100	130
Pilot Operated	Brass/Pipe mounting	Normally Closed	1/4"	8	36	40	140	-	148
			3/8"	11	50	40	140	-	148
			1/2"	15	60	40	140	-	150
		Normally Open	1/4"	8	36	40	140	-	152
			3/8"	11	50	40	140	-	152
			1/2"	15	60	40	140	-	152
	Brass/Sub-base mounting	Normally Closed	14 mm	14	45	40	140	-	154
		Normally Open	14 mm	14	45	40	120	-	154

2/2

VALVES FOR HYDRAULIC OIL AND NEUTRAL LIQUIDS (UP TO 100 BAR) DIRECT OPERATED



Industrial Equipment



Commercial Equipment



Heating Systems

BRASS PIPE MOUNTING

NORMALLY CLOSED

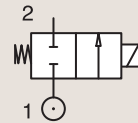

Port size	Orifice Ø	Flow factors			Operating Pressure Differential			Fluid Temp.		Seat Seal	Parker LUCIFER® Valves			Power		Coil Group	Dwg. No.
		Kv l/min	KV m³/h	Qn l/min	Min bar	Max(MOPD) AC bar	DC bar	Min °C	Max °C		Valve Ref.	Housing Ref.	Coil Ref.	AC W	DC W		
1/8"	1.5	1.5	0.09	80	0	60	25	-30	75	PCTFE	E121K14	2995	481865	8	9	2.0	3510
	1.5	1.5	0.09	80	0	70	30	-30	75	PCTFE	E121K14	4270	481000	8	8	2.0	3510
	1.5	1.5	0.09	80	0	70	55	-30	75	PCTFE	E121K14	4270	486265	14	14	2.0	3510
	2.5	3.5	0.21	220	0	28	10	-30	100	Ruby	E121K23	2995	481865	8	9	2.0	3510
	2.5	3.5	0.21	220	0	34	12	-30	130	Ruby	E121K23	4270	481000	8	8	2.0	3510
	2.5	3.5	0.21	220	0	50	22	-30	120	Ruby	E121K23	4270	486265	14	14	2.0	3510
1/4"	1.2	0.85	0.05	50	0	80	36	-30	100	Ruby	E121K65	2995	481865	8	9	2.0	3510
	1.2	0.85	0.05	50	0	100	43	-30	130	Ruby	E121K65	4270	481000	8	8	2.0	3510
	1.2	0.85	0.05	50	0	100	75	-30	120	Ruby	E121K65	4270	486265	14	14	2.0	3510
	1.5	1.5	0.09	80	0	60	25	-30	75	PCTFE	E121K04	2995	481865	8	9	2.0	3510
	1.5	1.5	0.09	80	0	70	30	-30	75	PCTFE	E121K04	4270	481000	8	8	2.0	3510
	1.5	1.5	0.09	80	0	70	55	-30	75	PCTFE	E121K04	4270	486265	14	14	2.0	3510
	1.5	1.5	0.09	80	0	60	25	-30	100	Ruby	E121K67	2995	481865	8	9	2.0	3510
	1.5	1.5	0.09	80	0	75	30	-30	130	Ruby	E121K67	4270	481000	8	8	2.0	3510
	1.5	1.5	0.09	80	0	100	55	-30	120	Ruby	E121K67	4270	486265	14	14	2.0	3510
	2.5	3.5	0.21	220	0	28	10	-30	100	Ruby	E121K63	2995	481865	8	9	2.0	3510
	2.5	3.5	0.21	220	0	34	12	-30	130	Ruby	E121K63	4270	481000	8	8	2.0	3510
	2.5	3.5	0.21	220	0	50	22	-30	120	Ruby	E121K63	4270	486265	14	14	2.0	3510
3	4.5	0.27	320	0	20	7	-30	75	PCTFE	E121K03	2995	481865	8	9	2.0/3.0	3510	
3	4.5	0.27	320	0	25	8.5	-30	75	PCTFE	E121K03	4270	481000	8	8	2.0/3.0	3510	



For this page	Port size	Orifice (mm)	Kv (l/min)	MOPD (bar)	Fluid Temp (°C)	Amb Temp (°C)
From	1/8"	1.2	0.85	7	-30	-10
To	1/4"	3	4.5	100	130	50

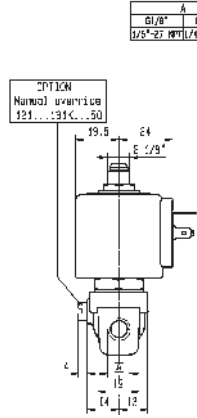
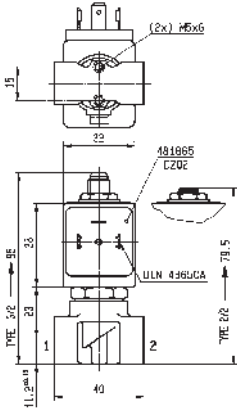

Drawing 3510

2/2

VALVES FOR HYDRAULIC OIL AND NEUTRAL LIQUIDS (UP TO 100 BAR) DIRECT OPERATED

BRASS

PIPE MOUNTING

NORMALLY CLOSED

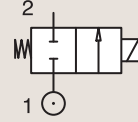

Port size	Orifice Ø	Flow factors			Operating Pressure Differential			Fluid Temp.		Seat Seal	Parker LUCIFER® Valves			Power		Coil Group	Dwg. No.
		BSP	mm	Kv l/min	KV m³/h	Qn l/min	Min bar	Max(MOPD) AC bar	DC bar		Min °C	Max °C	Valve Ref.	Housing Ref.	Coil Ref.		
1/4"	3	4.5	0.27	320	0	36	15	-30	75	PCTFE	E121K03	4270	486265	14	14	2.0/3.0	3510
	3	4.5	0.27	320	0	20	7	-30	100	Ruby	E121K64	2995	481865	8	9	2.0	3510
	3	4.5	0.27	320	0	25	8.5	-30	130	Ruby	E121K64	4270	481000	8	8	2.0	3510
	3	4.5	0.27	320	0	36	15	-30	120	Ruby	E121K64	4270	486265	14	14	2.0	3510
3/8"	4	7.5	0.45	480	0	10	4	-10	100	FKM	121K3206	2995	481865	8	9	2.0	3551
	4	7.5	0.45	480	0	10	5	-10	120	FKM	121K3206	4270	481000	8	8	2.0	3551
	4	7.5	0.45	480	0	10	10	-10	120	FKM	121K3206	4270	486265	14	14	2.0	3551
	5	11	0.66	750	0	7	2	-10	100	FKM	121K3106	2995	481865	8	9	2.0	3551
	5	11	0.66	750	0	7	2.8	-10	120	FKM	121K3106	4270	481000	8	8	2.0	3551
	5	11	0.66	750	0	7	5	-10	120	FKM	121K3106	4270	486265	14	14	2.0	3551
	6	12	0.72	1100	0	5	1.1	-10	100	FKM	121K3306	2995	481865	8	9	2.0/14.2	3551
	6	12	0.72	1100	0	5	1.5	-10	120	FKM	121K3306	4270	481000	8	8	2.0/14.2	3551
6	12	0.72	1100	0	5	3	-10	120	FKM	121K3306	4270	486265	14	14	2.0/14.2	3551	

BRASS

PIPE MOUNTING

NORMALLY OPEN

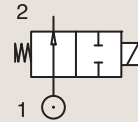

Port size	Orifice Ø	Flow factors			Operating Pressure Differential			Fluid Temp.		Seat Seal	Parker LUCIFER® Valves			Power		Coil Group	Dwg. No.
		BSP	mm	Kv l/min	KV m³/h	Qn l/min	Min bar	Max(MOPD) AC bar	DC bar		Min °C	Max °C	Valve Ref.	Housing Ref.	Coil Ref.		
1/8"	2.5	3.5	0.21	-	0	30	-	-30	140	Ruby	122K9363	4270	481044	14	-	2.2	3510
	2.5	3.5	0.21	-	0	30	30	-30	140	Ruby	122K9363	4270	486265	14	14	2.2	3510
1/4"	1.5	1.5	0.09	9.6	0	30	30	-10	100	PCTFE	122K84	2995	481865	8	9	2.0	3510
	1.5	1.5	0.09	9.6	0	30	30	-10	100	PCTFE	122K84	4270	481000	8	8	2.0	3510
	1.5	1.5	0.09	9.6	0	30	30	-10	120	PCTFE	122K84	4270	486265	14	14	2.0	3510
	1.5	1.5	0.09	80	0	40	40	-30	100	Ruby	122K8408	2995	481865	8	9	2.1	3510
	1.5	1.5	0.09	80	0	40	40	-30	130	Ruby	122K8408	4270	481000	8	8	2.1	3510
	1.5	1.5	0.09	80	0	40	40	-30	130	Ruby	122K8408	4270	486265	14	14	2.0	3510
	2.5	3.5	0.21	-	0	30	-	-30	140	Ruby	122K8363	4270	481044	14	-	2.2	3510
	2.5	3.5	0.21	-	0	30	30	-30	140	Ruby	122K8363	4270	486265	14	14	2.2	3510



For this page	Port size	Orifice (mm)	Kv (l/min)	MOPD (bar)	Fluid Temp (°C)	Amb Temp (°C)
From	1/8"	1.5	1.5	1.1	-30	-10
To	3/8"	6	12	40	140	50

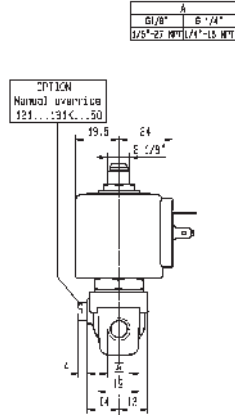
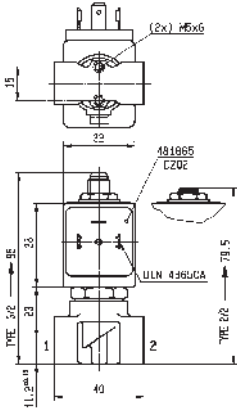

Drawing 3510

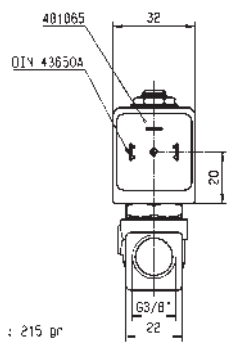
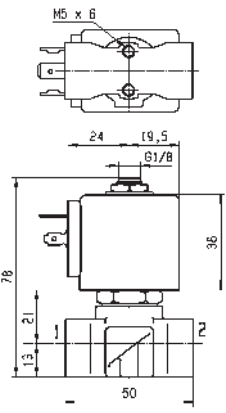

WEIGHT : 215 gr



Drawing 3551

2/2

VALVES FOR HYDRAULIC OIL AND NEUTRAL LIQUIDS (UP TO 100 BAR) DIRECT OPERATED

BRASS

SUB-BASE MOUNTING

NORMALLY CLOSED

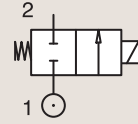

Port size	Orifice Ø mm	Flow factors			Operating Pressure Differential Max(MOPD)			Fluid Temp.		Seat Seal	Parker LUCIFER® Valves			Power		Coil Group	Dwg. No.
		Kv l/min	KV m³/h	Qn l/min	Min bar	AC bar	DC bar	Min °C	Max °C		Valve Ref.	Housing Ref.	Coil Ref.	AC W	DC W		
SB	1.5	1.5	0.09	80	0	60	25	-30	100	Ruby	121F67	2995	481865	8	9	2.0	3509
	1.5	1.5	0.09	80	0	75	30	-30	130	Ruby	121F67	4270	481000	8	8	2.0	3509
	1.5	1.5	0.09	80	0	100	55	-30	120	Ruby	121F67	4270	486265	14	14	2.0	3509
	1.5	1.5	0.09	80	0	60	25	-30	75	PCTFE	E121F44	2995	481865	8	9	2.0	3509
	1.5	1.5	0.09	80	0	70	30	-30	75	PCTFE	E121F44	4270	481000	8	8	2.0	3509
	1.5	1.5	0.09	80	0	70	55	-30	75	PCTFE	E121F44	4270	486265	14	14	2.0	3509
	2.5	3.5	0.21	220	0	14	10	-10	100	FKM	121F4706	2995	481865	8	9	2.0	3509
	2.5	3.5	0.21	220	0	14	9	-10	120	FKM	121F4706	4270	481000	8	8	2.0	3509
	2.5	3.5	0.21	220	0	14	14	-10	120	FKM	121F4706	4270	486265	14	14	2.0	3509
	2.5	3.5	0.21	220	0	28	10	-30	100	Ruby	121F63	2995	481865	8	9	2.0	3509
	2.5	3.5	0.21	220	0	34	12	-30	130	Ruby	121F63	4270	481000	8	8	2.0	3509
	2.5	3.5	0.21	220	0	50	22	-30	120	Ruby	121F63	4270	486265	14	14	2.0	3509
	3	4.5	0.27	320	0	20	7	-30	100	Ruby	121F64	2995	481865	8	9	2.0	3509
	3	4.5	0.27	320	0	25	8.5	-30	130	Ruby	121F64	4270	481000	8	8	2.0	3509
	3	4.5	0.27	320	0	36	15	-30	120	Ruby	121F64	4270	486265	14	14	2.0	3509
	3	4.5	0.27	320	0	20	7	-30	75	PCTFE	E121F43	2995	481865	8	9	2.0	3509
	3	4.5	0.27	320	0	25	8.5	-30	75	PCTFE	E121F43	4270	481000	8	8	2.0	3509
3	4.5	0.27	320	0	36	15	-30	75	PCTFE	E121F43	4270	486265	14	14	2.0	3509	



For this page	Port size	Orifice (mm)	Kv (l/min)	MOPD (bar)	Fluid Temp (°C)	Amb Temp (°C)
From	5 mm	1.5	1.5	7	-30	-10
To	5 mm	3	4.5	100	130	50

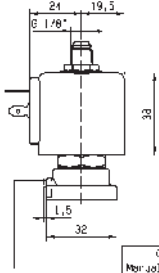
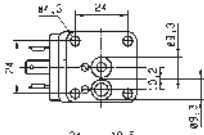

OPTICA
Materiál: 316L
121...131F...50

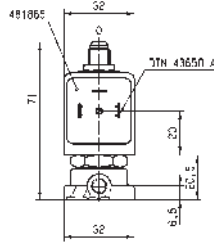

Drawing 3509

2/2

VALVES FOR HYDRAULIC OIL AND NEUTRAL LIQUIDS (UP TO 100 BAR)
PILOT OPERATED

Commercial Equipment



Industrial Equipment



Heating Systems

BRASS
PIPE MOUNTING

NORMALLY CLOSED

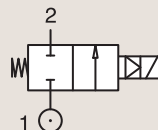

Port size	Orifice Ø	Flow factors			Operating Pressure Differential			Fluid Temp.		Seat Seal	Parker LUCIFER® Valves			Power		Coil Group	Dwg. No.
		Kv l/min	KV m³/h	Qn l/min	Min bar	Max(MOPD) AC bar	DC bar	Min °C	Max °C		Valve Ref.	Housing Ref.	Coil Ref.	AC W	DC W		
1/4"	8	36	2.16	1600	0.3	40	25	-10	100	NBR	E321H11 ¹²	2995	481865	8	9	2.0	3523
	8	36	2.16	1600	0.3	40	30	-10	100	NBR	E321H11 ¹²	4270	481000	8	8	2.0	3523
	8	36	2.16	1600	0.3	40	40	-10	100	NBR	E321H11 ¹²	4270	486265	14	14	2.0	3523
	8	36	2.16	-	0.3	40	25	-10	100	FKM	E321H21 ¹²	2995	481865	8	9	2.0	3523
	8	36	2.16	-	0.3	40	30	-10	120	FKM	E321H21 ¹²	4270	481000	8	8	2.0	3523
	8	36	2.16	-	0.3	40	40	-10	140	FKM	E321H21 ¹²	4270	486265	14	14	2.0	3523
	8	36	2.16	-	0.3	40	40	-10	140	FKM	E321H21 ¹²	4270	486265	14	14	2.0	3523
3/8"	11	50	3	2800	0.3	40	25	-10	100	NBR	E321H13 ¹²	2995	481865	8	9	2.0	3521
	11	50	3	2800	0.3	40	30	-10	100	NBR	E321H13 ¹²	4270	481000	8	8	2.0	3521
	11	50	3	2800	0.3	40	40	-10	100	NBR	E321H13 ¹²	4270	486265	14	14	2.0	3521
	11	50	3	-	0.3	40	25	-10	100	FKM	E321H23 ¹²	2995	481865	8	9	2.0	3521
	11	50	3	-	0.3	40	30	-10	120	FKM	E321H23 ¹²	4270	481000	8	8	2.0	3521
	11	50	3	-	0.3	40	40	-10	140	FKM	E321H23 ¹²	4270	486265	14	14	2.0	3521
	11	36	2.16	-	0.2	20	-	-10	100	Ruby	E321K63	2995	483510	9	-	2.0	3429
	11	36	2.16	-	0.2	30	-	-10	140	Ruby	E321K63	4270	488553	9	-	2.0	3429
11	36	2.16	-	0.2	4	4	-10	120	Ruby	E321K63	-	492190	11	9	2.0	3429	

Notes:

1. Minimum pressure differential = 0.3 bar for opening and 0 bar for closing
2. Pilot seat disc in synthetic Ruby



For this page	Port size	Orifice (mm)	Kv (l/min)	MOPD (bar)	Fluid Temp (°C)	Amb Temp (°C)
From	1/4"	8	36	3	-10	-10
To	3/8"	11	50	40	140	50

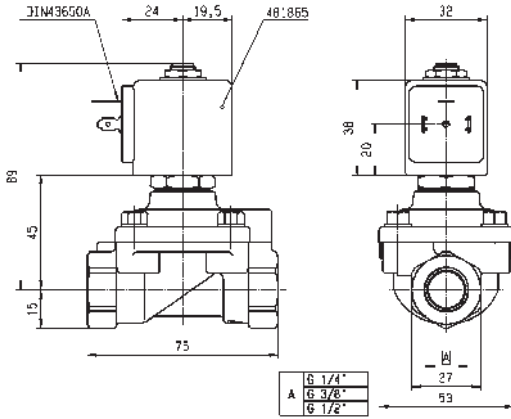

Drawing 3523

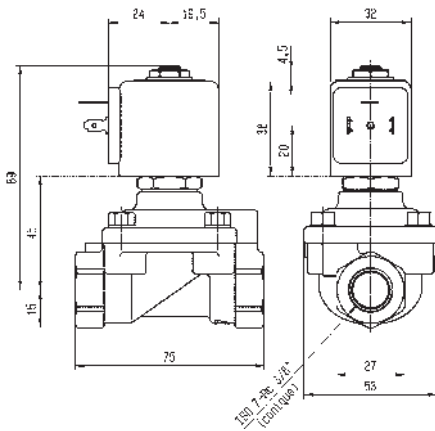

Drawing 3521

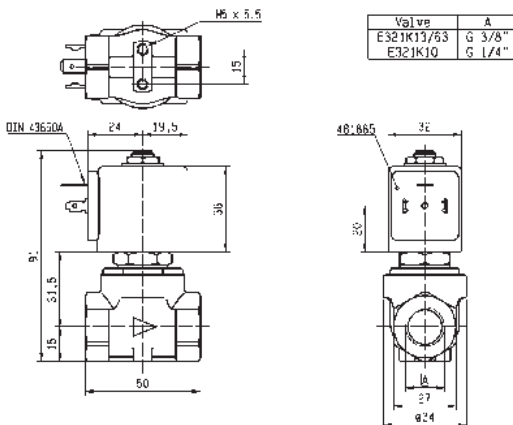

Drawing 3429

2/2

VALVES FOR HYDRAULIC OIL AND NEUTRAL LIQUIDS (UP TO 100 BAR) PILOT OPERATED

BRASS

PIPE MOUNTING

NORMALLY CLOSED

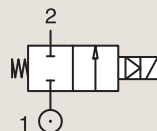

Port size	Orifice Ø	Flow factors			Operating Pressure Differential			Fluid Temp.		Seat Seal	Parker LUCIFER® Valves			Power		Coil Group	Dwg. No.
		Kv l/min	KV m³/h	Qn l/min	Min bar	Max(MOPD) AC bar	DC bar	Min °C	Max °C		Valve Ref.	Housing Ref.	Coil Ref.	AC W	DC W		
1/2"	15	60	3.6	3150	0.3	40	25	-10	100	NBR	E321H15 ¹²	2995	481865	8	9	2.0	3522
	15	60	3.6	3150	0.3	40	30	-10	100	NBR	E321H15 ¹²	4270	481000	8	8	2.0	3522
	15	60	3.6	3150	0.3	40	40	-10	100	NBR	E321H15 ¹²	4270	486265	14	14	2.0	3522
	15	60	3.6	-	0.3	40	25	-10	100	FKM	E321H25 ¹²	2995	481865	8	9	2.0/14.2	3522
	15	60	3.6	-	0.3	40	30	-10	120	FKM	E321H25 ¹²	-	483371	8	8	2.0/14.2	3522
	15	60	3.6	-	0.3	40	40	-10	140	FKM	E321H25 ¹²	4270	486265	14	14	2.0/14.2	3522

Notes:

1. Minimum pressure differential = 0.3 bar for opening and 0 bar for closing
2. Pilot seat disc in synthetic Ruby



For this page	Port size	Orifice (mm)	Kv (l/min)	MOPD (bar)	Fluid Temp (°C)	Amb Temp (°C)
From	1/2"	15	60	25	-10	-10
To	1/2"	15	60	40	140	50

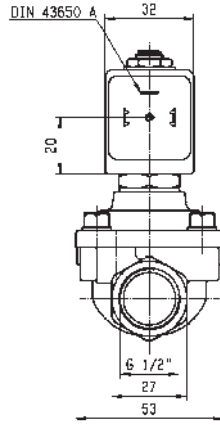
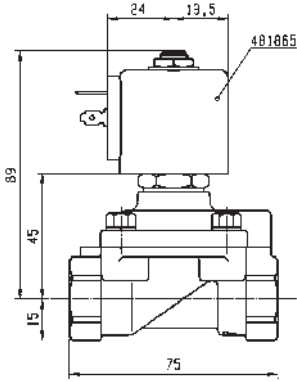

Drawing 3522

2/2

VALVES FOR HYDRAULIC OIL AND NEUTRAL LIQUIDS (UP TO 100 BAR) PILOT OPERATED

BRASS

PIPE MOUNTING

NORMALLY OPEN

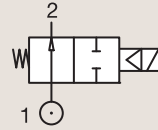

Port size	Orifice Ø	Flow factors			Operating Pressure Differential			Fluid Temp.		Seat Seal	Parker LUCIFER® Valves			Power		Coil Group	Dwg. No.
		Kv l/min	KV m³/h	Qn l/min	Min bar	Max(MOPD) AC bar	DC bar	Min °C	Max °C		Valve Ref.	Housing Ref.	Coil Ref.	AC W	DC W		
1/4"	8	36	2.16	-	0.3	40	40	-10	100	FKM	322H7106 ¹²	2995	481865	8	9	2.0/14.1	3523
	8	36	2.16	-	0.3	40	40	-10	120	FKM	322H7106 ¹²	4270	481000	8	8	2.0/14.1	3523
	8	36	2.16	-	0.3	40	40	-10	140	FKM	322H7106 ¹²	4270	486265	14	14	2.0/14.1	3523
3/8"	11	50	3	3240	0.3	40	40	-10	75	NBR	322H73 ¹²	2995	481865	8	9	2.0	3523
	11	50	3	3240	0.3	40	40	-10	75	NBR	322H73 ¹²	4270	481000	8	8	2.0	3523
	11	50	3	3240	0.3	40	40	-10	75	NBR	322H73 ¹²	4270	486265	14	14	2.0	3523
	11	50	3	-	0.3	40	40	-10	100	FKM	322H7306 ¹²	2995	481865	8	9	2.0/14.1	3523
	11	50	3	-	0.3	40	40	-10	100	FKM	322H7306 ¹²	4270	481000	8	8	2.0/14.1	3523
	11	50	3	-	0.3	40	40	-10	140	FKM	322H7306 ¹²	4270	486265	14	14	2.0/14.1	3523
1/2"	15	60	3.6	3890	0.3	20	20	-10	100	FKM	322G7506 ¹	2995	481865	8	9	2.0	3522
	15	60	3.6	3890	0.3	20	20	-10	100	FKM	322G7506 ¹	4270	481000	8	8	2.0	3522
	15	60	3.6	3890	0.3	20	20	-10	100	FKM	322G7506 ¹	4270	486265	14	14	2.0	3522
	15	60	3.6	3890	0.3	40	40	-10	100	NBR	322H75 ¹²	2995	481865	8	9	2.0	3522
	15	60	3.6	3890	0.3	40	40	-10	100	NBR	322H75 ¹²	4270	481000	8	8	2.0	3522
	15	60	3.6	3890	0.3	40	40	-10	100	NBR	322H75 ¹²	4270	486265	14	14	2.0	3522
	15	60	3.6	-	0.3	40	40	-10	100	FKM	322H7506 ¹²	2995	481865	8	9	2.0/14.1	3522
	15	60	3.6	-	0.3	40	40	-10	120	FKM	322H7506 ¹²	4270	481000	8	8	2.0/14.1	3522
15	60	3.6	-	0.3	40	40	-10	140	FKM	322H7506 ¹²	4270	486265	14	14	2.0/14.1	3522	

Notes:

- 1. Minimum pressure differential = 0.3 bar for opening and 0 bar for closing
- 2. Pilot seat disc in synthetic Ruby



For this page	Port size	Orifice (mm)	Kv (l/min)	MOPD (bar)	Fluid Temp (°C)	Amb Temp (°C)
From	1/4"	8	36	20	-10	-10
To	1/2"	15	60	40	140	50

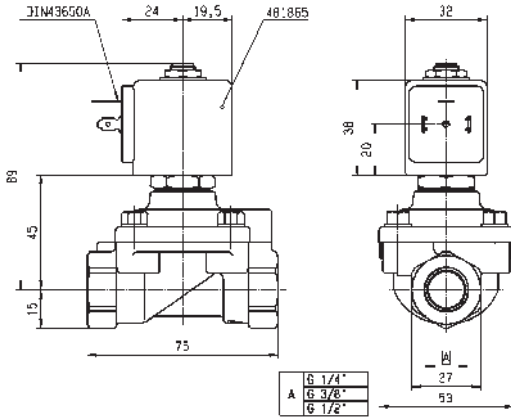

Drawing 3523

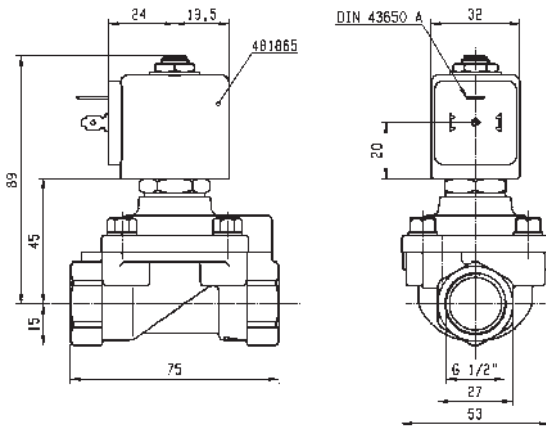

Drawing 3522

2/2

VALVES FOR HYDRAULIC OIL AND NEUTRAL LIQUIDS (UP TO 100 BAR)
PILOT OPERATED

BRASS

SUB-BASE MOUNTING

NORMALLY CLOSED

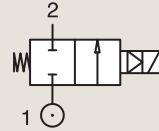

Port size	Orifice Ø	Flow factors			Operating Pressure Differential			Fluid Temp.		Seat Seal	Parker LUCIFER® Valves			Power		Coil Group	Dwg. No.
		Kv l/min	KV m³/h	Qn l/min	Min bar	Max(MOPD) AC bar	DC bar	Min °C	Max °C		Valve Ref.	Housing Ref.	Coil Ref.	AC W	DC W		
BSP	mm																
	14	45	2.7	-	0.3	40	25	-10	100	FKM	E321F3202 ¹²	2995	481865	8	9	2.0	3520
SB	14	45	2.7	-	0.3	40	30	-10	120	FKM	E321F3202 ¹²	4270	481000	8	8	2.0	3520
	14	45	2.7	-	0.3	40	40	-10	140	FKM	E321F3202 ¹²	4270	486265	14	14	2.0	3520

Notes:

1. Minimum pressure differential = 0.3 bar for opening and 0 bar for closing
2. Pilot seat disc in synthetic Ruby

BRASS

SUB-BASE MOUNTING

NORMALLY OPEN

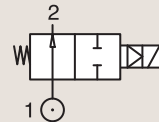

Port size	Orifice Ø	Flow factors			Operating Pressure Differential			Fluid Temp.		Seat Seal	Parker LUCIFER® Valves			Power		Coil Group	Dwg. No.
		Kv l/min	KV m³/h	Qn l/min	Min bar	Max(MOPD) AC bar	DC bar	Min °C	Max °C		Valve Ref.	Housing Ref.	Coil Ref.	AC W	DC W		
BSP	mm																
	14	45	2.7	-	0.3	40	40	0	100	FKM	322F7206 ¹²	2995	481865	8	9	2.1/14.1	3520
SB	14	45	2.7	-	0.3	40	40	0	120	FKM	322F7206 ¹²	4270	481000	8	8	2.1/14.1	3520

Notes:

1. Minimum pressure differential = 0.3 bar for opening and 0 bar for closing
2. Pilot seat disc in synthetic Ruby



For this page	Port size	Orifice (mm)	Kv (l/min)	MOPD (bar)	Fluid Temp (°C)	Amb Temp (°C)
From	14 mm	14	45	25	-10	-10
To	14 mm	14	45	40	140	50

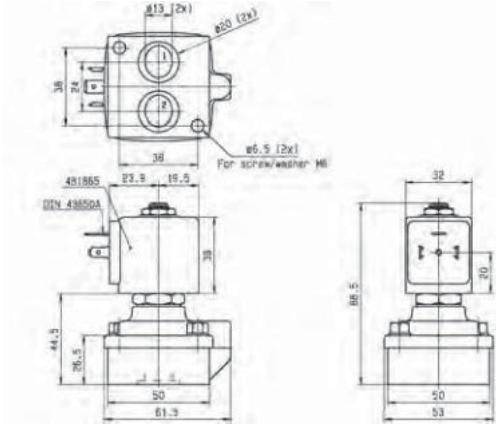

Drawing 3520

2 WAY VALVES

HIGH CORROSION RESISTANT VALVES (303 STAINLESS STEEL)



2/2

Actuation	Body	Function	Port Size	Orifice (mm)	Flow Factor Kv(l/min)	MOPD (bar)	Max Fluid Temp. (°C)	Page Parker Valves	Page Parker LUCIFER® Valves
Direct Operated	303 Stainless St./Pipe mounting	Normally Closed	1/4"	1.5 to 5	10	100	180	-	158
		Normally Open	1/4"	2.5	3	12	120	-	162

2/2

HIGH CORROSION RESISTANT VALVES (303 STAINLESS STEEL) DIRECT OPERATED



Process



Commercial Equipment

303 STAINLESS ST. PIPE MOUNTING

NORMALLY CLOSED

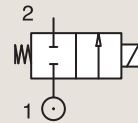

Port size	Orifice Ø	Flow factors			Operating Pressure Differential			Fluid Temp.		Seat Seal	Parker LUCIFER® Valves			IS	Power		Coil Group	Dwg. No.
		Kv l/min	KV m³/h	Qn l/min	Min bar	Max(MOPD) AC bar	DC bar	Min °C	Max °C		Valve Ref.	Housing Ref.	Coil Ref.		AC W	DC W		
1/4"	1.5	1.5	0.09	80	0	20	20	-10	100	FKM	121V5406	2995	481865	8	9	2.0	8116	
	1.5	1.5	0.09	80	0	20	20	-10	120	FKM	121V5406	4270	481000	8	8	2.0	8116	
	1.5	1.5	0.09	80	0	60	25	0	100	Ruby	121V5463 ₁	2995	481865	8	9	2.0	8116	
	1.5	1.5	0.09	80	0	75	30	0	130	Ruby	121V5463 ₁	4270	481000	8	8	2.0	8116	
	1.5	1.5	0.09	80	0	100	55	0	140	Ruby	121V5463 ₁	4270	486265	14	14	2.0	8116	
	1.5	1.5	0.09	80	0	-	8	-20	75	PUR	121V5497 ₂	2995	482740	-	1.6	3.0/6.0/8.0	8024	
	1.5	1.5	0.09	80	0	10	10	-20	75	PUR	121V5497 ₂	-	495900	2.5	2	3.0/6.0/8.0	8024	
	1.5	1.5	0.09	80	0	-	10	-20	75	PUR	121V5497 ₂	-	495910	*	-	0.3 to 3	3.0/6.0/8.0	8024
	1.5	1.5	0.09	80	0	-	8	-20	75	PUR	121V5497 ₂	2995	496125	-	1.6	3.0/6.0/8.0	8024	
	2.5	3.5	0.21	220	0	14	7	-10	100	FKM	121V5706	2995	481865	8	9	2.0	8116	
	2.5	3.5	0.21	220	0	14	9	-10	120	FKM	121V5706	4270	481000	8	8	2.0	8116	
	2.5	3.5	0.21	220	0	14	14	-10	120	FKM	121V5706	4270	486265	14	14	2.0	8116	
	2.5	3.5	0.21	220	0	28	10	0	100	Ruby	121V5763 ₁	2995	481865	8	9	2.0	8116	
	2.5	3.5	0.21	220	0	34	12	0	130	Ruby	121V5763 ₁	4270	481000	8	8	2.0	8116	
	2.5	3.5	0.21	220	0	50	22	0	140	Ruby	121V5763 ₁	4270	486265	14	14	2.0	8116	
	3	4.5	0.27	315	0	10	7	-10	100	FKM	121V5306	2995	481865	8	9	2.0	8116	
	3	4.5	0.27	315	0	10	8.5	-10	120	FKM	121V5306	4270	481000	8	8	2.0	8116	
	3	4.5	0.27	315	0	10	10	-10	120	FKM	121V5306	4270	486265	14	14	2.0	8116	
	3	4.5	0.27	315	0	20	7	0	100	Ruby	121V5363 ₁	2995	481865	8	9	2.0	8116	
	3	4.5	0.27	315	0	25	8.5	0	130	Ruby	121V5363 ₁	4270	481000	8	8	2.0	8116	
3	4.5	0.27	315	0	36	15	0	140	Ruby	121V5363 ₁	4270	486265	14	14	2.0	8116		

Notes:

- 1. Valve only compatible with hydraulic oil and neutral liquids
- 2. Valve compatible with water only up to 40°C

2 WAY VALVES



For this page	Port size	Orifice (mm)	Kv (l/min)	MOPD (bar)	Fluid Temp (°C)	Amb Temp (°C)
From	1/4"	1.5	1.5	7	-20	-20
To	1/4"	3	4.5	100	140	50

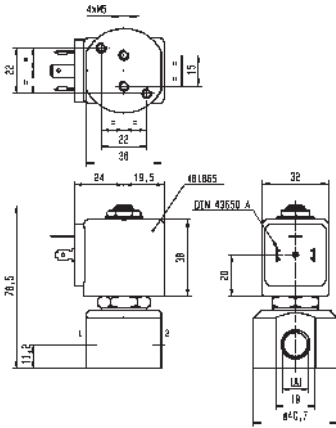

A	G 1/8"
	G 1/4"



Drawing 8116

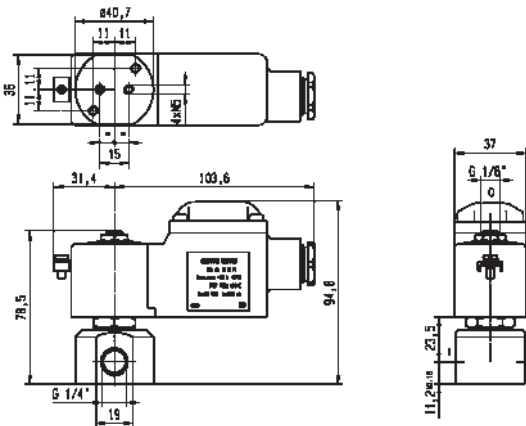

Drawing 8024

2/2

HIGH CORROSION RESISTANT VALVES (303 STAINLESS STEEL) DIRECT OPERATED

303 STAINLESS ST.
PIPE MOUNTING

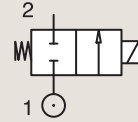

NORMALLY CLOSED

Port size	Orifice Ø	Flow factors			Operating Pressure Differential			Fluid Temp.		Seat Seal	Parker LUCIFER® Valves			IS	Power		Coil Group	Dwg. No.
		Kv l/min	KV m³/h	Qn l/min	Min bar	AC bar	DC bar	Min °C	Max °C		Valve Ref.	Housing Ref.	Coil Ref.		AC W	DC W		
1/4"	3	3.5	0.21	220	0	-	2	-20	75	PUR	121V5397 ₂	2995	482740	-	1.6	3.0/6.0/8.0	8024	
	3	3.5	0.21	220	0	4.5	4	-20	75	PUR	121V5397 ₂	-	495900	2.5	2	3.0/6.0/8.0	8024	
	3	3.5	0.21	220	0	-	4.5	-20	75	PUR	121V5397 ₂	-	495910	*	0.3 to 3	3.0/6.0/8.0	8024	
	3	3.5	0.21	220	0	-	2	-20	75	PUR	121V5397 ₂	2995	496125	-	1.6	3.0/6.0/8.0	8024	
	4	7	0.42	450	0	10	4	-10	100	FKM	121V5206	2995	481865	8	9	2.0	8116	
	4	7	0.42	450	0	10	5	-10	120	FKM	121V5206	4270	481000	8	8	2.0	8116	
	4	7	0.42	450	0	10	10	-10	120	FKM	121V5206	4270	486265	14	14	2.0	8116	
	4	7	0.42	450	0	3.5	3.5	0	100	PTFE	121V5212 ₁	2995	481865	8	9	2.0	8116	
	4	7	0.42	450	0	3.5	3.5	0	130	PTFE	121V5212 ₁	4270	481000	8	8	2.0	8116	
	4	7	0.42	450	0	3.5	3.5	0	130	PTFE	121V5212 ₁	4270	486265	14	14	2.0	8116	
	4	7	0.42	450	0	12	4	0	100	Ruby	121V5263 ₁	2995	481865	8	9	2.0	8116	
	4	7	0.42	450	0	15	5	0	130	Ruby	121V5263 ₁	4270	481000	8	8	2.0	8116	
	4	7	0.42	450	0	22	10	0	180	Ruby	121V5263 ₁	4270	486265	14	14	2.0	8116	
	5	10	0.6	750	0	7	2	-10	100	FKM	121V5106	2995	481865	8	9	2.0	8116	
	5	10	0.6	750	0	7	2.8	-10	120	FKM	121V5106	4270	481000	8	8	2.0	8116	
	5	10	0.6	750	0	7	5	-10	120	FKM	121V5106	4270	486265	14	14	2.0	8116	
	5	10	0.6	-	0	2.8	2	0	100	PTFE	121V5112 ₁	2995	481865	8	9	2.0	8116	
	5	10	0.6	-	0	2.8	2.8	0	130	PTFE	121V5112 ₁	4270	481000	8	8	2.0	8116	
	5	10	0.6	-	0	2.8	2.8	0	130	PTFE	121V5112 ₁	4270	486265	14	14	2.0	8116	
	5	10	0.6	750	0	8.5	2	0	100	Ruby	121V5163 ₁	2995	481865	8	9	2.0	8116	
5	10	0.6	750	0	10	3.5	0	130	Ruby	121V5163 ₁	4270	481000	8	8	2.0	8116		
5	10	0.6	750	0	14	6.5	0	140	Ruby	121V5163 ₁	4270	486265	14	14	2.0	8116		

Notes:

1. Valve only compatible with hydraulic oil and neutral liquids
2. Valve compatible with water only up to 40°C



For this page	Port size	Orifice (mm)	Kv (l/min)	MOPD (bar)	Fluid Temp (°C)	Amb Temp (°C)
From	1/4"	3	3.5	2	-20	-20
To	1/4"	5	10	22	180	50

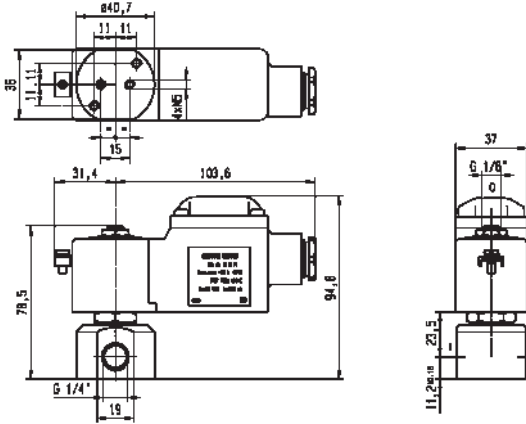

Drawing 8024

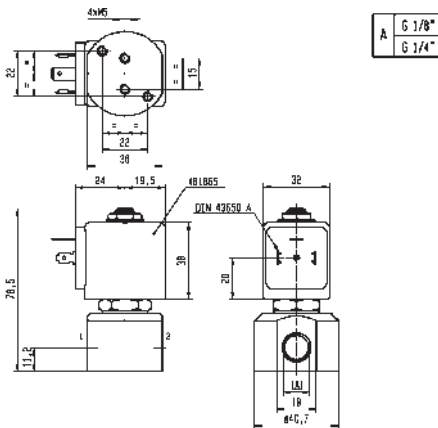

Drawing 8116

2/2

HIGH CORROSION RESISTANT VALVES (303 STAINLESS STEEL) DIRECT OPERATED

303 STAINLESS ST.
PIPE MOUNTING

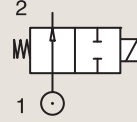

NORMALLY OPEN

Port size	Orifice Ø	Flow factors			Operating Pressure Differential			Fluid Temp.		Seat Seal	Parker LUCIFER® Valves			Power		Coil Group	Dwg. No.
		Kv l/min	KV m³/h	Qn l/min	Min bar	AC bar	DC bar	Min °C	Max °C		Valve Ref.	Housing Ref.	Coil Ref.	AC W	DC W		
1/4"	2.5	3	0.18	180	0	12	12	-30	100	FKM	122V8306	2995	481865	8	9	2.1	8116
	2.5	3	0.18	180	0	12	12	-30	120	FKM	122V8306	4270	481000	8	8	2.1	8116



For this page	Port size	Orifice (mm)	Kv (l/min)	MOPD (bar)	Fluid Temp (°C)	Amb Temp (°C)
From	1/4"	2.5	3	12	-30	-10
To	1/4"	2.5	3	12	120	50

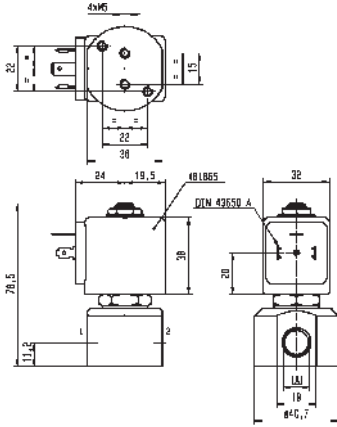

A	G 1/8"
	G 1/4"



Drawing 8116

2 WAY VALVES



HIGH CORROSION RESISTANT VALVES (316L STAINLESS STEEL)



2/2

Actuation	Body	Function	Port Size	Orifice (mm)	Flow Factor Kv(l/min)	MOPD (bar)	Max Fluid Temp. (°C)	Page Parker Valves	Page Parker LUCIFER® Valves
Direct Operated	316L Stainless St./Pipe Mounting	Normally Closed	1/4"	1.5 to 3.5	2.3	20	140	166	-
			1/8"	1.5 to 2.5	2.3	20	140	166	-
			1/2"	5 to 6.2	13	4	140	168	-
			3/8"	5 to 6.2	13	4	140	168	-
			1/4"	1	0.6	98	75	-	170
Magnalift	316L Stainless St./Pipe Mounting	Normally Closed	1/2"	15	50	10	140	172	-
			3/4"	24	95	10	140	172	-
			3/8"	15	40	10	140	172	-
			1"	24	105	10	140	174	-

2/2

HIGH CORROSION RESISTANT VALVES (316L STAINLESS STEEL) DIRECT OPERATED



Commercial Equipment



Medical / Instrumentation



Industrial Equipment

316L STAINLESS ST. PIPE MOUNTING

NORMALLY CLOSED

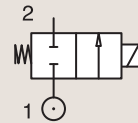

Port size	Orifice Ø	Flow factors			Operating Pressure Differential			Fluid Temp.		Seat Seal	Parker Valves			Power		Coil Group	Dwg. No.
		BSP	mm	Kv l/min	KV m ³ /h	Qn l/min	Min bar	Max(MOPD) AC bar	DC bar		Min °C	Max °C	Valve Ref.	Housing Ref.	Coil Ref.		
1/8"	1.5	1	0.06	-	0	20	-	-10	140	FKM	201LG1GVG2	-	WB4.5	4.5	-	1.1/1.3	074
	1.5	1	0.06	-	0	-	10	-10	140	FKM	201LG1GVG2	-	WB5.0	-	5	1.1/1.3	074
	2	1.8	0.11	-	0	15	-	-10	140	FKM	201LG1JVG2	-	WB4.5	4.5	-	1.1/1.3	074
	2	1.8	0.11	-	0	-	7	-10	140	FKM	201LG1JVG2	-	WB5.0	-	5	1.1/1.3	074
	2.5	2.3	0.14	-	0	10	-	-10	140	FKM	201LG1LVG2	-	WB4.5	4.5	-	1.1/1.3	074
	2.5	2.3	0.14	-	0	-	4	-10	140	FKM	201LG1LVG2	-	WB5.0	-	5	1.1/1.3	074
1/4"	1.5	1	0.06	-	0	20	-	-10	140	FKM	201LG2GVG2	-	WB4.5	4.5	-	1.1/1.3	075
	1.5	1	0.06	-	0	-	10	-10	140	FKM	201LG2GVG2	-	WB5.0	-	5	1.1/1.3	075
	2	1.8	0.11	-	0	15	-	-10	140	FKM	201LG2JVG2	-	WB4.5	4.5	-	1.1/1.3	075
	2	1.8	0.11	-	0	-	7	-10	140	FKM	201LG2JVG2	-	WB5.0	-	5	1.1/1.3	075
	2.5	2.3	0.14	-	0	10	-	-10	140	FKM	201LG2LVG2	-	WB4.5	4.5	-	1.1/1.3	075
	2.5	2.3	0.14	-	0	-	4	-10	140	FKM	201LG2LVG2	-	WB5.0	-	5	1.1/1.3	075
	3	0.5	0.03	-	0	8	8	-10	140	FKM	201LG2NVG7	-	481865	8	9	2.0	076
	3	0.5	0.03	-	0	10	11	-10	140	FKM	201LG2NVG7	-	491514	13	16	2.0	076
	3.5	0.6	0.04	-	0	6	6	-10	140	FKM	201LG2PVG7	-	481865	8	9	2.0	076
3.5	0.6	0.04	-	0	7	8	-10	140	FKM	201LG2PVG7	-	491514	13	16	2.0	076	



For this page	Port size	Orifice (mm)	Kv (l/min)	MOPD (bar)	Fluid Temp (°C)	Amb Temp (°C)
From	1/8"	1.5	0.5	4	-10	-10
To	1/4"	3.5	2.3	20	140	50



Drawing 074

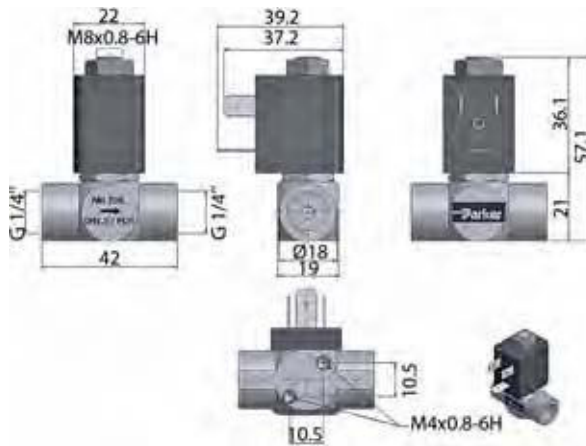

Drawing 075

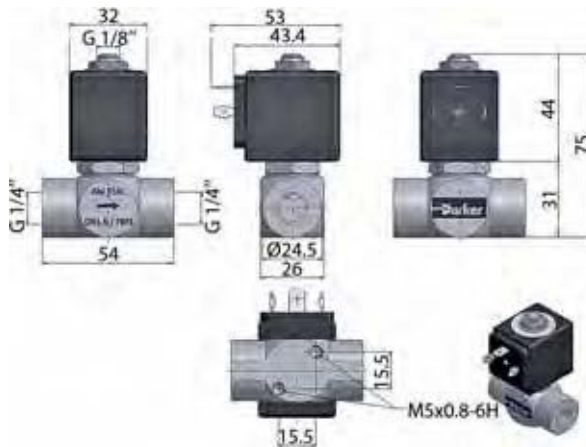

Drawing 076

2/2

HIGH CORROSION RESISTANT VALVES
(316L STAINLESS STEEL)
DIRECT OPERATED

316L STAINLESS ST.
PIPE MOUNTING

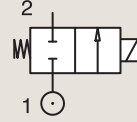

NORMALLY CLOSED

Port size	Orifice Ø	Flow factors			Operating Pressure Differential			Fluid Temp.		Seat Seal	Parker Valves			Power		Coil Group	Dwg. No.
		Kv l/min	KV m ³ /h	Qn l/min	Min bar	Max(MOPD) AC bar	DC bar	Min °C	Max °C		Valve Ref.	Housing Ref.	Coil Ref.	AC W	DC W		
3/8"	5	11	0.66	-	0	3	3	-10	140	FKM	201LG3SVG7	-	481865	8	9	2.0	077
	5	11	0.66	-	0	4	4	-10	140	FKM	201LG3SVG7	-	491514	13	16	2.0	077
	6.2	13	0.78	-	0	2	2	-10	140	FKM	201LG3UVG7	-	481865	8	9	2.0	077
	6.2	13	0.78	-	0	2	3	-10	140	FKM	201LG3UVG7	-	491514	13	16	2.0	077
1/2"	5	11	0.66	-	0	3	3	-10	140	FKM	201LG4SVG7	-	481865	8	9	2.0	078
	5	11	0.66	-	0	4	4	-10	140	FKM	201LG4SVG7	-	491514	13	16	2.0	078
	6.2	13	0.78	-	0	2	2	-10	140	FKM	201LG4UVG7	-	481865	8	9	2.0	078
	6.2	13	0.78	-	0	2	3	-10	140	FKM	201LG4UVG7	-	491514	13	16	2.0	078



For this page	Port size	Orifice (mm)	Kv (l/min)	MOPD (bar)	Fluid Temp (°C)	Amb Temp (°C)
From	3/8"	5	11	2	-10	-10
To	1/2"	6.2	13	4	140	50

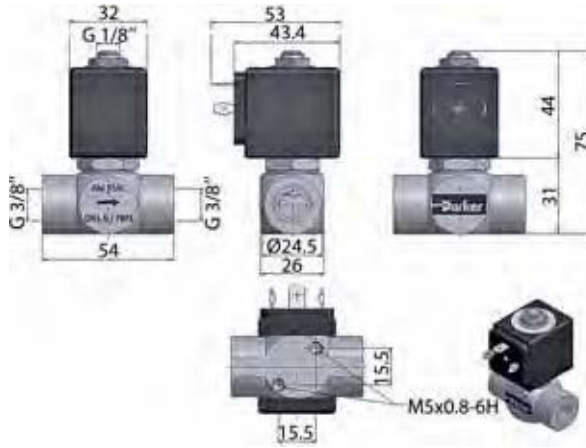

Drawing 077



Drawing 078

2/2

HIGH CORROSION RESISTANT VALVES (316L STAINLESS STEEL) DIRECT OPERATED

316L STAINLESS ST.
PIPE MOUNTING

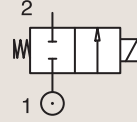

NORMALLY CLOSED

Port size	Orifice Ø mm	Flow factors			Operating Pressure Differential Max(MOPD)			Fluid Temp.		Seat Seal	Parker LUCIFER® Valves			IS	Power		Coil Group	Dwg. No.
		Kv l/min	KV m³/h	Qn l/min	Min bar	AC bar	DC bar	Min °C	Max °C		Valve Ref.	Housing Ref.	Coil Ref.		AC W	DC W		
1/4" NPT	1	0.6	0.036	40	0	-	98	-40	75	PUR	U121V5595 ₁	-	492210	-	1.8	9.0/10.1	6713	
	1	0.6	0.036	40	0	-	98	-40	75	PUR	U121V5595 ₁	-	496565	*	0.3	9.0/10.1	6713	
	1	0.6	0.036	40	0	98	98	-40	75	PUR	U121V5595 ₁	-	496800	8	8	9.0/10.1	6713	
	1	0.6	0.036	40	0	98	98	-40	75	PUR	U121V5595 ₁	-	496895	8	8	9.0/10.1	6713	
	1	0.6	0.036	40	0	98	98	-40	75	PUR	U121V5596 ₁	-	492310	6	6	10.1	6713	
	1	0.6	0.036	40	0	98	98	-40	75	PUR	U121V5596 ₁	-	496560	8	8	10.1	6713	
	1	0.6	0.036	40	0	98	98	-40	75	PUR	U121V5596 ₁	-	496800	8	8	10.1	6713	
	1	-	-	40	0	98	98	-10	75	PUR	U121V55961D ₁	-	483270	8	8	11.0	6714	
1	-	-	40	0	98	98	-10	75	PUR	U121V55961D ₁	-	483270.02	8	8	11.0	6714		

Notes:

1. Valve delivered with an individual material traceability certificate (3.1 following EN10204)



For this page	Port size	Orifice (mm)	Kv (l/min)	MOPD (bar)	Fluid Temp (°C)	Amb Temp (°C)
From	1/4"	1	-	98	-40	-40
To	1/4"	1	0.6	98	75	50

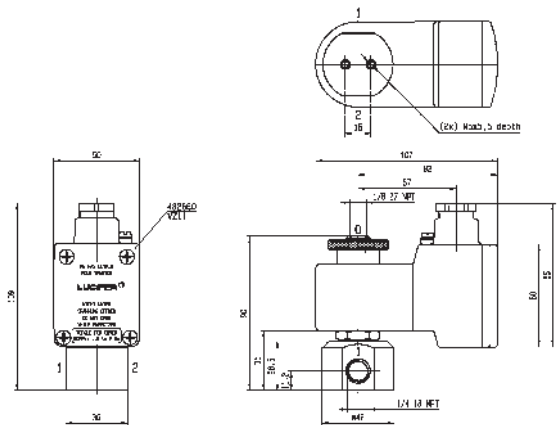

Drawing 6713

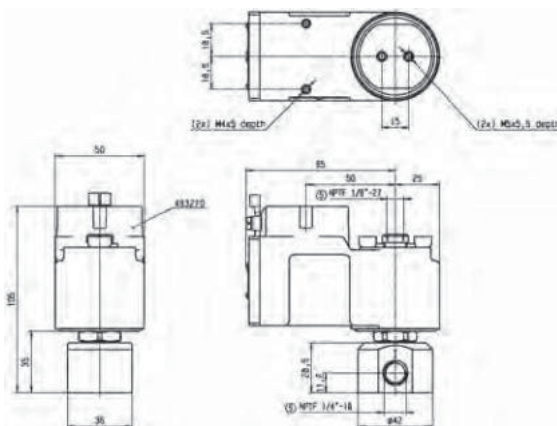

Drawing 6714

2/2

HIGH CORROSION RESISTANT VALVES (316L STAINLESS STEEL) MAGNALIFT



Commercial Equipment



Medical / Instrumentation



Industrial Equipment

316L STAINLESS ST. PIPE MOUNTING

NORMALLY CLOSED

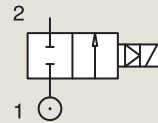

Port size	Orifice Ø	Flow factors			Operating Pressure Differential			Fluid Temp.		Seat Seal	Parker Valves			Power		Coil Group	Dwg. No.
		Kv l/min	KV m³/h	Qn l/min	Min bar	Max(MOPD) AC bar	DC bar	Min °C	Max °C		Valve Ref.	Housing Ref.	Coil Ref.	AC W	DC W		
3/8"	15	40	2.4	-	0	10	-	-10	85	EPDM	221S10E	2995	481865	8	-	2.0	067
	15	40	2.4	-	0	10	7	-10	140	EPDM	221S10E ₁	4270	486265	14	14	2.0	067
	15	40	2.4	-	0	10	-	-10	85	FKM	221S10F	2995	481865	8	-	2.0	067
	15	40	2.4	-	0	10	7	-10	85	FKM	221S10F ₁	4270	486265	14	14	2.0	067
1/2"	15	50	3	-	0	10	-	-10	85	EPDM	221S15E	2995	481865	8	-	2.0	068
	15	50	3	-	0	10	7	-10	140	EPDM	221S15E ₁	4270	486265	14	14	2.0	068
	15	50	3	-	0	10	-	-10	85	FKM	221S15F	2995	481865	8	-	2.0	068
	15	50	3	-	0	10	7	-10	85	FKM	221S15F ₁	4270	486265	14	14	2.0	068
3/4"	24	95	5.7	-	0	10	-	-10	85	EPDM	221S20E	2995	481865	8	-	2.0	069
	24	95	5.7	-	0	10	7	-10	140	EPDM	221S20E ₁	4270	486265	14	14	2.0	069
	24	95	5.7	-	0	10	-	-10	85	FKM	221S20F	2995	481865	8	-	2.0	069
	24	95	5.7	-	0	10	7	-10	85	FKM	221S20F ₁	4270	486265	14	14	2.0	069

Notes:

1. Maximum pressure for steam: 4 Bar (140°C)



For this page	Port size	Orifice (mm)	Kv (l/min)	MOPD (bar)	Fluid Temp (°C)	Amb Temp (°C)
From	3/8"	15	40	7	-10	-10
To	3/4"	24	95	10	140	50

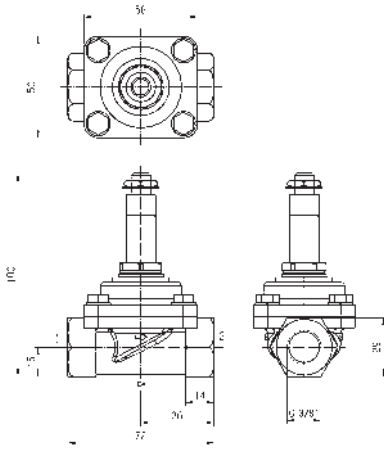

Drawing 067

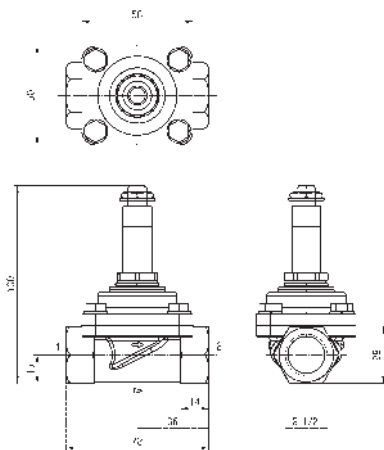

Drawing 068

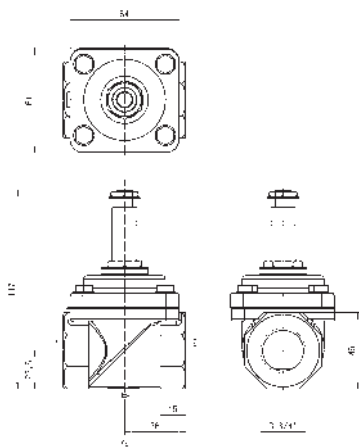

Drawing 069

2/2

HIGH CORROSION RESISTANT VALVES (316L STAINLESS STEEL) MAGNALIFT

316L STAINLESS ST.
PIPE MOUNTING

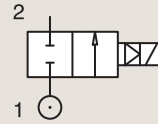

NORMALLY CLOSED

Port size	Orifice Ø	Flow factors			Operating Pressure Differential			Fluid Temp.		Seat Seal	Parker Valves			Power		Coil Group	Dwg. No.
		Kv l/min	KV m³/h	Qn l/min	Min bar	Max(MOPD) AC bar	DC bar	Min °C	Max °C		Valve Ref.	Housing Ref.	Coil Ref.	AC W	DC W		
1"	24	105	6.3	-	0	10	-	-10	85	EPDM	221S25E	2995	481865	8	-	2.0	070
	24	105	6.3	-	0	10	7	-10	140	EPDM	221S25E ₁	4270	486265	14	14	2.0	070
	24	105	6.3	-	0	10	-	-10	85	FKM	221S25F	2995	481865	8	-	2.0	070
	24	105	6.3	-	0	10	7	-10	85	FKM	221S25F ₁	4270	486265	14	14	2.0	070

Notes:

1. Maximum pressure for steam: 4 Bar (140°C)



For this page	Port size	Orifice (mm)	Kv (l/min)	MOPD (bar)	Fluid Temp (°C)	Amb Temp (°C)
From	1"	24	105	7	-10	-10
To	1"	24	105	10	140	50

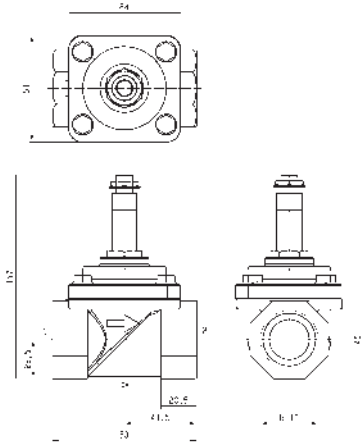

Drawing 070

2 WAY VALVES

OIL BURNER VALVES



2/2

Actuation	Body	Function	Port Size	Orifice (mm)	Flow Factor Kv(l/min)	MOPD (bar)	Max Fluid Temp. (°C)	Page Parker Valves	Page Parker LUCIFER® Valves
Direct Operated	Brass/Pipe mounting	Normally Closed	1/8"	1.7 to 4	5.3	30	160	178	184
			1/4"	2.5 to 4	6.5	30	160	180	184
			3/8"	5 to 11	22	30	160	182	184
			1/2"	5 to 14	25	30	160	182	184
	Brass/Pipe mounting	Normally Open	1/8"	2.5 to 3	4	30	160	186	188
			1/4"	2.5 to 3	4	30	160	186	188
	Brass/Sub-base mounting	Normally Closed	14 mm	14	25	30	160	-	188
Magnalift	Brass/Pipe mounting	Normally Closed	1/2"	15	50	5	140	-	190
Pilot Operated	Brass/Pipe mounting	Normally Closed	1/4"	8	36	40	140	-	192
			3/8"	11	50	40	160	-	192
			1/2"	15	60	40	160	-	194
Pilot Operated	Brass/Sub-base mounting	Normally Closed	14 mm	14	45	30	160	-	194

2/2

OIL BURNER VALVES DIRECT OPERATED



Heating Systems



Commercial Equipment

BRASS PIPE MOUNTING

NORMALLY CLOSED

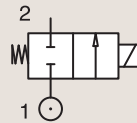

Port size	Orifice Ø	Flow factors			Operating Pressure Differential			Fluid Temp.		Seat Seal	Parker Valves			Power		Coil Group	Dwg. No.	
		Kv	KV	Qn	Min	Max(MOPD)	Min	Max	Valve Order Number		Valve Type	Coil Type	AC W	DC W				
BSP	mm	l/min	m³/h	m³/h	bar	AC bar	DC bar	°C	°C									
1/8"	1.7	1.4	0.086	-	0	25	-	-10	90	NBR	390034 ₂	131IN	KT09	110-120/60	9	-	22.0	015
	1.7	1.4	0.086	-	0	25	-	-10	90	NBR	390085 ₂	131IN	KT09	208-230/60	9	-	22.0	015
	1.7	1.4	0.086	-	0	25	-	-10	90	NBR	390005 ₂	131IN	KT09	24/50	9	-	22.0	015
	1.7	1.4	0.086	-	0	-	22	-10	90	NBR	390120 ₂	131IN	KT10	24 DC	-	10	22.0	015
	1.7	1.4	0.086	-	0	25	-	-10	90	NBR	390300 ₁₂	131INDIN	XT09	230/50	9	-	22.0	015
	1.7	1.4	0.086	-	0	25	-	-10	90	FKM	390086 ₂	131IV	KT09	208-230/60	9	-	22.0	015
	1.7	1.4	0.086	-	0	25	-	-10	90	FKM	390088 ₁₂	131IV	KT09	230/50	9	-	22.0	015
	1.7	1.4	0.086	-	0	25	-	-10	90	FKM	390089 ₂	131IV	KT09	240/50	9	-	22.0	015
	2.2	2	0.12	-	0	15	-	-10	90	NBR	390216 ₂	131AN	KT09	208-230/60	9	-	22.0	015
	2.2	2	0.12	-	0	15	-	-10	90	NBR	390165 ₂	131AN	KT09	230/50	9	-	22.0	015
	2.2	2	0.12	-	0	15	-	-10	90	NBR	390145 ₂	131AN	KT09	24/50	9	-	22.0	015
	2.2	2	0.12	-	0	-	13	-10	90	NBR	390195 ₂	131AN	KT10	12 DC	-	10	22.0	015
	2.2	2	0.12	-	0	-	13	-10	90	NBR	390215 ₂	131AN	KT10	24 DC	-	10	22.0	015
	2.5	3.2	0.192	-	0	30	-	-30	140	Ruby	362496J	PM140IR	ZB09		9	-	20.1/20.2	027
	2.5	3.2	0.192	-	0	-	17	-30	140	Ruby	362496J	PM140IR	ZB12		-	12	20.1/20.2	027
	2.8	2.9	0.174	-	0	8	-	-10	140	FKM	390445 ₂	131.4BV	KT09	115/50	9	-	22.0	012
	2.8	2.9	0.174	-	0	8	-	-10	140	FKM	390457 ₂	131.4BV	KT09	115/60	9	-	22.0	012
	2.8	2.9	0.174	-	0	8	-	-10	140	FKM	390458 ₂	131.4BV	KT09	208-230/60	9	-	22.0	012
2.8	2.9	0.174	-	0	8	-	-10	140	FKM	390465 ₂	131.4BV	KT09	230/50	9	-	22.0	012	
2.8	2.9	0.174	-	0	8	-	-10	140	FKM	390405 ₂	131.4BV	KT09	24/50	9	-	22.0	012	
2.8	2.9	0.174	-	0	-	6	-10	140	FKM	390495 ₂	131.4BV	KT10	12 DC	-	10	22.0	012	
2.8	2.9	0.174	-	0	-	6	-10	140	FKM	390505 ₂	131.4BV	KT10	24 DC	-	10	22.0	012	

Notes:

- DIN-EN-ISO 23553-1 (2009-10) approved for oil burners
- Ordering number is for an assembled valve and coil, with the voltage shown.



For this page	Port size	Orifice (mm)	Kv (l/min)	MOPD (bar)	Fluid Temp (°C)	Amb Temp (°C)
From	1/8"	1.7	1.4	6	-30	-10
To	1/8"	2.8	3.2	30	140	50

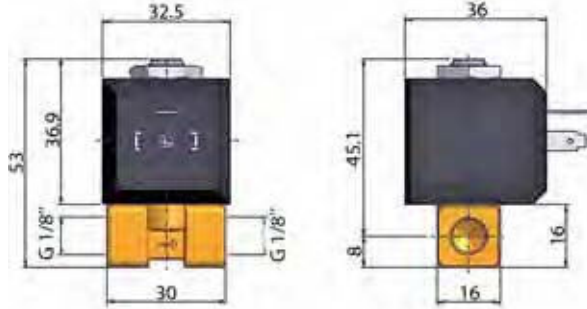

Drawing 015

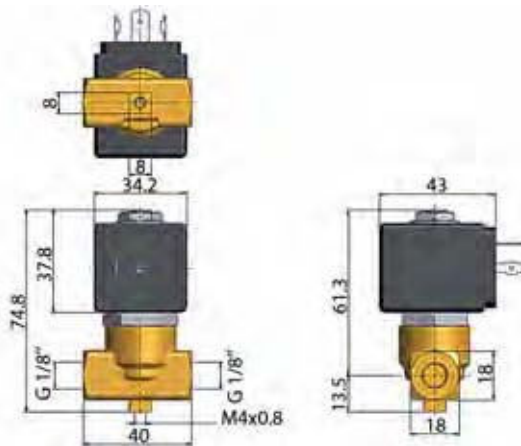

Drawing 027

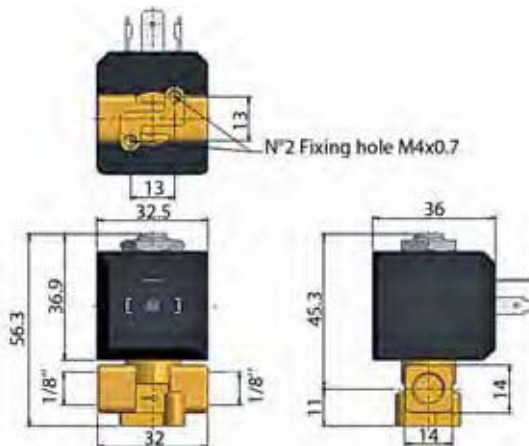

Drawing 012

2/2

OIL BURNER VALVES DIRECT OPERATED

BRASS

PIPE MOUNTING

NORMALLY CLOSED

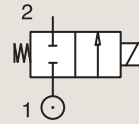

Port size	Orifice Ø	Flow factors			Operating Pressure Differential			Fluid Temp.		Seat Seal	Parker Valves			Power		Coil Group	Dwg. No.
		Kv	KV	Qn	Min	Max(MOPD)	DC bar	Min	Max		Valve Order Number	Valve Type	Coil Type	AC W	DC W		
BSP	mm	l/min	m³/h	m³/h	bar	AC bar	°C	°C									
1/8"	3	4	0.24	-	0	30	-	-30	140	Ruby	362510J ₁	PM140.4AR	ZH14	14	-	20.2	025
	4	5.3	0.318	-	0	2	-	-10	90	NBR	390874 ₂	131.4CG	KT09 115/50	9	-	22.0	013
	4	5.3	0.318	-	0	2	-	-10	90	NBR	390813 ₂	131.4CG	KT09 115/60	9	-	22.0	013
	4	5.3	0.318	-	0	2	-	-10	90	NBR	390878 ₂	131.4CG	KT09 230/50	9	-	22.0	013
	4	5.3	0.318	-	0	2	-	-10	90	NBR	390805 ₂	131.4CG	KT09 24/50	9	-	22.0	013
	4	5.3	0.318	-	0	2	-	-10	90	NBR	390875 ₂	131.4CG	KT09 240/50	9	-	22.0	013
	4	5.3	0.318	-	0	-	1	-10	90	NBR	390803 ₂	131.4CG	KT10 12DC	-	10	22.0	013
	4	5.3	0.318	-	0	-	1	-10	90	NBR	390802 ₂	131.4CG	KT10 24 DC	-	10	22.0	013
1/4"	2.5	3.2	0.192	-	0	30	-	-30	140	Ruby	362518J ₁	PM140CR	ZB09	9	-	20.1/20.2	026
	2.5	3.2	0.192	-	0	-	17	-30	140	Ruby	362518J ₁	PM140CR	ZB12	-	12	20.1/20.2	026
	2.5	3.2	0.192	-	0	30	-	-30	140	Ruby	362518J ₁	PM140CR	ZH14	14	-	20.1/20.2	026
	2.5	3.2	0.192	-	0	-	17	-30	140	Ruby	362518J ₁	PM140CR	ZH16	-	16	20.1/20.2	026
	2.8	2.9	0.174	-	0	8	-	-10	140	FKM	390560 ₂	131.4FV	KT09 115/50	9	-	22.0	014
	2.8	2.9	0.174	-	0	8	-	-10	140	FKM	390560 ₂	131.4FV	KT09 115/60	9	-	22.0	014
	2.8	2.9	0.174	-	0	8	-	-10	140	FKM	390626 ₂	131.4FV	KT09 208-230/60	9	-	22.0	014
	2.8	2.9	0.174	-	0	8	-	-10	140	FKM	390580 ₂	131.4FV	KT09 230/50	9	-	22.0	014
	2.8	2.9	0.174	-	0	8	-	-10	140	FKM	390525 ₂	131.4FV	KT09 24/50	9	-	22.0	014
	2.8	2.9	0.174	-	0	-	6	-10	140	FKM	390605 ₂	131.4FV	KT10 12 DC	-	10	22.0	014
	2.8	2.9	0.174	-	0	-	6	-10	140	FKM	390625 ₂	131.4FV	KT10 24 DC	-	10	22.0	014
	3	4	0.24	-	0	30	-	-30	140	Ruby	362530J ₁	PM140.4DR	ZH14	14	-	20.0/20.1/20.2	026
	3	4	0.24	-	0	30	-	-30	140	Ruby	362524J	PM140DR	ZB09	9	-	20.1/20.2	026
	3	4	0.24	-	0	-	12	-30	140	Ruby	362524J	PM140DR	ZB12	-	12	20.1/20.2	026
	3	4	0.24	-	0	30	-	-30	140	Ruby	362524J	PM140DR	ZH14	14	-	20.1/20.2	026
	3	4	0.24	-	0	-	12	-30	140	Ruby	362524J	PM140DR	ZH16	-	16	20.1/20.2	026
	4	5.3	0.318	-	0	1	-	-10	90	NBR	390915 ₂	131.4GG	KT09 115/50	9	-	22.0	013
	4	5.3	0.318	-	0	1	-	-10	90	NBR	390945 ₂	131.4GG	KT09 230/50	9	-	22.0	013
4	5.3	0.318	-	0	1	-	-10	90	NBR	390895 ₂	131.4GG	KT09 24/50	9	-	22.0	013	
4	5.3	0.318	-	0	1	-	-10	90	NBR	390975 ₂	131.4GG	KT09 240/50	9	-	22.0	013	
4	5.3	0.318	-	0	-	1	-10	90	NBR	390995 ₂	131.4GG	KT10 12 DC	-	10	22.0	013	
4	5.3	0.318	-	0	-	1	-10	90	NBR	390997 ₂	131.4GG	KT10 24 DC	-	10	22.0	013	
4	5.3	0.318	-	0	2	-	-10	140	FKM	390668 ₂	131.4GV	KT09 115/50	9	-	22.0	014	
4	5.3	0.318	-	0	2	-	-10	140	FKM	390700 ₂	131.4GV	KT09 115/60	9	-	22.0	014	
4	5.3	0.318	-	1	2	-	-10	140	FKM	390725 ₂	131.4GV	KT09 208-230/60	9	-	22.0	014	

Notes:

1. DIN-EN-ISO 23553-1 (2009-10) approved for oil burners
2. Ordering number is for an assembled valve and coil, with the voltage shown.



For this page	Port size	Orifice (mm)	Kv (l/min)	MOPD (bar)	Fluid Temp (°C)	Amb Temp (°C)
From	1/8"	2.5	2.9	1	-30	-10
To	1/4"	4	5.3	30	140	50

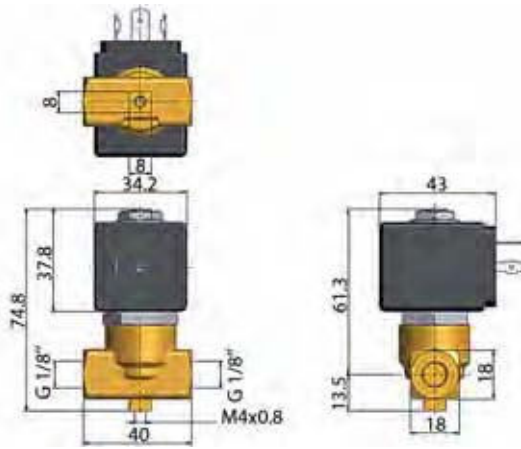

Drawing 025

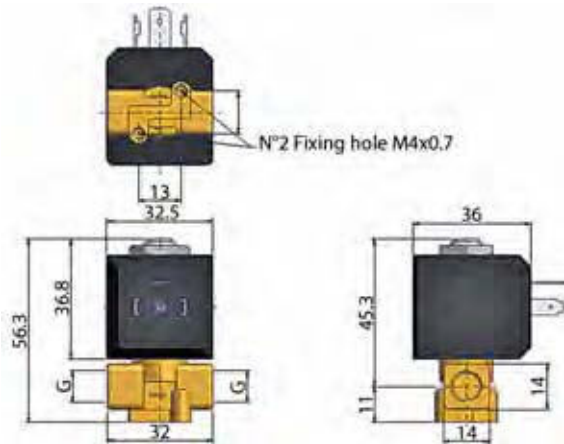

Drawing 013

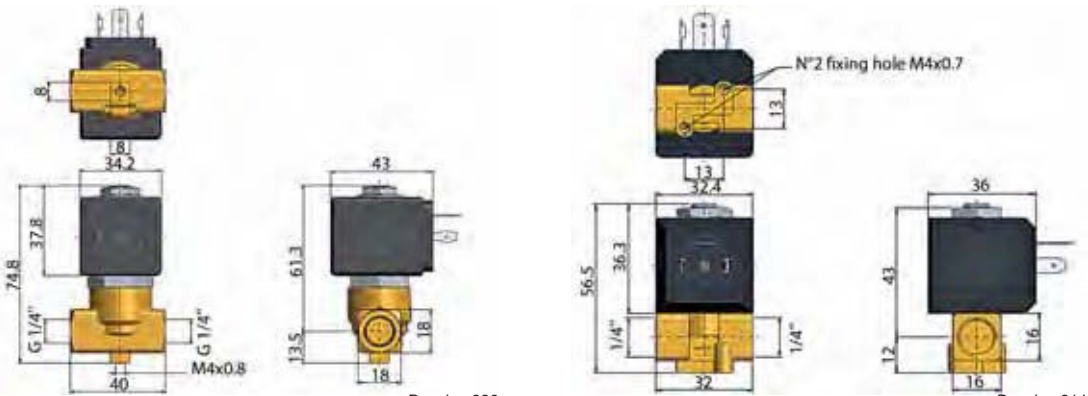

Drawing 026

Drawing 014

2/2

OIL BURNER VALVES DIRECT OPERATED

BRASS

PIPE MOUNTING

NORMALLY CLOSED

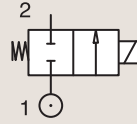

Port size	Orifice Ø	Flow factors			Operating Pressure Differential			Fluid Temp.		Seat Seal	Parker Valves			Power		Coil Group	Dwg. No.
		Kv l/min	KV m³/h	Qn m³/h	Min bar	Max(MOPD) AC bar	DC bar	Min °C	Max °C		Valve Order Number	Valve Type	Coil Type	AC W	DC W		
1/4"	4	5.3	0.318	-	0	2	-	-10	140	FKM	390705 ₁	131.4GV	KT09 230/50	9	-	22.0	014
	4	5.3	0.318	-	0	2	-	-10	140	FKM	390650 ₁	131.4GV	KT09 24/50	9	-	22.0	014
	4	5.3	0.318	-	0	2	-	-10	140	FKM	390718 ₁	131.4GV	KT09 240/50	9	-	22.0	014
	4	5.3	0.318	-	0	-	1	-10	140	FKM	390720 ₁	131.4GV	KT10 12 DC	-	10	22.0	014
	4	5.3	0.318	-	0	-	1	-10	140	FKM	390721 ₁	131.4GV	KT10 24 DC	-	10	22.0	014
3/8"	5	10	0.612	-	0	5	-	-10	140	FKM	364010	PM153BV	ZB14	14	-	20.2/22.0	037
	5	10	0.612	-	0	-	1.5	-10	140	FKM	364010	PM153BV	ZB16	-	16	20.2/22.0	037
1/2"	5	10	0.612	-	0	5	-	-10	140	FKM	364035	PM153GV	ZB14	14	-	20.2/22.0	037
	5	10	0.612	-	0	-	1.5	-10	140	FKM	364035	PM153GV	ZB16	-	16	20.2/22.0	037

Notes:

1. Ordering number is for an assembled valve and coil, with the voltage shown.



For this page	Port size	Orifice (mm)	Kv (l/min)	MOPD (bar)	Fluid Temp (°C)	Amb Temp (°C)
From	1/4"	4	5.3	1	-10	-10
To	1/2"	5	10	5	140	50

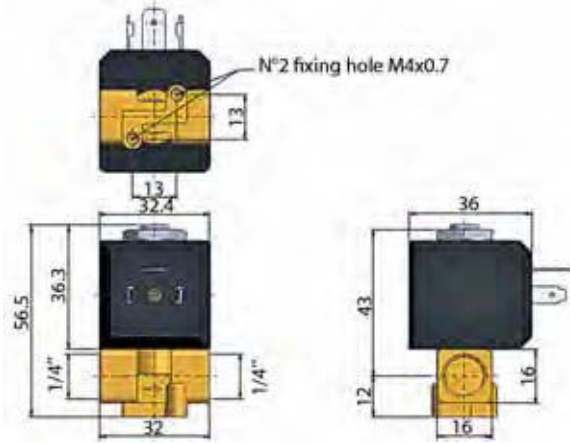

Drawing 014

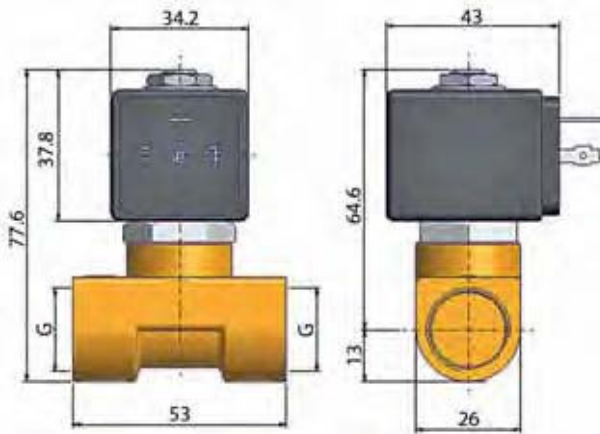

Drawing 037

2/2

OIL BURNER VALVES DIRECT OPERATED

BRASS
PIPE MOUNTING

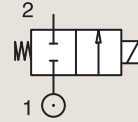

NORMALLY CLOSED

Port size	Orifice Ø	Flow factors			Operating Pressure Differential			Fluid Temp.		Seat Seal	Parker LUCIFER® Valves			Power		Coil Group	Dwg. No.
		Kv l/min	KV m³/h	Qn l/min	Min bar	AC bar	DC bar	Min °C	Max °C		Valve Ref.	Housing Ref.	Coil Ref.	AC W	DC W		
1/8"	3	4	0.24	-	0	30	-	-30	160	Ruby	121K2423 ¹³	8520.23	483824	19	-	14.1	3292
	3	4.5	0.27	-	0	30	-	-30	160	Ruby	121K6423 ¹³	8520.23	483824	19	-	14.1	3292
1/4"	4	6.5	0.39	-	0	30	-	0	160	Ruby	121K6220 ¹³	8520.23	483541	20	-	14.3	3510
	6	12	0.72	0	0	5	-	0	120	Ruby	121K3321	2995	492425	14	-	14.1	3551
3/8"	11	22	1.32	-	0	30	-	0	160	FKM	121G2320 ¹²³	8520.23	483541	20	-	14.3	3646
	14	25	1.5	-	0	30	-	0	160	FKM	121G2520 ¹²³	8520.23	483541	20	-	14.3	3646
1/2"	14	25	1.5	-	0	30	-	0	160	FKM	121G2523 ¹²³	8520.23	483824	19	-	14.1	3646

Notes:

1. DIN-EN-ISO 23553-1 (2009-10) approved for oil burners
2. Max. Static pressure = 30 bar; max pressure differential = 0.2 bar
3. Valve only compatible with hydraulic oil and neutral liquids

VALVE	A
121K2423	B 3/2P
121K6220	C 1/2S

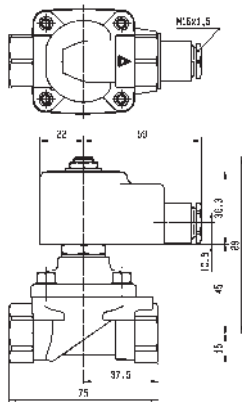
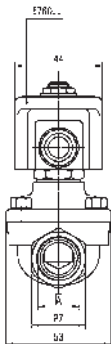

Drawing 3646



For this page	Port size	Orifice (mm)	Kv (l/min)	MOPD (bar)	Fluid Temp (°C)	Amb Temp (°C)
From	1/8"	3	4	5	-30	0
To	1/2"	14	25	30	160	60

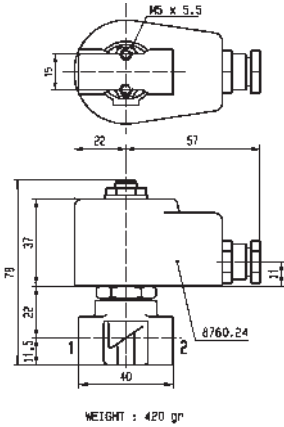

A	G 1/8"
	G 1/4"

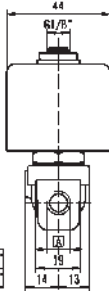

Drawing 3292

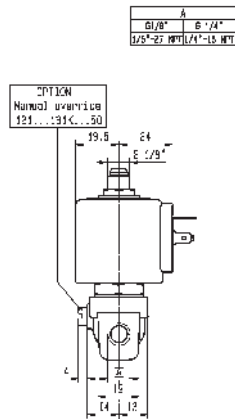
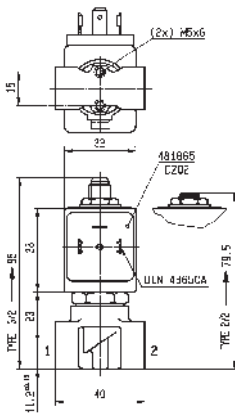

Drawing 3510

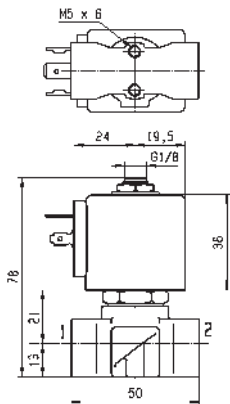

WEIGHT : 215 gr

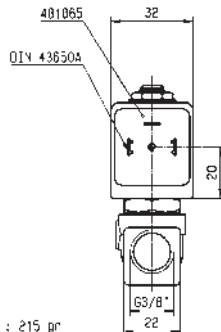

Drawing 3551

2/2

OIL BURNER VALVES DIRECT OPERATED

BRASS

PIPE MOUNTING

NORMALLY OPEN

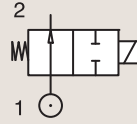

Port size	Orifice Ø	Flow factors			Operating Pressure Differential			Fluid Temp.		Seat Seal	Parker Valves			Power		Coil Group	Dwg. No.
		Kv l/min	KV m³/h	Qn m³/h	Min bar	Max(MOPD) AC bar	DC bar	Min °C	Max °C		Valve Order Number	Valve Type	Coil Type	AC W	DC W		
1/8"	3	4	0.24	-	0	30	-	-30	160	Ruby	360451J	PM120.4IR	ZB14	14	-	20.2	001
	3	4	0.24	-	0	30	-	-30	160	Ruby	360451J ₁	PM120.4IR	ZH14	14	-	20.2	001
1/4"	3	4	0.24	-	0	30	-	-30	160	Ruby	360452J	PM120.4AR	ZB14	14	-	20.2	001
	3	4	0.24	-	0	30	-	-30	160	Ruby	360452J ₁	PM120.4AR	ZH14	14	-	20.2	001

Notes:

1. DIN-EN-ISO 23553-1 (2009-10) approved for oil burners



For this page	Port size	Orifice (mm)	Kv (l/min)	MOPD (bar)	Fluid Temp (°C)	Amb Temp (°C)
From	1/8"	3	4	30	-30	-10
To	1/4"	3	4	30	160	50

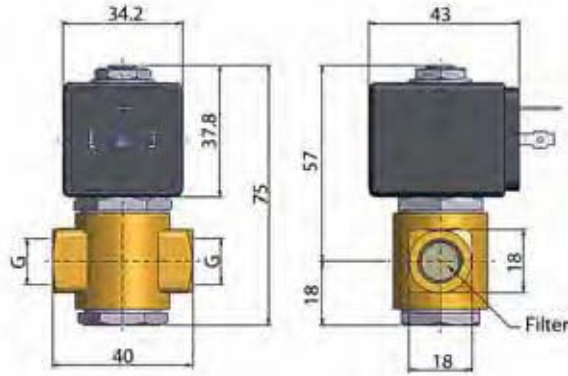

Drawing 001

2/2

OIL BURNER VALVES
DIRECT OPERATED

BRASS

PIPE MOUNTING

NORMALLY OPEN

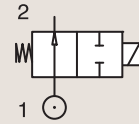

Port size	Orifice Ø	Flow factors			Operating Pressure Differential			Fluid Temp.		Seat Seal	Parker LUCIFER® Valves			Power		Coil Group	Dwg. No.
		Kv l/min	KV m³/h	Qn l/min	Min bar	Max(MOPD) AC bar	DC bar	Min °C	Max °C		Valve Ref.	Housing Ref.	Coil Ref.	AC W	DC W		
1/8"	2.5	3.5	0.21	-	0	30	-	-30	160	Ruby	122K9321	8520.23	483824	19	-	14.1	6766
1/4"	2.5	3.5	0.21	-	0	30	-	-30	160	Ruby	122K8321	8520.23	483824	19	-	14.1	6766

Notes:

1. DIN-EN-ISO 23553-1 (2009-10) approved for oil burners

BRASS

SUB-BASE MOUNTING

NORMALLY CLOSED

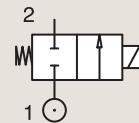

Port size	Orifice Ø	Flow factors			Operating Pressure Differential			Fluid Temp.		Seat Seal	Parker LUCIFER® Valves			Power		Coil Group	Dwg. No.
		Kv l/min	KV m³/h	Qn l/min	Min bar	Max(MOPD) AC bar	DC bar	Min °C	Max °C		Valve Ref.	Housing Ref.	Coil Ref.	AC W	DC W		
SB	14	25	1.5	-	0	30	-	0	160	FKM	121F2523	8520.23	483824	19	-	14.1	7638

Notes:

1. DIN-EN-ISO 23553-1 (2009-10) approved for oil burners



For this page	Port size	Orifice (mm)	Kv (l/min)	MOPD (bar)	Fluid Temp (°C)	Amb Temp (°C)
From	1/8"	2.5	3.5	30	-30	0
To	14 mm	14	25	30	160	60

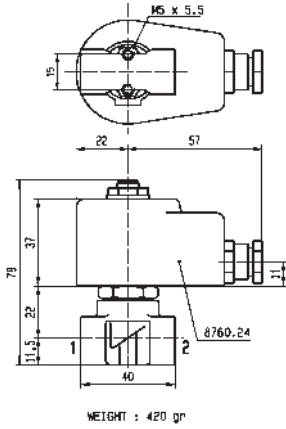

A	G 1/8"
	G 1/4"

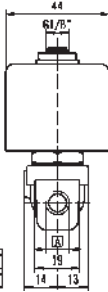

Drawing 6766

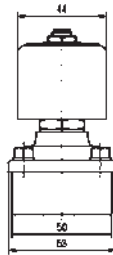
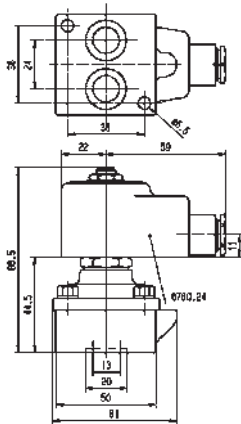

Drawing 7638

2/2

OIL BURNER VALVES MAGNALIFT



Heating Systems

BRASS
PIPE MOUNTING

NORMALLY CLOSED

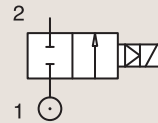

Port size	Orifice Ø	Flow factors			Operating Pressure Differential			Fluid Temp.		Seat Seal	Parker LUCIFER® Valves			Power		Coil Group	Dwg. No.
		Kv l/min	KV m³/h	Qn l/min	Min bar	Max(MOPD) AC bar	DC bar	Min °C	Max °C		Valve Ref.	Housing Ref.	Coil Ref.	AC W	DC W		
1/2"	15	50	3	0	0	5	-	0	140	FKM	221G2523 ₁	8520.25	483824	19	-	14.1	8298

Notes:

1. DIN-EN-ISO 23553-1 (2009-10) approved for oil burners



For this page	Port size	Orifice (mm)	Kv (l/min)	MOPD (bar)	Fluid Temp (°C)	Amb Temp (°C)
From	1/2"	15	50	5	0	0
To	1/2"	15	50	5	140	60

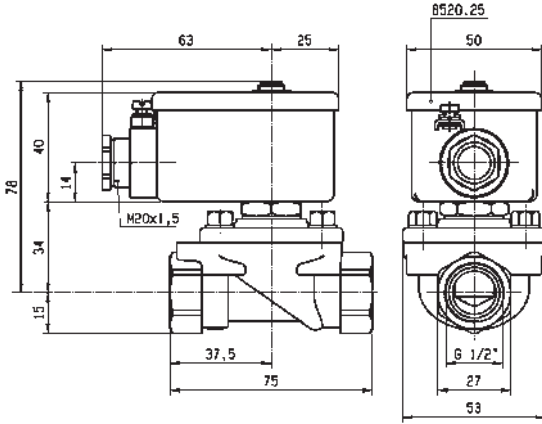

Drawing 8298

2/2

OIL BURNER VALVES PILOT OPERATED



Commercial Equipment



Industrial Equipment



Heating Systems

BRASS PIPE MOUNTING

NORMALLY CLOSED

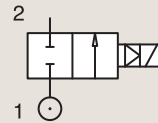

Port size	Orifice Ø	Flow factors			Operating Pressure Differential			Fluid Temp.		Seat Seal	Parker LUCIFER® Valves			Power		Coil Group	Dwg. No.
		Kv l/min	KV m³/h	Qn l/min	Min bar	Max(MOPD) AC bar	DC bar	Min °C	Max °C		Valve Ref.	Housing Ref.	Coil Ref.	AC W	DC W		
1/4"	8	36	2.16	-	0.3	40	25	-10	100	FKM	E321H21 ²³⁴	2995	481865	8	9	2.0	3523
	8	36	2.16	-	0.3	40	30	-10	120	FKM	E321H21 ²³⁴	4270	481000	8	8	2.0	3523
	8	36	2.16	-	0.3	40	40	-10	140	FKM	E321H21 ²³⁴	4270	486265	14	14	2.0	3523
3/8"	11	40	2.4	-	0.3	30	-	0	160	Ruby	321H2322 ¹²⁴	8520.23	483541	20	-	14.3	3633
	11	50	3	-	0.3	40	25	-10	100	FKM	E321H23 ²³⁴	2995	481865	8	9	2.0	3521
	11	50	3	-	0.3	40	30	-10	120	FKM	E321H23 ²³⁴	4270	481000	8	8	2.0	3521
	11	50	3	-	0.3	40	40	-10	140	FKM	E321H23 ²³⁴	4270	486265	14	14	2.0	3521

Notes:

1. DIN-EN-ISO 23553-1 (2009-10) approved for oil burners
2. Minimum pressure differential = 0.3 bar for opening and 0 bar for closing
3. Pilot seat disc in synthetic Ruby
4. Valve only compatible with hydraulic oil and neutral liquids



For this page	Port size	Orifice (mm)	Kv (l/min)	MOPD (bar)	Fluid Temp (°C)	Amb Temp (°C)
From	1/4"	8	36	25	-10	-10
To	3/8"	11	50	40	160	50

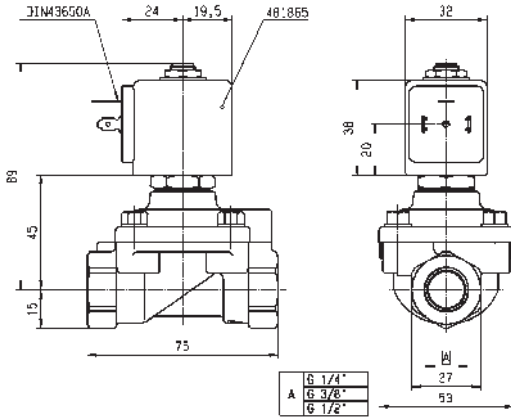

Drawing 3523

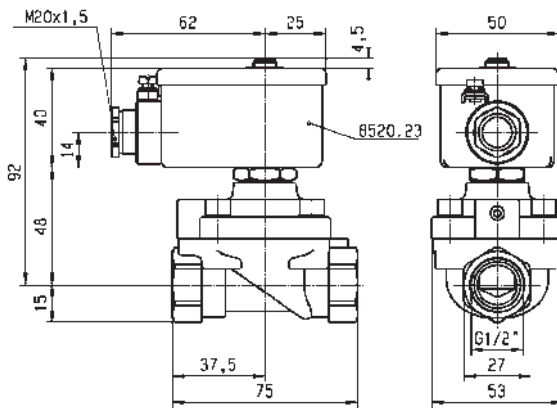

Drawing 3633

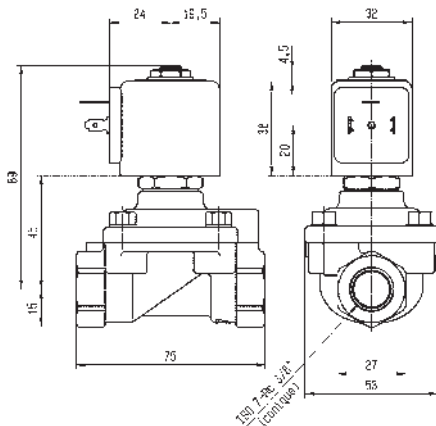

Drawing 3521

2/2

OIL BURNER VALVES PILOT OPERATED

BRASS

PIPE MOUNTING

NORMALLY CLOSED

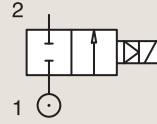

Port size	Orifice Ø	Flow factors			Operating Pressure Differential			Fluid Temp.		Seat Seal	Parker LUCIFER® Valves			Power		Coil Group	Dwg. No.
		Kv l/min	KV m³/h	Qn l/min	Min bar	Max(MOPD) AC bar	DC bar	Min °C	Max °C		Valve Ref.	Housing Ref.	Coil Ref.	AC W	DC W		
1/2"	15	60	3.6	-	0.3	30	-	0	160	Ruby	321H2522 ¹⁴	8520.23	483541	20	-	14.3	3633
	15	60	3.6	-	0.3	30	-	0	160	Ruby	321H2523 ¹⁴	8520.23	483824	19	-	14.1	3633
	15	60	3.6	-	0.3	40	25	-10	100	FKM	E321H25 ²³⁴	2995	481865	8	9	2.0/14.2	3522
	15	60	3.6	-	0.3	40	30	-10	120	FKM	E321H25 ²³⁴	-	483371	8	8	2.0/14.2	3522
	15	60	3.6	-	0.3	40	40	-10	140	FKM	E321H25 ²³⁴	4270	486265	14	14	2.0/14.2	3522

Notes:

1. DIN-EN-ISO 23553-1 (2009-10) approved for oil burners
2. Minimum pressure differential = 0.3 bar for opening and 0 bar for closing
3. Pilot seat disc in synthetic Ruby
4. Valve only compatible with hydraulic oil and neutral liquids

BRASS

SUB-BASE MOUNTING

NORMALLY CLOSED

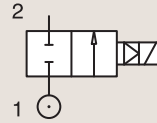

Port size	Orifice Ø	Flow factors			Operating Pressure Differential			Fluid Temp.		Seat Seal	Parker LUCIFER® Valves			Power		Coil Group	Dwg. No.
		Kv l/min	KV m³/h	Qn l/min	Min bar	Max(MOPD) AC bar	DC bar	Min °C	Max °C		Valve Ref.	Housing Ref.	Coil Ref.	AC W	DC W		
SB	14	45	2.7	-	0	30	-	0	160	FKM	321F2523 ¹²	8520.23	483824	19	-	14.1	7639

Notes:

1. DIN-EN-ISO 23553-1 (2009-10) approved for oil burners
2. Minimum pressure differential = 0.3 bar for opening and 0 bar for closing



For this page	Port size	Orifice (mm)	Kv (l/min)	MOPD (bar)	Fluid Temp (°C)	Amb Temp (°C)
From	1/2"	14	45	25	-10	-10
To	14 mm	15	60	40	160	50

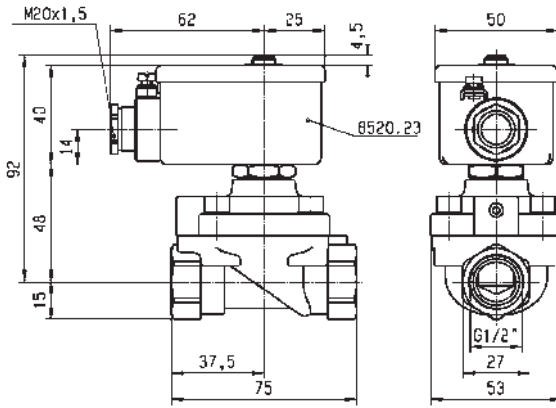

Drawing 3633

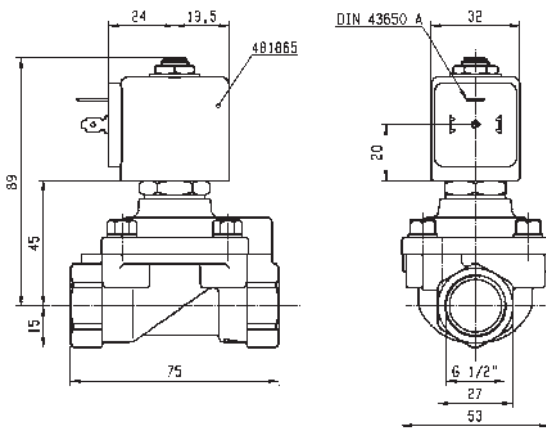

Drawing 3522

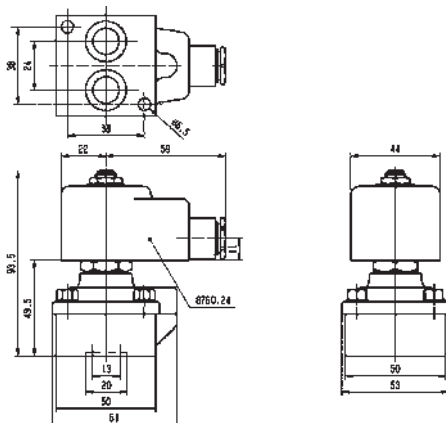

Drawing 7639

2 WAY VALVES

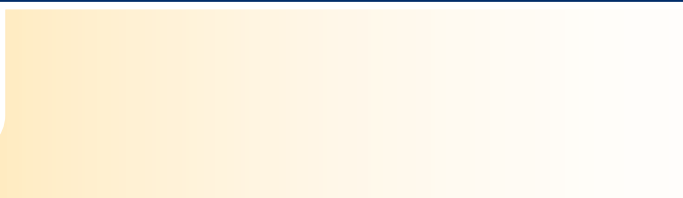

FAST SWITCHING VALVES



2/2

Actuation	Body	Function	Port Size	Orifice (mm)	Flow Factor Kv(l/min)	MOPD (bar)	Max Fluid Temp. (°C)	Page Parker Valves	Page Parker LUCIFER® Valves
Magnalift	Brass/Pipe mounting	Normally Closed	3/8"	8	0	7	40	-	198

2/2

FAST SWITCHING VALVES MAGNALIFT



Industrial Equipment

BRASS
PIPE MOUNTING

NORMALLY CLOSED

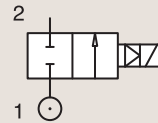

Port size	Orifice Ø	Flow factors			Operating Pressure Differential			Fluid Temp.		Seat Seal	Parker LUCIFER® Valves			Power		Coil Group	Dwg. No.
		Kv l/min	KV m³/h	Qn l/min	Min bar	Max(MOPD) AC bar	DC bar	Min °C	Max °C		Valve Ref.	Housing Ref.	Coil Ref.	AC W	DC W		
3/8"	8	-	-	-	0	-	7	0	40	PUR	221J3301E ₁	2995.6	483816	-	14		8020

Notes:

1. For more details, please consult catalogue 8674UK

Flow rate (valve on 100%)

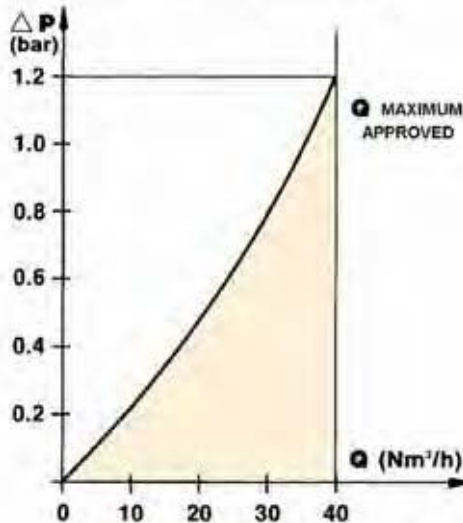



For this page	Port size	Orifice (mm)	Kv (l/min)	MOPD (bar)	Fluid Temp (°C)	Amb Temp (°C)
From	3/8"	8	-	7	0	0
To	3/8"	8	-	7	40	50

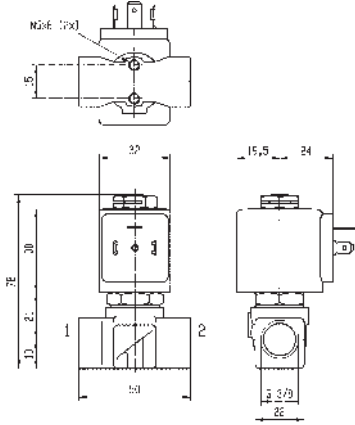

Drawing 8020

2 WAY VALVES





VALVES FOR BEVERAGE DISPENSING - LIQUIPURE®



2/2

Actuation	Body	Function	Port Size	Orifice (mm)	Flow Factor Kv(l/min)	MOPD (bar)	Max Fluid Temp. (°C)	Page Parker Valves
Direct Operated	Stainless St./Sub-base mounting	Normally Closed	SB	1.5 to 3	4.2	20	-	202

2/2

VALVES FOR BEVERAGE DISPENSING - LIQUIPURE® DIRECT OPERATED



Beverage Dispensing



Medical / Instrumentation

STAINLESS ST. SUB-BASE MOUNTING

NORMALLY CLOSED

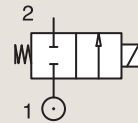

Port size	Orifice Ø mm	Flow factors			Operating Pressure Differential			Fluid Temp.		Seat Seal	Valve Ref.	Parker Valves		Power		Coil Group	Dwg. No.
		Kv l/min	KV m³/h	Qn l/min	Min bar	Max(MOPD)		Min °C	Max °C			Housing Ref.	Coil Ref.	AC W	DC W		
						AC bar	DC bar										
SB	1.5	1.3	0.08	-	0	20	20	-10	140	Ruby	2019F1GRG7	-	D4	13	16	24.0	071
	1.5	1.3	0.08	-	0	20	20	-10	140	Ruby	2019F1GRG7	-	D5	8	9	24.0	071
	1.5	1.3	0.08	-	0	20	20	-10	140	Ruby	2019F1GRG7	-	LA	9	9	24.0	071
	1.5	1.3	0.08	-	0	20	20	-10	140	Ruby	2019F1GRG7	-	LB-LC	13	16	24.0	071
	1.5	1.3	0.08	-	0	20	-	-10	140	Ruby	2019F1GRG7	-	XS03	9	-	24.0	071
	1.5	1.3	0.08	-	0	20	20	-10	140	FDA FKM	2019F1GVG7	-	D4	13	16	24.0	071
	1.5	1.3	0.08	-	0	20	20	-10	140	FDA FKM	2019F1GVG7	-	D5	8	9	24.0	071
	1.5	1.3	0.08	-	0	20	20	-10	140	FDA FKM	2019F1GVG7	-	LA	9	9	24.0	071
	1.5	1.3	0.08	-	0	20	20	-10	140	FDA FKM	2019F1GVG7	-	LB-LC	13	16	24.0	071
	1.5	1.3	0.08	-	0	20	-	-10	140	FDA FKM	2019F1GVG7	-	XS03	9	-	24.0	071
	2	2.3	0.14	-	0	15	15	-10	140	Ruby	2019F1JRG7	-	D4	13	16	24.0	071
	2	2.3	0.14	-	0	15	15	-10	140	Ruby	2019F1JRG7	-	D5	8	9	24.0	071
	2	2.3	0.14	-	0	15	15	-10	140	Ruby	2019F1JRG7	-	LA	9	9	24.0	071
	2	2.3	0.14	-	0	15	15	-10	140	Ruby	2019F1JRG7	-	LB-LC	13	16	24.0	071
	2	2.3	0.14	-	0	15	-	-10	140	Ruby	2019F1JRG7	-	XS03	9	-	24.0	071
	2	2.3	0.14	-	0	15	15	-10	140	FDA FKM	2019F1JVG7	-	D4	13	16	24.0	071
	2	2.3	0.14	-	0	15	15	-10	140	FDA FKM	2019F1JVG7	-	D5	8	9	24.0	071
	2	2.3	0.14	-	0	15	15	-10	140	FDA FKM	2019F1JVG7	-	LA	9	9	24.0	071
	2	2.3	0.14	-	0	15	15	-10	140	FDA FKM	2019F1JVG7	-	LB-LC	13	16	24.0	071
	2	2.3	0.14	-	0	15	-	-10	140	FDA FKM	2019F1JVG7	-	XS03	9	-	24.0	071
2.5	3.2	0.19	-	0	10	10	-10	140	Ruby	2019F1LRG7	-	D4	13	16	24.0	071	
2.5	3.2	0.19	-	0	10	10	-10	140	Ruby	2019F1LRG7	-	D5	8	9	24.0	071	
2.5	3.2	0.19	-	0	10	10	-10	140	Ruby	2019F1LRG7	-	LA	9	9	24.0	071	
2.5	3.2	0.19	-	0	10	10	-10	140	Ruby	2019F1LRG7	-	LB-LC	13	16	24.0	071	



For this page	Port size	Orifice (mm)	Kv (l/min)	MOPD (bar)	Fluid Temp (°C)	Amb Temp (°C)
From	SB	1.5	1.3	10	-10	-10
To	SB	2.5	3.2	20	140	50



Drawing 071

2/2

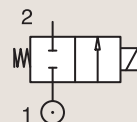
VALVES FOR BEVERAGE DISPENSING -
LIQUIPURE®
DIRECT OPERATEDSTAINLESS ST.
SUB-BASE MOUNTING

NORMALLY CLOSED

Port size	Orifice Ø mm	Flow factors			Operating Pressure Differential			Fluid Temp.		Seat Seal	Valve Ref.	Parker Valves		Power		Coil Group	Dwg. No.
		Kv l/min	KV m³/h	Qn l/min	Min bar	Max(MOPD)		Min °C	Max °C			Housing Ref.	Coil Ref.	AC W	DC W		
						AC bar	DC bar										
SB	2.5	3.2	0.19	-	0	10	-	-10	140	Ruby	2019F1LRG7	-	XS03	9	-	24.0	071
	2.5	3.2	0.19	-	0	10	10	-10	140	FDA FKM	2019F1LVG7	-	D4	13	16	24.0	071
	2.5	3.2	0.19	-	0	10	10	-10	140	FDA FKM	2019F1LVG7	-	D5	8	9	24.0	071
	2.5	3.2	0.19	-	0	10	10	-10	140	FDA FKM	2019F1LVG7	-	LA	9	9	24.0	071
	2.5	3.2	0.19	-	0	10	10	-10	140	FDA FKM	2019F1LVG7	-	LB-LC	13	16	24.0	071
	2.5	3.2	0.19	-	0	10	-	-10	140	FDA FKM	2019F1LVG7	-	XS03	9	-	24.0	071
	3	4.2	0.25	-	0	7	7	-10	140	Ruby	2019F1NRG7	-	D4	13	16	24.0	071
	3	4.2	0.25	-	0	7	7	-10	140	Ruby	2019F1NRG7	-	D5	8	9	24.0	071
	3	4.2	0.25	-	0	7	7	-10	140	Ruby	2019F1NRG7	-	LA	9	9	24.0	071
	3	4.2	0.25	-	0	7	7	-10	140	Ruby	2019F1NRG7	-	LB-LC	13	16	24.0	071
	3	4.2	0.25	-	0	7	-	-10	140	Ruby	2019F1NRG7	-	XS03	9	-	24.0	071
	3	4.2	0.25	-	0	7	7	-10	140	FDA FKM	2019F1NVG7	-	D4	13	16	24.0	071
	3	4.2	0.25	-	0	7	7	-10	140	FDA FKM	2019F1NVG7	-	D5	8	9	24.0	071
	3	4.2	0.25	-	0	7	7	-10	140	FDA FKM	2019F1NVG7	-	LA	9	9	24.0	071
	3	4.2	0.25	-	0	7	7	-10	140	FDA FKM	2019F1NVG7	-	LB-LC	13	16	24.0	071
	3	4.2	0.25	-	0	7	-	-10	140	FDA FKM	2019F1NVG7	-	XS03	9	-	24.0	071



For this page	Port size	Orifice (mm)	Kv (l/min)	MOPD (bar)	Fluid Temp (°C)	Amb Temp (°C)
From	SB	2.5	3.2	7	-10	-10
To	SB	3	4.2	10	140	50



Drawing 071

3 WAY VALVES

VALVES FOR DRY OR LUBRICATED AIR, NEUTRAL GASES AND LIQUIDS



3/2

Actuation	Body	Function	Port Size	Orifice (mm)	Flow Factor Kv(l/min)	MOPD (bar)	Max Fluid Temp. (°C)	Page Parker Valves	Page Parker LUCIFER® Valves	
Direct Operated	Brass/Pipe mounting	Normally Closed	1/8"	1.2 to 2.5	3.5	20	140	208		
			1/8"-1/4"	2.5	3.5	7	75	-	210	
			1/4"	1 to 4.5	7	30	140	208		
		Normally Open	1/4"	1.5 to 3	4.5	16	120	-	218	
			Universal	1/8"	1.5 to 2.5	3.5	10	140	220	
				1/4"	0.8 to 3.5	5	30	140	220	
	Brass/Sub-base mounting	Control by Electric Impulse	Normally Closed	1/4"	1.5	1.5	16	100	-	224
				SB	1.3	1	20	140	226	
				3.5 mm	1.2 to 1.5	0.9	10	75	-	228
		Normally Open	5 mm	1 to 2.5	3.5	16	120	-	228	
			Universal	5 mm	1.5 to 2.5	2.2	15	120	-	230
				1/8"-1/5"	1.5	1.5	10	120	-	232
Pilot Operated	Anodized aluminium/ Banjo	Normally Closed	1/8"	1.2	-	10	50	-	234	
			5 mm	1.5	1.5	15	100	-	236	
		Normally Open	3 mm	2	2	10	50	-	238	
			303 Stainless St./Sub-base mounting	Normally Closed	1/4"	6.5 to 8	20	15	75	-
	1/2"	14			-	15	75	-	242	
	POM/Sub-base mounting	Normally Open	1/4"	8	20	40	75	-	242	
1/2"			14	-	15	100	-	244		
Anodized aluminium/ Sub-base mounting/ Poppet		Normally Closed	1/2"	15	-	10	75	-	244	

3/2

VALVES FOR DRY OR LUBRICATED AIR, NEUTRAL GASES AND LIQUIDS
DIRECT OPERATED



Industrial Equipment



Commercial Equipment



Process

BRASS PIPE MOUNTING

NORMALLY CLOSED

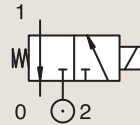

Port size	Orifice Ø		Flow factors			Operating Pressure Differential			Fluid Temp.		Seat Seal	Parker Valves			Power		Coil Group	Dwg. No.	
	1	(2)	1	(2)	1	(2)	Min	Max(MOPD)	Min	Max		Valve Order Number	Valve Type	Coil Type	AC W	DC W			
BSP	mm		Kv	l/min	KV	l/min	bar	AC bar	DC bar	°C	°C								
1/8"	1.2	1.6	0.7	-	0.04	-	0	8	-	-10	140	FKM	398102 ₁	N79.4IV	WB4.5 115/50-60	4.5	-	1.3	066
	1.2	1.6	0.7	-	0.04	-	0	14	-	-10	140	FKM	398104 ₁	N79.4IV	WB4.5 230/50-60	4.5	-	1.3	066
	1.2	1.6	0.7	-	0.04	-	0	14	-	-10	140	FKM	398120 ₁	N79.4IV	WB4.5 24/50-60	4.5	-	1.3	066
	1.2	1.6	0.7	-	0.04	-	0	14	-	-10	140	FKM	398100 ₁	N79.4IV	WB4.5 42/50-60	4.5	-	1.3	066
	1.5	1.6	1	-	0.06	-	0	8	-	-10	140	FKM	398112 ₁	N79.4AV	WB4.5 230/50-60	4.5	-	1.3	066
	1.5	1.6	1	-	0.06	-	0	8	-	-10	140	FKM	398122 ₁	N79.4AV	WB4.5 24/50-60	4.5	-	1.3	066
	1.5	1.6	1	-	0.06	-	0	8	-	-10	140	FKM	398138 ₁	N79.6AV	WB4.5 115/50-60	4.5	-	1.3	080
	1.5	1.6	1	-	0.06	-	0	8	-	-10	140	FKM	398130U ₁	N79.6AV	WB4.5 115/60	4.5	-	1.3	080
	1.5	1.6	1	-	0.06	-	0	8	-	-10	140	FKM	398114 ₁	N79.6AV	WB4.5 230/50-60	4.5	-	1.3	080
	1.5	1.6	1	-	0.06	-	0	8	-	-10	140	FKM	398142 ₁	N79.6AV	WB4.5 240/50-60	4.5	-	1.3	080
	1.5	1.5	1.2	-	0.07	-	0	20	-	-10	140	FKM	362560J	PM141AV	ZB09	9	-	20.1/20.2	029
	2	1.6	1.5	-	0.09	-	0	5	-	-10	140	FKM	398134U ₁	N79.6BV	WB4.5 115/60	4.5	-	1.3	080
	2	1.6	1.5	-	0.09	-	0	5	-	-10	140	FKM	398136U ₁	N79.6BV	WB4.5 208-240/60	4.5	-	1.3	080
	2	1.6	1.5	-	0.09	-	0	5	-	-10	140	FKM	398132 ₁	N79.6BV	WB4.5 230/50-60	4.5	-	1.3	080
2	2.5	2	-	0.12	-	0	15	-	-10	140	FKM	362570J	PM141BV	ZB09	9	-	20.1/20.2	029	
1/4"	2	2.5	2	-	0.12	-	0	15	-	-10	140	FKM	362620J	PM141FV	ZB09	9	-	20.1/20.2	033
	2.5	2.5	2.8	-	0.17	-	0	9	-	-10	140	FKM	362630J	PM141GV	ZB09	9	-	20.1/20.2	033

Notes:

1. Ordering number is for an assembled valve and coil, with the voltage shown.



For this page	Port size	Orifice (mm)	Kv (l/min)	MOPD (bar)	Fluid Temp (°C)	Amb Temp (°C)
From	1/8"	1.2	0.7	5	-10	-10
To	1/4"	2.5	2.8	20	140	50

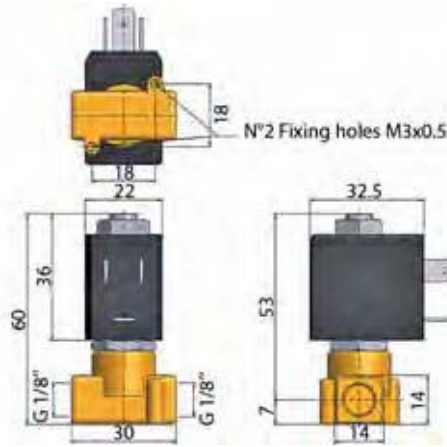

Drawing 066



Drawing 080

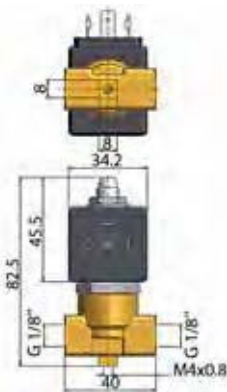

Drawing 029

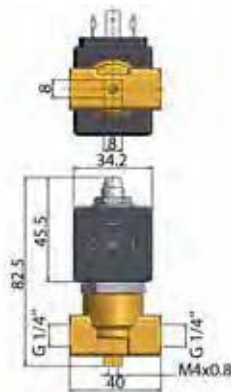

Drawing 033

3/2

VALVES FOR DRY OR LUBRICATED AIR, NEUTRAL GASES AND LIQUIDS
DIRECT OPERATED

BRASS

PIPE MOUNTING

NORMALLY CLOSED

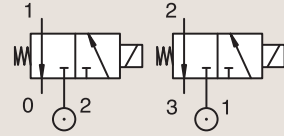

Port size	Orifice Ø		Flow factors			Operating Pressure Differential			Fluid Temp.		Seat Seal	Parker LUCIFER® Valves			IS	Power		Coil Group	Dwg. No.	
	1	(2)	1	(2)	1	(2)	Min	Max (MOPD)	Min	Max		Valve Ref.	Housing Ref.	Coil Ref.		AC W	DC W			
BSP	mm		Kv		KV		bar	AC bar	DC bar	°C	°C									
1/8"	1.2	1.5	0.7	0.9	0.04	0.05	0	10	10	-10	75	FKM	131M15	8993	488980	2	2.5	1.1	3382	
	1.5	1.5	0.9	0.9	0.05	0.05	0	7	7	-10	75	FKM	131M14	8993	488980	2	2.5	1.1	3382	
	1.5	1.5	1.5	1.5	0.09	0.09	0	15	15	-10	120	FKM	E131K14	4270	481000	8	8	2.1	3510	
	1.5	1.5	1.5	1.5	0.09	0.09	0	15	15	-10	100	FKM	E131K14	2995	481865	8	9	2.1	3510	
	2	2.5	2.5	3.5	0.15	0.21	0	10	10	-10	120	FKM	131K16	4270	481000	8	8	2.1	3510	
	2	2.5	2.5	3.5	0.15	0.21	0	10	10	-10	100	FKM	131K16	2995	481865	8	9	2.1	3510	
	2	2.5	2.5	3.5	0.15	0.21	0	10	10	-10	120	FKM	131K1650 ₁	4270	481000	8	8	2.1	3510	
	2	2.5	2.5	3.5	0.15	0.21	0	10	10	-10	100	FKM	131K1650 ₁	2995	481865	8	9	2.1	3510	
	2.5	2.5	3.5	3.5	0.21	0.21	0	7	7	-10	120	FKM	E131K13	4270	481000	8	8	2.0	3510	
	2.5	2.5	3.5	3.5	0.21	0.21	0	7	7	-10	100	FKM	E131K13	2995	481865	8	9	2.0	3510	
1/8"-1/4"	2.5	2.5	3	3	0.18	0.18	0	-	2	-20	75	PUR	131K0397	2995	482740	-	1.6	6.0/8.0	8023	
	2.5	2.5	3	3	0.18	0.18	0	2	2	-20	75	PUR	131K0397	-	495900	2.5	2	6.0/8.0	8023	
	2.5	2.5	3	3	0.18	0.18	0	-	2	-20	75	PUR	131K0397	-	495910	*	-	0.3 to 3	6.0/8.0	8023
	2.5	2.5	3.5	3.5	0.21	0.21	0	7	7	-40	75	PUR	E131K0358 ₁	4270	481000	8	8	2.1	3510	
	2.5	2.5	3.5	3.5	0.21	0.21	0	7	7	-40	75	PUR	E131K0358 ₁	2995	481865	8	9	2.1	3510	
1/4"	1	1	0.6	0.6	0.03	0.03	0	-	10	-10	55	FKM	131K0490	2995	483580.01	*	-	0.5 to 3	7.0/8.0	7058
	1	1	0.6	0.6	0.03	0.03	0	-	10	-10	75	FKM	131K0490	-	488660.01	*	-	0.3 to 3	7.0/8.0	7058
	1	1	0.6	-	0.03	-	0	-	10	-10	75	FKM	131K0490	-	495910	*	-	0.3 to 3	7.0/8.0	7058

Notes:

1. With manual override

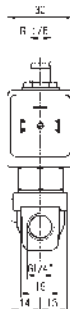
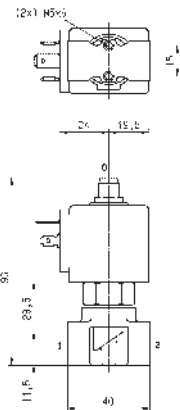

Drawing 7058



For this page	Port size	Orifice (mm)	Kv (l/min)	MOPD (bar)	Fluid Temp (°C)	Amb Temp (°C)
From	1/8"	1	0.6	2	-40	-40
To	1/4"	2.5	3.5	15	120	50

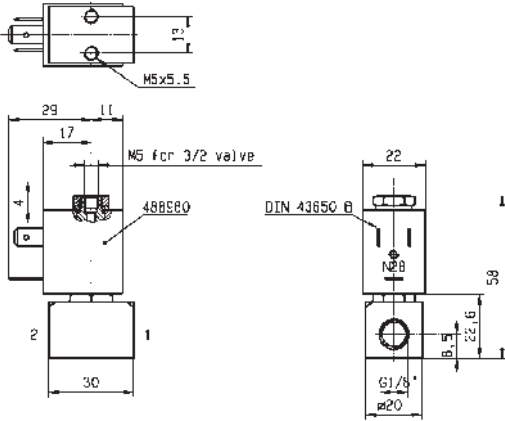

Drawing 3382

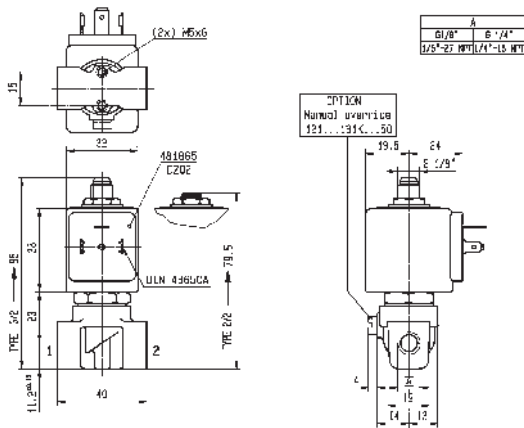

Drawing 3510

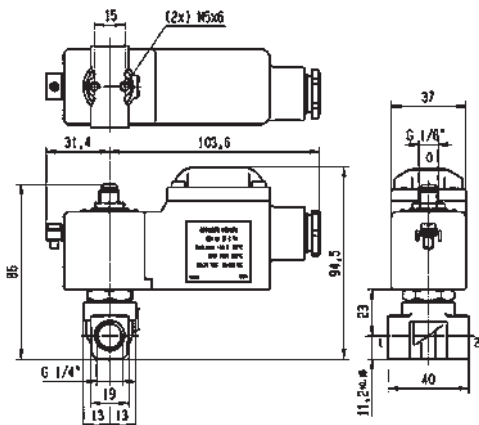

Drawing 8023

3/2

VALVES FOR DRY OR LUBRICATED AIR, NEUTRAL GASES AND LIQUIDS
DIRECT OPERATED

BRASS

PIPE MOUNTING

NORMALLY CLOSED

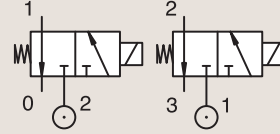

Port size	Orifice Ø		Flow factors			Operating Pressure Differential			Fluid Temp.		Seat Seal	Parker LUCIFER® Valves			IS	Power		Coil Group	Dwg. No.	
	1	(2)	1	(2)	1	(2)	Min	Max (MOPD)	Min	Max		Valve Ref.	Housing Ref.	Coil Ref.		AC W	DC W			
BSP	mm		Kv		KV		bar	AC bar	DC bar	°C	°C									
1/4"	1.2	1.5	0.8	1.5	0.05	0.09	0	30	-	-30	130	Ruby	E131K64	4270	481000		8	-	2.0	3510
	1.2	1.5	0.8	1.5	0.05	0.09	0	30	30	-30	140	Ruby	E131K64	4270	486265		14	14	2.0	3510
	1.2	1.5	0.8	1.5	0.05	0.09	0	30	-	-30	130	Ruby	E131K6450 ₁	4270	481000		8	-	2.0	3510
	1.2	1.5	0.8	1.5	0.05	0.09	0	30	30	-30	140	Ruby	E131K6450 ₁	4270	486265		14	14	2.0	3510
	1.5	1.5	1.5	1.5	0.09	0.09	0	-	7	-20	75	PUR	131K0497	2995	482740		-	1.6	6.0/8.0	8023
	1.5	1.5	1.5	1.5	0.09	0.09	0	7	7	-20	75	PUR	131K0497	-	495900		2.5	2	6.0/8.0	8023
	1.5	1.5	1.5	1.5	0.09	0.09	0	-	7	-20	75	PUR	131K0497	-	495910	*	-	0.3 to 3	6.0/8.0	8023
	1.5	1.5	1.5	1.5	0.09	0.09	0	-	7	-20	75	PUR	131K0497	2995	496125		-	1.6	6.0/8.0	8023
	1.5	1.5	1.5	1.5	0.09	0.09	0	16	16	-10	120	FKM	E131K04	4270	481000		8	8	2.0	3510
	1.5	1.5	1.5	1.5	0.09	0.09	0	16	16	-10	100	FKM	E131K04	2995	481865		8	9	2.0	3510
	1.5	1.5	1.5	1.5	0.09	0.09	0	16	16	-10	120	FKM	E131K04	4270	486265		14	14	2.0	3510
	1.5	1.5	1.5	1.5	0.09	0.09	0	15	15	-10	120	FKM	E131K0450 ₁	4270	481000		8	8	2.1	3510
	1.5	1.5	1.5	1.5	0.09	0.09	0	15	15	-10	100	FKM	E131K0450 ₁	2995	481865		8	9	2.1	3510
	2	3	2.5	4.5	0.15	0.27	0	10	10	-10	75	FKM	131T23	4270	481000		8	8	2.0	3223
	2	3	2.5	4.5	0.15	0.27	0	10	10	-10	75	FKM	131T23	2995	481865		8	9	2.0	3223
	2	3	2.5	4.5	0.15	0.27	0	10	10	-10	75	FKM	131T23	4270	486265		14	14	2.0	3223
2	3	2.5	4.5	0.15	0.27	0	10	10	-10	75	FKM	131T2301 ₁	4270	481000		8	8	2.0	3223	
2	3	2.5	4.5	0.15	0.27	0	10	10	-10	75	FKM	131T2301 ₁	2995	481865		8	9	2.0	3223	
2	3	2.5	4.5	0.15	0.27	0	10	10	-10	75	FKM	131T2301 ₁	4270	486265		14	14	2.0	3223	

Notes:

1. With manual override



For this page	Port size	Orifice (mm)	Kv (l/min)	MOPD (bar)	Fluid Temp (°C)	Amb Temp (°C)
From	1/4"	1.2	0.8	7	-30	-20
To	1/4"	2	2.5	30	140	50

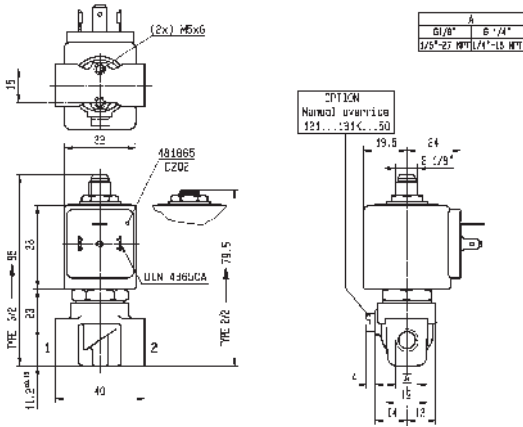

Drawing 3510

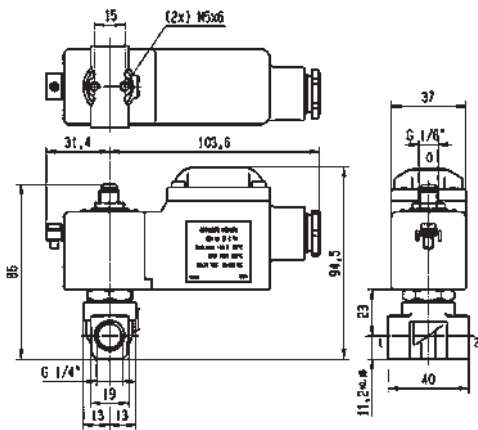

Drawing 8023

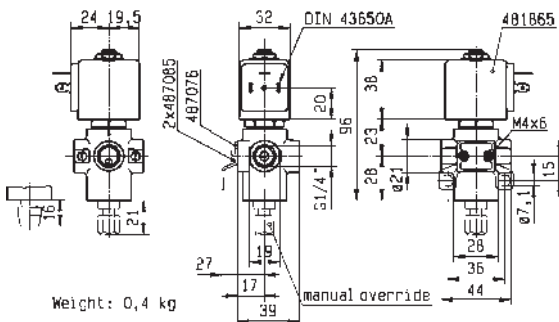

Drawing 3223

3/2

VALVES FOR DRY OR LUBRICATED AIR, NEUTRAL GASES AND LIQUIDS
DIRECT OPERATED

BRASS
PIPE MOUNTING

NORMALLY CLOSED

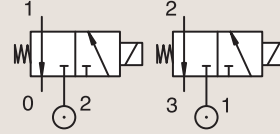

Port size	Orifice Ø		Flow factors			Operating Pressure Differential			Fluid Temp.		Seat Seal	Parker LUCIFER® Valves			Power		Coil Group	Dwg. No.	
	1	(2)	1	(2)	1	(2)	Min	Max (MOPD)	Min	Max		Valve Ref.	Housing Ref.	Coil Ref.	AC W	DC W			
BSP	mm		Kv l/min		KV l/min		bar	AC bar	DC bar	°C	°C								
1/4"	2	2.5	2.5	3.5	0.15	0.21	0	10	10	-10	120	FKM	E131K06	4270	481000	8	8	2.0	8119
	2	2.5	2.5	3.5	0.15	0.21	0	10	10	-10	100	FKM	E131K06	2995	481865	8	9	2.0	8119
	2	2.5	2.5	3.5	0.15	0.21	0	10	10	-10	120	FKM	E131K06	4270	486265	14	14	2.0	8119
	2	2.5	2.5	3.5	0.15	0.21	0	10	10	-10	120	FKM	E131K0650 ₁	4270	481000	8	8	2.1	3510
	2	2.5	2.5	3.5	0.15	0.21	0	10	10	-10	100	FKM	E131K0650 ₁	2995	481865	8	9	2.1	3510
	2.5	2.5	3	3	0.18	0.18	0	-	2	-20	75	PUR	131K0397	2995	496125	-	1.6	6.0/8.0	8023
	2.5	3.5	3.5	5.5	0.21	0.33	0	7	7	-10	75	FKM	131T29	4270	481000	8	8	2.1	3223
	2.5	3.5	3.5	5.5	0.21	0.33	0	7	7	-10	75	FKM	131T29	2995	481865	8	9	2.1	3223
	2.5	3.5	3.5	5.5	0.21	0.33	0	7	7	-10	75	FKM	131T2901 ₁	4270	481000	8	8	2.1	3223
	2.5	3.5	3.5	5.5	0.21	0.33	0	7	7	-10	75	FKM	131T2901 ₁	2995	481865	8	9	2.1	3223

Notes:

1. With manual override

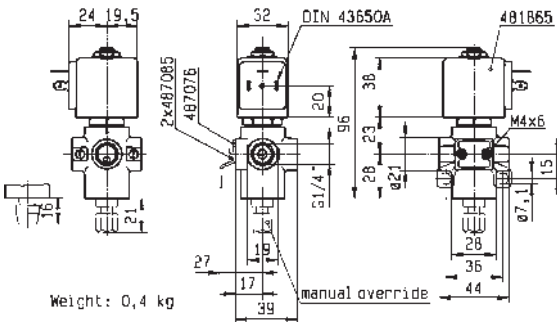

Drawing 3223



For this page	Port size	Orifice (mm)	Kv (l/min)	MOPD (bar)	Fluid Temp (°C)	Amb Temp (°C)
From	1/4"	2	2.5	2	-20	-20
To	1/4"	2.5	3.5	10	120	50

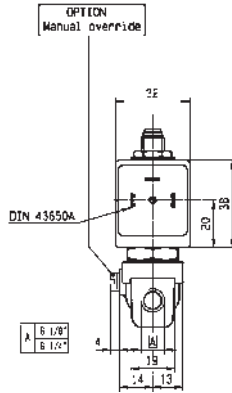
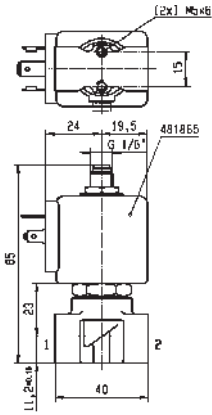

Drawing 8119

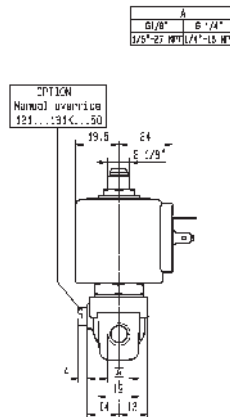
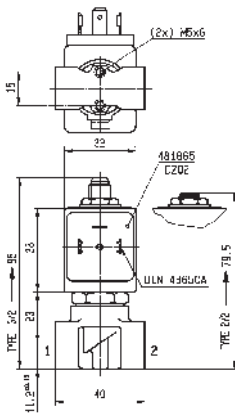

Drawing 3510

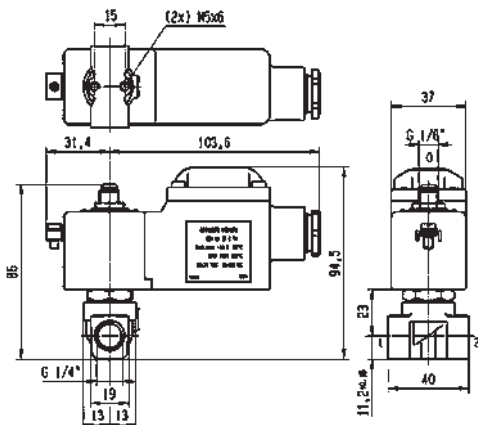

Drawing 8023

3/2

VALVES FOR DRY OR LUBRICATED AIR, NEUTRAL GASES AND LIQUIDS
DIRECT OPERATED

BRASS

PIPE MOUNTING

NORMALLY CLOSED

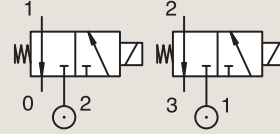

Port size	Orifice Ø		Flow factors			Operating Pressure Differential			Fluid Temp.		Seat Seal	Parker LUCIFER® Valves			Power		Coil Group	Dwg. No.	
	1	(2)	1	(2)	1	(2)	Min	Max (MOPD)	Min	Max		Valve Ref.	Housing Ref.	Coil Ref.	AC W	DC W			
BSP	mm		Kv l/min		KV l/min		bar	AC bar	DC bar	°C	°C								
1/4"	2.5	6	2.7	15	0.16	0.9	0.1	7	7	-10	75	FKM	E131E03	4270	481000	8	8	2.0	3525
	2.5	6	2.7	15	0.16	0.9	0.1	7	7	-10	75	FKM	E131E03	2995	481865	8	9	2.0	3525
	2.5	6	2.7	15	0.16	0.9	0.1	7	7	-10	75	FKM	E131E03	4270	486265	14	14	2.0	3525
	2.5	2.5	3.5	3.5	0.21	0.21	0	7	7	-10	100	FKM	E131K03	4270	481000	8	8	2.0	3510
	2.5	2.5	3.5	3.5	0.21	0.21	0	7	7	-10	100	FKM	E131K03	2995	481865	8	9	2.0	3510
	2.5	2.5	3.5	3.5	0.21	0.21	0	7	7	-40	75	PUR	E131K0308	4270	481000	8	8	2.1	3510
	2.5	2.5	3.5	3.5	0.21	0.21	0	7	7	-40	75	PUR	E131K0308	2995	481865	8	9	2.1	3510
	2.5	2.5	3.5	3.5	0.21	0.21	0	7	7	-10	120	FKM	E131K0350 ₁	4270	481000	8	8	2.1	3510
	2.5	2.5	3.5	3.5	0.21	0.21	0	7	7	-10	100	FKM	E131K0350 ₁	2995	481865	8	9	2.1	3510
	2.5	2.5	3.5	3.5	0.21	0.21	0	7	7	-30	130	Ruby	E131K63	4270	481000	8	8	2.0	3510
	2.5	2.5	3.5	3.5	0.21	0.21	0	7	7	-30	100	Ruby	E131K63	2995	481865	8	9	2.0	3510
	2.5	2.5	3.5	3.5	0.21	0.21	0	7	7	-30	130	Ruby	E131K6350 ₁	4270	481000	8	8	2.1	3510
	2.5	2.5	3.5	3.5	0.21	0.21	0	7	7	-30	100	Ruby	E131K6350 ₁	2995	481865	8	9	2.1	3510
	3	4	4.5	6	0.27	0.36	0	10	-	-10	75	FKM	131T22	4270	481044	14	-	2.2	3223
	3	4	4.5	6	0.27	0.36	0	10	-	-10	75	FKM	131T22	2995	492425	14	-	2.2	3223
	4.5	6	7	9	0.42	0.54	0	2	2	-10	75	FKM	131T21	4270	481000	8	8	2.0	3223
4.5	6	7	9	0.42	0.54	0	2	2	-10	75	FKM	131T21	2995	481865	8	9	2.0	3223	
4.5	6	7	9	0.42	0.54	0	2	2	-10	75	FKM	131T21	4270	486265	14	14	2.0	3223	

Notes:

1. With manual override

3 WAY VALVES



For this page	Port size	Orifice (mm)	Kv (l/min)	MOPD (bar)	Fluid Temp (°C)	Amb Temp (°C)
From	1/4"	2.5	2.7	2	-40	-40
To	1/4"	4.5	7	10	130	50

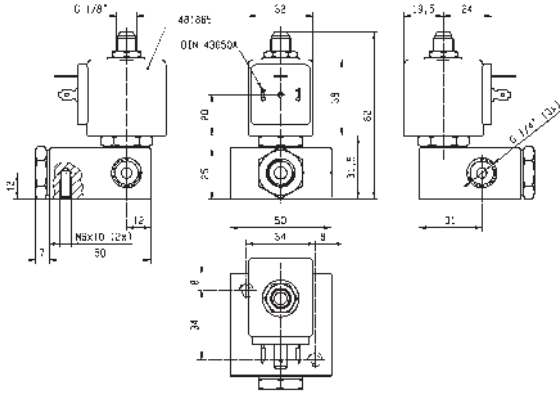

Drawing 3525

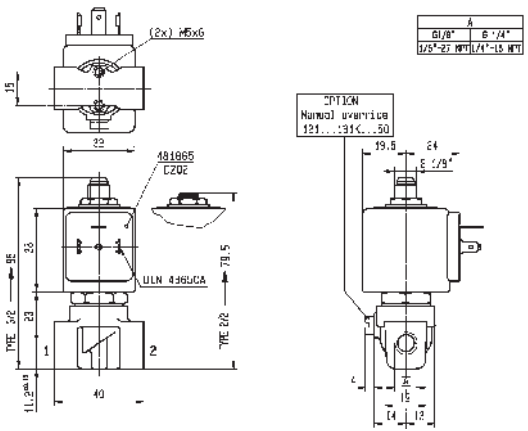

Drawing 3510

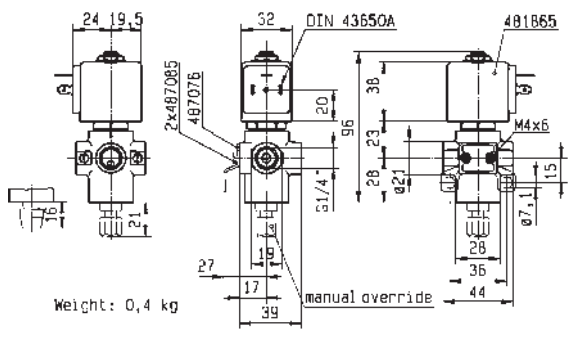

Drawing 3223



3/2

VALVES FOR DRY OR LUBRICATED AIR, NEUTRAL GASES AND LIQUIDS
DIRECT OPERATED

BRASS

PIPE MOUNTING

NORMALLY OPEN

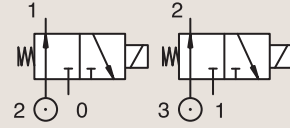

Port size	Orifice Ø		Flow factors				Operating Pressure Differential			Fluid Temp.		Seat Seal	Parker LUCIFER® Valves			Power		Coil Group	Dwg. No.
	1	(2)	1	(2)	1	(2)	Min	Max (MOPD)	Min	Max	Valve Ref.		Housing Ref.	Coil Ref.	AC W	DC W			
BSP	mm		Kv l/min		KV l/min		bar	AC bar	DC bar	°C	°C								
1/4"	1.5	1.5	1.4	1.4	0.08	0.08	0	16	16	-10	120	FKM	132K04	4270	481000	8	8	2.1	3510
	1.5	1.5	1.4	1.4	0.08	0.08	0	16	16	-10	100	FKM	132K04	2995	481865	8	9	2.1	3510
	2	2	1.8	1.8	0.10	0.10	0	10	10	-10	120	FKM	132K06	4270	481000	8	8	2.1	3510
	2	2	1.8	1.8	0.10	0.10	0	10	10	-10	100	FKM	132K06	2995	481865	8	9	2.1	3510
	2	3	2.5	4.5	0.15	0.27	0	10	5	-10	75	FKM	132T23	4270	481000	8	8	2.0	3223
	2	3	2.5	4.5	0.15	0.27	0	10	5	-10	75	FKM	132T23	2995	481865	8	9	2.0	3223
	2	3	2.5	4.5	0.15	0.27	0	-	10	-10	75	FKM	132T23	4270	486265	-	14	2.0	3223
	2	3	2.5	4.5	0.15	0.27	0	10	5	-10	75	FKM	132T2301 ₁	4270	481000	8	8	2.0	3223
	2	3	2.5	4.5	0.15	0.27	0	10	5	-10	75	FKM	132T2301 ₁	2995	481865	8	9	2.0	3223
	2	3	2.5	4.5	0.15	0.27	0	-	10	-10	75	FKM	132T2301 ₁	4270	486265	-	14	2.0	3223
	2.5	2.5	2.2	2.2	0.13	0.13	0	7	7	-10	120	FKM	132K03	4270	481000	8	8	2.1	3510
	2.5	2.5	2.2	2.2	0.13	0.13	0	7	7	-10	100	FKM	132K03	2995	481865	8	9	2.1	3510
	3	4	4.5	6	0.27	0.36	0	10	-	-10	75	FKM	132T22	4270	481044	14	-	2.2	3223
	3	4	4.5	6	0.27	0.36	0	7	-	-10	75	FKM	132T22	2995	492425	14	-	2.2	3223

Notes:

1. With manual override



For this page	Port size	Orifice (mm)	Kv (l/min)	MOPD (bar)	Fluid Temp (°C)	Amb Temp (°C)
From	1/4"	1.5	1.4	5	-10	-30
To	1/4"	3	4.5	16	120	50

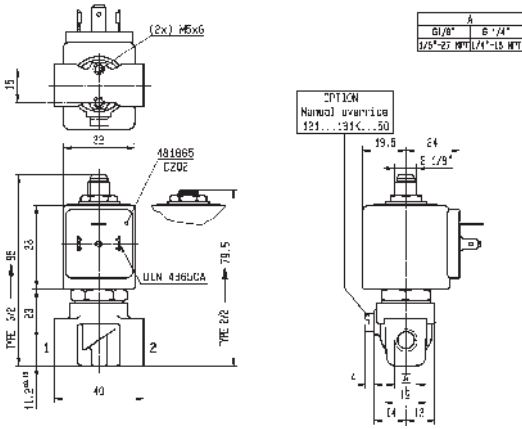

Drawing 3510

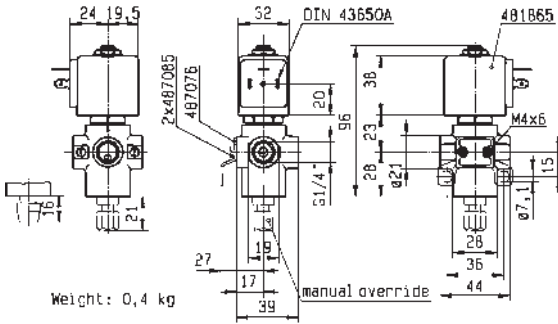

Drawing 3223

3/2

VALVES FOR DRY OR LUBRICATED AIR, NEUTRAL GASES AND LIQUIDS
DIRECT OPERATED

BRASS

PIPE MOUNTING

UNIVERSAL

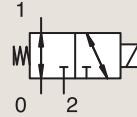

Port size	Orifice Ø		Flow factors				Operating Pressure Differential			Fluid Temp.		Seat Seal	Parker Valves			Power		Coil Group	Dwg. No.
	1	(2)	1	(2)	1	(2)	Min	Max(MOPD)	Min	Max	Valve Order Number		Valve Type	Coil Type	AC W	DC W			
BSP	mm		Kv l/min		KV l/min		bar	AC bar	DC bar	°C	°C								
1/8"	1.5	1.5	1.2	-	0.07	-	0	10	-	-10	140	FKM	362410J	PM139AV	ZB09	9	-	20.1/20.2	022
	1.5	1.5	1.2	-	0.07	-	0	-	10	-10	140	FKM	362410J	PM139AV	ZB12	-	12	20.1/20.2	022
1/4"	2	2	2	-	0.12	-	0	7	-	-10	140	FKM	362460J	PM139FV	ZB09	9	-	20.1/20.2	022
	2	2	2	-	0.12	-	0	-	7	-10	140	FKM	362460J	PM139FV	ZB12	-	12	20.1/20.2	022
	2.5	2.5	2.8	-	0.17	-	0	4	-	-10	140	FKM	362470J	PM139GV	ZB09	9	-	20.1/20.2	022
	2.5	2.5	2.8	-	0.17	-	0	-	4	-10	140	FKM	362470J	PM139GV	ZB12	-	12	20.1/20.2	022
	3.5	2.5	5	-	0.3	-	0	1	-	-10	140	FKM	362475J	PM139LV	ZB09	9	-	20.1/20.2	022
	3.5	2.5	5	-	0.3	-	0	-	1	-10	140	FKM	362475J	PM139LV	ZB12	-	12	20.1/20.2	022



For this page	Port size	Orifice (mm)	Kv (l/min)	MOPD (bar)	Fluid Temp (°C)	Amb Temp (°C)
From	1/8"	1.5	1.2	1	-10	-10
To	1/4"	3.5	5	10	140	50

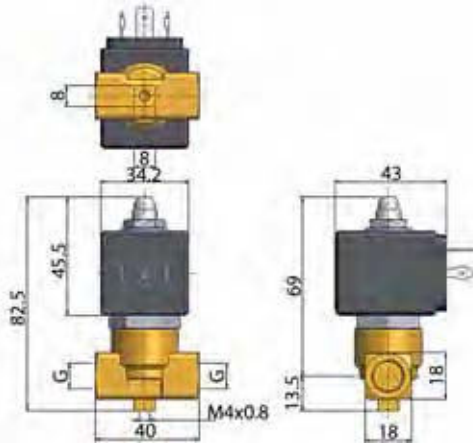

Drawing 022

3/2

VALVES FOR DRY OR LUBRICATED AIR, NEUTRAL GASES AND LIQUIDS
DIRECT OPERATED

BRASS

PIPE MOUNTING

UNIVERSAL

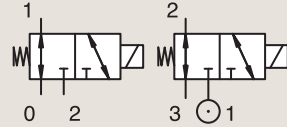

Port size	Orifice Ø		Flow factors				Operating Pressure Differential			Fluid Temp.		Seat Seal	Parker LUCIFER® Valves			IS	Power		Coil Group	Dwg. No.
	1	(2)	1	(2)	1	(2)	Min	Max (MOPD)	Min	Max	Valve Ref.		Housing Ref.	Coil Ref.	AC W		DC W			
BSP	mm		Kv		KV		bar	AC bar	DC bar	°C	°C									
1/8"	1.5	1.5	1.5	1.5	0.09	0.09	0	10	10	-10	100	FKM	E133K14	2995	481865	8	9	2.1	3510	
	1.5	1.5	1.5	1.5	0.09	0.09	0	10	10	-10	120	FKM	E133K14	4270	481000	8	8	2.1	3510	
	2	2	2.5	2.5	0.15	0.15	0	7	7	-10	100	FKM	E133K16	2995	481865	8	9	2.1	3510	
	2	2	2.5	2.5	0.15	0.15	0	7	7	-10	120	FKM	E133K16	4270	481000	8	8	2.1	3510	
	2.5	2.5	3.5	3.5	0.21	0.21	0	4	4	-10	100	FKM	E133K13	2995	481865	8	9	2.1	3510	
	2.5	2.5	3.5	3.5	0.21	0.21	0	4	4	-10	120	FKM	E133K13	4270	481000	8	8	2.1	3510	
1/4"	0.8	0.8	0.3	0.3	0.02	0.02	0	30	30	-10	100	FKM	E133K05	2995	481865	8	9	2.1	3510	
	0.8	0.8	0.3	0.3	0.02	0.02	0	30	30	-10	120	FKM	E133K05	4270	481000	8	8	2.1	3510	
	0.8	0.8	0.3	0.3	0.02	0.02	0	30	30	-10	120	FKM	E133K05	4270	486265	14	14	2.0	3510	
	1.5	1.5	1.5	1.5	0.09	0.09	0	-	3	-20	75	PUR	133K0497	2995	482740	-	1.6	6.0/8.0	8023	
	1.5	1.5	1.5	1.5	0.09	0.09	0	3	3	-20	75	PUR	133K0497	-	495900	2.5	2	6.0/8.0	8023	
	1.5	1.5	1.5	1.5	0.09	0.09	0	-	3	-20	75	PUR	133K0497	-	495910	*	-	0.3 to 3	6.0/8.0	8023
	1.5	1.5	1.5	1.5	0.09	0.09	0	-	3	-20	75	PUR	133K0497	2995	496125	-	1.6	6.0/8.0	8023	
	1.5	1.5	1.5	1.5	0.09	0.09	0	10	10	-10	100	FKM	E133K04	2995	481865	8	9	2.0	3510	
	1.5	1.5	1.5	1.5	0.09	0.09	0	10	10	-10	120	FKM	E133K04	4270	481000	8	8	2.0	3510	
	1.5	1.5	1.5	1.5	0.09	0.09	0	10	10	-10	120	FKM	E133K04	4270	486265	14	14	2.0	3510	
	1.5	1.5	1.5	1.5	0.09	0.09	0	10	10	-10	100	FKM	E133K0450 ₁	2995	481865	8	9	2.1	3510	
	1.5	1.5	1.5	1.5	0.09	0.09	0	10	10	-10	120	FKM	E133K0450 ₁	4270	481000	8	8	2.1	3510	
	2	2	2.5	2.5	0.15	0.15	0	7	7	-10	75	FKM	133T23	2995	481865	8	9	2.1	3223	
	2	2	2.5	2.5	0.15	0.15	0	7	7	-10	75	FKM	133T23	4270	481000	8	8	2.1	3223	
	2	2	2.5	2.5	0.15	0.15	0	7	7	-10	75	FKM	133T2301 ₁	2995	481865	8	9	2.1	3223	
	2	2	2.5	2.5	0.15	0.15	0	7	7	-10	75	FKM	133T2301 ₁	4270	481000	8	8	2.1	3223	
	2	2	2.5	2.5	0.15	0.15	0	7	7	-10	100	FKM	E133K06	2995	481865	8	9	2.0/3.0	3510	
	2	2	2.5	2.5	0.15	0.15	0	7	7	-10	120	FKM	E133K06	4270	481000	8	8	2.0/3.0	3510	
	2	2	2.5	2.5	0.15	0.15	0	7	7	-10	120	FKM	E133K06	4270	486265	14	14	2.0/3.0	3510	
	2	2	2.5	2.5	0.15	0.15	0	7	7	-10	100	FKM	E133K0650 ₁	2995	481865	8	9	2.1	3510	
	2	2	2.5	2.5	0.15	0.15	0	7	7	-10	120	FKM	E133K0650 ₁	4270	481000	8	8	2.1	3510	
	2.5	2.5	3.5	3.5	0.21	0.21	0	4	4	-10	100	FKM	E133K03	2995	481865	8	9	2.0	3510	
	2.5	2.5	3.5	3.5	0.21	0.21	0	4	4	-10	120	FKM	E133K03	4270	481000	8	8	2.0	3510	
	2.5	2.5	3.5	3.5	0.21	0.21	0	4	4	-10	120	FKM	E133K03	4270	486265	14	14	2.0	3510	
	2.5	2.5	3.5	3.5	0.21	0.21	0	4	4	-10	100	FKM	E133K0350 ₁	2995	481865	8	9	2.1	3510	
	2.5	2.5	3.5	3.5	0.21	0.21	0	4	4	-10	120	FKM	E133K0350 ₁	4270	481000	8	8	2.1	3510	
	3	3	4.5	4.5	0.27	0.27	0	2	2	-10	75	FKM	133T21	2995	481865	8	9	2.1	3223	
	3	3	4.5	4.5	0.27	0.27	0	2	2	-10	75	FKM	133T21	4270	481000	8	8	2.1	3223	

Notes:

1. With manual override



3 WAY VALVES



For this page	Port size	Orifice (mm)	Kv (l/min)	MOPD (bar)	Fluid Temp (°C)	Amb Temp (°C)
From	1/8"	0.8	0.3	2	-20	-20
To	1/4"	3	4.5	30	120	50

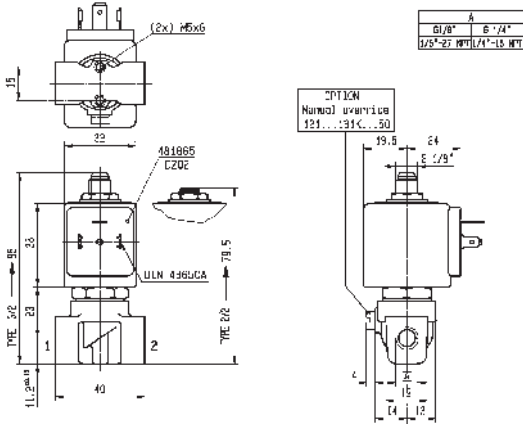

Drawing 3510

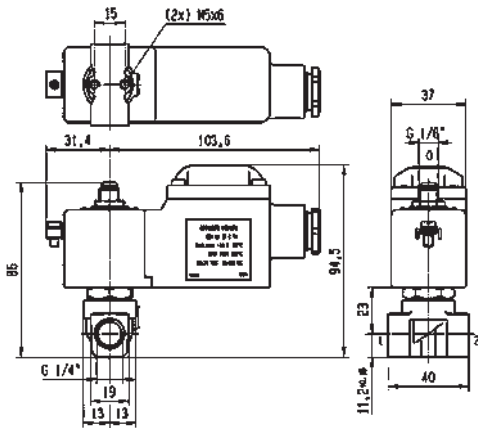

Drawing 8023

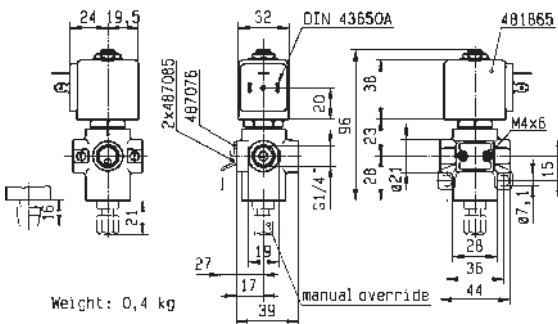

Drawing 3223

3/2

VALVES FOR DRY OR LUBRICATED AIR, NEUTRAL GASES AND LIQUIDS
DIRECT OPERATED

BRASS

PIPE MOUNTING

UNIVERSAL

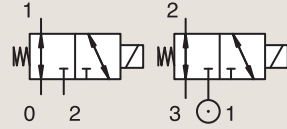

Port size	Orifice Ø		Flow factors			Operating Pressure Differential			Fluid Temp.		Seat Seal	Parker LUCIFER® Valves			Power		Coil Group	Dwg. No.	
	1	(2)	1	(2)	1	(2)	Min	Max (MOPD)	Min	Max		Valve Ref.	Housing Ref.	Coil Ref.	AC W	DC W			
BSP	mm		Kv	I/min	KV	m³/h	bar	AC bar	DC bar	°C	°C								
1/4"	3	3	4.5	4.5	0.27	0.27	0	2	2	-10	75	FKM	133T2101 ₁	2995	481865	8	9	2.1	3223
	3	3	4.5	4.5	0.27	0.27	0	2	2	-10	75	FKM	133T2101 ₁	4270	481000	8	8	2.1	3223

Notes:

1. With manual override

BRASS

PIPE MOUNTING

CONTROL BY ELECTRIC IMPULSE

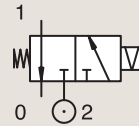

Port size	Orifice Ø		Flow factors			Operating Pressure Differential			Fluid Temp.		Seat Seal	Parker LUCIFER® Valves			Power		Coil Group	Dwg. No.	
	1	(2)	1	(2)	1	(2)	Min	Max (MOPD)	Min	Max		Valve Ref.	Housing Ref.	Coil Ref.	AC W	DC W			
BSP	mm		Kv	I/min	KV	I/min	bar	AC bar	DC bar	°C	°C								
1/4"	1.5	1.5	1.5	1.5	0.09	0.09	0	-	16	-10	100	FKM	135K04	4269	485400	-	13	4.0	8104



For this page	Port size	Orifice (mm)	Kv (l/min)	MOPD (bar)	Fluid Temp (°C)	Amb Temp (°C)
From	1/4"	1.5	1.5	2	-10	-10
To	1/4"	3	4.5	16	100	50

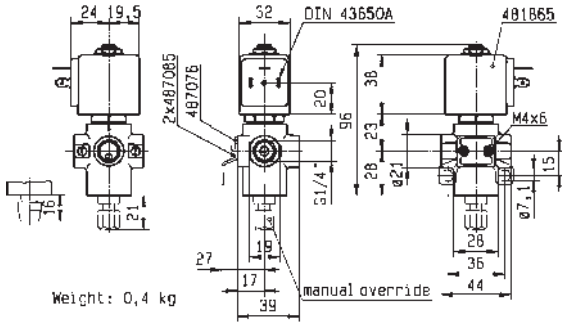

Drawing 3223

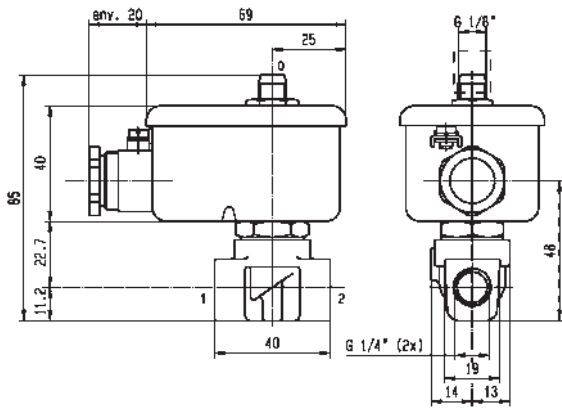

Drawing 8104

3/2

VALVES FOR DRY OR LUBRICATED AIR, NEUTRAL GASES AND LIQUIDS
DIRECT OPERATED

BRASS

SUB-BASE MOUNTING

NORMALLY CLOSED

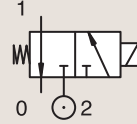

Port size	Orifice Ø		Flow factors				Operating Pressure Differential			Fluid Temp.		Seat Seal	Parker Valves			Power		Coil Group	Dwg. No.
	1	(2)	1	(2)	1	(2)	Min	Max(MOPD)		Min	Max		Valve Order Number	Valve Type	Coil Type	AC W	DC W		
								mm	Kv l/min										
SB	1.3	2.5	1	-	0.06	-	0	20	10	-30	140	Ruby	360490J ₁	PM128GR	ZB09	9	-	20.1/20.2	009
	1.3	2.5	1	-	0.06	-	0	20	10	-30	140	Ruby	360480J ₁	PM128IR	YB09	9	-	20.1/20.2	010
	1.3	2.5	1	-	0.06	-	0	20	10	-30	140	Ruby	360480J ₁	PM128IR	ZB09	9	-	20.1/20.2	010
	1.3	2.5	1	-	0.06	-	0	20	10	-10	140	FKM	360506 ₁	PM128ISV	ZB09	9	-	20.1/20.2	010
	1.3	2.5	1	-	0.06	-	0	20	10	-10	140	FKM	360479J ₁	PM128IV	ZB09	9	-	20.1/20.2	010

Notes:

1. Maximum static pressure: 14.5 Bar (for Viton sealing, maximum static pressure: 12 Bar)



For this page	Port size	Orifice (mm)	Kv (l/min)	MOPD (bar)	Fluid Temp (°C)	Amb Temp (°C)
From	SB	1.3	1	10	-30	-10
To	SB	1.3	1	20	140	50

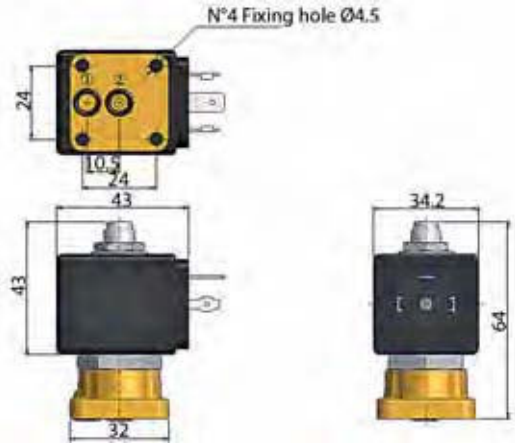

Drawing 009

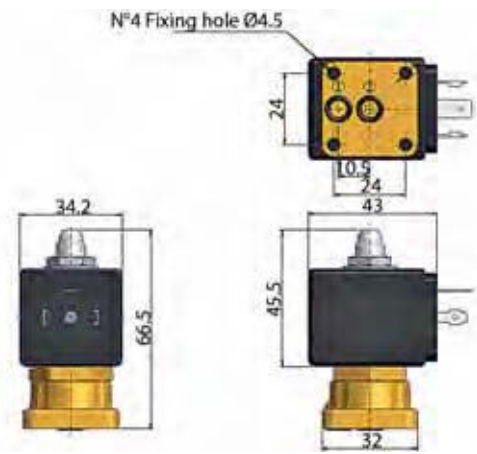

Drawing 010

3/2

VALVES FOR DRY OR LUBRICATED AIR, NEUTRAL GASES AND LIQUIDS
DIRECT OPERATED

BRASS
SUB-BASE MOUNTING

NORMALLY CLOSED

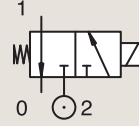

Port size	Orifice Ø		Flow factors			Operating Pressure Differential			Fluid Temp.		Seat Seal	Parker LUCIFER® Valves			IS	Power		Coil Group	Dwg. No.	
	1	(2)	1	(2)	1	(2)	Min	Max (MOPD)	Min	Max		Valve Ref.	Housing Ref.	Coil Ref.		AC W	DC W			
	mm		Kv l/min		KV l/min		bar	AC bar	DC bar	°C										°C
SB	1.2	1.5	0.7	0.9	0.04	0.05	0	10	10	-10	75	FKM	131M75	8993	488980		2	2.5	1.1	3383
	1.2	1.5	0.7	0.9	0.04	0.05	0	10	10	-10	75	FKM	131M7550	8993	488980		2	2.5	1.1	3383
	1.5	1.5	0.9	0.9	0.05	0.05	0	7	7	-10	75	FKM	131M74	8993	488980		2	2.5	1.1	3383
	1.5	1.5	0.9	0.9	0.05	0.05	0	7	7	-10	75	FKM	131M7450	8993	488980		2	2.5	1.1	3383
	1	1	0.6	0.6	0.03	0.03	0	-	10	-10	75	FKM	131F4490	2995	483580.01	*	-	0.5 to 3	7.0/8.0	7057
	1	1	0.6	0.6	0.03	0.03	0	-	10	-10	75	FKM	131F4490	-	488660.01	*	-	0.3 to 3	7.0/8.0	7057
	1	1	0.6	0.6	0.03	0.03	0	-	10	-10	75	FKM	131F4490	-	495910	*	-	0.3 to 3	7.0/8.0	7057
	1.5	2	1.5	2.2	0.09	0.13	0	-	16	-10	100	FKM	131F4410	2995	481865		-	9	2.1	3509
	1.5	1.5	1.5	1.5	0.09	0.09	0	-	7	-20	75	PUR	131F4497	2995	482740		-	1.6	6.0/8.0	8022
	1.5	1.5	1.5	1.5	0.09	0.09	0	7	7	-20	75	PUR	131F4497	-	495900		2.5	2	6.0/8.0	8022
	1.5	1.5	1.5	1.5	0.09	0.09	0	-	7	-20	75	PUR	131F4497	-	495910	*	-	0.3 to 3	6.0/8.0	8022
	1.5	1.5	1.5	1.5	0.09	0.09	0	-	7	-20	75	PUR	131F4497	2995	496125		-	1.6	6.0/8.0	8022

Notes:

1. With manual override

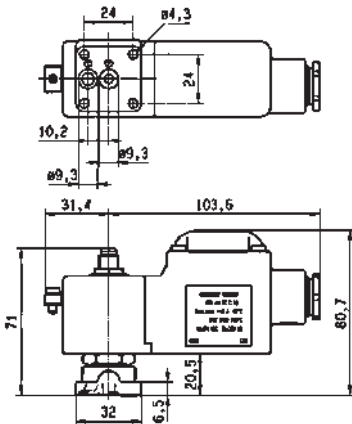

Drawing 8022



For this page	Port size	Orifice (mm)	Kv (l/min)	MOPD (bar)	Fluid Temp (°C)	Amb Temp (°C)
From	SB	1	0.6	7	-20	-20
To	SB	1.5	1.5	16	100	50

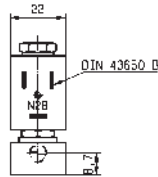
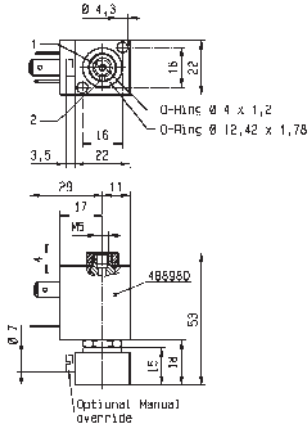

Drawing 3383

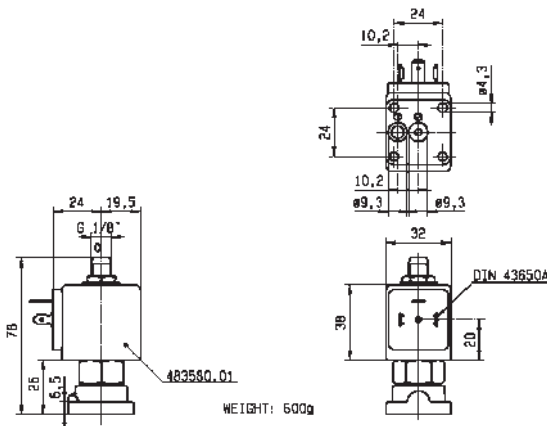

Drawing 7057

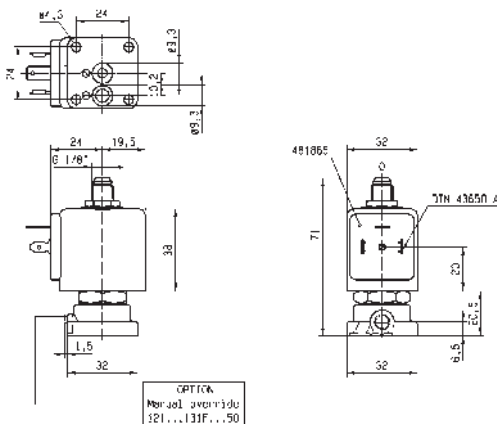

Drawing 3509

3/2

VALVES FOR DRY OR LUBRICATED AIR, NEUTRAL GASES AND LIQUIDS
DIRECT OPERATED

BRASS

SUB-BASE MOUNTING

NORMALLY CLOSED

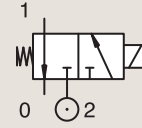

Port size	Orifice Ø		Flow factors			Operating Pressure Differential			Fluid Temp.		Seat Seal	Parker LUCIFER® Valves			Power		Coil Group	Dwg. No.	
	1	(2)	1	(2)	1	(2)	Min	Max (MOPD)		Min		Max	Valve Ref.	Housing Ref.	Coil Ref.	AC W			DC W
	mm		Kv l/min		KV m³/h		bar	AC bar	DC bar	°C		°C							
SB	1.5	1.5	1.5	1.5	0.09	0.09	0	15	15	-10	100	FKM	E131F44	2995	481865	8	9	2.1	3509
	1.5	1.5	1.5	1.5	0.09	0.09	0	15	15	-10	120	FKM	E131F44	4270	481000	8	8	2.1	3509
	1.5	1.5	1.5	1.5	0.09	0.09	0	15	15	-10	100	FKM	E131F4450 ₁	2995	481865	8	9	2.1	3509
	1.5	1.5	1.5	1.5	0.09	0.09	0	15	15	-10	100	FKM	E131F4450 ₁	4270	481000	8	8	2.1	3509
	2	2.5	2.5	3.5	0.15	0.21	0	10	10	-10	100	FKM	131F46	2995	481865	8	9	2.1	3509
	2	2.5	2.5	3.5	0.15	0.21	0	10	10	-10	120	FKM	131F46	4270	481000	8	8	2.1	3509
	2	2.5	2.5	3.5	0.15	0.21	0	10	10	-10	100	FKM	131F4650 ₁	2995	481865	8	9	2.1	3509
	2	2.5	2.5	3.5	0.15	0.21	0	10	10	-10	120	FKM	131F4650 ₁	4270	481000	8	8	2.1	3509
	2.5	2.5	3.5	3.5	0.21	0.21	0	7	7	-10	100	FKM	E131F43	2995	481865	8	9	2.1	3509
	2.5	2.5	3.5	3.5	0.21	0.21	0	7	7	-10	120	FKM	E131F43	4270	481000	8	8	2.1	3509
	2.5	2.5	3.5	3.5	0.21	0.21	0	7	7	-10	100	FKM	E131F4350 ₁	2995	481865	8	9	2.0	3509
	2.5	2.5	3.5	3.5	0.21	0.21	0	7	7	-10	120	FKM	E131F4350 ₁	4270	481000	8	8	2.0	3509
2.5	2.5	3.5	3.5	0.21	0.21	0	7	7	-10	100	FKM	E131F4350 ₁	4270	486265	14	14	2.0	3509	

Notes:

1. With manual override

BRASS

SUB-BASE MOUNTING

NORMALLY OPEN

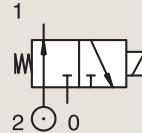

Port size	Orifice Ø		Flow factors			Operating Pressure Differential			Fluid Temp.		Seat Seal	Parker LUCIFER® Valves			Power		Coil Group	Dwg. No.	
	1	(2)	1	(2)	1	(2)	Min	Max (MOPD)		Min		Max	Valve Ref.	Housing Ref.	Coil Ref.	AC W			DC W
	mm		Kv l/min		KV m³/h		bar	AC bar	DC bar	°C		°C							
SB	1.5	1.5	1.4	1.4	0.084	0.084	0	15	15	-10	75	FKM	132F44	4270	481000	8	8	2.1	3509
	1.5	1.5	1.4	1.4	0.084	0.084	0	15	15	-10	75	FKM	132F44	2995	481865	8	9	2.1	3509
	2	2	1.8	1.8	0.108	0.108	0	10	10	-10	120	FKM	132F46	4270	481000	8	8	2.1	3509
	2	2	1.8	1.8	0.108	0.108	0	10	10	-10	100	FKM	132F46	2995	481865	8	9	2.1	3509
	2.5	2.5	2.2	2.2	0.132	0.132	0	7	7	-10	75	FKM	132F43	4270	481000	8	8	2.0	3509
	2.5	2.5	2.2	2.2	0.132	0.132	0	7	7	-10	75	FKM	132F43	2995	481865	8	9	2.0	3509
	2.5	2.5	2.2	2.2	0.132	0.132	0	7	7	-10	75	FKM	132F43	4270	486265	14	14	2.0	3509



For this page	Port size	Orifice (mm)	Kv (l/min)	MOPD (bar)	Fluid Temp (°C)	Amb Temp (°C)
From	SB	1.5	1.4	7	-10	-30
To	SB	2.5	3.5	15	120	50

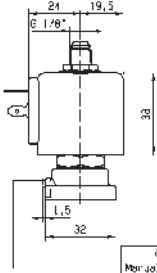
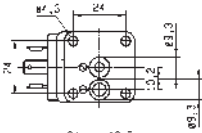

OPTICA
Materia: acciaio
321...131F...50

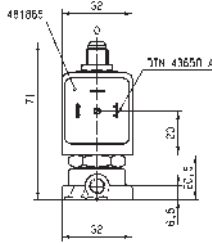

Drawing 3509

3/2

VALVES FOR DRY OR LUBRICATED AIR, NEUTRAL GASES AND LIQUIDS
DIRECT OPERATED

BRASS
SUB-BASE MOUNTING

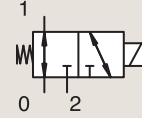

UNIVERSAL

Port size	Orifice Ø		Flow factors				Operating Pressure Differential			Fluid Temp.		Seat Seal	Parker LUCIFER® Valves			Power		Coil Group	Dwg. No.
	1	(2)	1	(2)	1	(2)	Min	Max (MOPD)		Min	Max		Valve Ref.	Housing Ref.	Coil Ref.	AC W	DC W		
	mm		Kv l/min		KV l/min		bar	AC bar	DC bar	°C	°C								
SB	1.5	1.5	1.5	1.5	0.09	0.09	0	10	10	-10	100	FKM	E133F4450 ₁	4270	481000	8	8	2.1	3509
	1.5	1.5	1.5	1.5	0.09	0.09	0	10	10	-10	120	FKM	E133F4450 ₁	2995	481865	8	9	2.1	3509
	1.5	1.5	1.5	1.5	0.09	0.09	0	10	10	-10	120	FKM	E133F44	4270	481000	8	8	2.1	3509
	1.5	1.5	1.5	1.5	0.09	0.09	0	10	10	-10	100	FKM	E133F44	2995	481865	8	9	2.1	3509
	2	2	2.5	2.5	0.15	0.15	0	7	7	-10	120	FKM	133F46	4270	481000	8	8	2.1	3509
	2	2	2.5	2.5	0.15	0.15	0	7	7	-10	100	FKM	133F46	2995	481865	8	9	2.1	3509
	2.5	2.5	3.5	3.5	0.21	0.21	0	4	4	-10	120	FKM	E133F43	4270	481000	8	8	2.1	3509
	2.5	2.5	3.5	3.5	0.21	0.21	0	4	4	-10	100	FKM	E133F43	2995	481865	8	9	2.1	3509

Notes:

1. With manual override



For this page	Port size	Orifice (mm)	Kv (l/min)	MOPD (bar)	Fluid Temp (°C)	Amb Temp (°C)
From	SB	1.5	1.5	4	-10	-10
To	SB	2.5	3.5	10	120	50

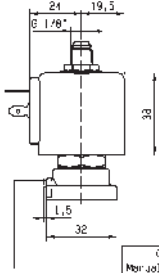
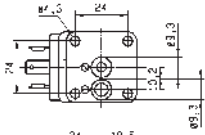

OPTICA
Módulo de control
121...131F...50

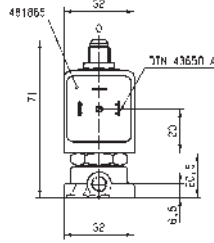

Drawing 3509

3/2

VALVES FOR DRY OR LUBRICATED AIR, NEUTRAL GASES AND LIQUIDS
DIRECT OPERATED

ANODIZED ALUMINIUM

BANJO

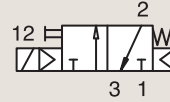

NORMALLY CLOSED

Port size	Orifice Ø 1	Flow factor Qn l/min	Operating Pressure Differential		Fluid Temp.		Seat Seal	Valve Ref.	Parker LUCIFER® Valves			Power		Coil Group	Dwg. No.
			Min bar	Max (MOPD) AC bar DC bar	Min °C	Max °C			Housing Ref.	Coil Ref.	AC W	DC W			
1/8"	1.2	50	0	10 10	-10 50	NBR	131B14 ₁₂	-	496131	3	3	1.2	8227		
	1.2	50	0	10 10	-10 50	NBR	131B14 ₁₂	-	496482	3	3	1.2	8227		
	1.2	50	0	10 10	-10 50	NBR	131B14 ₁₂	-	496637	3	3	1.2	8227		

Notes:

1. Valve only compatible with air and neutral gases
2. With manual override

ANODIZED ALUMINIUM

BANJO

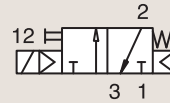

NORMALLY CLOSED

Port size	Orifice Ø 1	Flow factor Qn l/min	Operating Pressure Differential		Fluid Temp.		Seat Seal	Valve Ref.	Parker LUCIFER® Valves			Power		Coil Group	Dwg. No.
			Min bar	Max (MOPD) AC bar DC bar	Min °C	Max °C			Housing Ref.	Coil Ref.	AC W	DC W			
1/4"	1.2	50	0	10 10	-10 50	NBR	131B04 ₁₂	-	496131	3	3	1.2	8226		
	1.2	50	0	10 10	-10 50	NBR	131B04 ₁₂	-	496482	3	3	1.2	8226		
	1.2	50	0	10 10	-10 50	NBR	131B04 ₁₂	-	496637	3	3	1.2	8226		

Notes:

1. Valve only compatible with air and neutral gases
2. With manual override



For this page	Port size	Orifice (mm)	Qn (l/min)	MOPD (bar)	Fluid Temp (°C)	Amb Temp (°C)
From	1/8"	1.2	50	10	-10	-10
To	1/8"	1.2	50	10	50	50

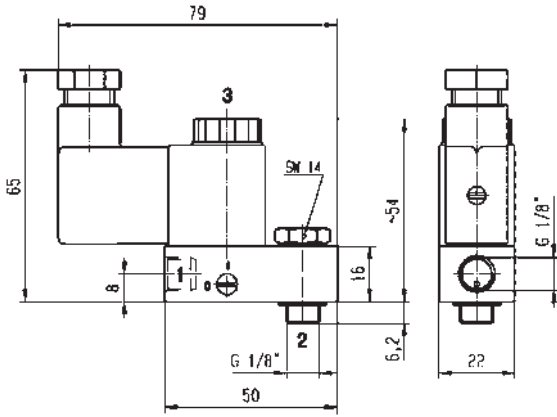

Drawing 8227

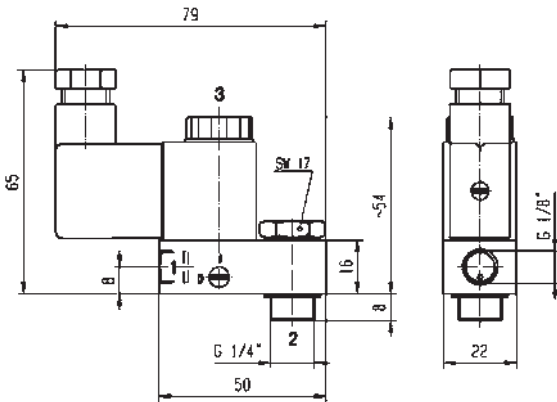

Drawing 8226

3 WAY VALVES

3/2

VALVES FOR DRY OR LUBRICATED AIR, NEUTRAL GASES AND LIQUIDS
DIRECT OPERATED

303 STAINLESS ST.
SUB-BASE MOUNTING

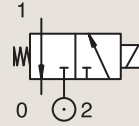

NORMALLY CLOSED

Port size	Orifice Ø		Flow factors				Operating Pressure Differential			Fluid Temp.		Seat Seal	Parker LUCIFER® Valves			Power		Coil Group	Dwg. No.
	1	(2)	1	(2)	1	(2)	Min	Max (MOPD)		Min	Max		Valve Ref.	Housing Ref.	Coil Ref.	AC	DC		
	mm		Kv l/min		KV l/min		bar	AC	DC	°C	°C					W	W		
SB	1.5	1.5	1.5	2.2	0.09	0.13	0	15	15	-10	100	NBR	131F5406	2995	481865	8	9	2.1	3509



For this page	Port size	Orifice (mm)	Kv (l/min)	MOPD (bar)	Fluid Temp (°C)	Amb Temp (°C)
From	SB	1.5	1.5	15	-10	-10
To	SB	1.5	1.5	15	100	50

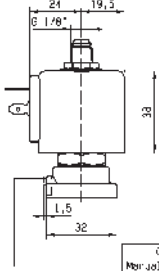
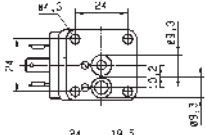

OPTICA
Materiale: Invar 360
121...131F...50

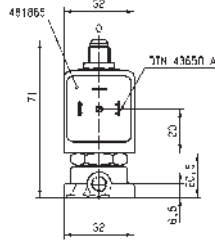

Drawing 3509

3/2

VALVES FOR DRY OR LUBRICATED AIR, NEUTRAL GASES AND LIQUIDS
DIRECT OPERATED

POM

SUB-BASE MOUNTING

NORMALLY CLOSED

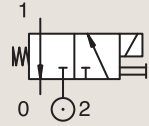

Port size	Orifice Ø		Flow factors				Operating Pressure Differential			Fluid Temp.		Seat Seal	Parker LUCIFER® Valves			Power		Coil Group	Dwg. No.
	1	(2)	1	(2)	1	(2)	Min	Max (MOPD)		Min	Max		Valve Ref.	Housing Ref.	Coil Ref.	AC W	DC W		
	mm		Kv l/min		KV l/min		bar	AC bar	DC bar	°C	°C								
SB	2	2	2	2	0.12	0.12	0	10	10	-10	50	FKM	E131F26 ₁₂	2995	481865	8	9	2.1/3.0	3601
	2	2	2	2	0.12	0.12	0	10	10	-10	50	FKM	E131F26 ₂	2995	482730	6	7	2.1/3.0	3601

Notes:

- 1. 20% Switch-on - max. 2 min
- 2. With manual override



For this page	Port size	Orifice (mm)	Kv (l/min)	MOPD (bar)	Fluid Temp (°C)	Amb Temp (°C)
From	SB	2	2	10	-10	-10
To	SB	2	2	10	50	50

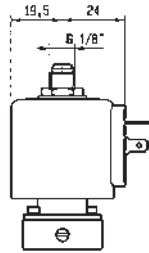
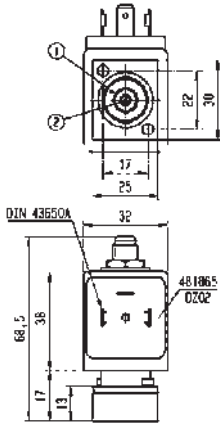

Drawing 3601

3/2

VALVES FOR DRY OR LUBRICATED AIR, NEUTRAL GASES AND LIQUIDS
PILOT OPERATED



Industrial Equipment



Process

ANODIZED ALUMINIUM PIPE MOUNTING

NORMALLY CLOSED

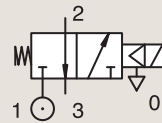

Port size	Orifice Ø		Flow factors				Operating Pressure Differential			Fluid Temp.		Seat Seal	Parker LUCIFER® Valves			IS	Power		Coil Group	Dwg. No.
	1	(2)	1	(2)	1	(2)	Min	Max (MOPD)	Min	Max	Valve Ref.		Housing Ref.	Coil Ref.	AC W		DC W			
	mm		Kv	l/min	KV	l/min	bar	AC bar	DC bar	°C								°C		
BSP	6.5	6.5	10	-	0.6	-	1	-	10	-10	55	NBR	331B7490 ₁	2995	483580.01	*	-	0.5 to 3	7.0/8.0	8270
	6.5	6.5	10	-	0.6	-	1	-	10	-10	75	NBR	331B7490 ₁	-	488660.01	*	-	0.3 to 3	7.0/8.0	8270
	6.5	6.5	10	-	0.6	-	1	-	10	-10	75	NBR	331B7490 ₁	-	495910	*	-	0.3 to 3	7.0/8.0	8270
1/4"	6.5	-	10	-	0.6	-	1	10	10	-10	75	NBR	E331B74 ₁₃	2995	481865		8	9	2.1	3240
	6.5	-	10	-	0.6	-	1	10	10	-10	75	NBR	E331B74 ₁₃	4270	485100		8	8	2.1	3240
	8	8	20	20	1.2	1.2	1	15	15	-10	75	FKM	E331B01 ₂	4270	481000		8	8	2.1	3234
	8	8	20	20	1.2	1.2	1	15	15	-10	75	FKM	E331B01 ₂	2995	481865		8	9	2.1	3234
	8	8	20	20	1.2	1.2	1	15	15	-10	75	FKM	E331B01 ₂	-	483371		8	8	2.1	3234

Notes:

- 1. Valve only compatible with air and neutral gases
- 2. Valve only compatible with hydraulic oil and air/neutral gases
- 3. With manual override



For this page	Port size	Orifice (mm)	Kv (l/min)	MOPD (bar)	Fluid Temp (°C)	Amb Temp (°C)
From	1/4"	6.5	10	10	-10	-10
To	1/4"	8	20	15	75	50

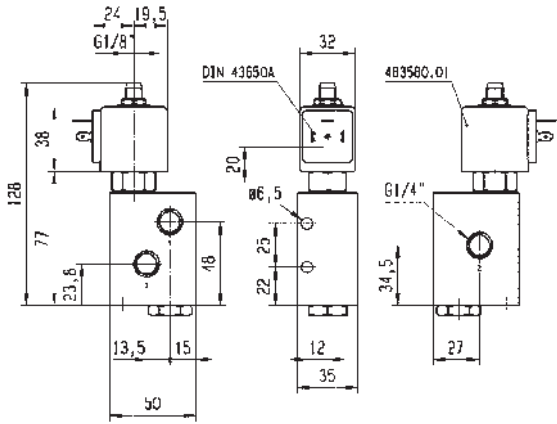

Drawing 8270

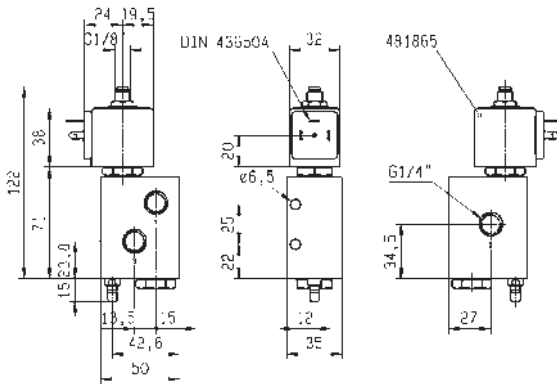

Weight: 0.51 kg

Drawing 3240

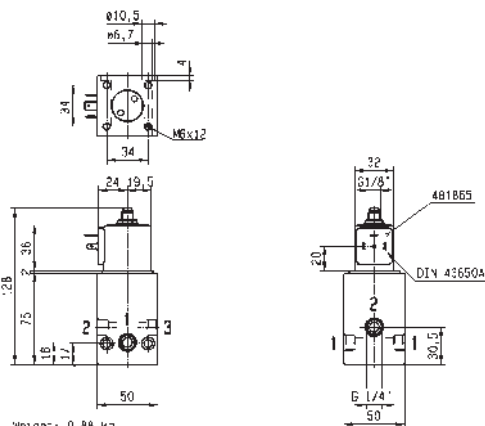

Weight: 0.88 kg



Drawing 3234

3/2

VALVES FOR DRY OR LUBRICATED AIR, NEUTRAL GASES AND LIQUIDS
PILOT OPERATED

ANODIZED ALUMINIUM
PIPE MOUNTING

NORMALLY CLOSED

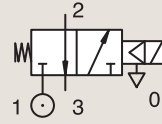

Port size	Orifice Ø		Flow factors		Operating Pressure Differential			Fluid Temp.		Seat Seal	Parker LUCIFER® Valves			Power		Coil Group	Dwg. No.		
	1	(2)	1	(2)	1	(2)	Min	Max (MOPD)	Min		Max	Valve Ref.	Housing Ref.	Coil Ref.	AC W			DC W	
BSP	mm		Kv l/min		KV l/min		bar	AC bar	DC bar	°C	°C								
1/2"	14	14	-	-	-	-	1	15	-	-10	75	FKM	E331B21 ₁	2995	482722	10	-	2.1	3238
	14	14	-	-	-	-	1	15	15	-10	75	FKM	E331B21 ₁	-	483371	8	8	2.1	3238

Notes:

1. Valve only compatible with air and neutral gases

ANODIZED ALUMINIUM
PIPE MOUNTING

NORMALLY OPEN

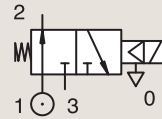

Port size	Orifice Ø		Flow factors		Operating Pressure Differential			Fluid Temp.		Seat Seal	Parker LUCIFER® Valves			Power		Coil Group	Dwg. No.		
	1	(2)	1	(2)	1	(2)	Min	Max (MOPD)	Min		Max	Valve Ref.	Housing Ref.	Coil Ref.	AC W			DC W	
BSP	mm		Kv l/min		KV l/min		bar	AC bar	DC bar	°C	°C								
1/4"	8	8	10	10	0.6	0.6	1	40	40	-10	75	PCTFE	332B02 ₁₂	2995	481865	8	9	2.1	8114
	8	8	10	10	0.6	0.6	1	40	40	-10	75	PCTFE	332B02 ₁₂	4270	481000	8	8	2.1	8114
	8	8	20	20	1.2	1.2	1	15	15	-10	75	FKM	E332B01 ₂	2995	481865	8	9	2.1	3234
	8	8	20	20	1.2	1.2	1	15	15	-10	75	FKM	E332B01 ₂	4270	481000	8	8	2.1	3234
	8	8	20	20	1.2	1.2	1	15	15	-10	75	FKM	E332B01 ₂	-	483371	8	8	2.1	3234

Notes:

1. Pilot seat discs in Kel-F (PCTFE); valve with pilot return pipe
2. Valve only compatible with hydraulic oil and air/neutral gases



For this page	Port size	Orifice (mm)	Kv (l/min)	MOPD (bar)	Fluid Temp (°C)	Amb Temp (°C)
From	1/4"	8	10	15	-10	-10
To	1/2"	14	20	40	75	50

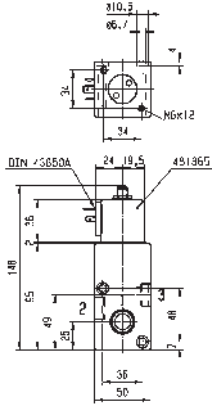

Weight: 0,98 kg

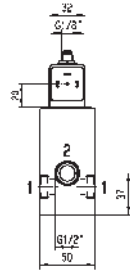

Drawing 3238

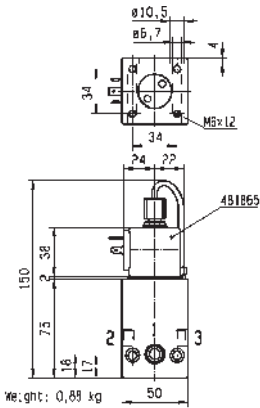

Weight: 0,88 kg

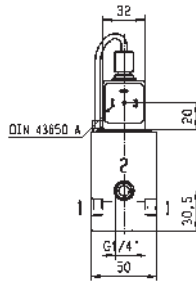

Drawing 8114

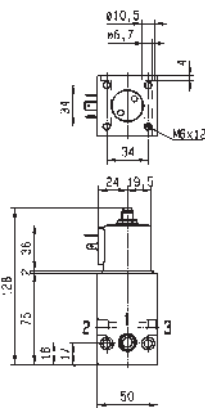

Weight: 0,88 kg

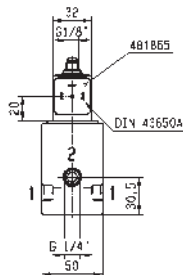

Drawing 3234

3/2

VALVES FOR DRY OR LUBRICATED AIR, NEUTRAL GASES AND LIQUIDS
PILOT OPERATED

ANODIZED ALUMINIUM PIPE MOUNTING

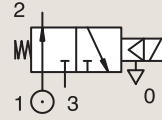

NORMALLY OPEN

Port size	Orifice Ø		Flow factor	Operating Pressure Differential			Fluid Temp.		Seat Seal	Parker LUCIFER® Valves			Power		Coil Group	Dwg. No.
	1	(2)		Min	Max (MOPD)		Min	Max		Valve Ref.	Housing Ref.	Coil Ref.	AC W	DC W		
BSP	mm		Qn l/min	bar	AC bar	DC bar	°C	°C								
1/2"	14	14	2500	1	15	15	-10	100	FKM	E332B21 ₁	2995	481865	8	9	2.1	3238
	14	14	2500	1	15	15	-10	100	FKM	E332B21 ₁	4270	481000	8	8	2.1	3238

Notes:

1. Valve only compatible with air and neutral gases

ANODIZED ALUMINIUM SUB-BASE MOUNTING

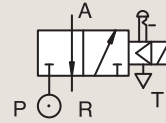

NORMALLY CLOSED

Port size	Orifice Ø		Flow factor	Operating Pressure Differential			Fluid Temp.		Seat Seal	Parker LUCIFER® Valves			Power		Coil Group	Dwg. No.
	1	(2)		Min	Max (MOPD)		Min	Max		Valve Ref.	Housing Ref.	Coil Ref.	AC W	DC W		
SB	mm		Qn l/min	bar	AC bar	DC bar	°C	°C								
SB	15	15	5000	0.5	10	10	-10	75	FKM	E331L21 ₁	2995	481865	8	9	2.1/3.0	3130
	15	15	5000	0.5	10	10	-10	75	FKM	E331L21 ₁	-	483371	8	8	2.1/3.0	3130

Notes:

1. With manual override



For this page	Port size	Orifice (mm)	Qn (l/min)	MOPD (bar)	Fluid Temp (°C)	Amb Temp (°C)
From	1/2"	14	-	10	-10	-10
To	1/2"	15	5000	15	100	50

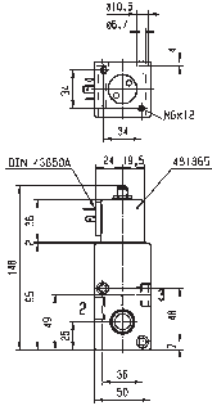

Weight: 0.98 kg

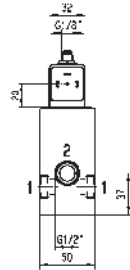

Drawing 3238

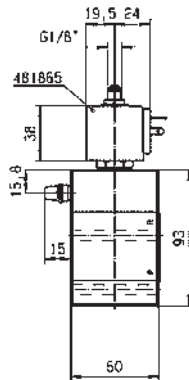
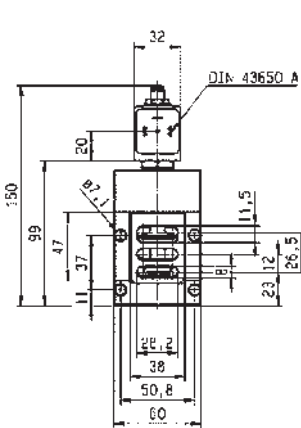

Drawing 3130

3 WAY VALVES



VALVES FOR HYDRAULIC OIL AND NEUTRAL LIQUIDS (UP TO 75 BAR)



3/2

Actuation	Body	Function	Port Size	Orifice (mm)	Flow Factor Kv(l/min)	MOPD (bar)	Max Fluid Temp. (°C)	Page Parker Valves	Page Parker LUCIFER® Valves
Pilot Operated	Anodized aluminium/ Pipe mounting	Normally Closed	1/4"	8	10	40	75	-	248

3/2

VALVES FOR HYDRAULIC OIL AND NEUTRAL LIQUIDS (UP TO 75 BAR) PILOT OPERATED



Process



Industrial Equipment

ANODIZED ALUMINIUM PIPE MOUNTING

NORMALLY CLOSED

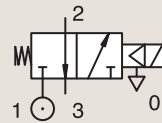

Port size	Orifice Ø		Flow factors				Operating Pressure Differential			Fluid Temp.		Seat Seal	Parker LUCIFER® Valves			Power		Coil Group	Dwg. No.
	1	(2)	1	(2)	1	(2)	Min	Max (MOPD)	DC	Min	Max		Valve Ref.	Housing Ref.	Coil Ref.	AC W	DC W		
BSP	mm		Kv		KV		bar	AC bar	DC bar	°C	°C								
1/4"	8	8	10	10	0.6	0.6	1	40	40	-10	75	NBR	331B02 ₁₂	2995	481865	8	9	2.1	8114
	8	8	10	10	0.6	0.6	1	40	40	-10	75	NBR	331B02 ₁₂	4270	481000	8	8	2.1	8114
	8	8	10	10	0.6	0.6	1	40	40	-10	75	NBR	331B0216 ₁₃	2995	481865	8	9	2.1	8114
	8	8	10	10	0.6	0.6	1	40	40	-10	75	NBR	331B0216 ₁₃	4270	481000	8	8	2.1	8114

Notes:

1. Pilot seat discs in Kel-F (PCTFE); valve with pilot return pipe
2. Valve only compatible with hydraulic oil
3. Valve only compatible with air / neutral gases



For this page	Port size	Orifice (mm)	Kv (l/min)	MOPD (bar)	Fluid Temp (°C)	Amb Temp (°C)
From	1/4"	8	10	40	-10	-10
To	1/4"	8	10	40	75	50

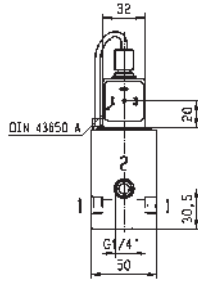
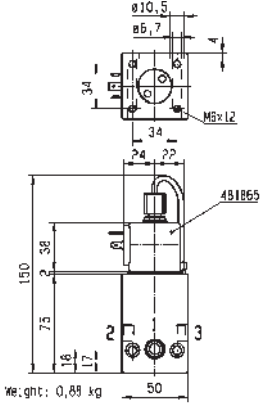

Drawing 8114

3 WAY VALVES



HIGH CORROSION RESISTANT VALVES (303 STAINLESS STEEL)



3/2

Actuation	Body	Function	Port Size	Orifice (mm)	Flow Factor Kv(l/min)	MOPD (bar)	Max Fluid Temp. (°C)	Page Parker Valves	Page Parker LUCIFER® Valves
Direct Operated	303 Stainless St./Pipe mounting	Normally Closed	1/4"	1 to 2.5	3.5	15	180	-	252
			1/4"	1 to 2.5	3.5	15	180	-	252
		Universal	1/4"	1.5 to 2.5	3.5	10	180	-	254

3/2

HIGH CORROSION RESISTANT VALVES (303 STAINLESS STEEL) DIRECT OPERATED



Process

303 STAINLESS ST. PIPE MOUNTING

NORMALLY CLOSED

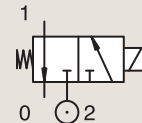

Port size	Orifice Ø		Flow factors				Operating Pressure Differential			Fluid Temp.		Seat Seal	Parker LUCIFER® Valves			IS	Power		Coil Group	Dwg. No.
	1	(2)	1	(2)	1	(2)	Min	Max (MOPD)		Min	Max		Valve Ref.	Housing Ref.	Coil Ref.		AC W	DC W		
								AC bar	DC bar											
1/4"	1	1	0.6	0.6	0.03	0.03	0	-	10	-10	55	FKM	131V5490	2995	483580.01	*	-	0.5 to 3	7.0/8.0	6740
	1	1	0.6	0.6	0.03	0.03	0	-	10	-10	75	FKM	131V5490	-	488660.01	*	-	0.3 to 3	7.0/8.0	6740
	1	1	0.6	0.6	0.03	0.03	0	-	10	-10	75	FKM	131V5490	-	495910	*	-	0.3 to 3	7.0/8.0	6740
	1.5	1.5	1.5	1.5	0.09	0.09	0	15	15	-10	120	FKM	131V5406	4270	481000		8	8	2.1	8116
	1.5	1.5	1.5	1.5	0.09	0.09	0	15	15	-10	100	FKM	131V5406	2995	481865		8	9	2.1	8116
	1.5	1.5	1.5	1.5	0.09	0.09	0	15	15	0	130	Ruby	131V5463 ₁	4270	481000		8	8	2.0	8116
	1.5	1.5	1.5	1.5	0.09	0.09	0	15	15	0	100	Ruby	131V5463 ₁	2995	481865		8	9	2.0	8116
	1.5	1.5	1.5	1.5	0.09	0.09	0	15	15	0	180	Ruby	131V5463 ₁	4270	486265		14	14	2.0	8116
	1.5	1.5	1.5	1.5	0.09	0.09	0	-	7	-20	75	PUR	131V5497	2995	482740		-	1.6	3.0/6.0/8.0	8024
	1.5	1.5	1.5	1.5	0.09	0.09	0	7	7	-20	75	PUR	131V5497	-	495900		2.5	2	3.0/6.0/8.0	8024
	1.5	1.5	1.5	1.5	0.09	0.09	0	-	7	-20	75	PUR	131V5497	-	495910	*	-	0.3 to 3	3.0/6.0/8.0	8024
	1.5	1.5	1.5	1.5	0.09	0.09	0	-	7	-20	75	PUR	131V5497	2995	496125		-	1.6	3.0/6.0/8.0	8024
	2.5	2.5	3.5	3.5	0.21	0.21	0	7	7	-10	120	FKM	131V5306	4270	481000		8	8	2.1	8116
	2.5	2.5	3.5	3.5	0.21	0.21	0	7	7	-10	100	FKM	131V5306	2995	481865		8	9	2.1	8116
	2.5	2.5	3.5	3.5	0.21	0.21	0	7	7	-30	130	Ruby	131V5363 ₁	4270	481000		8	8	2.0	8116
	2.5	2.5	3.5	3.5	0.21	0.21	0	7	7	-30	100	Ruby	131V5363 ₁	2995	481865		8	9	2.0	8116
	2.5	2.5	3.5	3.5	0.21	0.21	0	7	7	-30	180	Ruby	131V5363 ₁	4270	486265		14	14	2.0	8116
	2.5	2.5	3	3	0.18	0.18	0	-	2	-20	75	PUR	131V5397	2995	482740		-	1.6	6.0/8.0	8024
	2.5	2.5	3	3	0.18	0.18	0	2	2	-20	75	PUR	131V5397	-	495900		2.5	2	6.0/8.0	8024
	2.5	2.5	3	3	0.18	0.18	0	-	2	-20	75	PUR	131V5397	-	495910	*	-	0.3 to 3	6.0/8.0	8024
2.5	2.5	3	3	0.18	0.18	0	-	2	-20	75	PUR	131V5397	2995	496125		-	1.6	6.0/8.0	8024	

Notes:

1. Valve only compatible with hydraulic oil and neutral liquids



For this page	Port size	Orifice (mm)	Kv (l/min)	MOPD (bar)	Fluid Temp (°C)	Amb Temp (°C)
From	1/4"	1	0.6	2	-30	-20
To	1/4"	2.5	3.5	15	180	50

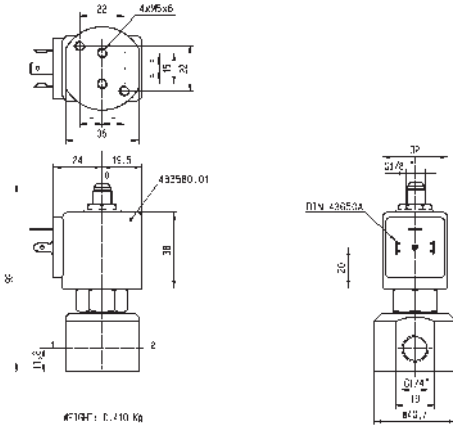

Drawing 6740

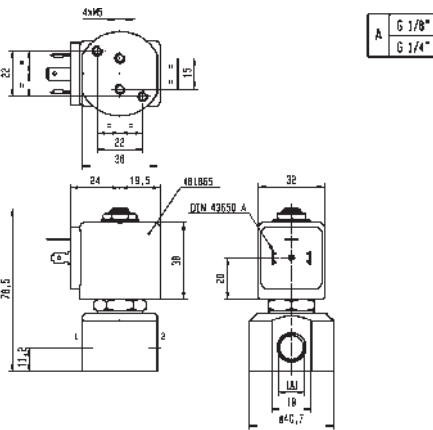

Drawing 8116

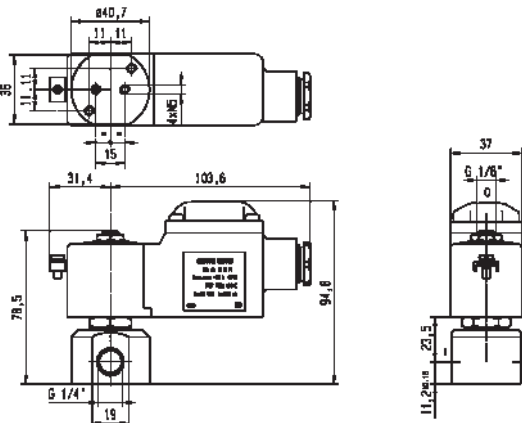

Drawing 8024

3/2

HIGH CORROSION RESISTANT VALVES (303 STAINLESS STEEL) DIRECT OPERATED

303 STAINLESS ST.
PIPE MOUNTING

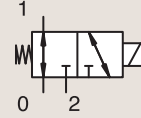

UNIVERSAL

Port size	Orifice Ø		Flow factors			Operating Pressure Differential			Fluid Temp.		Seat Seal	Parker LUCIFER® Valves			Power		Coil Group	Dwg. No.	
	1	(2)	1	(2)	1	(2)	Min	Max (MOPD)	Min	Max		Valve Ref.	Housing Ref.	Coil Ref.	AC W	DC W			
BSP	mm		Kv l/min	KV m³/h	bar	AC bar	DC bar	°C	°C										
1/4"	1.5	1.5	1.5	1.5	0.09	0.09	0	10	10	-10	120	FKM	133V5406	4270	481000	8	8	2.1	8116
	1.5	1.5	1.5	1.5	0.09	0.09	0	10	10	-10	100	FKM	133V5406	2995	481865	8	9	2.1	8116
	1.5	1.5	1.5	1.5	0.09	0.09	0	10	10	0	130	Ruby	133V5463 ₁	4270	481000	8	8	2.0	8116
	1.5	1.5	1.5	1.5	0.09	0.09	0	4	4	0	100	Ruby	133V5463 ₁	2995	481865	8	9	2.0	8116
	1.5	1.5	1.5	1.5	0.09	0.09	0	10	10	0	180	Ruby	133V5463 ₁	4270	486265	14	14	2.0	8116
	2.5	2.5	3.5	3.5	0.21	0.21	0	4	4	-10	120	FKM	133V5306	4270	481000	8	8	2.1	8116
	2.5	2.5	3.5	3.5	0.21	0.21	0	4	4	-10	100	FKM	133V5306	2995	481865	8	9	2.1	8116
	2.5	2.5	3.5	3.5	0.21	0.21	0	4	4	0	130	Ruby	133V5363 ₁	4270	481000	8	8	2.0	8116
	2.5	2.5	3.5	3.5	0.21	0.21	0	4	4	0	100	Ruby	133V5363 ₁	2995	481865	8	9	2.0	8116
	2.5	2.5	3.5	3.5	0.21	0.21	0	4	4	0	180	Ruby	133V5363 ₁	4270	486265	14	14	2.0	8116

Notes:

1. Valve only compatible with hydraulic oil and neutral liquids



For this page	Port size	Orifice (mm)	Kv (l/min)	MOPD (bar)	Fluid Temp (°C)	Amb Temp (°C)
From	1/4"	1.5	1.5	4	-10	-10
To	1/4"	2.5	3.5	10	180	50

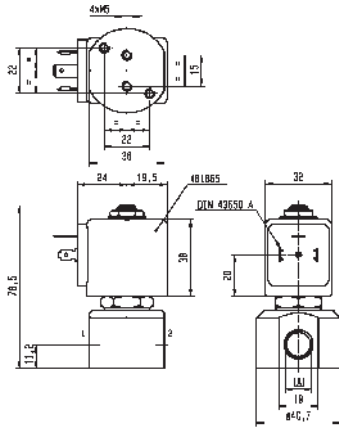

A	G 1/8"
	G 1/4"



Drawing 8116

3 WAY VALVES



VALVES FOR BEVERAGE DISPENSING - LIQUIPURE®



Steam



Water

3/2

Actuation	Body	Function	Port Size	Orifice (mm)	Flow Factor Kv(l/min)	MOPD (bar)	Max Fluid Temp. (°C)	Page Parker Valves
Direct Operated	Stainless St./Sub-base mounting	Normally Closed	SB	1.5 to 3	4.2	14	140	258

3/2

VALVES FOR BEVERAGE DISPENSING - LIQUIPURE® DIRECT OPERATED



Beverage Dispensing



Medical / Instrumentation

STAINLESS ST. SUB-BASE MOUNTING

NORMALLY CLOSED

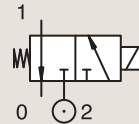

Port size	Orifice Ø		Flow factors			Operating Pressure Differential			Fluid Temp.		Seat Seal	Parker Valves			Power		Coil Group	Dwg. No.	
	1	(2)	1	(2)	1	(2)	Min	Max (MOPD)	Min	Max		Valve Ref.	Housing Ref.	Coil Ref.	AC W	DC W			
BSP	mm		Kv	(2)	KV	(2)	bar	AC bar	DC bar	°C	°C								
	1.5	2.5	1.3	-	0.08	-	0	14	14	-10	140	Ruby	3019F1GRG7	-	D4	13	16	24.0	072
	1.5	2.5	1.3	-	0.08	-	0	14	14	-10	140	Ruby	3019F1GRG7	-	D5	8	9	24.0	072
	1.5	2.5	1.3	-	0.08	-	0	14	14	-10	140	Ruby	3019F1GRG7	-	LA	9	9	24.0	072
	1.5	2.5	1.3	-	0.08	-	0	14	14	-10	140	Ruby	3019F1GRG7	-	LB-LC	13	16	24.0	072
	1.5	2.5	1.3	-	0.08	-	0	14	-	-10	140	Ruby	3019F1GRG7	-	XS03	9	-	24.0	072
	1.5	2.5	1.3	-	0.08	-	0	14	14	-10	140	FDA FKM	3019F1GVG7	-	D4	13	16	24.0	072
	1.5	2.5	1.3	-	0.08	-	0	14	14	-10	140	FDA FKM	3019F1GVG7	-	D5	8	9	24.0	072
	1.5	2.5	1.3	-	0.08	-	0	14	14	-10	140	FDA FKM	3019F1GVG7	-	LA	9	9	24.0	072
	1.5	2.5	1.3	-	0.08	-	0	14	14	-10	140	FDA FKM	3019F1GVG7	-	LB-LC	13	16	24.0	072
	1.5	2.5	1.3	-	0.08	-	0	14	-	-10	140	FDA FKM	3019F1GVG7	-	XS03	9	-	24.0	072
	1.5	2.5	1.3	-	0.08	-	0	14	14	-10	140	Ruby	301XGFRTG7	-	D4	13	16	24.0	073
	1.5	2.5	1.3	-	0.08	-	0	14	14	-10	140	Ruby	301XGFRTG7	-	D5	8	9	24.0	073
	1.5	2.5	1.3	-	0.08	-	0	14	14	-10	140	Ruby	301XGFRTG7	-	LA	9	9	24.0	073
	1.5	2.5	1.3	-	0.08	-	0	14	14	-10	140	Ruby	301XGFRTG7	-	LB-LC	13	16	24.0	073
	1.5	2.5	1.3	-	0.08	-	0	14	-	-10	140	Ruby	301XGFRTG7	-	XS03	9	-	24.0	073
	1.5	2.5	1.3	-	0.08	-	0	14	14	-10	140	FDA FKM	301XGFVTG7	-	D4	13	16	24.0	073
	1.5	2.5	1.3	-	0.08	-	0	14	14	-10	140	FDA FKM	301XGFVTG7	-	D5	8	9	24.0	073
	1.5	2.5	1.3	-	0.08	-	0	14	14	-10	140	FDA FKM	301XGFVTG7	-	LA	9	9	24.0	073
	1.5	2.5	1.3	-	0.08	-	0	14	14	-10	140	FDA FKM	301XGFVTG7	-	LB-LC	13	16	24.0	073
	1.5	2.5	1.3	-	0.08	-	0	14	-	-10	140	FDA FKM	301XGFVTG7	-	XS03	9	-	24.0	073
	2	2.5	2.2	-	0.13	-	0	10	10	-10	140	Ruby	3019F1JRG7	-	D4	13	16	24.0	072
	2	2.5	2.2	-	0.13	-	0	10	10	-10	140	Ruby	3019F1JRG7	-	D5	8	9	24.0	072
	2	2.5	2.2	-	0.13	-	0	10	10	-10	140	Ruby	3019F1JRG7	-	LA	9	9	24.0	072
	2	2.5	2.2	-	0.13	-	0	10	10	-10	140	Ruby	3019F1JRG7	-	LB-LC	13	16	24.0	072



For this page	Port size	Orifice (mm)	Kv (l/min)	MOPD (bar)	Fluid Temp (°C)	Amb Temp (°C)
From	SB	1.5	1.3	10	-10	-10
To	SB	2	2.2	14	140	50



Drawing 072



Drawing 073

3/2

VALVES FOR BEVERAGE DISPENSING - LIQUIPURE® DIRECT OPERATED

STAINLESS ST.
SUB-BASE MOUNTING

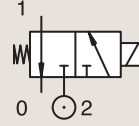

NORMALLY CLOSED

Port size	Orifice Ø		Flow factors			Operating Pressure Differential			Fluid Temp.		Seat Seal	Parker Valves			Power		Coil Group	Dwg. No.		
	1	(2)	1	(2)	1	(2)	Min	Max (MOPD)	Min	Max		Valve Ref.	Housing Ref.	Coil Ref.	AC W	DC W				
BSP	mm		Kv l/min		KV m³/h		bar	AC bar	DC bar	°C	°C									
BSP	2	2.5	2.2	-	0.13	-	0	10	10	-10	140	Ruby	3019F1JRG7	-	XS03	9	-	24.0	072	
	2	2.5	2.2	-	0.13	-	0	10	10	-10	140	FDA FKM	3019F1JVG7	-	D4	13	16	24.0	072	
	2	2.5	2.2	-	0.13	-	0	10	10	-10	140	FDA FKM	3019F1JVG7	-	D5	8	9	24.0	072	
	2	2.5	2.2	-	0.13	-	0	10	10	-10	140	FDA FKM	3019F1JVG7	-	LA	9	9	24.0	072	
	2	2.5	2.2	-	0.13	-	0	10	10	-10	140	FDA FKM	3019F1JVG7	-	LB-LC	13	16	24.0	072	
	2	2.5	2.2	-	0.13	-	0	10	-	-10	140	FDA FKM	3019F1JVG7	-	XS03	9	-	24.0	072	
	2	2.5	2.2	-	0.13	-	0	10	10	-10	140	Ruby	301XGFRTJ7	-	D4	13	16	24.0	073	
	2	2.5	2.2	-	0.13	-	0	10	10	-10	140	Ruby	301XGFRTJ7	-	D5	8	9	24.0	073	
	2	2.5	2.2	-	0.13	-	0	10	10	-10	140	Ruby	301XGFRTJ7	-	LA	9	9	24.0	073	
	2	2.5	2.2	-	0.13	-	0	10	10	-10	140	Ruby	301XGFRTJ7	-	LB-LC	13	16	24.0	073	
	2	2.5	2.2	-	0.13	-	0	10	-	-10	140	Ruby	301XGFRTJ7	-	XS03	9	-	24.0	073	
	2	2.5	2.2	-	0.13	-	0	10	10	-10	140	FDA FKM	301XGFVTJ7	-	D4	13	16	24.0	073	
	2	2.5	2.2	-	0.13	-	0	10	10	-10	140	FDA FKM	301XGFVTJ7	-	D5	8	9	24.0	073	
	2	2.5	2.2	-	0.13	-	0	10	10	-10	140	FDA FKM	301XGFVTJ7	-	LA	9	9	24.0	073	
	2	2.5	2.2	-	0.13	-	0	10	10	-10	140	FDA FKM	301XGFVTJ7	-	LB-LC	13	16	24.0	073	
	2	2.5	2.2	-	0.13	-	0	10	-	-10	140	FDA FKM	301XGFVTJ7	-	XS03	9	-	24.0	073	
	SB	2.5	2.5	2.8	-	0.17	-	0	6.5	6.5	-10	140	Ruby	3019F1LRG7	-	D4	13	16	24.0	072
		2.5	2.5	2.8	-	0.17	-	0	6.5	6.5	-10	140	Ruby	3019F1LRG7	-	D5	8	9	24.0	072
		2.5	2.5	2.8	-	0.17	-	0	6.5	6.5	-10	140	Ruby	3019F1LRG7	-	LA	9	9	24.0	072
		2.5	2.5	2.8	-	0.17	-	0	6.5	6.5	-10	140	Ruby	3019F1LRG7	-	LB-LC	13	16	24.0	072
		2.5	2.5	2.8	-	0.17	-	0	6.5	-	-10	140	Ruby	3019F1LRG7	-	XS03	9	-	24.0	072
		2.5	2.5	2.8	-	0.17	-	0	6.5	6.5	-10	140	FDA FKM	3019F1LVG7	-	D4	13	16	24.0	072
		2.5	2.5	2.8	-	0.17	-	0	6.5	6.5	-10	140	FDA FKM	3019F1LVG7	-	D5	8	9	24.0	072
		2.5	2.5	2.8	-	0.17	-	0	6.5	6.5	-10	140	FDA FKM	3019F1LVG7	-	LA	9	9	24.0	072
2.5		2.5	2.8	-	0.17	-	0	6.5	6.5	-10	140	FDA FKM	3019F1LVG7	-	LB-LC	13	16	24.0	072	
2.5		2.5	2.8	-	0.17	-	0	6.5	-	-10	140	FDA FKM	3019F1LVG7	-	XS03	9	-	24.0	072	
2.5		2.5	2.8	-	0.17	-	0	6.5	6.5	-10	140	Ruby	301XGFRTL7	-	D4	13	16	24.0	073	
2.5		2.5	2.8	-	0.17	-	0	6.5	6.5	-10	140	Ruby	301XGFRTL7	-	D5	8	9	24.0	073	
2.5		2.5	2.8	-	0.17	-	0	6.5	6.5	-10	140	Ruby	301XGFRTL7	-	LA	9	9	24.0	073	
2.5		2.5	2.8	-	0.17	-	0	6.5	6.5	-10	140	Ruby	301XGFRTL7	-	LB-LC	13	16	24.0	073	
2.5		2.5	2.8	-	0.17	-	0	6.5	-	-10	140	Ruby	301XGFRTL7	-	XS03	9	-	24.0	073	
2.5		2.5	2.8	-	0.17	-	0	6.5	6.5	-10	140	FDA FKM	301XGFRTL7	-	D4	13	16	24.0	073	
2.5		2.5	2.8	-	0.17	-	0	6.5	6.5	-10	140	FDA FKM	301XGFRTL7	-	D5	8	9	24.0	073	
2.5		2.5	2.8	-	0.17	-	0	6.5	6.5	-10	140	FDA FKM	301XGFRTL7	-	LA	9	9	24.0	073	
2.5		2.5	2.8	-	0.17	-	0	6.5	6.5	-10	140	FDA FKM	301XGFRTL7	-	LB-LC	13	16	24.0	073	



For this page	Port size	Orifice (mm)	Kv (l/min)	MOPD (bar)	Fluid Temp (°C)	Amb Temp (°C)
From	SB	2	2.2	6.5	-10	-10
To	SB	2.5	2.8	10	140	50

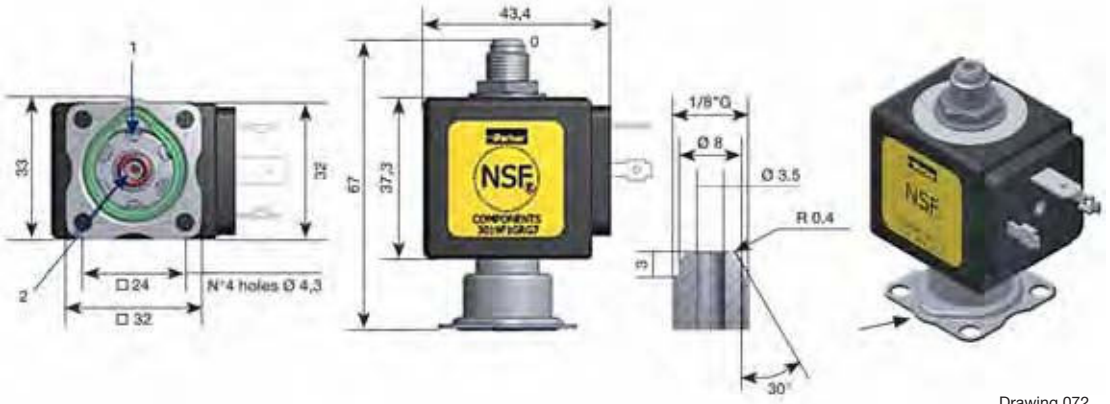

Drawing 072



Drawing 073

3/2

VALVES FOR BEVERAGE DISPENSING - LIQUIPURE® DIRECT OPERATED

STAINLESS ST.
SUB-BASE MOUNTING

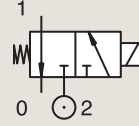

NORMALLY CLOSED

Port size	Orifice Ø		Flow factors				Operating Pressure Differential			Fluid Temp.		Seat Seal	Parker Valves			Power		Coil Group	Dwg. No.
	1	(2)	1	(2)	1	(2)	Min	Max (MOPD)	Min	Max	Valve Ref.		Housing Ref.	Coil Ref.	AC W	DC W			
BSP	mm		Kv l/min		KV m³/h		bar	AC bar	DC bar	°C	°C								
SB	2.5	2.5	2.8	-	0.17	-	0	6.5	-	-10	140	FDA FKM	301XGFVTL7	-	XS03	9	-	24.0	073
	3	2.5	3.8	-	0.2	-	0	4	4	-10	140	Ruby	3019F1NRG7	-	D4	13	16	24.0	072
	3	2.5	3.3	-	0.2	-	0	4	4	-10	140	Ruby	3019F1NRG7	-	D5	8	9	24.0	072
	3	2.5	3.3	-	0.2	-	0	4	4	-10	140	Ruby	3019F1NRG7	-	LA	9	9	24.0	072
	3	2.5	3.3	-	0.2	-	0	4	4	-10	140	Ruby	3019F1NRG7	-	LB-LC	13	16	24.0	072
	3	2.5	3.3	-	0.2	-	0	4	-	-10	140	Ruby	3019F1NRG7	-	XS03	9	-	24.0	072
	3	2.5	3.3	-	0.2	-	0	4	4	-10	140	FDA FKM	3019F1NVG7	-	D4	13	16	24.0	072
	3	2.5	3.3	-	0.2	-	0	4	4	-10	140	FDA FKM	3019F1NVG7	-	D5	8	9	24.0	072
	3	2.5	3.3	-	0.2	-	0	4	4	-10	140	FDA FKM	3019F1NVG7	-	LA	9	9	24.0	072
	3	2.5	3.3	-	0.2	-	0	4	4	-10	140	FDA FKM	3019F1NVG7	-	LB-LC	13	16	24.0	072
	3	2.5	3.3	-	0.2	-	0	4	-	-10	140	FDA FKM	3019F1NVG7	-	XS03	9	-	24.0	072
	3	2.5	4.2	-	0.25	-	0	4	4	-10	140	Ruby	301XGFRTN7	-	D4	13	16	24.0	073
	3	2.5	4.2	-	0.25	-	0	4	4	-10	140	Ruby	301XGFRTN7	-	D5	8	9	24.0	073
	3	2.5	4.2	-	0.25	-	0	4	4	-10	140	Ruby	301XGFRTN7	-	LA	9	9	24.0	073
	3	2.5	4.2	-	0.25	-	0	4	4	-10	140	Ruby	301XGFRTN7	-	LB-LC	13	16	24.0	073
	3	2.5	4.2	-	0.25	-	0	4	-	-10	140	Ruby	301XGFRTN7	-	XS03	9	-	24.0	073
	3	2.5	4.2	-	0.25	-	0	4	4	-10	140	FDA FKM	301XGFVTN7	-	D4	13	16	24.0	073
	3	2.5	4.2	-	0.25	-	0	4	4	-10	140	FDA FKM	301XGFVTN7	-	D5	8	9	24.0	073
	3	2.5	4.2	-	0.25	-	0	4	4	-10	140	FDA FKM	301XGFVTN7	-	LA	9	9	24.0	073
	3	2.5	4.2	-	0.25	-	0	4	4	-10	140	FDA FKM	301XGFVTN7	-	LB-LC	13	16	24.0	073
3	2.5	4.2	-	0.25	-	0	4	-	-10	140	FDA FKM	301XGFVTN7	-	XS03	9	-	24.0	073	



For this page	Port size	Orifice (mm)	Kv (l/min)	MOPD (bar)	Fluid Temp (°C)	Amb Temp (°C)
From	SB	2.5	2.8	4	-10	-10
To	SB	3	4.2	6.5	140	50



Drawing 073

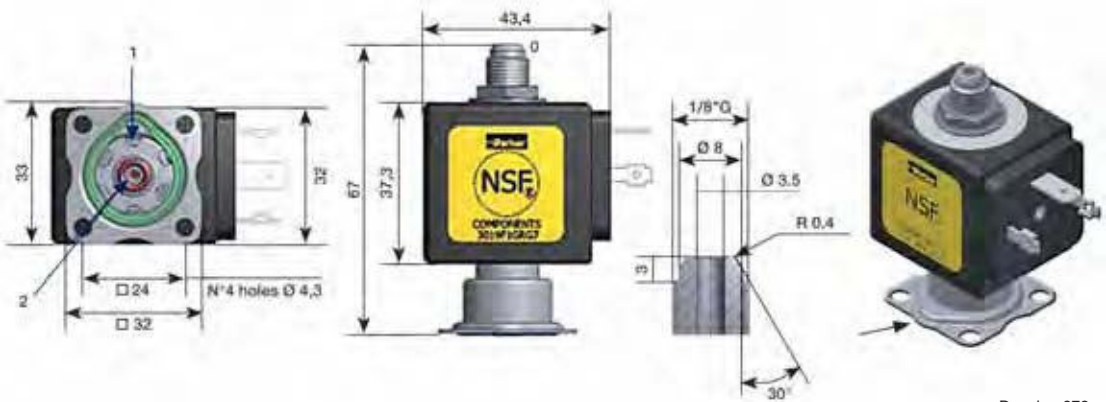

Drawing 072

2 & 3 WAY VALVES FOR TRANSPORTATION

2 & 3 WAY VALVES FOR TRANSPORTATION

2 WAY



Water

2/2

Actuation	Body	Function	Port Size	Orifice (mm)	Flow Factor Kv(l/min)	MOPD (bar)	Max Fluid Temp. (°C)	Page Parker Valves	Page Parker LUCIFER® Valves
Pilot Operated	Brass/Quick Coupling	Normally Closed	10 mm	11	12	3	90	-	266
	Brass/Barb Fitting	Normally Closed	10 mm	11	12	3	90	-	266
	Brass/Pipe Mounting	Normally Closed	12.7 mm	11	33	3	90	-	268
			15.9 mm	11	36	3	90	-	268

2/2

2 WAY
PILOT OPERATED



Transportation

BRASS QUICK COUPLING

NORMALLY CLOSED

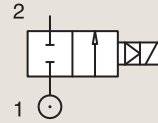

Port size	Orifice Ø mm	Flow factors			Operating Pressure Differential			Fluid Temp.		Seat Seal	Parker LUCIFER® Valves			Voltage		Power		Coil Group	Dwg. No.
		Kv l/min	KV m³/h	Qn l/min	Min bar	Max(MOPD)		Min °C	Max °C		Valve Ref.	Housing Ref.	Coil Ref.	12 VDC	24 VDC	AC W	DC W		
						AC bar	DC bar												
10 mm	11	12	0.72	-	0.2	-	3	-40	90	EPDM	321K1543	2168	495294	12 VDC	-	9	13.0	8242	
	11	12	0.72	-	0.2	-	3	-40	90	EPDM	321K1543	2169	495294	24 VDC	-	9	13.0	8242	
	11	12	0.72	-	0.2	-	3	-40	90	EPDM	321K1543	2168	496193	12 VDC	-	9	13.0	8242	
	11	12	0.72	-	0.2	-	3	-40	90	EPDM	321K1543	2169	496193	24 VDC	-	9	13.0	8242	

BRASS BARB FITTING

NORMALLY CLOSED

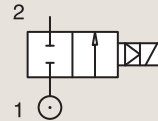

Port size	Orifice Ø mm	Flow factors			Operating Pressure Differential			Fluid Temp.		Seat Seal	Parker LUCIFER® Valves			Voltage		Power		Coil Group	Dwg. No.
		Kv l/min	KV m³/h	Qn l/min	Min bar	Max(MOPD)		Min °C	Max °C		Valve Ref.	Housing Ref.	Coil Ref.	12 VDC	24 VDC	AC W	DC W		
						AC bar	DC bar												
10 mm	11	12	0.72	-	0.2	-	3	-40	90	EPDM	321K1535	2168	495294	12 VDC	-	9	13.0	8241	
	11	12	0.72	-	0.2	-	3	-40	90	EPDM	321K1535	2169	495294	24 VDC	-	9	13.0	8241	
	11	12	0.72	-	0.2	-	3	-40	90	EPDM	321K1535	2168	496193	12 VDC	-	9	13.0	8241	
	11	12	0.72	-	0.2	-	3	-40	90	EPDM	321K1535	2169	496193	24 VDC	-	9	13.0	8241	



For this page	Port size	Orifice (mm)	Kv (l/min)	MOPD (bar)	Fluid Temp (°C)	Amb Temp (°C)
From	10 mm	11	12	3	-40	-40
To	10 mm	11	12	3	90	80

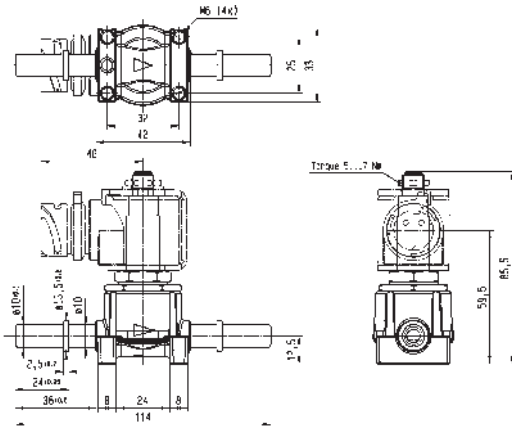

Drawing 8242

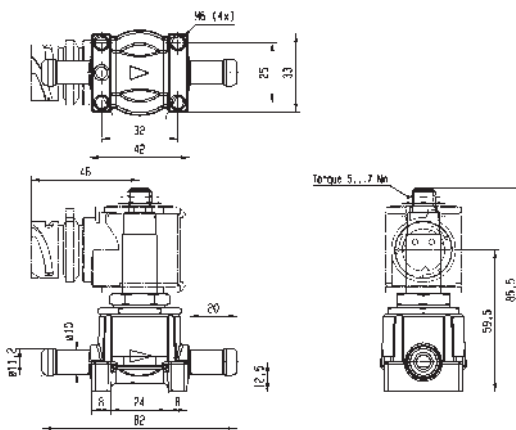

Drawing 8241

2/2

2 WAY
PILOT OPERATED

BRASS
PIPE MOUNTING

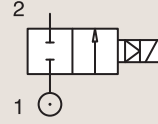

NORMALLY CLOSED

Port size	Orifice Ø mm	Flow factors Kv l/min, KV m³/h, Qn l/min			Operating Pressure Differential Min, Max(MOPD), AC bar, DC bar			Fluid Temp. Min, Max °C		Seat Seal	Parker LUCIFER® Valves			Voltage		Power		Coil Group	Dwg. No.
											Valve Ref.	Housing Ref.	Coil Ref.	AC W	DC W				
1/2" BSP	11	36	2.16	-	0.2	-	3	-40	90	EPDM	321K1523	2168	495294	12 VDC	-	9	13.0	8238	
	11	36	2.16	-	0.2	-	3	-40	90	EPDM	321K1523	2169	495294	24 VDC	-	9	13.0	8238	
	11	36	2.16	-	0.2	-	3	-40	90	EPDM	321K1523	2168	496193	12 VDC	-	9	13.0	8238	
	11	36	2.16	-	0.2	-	3	-40	90	EPDM	321K1523	2169	496193	24 VDC	-	9	13.0	8238	
12.7 mm	11	33	1.98	-	0.2	-	3	-40	90	EPDM	321K1536	2168	495294	12 VDC	-	9	13.0	8282	
	11	33	1.98	-	0.2	-	3	-40	90	EPDM	321K1536	2169	495294	24 VDC	-	9	13.0	8282	
	11	33	1.98	-	0.2	-	3	-40	90	EPDM	321K1536	2168	496193	12 VDC	-	9	13.0	8282	
	11	33	1.98	-	0.2	-	3	-40	90	EPDM	321K1536	2169	496193	24 VDC	-	9	13.0	8282	
15.9 mm	11	36	2.16	-	0.2	-	3	-40	90	EPDM	321K1537	2168	495294	12 VDC	-	9	13.0	8281	
	11	36	2.16	-	0.2	-	3	-40	90	EPDM	321K1537	2169	495294	24 VDC	-	9	13.0	8281	
	11	36	2.16	-	0.2	-	3	-40	90	EPDM	321K1537	2168	496193	12 VDC	-	9	13.0	8281	
	11	36	2.16	-	0.2	-	3	-40	90	EPDM	321K1537	2169	496193	24 VDC	-	9	13.0	8281	



For this page	Port size	Orifice (mm)	Kv (l/min)	MOPD (bar)	Fluid Temp (°C)	Amb Temp (°C)
From	1/2"	11	33	3	-40	-40
To	15.9 mm	11	36	3	90	80

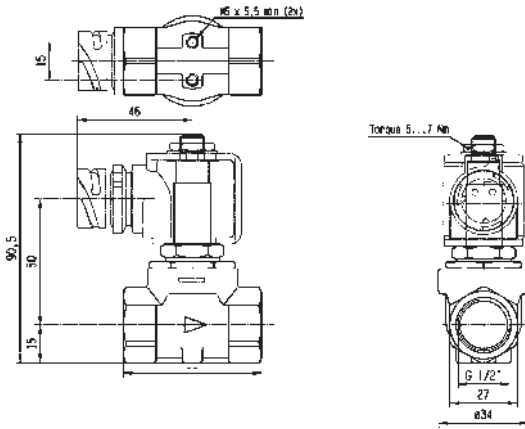

Drawing 8238

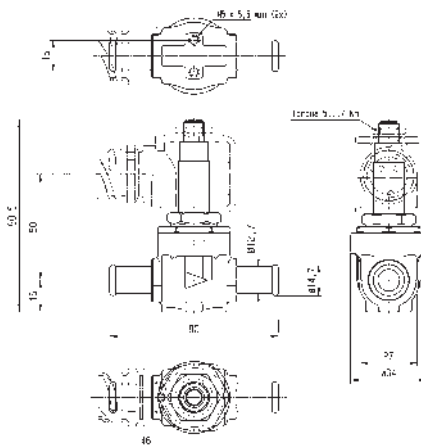

Drawing 8282

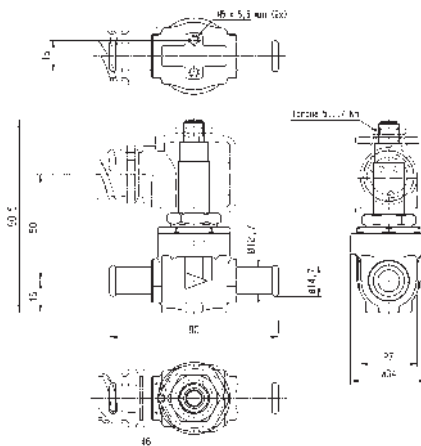

Drawing 8281

2 & 3 WAY VALVES FOR TRANSPORTATION

2 & 3 WAY VALVES FOR TRANSPORTATION



3 WAY



Air

3/2

Actuation	Body	Function	Port Size	Orifice (mm)	Flow Factor Kv(l/min)	MOPD (bar)	Max Fluid Temp. (°C)	Page Parker Valves	Page Parker LUCIFER® Valves
Direct Operated PWM	Brass/Quick Coupling	Normally Closed	1/8"	1.8	0	8	80	-	272

3/2

3 WAY
DIRECT OPERATED PWM



Transportation

BRASS
QUICK COUPLING

NORMALLY CLOSED

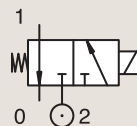

Port size	Orifice Ø		Flow factor Qn l/min	Operating Pressure Differential			Fluid Temp.		Seat Seal	Parker LUCIFER® Valves			Power		Coil Group	Dwg. No.
	1	(2)		Min	Max (MOPD)		Min	Max		Valve Ref.	Housing Ref.	Coil Ref.	AC W	DC W		
	mm			bar	AC bar	DC bar	°C	°C								
1/8"	1.8	1.5	110	0	-	8	-30	80	TPE/PVDF	131K0648 ₁	2161	495294	-	9	13.0	7872
	1.8	1.5	110	0	-	8	-30	80	TPE/PVDF	131K0648 ₁	2161	496193	-	9	13.0	7872

Notes:

1. Valve Pulse Width Modulated



For this page	Port size	Orifice (mm)	Qn (l/min)	MOPD (bar)	Fluid Temp (°C)	Amb Temp (°C)
From	1/8"	1.8	110	8	-30	-30
To	1/8"	1.8	110	8	80	85

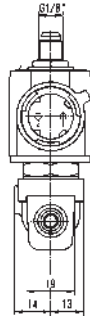
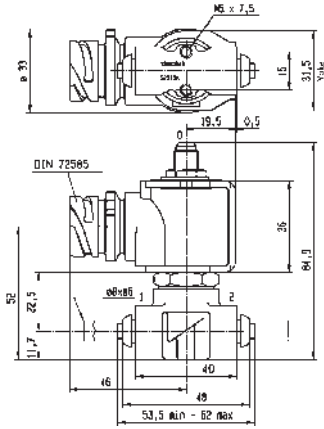

Drawing 7872

5 WAY DISTRIBUTORS FOR PNEUMATIC APPLICATIONS

5 WAY DISTRIBUTORS FOR PNEUMATIC APPLICATIONS



5 WAY PNEUMATIC DISTRIBUTORS (PIPE MOUNTING/SUB-BASE MOUNTING)



5/2

Actuation	Body	Function	Port Size	Orifice (mm)	Qn (l/min)	MOPD (bar)	Max Fluid Temp. (°C)	Page Parker Valves	Page Parker LUCIFER® Valves	
Pilot Operated	Anodized aluminium/ Pipe mounting	Normally Closed	1/8"-1/4"	6	630	10	75	-	276	
			1/4"	6 to 14	2500	40	75	-	276	
			1/2"	14	2500	15	75	-	278	
		Control by Electric Impulse	1/8"-1/4"	6	630	10	75	-	280	
			1/4"	8 to 14	2500	15	75	-	280	
			Anodized aluminium/ Pipe mounting/Poppet	Normally Closed	1/8"	4	400	10	75	-
	Dual Solenoids	1/8"		4	315	10	75	-	282	
	Anodized aluminium/ Sub-base mounting	Normally Closed		1/8"	6	630	10	75	-	284
		Control by Electric Impulse	1/8"	6	630	10	75	-	284	
		Anodized aluminium/ Sub-base mounting/ Poppet	Normally Closed	-	15	5000	10	75	-	286
	1/8"			15	5000	10	75	-	286	
	4 mm			4	400	10	75	-	286	
	Dual Solenoids		4 mm	4	315	10	75	-	288	
			Control by Electric Impulse	-	15	5000	10	75	-	288
			Dual Solenoids	1/8"	6	800	10	75	-	288
Externally Operated	Anodized aluminium/ CETOP/Poppet	Normally Closed	1/4"	8	1400	10	75	-	290	
			1/4"	8	1400	10	100	-	292	
	Anodized aluminium/ Pipe mounting/Poppet	Normally Closed	-	6 to 8	800	10	75	-	292	
			1/8"	6	800	10	75	-	294	
		Control by Electric Impulse	1/8"	6	800	10	75	-	296	
			POM/CETOP/Poppet	Normally Closed	1/8"	7	800	10	75	-

5/2

5 WAY PNEUMATIC DISTRIBUTORS (PIPE MOUNTING/SUB-BASE MOUNTING) PILOT OPERATED



Process



Industrial Equipment

ANODIZED ALUMINIUM PIPE MOUNTING

NORMALLY CLOSED

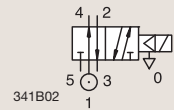
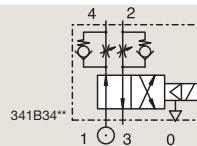

Port size	Orifice Ø	Flow factor	Operating Pressure Differential			Fluid Temp.		Seat Seal	Parker LUCIFER® Valves			IS	Power		Coil Group	Dwg. No.
			Min	Max (MOPD)	Max (MOPD)	Min	Max		Valve Ref.	Housing Ref.	Coil Ref.		AC W	DC W		
BSP	1	Qn l/min	bar	AC bar	DC bar	°C	°C									
1/8" 1/4"	6	630	1	10	10	-10	75	FKM	341B34 ₂	4270	481000		8	8	2.0	3286
	6	630	1	10	10	-10	75	FKM	341B34 ₂	2995	481865		8	9	2.0	3286
	6	630	1	10	10	-10	75	FKM	341B34 ₂	4270	486265		14	14	2.0	3286
	6	630	1	10	10	-10	75	FKM	341B3403	4270	481000		8	8	2.1	3286
	6	630	1	10	10	-10	75	FKM	341B3403	2995	481865		8	9	2.1	3286
	6	560	1	-	10	-10	55	NBR	341B3490	2995	483580.01	*	-	0.5 to 3	7.0/8.0	3561
	6	560	1	-	10	-10	75	NBR	341B3490	-	488660.01	*	-	0.3 to 3	7.0/8.0	3561
1/4"	6	560	1	-	10	-10	75	NBR	341B3490	-	495910	*	-	0.3 to 3	7.0/8.0	3561
	6	630	1	10	10	-25	75	PUR	341B3440	4270	481000		8	8	2.1	3286
	6	630	1	10	10	-25	75	PUR	341B3440	2995	481865		8	9	2.1	3286
	8	640	1	40	40	-10	75	NBR	341B02 ₁	4270	481000		8	8	2.1	8115
	8	640	1	40	40	-10	75	NBR	341B02 ₁	2995	481865		8	9	2.1	8115

Notes:

1. Valve with pilot return pipe on exhaust port
2. With flow regulator



For this page	Port size	Orifice (mm)	Qn (l/min)	MOPD (bar)	Fluid Temp (°C)	Amb Temp (°C)
From	1/8"-1/4"	6	560	10	-25	-25
To	1/4"	8	640	40	75	50

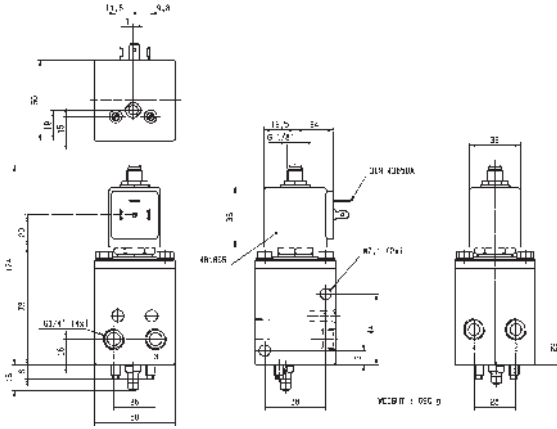

Drawing 3286

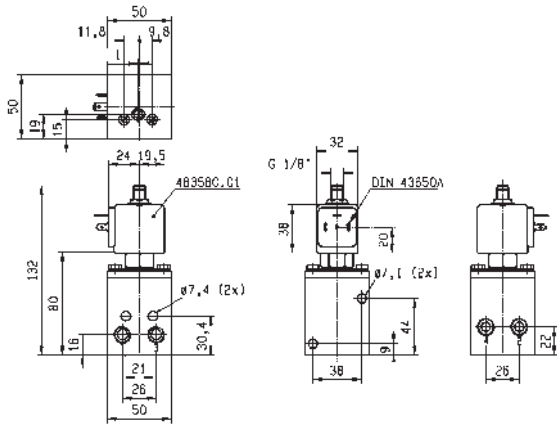

Drawing 3561

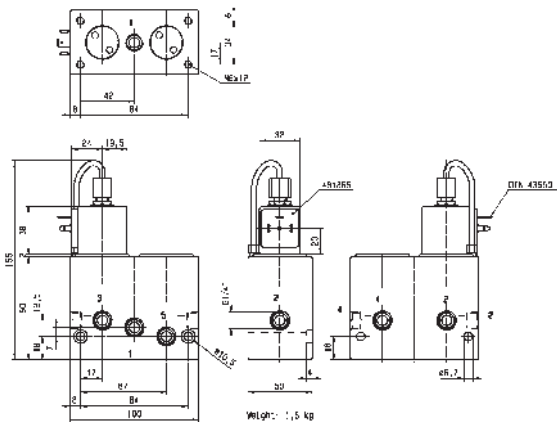

Drawing 8115

5/2

5 WAY PNEUMATIC DISTRIBUTORS (PIPE MOUNTING/SUB-BASE MOUNTING) PILOT OPERATED

ANODIZED ALUMINIUM
PIPE MOUNTING

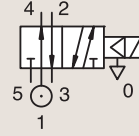

NORMALLY CLOSED

Port size	Orifice Ø 1	Flow factor Qn l/min	Operating Pressure Differential			Fluid Temp.		Seat Seal	Parker LUCIFER® Valves			Power		Coil Group	Dwg. No.
			Min	Max (MOPD)		Min	Max		Valve Ref.	Housing Ref.	Coil Ref.	AC W	DC W		
BSP	mm		bar	AC bar	DC bar	°C	°C								
1/4"	8	1000	1	15	15	-10	75	NBR	E341B01	2995	481865	8	9	2.1	3309
	8	1000	1	15	15	-10	75	NBR	E341B01	4270	485100	8	8	2.1	3309
	14	2500	2	15	15	-10	75	NBR	E341F21	4270	481000	8	8	2.1	3310
1/2"	14	2500	1	15	15	-10	75	NBR	E341B21 ₁	2995	481865	8	9	2.1	3315
	14	2500	1	15	15	-10	75	NBR	E341B21 ₁	-	483371	8	8	2.1	3315

Notes:

1. Valve only compatible with air and neutral gases



For this page	Port size	Orifice (mm)	Qn (l/min)	MOPD (bar)	Fluid Temp (°C)	Amb Temp (°C)
From	1/4"	8	1000	15	-10	-10
To	1/2"	14	2500	15	75	50

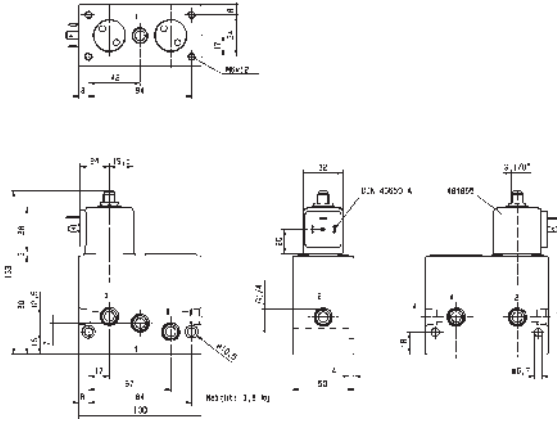

Drawing 3309

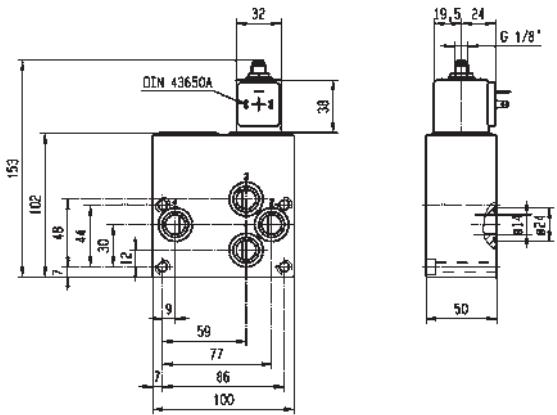

Drawing 3310

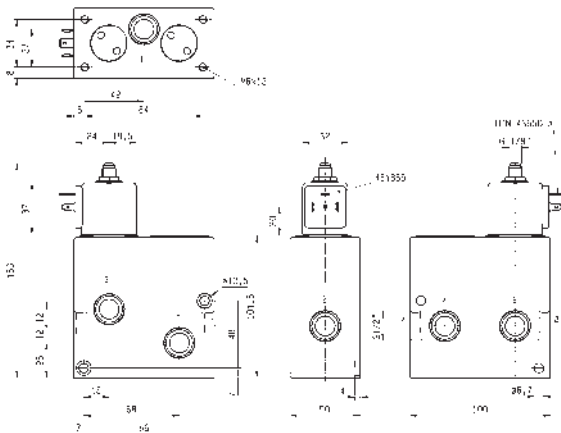

Drawing 3315

5/2

5 WAY PNEUMATIC DISTRIBUTORS (PIPE MOUNTING/SUB-BASE MOUNTING) PILOT OPERATED

ANODIZED ALUMINIUM
PIPE MOUNTING

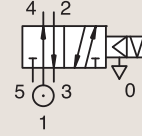

CONTROL BY ELECTRIC IMPULSE

Port size	Orifice Ø	Flow factor	Operating Pressure Differential			Fluid Temp.		Seat Seal	Parker LUCIFER® Valves			Power		Coil Group	Dwg. No.
			Min	Max (MOPD)		Min	Max		Valve Ref.	Housing Ref.	Coil Ref.	AC W	DC W		
BSP	1	Qn l/min	bar	AC bar	DC bar	°C	°C								
1/8"-1/4"	6	630	1	10	-	-10	75	NBR	345B34 ₁₂	4269	484990	11	-	4.0	3286
	6	630	1	-	10	-10	75	NBR	345B34 ₁₂	4269	485400	-	13	4.0	3286
1/4"	8	1000	1	15	-	-10	75	NBR	345B04	4269	484990	11	-	4.0	3309
	8	1000	1	-	15	-10	75	NBR	345B04	4269	485400	-	13	4.0	3309
	14	2500	1	15	-	-10	75	NBR	345B24	4269	484990	11	-	4.0	3315
	14	2500	1	-	15	-10	75	NBR	345B24	4269	485400	-	13	4.0	3315

Notes:

- 1. Valve only compatible with air and neutral gases
- 2. With flow regulator



For this page	Port size	Orifice (mm)	Qn (l/min)	MOPD (bar)	Fluid Temp (°C)	Amb Temp (°C)
From	1/8"-1/4"	6	630	10	-10	-10
To	1/4"	14	2500	15	75	50

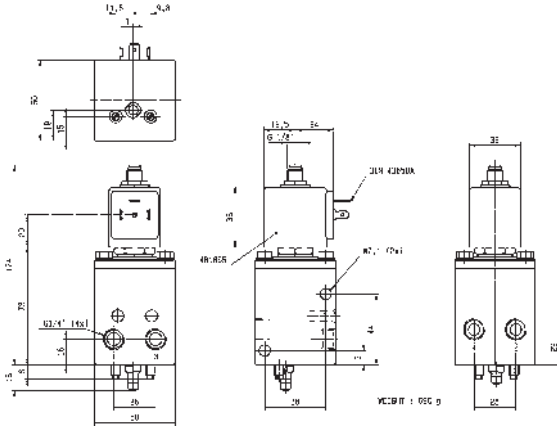

Drawing 3286

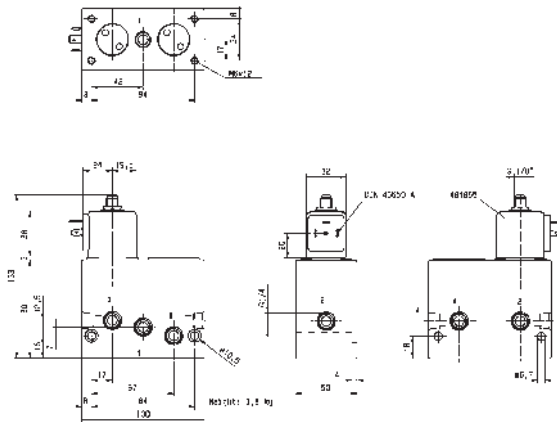

Drawing 3309

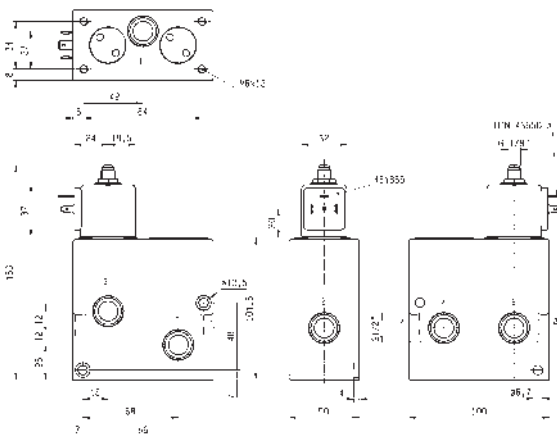

Drawing 3315

5/2

5 WAY PNEUMATIC DISTRIBUTORS (PIPE MOUNTING/SUB-BASE MOUNTING) PILOT OPERATED

ANODIZED ALUMINIUM PIPE MOUNTING

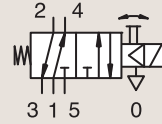

NORMALLY CLOSED

Port size	Orifice Ø	Flow factor	Operating Pressure Differential		Fluid Temp.		Seat Seal	Parker LUCIFER® Valves			Power		Coil Group	Dwg. No.	
			Min	Max (MOPD)	Min	Max		Valve Ref.	Housing Ref.	Coil Ref.	AC W	DC W			
BSP	1	Qn l/min	bar	AC bar	DC bar	°C	°C								
1/8"	4	400	1	10	10	-10	75	NBR	341L9101 ₁	-	482605	4	5	1.1	3894
	4	400	1	10	10	-10	75	NBR	341L9101 ₁	-	482606	2	2.5	1.1	3894
	4	400	1	10	10	-10	75	NBR	341L9101 ₁	8993	488980	2	2.5	1.1	3894
	4	400	1	10	10	-10	75	NBR	341L9101 ₁	8993	495865	2	2.5	1.1	3894

Notes:

1. With manual override

ANODIZED ALUMINIUM PIPE MOUNTING

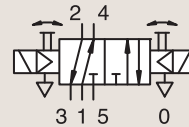

DUAL SOLENOIDS

Port size	Orifice Ø	Flow factor	Operating Pressure Differential		Fluid Temp.		Seat Seal	Parker LUCIFER® Valves			Power		Coil Group	Dwg. No.	
			Min	Max (MOPD)	Min	Max		Valve Ref.	Housing Ref.	Coil Ref.	AC W	DC W			
BSP	1	Qn l/min	bar	AC bar	DC bar	°C	°C								
1/8"	4	315	2	10	10	-10	75	NBR	347L9101 ₁	-	482605	4	5	1.1	3896
	4	315	2	10	10	-10	75	NBR	347L9101 ₁	-	482606	2	2.5	1.1	3896
	4	315	2	10	10	-10	75	NBR	347L9101 ₁	8993	488980	2	2.5	1.1	3896
	4	315	2	10	10	-10	75	NBR	347L9101 ₁	8993	495865	2	2.5	1.1	3896

Notes:

1. With manual override

5 WAY VALVES



For this page	Port size	Orifice (mm)	Qn (l/min)	MOPD (bar)	Fluid Temp (°C)	Amb Temp (°C)
From	1/8"	4	315	10	-10	-10
To	1/8"	4	400	10	75	50

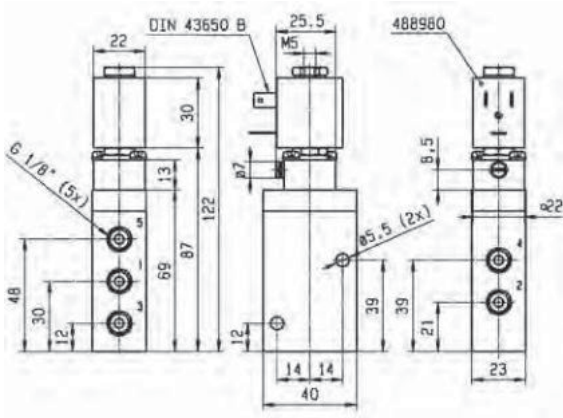

Drawing 3894

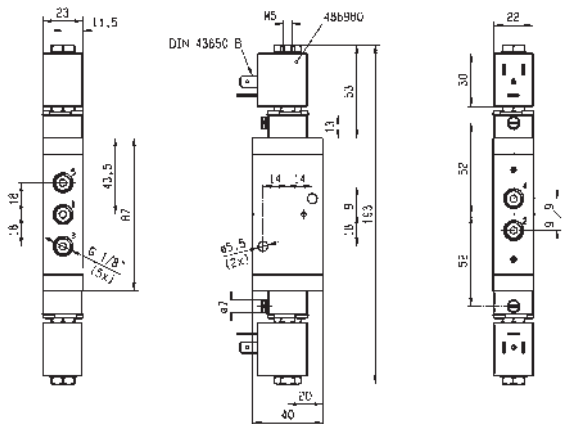

Drawing 3896

5/2

5 WAY PNEUMATIC DISTRIBUTORS (PIPE MOUNTING/SUB-BASE MOUNTING) PILOT OPERATED

ANODIZED ALUMINIUM SUB-BASE MOUNTING

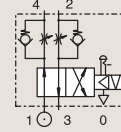

NORMALLY CLOSED

Port size	Orifice Ø 1 mm	Flow factor Qn l/min	Operating Pressure Differential		Fluid Temp.		Seat Seal	Parker LUCIFER® Valves			Power		Coil Group	Dwg. No.	
			Min	Max (MOPD)	Min	Max		Valve Ref.	Housing Ref.	Coil Ref.	AC	DC			
			bar	AC bar	DC bar	°C					°C	W			W
SB	6	630	1	10	10	-10	75	FKM	341F34 ₁	2995	481865	8	9	2.1	3287
	6	630	1	10	10	-10	75	FKM	341F34 ₁	4270	481000	8	8	2.1	3287
	6	630	1	10	10	-10	75	FKM	341F3403	2995	481865	8	9	2.1	3287
	6	630	1	10	10	-10	75	FKM	341F3403	4270	481000	8	8	2.1	3287
	6	630	1	10	10	-25	75	NBR	341F3440	2995	481865	8	9	2.1	3287

Notes:

1. With flow regulator

ANODIZED ALUMINIUM SUB-BASE MOUNTING

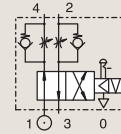

CONTROL BY ELECTRIC IMPULSE

Port size	Orifice Ø 1 mm	Flow factor Qn l/min	Operating Pressure Differential		Fluid Temp.		Seat Seal	Parker LUCIFER® Valves			Power		Coil Group	Dwg. No.	
			Min	Max (MOPD)	Min	Max		Valve Ref.	Housing Ref.	Coil Ref.	AC	DC			
			bar	AC bar	DC bar	°C					°C	W			W
SB	6	630	1	10	-	-10	75	FKM	345F34 ₁	4269	484990	11	-	4.0	3287
	6	630	1	-	10	-10	75	FKM	345F34 ₁	4269	485400	-	13	4.0	3287

Notes:

1. With flow regulator



For this page	Port size	Orifice (mm)	Qn (l/min)	MOPD (bar)	Fluid Temp (°C)	Amb Temp (°C)
From	SB	6	630	10	-25	-25
To	SB	6	630	10	75	50

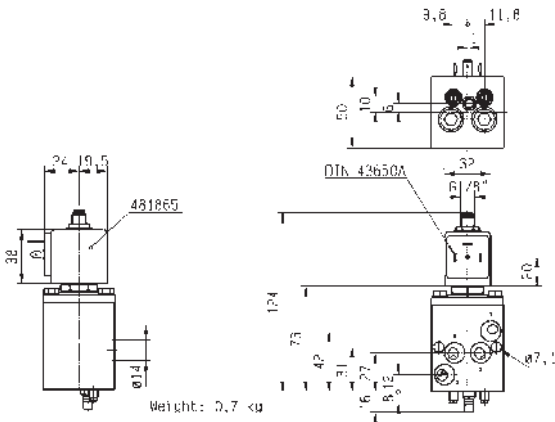

Drawing 3287

5/2

5 WAY PNEUMATIC DISTRIBUTORS (PIPE MOUNTING/SUB-BASE MOUNTING) PILOT OPERATED

ANODIZED ALUMINIUM SUB-BASE MOUNTING ISO

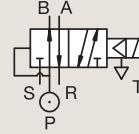

NORMALLY CLOSED

Port size	Orifice Ø 1 mm	Flow factor Qn l/min	Operating Pressure Differential			Fluid Temp.		Seat Seal	Parker LUCIFER® Valves			Power		Coil Group	Dwg. No.	
			Min bar	Max (MOPD)		Min °C	Max °C		Valve Ref.	Housing Ref.	Coil Ref.	IS	AC W			DC W
				AC bar	DC bar											
SB	15	5000	0.5	10	10	-10	75	FKM	E341L21 ₁	2995	481865	8	9	2.1/3.0	3299	
	15	5000	0.5	10	10	-10	75	FKM	E341L21 ₁	-	495905	8	8	2.1/3.0	3299	
	15	5000	0.5	-	10	-10	55	NBR	341L2190 ₁	2995	483580.01	*	-	0.5 to 3	7.0/8.0	8271
	15	5000	0.5	-	10	-10	75	NBR	341L2190 ₁	-	488660.01	*	-	0.3 to 3	7.0/8.0	8271
	15	5000	0.5	-	10	-10	75	NBR	341L2190 ₁	-	495910	*	-	0.3 to 3	7.0/8.0	8271

Notes:

1. Valve with manual override

ANODIZED ALUMINIUM SUB-BASE MOUNTING

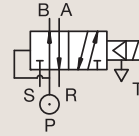

NORMALLY CLOSED

Port size	Orifice Ø 1 mm	Flow factor Qn l/min	Operating Pressure Differential			Fluid Temp.		Seat Seal	Parker LUCIFER® Valves			Power		Coil Group	Dwg. No.	
			Min bar	Max (MOPD)		Min °C	Max °C		Valve Ref.	Housing Ref.	Coil Ref.	IS	AC W			DC W
				AC bar	DC bar											
SB	4	400	1	10	10	-10	75	NBR	341L9201 ₁	-	482605	-	5	1.1	3895	
	4	400	1	10	10	-10	75	NBR	341L9201 ₁	-	482606	2	2.5	1.1	3895	
	4	400	1	10	10	-10	75	NBR	341L9201 ₁	8993	488980	2	2.5	1.1	3895	
	4	400	1	10	10	-10	75	NBR	341L9201 ₁	8993	495865	2	2.5	1.1	3895	

Notes:

1. Valve with manual override



For this page	Port size	Orifice (mm)	Qn (l/min)	MOPD (bar)	Fluid Temp (°C)	Amb Temp (°C)
From	SB	4	400	10	-10	-10
To	SB	15	5000	10	75	50

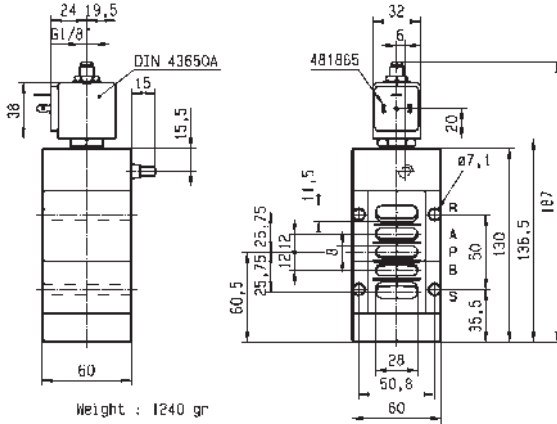

Drawing 3299

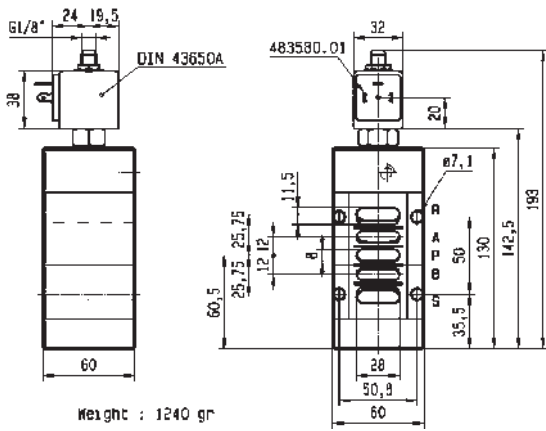

Drawing 8271

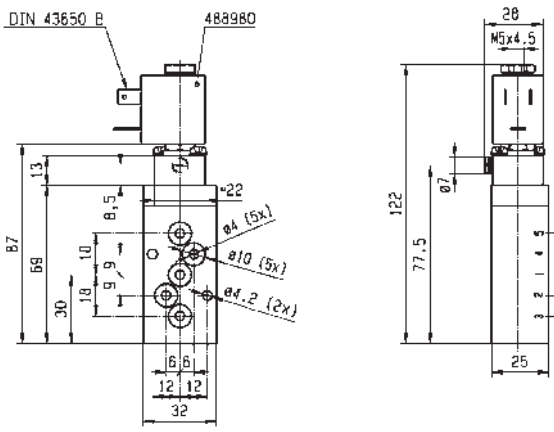

Drawing 3895

5/2

5 WAY PNEUMATIC DISTRIBUTORS (PIPE MOUNTING/SUB-BASE MOUNTING) PILOT OPERATED

ANODIZED ALUMINIUM SUB-BASE MOUNTING

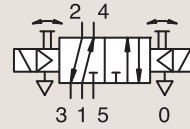

DUAL SOLENOIDS

Port size	Orifice Ø 1 mm	Flow factor Qn l/min	Operating Pressure Differential			Fluid Temp.		Seat Seal	Parker LUCIFER® Valves			Power		Coil Group	Dwg. No.
			Min bar	Max (MOPD)		Min °C	Max °C		Valve Ref.	Housing Ref.	Coil Ref.	AC W	DC W		
				AC bar	DC bar										
SB	4	315	2	10	10	-10	75	NBR	347L9201	-	482605	-	5	1.1	3897
	4	315	2	10	10	-10	75	NBR	347L9201	-	482606	2	2.5	1.1	3897
	4	315	2	10	10	-10	75	NBR	347L9201	8993	488980	2	2.5	1.1	3897
	4	315	2	10	10	-10	75	NBR	347L9201	8993	495865	2	2.5	1.1	3897

ANODIZED ALUMINIUM SUB-BASE MOUNTING

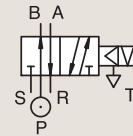

CONTROL BY ELECTRIC IMPULSE

Port size	Orifice Ø 1 mm	Flow factor Qn l/min	Operating Pressure Differential			Fluid Temp.		Seat Seal	Parker LUCIFER® Valves			Power		Coil Group	Dwg. No.
			Min bar	Max (MOPD)		Min °C	Max °C		Valve Ref.	Housing Ref.	Coil Ref.	AC W	DC W		
				AC bar	DC bar										
SB	15	5000	0.5	10	-	-10	75	NBR	345L21	4269	484990	11	-	4.0	3299
	15	5000	0.5	-	10	-10	75	NBR	345L21	4269	485400	-	13	4.0	3299

ANODIZED ALUMINIUM CETOP

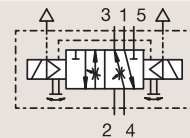

DUAL SOLENOIDS

Port size	Orifice Ø 1 mm	Flow factor Qn l/min	Operating Pressure Differential			Fluid Temp.		Seat Seal	Parker LUCIFER® Valves			Power		Coil Group	Dwg. No.
			Min bar	Max (MOPD)		Min °C	Max °C		Valve Ref.	Housing Ref.	Coil Ref.	AC W	DC W		
				AC bar	DC bar										
BSP 1/8"	6	800	1	10	10	-10	75	NBR	347L04	8993	488980	2	2.5	1.1	3694



For this page	Port size	Orifice (mm)	Qn (l/min)	MOPD (bar)	Fluid Temp (°C)	Amb Temp (°C)
From	SB	4	315	10	-10	-10
To	4 mm	15	5000	10	75	50

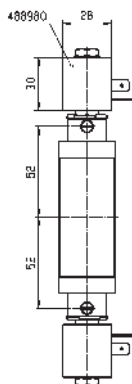
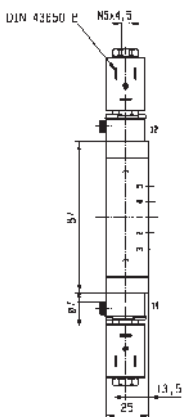
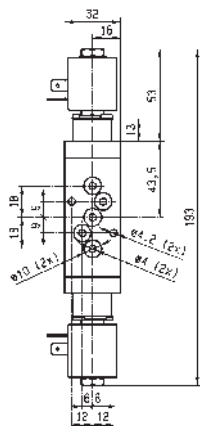

Drawing 3897

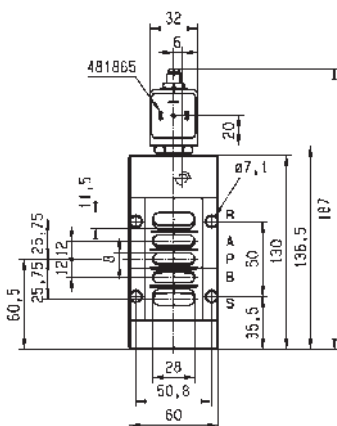
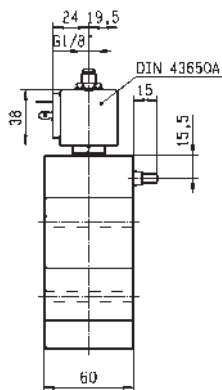

Weight : 1240 gr



Drawing 3299

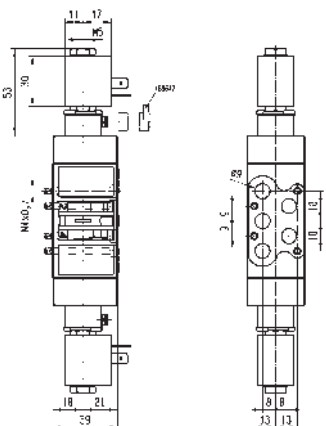
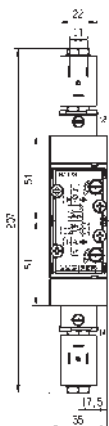

Drawing 3694

5/2

5 WAY PNEUMATIC DISTRIBUTORS (PIPE MOUNTING/SUB-BASE MOUNTING) PILOT OPERATED

ANODIZED ALUMINIUM
PIPE MOUNTING

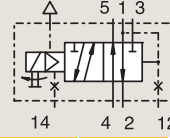

NORMALLY CLOSED

Port size	Orifice Ø	Flow factor	Operating Pressure Differential		Fluid Temp.		Seat Seal	Parker LUCIFER® Valves			Power		Coil Group	Dwg. No.	
			Min	Max (MOPD)	Min	Max		Valve Ref.	Housing Ref.	Coil Ref.	AC W	DC W			
BSP	1	Qn l/min	bar	AC bar	DC bar	°C	°C								
1/4"	8	1400	1	10	10	-10	75	NBR	341L11	-	482605	4	5	1.1	3434
	8	1400	1	10	10	-10	75	NBR	341L11	-	482606	2	2.5	1.1	3434
	8	1400	1	10	10	-10	75	NBR	341L11	8993	488980	2	2.5	1.1	3434
	8	1400	1	10	10	-10	75	NBR	341L11	8993	495865	2	2.5	1.1	3434
	8	1400	1	10	10	-10	75	NBR	E341L1130	2995	481865	8	9	2.1/3.0	3539
	8	1400	1	10	10	-10	75	NBR	E341L1130	-	483371	8	8	2.1/3.0	3539
1/4" NPT	8	1400	1	10	10	-10	75	FKM	U341L1130	2995	481865	8	9	2.1	8297
	8	1400	1	10	10	-10	75	FKM	U341L1130	2995	491514	11	12	2.1	8297



For this page	Port size	Orifice (mm)	Qn (l/min)	MOPD (bar)	Fluid Temp (°C)	Amb Temp (°C)
From	1/4"	8	1400	10	-10	-10
To	1/4"	8	1400	10	75	50

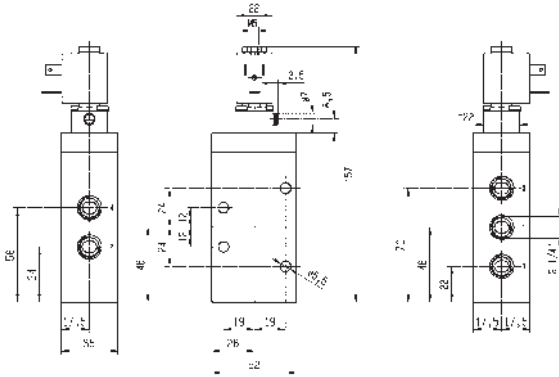

Drawing 3434

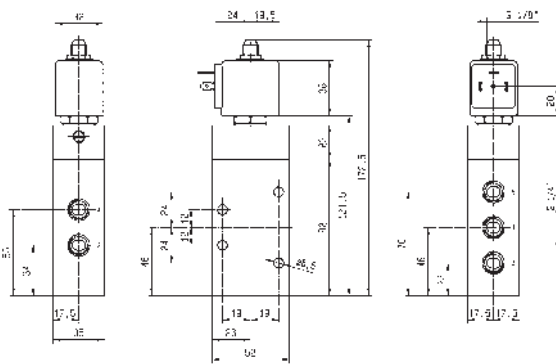

Drawing 3539

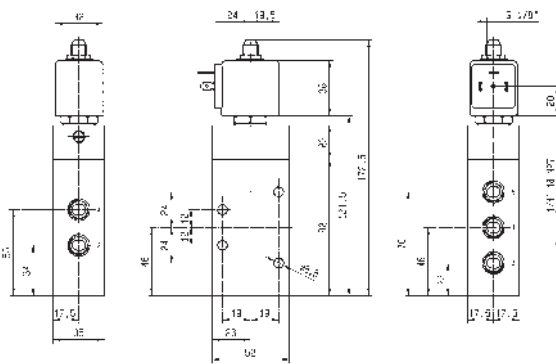

Drawing 8297

5/2

5 WAY PNEUMATIC DISTRIBUTORS (PIPE MOUNTING/SUB-BASE MOUNTING) PILOT OPERATED

ANODIZED ALUMINIUM PIPE MOUNTING

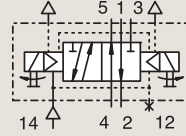

DUAL SOLENOIDS

Port size	Orifice Ø	Flow factor	Operating Pressure Differential			Fluid Temp.		Seat Seal	Parker LUCIFER® Valves			Power		Coil Group	Dwg. No.
			Min	Max (MOPD)		Min	Max		Valve Ref.	Housing Ref.	Coil Ref.	AC W	DC W		
BSP	1	Qn l/min	bar	AC bar	DC bar	°C	°C								
1/4"	8	1400	1	10	10	-10	75	NBR	347L11 ₁	-	482605	4	5	1.1	3461
	8	1400	1	10	10	-10	75	NBR	347L11 ₁	-	482606	2	2.5	1.1	3461
	8	1400	1	10	10	-10	75	NBR	347L11 ₁	8993	488980	2	2.5	1.1	3461
	8	1400	1	10	10	-10	75	NBR	347L11 ₁	8993	495865	2	2.5	1.1	3461
	8	1400	2	10	10	-10	100	FKM	E347L1130 ₁	2995	481865	8	9	2.1/3.0	3541
	8	1400	2	10	10	-10	100	FKM	E347L1130 ₁	4270	481000	8	8	2.1/3.0	3541

Notes:

1. With manual override

POM CETOP

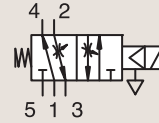

NORMALLY CLOSED

Port size	Orifice Ø	Flow factor	Operating Pressure Differential			Fluid Temp.		Seat Seal	Parker LUCIFER® Valves			Power		Coil Group	Dwg. No.
			Min	Max (MOPD)		Min	Max		Valve Ref.	Housing Ref.	Coil Ref.	AC W	DC W		
	1	Qn l/min	bar	AC bar	DC bar	°C	°C								
-	6	800	1	10	10	-10	75	FKM	E341L02	2995	481865	8	9	2.1/3.0	3513
-	6	800	1	10	10	-10	75	FKM	E341L02	4270	481000	8	8	2.1/3.0	3513



For this page	Port size	Orifice (mm)	Qn (l/min)	MOPD (bar)	Fluid Temp (°C)	Amb Temp (°C)
From	1/4"	6	800	10	-10	-10
To	1/4"	8	1400	10	100	50

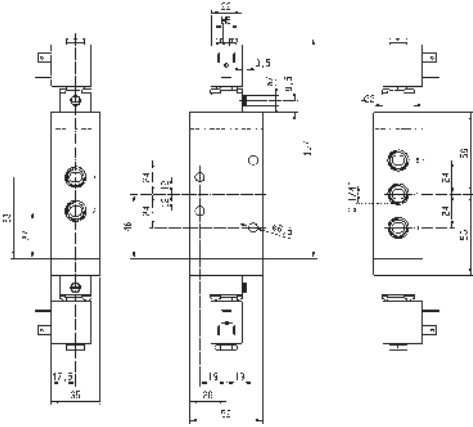

Drawing 3461

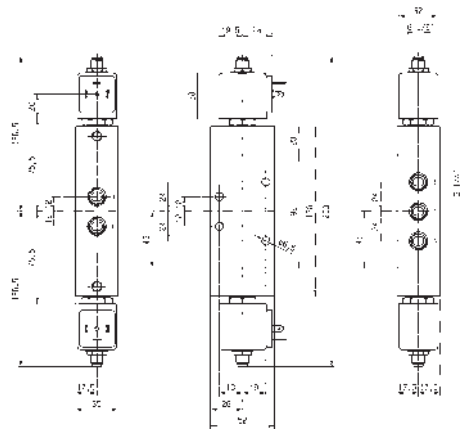

Drawing 3541

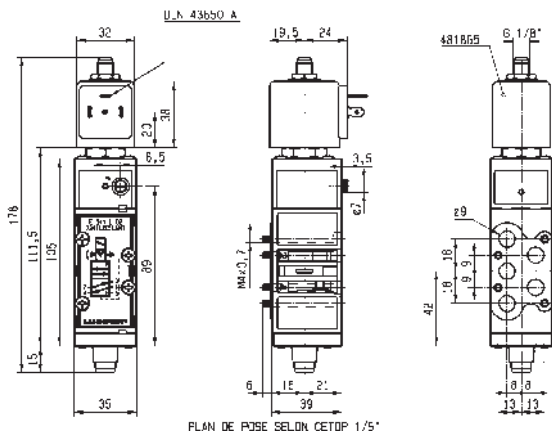

Drawing 3513

5/2

5 WAY PNEUMATIC DISTRIBUTORS (PIPE MOUNTING/SUB-BASE MOUNTING) PILOT OPERATED

POM
CETOP

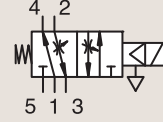

NORMALLY CLOSED

Port size BSP	Orifice Ø 1 mm	Flow factor Qn l/min	Operating Pressure Differential			Fluid Temp.		Seat Seal	Parker LUCIFER® Valves			Power		Coil Group	Dwg. No.
			Min bar	Max (MOPD)		Min °C	Max °C		Valve Ref.	Housing Ref.	Coil Ref.	AC W	DC W		
				AC bar	DC bar										
-	8	800	1	10	10	-10	75	FKM	341L04 ₁	-	482605	4	5	1.1	3437
	8	800	1	10	10	-10	75	FKM	341L04 ₁	-	482606	2	2.5	1.1	3437
	8	800	1	10	10	-10	75	FKM	341L04 ₁	8993	488980	2	2.5	1.1	3437
	8	800	1	10	10	-10	75	FKM	341L04 ₁	8993	495865	2	2.5	1.1	3437
1/8"	6	800	1	-	10	-10	75	NBR	341L0197	2995	482740	-	1.6	6.0/8.0	8021
	6	800	1	10	10	-10	75	NBR	341L0197	-	495900	2.5	2	6.0/8.0	8021
	6	800	1	-	10	-10	75	NBR	341L0197	-	495910	-	0.3 to 3	6.0/8.0	8021
	6	800	1	-	10	-10	75	NBR	341L0197	2995	496125	-	1.6	6.0/8.0	8021
	6	800	1	10	10	-10	75	NBR	341L05 ₂	-	482605	4	5	1.1	3430
	6	800	1	10	10	-10	75	NBR	341L05 ₂	-	482606	2	2.5	1.1	3430
	6	800	1	10	10	-10	75	NBR	341L05 ₂	8993	488980	2	2.5	1.1	3430
	6	800	1	10	10	-10	75	NBR	341L05 ₂	8993	495865	2	2.5	1.1	3430
	6	800	1	10	-	-10	75	FKM	E341L01 ₁	2995	482722	10	-	2.1/3.0	3255
	6	800	1	10	10	-10	75	FKM	E341L01 ₁	-	483371	8	8	2.1/3.0	3255
6	800	1	10	10	-10	75	FKM	E341L01 ₁	2995.33	491514	11	12	2.1/3.0	3255	

Notes:

- 1. Manual override and flow regulating screws standard
- 2. With manual override

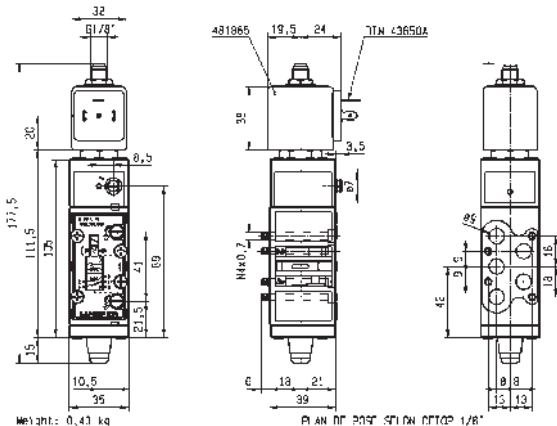

Drawing 3255



For this page	Port size	Orifice (mm)	Qn (l/min)	MOPD (bar)	Fluid Temp (°C)	Amb Temp (°C)
From	1/8"	6	800	10	-10	-20
To	1/8"	8	800	10	75	50

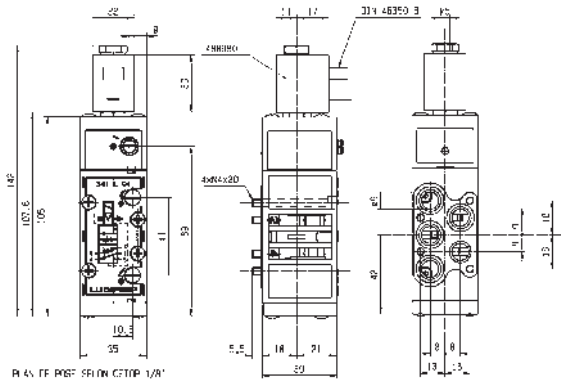

PLAN DE POSE SELON DETAIL 1/8"



Drawing 3437

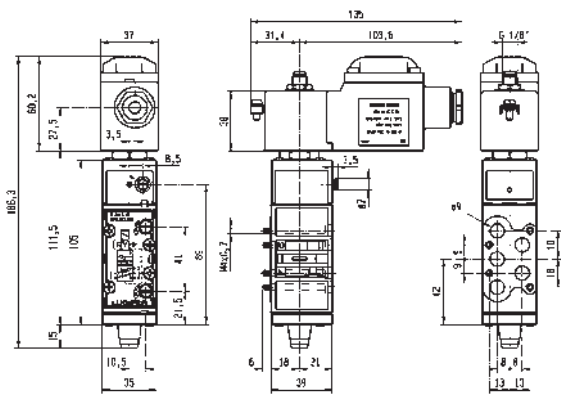

Drawing 8021

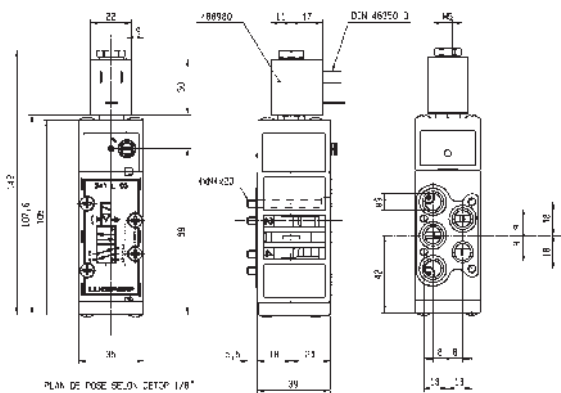

PLAN DE POSE SELON DETAIL 1/8"



Drawing 3430

5/2

5 WAY PNEUMATIC DISTRIBUTORS (PIPE MOUNTING/SUB-BASE MOUNTING) PILOT OPERATED

POM
CETOP

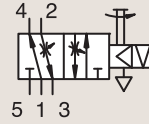

CONTROL BY ELECTRIC IMPULSE

Port size	Orifice Ø	Flow factor	Operating Pressure Differential			Fluid Temp.		Seat Seal	Valve Ref.	Parker LUCIFER® Valves			Power		Coil Group	Dwg. No.
			Min	Max (MOPD)		Min	Max			Housing Ref.	Coil Ref.	AC W	DC W			
BSP	mm	Qn l/min	bar	AC bar	DC bar	°C	°C									
1/8"	6	800	1	-	10	-10	75	FKM	345L01 ₁	4269	485400	-	13	4.0	3255	

Notes:

1. Manual override and flow regulating screws standard



For this page	Port size	Orifice (mm)	Qn (l/min)	MOPD (bar)	Fluid Temp (°C)	Amb Temp (°C)
From	1/8"	6	800	10	-10	-10
To	1/8"	6	800	10	75	50

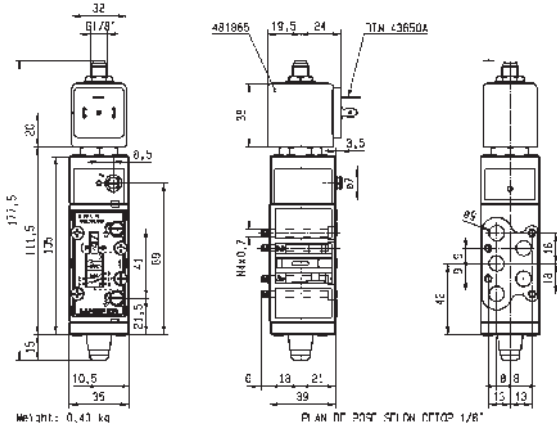

Drawing 3255

5/2

5 WAY PNEUMATIC DISTRIBUTORS (PIPE MOUNTING/SUB-BASE MOUNTING) EXTERNALLY OPERATED



Process



Industrial Equipment

POM
SUB-BASE MOUNTING

NORMALLY CLOSED

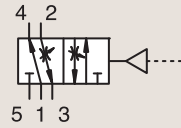

Port size	Orifice Ø 1 mm	Flow factor Qn l/min	Operating Pressure Differential			Fluid Temp.		Seat Seal FKM/ NBR	Parker LUCIFER® Valves			Power		Coil Group	Dwg. No.
			Min bar	Max (MOPD) AC bar	DC bar	Min °C	Max °C		Valve Ref.	Housing Ref.	Coil Ref.	AC W	DC W		
SB	7	800	1	10	10	-10	75	541L01	-	-	-	-	-	-	3254



For this page	Port size	Orifice (mm)	Qn (l/min)	MOPD (bar)	Fluid Temp (°C)	Amb Temp (°C)
From	1/8"	7	800	10	-10	-10
To	1/8"	7	800	10	75	50

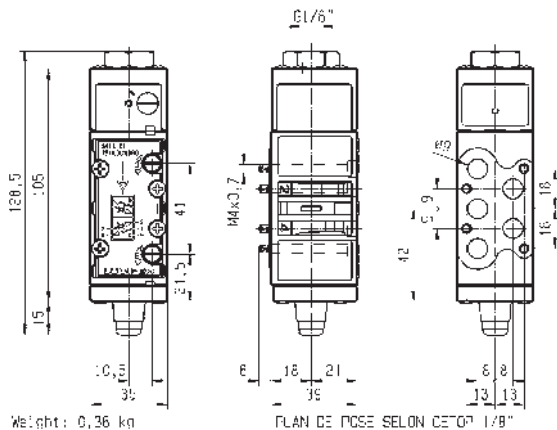

Weight: 0,36 kg

Drawing 3254

3 & 5 WAY PNEUMATIC DISTRIBUTORS FOR ACTUATION CONTROL



3 & 5 WAY PNEUMATIC VALVES FOR ACTUATOR CONTROL (PIPE MOUNTING)



3/2
5/2

Actuation	Body	Function	Port Size	Orifice (mm)	Qn (l/min)	MOPD (bar)	Max Fluid Temp. (°C)	Page Parker Valves	Page Parker LUCIFER® Valves		
Direct Operated	Brass/Pipe mounting	Normally Closed	1/8"	1.2 to 1.5	70	10	75	-	302		
			1/8"-1/4"	2.5	220	7	75	-	302		
			1/4"	1 to 4.5	500	16	120	-	302		
		Normally Open	1/4"	2.5	220	7	75	-	308		
		Universal	1/4"	6	680	10	75	-	308		
			Control by Electric Impulse	1/4"	2.5	220	7	100	-	310	
	Brass/Sub-base mounting	Normally Closed	5 mm	2.5	180	2	75	-	312		
		Universal	1/8"	2	140	7	120	-	312		
		Universal	1/4"	6	680	10	80	-	314		
	Pilot Operated	Anodized aluminium/ Pipe mounting/Spool	Normally Closed	1/8"	4 to 15	600	10	80	-	316	
1/4"				7 to 8	1400	10	80	-	318		
1/2"				12	3000	10	50	-	322		
Dual Solenoids			1/8"	4	400	10	80	-	324		
			1/4"	7 to 8	1400	10	80	-	326		
			1/2"	12	3000	10	50	-	328		
				Control by Electric Impulse	1/8"	4	600	10	80	-	328
Manual Reset			Brass/Pipe mounting	Universal	1/4"	6	680	10	65	-	330

3/2

3 & 5 WAY PNEUMATIC VALVES FOR ACTUATOR CONTROL (PIPE MOUNTING) DIRECT OPERATED



Commercial Equipment



Industrial Equipment



Process

BRASS PIPE MOUNTING

NORMALLY CLOSED

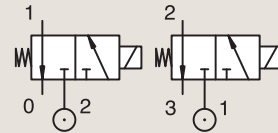

Port size	Orifice Ø	Flow factor	Operating Pressure Differential		Fluid Temp.		Seat Seal	Parker LUCIFER® Valves			ATEX Zone	Protection Mode	Power		Coil Group	Dwg. No.	
			Min	Max (MOPD)	Min	Max		Valve Ref.	Housing Ref.	Coil Ref.			AC W	DC W			
BSP	mm	Qn l/min	bar	AC bar	DC bar	°C	°C										
1/8"	1.2	50	0	10	10	-10	75	FKM	131M15	8993	488980	-	-	2	2.5	1.1	3382
	1.5	70	0	7	7	-10	75	FKM	131M14	8993	488980	-	-	2	2.5	1.1	3382
1/8"-1/4"	2.5	220	0	7	7	-40	75	PUR	E131K0358	2995	481865	-	-	8	9	2.1	3510
	2.5	220	0	7	7	-40	75	PUR	E131K0358	4270	481000	-	-	8	8	2.1	3510
1/4"	1	36	0	-	10	-10	55	FKM	131K0490	2995	483580.01	0-20	Ex ia IIC T6	-	0.5 to 3	7.0/8.0	7058
	1	36	0	-	10	-10	75	FKM	131K0490	-	488660.01	0-20	Ex ia IIC T6	-	0.3 to 3	7.0/8.0	7058
	1	36	0	-	10	-10	75	FKM	131K0490	-	495910	0-20	Ex ia IIC T4 to T6	-	0.3 to 3	7.0/8.0	7058

Notes:

1. With manual override



For this page	Port size	Orifice (mm)	Qn (l/min)	MOPD (bar)	Fluid Temp (°C)	Amb Temp (°C)
From	1/8"	1	36	7	-40	-40
To	1/4"	2.5	220	10	75	50

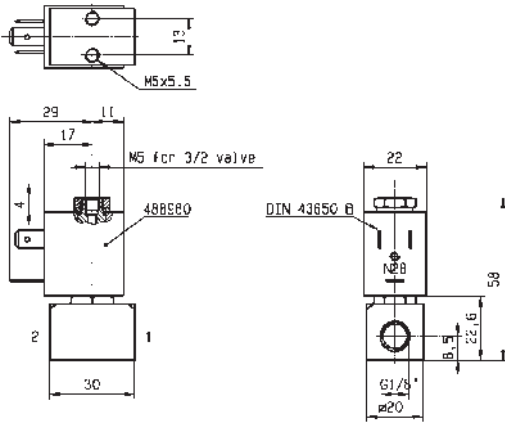

Drawing 3382

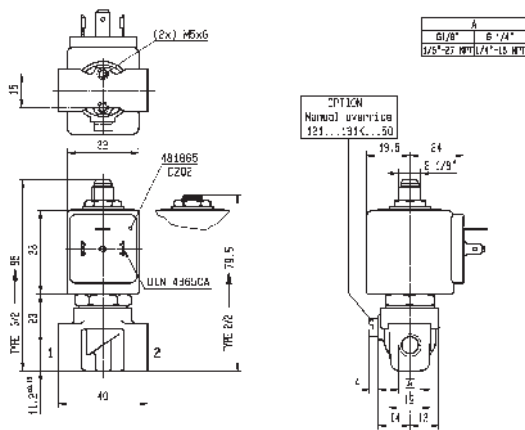

Drawing 3510

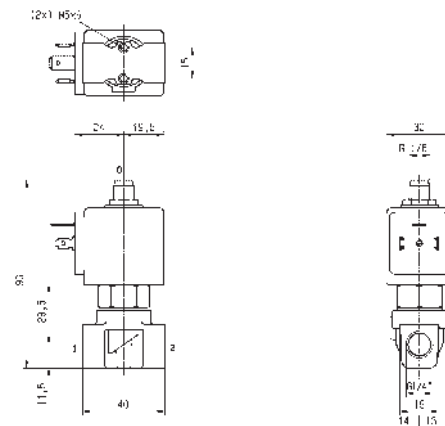

Drawing 7058

3/2

3 & 5 WAY PNEUMATIC VALVES FOR ACTUATOR CONTROL (PIPE MOUNTING) DIRECT OPERATED

BRASS

PIPE MOUNTING

NORMALLY CLOSED

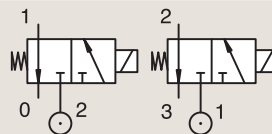

Port size	Orifice Ø	Flow factor	Operating Pressure Differential			Fluid Temp.		Seat Seal	Parker LUCIFER® Valves			ATEX Zone	Protection Mode		Power		Coil Group	Dwg. No.
			Min	Max (MOPD)	DC bar	Min	Max		Valve Ref.	Housing Ref.	Coil Ref.		AC W	DC W				
BSP	1	Qn l/min	bar	AC bar	DC bar	°C	°C											
1/4"	1.5	80	0	-	7	-20	75	PUR	131K0497	2995	482740	-	-	-	1.6	6.0/8.0	8023	
	1.5	80	0	7	7	-20	75	PUR	131K0497	-	495900	1-21	Ex db mb IIC T4 to T6	2.5	2	6.0/8.0	8023	
	1.5	80	0	-	7	-20	75	PUR	131K0497	-	495910	0-20	Ex ia IIC T4 to T6	-	0.3 to 3	6.0/8.0	8023	
	1.5	80	0	-	7	-20	75	PUR	131K0497	2995	496125	2-22	Ex nAc nCc IIC T5/T6	-	1.6	6.0/8.0	8023	
	1.5	80	0	16	16	-10	100	FKM	E131K04	2995	481865	-	-	8	9	2.0	3510	
	1.5	80	0	16	16	-10	120	FKM	E131K04	4270	481000	-	-	8	8	2.0	3510	
	1.5	80	0	16	16	-10	120	FKM	E131K04	4270	486265	-	-	14	14	2.0	3510	
	1.5	80	0	15	15	-10	100	FKM	E131K0450 ₁	2995	481865	-	-	8	9	2.1	3510	
	1.5	80	0	15	15	-10	120	FKM	E131K0450 ₁	4270	481000	-	-	8	8	2.1	3510	
	2	140	0	10	10	-10	100	FKM	E131K06	2995	481865	-	-	8	9	2.0	8119	
	2	140	0	10	10	-10	120	FKM	E131K06	4270	481000	-	-	8	8	2.0	8119	
	2	140	0	10	10	-10	120	FKM	E131K06	4270	486265	-	-	14	14	2.0	8119	
	2	140	0	10	10	-10	100	FKM	E131K0650 ₁	2995	481865	-	-	8	9	2.1	3510	
	2	140	0	10	10	-10	120	FKM	E131K0650 ₁	4270	481000	-	-	8	8	2.1	3510	

Notes:

1. With manual override



For this page	Port size	Orifice (mm)	Qn (l/min)	MOPD (bar)	Fluid Temp (°C)	Amb Temp (°C)
From	1/4"	1.5	80	7	-20	-20
To	1/4"	2	140	16	120	50

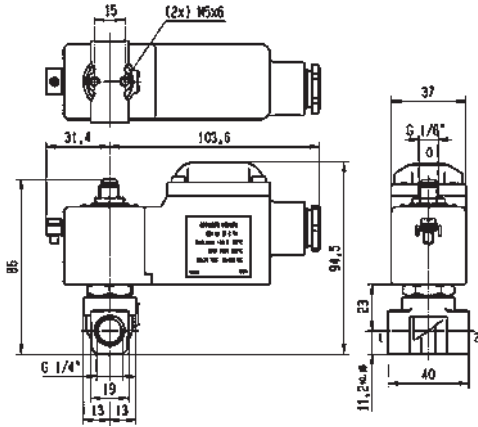

Drawing 8023

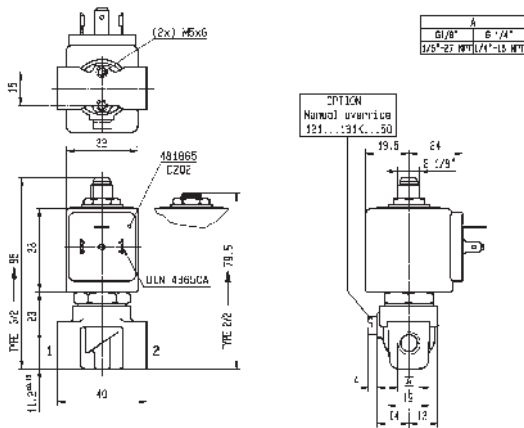

Drawing 3510

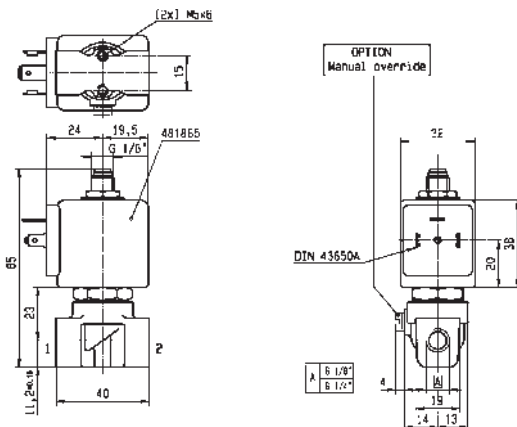

Drawing 8119

3/2

3 & 5 WAY PNEUMATIC VALVES FOR ACTUATOR CONTROL (PIPE MOUNTING) DIRECT OPERATED

BRASS

PIPE MOUNTING

NORMALLY CLOSED

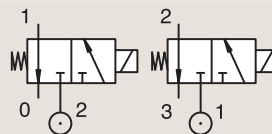

Port size	Orifice Ø	Flow factor	Operating Pressure Differential			Fluid Temp.		Seat Seal	Parker LUCIFER® Valves			ATEX Zone	Protection Mode	Power		Coil Group	Dwg. No.
			Min	Max (MOPD)	DC bar	Min	Max		Valve Ref.	Housing Ref.	Coil Ref.			AC W	DC W		
1/4"	2.5	220	0.1	7	7	-10	75	FKM	E131E03	2995	481865	-	-	8	9	2.0	3525
	2.5	220	0.1	7	7	-10	75	FKM	E131E03	4270	481000	-	-	8	8	2.0	3525
	2.5	220	0.1	7	7	-10	75	FKM	E131E03	4270	486265	-	-	14	14	2.0	3525
	2.5	220	0	7	7	-40	75	PUR	E131K0308	2995	481865	-	-	8	9	2.1	3510
	2.5	220	0	7	7	-40	75	PUR	E131K0308	4270	481000	-	-	8	8	2.1	3510
	2.5	220	0	7	7	-10	100	FKM	E131K0350 ₁	2995	481865	-	-	8	9	2.1	3510
	2.5	220	0	7	7	-10	120	FKM	E131K0350 ₁	4270	481000	-	-	8	8	2.1	3510
	4.5	500	0	2	2	-10	75	FKM	131T2101 ₁	2995	481865	-	-	8	9	2.1	3223
	4.5	500	0	2	2	-10	75	FKM	131T2101 ₁	4270	481000	-	-	8	8	2.1	3223

Notes:

1. With manual override



For this page	Port size	Orifice (mm)	Qn (l/min)	MOPD (bar)	Fluid Temp (°C)	Amb Temp (°C)
From	1/4"	2.5	220	2	-40	-40
To	1/4"	4.5	500	7	120	50

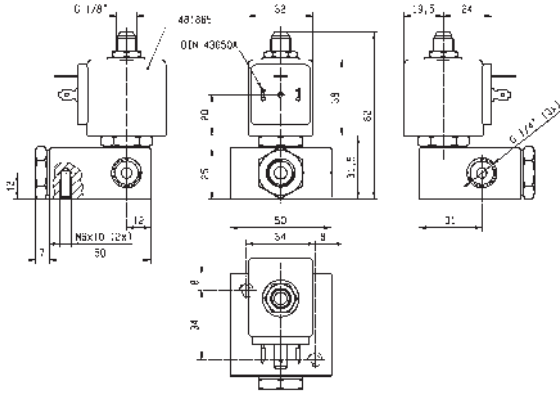

Drawing 3525

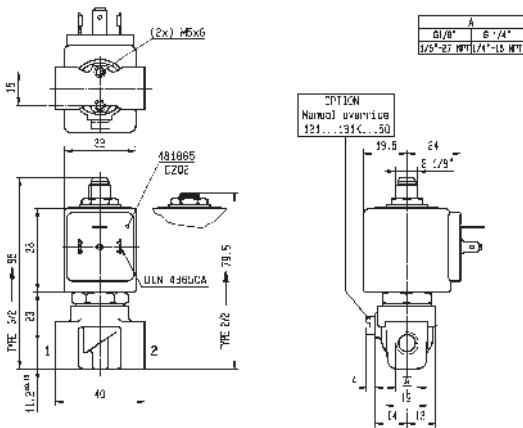

Drawing 3510

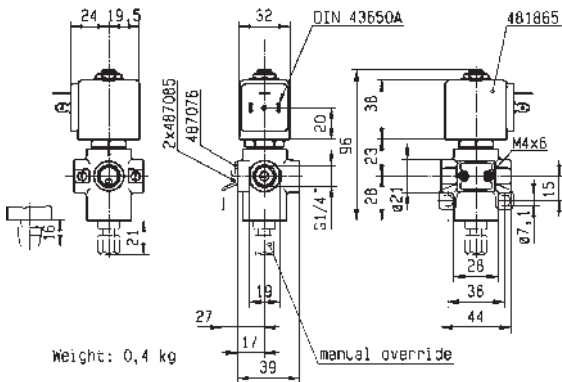

Drawing 3223

3/2

3 & 5 WAY PNEUMATIC VALVES FOR ACTUATOR CONTROL (PIPE MOUNTING) DIRECT OPERATED

BRASS

PIPE MOUNTING

NORMALLY OPEN

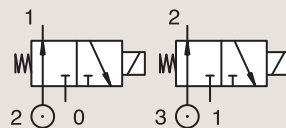

Port size	Orifice Ø 1	Flow factor Qn l/min	Operating Pressure Differential		Fluid Temp.		Seat Seal	Parker LUCIFER® Valves			ATEX Zone	Protection Mode	Power		Coil Group	Dwg. No.	
			Min	Max (MOPD)	Min	Max		Valve Ref.	Housing Ref.	Coil Ref.			AC W	DC W			
1/4"	2.5	220	0	7	3.5	-10	75	FKM	132T29	2995	481865	-	-	8	9	2.0	3223
	2.5	220	0	7	3.5	-10	75	FKM	132T29	4270	481000	-	-	8	8	2.0	3223
	2.5	220	0	-	7	-10	75	FKM	132T29	4270	486265	-	-	-	14	2.0	3223

BRASS

PIPE MOUNTING

UNIVERSAL

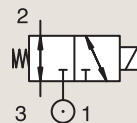

Port size	Orifice Ø 1	Flow factor Qn l/min	Operating Pressure Differential		Fluid Temp.		Seat Seal	Parker LUCIFER® Valves			ATEX Zone	Protection Mode	Power		Coil Group	Dwg. No.	
			Min	Max (MOPD)	Min	Max		Valve Ref.	Housing Ref.	Coil Ref.			AC W	DC W			
1/4" NPT	6	680	0	10	10	-25	65	NBR	U133X0111	-	492310	1-21	Ex eb mb II T3 to T6	6	6	9.0/10.1/10.2	7422
	6	680	0	-	10	-25	75	NBR	U133X0111	-	492965.01	0-20	Ex ia IIC T6	-	0.3 to 3	9.0/10.1/10.2	7422
	6	680	0	10	10	-25	65	NBR	U133X01111D ₁	-	483270	1-21	Ex db IIC T4 to T6	8	8	11.0	7438

Notes:

1. DC voltage only. Minimum drop off voltage is 15% of nominal voltage (former DIN 19251)

3/2

3 & 5 WAY PNEUMATIC VALVES FOR ACTUATOR CONTROL (PIPE MOUNTING) DIRECT OPERATED

BRASS

PIPE MOUNTING

UNIVERSAL

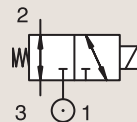

Port size	Orifice Ø 1	Flow factor Qn l/min	Operating Pressure Differential		Fluid Temp.		Seat Seal	Parker LUCIFER® Valves			ATEX Zone	Protection Mode	Power		Coil Group	Dwg. No.	
			Min	Max (MOPD)	Min	Max		Valve Ref.	Housing Ref.	Coil Ref.			AC W	DC W			
1/4" NPT	6	680	0	-	10	-25	65	NBR	U133X0131	-	492310	1-21	Ex eb mb II T3 to T6	-	6	10.1/10.2	8280
	6	680	0	-	10	-25	65	NBR	U133X0131	-	496700	1-21	Ex db mb IIC T4 to T6	-	6	10.1/10.2	8280

Notes:

1. DC voltage only (or coil with rectifier). Minimum drop off voltage is 15% of nominal voltage (former DIN 19251)

BRASS

PIPE MOUNTING

CONTROL BY ELECTRIC IMPULSE

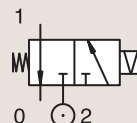

Port size	Orifice Ø 1	Flow factor Qn l/min	Operating Pressure Differential		Fluid Temp.		Seat Seal	Parker LUCIFER® Valves			ATEX Zone	Protection Mode	Power		Coil Group	Dwg. No.	
			Min	Max (MOPD)	Min	Max		Valve Ref.	Housing Ref.	Coil Ref.			AC W	DC W			
BSP	mm		bar	AC bar	DC bar	°C	°C										
1/4"	2.5	220	0	-	7	-10	100	FKM	135K03	4269	485400	-	-	-	13	4.0	3510



For this page	Port size	Orifice (mm)	Qn (l/min)	MOPD (bar)	Fluid Temp (°C)	Amb Temp (°C)
From	1/4"	2.5	220	7	-25	-25
To	1/4"	6	680	10	100	50

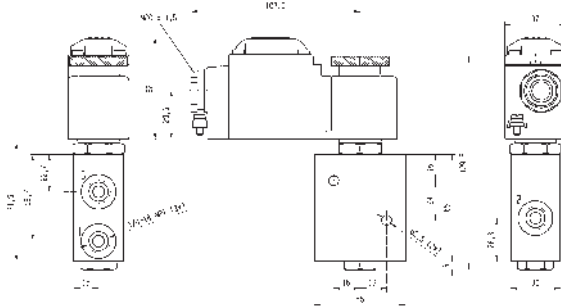

Drawing 8280

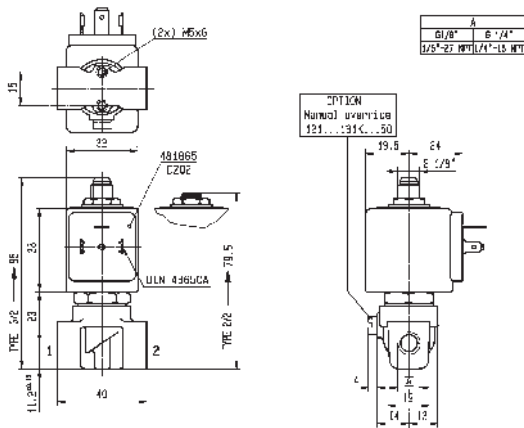

Drawing 3510

3/2

3 & 5 WAY PNEUMATIC VALVES FOR ACTUATOR CONTROL (PIPE MOUNTING) DIRECT OPERATED

BRASS

SUB-BASE MOUNTING

NORMALLY CLOSED

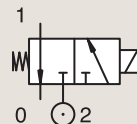

Port size	Orifice Ø 1 mm	Flow factor Qn l/min	Operating Pressure Differential			Fluid Temp.		Seat Seal	Parker LUCIFER® Valves			ATEX Zone	Protection Mode	Power		Coil Group	Dwg. No.
			Min	Max (MOPD)		Min	Max		Valve Ref.	Housing Ref.	Coil Ref.			AC W	DC W		
			bar	AC bar	DC bar	°C	°C										
SB	2.5	180	0	-	2	-20	75	PUR	131F4397	2995	482740	-	-	-	1.6	6.0/8.0	8022
	2.5	180	0	2	2	-20	75	PUR	131F4397	-	495900	1-21	Ex db mb IIC T4 to T6	2.5	2	6.0/8.0	8022
	2.5	180	0	-	2	-20	75	PUR	131F4397	-	495910	0-20	Ex ia IIC T4 to T6	-	0.3 to 3	6.0/8.0	8022
	2.5	180	0	-	2	-20	75	PUR	131F4397	2995	496125	2-22	Ex nAc nCc IIC T5/T6	-	1.6	6.0/8.0	8022

BRASS

SUB-BASE MOUNTING

UNIVERSAL

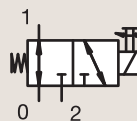

Port size	Orifice Ø 1 mm	Flow factor Qn l/min	Operating Pressure Differential			Fluid Temp.		Seat Seal	Parker LUCIFER® Valves			ATEX Zone	Protection Mode	Power		Coil Group	Dwg. No.
			Min	Max (MOPD)		Min	Max		Valve Ref.	Housing Ref.	Coil Ref.			AC W	DC W		
			bar	AC bar	DC bar	°C	°C										
SB	2	140	0	7	7	-10	100	FKM	133F4650 ₁	2995	481865	-	-	8	9	2.1	3509
	2	140	0	7	7	-10	120	FKM	133F4650 ₁	4270	481000	-	-	8	8	2.1	3509

Notes:

1. With manual override



For this page	Port size	Orifice (mm)	Qn (l/min)	MOPD (bar)	Fluid Temp (°C)	Amb Temp (°C)
From	1/8"	2	140	2	-20	-20
To	5 mm	2.5	180	7	120	50

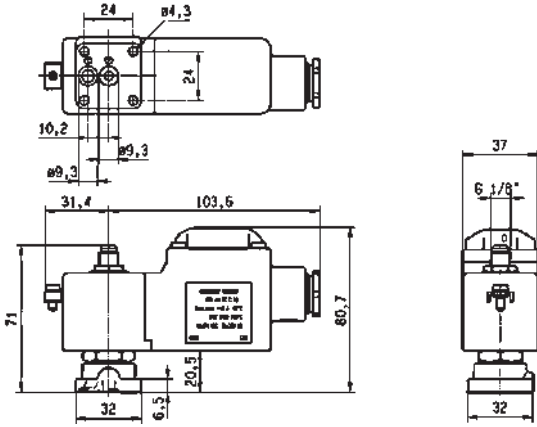

Drawing 8022

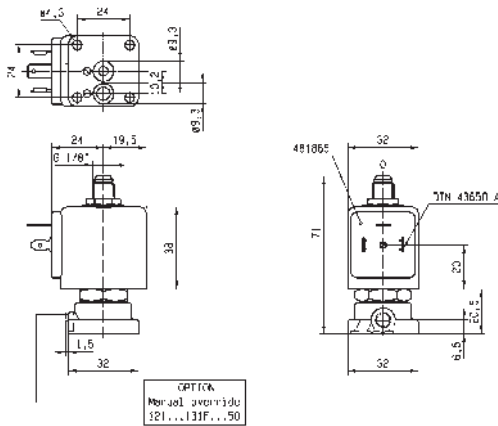

Drawing 3509

3/2

3 & 5 WAY PNEUMATIC VALVES FOR ACTUATOR CONTROL (PIPE MOUNTING) DIRECT OPERATED

ANODIZED ALUMINIUM
PIPE MOUNTING

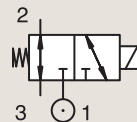

UNIVERSAL

Port size	Orifice Ø	Flow factor	Operating Pressure Differential			Fluid Temp.		Seat Seal	Parker LUCIFER® Valves			ATEX Zone	Protection Mode	Power		Coil Group	Dwg. No.
			Min	Max (MOPD)	DC bar	Min	Max		Valve Ref.	Housing Ref.	Coil Ref.			AC W	DC W		
BSP	1	Qn l/min	bar	AC bar	DC bar	°C	°C										
1/4"	6	680	0	10	10	-25	75	NBR	133X01	-	492310	1-21	Ex eb mb II T3 to T6	6	6	9.0/10.1/10.2	6960
	6	680	0	-	10	-25	65	NBR	133X01	-	492965.01	0-20	Ex ia IIC T6	-	0.3 to 3	9.0/10.1/10.2	6960
	6	680	0	10	10	-25	65	NBR	133X01	-	496700	1-21	Ex db mb IIC T4 to T6	6	6	9.0/10.1/10.2	6960
	6	680	0	10	10	-25	65	NBR	133X01	-	496895	-	-	8	8	9.0/10.1/10.2	6960
	6	680	0	10	10	-25	80	FKM	133X01001D	-	483270	1-21	Ex db IIC T4 to T6	8	8	11.0	7031
1/4" NPT	6	680	0	10	10	-25	65	NBR	U133X01	-	496700	1-21	Ex db mb IIC T4 to T6	6	6	9.0/10.1/10.2	7422

3 & 5 WAY PNEUMATIC DISTRIBUTORS



For this page	Port size	Orifice (mm)	Qn (l/min)	MOPD (bar)	Fluid Temp (°C)	Amb Temp (°C)
From	1/4"	6	680	10	-25	-25
To	1/4"	6	680	10	80	50

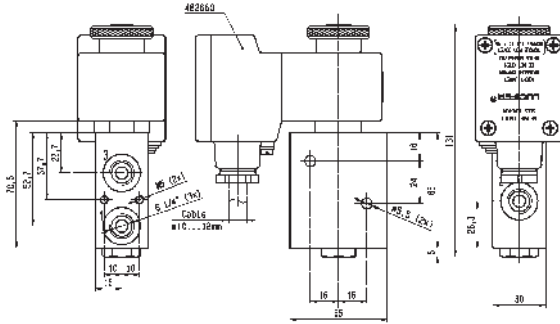

Drawing 6960

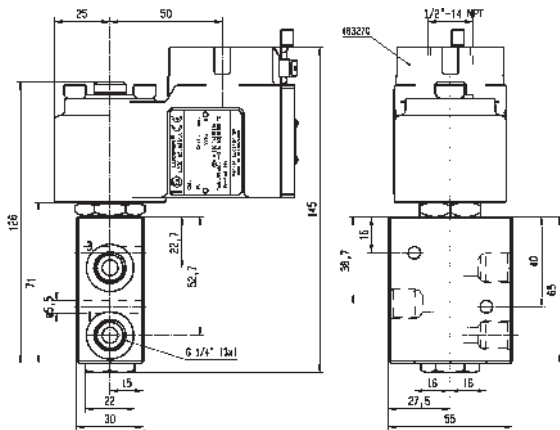

Drawing 7031

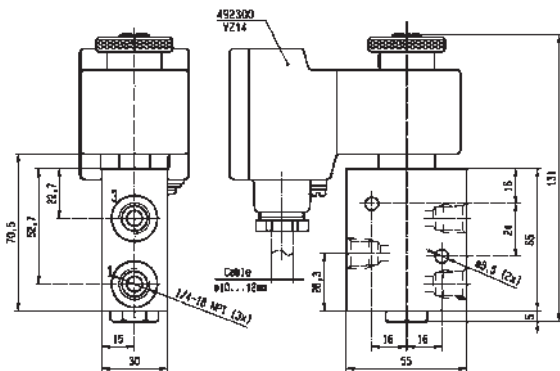

Drawing 7422

5/2

3 & 5 WAY PNEUMATIC VALVES FOR ACTUATOR CONTROL (PIPE MOUNTING) PILOT OPERATED



Process

ANODIZED ALUMINIUM PIPE MOUNTING

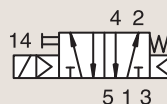

NORMALLY CLOSED

Port size	Orifice Ø	Flow factor	Operating Pressure Differential			Fluid Temp.		Seat Seal	Parker LUCIFER® Valves			ATEX Zone	Protection Mode	Power		Coil Group	Dwg. No.
			Min	Max (MOPD)	DC bar	Min	Max		Valve Ref.	Housing Ref.	Coil Ref.			AC W	DC W		
1/8"	4	600	2	10	10	-25	50	NBR	341P01 ₂	-	482606	1-21	Ex mb IIC T4/T5	2	2.5	1.1	7302
	4	600	2	10	10	-25	80	NBR	341P01 ₂	8993	488980	-	-	2	2.5	1.1	7302
	4	600	2	10	10	-25	80	NBR	341P21 ₁₂	2995	481865	-	-	8	9	2.1	7296
	4	600	2	10	10	-25	80	NBR	341P21 ₁₂	4270	481000	-	-	8	8	2.1	7296
	4	600	2	10	10	-40	65	PUR	341P2108 ₂	2995	481865	-	-	8	9	2.1	7296
	4	600	2	10	10	-40	65	PUR	341P2108 ₂	4270	481000	-	-	8	8	2.1	7296
	4	600	2	-	10	-20	65	NBR/PUR	341P2197 ₂	2995	482740	-	-	-	1.6	6.0/8.0	8027
	4	600	2	10	10	-20	65	NBR/PUR	341P2197 ₂	-	495900	1-21	Ex db mb IIC T4 to T6	2.5	2	6.0/8.0	8027
	4	600	2	-	10	-20	65	NBR/PUR	341P2197 ₂	-	495910	0-20	Ex ia IIC T4 to T6	-	0.3 to 3	6.0/8.0	8027
	4	600	2	-	10	-20	65	NBR/PUR	341P2197 ₂	2995	496125	2-22	Ex nAc nCc IIC T5/T6	-	1.6	6.0/8.0	8027

Notes:

1. Pilot seat in FKM
2. With manual override



For this page	Port size	Orifice (mm)	Qn (l/min)	MOPD (bar)	Fluid Temp (°C)	Amb Temp (°C)
From	1/8"	4	600	10	-40	-40
To	1/8"	4	600	10	80	50

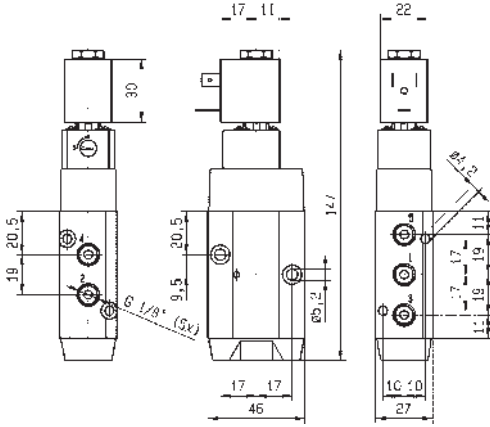

Drawing 7302

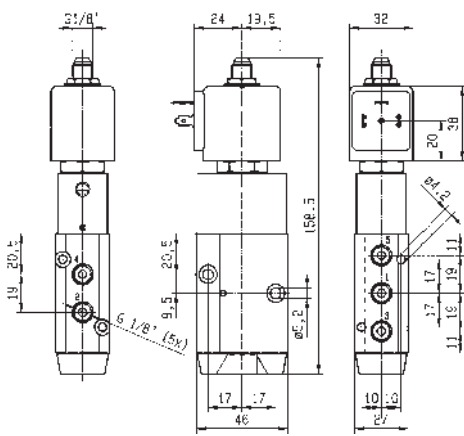

Drawing 7296

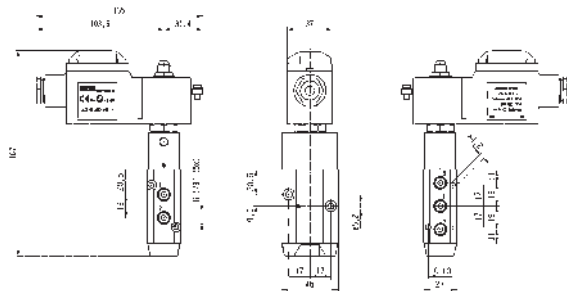

Drawing 8027

5/2

3 & 5 WAY PNEUMATIC VALVES FOR ACTUATOR CONTROL (PIPE MOUNTING) PILOT OPERATED

ANODIZED ALUMINIUM
PIPE MOUNTING

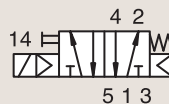

NORMALLY CLOSED

Port size	Orifice Ø	Flow factor	Operating Pressure Differential			Fluid Temp.		Seat Seal	Parker LUCIFER® Valves			ATEX Zone	Protection Mode	Power		Coil Group	Dwg. No.
			1	Min	Max (MOPD)	Min	Max		Valve Ref.	Housing Ref.	Coil Ref.			AC W	DC W		
BSP	mm	Qn l/min	bar	AC bar	DC bar	°C	°C										
1/8"	15	600	2	-	10	-10	55	NBR	341P2190 ₂	2995	483580.01	0-20	Ex ia IIC T6	-	0.5 to 3	7.0/8.0	7351
	15	600	2	-	10	-10	75	NBR	341P2190 ₂	-	488660.01	0-20	Ex ia IIC T6	-	0.3 to 3	7.0/8.0	7351
	15	600	2	-	10	-10	75	NBR	341P2190 ₂	-	495910	0-20	Ex ia IIC T4 to T6	-	0.3 to 3	7.0/8.0	7351
1/4"	7	1250	2.5	10	10	-10	50	NBR	341P03 ₂	-	496131	-	-	3	3	1.2	8218
	7	1250	2.5	10	10	-10	50	NBR	341P03 ₂	-	496482	-	-	3	3	1.2	8218
	7	1250	2.5	10	10	-10	50	NBR	341P03 ₂	-	496637	22	Ex tc IIC T95°C	3	3	1.2	8218
	7	1250	2.5	10	10	-10	50	NBR	341P33 ₂	2995	481865	-	-	8	9	2.1	8219
	7	1250	2.5	10	10	-10	50	NBR	341P33 ₂	2995	495870	2-22	Ex nAc nCc IIC T3/T4	8	9	2.1	8219
	7	1250	2.5	10	10	-10	50	NBR	341P33 ₂	-	495905	1-21	Ex db mb IIC T4	8	8	2.1	8219
	8	1400	2	10	10	-25	80	NBR	341P02 ₂	-	482606	1-21	Ex mb IIC T4/T5	2	2.5	1.1	7314
	8	1400	2	10	10	-25	80	NBR	341P02 ₂	8993	488980	-	-	2	2.5	1.1	7314

Notes:

1. Pilot seat in FKM
2. With manual override

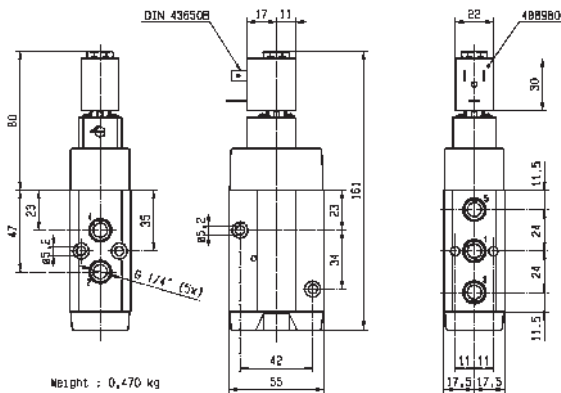

Drawing 7314



For this page	Port size	Orifice (mm)	Qn (l/min)	MOPD (bar)	Fluid Temp (°C)	Amb Temp (°C)
From	1/8"	7	600	10	-25	-25
To	1/4"	15	1400	10	80	50

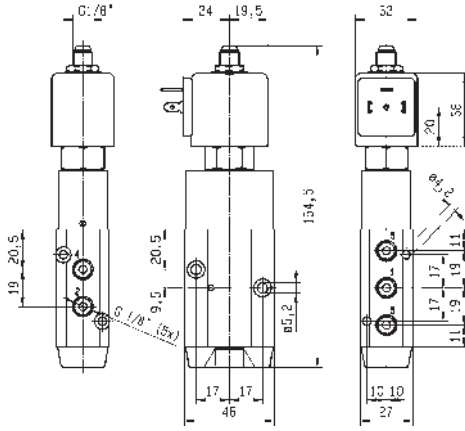

Drawing 7351

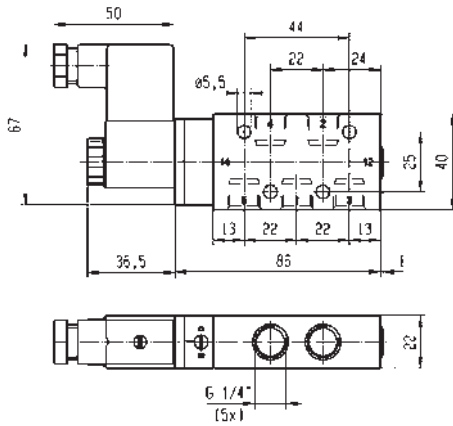

Drawing 8218

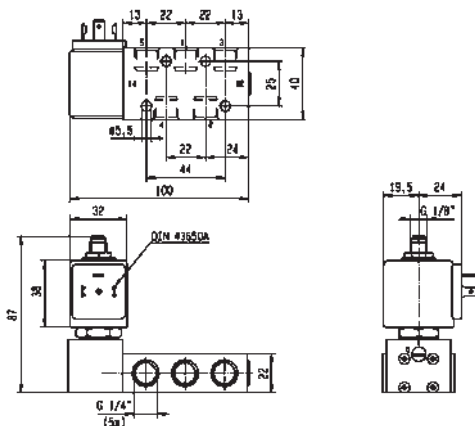

Drawing 8219

5/2

3 & 5 WAY PNEUMATIC VALVES FOR ACTUATOR CONTROL (PIPE MOUNTING) PILOT OPERATED

ANODIZED ALUMINIUM
PIPE MOUNTING

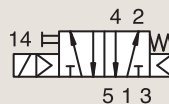

NORMALLY CLOSED

Port size	Orifice Ø	Flow factor	Operating Pressure Differential		Fluid Temp.		Seat Seal	Parker LUCIFER® Valves			ATEX Zone	Protection Mode	Power		Coil Group	Dwg. No.	
			Min	Max (MOPD)	Min	Max		Valve Ref.	Housing Ref.	Coil Ref.			AC W	DC W			
BSP	1	Qn l/min	bar	AC bar	DC bar	°C	°C										
1/4"	8	1400	2	10	10	-25	80	NBR	341P22 ₁₂	2995	481865	-	-	8	9	2.1	7319
	8	1400	2	10	10	-25	80	NBR	341P22 ₁₂	4270	481000	-	-	8	8	2.1	7319
	8	1400	2	-	10	-25	55	NBR	341P2290	2995	483580.01	0-20	Ex ia IIC T6	-	0.5 to 3	7.0/8.0	7352
	8	1400	2	-	10	-25	75	NBR	341P2290	-	488660.01	0-20	Ex ia IIC T6	-	0.3 to 3	7.0/8.0	7352
	8	1400	2	-	10	-25	75	NBR	341P2290	-	495910	0-20	Ex ia IIC T4 to T6	-	0.3 to 3	7.0/8.0	7352
	8	1400	2	-	10	-20	80	NBR	341P2297 ₂₃	2995	482740	-	-	-	1.6	6.0/8.0	8030
	8	1400	2	10	10	-20	80	NBR	341P2297 ₂₃	-	495900	1-21	Ex db mb IIC T4 to T6	2.5	2	6.0/8.0	8030
	8	1400	2	-	10	-20	80	NBR	341P2297 ₂₃	-	495910	0-20	Ex ia IIC T4 to T6	-	0.3 to 3	6.0/8.0	8030
	8	1400	2	-	10	-20	80	NBR	341P2297 ₂₃	2995	496125	2-22	Ex nAc nCc IIC T5/T6	-	1.6	6.0/8.0	8030

Notes:

1. Pilot seat in FKM
2. With manual override
3. Pilot seat in PUR



For this page	Port size	Orifice (mm)	Qn (l/min)	MOPD (bar)	Fluid Temp (°C)	Amb Temp (°C)
From	1/4"	8	1400	10	-25	-25
To	1/4"	8	1400	10	80	50

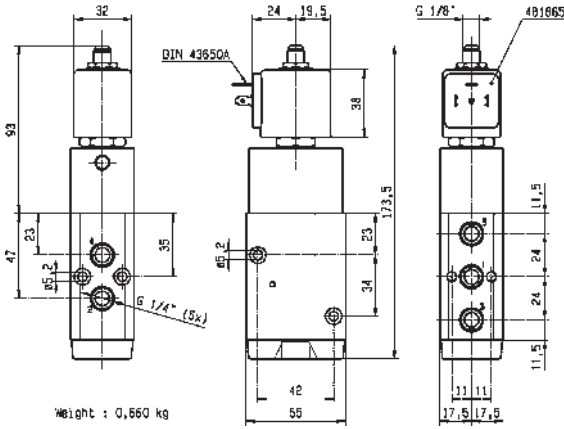

Drawing 7319

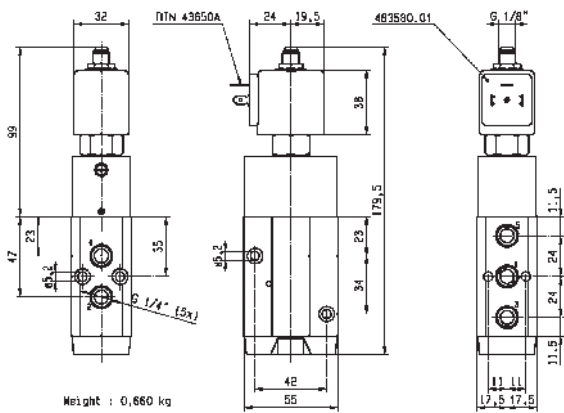

Drawing 7352

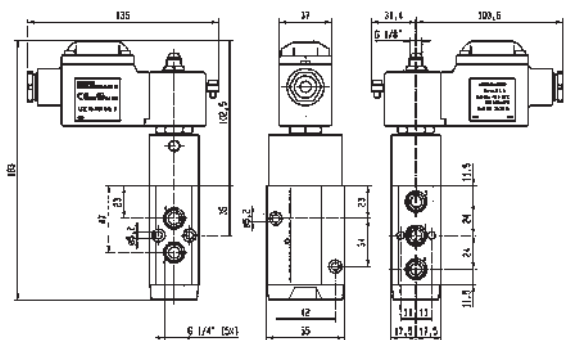

Drawing 8030

5/2

3 & 5 WAY PNEUMATIC VALVES FOR ACTUATOR CONTROL (PIPE MOUNTING) PILOT OPERATED

ANODIZED ALUMINIUM
PIPE MOUNTING

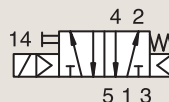

NORMALLY CLOSED

Port size	Orifice Ø	Flow factor	Operating Pressure Differential			Fluid Temp.		Seat Seal	Parker LUCIFER® Valves			ATEX Zone	Protection Mode	Power		Coil Group	Dwg. No.
			Min	Max (MOPD)		Min	Max		Valve Ref.	Housing Ref.	Coil Ref.			AC W	DC W		
BSP	mm	Qn l/min	bar	AC bar	DC bar	°C	°C										
1/2"	12	3000	2.5	10	10	-10	50	NBR	341P04 ₁	-	496131	-	-	3	3	1.2	8220
	12	3000	2.5	10	10	-10	50	NBR	341P04 ₁	-	496482	-	-	3	3	1.2	8220
	12	3000	2.5	10	10	-10	50	NBR	341P04 ₁	-	496637	22	Ex tc IIC T95°C	3	3	1.2	8220
	12	3000	2.5	10	10	-10	50	NBR	341P34 ₁	2995	481865	-	-	8	9	2.1	8221
	12	3000	2.5	10	10	-10	50	NBR	341P34 ₁	2995	495870	2-22	Ex nAc nCc IIC T3/T4	8	9	2.1	8221
	12	3000	2.5	10	10	-10	50	NBR	341P34 ₁	-	495905	1-21	Ex db mb IIC T4	8	8	2.1	8221

Notes:

1. With manual override



For this page	Port size	Orifice (mm)	Qn (l/min)	MOPD (bar)	Fluid Temp (°C)	Amb Temp (°C)
From	1/2"	12	3000	10	-10	-10
To	1/2"	12	3000	10	50	50

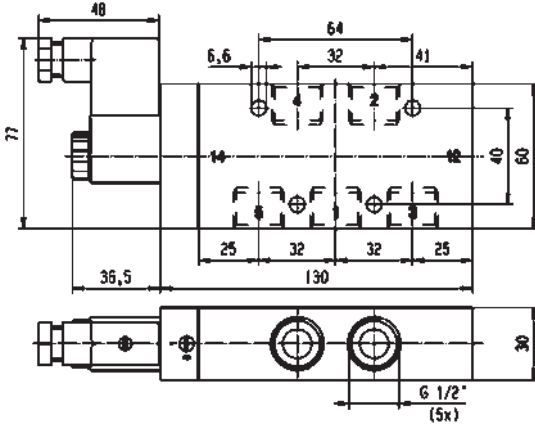

Drawing 8220

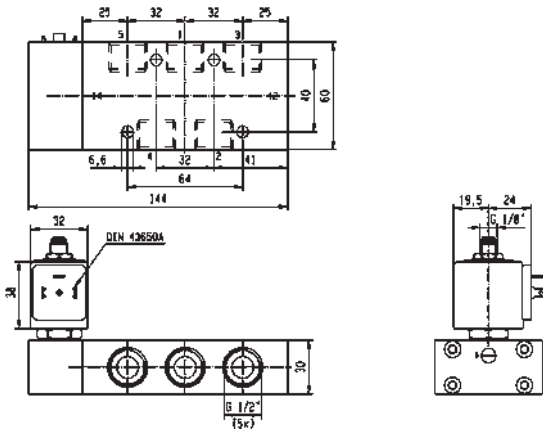

Drawing 8221

5/2

3 & 5 WAY PNEUMATIC VALVES FOR ACTUATOR CONTROL (PIPE MOUNTING) PILOT OPERATED

ANODIZED ALUMINIUM PIPE MOUNTING

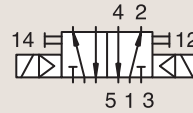

DUAL SOLENOIDS

Port size	Orifice Ø	Flow factor	Operating Pressure Differential			Fluid Temp.		Seat Seal	Parker LUCIFER® Valves			ATEX Zone	Protection Mode	Power		Coil Group	Dwg. No.
			Min	Max (MOPD)	DC bar	Min	Max		Valve Ref.	Housing Ref.	Coil Ref.			AC W	DC W		
BSP	mm	Qn l/min	bar	AC bar	DC bar	°C	°C										
1/8"	4	400	2	10	10	-25	80	NBR	347P01 ₂	-	482606	1-21	Ex mb IIC T4/T5	2	2.5	1.1	7306
	4	400	2	10	10	-25	80	NBR	347P01 ₂	8993	488980	-	-	2	2.5	1.1	7306
	4	400	2	10	10	-25	80	NBR	347P21 ₁₂	2995	481865	-	-	8	9	2.1	7298
	4	400	2	10	10	-25	80	NBR	347P21 ₁₂	4270	481000	-	-	8	8	2.1	7298
	4	400	2	-	10	-25	55	NBR	347P2190	2995	483580.01	0-20	Ex ia IIC T6	-	0.5 to 3	7.0/8.0	7353
	4	400	2	-	10	-25	75	NBR	347P2190	-	488660.01	0-20	Ex ia IIC T6	-	0.3 to 3	7.0/8.0	7353
	4	400	2	-	10	-25	75	NBR	347P2190	-	495910	0-20	Ex ia IIC T4 to T6	-	0.3 to 3	7.0/8.0	7353
	4	400	2	-	10	-20	65	NBR/PUR	347P2197 ₂	2995	482740	-	-	-	1.6	6.0/8.0	8028
	4	400	2	10	10	-20	65	NBR/PUR	347P2197 ₂	-	495900	1-21	Ex db mb IIC T4 to T6	2.5	2	6.0/8.0	8028
	4	400	2	-	10	-20	65	NBR/PUR	347P2197 ₂	-	495910	0-20	Ex ia IIC T4 to T6	-	0.3 to 3	6.0/8.0	8028
	4	400	2	-	10	-20	65	NBR/PUR	347P2197 ₂	2995	496125	2-22	Ex nAc nCc IIC T5/T6	-	1.6	6.0/8.0	8028

Notes:

- 1. Pilot seat in FKM
- 2. With manual override

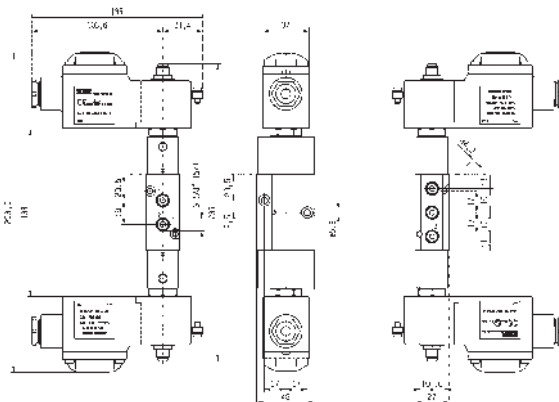

Drawing 8028



For this page	Port size	Orifice (mm)	Qn (l/min)	MOPD (bar)	Fluid Temp (°C)	Amb Temp (°C)
From	1/8"	4	400	10	-25	-25
To	1/8"	4	400	10	80	50

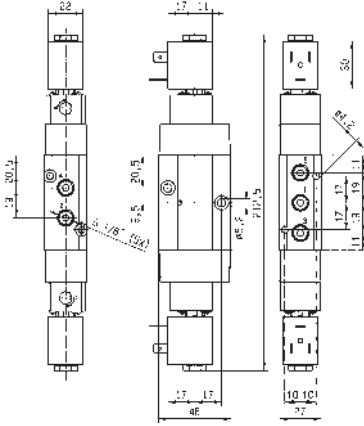

Drawing 7306

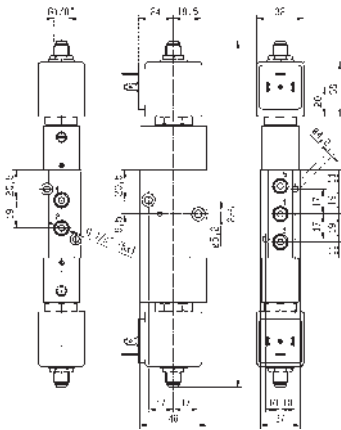

Drawing 7298

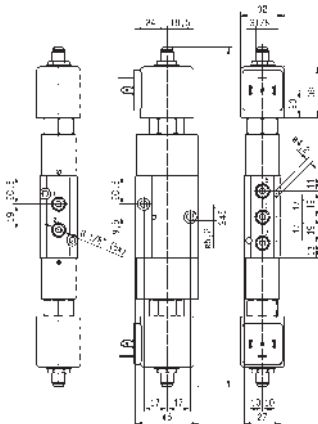

Drawing 7353

5/2

3 & 5 WAY PNEUMATIC VALVES FOR ACTUATOR CONTROL (PIPE MOUNTING) PILOT OPERATED

ANODIZED ALUMINIUM PIPE MOUNTING

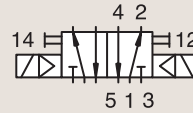

DUAL SOLENOIDS

Port size	Orifice Ø	Flow factor	Operating Pressure Differential			Fluid Temp.		Seat Seal	Parker LUCIFER® Valves			ATEX Zone	Protection Mode	Power		Coil Group	Dwg. No.
			Min	Max (MOPD)	DC	Valve Ref.	Housing Ref.		Coil Ref.	AC W	DC W						
BSP	1	Qn l/min	bar	AC bar	DC bar	Min °C	Max °C										
	7	1250	2.5	10	10	-10	50	NBR	347P03 ₂	-	496131	-	-	3	3	1.2	8222
	7	1250	2.5	10	10	-10	50	NBR	347P03 ₂	-	496482	-	-	3	3	1.2	8222
	7	1250	2.5	10	10	-10	50	NBR	347P03 ₂	-	496637	22	Ex tc IIIC T95°C	3	3	1.2	8222
1/4"	7	1250	2.5	10	10	-10	50	NBR	347P33 ₁₂	2995	481865	-	-	8	9	2.1	8223
	7	1250	2.5	10	10	-10	50	NBR	347P33 ₁₂	2995	495870	2-22	Ex nAc nCc IIC T3/T4	8	9	2.1	8223
	7	1250	2.5	10	10	-10	50	NBR	347P33 ₁₂	-	495905	1-21	Ex db mb IIC T4	8	8	2.1	8223
	8	1400	2	10	10	-25	80	NBR	347P02 ₂	-	482606	1-21	Ex mb IIC T4/T5	2	2.5	1.1	7316
	8	1400	2	10	10	-25	80	NBR	347P02 ₂	8993	488980	-	-	2	2.5	1.1	7316
	8	1400	2	10	10	-25	80	NBR	347P22 ₁₂	2995	481865	-	-	8	9	2.1	7321
	8	1400	2	10	10	-25	80	NBR	347P22 ₁₂	4270	481000	-	-	8	8	2.1	7321

Notes:

- 1. Pilot seat in FKM
- 2. With manual override

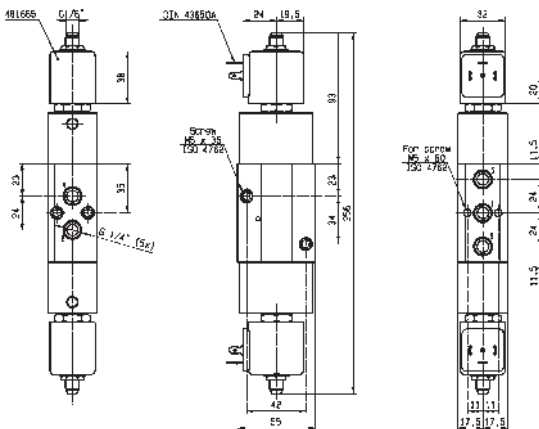

Drawing 7321

3 & 5 WAY PNEUMATIC DISTRIBUTORS



For this page	Port size	Orifice (mm)	Qn (l/min)	MOPD (bar)	Fluid Temp (°C)	Amb Temp (°C)
From	1/4"	7	1250	10	-25	-25
To	1/4"	8	1400	10	80	50

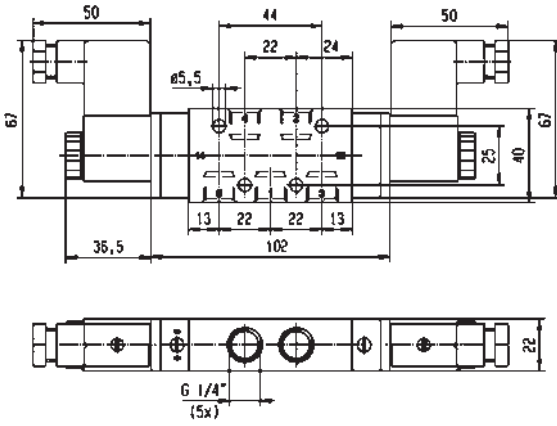

Drawing 8222

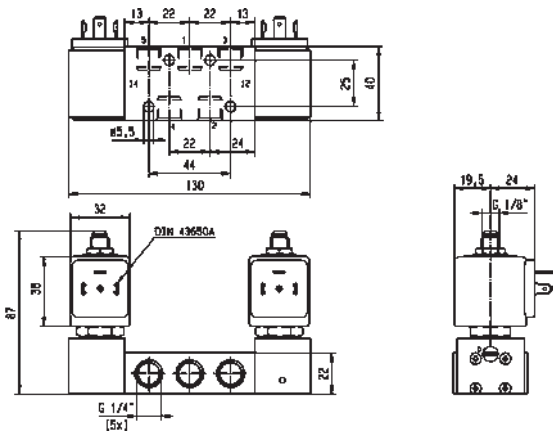

Drawing 8223

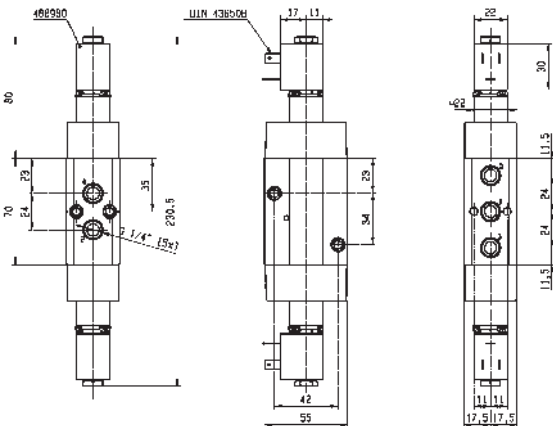

Drawing 7316

5/2

3 & 5 WAY PNEUMATIC VALVES FOR ACTUATOR CONTROL (PIPE MOUNTING) PILOT OPERATED

ANODIZED ALUMINIUM PIPE MOUNTING

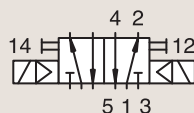

DUAL SOLENOIDS

Port size	Orifice Ø 1	Flow factor Qn l/min	Operating Pressure Differential			Fluid Temp.		Seat Seal	Parker LUCIFER® Valves			ATEX Zone	Protection Mode	Power		Coil Group	Dwg. No.
			Min	Max (MOPD)	DC bar	Min	Max		Valve Ref.	Housing Ref.	Coil Ref.			AC W	DC W		
			bar	AC bar	°C	°C											
1/2"	12	3000	2.5	10	10	-10	50	NBR	347P04 ₂	-	496131	-	-	3	3	1.2	8224
	12	3000	2.5	10	10	-10	50	NBR	347P04 ₂	-	496482	-	-	3	3	1.2	8224
	12	3000	2.5	10	10	-10	50	NBR	347P04 ₂	-	496637	22	Ex tc IIIC T95°C	3	3	1.2	8224
	12	3000	2.5	10	10	-10	50	NBR	347P34 ₁₂	2995	481865	-	-	8	9	2.1	8225
	12	3000	2.5	10	10	-10	50	NBR	347P34 ₁₂	2995	495870	2-22	Ex nAc nCc IIC T3/T4	8	9	2.1	8225
	12	3000	2.5	10	10	-10	50	NBR	347P34 ₁₂	-	495905	1-21	Ex db mb IIC T4	8	8	2.1	8225

Notes:

1. Pilot seat in FKM
2. With manual override

ANODIZED ALUMINIUM PIPE MOUNTING

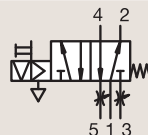

CONTROL BY ELECTRIC IMPULSE

Port size	Orifice Ø 1	Flow factor Qn l/min	Operating Pressure Differential			Fluid Temp.		Seat Seal	Parker LUCIFER® Valves			ATEX Zone	Protection Mode	Power		Coil Group	Dwg. No.
			Min	Max (MOPD)	DC bar	Min	Max		Valve Ref.	Housing Ref.	Coil Ref.			AC W	DC W		
			bar	AC bar	°C	°C											
1/8"	4	600	2	-	10	-25	80	NBR	345P21	4269	485400	-	-	-	13	4.0	8123

3 & 5 WAY PNEUMATIC DISTRIBUTORS



For this page	Port size	Orifice (mm)	Qn (l/min)	MOPD (bar)	Fluid Temp (°C)	Amb Temp (°C)
From	1/8"	4	600	10	-25	-25
To	1/2"	12	3000	10	80	50

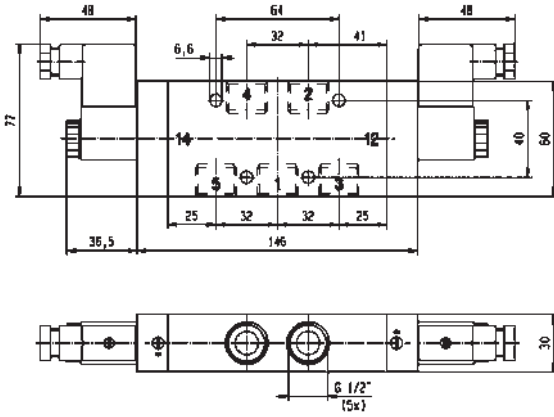

Drawing 8224

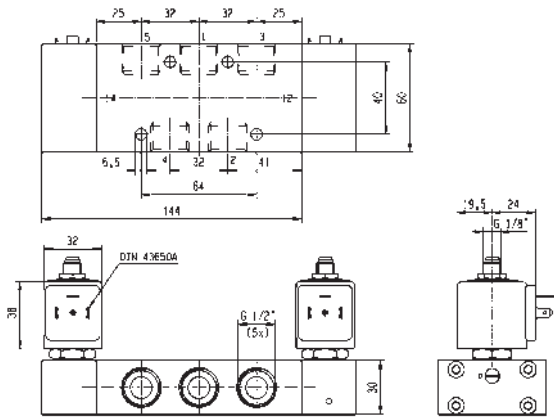

Drawing 8225

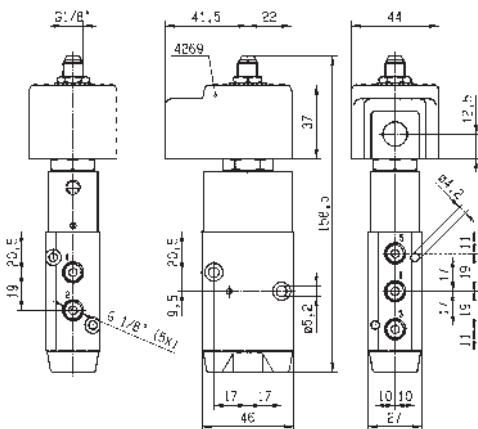

Drawing 8123

3/2

3 & 5 WAY PNEUMATIC VALVES FOR ACTUATOR CONTROL (PIPE MOUNTING) MANUAL RESET



Process

BRASS PIPE MOUNTING

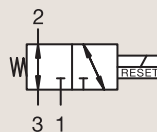

UNIVERSAL

Port size	Orifice Ø 1 mm	Flow factor Qn l/min	Operating Pressure Differential			Fluid Temp.		Seat Seal	Parker LUCIFER® Valves			ATEX Zone	Protection Mode	Power		Coil Group	Dwg. No.
			Min bar	Max (MOPD) AC bar	DC bar	Min °C	Max °C		Valve Ref.	Housing Ref.	Coil Ref.			AC W	DC W		
1/4" NPT	6	680	0	10	10	-25	65	NBR	U033X0111	-	492310	1-21	Ex eb mb II T3 to T6	6	6	10.1/10.2/12.0	7641
	6	680	0	10	10	-25	65	NBR	U033X0111	-	496700	1-21	Ex db mb IIC T4 to T6	6	6	10.1/10.2/12.0	7641



For this page	Port size	Orifice (mm)	Qn (l/min)	MOPD (bar)	Fluid Temp (°C)	Amb Temp (°C)
From	1/4"	6	680	10	-25	-25
To	1/4"	6	680	10	65	65

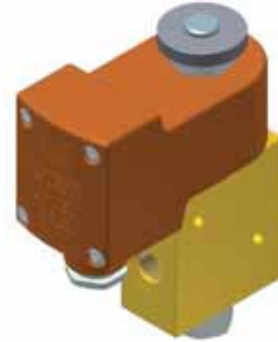
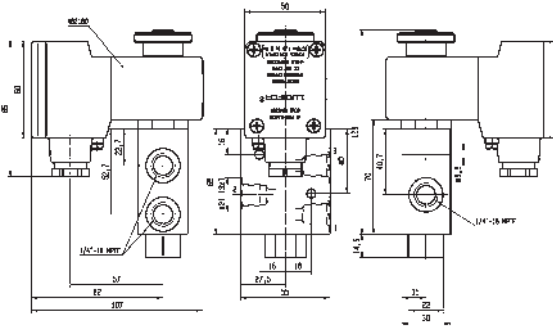

Drawing 7641



3 & 5 WAY PNEUMATIC VALVES FOR ACTUATOR CONTROL (NAMUR)



3/2
5/2
5/3

Actuation	Body	Function	Port Size	Orifice (mm)	Qn (l/min)	MOPD (bar)	Max Fluid Temp. (°C)	Page Parker Valves	Page Parker LUCIFER® Valves	
Direct Operated	Anodized aluminium/ NAMUR	Normally Closed	1/4"	6	680	10	75	-	334	
		Pilot Operated	Solenoid operated - spring return	1/8"-1/4"	4 to 8	1400	10	80	-	340
1/4"	7 to 8			1400	10	80	-	336		
1/2"	12			3000	10	50	-	336		
Dual Solenoids	1/8"-1/4"		4	400	10	80	-	352		
	1/4"		7 to 8	1400	10	120	-	354		
	1/2"		12	3000	10	120	-	356		
W1 closed center position	1/8"-1/4"		4	400	10	80	-	358		
	1/4"		4 to 7	1250	10	120	-	358		
W3 exhausted in center position	1/4"		7	1250	10	50	-	360		
Control by Electric Impulse	1/8"-1/4"		4	600	10	80	-	362		
Air Operated	Anodized aluminium/ NAMUR/Poppet		Solenoid operated - spring return	1/8"-1/4"	4	355	10	75	-	362
	Anodized aluminium/ NAMUR		W1 closed center position	1/4"	7	1250	10	50	-	372
		Air operated - spring return	1/8"-1/4"	4	600	10	80	-	368	
			1/4"	7	1250	10	50	-	366	
			1/2"	12	3000	10	50	-	366	
		Air operated and return	1/4"	7	1250	10	50	-	370	

3/2

3 & 5 WAY PNEUMATIC VALVES FOR ACTUATOR CONTROL (NAMUR) DIRECT OPERATED



Process

ANODIZED ALUMINIUM NAMUR

NORMALLY CLOSED

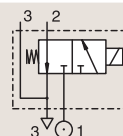

Port size	Orifice Ø	Flow factor	Operating Pressure Differential			Fluid Temp.		Seat Seal	Parker LUCIFER® Valves			ATEX Zone	Protection Mode	Power		Coil Group	Dwg. No.
			Min	Max (MOPD)	DC bar	Min	Max		Valve Ref.	Housing Ref.	Coil Ref.			AC W	DC W		
BSP	1	Qn l/min	bar	AC bar	DC bar	°C	°C										
1/4"	6	680	0	10	10	-25	75	NBR	131X1101	-	492310	1-21	Ex eb mb II T3 to T6	6	6	9.0/10.1	7336
	6	680	0	-	10	-25	75	NBR	131X1101	-	492965.01	0-20	Ex ia IIC T6	-	0.3 to 3	9.0/10.1	7336
	6	680	0	10	10	-25	75	NBR	131X1101	-	496700	1-21	Ex db mb IIC T4 to T6	6	6	9.0/10.1	7336
	6	680	0	10	10	-25	75	NBR	131X1101	-	496895	-	-	8	8	9.0/10.1	7336
	6	680	0	-	10	-25	65	NBR	131X1131	-	492310	1-21	Ex eb mb II T3 to T6	-	6	10.1/10.2	7336
	6	680	0	-	10	-25	65	NBR	131X1131	-	496700	1-21	Ex db mb IIC T4 to T6	-	6	10.1/10.2	7336
	6	680	0	-	10	-25	65	NBR	131X1131	-	496895	-	-	-	8	10.1/10.2	7336
1/4" NPT	6	680	0	-	10	-25	75	NBR	U131X1101	-	492965.01	0-20	Ex ia IIC T6	-	0.3 to 3	10.1/10.2	7336
	6	680	0	10	10	-25	65	NBR	U131X1101	-	496700	1-21	Ex db mb IIC T4 to T6	6	6	10.1/10.2	7336
	6	680	0	10	10	-25	65	NBR	U131X1101	-	496895	-	-	8	8	10.1/10.2	7336

Notes:

1. DC voltage only. Minimum drop off voltage is 15% of nominal voltage (former DIN 19251)



For this page	Port size	Orifice (mm)	Qn (l/min)	MOPD (bar)	Fluid Temp (°C)	Amb Temp (°C)
From	1/4"	6	680	10	-25	-25
To	1/4"	6	680	10	75	65

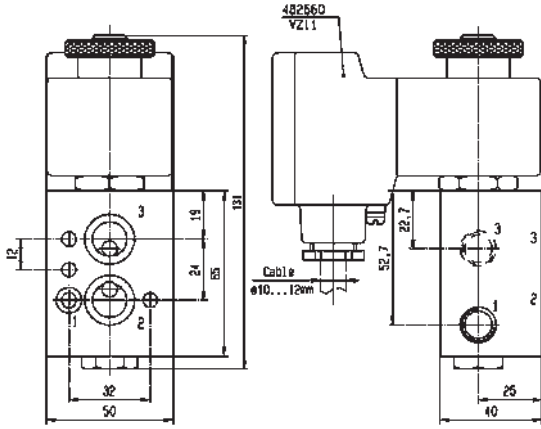

Drawing 7336

3/2

3 & 5 WAY PNEUMATIC VALVES FOR ACTUATOR CONTROL (NAMUR) PILOT OPERATED



Process

ANODIZED ALUMINIUM NAMUR

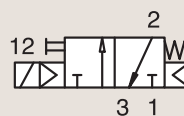

SOLENOID OPERATED - SPRING RETURN

Port size	Orifice Ø	Flow factor	Operating Pressure Differential			Fluid Temp.		Seat Seal	Parker LUCIFER® Valves			ATEX Zone	Protection Mode	Power		Coil Group	Dwg. No.
			Min	Max (MOPD)	DC bar	Min	Max		Valve Ref.	Housing Ref.	Coil Ref.			AC W	DC W		
BSP	1	Qn l/min	bar	AC bar	DC bar	°C	°C										
1/4"	7	1250	2.5	10	10	-10	50	NBR	331N03 ₁	-	496131	-	-	3	3	1.2	8056
	7	1250	2.5	10	10	-10	50	NBR	331N03 ₁	-	496482	-	-	3	3	1.2	8056
	7	1250	2.5	10	10	-10	50	NBR	331N03 ₁	-	496637	22	Ex tc IIC T95°C	3	3	1.2	8056
1/2"	12	3000	2.5	10	10	-10	50	NBR	331N04 ₁	-	496131	-	-	3	3	1.2	8060
	12	3000	2.5	10	10	-10	50	NBR	331N04 ₁	-	496482	-	-	3	3	1.2	8060
	12	3000	2.5	10	10	-10	50	NBR	331N04 ₁	-	496637	22	Ex tc IIC T95°C	3	3	1.2	8060
	12	3000	2.5	10	10	-10	50	NBR	331N0402	-	496131	-	-	3	3	1.2	8251
	12	3000	2.5	10	10	-10	50	NBR	331N0402	-	496482	-	-	3	3	1.2	8251

Notes:

1. With manual override



For this page	Port size	Orifice (mm)	Qn (l/min)	MOPD (bar)	Fluid Temp (°C)	Amb Temp (°C)
From	1/4"	7	1250	10	-10	-10
To	1/2"	12	3000	10	50	50

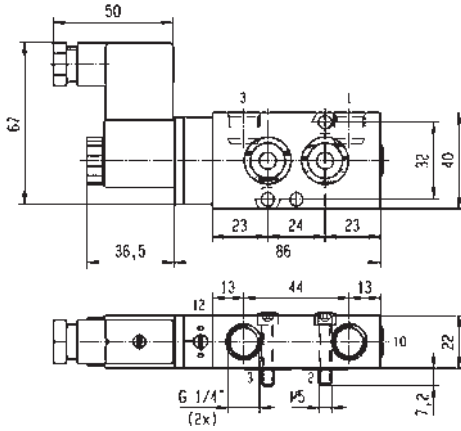

Drawing 8056

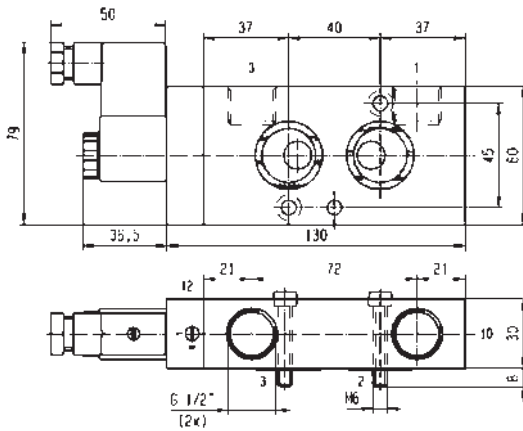

Drawing 8060

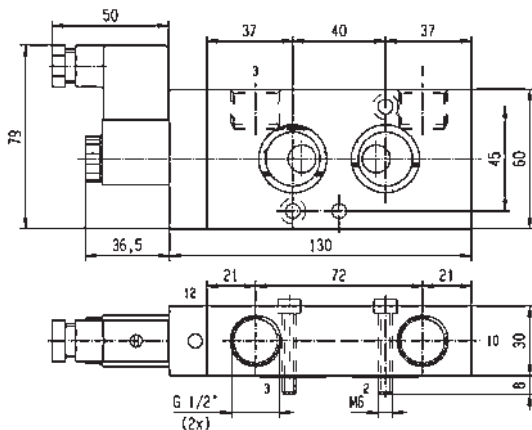

Drawing 8251

3/2

3 & 5 WAY PNEUMATIC VALVES FOR ACTUATOR CONTROL (NAMUR) PILOT OPERATED

ANODIZED ALUMINIUM
NAMUR

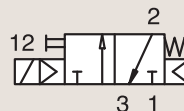

SOLENOID OPERATED - SPRING RETURN

Port size	Orifice Ø	Flow factor	Operating Pressure Differential			Fluid Temp.		Seat Seal	Parker LUCIFER® Valves			ATEX Zone	Protection Mode	Power		Coil Group	Dwg. No.
			Min	Max (MOPD)		Min	Max		Valve Ref.	Housing Ref.	Coil Ref.			AC W	DC W		
BSP	1	Qn l/min	bar	AC bar	DC bar	°C	°C										
1/2"	12	3000	2.5	10	10	-10	50	NBR	331N34 ₁₂	2995	481865	-	-	8	9	2.1	8210
	12	3000	2.5	10	10	-10	50	NBR	331N34 ₁₂	2995	495870	2-22	Ex nAc nCc IIC T3/T4	8	9	2.1	8210
	12	3000	2.5	10	10	-10	50	NBR	331N34 ₁₂	-	495905	1-21	Ex db mb IIC T4	8	8	2.1	8210
	12	3000	2.5	10	10	-10	50	NBR	331N3402 ₂	2995	481865	-	-	8	9	2.1	8252

Notes:

1. With manual override
2. Pilot seat in FKM



For this page	Port size	Orifice (mm)	Qn (l/min)	MOPD (bar)	Fluid Temp (°C)	Amb Temp (°C)
From	1/2"	12	3000	10	-10	-10
To	1/2"	12	3000	10	50	50

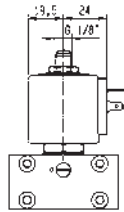
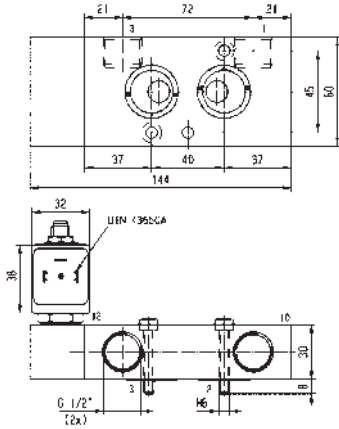

Drawing 8210

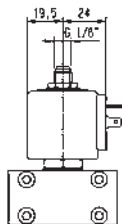
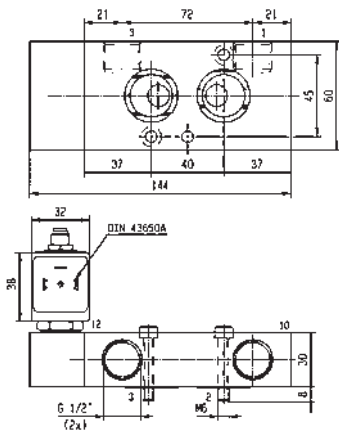

Drawing 8252

3/2-5/2

3 & 5 WAY PNEUMATIC VALVES FOR ACTUATOR CONTROL (NAMUR) PILOT OPERATED

ANODIZED ALUMINIUM
NAMUR

SOLENOID OPERATED - SPRING RETURN

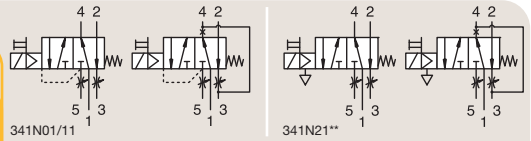

Port size	Orifice Ø	Flow factor	Operating Pressure Differential			Fluid Temp.		Seat Seal	Parker LUCIFER® Valves			ATEX Zone	Protection Mode	Power		Coil Group	Dwg. No.
			Min	Max (MOPD)	Max	Min	Max		Valve Ref.	Housing Ref.	Coil Ref.			AC W	DC W		
BSP	mm	Qn l/min	bar	AC bar	DC bar	°C	°C										
1/8"-1/4"	4	600	2	10	10	-25	80	NBR	341N01 ₁₂	8993	488980	-	-	2	2.5	1.1	7301
	4	600	2	10	10	-25	80	NBR	341N11 ₁₂	8993	488980	-	-	2	2.5	1.1	7300
	4	600	2	10	10	-25	80	NBR	341N21 ₁₂	2995	481865	-	-	8	9	2.1	7311
	4	600	2	10	10	-25	80	NBR	341N21 ₁₂	4270	481000	-	-	8	8	2.1	7311
	4	600	2	-	10	-25	55	NBR	341N2190 ₁₂	2995	483580.01	0-20	Ex ia IIC T6	-	0.5 to 3	7.0/8.0	7874
	4	600	2	-	10	-25	55	NBR	341N2190 ₁₂	-	495910	0-20	Ex ia IIC T4 to T6	-	0.3 to 3	7.0/8.0	7874

Notes:

- 1. With captured exhaust
- 2. With manual override

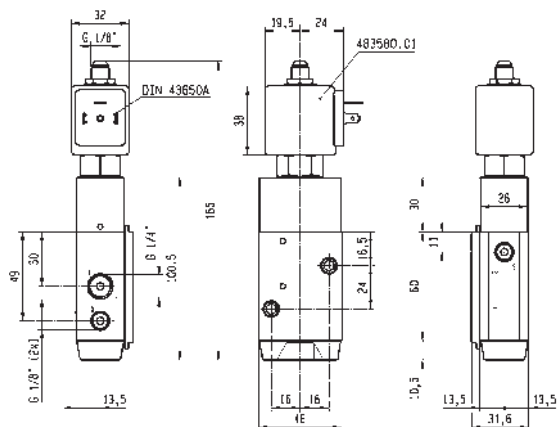

Drawing 7874



For this page	Port size	Orifice (mm)	Qn (l/min)	MOPD (bar)	Fluid Temp (°C)	Amb Temp (°C)
From	1/8"-1/4"	4	600	10	-25	-25
To	1/8"-1/4"	4	600	10	80	50

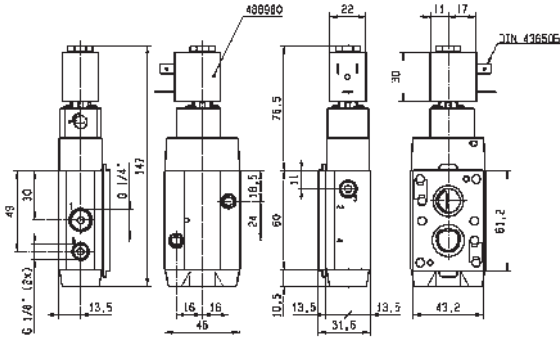

Drawing 7301

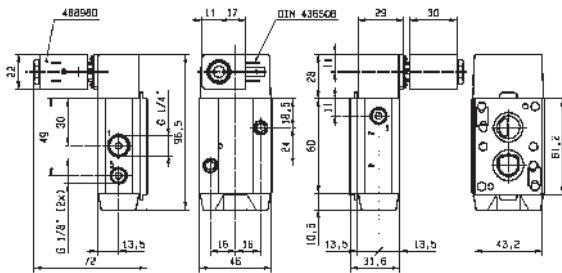

Drawing 7300

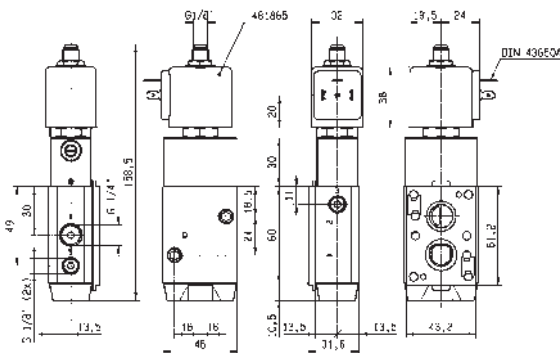

Drawing 7311

3/2-5/2

3 & 5 WAY PNEUMATIC VALVES FOR ACTUATOR CONTROL (NAMUR) PILOT OPERATED

**ANODIZED ALUMINIUM
NAMUR**

SOLENOID OPERATED - SPRING RETURN

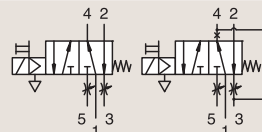

Port size	Orifice Ø	Flow factor	Operating Pressure Differential			Fluid Temp.		Seat Seal	Parker LUCIFER® Valves			ATEX Zone	Protection Mode		Power		Coil Group	Dwg. No.
			Min	Max (MOPD)	DC bar	Min	Max		Valve Ref.	Housing Ref.	Coil Ref.		AC W	DC W				
1/8" 1/4"	4	600	2	10	10	-25	80	NBR	341N31 ₃₄	2995	481865	-	-	8	9	2.1	7295	
	4	600	2	10	10	-25	80	NBR	341N31 ₃₄	2995	495870	2-22	Ex nAc nCc IIC T3/T4	8	9	2.1	7295	
	4	600	2	10	10	-25	65	NBR	341N31 ₃₄	-	495905	1-21	Ex db mb IIC T4	8	8	2.1	7295	
	4	600	2	10	10	-25	80	NBR	341N3102 ₄	2995	481865	-	-	8	9	2.1	7295	
	4	600	2	10	10	-40	65	PUR	341N3108 ₃	2995	481865	-	-	8	9	2.1	7295	
	4	600	2	10	10	-40	65	PUR	341N3108 ₃	4270	481000	-	-	8	8	2.1	7295	
	4	600	2	10	10	-40	65	PUR	341N3128	2995	481865	-	-	8	9	2.1	7295	
	4	600	2	10	10	-40	65	PUR	341N3128	4270	481865	-	-	8	9	2.1	7295	
	4	600	2	-	10	-25	80	NBR	341N3130 ₁₃₄	2995	481865	-	-	-	9	2.1	7295	
	4	600	2	-	10	-25	80	NBR	341N3130 ₁₃₄	-	492190	1-21	Ex eb mb IIC T3/T4	-	9	2.1	7295	
	4	600	2	-	10	-25	80	NBR	341N3130 ₁₃₄	-	495905	1-21	Ex db mb IIC T4	-	8	2.1	7295	
	4	600	2	-	10	-10	55	NBR	341N3190	2995	483580.01	0-20	Ex ia IIC T6	-	0.5 to 3	7.0/8.0	7349	
	4	600	2	-	10	-10	75	NBR	341N3190	-	488660.01	0-20	Ex ia IIC T6	-	0.3 to 3	7.0/8.0	7349	
	4	600	2	-	10	-10	75	NBR	341N3190	-	495910	0-20	Ex ia IIC T4 to T6	-	0.3 to 3	7.0/8.0	7349	
	4	600	2	-	10	-25	65	NBR	341N3196 ₅	2995	482740	-	-	-	1.6	6.0/8.0	8017	
	4	600	2	10	10	-25	65	NBR	341N3196 ₅	-	495900	1-21	Ex db mb IIC T4 to T6	2.5	2	6.0/8.0	8017	
	4	600	2	-	10	-25	65	NBR	341N3196 ₅	-	495910	0-20	Ex ia IIC T4 to T6	-	0.3 to 3	6.0/8.0	8017	
	4	600	2	-	10	-25	65	NBR	341N3196 ₅	2995	496125	2-22	Ex nAc nCc IIC T5/T6	-	1.6	6.0/8.0	8017	
	4	600	2	-	10	-25	65	NBR	341N3197 ₃₅	2995	482740	-	-	-	1.6	6.0/8.0	8017	
	4	600	2	10	10	-25	65	NBR	341N3197 ₃₅	-	495900	1-21	Ex db mb IIC T4 to T6	2.5	2	6.0/8.0	8017	
4	600	2	-	10	-25	65	NBR	341N3197 ₃₅	-	495910	0-20	Ex ia IIC T4 to T6	-	0.3 to 3	6.0/8.0	8017		
4	600	2	-	10	-25	65	NBR	341N3197 ₃₅	2995	496125	2-22	Ex nAc nCc IIC T5/T6	-	1.6	6.0/8.0	8017		

Notes:

1. DC voltage only. Minimum drop off voltage is 15% of nominal voltage (former DIN 19251)
2. With captured exhaust
3. With manual override
4. Pilot seat in FKM
5. Pilot seat in PUR



For this page	Port size	Orifice (mm)	Qn (l/min)	MOPD (bar)	Fluid Temp (°C)	Amb Temp (°C)
From	1/8"-1/4"	4	600	10	-40	-25
To	1/8"-1/4"	4	600	10	80	50

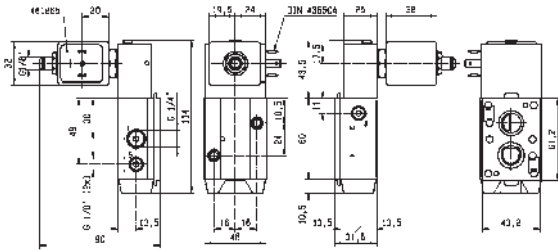

Drawing 7295

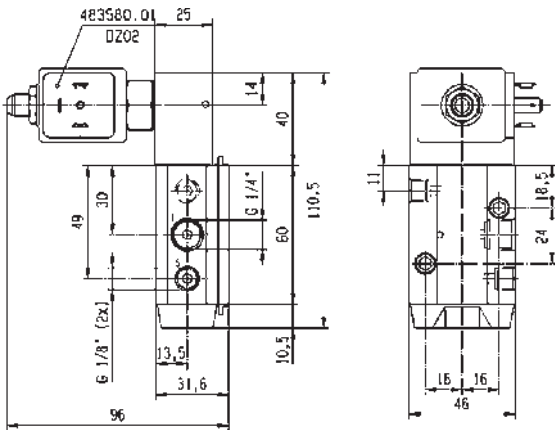

Drawing 7349

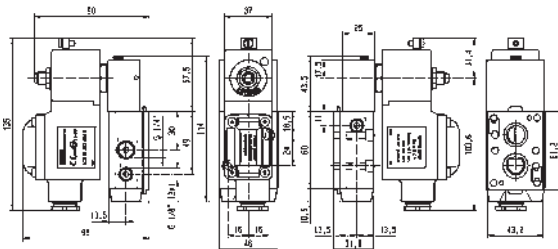

Drawing 8017

3/2-5/2

3 & 5 WAY PNEUMATIC VALVES FOR ACTUATOR CONTROL (NAMUR) PILOT OPERATED

**ANODIZED ALUMINIUM
NAMUR**

SOLENOID OPERATED - SPRING RETURN

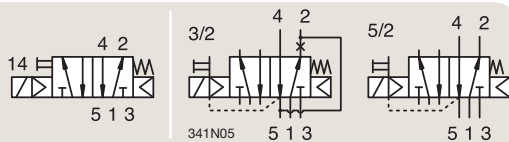

Port size	Orifice Ø	Flow factor	Operating Pressure Differential			Fluid Temp.		Seat Seal	Parker LUCIFER® Valves			ATEX Zone	Protection Mode	Power		Coil Group	Dwg. No.
			1	Min	Max (MOPD)	Min	Max		Valve Ref.	Housing Ref.	Coil Ref.			AC W	DC W		
BSP	mm	Qn l/min	bar	AC bar	DC bar	°C	°C										
1/8" 1/4"	8	1400	2	-	10	-25	55	NBR	341N3290	2995	483580.01	0-20	Ex ia IIC T6	-	0.5 to 3	7.0/8.0	7350
	8	1400	2	-	10	-25	75	NBR	341N3290	-	488660.01	0-20	Ex ia IIC T6	-	0.3 to 3	7.0/8.0	7350
	8	1400	2	-	10	-25	75	NBR	341N3290	-	495910	0-20	Ex ia IIC T4 to T6	-	0.3 to 3	7.0/8.0	7350
	8	1400	2	-	10	-20	80	NBR	341N3296	2995	482740	-	-	-	1.6	6.0/8.0	8029
	8	1400	2	10	10	-20	80	NBR	341N3296	-	495900	1-21	Ex db mb IIC T4 to T6	2.5	2	6.0/8.0	8029
	8	1400	2	-	10	-20	80	NBR	341N3296	-	495910	0-20	Ex ia IIC T4 to T6	-	0.3 to 3	6.0/8.0	8029
	8	1400	2	-	10	-20	80	NBR	341N3296	2995	496125	2-22	Ex nAc nCc IIC T5/T6	-	1.6	6.0/8.0	8029
	8	1400	2	-	10	-20	80	NBR	341N3297 ₁	2995	482740	-	-	-	1.6	6.0/8.0	8029
	8	1400	2	10	10	-20	80	NBR	341N3297 ₁	-	495900	1-21	Ex db mb IIC T4 to T6	2.5	2	6.0/8.0	8029
	8	1400	2	-	10	-20	80	NBR	341N3297 ₁	-	495910	0-20	Ex ia IIC T4 to T6	-	0.3 to 3	6.0/8.0	8029
1/4"	7	1250	2.5	10	10	-10	50	NBR	341N05 ₁	-	496131	-	-	3	3	1.2	8162
	7	1250	2.5	10	10	-10	50	NBR	341N05 ₁	-	496482	-	-	3	3	1.2	8162
	7	1250	2.5	10	10	-10	50	NBR	341N05 ₁	-	496637	22	Ex tc IIIC T95°C	3	3	1.2	8162

Notes:

1. With manual override



For this page	Port size	Orifice (mm)	Qn (l/min)	MOPD (bar)	Fluid Temp (°C)	Amb Temp (°C)
From	1/8"-1/4"	7	1250	10	-25	-25
To	1/4"	8	1400	10	80	50

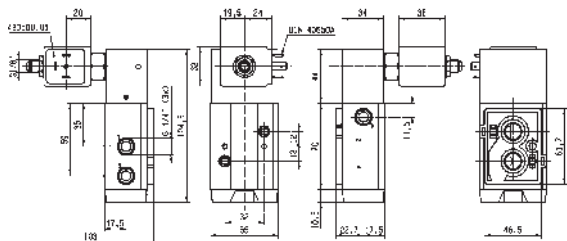

Drawing 7350

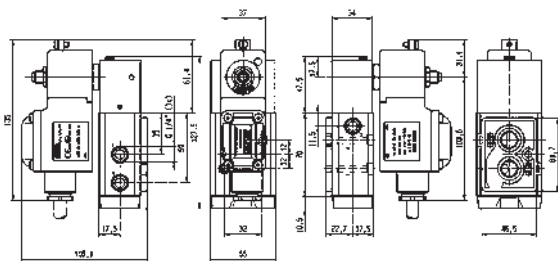

Drawing 8029

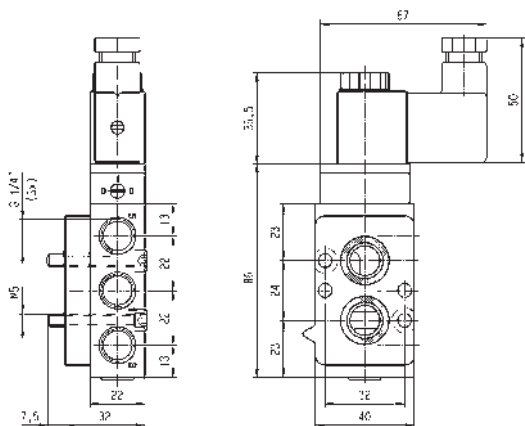

Drawing 8162

3/2-5/2

3 & 5 WAY PNEUMATIC VALVES FOR ACTUATOR CONTROL (NAMUR) PILOT OPERATED

ANODIZED ALUMINIUM
NAMUR

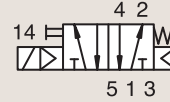

SOLENOID OPERATED - SPRING RETURN

Port size	Orifice Ø	Flow factor	Operating Pressure Differential			Fluid Temp.		Seat Seal	Parker LUCIFER® Valves			ATEX Zone	Protection Mode	Power		Coil Group	Dwg. No.
			Min	Max (MOPD)	Max	Min	Max		Valve Ref.	Housing Ref.	Coil Ref.			AC W	DC W		
BSP	mm	Qn l/min	bar	AC bar	DC bar	°C	°C										
1/4"	7	1200	2.5	10	10	-10	50	NBR	341N0502	-	496131	-	-	3	3	1.2	8253
	7	1200	2.5	10	10	-10	50	NBR	341N0502	-	496482	-	-	3	3	1.2	8253
	7	1200	2.5	10	10	-10	50	NBR	341N35 ₂	2995	481865	-	-	8	9	2.1	8213
	7	1200	2.5	10	10	-10	50	NBR	341N35 ₂	2995	495870	2-22	Ex nAc nCc IIC T3/T4	8	9	2.1	8213
	7	1200	2.5	10	10	-10	50	NBR	341N35 ₂	-	495905	1-21	Ex db mb IIC T4	8	8	2.1	8213
	7	1200	2.5	10	10	-10	50	NBR	341N3502	2995	481865	-	-	8	9	2.1	8254
	7	1200	2.5	10	10	-10	50	NBR	341N3502	4270	481000	-	-	8	8	2.1	8254
	8	1400	2	10	10	-25	80	NBR	341N02 ₁₂	8993	488980	-	-	2	2.5	1.1	7313

Notes:

- 1. With captured exhaust
- 2. With manual override

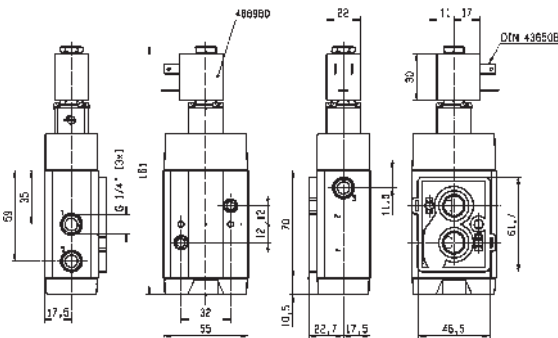

Drawing 7313



For this page	Port size	Orifice (mm)	Qn (l/min)	MOPD (bar)	Fluid Temp (°C)	Amb Temp (°C)
From	1/4"	7	1200	10	-25	-25
To	1/4"	8	1400	10	80	50

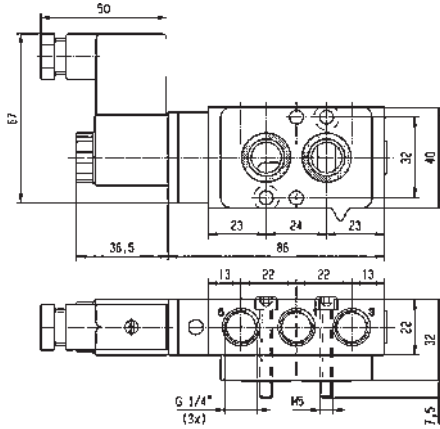

Drawing 8253

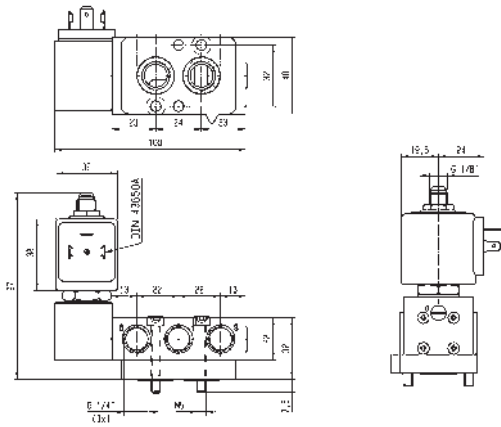

Drawing 8213

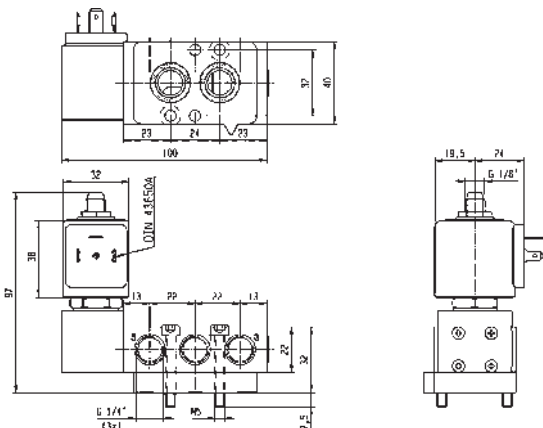

Drawing 8254

3/2-5/2

3 & 5 WAY PNEUMATIC VALVES FOR ACTUATOR CONTROL (NAMUR) PILOT OPERATED

**ANODIZED ALUMINIUM
NAMUR**

SOLENOID OPERATED - SPRING RETURN

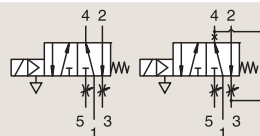

Port size	Orifice Ø	Flow factor	Operating Pressure Differential			Fluid Temp.		Seat Seal	Parker LUCIFER® Valves			ATEX Zone	Protection Mode	Power		Coil Group	Dwg. No.
			Min	Max (MOPD)	DC	Min	Max		Valve Ref.	Housing Ref.	Coil Ref.			AC W	DC W		
BSP	1	Qn l/min	bar	AC bar	DC bar	°C	°C										
1/4"	8	1400	2	10	10	-25	80	NBR	341N12 ₁₂	8993	488980	-	-	2	2.5	1.1	7312
	8	1400	2	10	10	-25	80	NBR	341N22 ₂	2995	481865	-	-	8	9	2.1	7318
	8	1400	2	10	10	-25	80	NBR	341N22 ₂	4270	481000	-	-	8	8	2.1	7318
	8	1400	2	10	10	-25	80	NBR	341N32 ₂	2995	481865	-	-	8	9	2.1	7317
	8	1400	2	10	10	-25	80	NBR	341N32 ₂	2995	495870	2-22	Ex nAc nCc IIC T3/T4	8	9	2.1	7317
	8	1400	2	10	10	-25	80	NBR	341N32 ₂	-	495905	1-21	Ex db mb IIC T4	8	8	2.1	7317
	8	1400	2	10	10	-25	80	NBR	341N3202	2995	481865	-	-	8	9	2.1	7317
	8	1400	2	10	10	-25	80	NBR	341N3202	2995	495870	2-22	Ex nAc nCc IIC T3/T4	8	9	2.1	7317
8	1400	2	10	10	-25	80	NBR	341N3202	-	495905	1-21	Ex db mb IIC T4	8	8	2.1	7317	

Notes:

- 1. With captured exhaust
- 2. With manual override



For this page	Port size	Orifice (mm)	Qn (l/min)	MOPD (bar)	Fluid Temp (°C)	Amb Temp (°C)
From	1/4"	8	1400	10	-25	-25
To	1/4"	8	1400	10	80	50

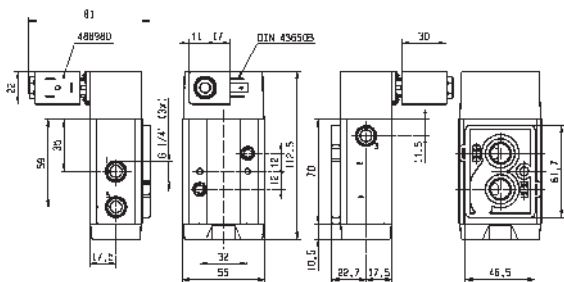

Drawing 7312

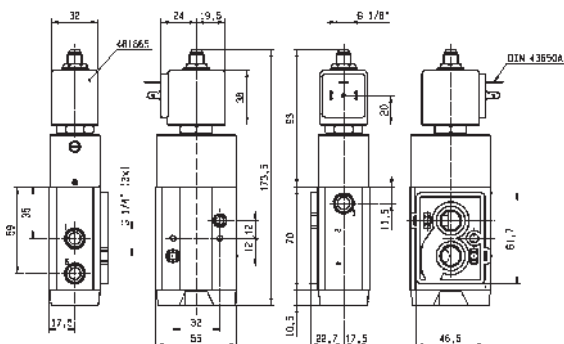

Drawing 7318

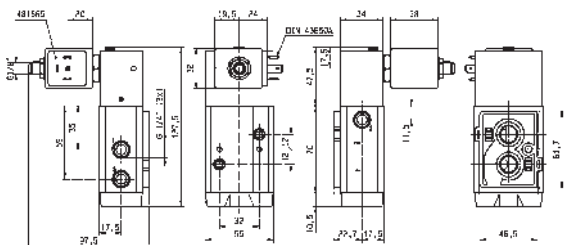

Drawing 7317

5/2

3 & 5 WAY PNEUMATIC VALVES FOR ACTUATOR CONTROL (NAMUR) PILOT OPERATED

ANODIZED ALUMINIUM
NAMUR

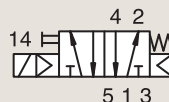

SOLENOID OPERATED - SPRING RETURN

Port size	Orifice Ø	Flow factor	Operating Pressure Differential			Fluid Temp.		Seat Seal	Parker LUCIFER® Valves			ATEX Zone	Protection Mode	Power		Coil Group	Dwg. No.
			Min	Max (MOPD)	DC	Min	Max		Valve Ref.	Housing Ref.	Coil Ref.			AC W	DC W		
1/4"	7	1250	2.5	10	10	-10	50	NBR	341N03 ₁	-	496131	-	-	3	3	1.2	8063
	7	1250	2.5	10	10	-10	50	NBR	341N03 ₁	-	496482	-	-	3	3	1.2	8063
	7	1250	2.5	10	10	-10	50	NBR	341N03 ₁	-	496637	22	Ex tc IIIC T95°C	3	3	1.2	8063
1/2"	12	3000	2.5	10	10	-10	50	NBR	341N04 ₁	-	496131	-	-	3	3	1.2	8065
	12	3000	2.5	10	10	-10	50	NBR	341N04 ₁	-	496482	-	-	3	3	1.2	8065
	12	3000	2.5	10	10	-10	50	NBR	341N04 ₁	-	496637	22	Ex tc IIIC T95°C	3	3	1.2	8065
	12	3000	2.5	10	10	-10	50	NBR	341N34 ₁₂	2995	481865	-	-	8	9	2.1	8211
	12	3000	2.5	10	10	-10	50	NBR	341N34 ₁₂	2995	495870	2-22	Ex nAc nCc IIC T3/T4	8	9	2.1	8211
	12	3000	2.5	10	10	-10	50	NBR	341N34 ₁₂	-	495905	1-21	Ex db mb IIC T4	8	8	2.1	8211

Notes:

1. With manual override
2. Pilot seat in FKM



For this page	Port size	Orifice (mm)	Qn (l/min)	MOPD (bar)	Fluid Temp (°C)	Amb Temp (°C)
From	1/4"	7	1250	10	-10	-10
To	1/2"	12	3000	10	50	50

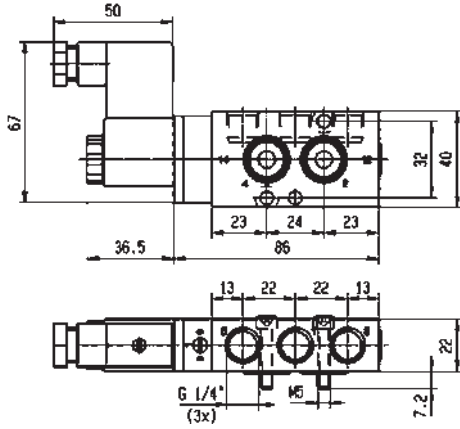

Drawing 8063

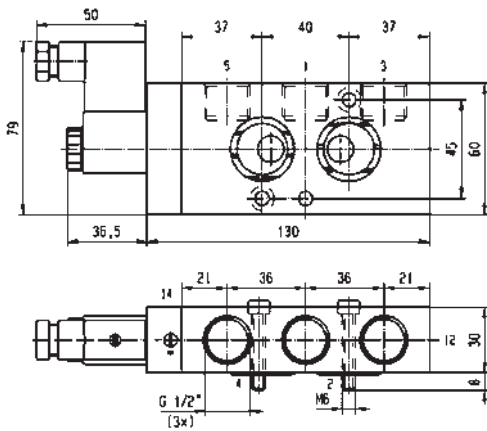

Drawing 8065

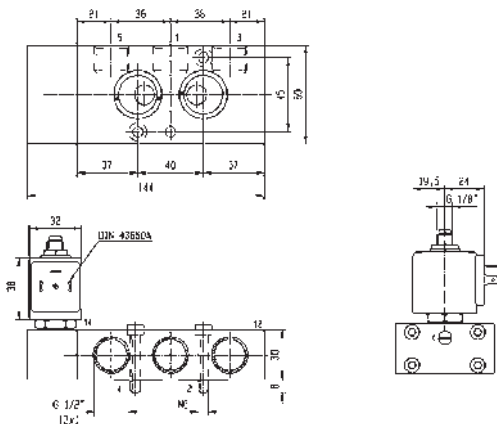

Drawing 8211

5/2

3 & 5 WAY PNEUMATIC VALVES FOR ACTUATOR CONTROL (NAMUR) PILOT OPERATED

ANODIZED ALUMINIUM
NAMUR

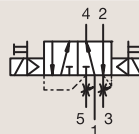

DUAL SOLENOIDS

Port size	Orifice Ø	Flow factor	Operating Pressure Differential			Fluid Temp.		Seat Seal	Parker LUCIFER® Valves			ATEX Zone	Protection Mode	Power		Coil Group	Dwg. No.
			Min	Max (MOPD)	DC	Min	Max		Valve Ref.	Housing Ref.	Coil Ref.			AC W	DC W		
BSP	1	Qn l/min	bar	AC bar	DC bar	°C	°C										
1/8"- 1/4"	4	400	2	10	10	-25	50	NBR	347N11 ¹²³	-	482606	1-21	Ex mb IIC T4/T5	2	2.5	1.1	7305
	4	400	2	10	10	-25	80	NBR	347N11 ¹²³	8993	488980	-	-	2	2.5	1.1	7305
	4	400	2	10	10	-25	80	NBR	347N31 ²³	2995	481865	-	-	8	9	2.1	7297
	4	400	2	10	10	-25	80	NBR	347N31 ²³	2995	495870	2-22	Ex nAc nCc IIC T3/T4	8	9	2.1	7297
	4	400	2	10	10	-25	80	NBR	347N31 ²³	-	495905	1-21	Ex db mb IIC T4	8	8	2.1	7297
	4	400	2	-	10	-25	55	NBR	347N3190 ³	2995	483580.01	0-20	Ex ia IIC T6	-	0.5 to 3	7.0/8.0	8141
	4	400	2	-	10	-25	65	NBR	347N3197 ²⁴	2995	482740	-	-	-	1.6	3.0/6.0/8.0	7297
	4	400	2	10	10	-25	65	NBR	347N3197 ²⁴	-	495900	1-21	Ex db mb IIC T4 to T6	2.5	2	3.0/6.0/8.0	7297
	4	400	2	-	10	-25	65	NBR	347N3197 ²⁴	-	495910	0-20	Ex ia IIC T4 to T6	-	0.3 to 3	3.0/6.0/8.0	7297
	4	400	2	-	10	-25	65	NBR	347N3197 ²⁴	2995	496125	2-22	Ex nAc nCc IIC T5/T6	-	1.6	3.0/6.0/8.0	7297

Notes:

1. With captured exhaust
2. With manual override
3. Pilot seat in FKM
4. Pilot seat in PUR



For this page	Port size	Orifice (mm)	Qn (l/min)	MOPD (bar)	Fluid Temp (°C)	Amb Temp (°C)
From	1/8"-1/4"	4	400	10	-25	-25
To	1/8"-1/4"	4	400	10	80	50

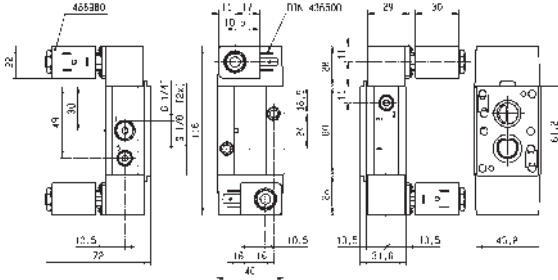

Drawing 7305

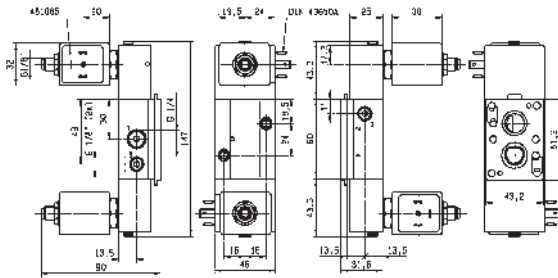

Drawing 7297

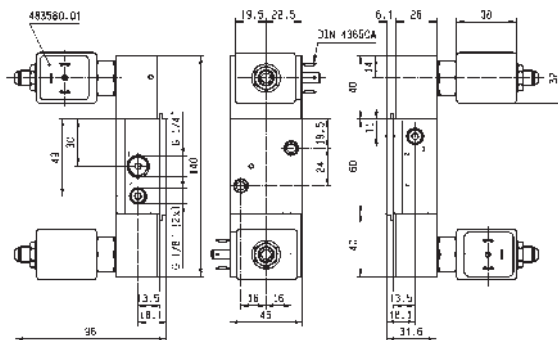

Drawing 8141

5/2

3 & 5 WAY PNEUMATIC VALVES FOR ACTUATOR CONTROL (NAMUR) PILOT OPERATED

ANODIZED ALUMINIUM
NAMUR

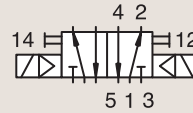

DUAL SOLENOIDS

Port size	Orifice Ø	Flow factor	Operating Pressure Differential			Fluid Temp.		Seat Seal	Parker LUCIFER® Valves			ATEX Zone	Protection Mode		Power		Coil Group	Dwg. No.
			1	Min	Max (MOPD)	Min	Max		Valve Ref.	Housing Ref.	Coil Ref.		AC W	DC W				
															Qn l/min	AC bar		
1/4"	7	1250	2.5	10	10	-10	50	NBR	347N03 ₂	-	496131	-	-	3	3	1.2	8057	
	7	1250	2.5	10	10	-10	50	NBR	347N03 ₂	-	496482	-	-	3	3	1.2	8057	
	7	1250	2.5	10	10	-10	50	NBR	347N03 ₂	-	496637	22	Ex tc IIC T95°C	3	3	1.2	8057	
	7	1250	2.5	10	10	-10	50	NBR	347N33 ₃	2995	481865	-	-	8	9	2.1	8209	
	7	1250	2.5	10	10	-10	50	NBR	347N33 ₃	2995	495870	2-22	Ex nAc nCc IIC T3/T4	8	9	2.1	8209	
	7	1250	2.5	10	10	-10	50	NBR	347N33 ₃	-	495905	1-21	Ex db mb IIC T4	8	8	2.1	8209	
	8	1400	2	10	10	-10	65	NBR	347N12 ₁₂	-	482606	1-21	Ex mb IIC T4/T5	2	2.5	1.1	7315	
	8	1400	2	10	10	-25	80	NBR	347N12 ₁₂	8993	488980	-	-	2	2.5	1.1	7315	
	8	1400	2	10	10	-25	80	NBR	347N32 ₂₃	2995	481865	-	-	8	9	2.1	7320	
	8	1400	2	10	10	-25	80	NBR	347N32 ₂₃	2995	495870	2-22	Ex nAc nCc IIC T3/T4	8	9	2.1	7320	
8	1400	2	10	10	-25	80	NBR	347N32 ₂₃	-	495905	1-21	Ex db mb IIC T4	8	8	2.1	7320		

Notes:

1. With captured exhaust
2. With manual override
3. Pilot seat in FKM

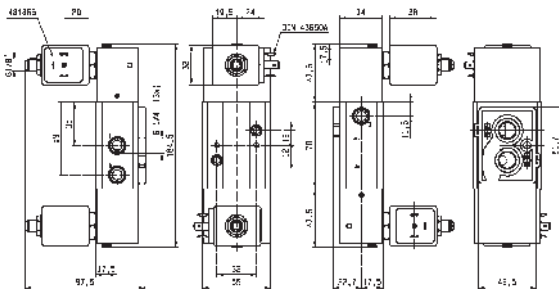

Drawing 7320



For this page	Port size	Orifice (mm)	Qn (l/min)	MOPD (bar)	Fluid Temp (°C)	Amb Temp (°C)
From	1/4"	7	1250	10	-25	-25
To	1/4"	8	1400	10	120	50

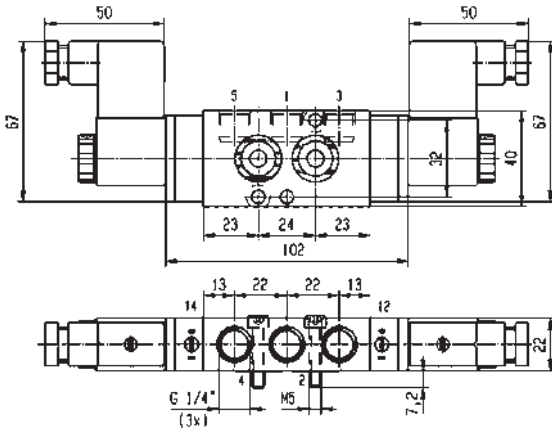

Drawing 8057

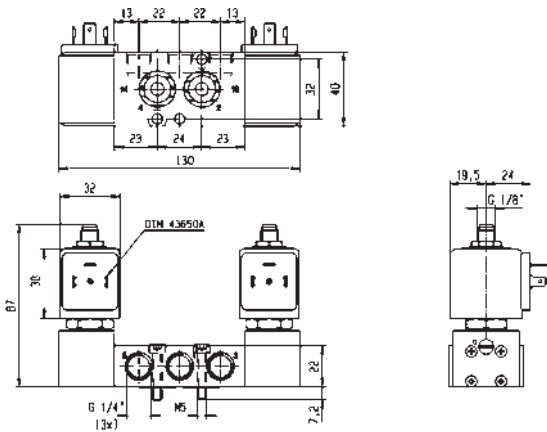

Drawing 8209

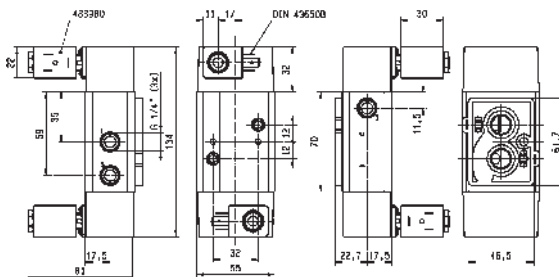

Drawing 7315

5/2

3 & 5 WAY PNEUMATIC VALVES FOR ACTUATOR CONTROL (NAMUR) PILOT OPERATED

ANODIZED ALUMINIUM

NAMUR

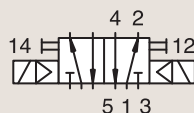

DUAL SOLENOIDS

Port size	Orifice Ø	Flow factor	Operating Pressure Differential			Fluid Temp.		Seat Seal	Parker LUCIFER® Valves			ATEX Zone	Protection Mode	Power		Coil Group	Dwg. No.
			Min	Max (MOPD)		Min	Max		Valve Ref.	Housing Ref.	Coil Ref.			AC W	DC W		
BSP	1	Qn	bar	AC bar	DC bar	°C	°C										
1/2"	12	3000	2.5	10	10	-10	50	NBR	347N04 ₁	-	496131	-	-	3	3	1.2	8154
	12	3000	2.5	10	10	-10	50	NBR	347N04 ₁	-	496482	-	-	3	3	1.2	8154
	12	3000	2.5	10	10	-10	50	NBR	347N04 ₁	-	496637	22	Ex tc IIC T95°C	3	3	1.2	8154
	12	3000	2.5	10	10	-10	50	NBR	347N34 ₁₂	2995	481865	-	-	8	9	2.1	8212
	12	3000	2.5	10	10	-10	50	NBR	347N34 ₁₂	2995	495870	2-22	Ex nAc nCc IIC T3/T4	8	9	2.1	8212
	12	3000	2.5	10	10	-10	50	NBR	347N34 ₁₂	-	495905	1-21	Ex db mb IIC T4	8	8	2.1	8212

Notes:

- 1. With manual override
- 2. Pilot seat in FKM



For this page	Port size	Orifice (mm)	Qn (l/min)	MOPD (bar)	Fluid Temp (°C)	Amb Temp (°C)
From	1/2"	12	3000	10	-10	-10
To	1/2"	12	3000	10	120	50

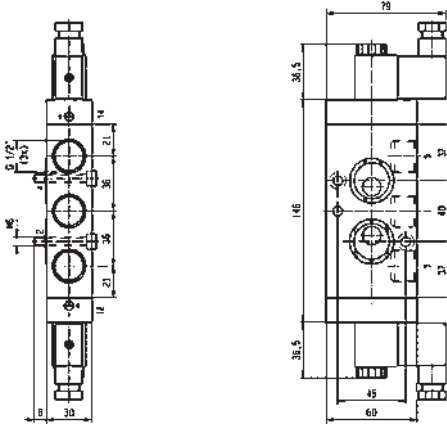

Drawing 8154

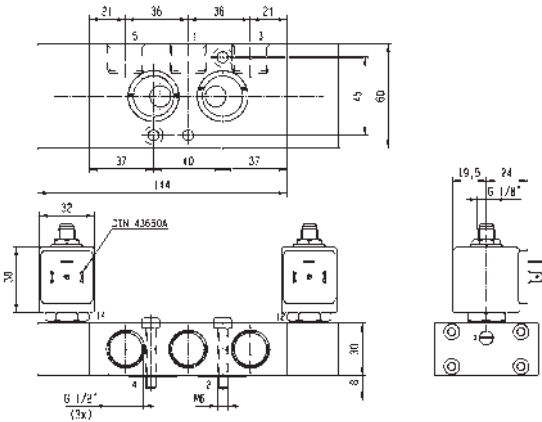

Drawing 8212

5/3

3 & 5 WAY PNEUMATIC VALVES FOR ACTUATOR CONTROL (NAMUR) PILOT OPERATED

ANODIZED ALUMINIUM
NAMUR

W1 CLOSED CENTER POSITION

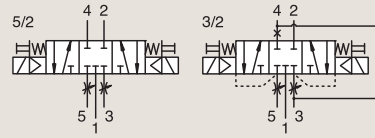

Port size	Orifice Ø	Flow factor	Operating Pressure Differential			Fluid Temp.		Seat Seal	Parker LUCIFER® Valves			ATEX Zone	Protection Mode	Power		Coil Group	Dwg. No.
			Min	Max (MOPD)	Max (MOPD)	Min	Max		Valve Ref.	Housing Ref.	Coil Ref.			AC W	DC W		
1/8"-1/4"	4	400	2	10	10	-25	80	NBR	342N11 ₁₂	-	482606	1-21	Ex mb IIC T4/T5	2	2.5	1.1	7305
	4	400	2	10	10	-25	80	NBR	342N11 ₁₂	8993	488980	-	-	2	2.5	1.1	7305
1/4"	4	400	2	-	10	-10	65	NBR	342N3197 ₂	-	495910	0-20	Ex ia IIC T4 to T6	-	0.3 to 3	6.0/8.0	7297
	7	1250	3	10	10	-10	50	NBR	342N03 ₂	-	496131	-	-	3	3	1.2	8057
	7	1250	3	10	10	-10	50	NBR	342N03 ₂	-	496482	-	-	3	3	1.2	8057
	7	1250	3	10	10	-10	50	NBR	342N03 ₂	-	496637	22	Ex tc IIIC T95°C	3	3	1.2	8057
	7	1250	2.5	10	10	-10	50	NBR	342N33 ₂	2995	481865	-	-	8	9	2.1	8209
	7	1250	2.5	10	10	-10	50	NBR	342N33 ₂	2995	495870	2-22	Ex nAc nCc IIC T3/T4	8	9	2.1	8209
7	1250	2.5	10	10	-10	50	NBR	342N33 ₂	-	495905	1-21	Ex db mb IIC T4	8	8	2.1	8209	

Notes:

1. With captured exhaust
2. With manual override

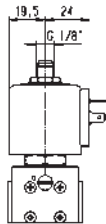
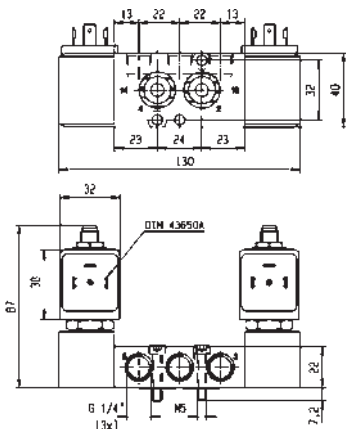

Drawing 8209



For this page	Port size	Orifice (mm)	Qn (l/min)	MOPD (bar)	Fluid Temp (°C)	Amb Temp (°C)
From	1/8"-1/4"	4	400	10	-25	-25
To	1/4"	7	1250	10	120	50

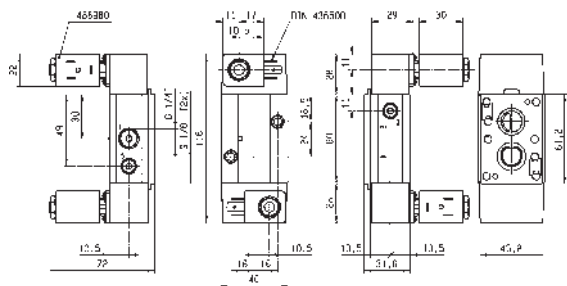

Drawing 7305

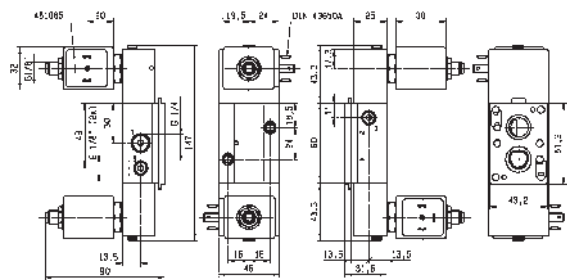

Drawing 7297

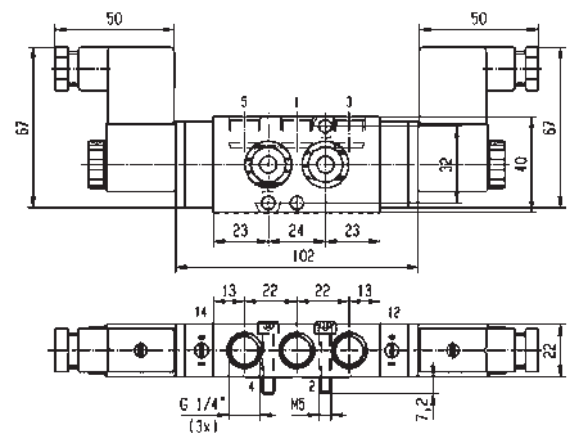

Drawing 8057

5/3

3 & 5 WAY PNEUMATIC VALVES FOR ACTUATOR CONTROL (NAMUR) PILOT OPERATED

ANODIZED ALUMINIUM
NAMUR

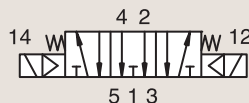

W3 EXHAUSTED IN CENTER POSITION

Port size	Orifice Ø	Flow factor	Operating Pressure Differential			Fluid Temp.		Seat Seal	Parker LUCIFER® Valves			ATEX Zone	Protection Mode	Power		Coil Group	Dwg. No.
			Min	Max (MOPD)		Min	Max		Valve Ref.	Housing Ref.	Coil Ref.			AC W	DC W		
BSP	1	Qn l/min	bar	AC bar	DC bar	°C	°C										
	7	1250	2.5	10	10	-10	50	NBR	343N03 ₁	-	496131	-	-	3	3	1.2	8057
1/4"	7	1250	2.5	10	10	-10	50	NBR	343N03 ₁	-	496482	-	-	3	3	1.2	8057
	7	1250	2.5	10	10	-10	50	NBR	343N03 ₁	-	496637	22	Ex tc IIIC T95°C	3	3	1.2	8057

Notes:

1. With manual override



For this page	Port size	Orifice (mm)	Qn (l/min)	MOPD (bar)	Fluid Temp (°C)	Amb Temp (°C)
From	1/4"	7	1250	10	-10	-10
To	1/4"	7	1250	10	50	50

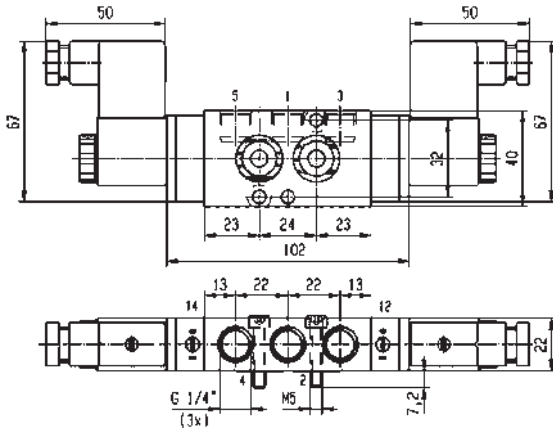

Drawing 8057

3/2-5/2

3 & 5 WAY PNEUMATIC VALVES FOR ACTUATOR CONTROL (NAMUR) PILOT OPERATED

**ANODIZED ALUMINIUM
NAMUR**

CONTROL BY ELECTRIC IMPULSE

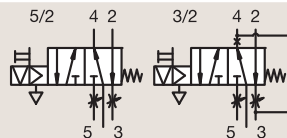

Port size	Orifice Ø	Flow factor	Operating Pressure Differential			Fluid Temp.		Seat Seal	Parker LUCIFER® Valves			ATEX Zone	Protection Mode	Power		Coil Group	Dwg. No.
			Min	Max (MOPD)	DC bar	Min	Max		Valve Ref.	Housing Ref.	Coil Ref.			AC W	DC W		
1/8"	4	600	2	-	10	-25	80	FKM/NBR	345N31 ₁₂	4269	485400	-	-	-	13	4.0	7295

Notes:

- 1. Pilot seat in FKM
- 2. With manual override

**ANODIZED ALUMINIUM
NAMUR**

SOLENOID OPERATED - SPRING RETURN

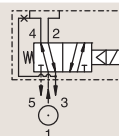

Port size	Orifice Ø	Flow factor	Operating Pressure Differential			Fluid Temp.		Seat Seal	Parker LUCIFER® Valves			ATEX Zone	Protection Mode	Power		Coil Group	Dwg. No.
			Min	Max (MOPD)	DC bar	Min	Max		Valve Ref.	Housing Ref.	Coil Ref.			AC W	DC W		
1/8" 1/4"	4	355	1	10	10	-10	75	NBR	341L9504 ₁₂	-	482605	1-21	Ex mb IIC T4/T5	4	5	1.1	7009
	4	355	1	10	10	-10	75	NBR	341L9504 ₁₂	-	482606	1-21	Ex mb IIC T4/T5	2	2.5	1.1	7009
	4	355	1	10	10	-10	75	NBR	341L9504 ₁₂	8993	488980	-	-	2	2.5	1.1	7009
	4	355	1	10	10	-10	75	NBR	341L9504 ₁₂	8993	495865	2-22	Ex nAc nCc IIC T5	2	2.5	1.1	7009
	4	355	1	10	10	-10	75	NBR	341L9534 ₁₂	2995	481865	-	-	8	9	2.1/7.0	3990
	4	355	1	10	10	-10	75	NBR	341L9534 ₁₂	2995	495870	2-22	Ex nAc nCc IIC T3/T4	8	9	2.1/7.0	3990
	4	355	1	10	10	-10	75	NBR	341L9534 ₁₂	-	495905	1-21	Ex db mb IIC T4	8	8	2.1/7.0	3990

Notes:

- 1. Pilot seat in FKM
- 2. With manual override



For this page	Port size	Orifice (mm)	Qn (l/min)	MOPD (bar)	Fluid Temp (°C)	Amb Temp (°C)
From	1/8"-1/4"	4	355	10	-25	-25
To	1/8"-1/4"	4	600	10	80	50

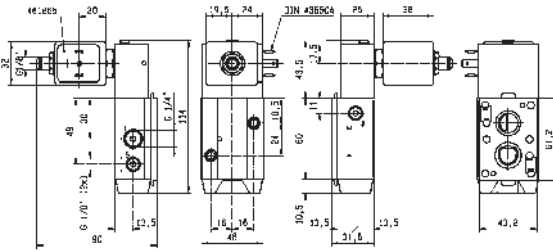

Drawing 7295

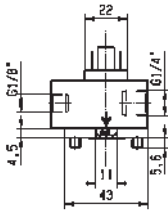

Weight : 310 gr

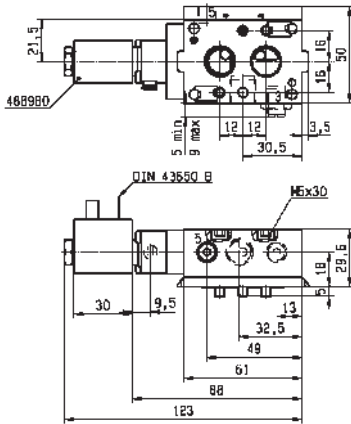

Drawing 7009

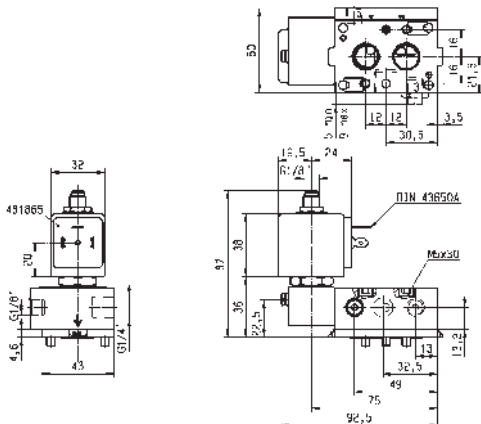

Drawing 3990

3/2-5/2

3 & 5 WAY PNEUMATIC VALVES
FOR ACTUATOR CONTROL (NAMUR)
PILOT OPERATED

ANODIZED ALUMINIUM
NAMUR

SOLENOID OPERATED - SPRING RETURN

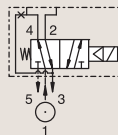

Port size	Orifice Ø	Flow factor	Operating Pressure Differential			Fluid Temp.		Seat Seal	Parker LUCIFER® Valves			ATEX Zone	Protection Mode	Power		Coil Group	Dwg. No.
			Min	Max (MOPD)	AC bar	DC bar	Min		Max	Valve Ref.	Housing Ref.			Coil Ref.	AC W		
BSP	1	Qn l/min	bar	AC bar	DC bar	°C	°C										
1/8" 1/4"	4	355	2	-	10	-10	55	NBR	341L9594 ₁₂	2995	483580.01	0-20	Ex ia IIC T6	-	0.5 to 3	7.0	3992
	4	355	1	-	10	-10	75	NBR	341L9594 ₁₂	-	495910	0-20	Ex ia IIC T4 to T6	-	0.3 to 3	7.0	3992
	4	355	2	-	10	-10	75	NBR	341L9597 ₂₃	2995	482740	-	-	-	1.6	6.0/8.0	8025
	4	355	2	10	10	-10	75	NBR	341L9597 ₂₃	-	495900	1-21	Ex db mb IIC T4 to T6	2.5	2	6.0/8.0	8025
	4	355	2	-	10	-10	75	NBR	341L9597 ₂₃	-	495910	0-20	Ex ia IIC T4 to T6	-	0.3 to 3	6.0/8.0	8025
	4	355	2	-	10	-10	75	NBR	341L9597 ₂₃	2995	496125	2-22	Ex nAc nCc IIC T5/T6	-	1.6	6.0/8.0	8025
	4	355	2	-	10	-25	55	NBR	341L9598 ₃	2995	483580.01	0-20	Ex ia IIC T6	-	0.5 to 3	7.0	3992

Notes:

1. Pilot seat in FKM
2. With manual override
3. Pilot seat in PUR



For this page	Port size	Orifice (mm)	Qn (l/min)	MOPD (bar)	Fluid Temp (°C)	Amb Temp (°C)
From	1/8"-1/4"	4	355	10	-25	-10
To	1/8"-1/4"	4	355	10	75	50

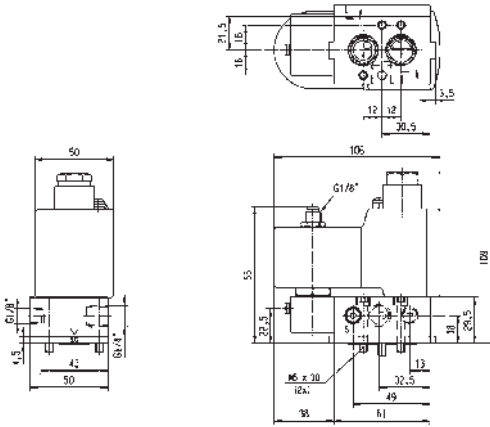

Drawing 3992

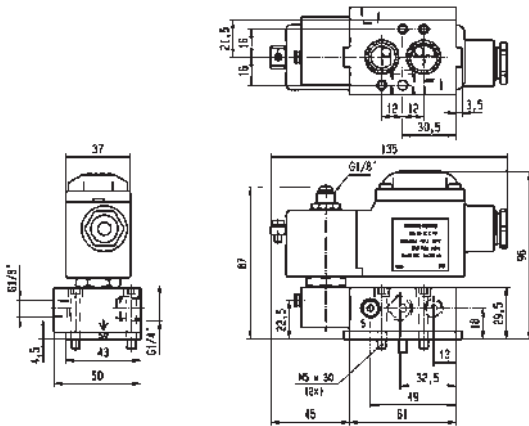

Drawing 8025

3/2

3 & 5 WAY PNEUMATIC VALVES FOR ACTUATOR CONTROL (NAMUR) EXTERNALLY OPERATED



Process

ANODIZED ALUMINIUM NAMUR

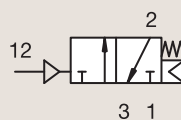

AIR OPERATED - SPRING RETURN

Port size	Orifice Ø 1	Flow factor Qn l/min	Operating Pressure Differential			Fluid Temp.		Seat Seal	Parker LUCIFER® Valves			ATEX Zone	Protection Mode	Power		Coil Group	Dwg. No.
			Min	Max (MOPD)	DC	Min	Max		Valve Ref.	Housing Ref.	Coil Ref.			AC W	DC W		
1/4"	7	1250	2.5	10	10	-10	50	NBR	531N03	-	-	-	-	-	-	-	8058
1/2"	12	3000	2.5	10	10	-10	50	NBR	531N04	-	-	-	-	-	-	-	8061



For this page	Port size	Orifice (mm)	Qn (l/min)	MOPD (bar)	Fluid Temp (°C)	Amb Temp (°C)
From	1/4"	7	1250	10	-10	-10
To	1/2"	12	3000	10	50	50

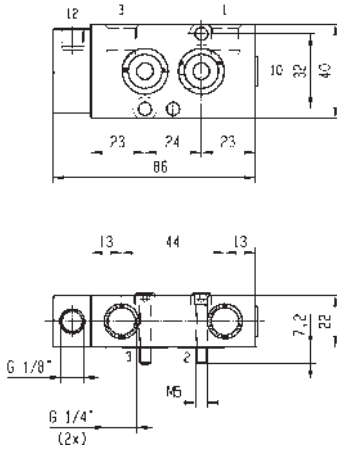

Drawing 8058

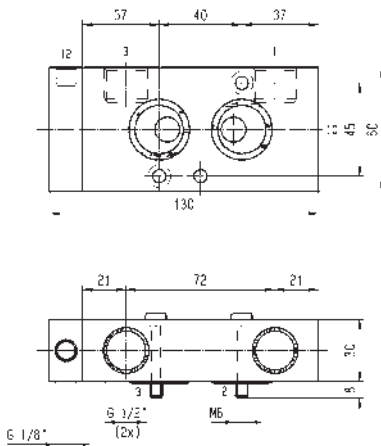

Drawing 8061

3/2-5/2

3 & 5 WAY PNEUMATIC VALVES FOR ACTUATOR CONTROL (NAMUR) EXTERNALLY OPERATED

ANODIZED ALUMINIUM

NAMUR

AIR OPERATED - SPRING RETURN

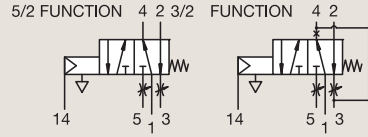

Port size	Orifice Ø 1	Flow factor Qn l/min	Operating Pressure Differential			Fluid Temp.		Seat Seal	Parker LUCIFER® Valves			ATEX Zone	Protection Mode	Power		Coil Group	Dwg. No.
			Min	Max (MOPD)	AC bar	DC bar	Min		Max	Valve Ref.	Housing Ref.			Coil Ref.	AC W		
BSP	mm		bar	bar	bar	°C	°C										
1/8"-1/4"	4	600	2	10	10	-25	80	NBR	541N01	-	-	-	-	-	-	-	7309
	4	600	2	10	10	-40	50	NBR	541N0108	-	-	-	-	-	-	-	7309



For this page	Port size	Orifice (mm)	Qn (l/min)	MOPD (bar)	Fluid Temp (°C)	Amb Temp (°C)
From	1/8"-1/4"	4	600	10	-40	-40
To	1/8"-1/4"	4	600	10	80	50

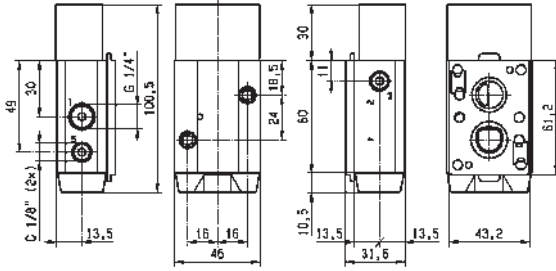

Drawing 7309

5/2

3 & 5 WAY PNEUMATIC VALVES FOR ACTUATOR CONTROL (NAMUR) EXTERNALLY OPERATED

**ANODIZED ALUMINIUM
NAMUR**

5/2 FUNCTION

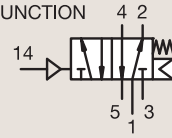

AIR OPERATED - SPRING RETURN

Port size	Orifice Ø	Flow factor	Operating Pressure Differential			Fluid Temp.		Seat Seal	Parker LUCIFER® Valves			ATEX Zone	Protection Mode	Power		Coil Group	Dwg. No.
			Min	Max (MOPD)	DC bar	Min	Max		Valve Ref.	Housing Ref.	Coil Ref.			AC W	DC W		
BSP	1	Qn l/min	bar	AC bar	DC bar	°C	°C										
1/4"	7	1250	2.5	10	10	-10	50	NBR	541N03	-	-	-	-	-	-	-	8064
1/2"	12	3000	2.5	10	10	-10	50	NBR	541N04	-	-	-	-	-	-	-	8066

**ANODIZED ALUMINIUM
NAMUR**

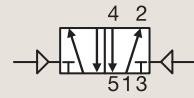

AIR OPERATED AND RETURN

Port size	Orifice Ø	Flow factor	Operating Pressure Differential			Fluid Temp.		Seat Seal	Parker LUCIFER® Valves			ATEX Zone	Protection Mode	Power		Coil Group	Dwg. No.
			Min	Max (MOPD)	DC bar	Min	Max		Valve Ref.	Housing Ref.	Coil Ref.			AC W	DC W		
BSP	1	Qn l/min	bar	AC bar	DC bar	°C	°C										
1/4"	7	1250	2.5	10	10	-10	50	NBR	547N03	-	-	-	-	-	-	-	8059



For this page	Port size	Orifice (mm)	Qn (l/min)	MOPD (bar)	Fluid Temp (°C)	Amb Temp (°C)
From	1/4"	7	1250	10	-10	-10
To	1/2"	12	3000	10	50	50

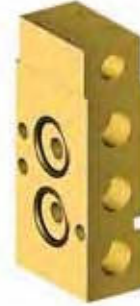
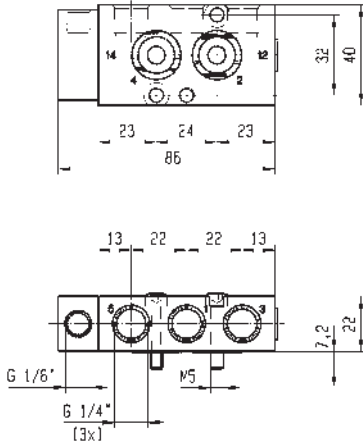

Drawing 8064

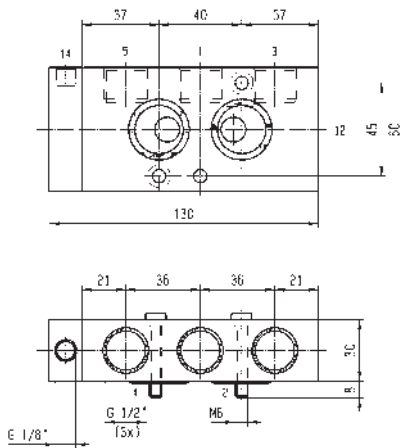

Drawing 8066

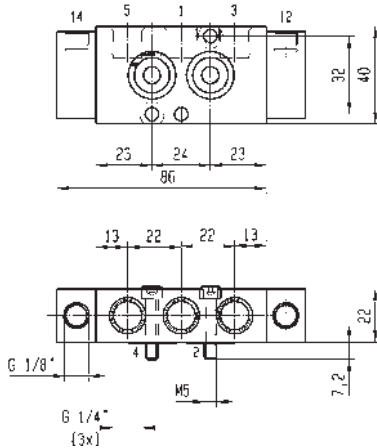

Drawing 8059

5/3

3 & 5 WAY PNEUMATIC VALVES FOR ACTUATOR CONTROL (NAMUR) EXTERNALLY OPERATED

**ANODIZED ALUMINIUM
NAMUR**

W1 CLOSED CENTER POSITION

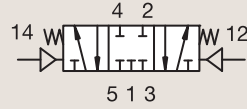

Port size	Orifice Ø	Flow factor	Operating Pressure Differential			Fluid Temp.		Seat Seal	Parker LUCIFER® Valves			ATEX Zone	Protection Mode	Power		Coil Group	Dwg. No.
			Min	Max (MOPD)	AC	DC	Min		Max	Valve Ref.	Housing Ref.			Coil Ref.	AC W		
BSP	mm	Qn l/min	bar	bar	bar	°C	°C										
1/4"	7	1250	2.5	10	10	-10	50	NBR	542N03	-	-	-	-	-	-	-	8059



For this page	Port size	Orifice (mm)	Qn (l/min)	MOPD (bar)	Fluid Temp (°C)	Amb Temp (°C)
From	1/4"	7	1250	10	-10	-10
To	1/4"	7	1250	10	50	50

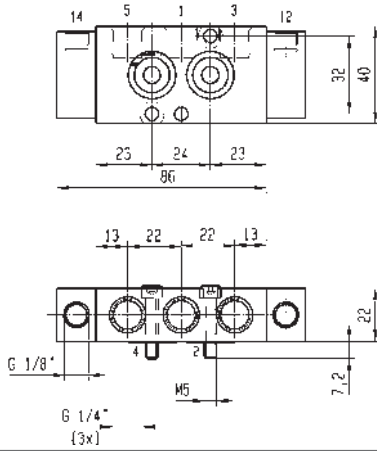

Drawing 8059



316L STAINLESS STEEL 3 & 5 WAY VALVES FOR ACTUATOR CONTROL (PIPE MOUNTING AND NAMUR)



3/2
5/2

Actuation	Body	Function	Port Size	Orifice (mm)	Qn (l/min)	MOPD (bar)	Max Fluid Temp. (°C)	Page Parker Valves	Page Parker LUCIFER® Valves
Direct Operated	316L Stainless St./Pipe mounting	Universal	1/4"	2 to 6	680	12	80	-	376
			3/8"	6	680	10	75	-	382
	316L Stainless St./Sub-base mounting	Normally Closed	5 mm	2.5	220	14	80	-	384
		Universal	6 mm	2.5	220	10	75	-	384
	316L Stainless St./NAMUR	Normally Closed	1/4"	6	680	10	65	-	384
Pilot Operated	316L Stainless St./Pipe mounting	Normally Closed	3/8"	8	1400	10	80	-	388
	316L Stainless St./Pipe mounting/Spool	Normally Closed	3/8"	8	1400	10	80	-	388
		Dual Solenoids	3/8"	8	1400	10	80	-	392
	316L Stainless St./NAMUR/Spool	Normally Closed	3/8"-1/4"	8	1400	10	80	-	394
		Solenoid operated - spring return	3/8"-1/4"	8	1400	10	80	-	394
		Dual Solenoids	3/8"-1/4"	8	1400	10	80	-	398
Manual Reset	316L Stainless St./Pipe mounting	Universal	1/4"	6	680	10	75	-	400
			3/8"	6	680	10	65	-	404

3/2

316L STAINLESS STEEL 3 & 5 WAY VALVES FOR ACTUATOR CONTROL (PIPE MOUNTING AND NAMUR) DIRECT OPERATED



Process

316L STAINLESS ST. PIPE MOUNTING

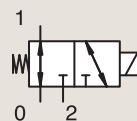

UNIVERSAL

Port size	Orifice Ø 1	Flow factor Qn l/min	Operating Pressure Differential			Fluid Temp.		Seat Seal	Parker LUCIFER® Valves			ATEX Zone	Protection Mode	Power		Coil Group	Dwg. No.
			Min	Max (MOPD)	DC	Min	Max		Valve Ref.	Housing Ref.	Coil Ref.			AC W	DC W		
1/4" NPT	2	140	0	12	12	-25	65	FKM	U133V5595 ₁	-	492310	1-21	Ex eb mb II T3 to T6	6	6	9.0/10.1	6713
	2	140	0	-	12	-25	75	FKM	U133V5595 ₁	-	492965.01	0-20	Ex ia IIC T6	-	0.3 to 3	9.0/10.1	6713
	2	140	0	12	12	-25	65	FKM	U133V5595 ₁	-	496800	1-21	Ex db mb IIC T4	8	8	9.0/10.1	6713
	2	140	0	12	12	-25	80	FKM	U133V55951D ₁	-	483270.02	1-21	Ex db IIC T4 to T6	8	8	11.0	6714
	2	140	0	12	12	-25	65	FKM	U133V7595	-	492310	1-21	Ex eb mb II T3 to T6	6	6	9.0/10.1	8166
	2	140	0	-	12	-25	60	FKM	U133V7595	-	492965.01	0-20	Ex ia IIC T6	-	0.3 to 3	9.0/10.1	8166
	2	140	0	-	12	-25	65	FKM	U133V7595	-	496565	0-20	Ex ia IIC T4 to T6	-	0.3	9.0/10.1	8166
	2.5	220	0	-	8.5	-25	75	FKM	U133V5695 ₁	-	492210	1-21	Ex eb mb IIC T5/T6	-	1.8	9.0/10.1	6713
	2.5	220	0	-	8.5	-25	75	FKM	U133V5695 ₁	-	492965.01	0-20	Ex ia IIC T6	-	1.8	9.0/10.1	6713
	2.5	220	0	8.5	8.5	-25	75	FKM	U133V5695 ₁	-	496800	1-21	Ex db mb IIC T4	8	8	9.0/10.1	6713
	2.5	220	0	8.5	8.5	-10	75	FKM	U133V56951D ₁₂	-	483270.02	1-21	Ex db IIC T4 to T6	8	8	11.0	6714
	2.5	220	0	8.5	8.5	-25	75	FKM	U133V7695	-	492310	1-21	Ex eb mb II T3 to T6	6	6	9.0/10.1	8166
	2.5	220	0	-	8.5	-25	65	FKM	U133V7695	-	492965.01	0-20	Ex ia IIC T6	-	0.3 to 3	9.0/10.1	8166
	2.5	220	0	-	8.5	-25	65	FKM	U133V7695	-	496565	0-20	Ex ia IIC T4 to T6	-	0.3	9.0/10.1	8166

Notes:

1. Valve delivered with an individual material traceability certificate (3.1 following EN10204)
2. Valve only compatible with hydraulic oil and air/neutral gases



For this page	Port size	Orifice (mm)	Qn (l/min)	MOPD (bar)	Fluid Temp (°C)	Amb Temp (°C)
From	1/4"	2	140	8.5	-25	-25
To	1/4"	2.5	220	12	80	50

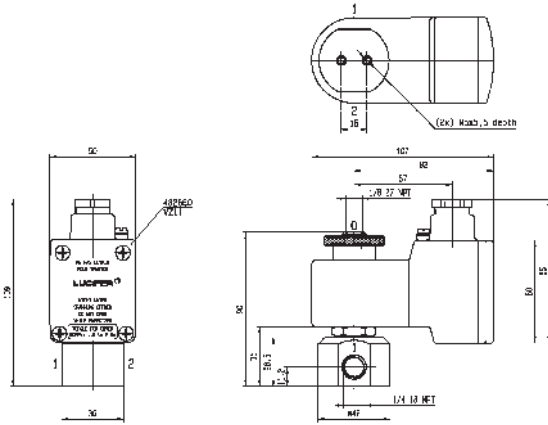

Drawing 6713

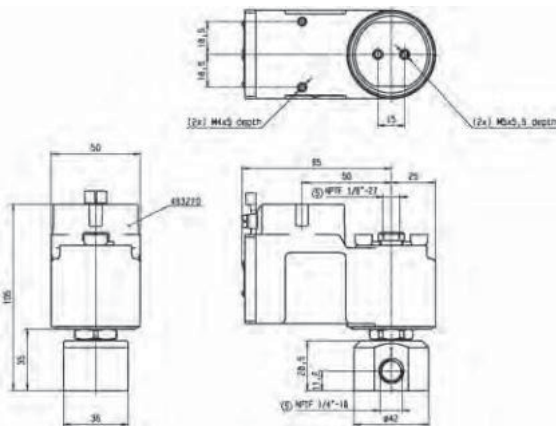

Drawing 6714

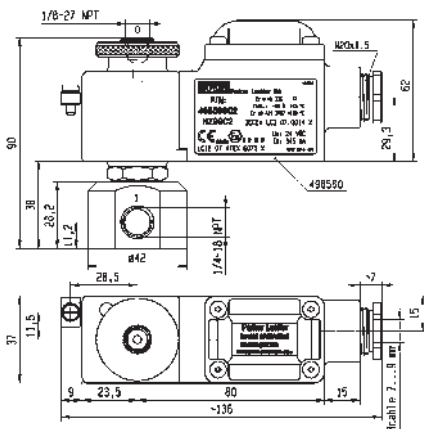

Drawing 8166

3/2

316L STAINLESS STEEL 3 & 5 WAY VALVES FOR ACTUATOR CONTROL (PIPE MOUNTING AND NAMUR) DIRECT OPERATED

316L STAINLESS ST. PIPE MOUNTING

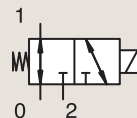

UNIVERSAL

Port size	Orifice Ø 1 mm	Flow factor Qn l/min	Operating Pressure Differential		Fluid Temp.		Seat Seal	Parker LUCIFER® Valves			ATEX Zone	Protection Mode	Power		Coil Group	Dwg. No.	
			Min	Max (MOPD)	Min	Max		Valve Ref.	Housing Ref.	Coil Ref.			AC W	DC W			
1/4" NPTF	6	680	0	10	10	-25	65	NBR	U133X5152 ₁₃	-	492310	1-21	Ex eb mb IIC T3 to T6	6	6	10.1/10.2	7770
	6	680	0	10	10	-25	65	NBR	U133X5152 ₁₃	-	496700	1-21	Ex db mb IIC T4 to T6	6	6	10.1/10.2	7770
	6	680	0	-	10	-25	65	NBR	U133X5156 ₂₃	-	492965.01	0-20	Ex ia IIC T6	-	0.3 to 3	9.0/10.1/10.2	7770
	6	680	0	10	10	-25	65	NBR	U133X5156 ₂₃	-	496700	1-21	Ex db mb IIC T4 to T6	6	6	9.0/10.1/10.2	7770
	6	680	0	10	10	-25	75	NBR	U133X51561D ₂₃	-	483270.02	1-21	Ex d IIC T4 to T6	8	8	11.0	7011
	6	680	0	10	10	-25	65	NBR	U133X5192 ₁₂	-	492310	1-21	Ex eb mb IIC T3 to T6	6	6	10.1	6904
	6	680	0	10	10	-25	65	NBR	U133X5192 ₁₂	-	496700	1-21	Ex db mb IIC T4 to T6	6	6	10.1	6904
	6	680	0	-	10	-25	65	NBR	U133X5196 ₂	-	492210	1-21	Ex eb mb IIC T5/T6	-	1.8	9.0/10.1/10.2	6904
	6	680	0	-	10	-25	65	NBR	U133X5196 ₂	-	492965.01	0-20	Ex ia IIC T6	-	0.3 to 3	9.0/10.1/10.2	6904
	6	680	0	10	10	-25	65	NBR	U133X5196 ₂	-	496700	1-21	Ex db mb IIC T4 to T6	6	6	9.0/10.1/10.2	6904

Notes:

1. DC voltage only (or coil with rectifier). Minimum drop off voltage is 15% of nominal voltage (former DIN 19251)
2. Valve delivered with an individual material traceability certificate (3.1 following EN10204)
3. With manual override

3 & 5 WAY PNEUMATIC DISTRIBUTORS



For this page	Port size	Orifice (mm)	Qn (l/min)	MOPD (bar)	Fluid Temp (°C)	Amb Temp (°C)
From	1/4"	6	680	10	-25	-25
To	1/4"	6	680	10	75	65

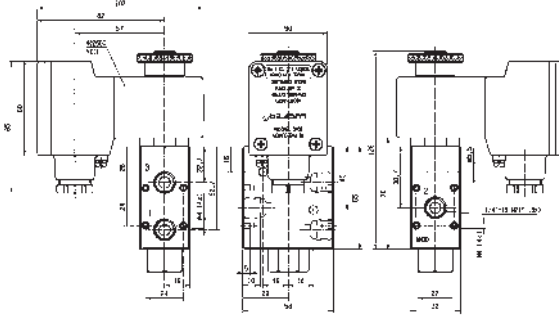

Drawing 7770

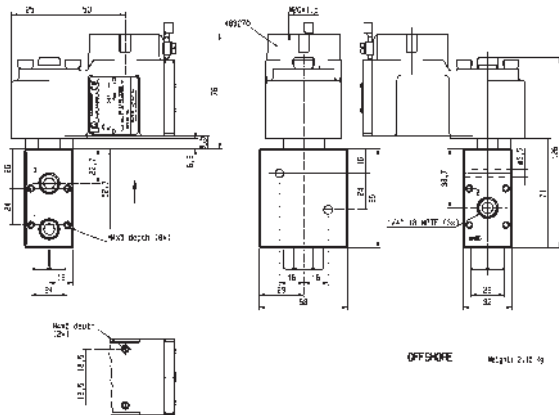

Drawing 7011

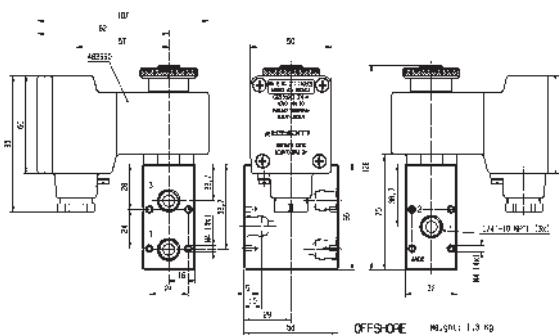

Drawing 6904

3/2

316L STAINLESS STEEL 3 & 5 WAY VALVES FOR ACTUATOR CONTROL (PIPE MOUNTING AND NAMUR) DIRECT OPERATED

316L STAINLESS ST.
PIPE MOUNTING

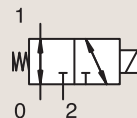

UNIVERSAL

Port size	Orifice Ø 1	Flow factor Qn l/min	Operating Pressure Differential			Fluid Temp.		Seat Seal	Parker LUCIFER® Valves			ATEX Zone	Protection Mode	Power		Coil Group	Dwg. No.
			Min	Max (MOPD)	DC	Min	Max		Valve Ref.	Housing Ref.	Coil Ref.			AC W	DC W		
1/4" NPTF	6	680	0	10	10	-25	65	NBR	U133X51961D ₁	-	483270.02	1-21	Ex db IIC T4 to T6	8	8	11.0	7038
	6	680	0	10	10	-25	65	NBR	U133X7156 ₂	-	496700	1-21	Ex db mb IIC T4 to T6	6	6	9.0/10.1/10.2	8168
	6	680	0	-	10	-25	65	NBR	U133X7196	-	492210	1-21	Ex eb mb IIC T5/T6	-	1.8	9.0/10.1/10.2	8169
	6	680	0	-	10	-25	65	NBR	U133X7196	-	492965.01	0-20	Ex ia IIC T6	-	0.3 to 3	9.0/10.1/10.2	8169
	6	680	0	10	10	-25	65	NBR	U133X7196	-	496700	1-21	Ex db mb IIC T4 to T6	6	6	9.0/10.1/10.2	8169

Notes:

1. Valve delivered with an individual material traceability certificate (3.1 following EN10204)
2. With manual override



For this page	Port size	Orifice (mm)	Qn (l/min)	MOPD (bar)	Fluid Temp (°C)	Amb Temp (°C)
From	1/4"	6	680	10	-25	-25
To	1/4"	6	680	10	65	65

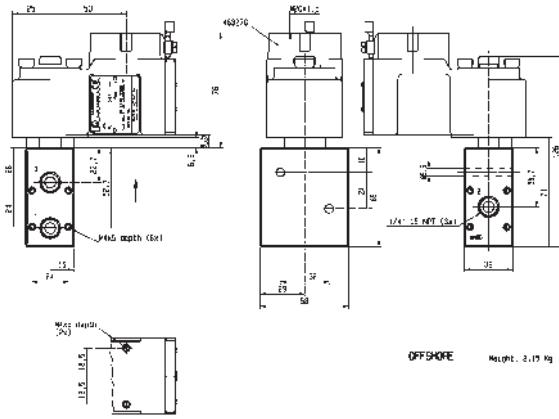

OFFSHORE Weight: 2.15 kg



Drawing 7038

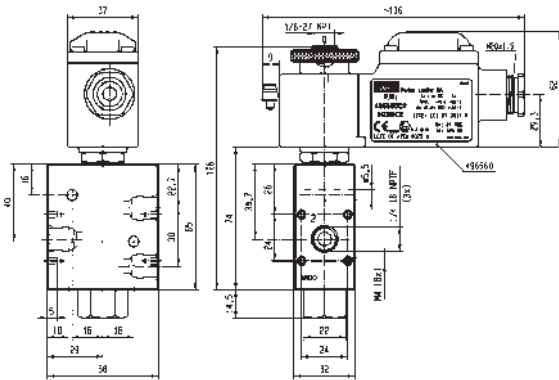

Drawing 8168

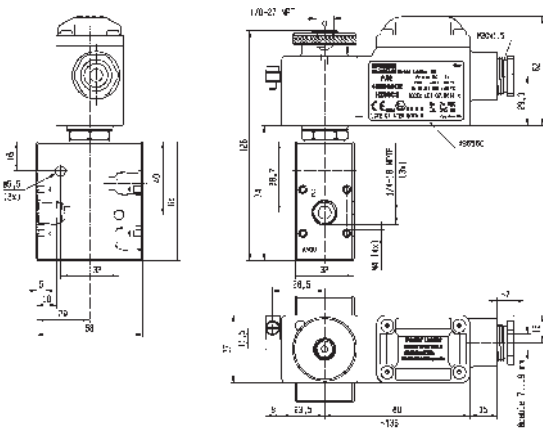

Drawing 8169



3/2

316L STAINLESS STEEL 3 & 5 WAY VALVES FOR ACTUATOR CONTROL (PIPE MOUNTING AND NAMUR) DIRECT OPERATED

316L STAINLESS ST.
PIPE MOUNTING

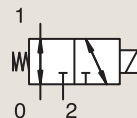

UNIVERSAL

Port size	Orifice Ø 1 mm	Flow factor Qn l/min	Operating Pressure Differential			Fluid Temp.		Seat Seal	Parker LUCIFER® Valves			ATEX Zone	Protection Mode	Power		Coil Group	Dwg. No.
			Min	Max (MOPD)	Max	Min	Max		Valve Ref.	Housing Ref.	Coil Ref.			AC W	DC W		
3/8" NPTF	6	680	0	10	10	-25	65	NBR	U133X5296 ₁	-	492310	1-21	Ex eb mb II T3 to T6	6	6	9.0/10.1/10.2	7669
	6	680	0	-	10	-25	65	NBR	U133X5296 ₁	-	492965.01	0-20	Ex ia IIC T6	-	0.3 to 3	9.0/10.1/10.2	7669
	6	680	0	10	10	-25	65	NBR	U133X5296 ₁	-	496700	1-21	Ex db mb IIC T4 to T6	6	6	9.0/10.1/10.2	7669
	6	680	0	10	10	-25	75	NBR	U133X52961D ₁	-	483270.02	1-21	Ex db IIC T4 to T6	8	8	11.0	7670

Notes:

1. Valve delivered with an individual material traceability certificate (3.1 following EN10204)



For this page	Port size	Orifice (mm)	Qn (l/min)	MOPD (bar)	Fluid Temp (°C)	Amb Temp (°C)
From	3/8"	6	680	10	-25	-25
To	3/8"	6	680	10	75	65

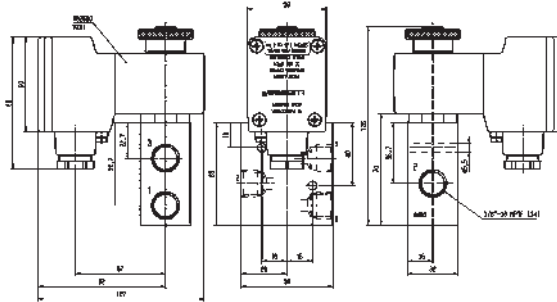

Drawing 7669

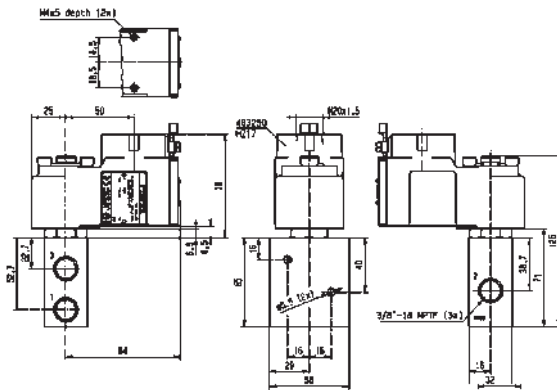

Drawing 7670

3/2

316L STAINLESS STEEL 3 & 5 WAY VALVES FOR ACTUATOR CONTROL (PIPE MOUNTING AND NAMUR) DIRECT OPERATED

316L STAINLESS ST. SUB-BASE MOUNTING

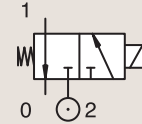

NORMALLY CLOSED

Port size	Orifice Ø 1 mm	Flow factor Qn l/min	Operating Pressure Differential		Fluid Temp.		Seat Seal	Parker LUCIFER® Valves			ATEX Zone	Protection Mode	Power		Coil Group	Dwg. No.
			Min AC bar	Max (MOPD) DC bar	Min °C	Max °C		Valve Ref.	Housing Ref.	Coil Ref.			AC W	DC W		
SB	2.5	220	0	- 12	-25 65	FKM	U131F5695 ₁	-	492210	1-21	Ex eb mb IIC T5/T6	-	1.8	9.0/10.1	3782	
	2.5	220	0	- 12	-25 65	FKM	U131F5695 ₁	-	492965.01	0-20	Ex ia IIC T6	-	0.3 to 3	9.0/10.1	3782	
	2.5	220	0	12 12	-25 75	FKM	U131F5695 ₁	-	496800	1-21	Ex db mb IIC T4	8	8	9.0/10.1	3782	
	2.5	220	0	14 14	-10 80	FKM	U131F56951D ₁₂	-	483270.02	1-21	Ex db IIC T4 to T6	8	8	11.0	3783	
SB	2.5	220	0	10 10	-25 75	FKM	U131F5295	-	496560	1-21	Ex db mb IIC T4	8	8	9.0/10.1	8174	

Notes:

1. Valve delivered with an individual material traceability certificate (3.1 following EN10204)
2. Valve only compatible with hydraulic oil and air/neutral gases

316L STAINLESS ST. SUB-BASE MOUNTING

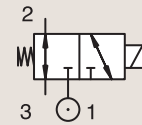

UNIVERSAL

Port size	Orifice Ø 1 mm	Flow factor Qn l/min	Operating Pressure Differential		Fluid Temp.		Seat Seal	Parker LUCIFER® Valves			ATEX Zone	Protection Mode	Power		Coil Group	Dwg. No.
			Min AC bar	Max (MOPD) DC bar	Min °C	Max °C		Valve Ref.	Housing Ref.	Coil Ref.			AC W	DC W		
1/4" NPTF	6	680	0	10 10	-25 65	FKM	U133X5195 ₁	-	492310	1-21	Ex eb mb II T3 to T6	6	6	9.0/10.1/10.2	3572	
	6	680	0	10 10	-25 65	FKM	U133X5195 ₁	-	496700	1-21	Ex db mb IIC T4 to T6	6	6	9.0/10.1/10.2	3572	

Notes:

1. Valve delivered with an individual material traceability certificate (3.1 following EN10204)

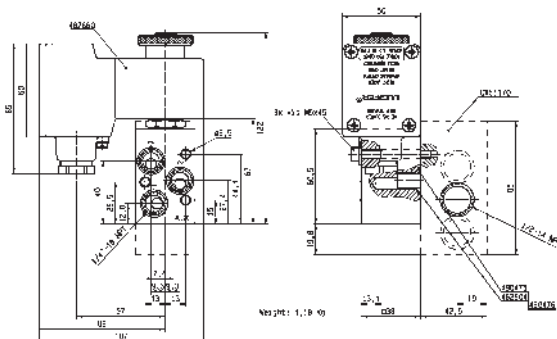

Drawing 3572



For this page	Port size	Orifice (mm)	Qn (l/min)	MOPD (bar)	Fluid Temp (°C)	Amb Temp (°C)
From	SB	2.5	220	10	-25	-25
To	SB	6	680	14	80	50

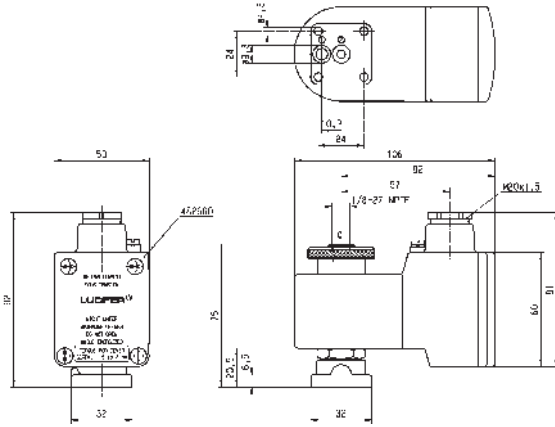

Drawing 3782

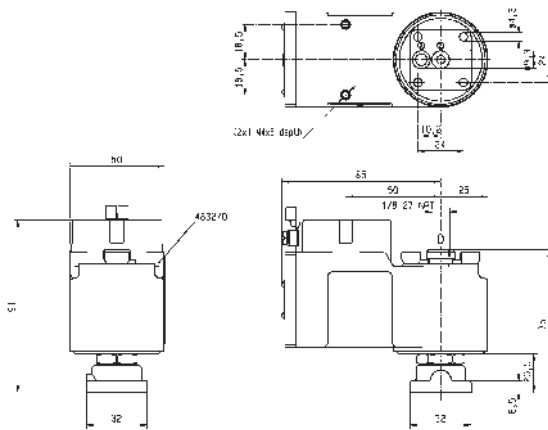

Drawing 3783

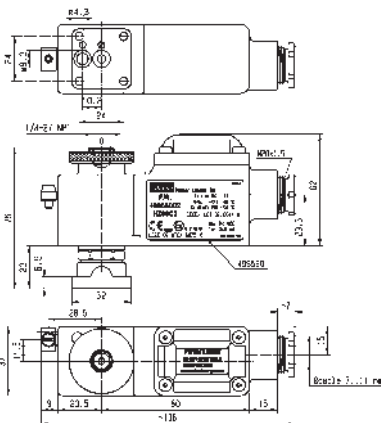

Drawing 8174

3/2

316L STAINLESS STEEL 3 & 5 WAY VALVES FOR ACTUATOR CONTROL (PIPE MOUNTING AND NAMUR) DIRECT OPERATED

316L STAINLESS ST. SUB-BASE MOUNTING

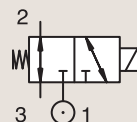

UNIVERSAL

Port size	Orifice Ø 1	Flow factor Qn l/min	Operating Pressure Differential			Fluid Temp.		Seat Seal	Parker LUCIFER® Valves			ATEX Zone	Protection Mode	Power		Coil Group	Dwg. No.
			Min	Max (MOPD)	DC bar	Min	Max		Valve Ref.	Housing Ref.	Coil Ref.			AC W	DC W		
			bar	AC bar		°C	°C										
1/4" NPTF	6	680	0	10	10	-25	65	FKM	U133X51951D ₁	-	483270	1-21	Ex db IIC T4 to T6	8	8	11.0	3688
	6	680	0	10	10	-25	65	FKM	U133X51951D ₁	-	483270.02	1-21	Ex db IIC T4 to T6	8	8	11.0	3688
	6	680	0	-	10	-25	65	FKM	U133X7195	-	492210	1-21	Ex eb mb IIC T5/T6	-	1.8	9.0/10.1/10.2	8172
	6	680	0	-	10	-25	65	FKM	U133X7195	-	492965.01	0-20	Ex ia IIC T6	-	0.3 to 3	9.0/10.1/10.2	8172
	6	680	0	10	10	-25	65	FKM	U133X7195	-	496700	1-21	Ex db mb IIC T4 to T6	6	6	9.0/10.1/10.2	8172

Notes:

1. Valve delivered with an individual material traceability certificate (3.1 following EN10204)

316L STAINLESS ST. NAMUR

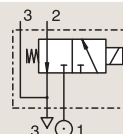

NORMALLY CLOSED

Port size	Orifice Ø 1	Flow factor Qn l/min	Operating Pressure Differential			Fluid Temp.		Seat Seal	Parker LUCIFER® Valves			ATEX Zone	Protection Mode	Power		Coil Group	Dwg. No.
			Min	Max (MOPD)	DC bar	Min	Max		Valve Ref.	Housing Ref.	Coil Ref.			AC W	DC W		
			bar	AC bar		°C	°C										
3/8" NPT	6	680	0	10	10	-25	65	NBR	U131X1201 ₁	-	492310	1-21	Ex eb mb II T3 to T6	6	6	9.0/10.1/10.2	7668
	6	680	0	-	10	-25	75	NBR	U131X1201 ₁	-	492965.01	0-20	Ex ia IIC T6	-	0.3 to 3	9.0/10.1/10.2	7668
	6	680	0	10	10	-25	65	NBR	U131X1201 ₁	-	496700	1-21	Ex db mb IIC T4 to T6	6	6	9.0/10.1/10.2	7668

Notes:

1. Valve delivered with an individual material traceability certificate (3.1 following EN10204)



For this page	Port size	Orifice (mm)	Qn (l/min)	MOPD (bar)	Fluid Temp (°C)	Amb Temp (°C)
From	1/4"	6	680	10	-25	-25
To	3/8"	6	680	10	75	65

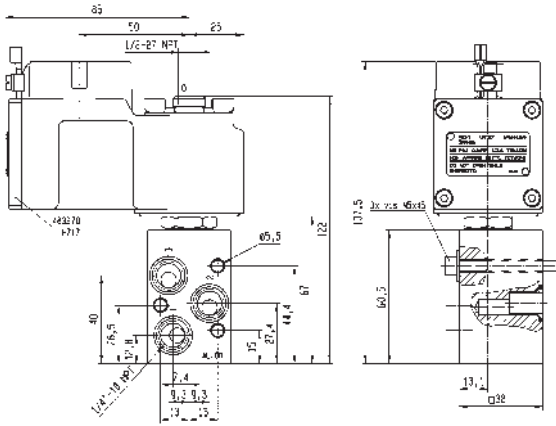

Drawing 3688

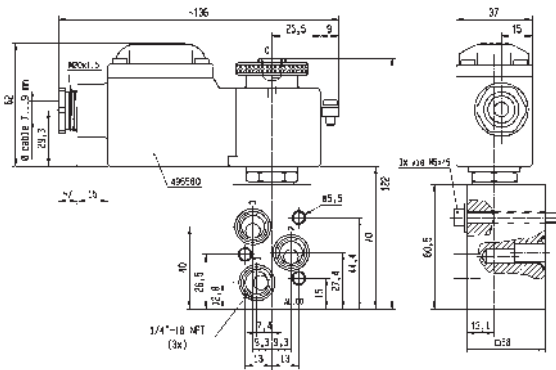

Drawing 8172

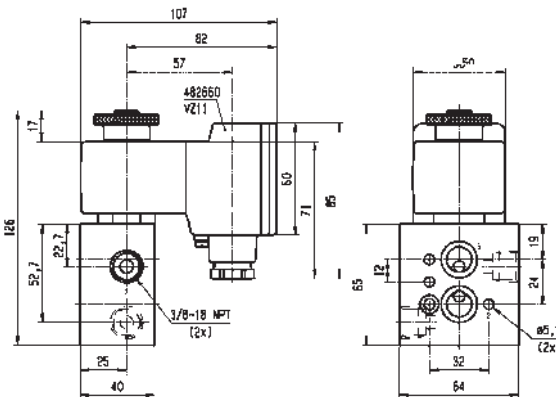

Drawing 7668

5/2

316L STAINLESS STEEL 3 & 5 WAY VALVES FOR ACTUATOR CONTROL (PIPE MOUNTING AND NAMUR) PILOT OPERATED



Process

316L STAINLESS ST. PIPE MOUNTING

NORMALLY CLOSED

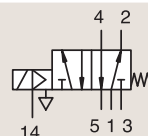

Port size	Orifice Ø 1 mm	Flow factor Qn l/min	Operating Pressure Differential			Fluid Temp.		Seat Seal	Parker LUCIFER® Valves			ATEX Zone	Protection Mode	Power		Coil Group	Dwg. No.
			Min	Max (MOPD)	DC bar	Min	Max		Valve Ref.	Housing Ref.	Coil Ref.			AC W	DC W		
			bar	AC bar	DC bar	°C	°C										
3/8" NPT	8	1400	2	10	10	-25	80	NBR	U441P3250 ₁₂	4270	481000	-	-	8	8	2.1	7565
	8	1400	2	10	10	-25	80	NBR	U441P3250 ₁₂	2995	481865	-	-	8	9	2.1	7565

Notes:

1. Pilot seat in FKM
2. Valve with external pilot pressure minimum 4 bar

316L STAINLESS ST. PIPE MOUNTING

NORMALLY CLOSED

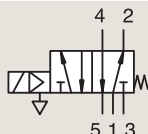

Port size	Orifice Ø 1 mm	Flow factor Qn l/min	Operating Pressure Differential			Fluid Temp.		Seat Seal	Parker LUCIFER® Valves			ATEX Zone	Protection Mode	Power		Coil Group	Dwg. No.
			Min	Max (MOPD)	DC bar	Min	Max		Valve Ref.	Housing Ref.	Coil Ref.			AC W	DC W		
			bar	AC bar	DC bar	°C	°C										
1/4" 1/8" NPT	8	1400	2	10	10	-25	80	NBR	U341P0250 ₁₂₃	8993	481045	-	-	2	2.5	1.1	7578
	8	1400	2	10	10	-25	80	NBR	U341P0250 ₁₂₃	-	482606	1-21	Ex mb IIC T4/T5	2	2.5	1.1	7578
1/4" 3/8" NPT	8	1400	2	10	10	-25	80	NBR	U341P3250 ₁	4270	481000	-	-	8	8	2.1	7558
	8	1400	2	10	10	-25	80	NBR	U341P3250 ₁	2995	481865	-	-	8	9	2.1	7558
	8	1400	2	10	10	-25	80	NBR	U341P3250 ₁	2995	492453	-	-	8	9	2.1	7558

Notes:

1. Pilot seat in FKM
2. With captured exhaust
3. With manual override



For this page	Port size	Orifice (mm)	Qn (l/min)	MOPD (bar)	Fluid Temp (°C)	Amb Temp (°C)
From	3/8"	8	1400	10	-25	-25
To	3/8"	8	1400	10	80	50

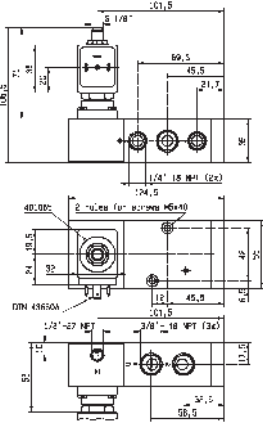

Drawing 7566

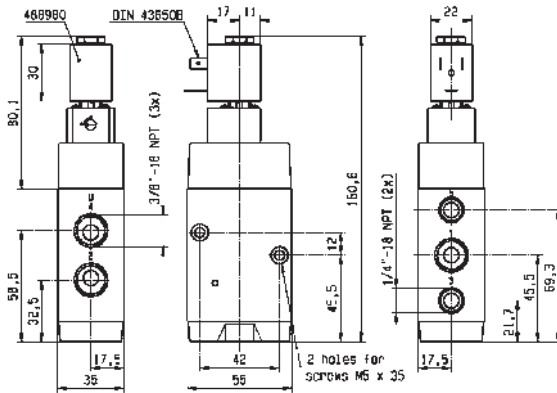

Drawing 7578

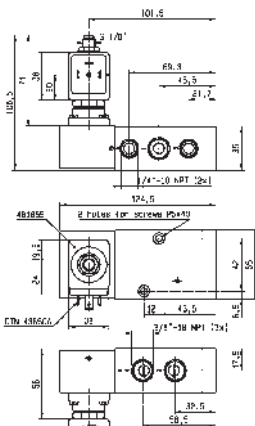

Drawing 7558

5/2

316L STAINLESS STEEL 3 & 5 WAY VALVES FOR ACTUATOR CONTROL (PIPE MOUNTING AND NAMUR) PILOT OPERATED

316L STAINLESS ST.
PIPE MOUNTING

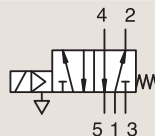

NORMALLY CLOSED

Port size	Orifice Ø 1 mm	Flow factor Qn l/min	Operating Pressure Differential		Fluid Temp.		Seat Seal	Parker LUCIFER® Valves			ATEX Zone	Protection Mode	Power		Coil Group	Dwg. No.
			Min	Max (MOPD) AC bar DC bar	Min	Max		Valve Ref.	Housing Ref.	Coil Ref.			AC W	DC W		
3/8" NPT	8	1400	2	- 10	-25	55	NBR	U341P3292 ₁	2995	483580.01	0-20	Ex ia IIC T6	-	0.5 to 3	7.0	7560
	8	1400	2	10 10	-25	75	NBR	U341P3295 ₁	-	492310	1-21	Ex eb mb II T3 to T6	6	6	9.0/10.1	7561
	8	1400	2	- 10	-25	75	NBR	U341P3295 ₁	-	492965.01	0-20	Ex ia IIC T6	-	0.3 to 3	9.0/10.1	7561

Notes:

1. Pilot seat in FKM



For this page	Port size	Orifice (mm)	Qn (l/min)	MOPD (bar)	Fluid Temp (°C)	Amb Temp (°C)
From	3/8"	8	1400	10	-25	-25
To	3/8"	8	1400	10	75	50

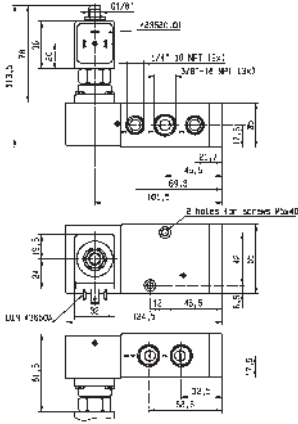

Drawing 7560

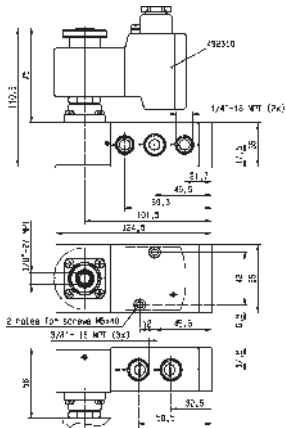

Drawing 7561

5/2

316L STAINLESS STEEL 3 & 5 WAY VALVES FOR ACTUATOR CONTROL (PIPE MOUNTING AND NAMUR) PILOT OPERATED

316L STAINLESS ST.
PIPE MOUNTING

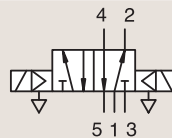

DUAL SOLENOIDS

Port size	Orifice Ø 1 mm	Flow factor Qn l/min	Operating Pressure Differential			Fluid Temp.		Seat Seal	Parker LUCIFER® Valves			ATEX Zone	Protection Mode	Power		Coil Group	Dwg. No.
			Min	Max (MOPD)	DC bar	Min	Max		Valve Ref.	Housing Ref.	Coil Ref.			AC W	DC W		
3/8" NPT	8	1400	2	10	10	-25	80	NBR	U347P3250	4270	481000	-	-	8	8	2.1	7563
	8	1400	2	10	10	-25	80	NBR	U347P3250	-	483371	1-21	Ex eb IIC T4	8	8	2.1	7563
	8	1400	2	10	10	-25	75	NBR	U347P3295	-	492310	1-21	Ex eb mb II T3 to T6	6	6	9.0/10.1	7564
	8	1400	2	10	10	-25	75	NBR	U347P3295	-	496800	1-21	Ex db mb IIC T4	8	8	9.0/10.1	7564

Notes:

1. Pilot seat in FKM



For this page	Port size	Orifice (mm)	Qn (l/min)	MOPD (bar)	Fluid Temp (°C)	Amb Temp (°C)
From	3/8"	8	1400	10	-25	-25
To	3/8"	8	1400	10	80	50

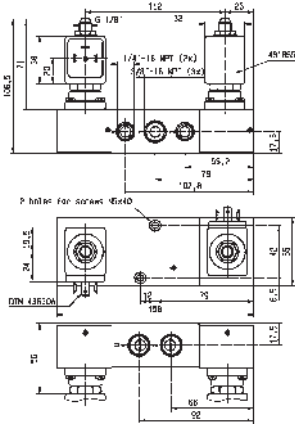

Drawing 7563

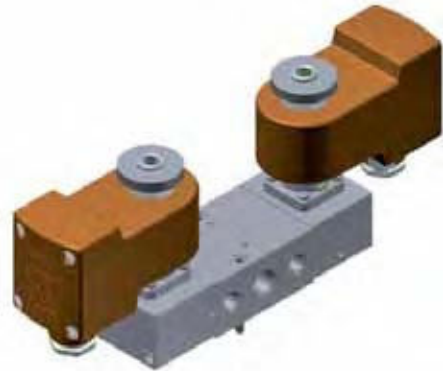
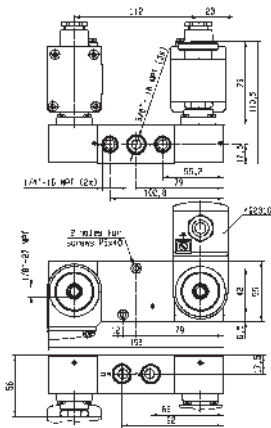

Drawing 7564

3/2-5/2

316L STAINLESS STEEL 3 & 5 WAY VALVES FOR ACTUATOR CONTROL (PIPE MOUNTING AND NAMUR) PILOT OPERATED

316L STAINLESS ST.
NAMUR

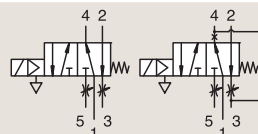

NORMALLY CLOSED

Port size	Orifice Ø 1	Flow factor Qn l/min	Operating Pressure Differential			Fluid Temp.		Seat Seal	Parker LUCIFER® Valves			ATEX Zone	Protection Mode	Power		Coil Group	Dwg. No.
			Min	Max (MOPD)	DC	Min	Max		Valve Ref.	Housing Ref.	Coil Ref.			AC W	DC W		
3/8"- 1/4" NPT	8	1400	2	10	10	-25	80	NBR	U341N3250	2995	481865	-	-	8	9	2.1	7554
	8	1400	2	10	10	-25	80	NBR	U341N3250	-	492190	1-21	Ex eb mb IIC T3/T4	11	9	2.1	7554
	8	1400	2	-	10	-25	55	NBR	U341N3292	2995	483580.01	0-20	Ex ia IIC T6	-	0.5 to 3	7.0	7556
	8	1400	2	10	10	-25	75	NBR	U341N3295	-	492310	1-21	Ex eb mb II T3 to T6	6	6	9.0/10.1	7696
	8	1400	2	10	10	-25	75	NBR	U341N3295	-	496800	1-21	Ex db mb IIC T4	8	8	9.0/10.1	7696

Notes:

1. Pilot seat in FKM



For this page	Port size	Orifice (mm)	Qn (l/min)	MOPD (bar)	Fluid Temp (°C)	Amb Temp (°C)
From	3/8"-1/4"	8	1400	10	-25	-25
To	3/8"-1/4"	8	1400	10	80	50

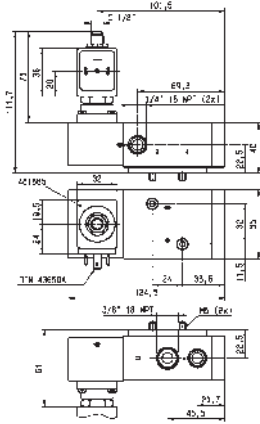

Drawing 7554

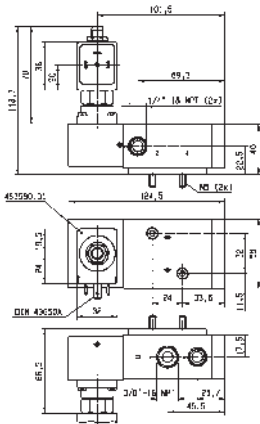

Drawing 7556

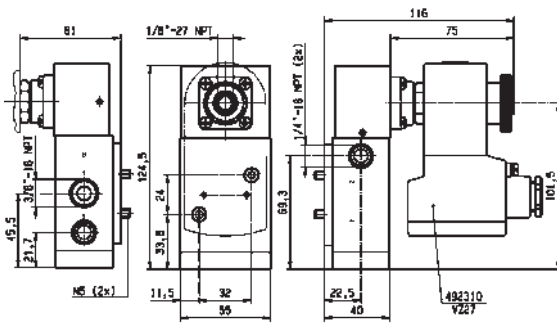

Drawing 7696

3/2-5/2

**316L STAINLESS STEEL 3 & 5 WAY VALVES
FOR ACTUATOR CONTROL (PIPE MOUNTING AND NAMUR)
PILOT OPERATED**

**316L STAINLESS ST.
NAMUR**

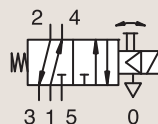

SOLENOID OPERATED - SPRING RETURN

Port size	Orifice Ø 1 mm	Flow factor Qn l/min	Operating Pressure Differential			Fluid Temp.		Seat Seal	Parker LUCIFER® Valves			ATEX Zone	Protection Mode	Power		Coil Group	Dwg. No.
			Min	Max (MOPD)	DC	Min	Max		Valve Ref.	Housing Ref.	Coil Ref.			AC W	DC W		
3/8"- 1/4"NPT	8	1400	2	10	10	-25	80	NBR	U341N0250 ₁₂₃	-	482606	1-21	Ex mb IIC T4/T5	2	2.5	1.1	7577
	8	1400	2	10	10	-25	80	NBR	U341N0250 ₁₂₃	8993	488980	-	-	2	2.5	1.1	7577

Notes:

1. Pilot seat in FKM
2. With captured exhaust
3. With manual override



For this page	Port size	Orifice (mm)	Qn (l/min)	MOPD (bar)	Fluid Temp (°C)	Amb Temp (°C)
From	3/8"-1/4"	8	1400	10	-25	-25
To	3/8"-1/4"	8	1400	10	80	50

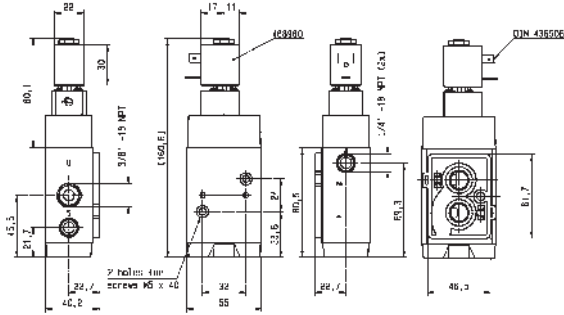

Drawing 7577

5/2

316L STAINLESS STEEL 3 & 5 WAY VALVES FOR ACTUATOR CONTROL (PIPE MOUNTING AND NAMUR) PILOT OPERATED

316L STAINLESS ST.
NAMUR

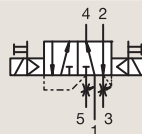

DUAL SOLENOIDS

Port size	Orifice Ø 1 mm	Flow factor Qn l/min	Operating Pressure Differential			Fluid Temp.		Seat Seal	Parker LUCIFER® Valves			ATEX Zone	Protection Mode	Power		Coil Group	Dwg. No.
			Min bar	Max (MOPD)		Min °C	Max °C		Valve Ref.	Housing Ref.	Coil Ref.			AC W	DC W		
				AC bar	DC bar												
3/8"- 1/4"NPT	8	1400	2	10	10	-25	80	NBR	U347N3250	4270	481000	-	-	8	8	2.1	7557
	8	1400	2	10	10	-25	80	NBR	U347N3250	2995	481865	-	-	8	9	2.1	7557

Notes:

1. Pilot seat in FKM



For this page	Port size	Orifice (mm)	Qn (l/min)	MOPD (bar)	Fluid Temp (°C)	Amb Temp (°C)
From	3/8"-1/4"	8	1400	10	-25	-25
To	3/8"-1/4"	8	1400	10	80	50

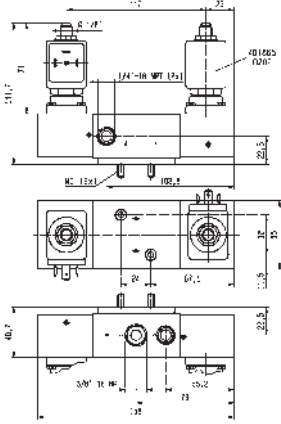

Drawing 7557

3/2

316L STAINLESS STEEL 3 & 5 WAY VALVES FOR ACTUATOR CONTROL (PIPE MOUNTING AND NAMUR) MANUAL RESET



Process

316L STAINLESS ST. PIPE MOUNTING

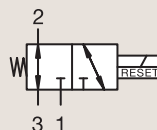

UNIVERSAL

Port size	Orifice Ø 1 mm	Flow factor Qn l/min	Operating Pressure Differential			Fluid Temp.		Seat Seal	Parker LUCIFER® Valves			ATEX Zone	Protection Mode	Power		Coil Group	Dwg. No.
			Min	Max (MOPD)	Max	Min	Max		Valve Ref.	Housing Ref.	Coil Ref.			AC W	DC W		
1/4" NPTF	6	680	0	10	10	-25	65	NBR	U033X5152 ₁₂	-	492310	1-21	Ex eb mb II T3 to T6	6	6	10.1/10.2	7029
	6	680	0	-	10	-25	65	NBR	U033X5156 ₂	-	482870.01	0-20	Ex ia IIC T6	-	0.3 to 3	10.1/10.2/12.0	7771
	6	680	0	10	10	-25	65	NBR	U033X5156 ₂	-	492310	1-21	Ex eb mb II T3 to T6	6	6	10.1/10.2/12.0	7771
	6	680	0	-	10	-25	65	NBR	U033X5156 ₂	-	492335	0-20	NEMA 4-4X	-	0.3 to 3	10.1/10.2/12.0	7771
	6	680	0	10	10	-25	65	NBR	U033X5156 ₂	-	496700	1-21	Ex db mb IIC T4 to T6	6	6	10.1/10.2/12.0	7771
	6	680	0	10	10	-25	75	NBR	U033X51561D ₂	-	483270.02	1-21	Ex db IIC T4 to T6	8	8	11.0	7030

Notes:

1. DC voltage only (or coil with rectifier). Minimum drop off voltage is 15% of nominal voltage (former DIN 19251)
2. Valve delivered with an individual material traceability certificate (3.1 following EN10204)

3 & 5 WAY PNEUMATIC DISTRIBUTORS



For this page	Port size	Orifice (mm)	Qn (l/min)	MOPD (bar)	Fluid Temp (°C)	Amb Temp (°C)
From	1/4"	6	680	10	-25	-25
To	1/4"	6	680	10	75	65

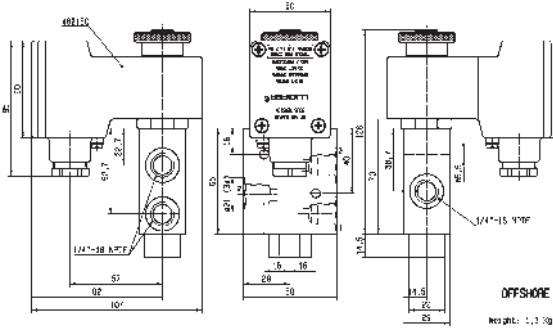

Drawing 7029

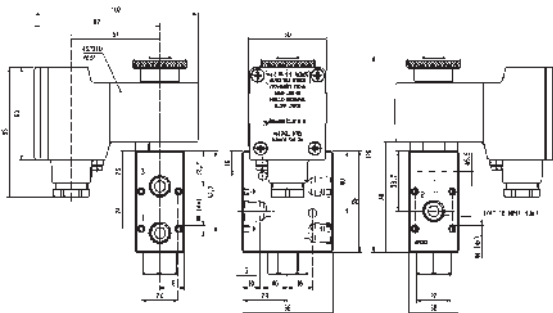

Drawing 7771

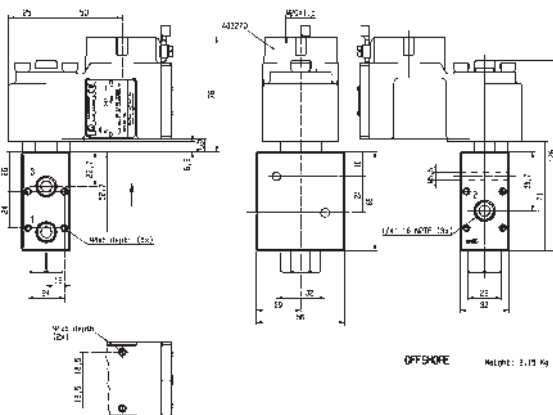

Drawing 7030

3/2

316L STAINLESS STEEL 3 & 5 WAY VALVES FOR ACTUATOR CONTROL (PIPE MOUNTING AND NAMUR) MANUAL RESET

316L STAINLESS ST. PIPE MOUNTING

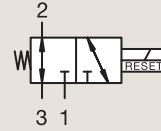

UNIVERSAL

Port size	Orifice Ø 1	Flow factor Qn l/min	Operating Pressure Differential			Fluid Temp.		Seat Seal	Parker LUCIFER® Valves			ATEX Zone	Protection Mode	Power		Coil Group	Dwg. No.
			Min	Max (MOPD)	Max	Min	Max		Valve Ref.	Housing Ref.	Coil Ref.			AC W	DC W		
1/4" NPTF	6	560	0	10	10	-25	65	NBR	U033X5195 ₂	-	492310	1-21	Ex eb mb II T3 to T6	6	6	10.1/10.2/12.0	3594
	6	560	0	10	10	-25	65	NBR	U033X5195 ₂	-	496700	1-21	Ex db mb IIC T4 to T6	6	6	10.1/10.2/12.0	3594
	6	680	0	10	10	-25	65	NBR	U033X7156 ₁	-	492310	1-21	Ex eb mb II T3 to T6	6	6	10.1/10.2	8168
	6	680	0	10	10	-25	65	NBR	U033X7156	-	496560	1-21	Ex db mb IIC T4	8	8	10.1/10.2	8168
	6	680	0	10	10	-25	65	NBR	U033X7156	-	496700	1-21	Ex db mb IIC T4 to T6	6	6	10.1/10.2	8168
	6	680	0	10	10	-25	65	NBR	U033X7156	-	496895	-	-	8	8	10.1/10.2	8168

Notes:

1. DC voltage only (or coil with rectifier). Minimum drop off voltage is 15% of nominal voltage (former DIN 19251)
2. Valve delivered with an individual material traceability certificate (3.1 following EN10204)



For this page	Port size	Orifice (mm)	Qn (l/min)	MOPD (bar)	Fluid Temp (°C)	Amb Temp (°C)
From	1/4"	6	560	10	-25	-25
To	1/4"	6	680	10	65	65

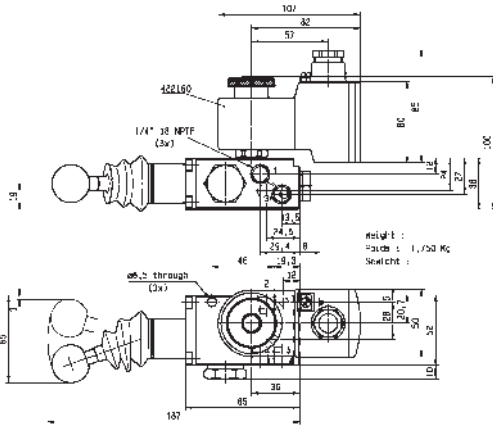

Drawing 3594

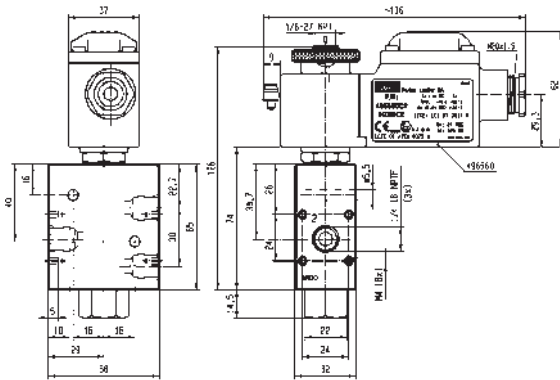

Drawing 8168

3/2

316L STAINLESS STEEL 3 & 5 WAY VALVES FOR ACTUATOR CONTROL (PIPE MOUNTING AND NAMUR) MANUAL RESET

316L STAINLESS ST.
PIPE MOUNTING

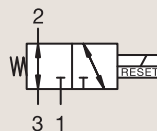

UNIVERSAL

Port size	Orifice Ø 1 mm	Flow factor Qn l/min	Operating Pressure Differential			Fluid Temp.		Seat Seal	Parker LUCIFER® Valves			ATEX Zone	Protection Mode	Power		Coil Group	Dwg. No.
			Min	Max (MOPD)	AC	DC	Min		Max	Valve Ref.	Housing Ref.			Coil Ref.	AC W		
3/8" NPTF	6	680	0	-	10	-25	65	NBR	U033X5256 ₁	-	482870.01	0-20	Ex ia IIC T6	-	0.3 to 3	10.1/10.2/12.0	7671
	6	680	0	10	10	-25	65	NBR	U033X5256 ₁	-	492310	1-21	Ex eb mb II T3 to T6	6	6	10.1/10.2/12.0	7671
	6	680	0	10	10	-25	65	NBR	U033X5256 ₁	-	496700	1-21	Ex db mb IIC T4 to T6	6	6	10.1/10.2/12.0	7671
	6	680	0	10	10	-25	65	NBR	U033X52561D ₁	-	483270	1-21	Ex db IIC T4 to T6	8	8	11.0	7672
	6	680	0	10	10	-25	65	NBR	U033X52561D ₁	-	483270.02	1-21	Ex db IIC T4 to T6	8	8	11.0	7672

Notes:

1. Valve delivered with an individual material traceability certificate (3.1 following EN10204)



For this page	Port size	Orifice (mm)	Qn (l/min)	MOPD (bar)	Fluid Temp (°C)	Amb Temp (°C)
From	3/8"	6	680	10	-25	-25
To	3/8"	6	680	10	65	65

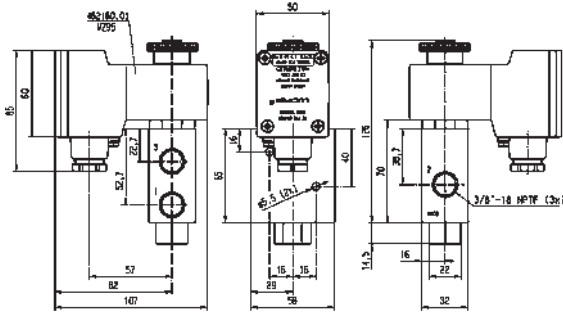

Drawing 7671

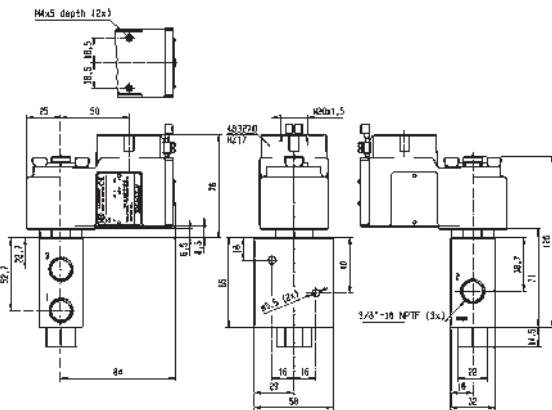

Drawing 7672

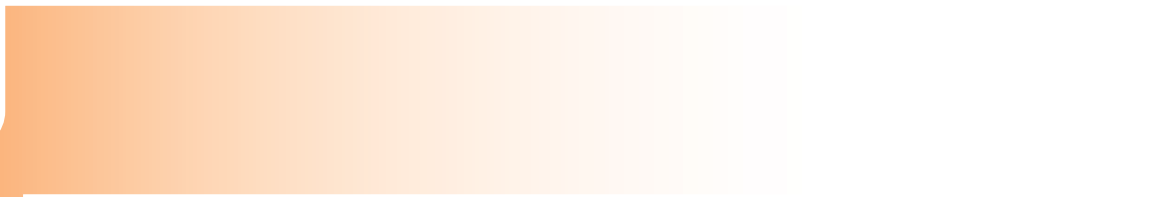

ELECTROPNEUMATIC PRESSURE REGULATORS



aerospace
 climate control
 electromechanical
 filtration
 fluid & gas handling
 hydraulics
 pneumatics
 process control
 sealing & shielding

Basic	1/4" 1/2"
Comfort	1/4" 1/2"
Comfort	1/2" HP 1" 2"
Comfort ATEX	1/2" 1" 2"



ELECTROPNEUMATIC PRESSURE REGULATORS

Lucifer® EPP4 Programmable Pressure Regulator

EPP4 is an electro pneumatic pressure regulator with integrated electronic system.

A pulsed width modulated solenoid valve controls the output pressure proportionally to an analog input signal.

Very high accuracy is guaranteed thanks to a high precision closed loop signal provided by a built in pressure sensor.



Market

Robotics
Paper industry
Machine tools
Mobile
Buildings
Textile
Instrumentation
Semi conductor



Description of Applications

Welding
Speed and brake control
Sanding
Cutting
Humidification
Tension regulation
Painting
Presses
Polishing
Adaptative suspension control



Value Propositions for the Lucifer® EPP4 Range of Proportional Pressure Regulators

- All parameters fully adjustable through the PC software Calys
- Easy to use software
- Long life expectancy
- Compact and light
- Limited inventory
- Low power
- Flexible remote display positioning
- Proven expertise of Parker, a pioneer in pressure regulation technology



calys Software for EPP Comfort

Calys is a unique software in house developed to configurate all the parameters of the EPP4 Comfort range.

Calys is an option of the EPP4. To use CALYS, you need to order cable reference 496449 wich permits the communication between the EPP4 and a PC.

Calys offers many capabilities:

- It enables distributors to reduce inventory by keeping a generic EPP4 in stock and adjust it to the needs of each customer application. They can switch for example from 0-10 V to 4-20 mA, or from 0-7 bar pressure range to 0-5 bar.
- Engineers designing a pneumatic system are able to monitor precisely all the important values (electrical or pneumatical) directly on their laptop.
- After sales technicians are able to receive via email all the parameters measured by the EPP4 installed on a machine wherever its location allowing remote ma intenance operation.
- PID regulation parameters can be adjusted with Calys to match required regulator response (like slow or reactive).



To download free Calys software click on www.parker.com/FCDE/Support

ELECTROPNEUMATIC PRESSURE REGULATORS



TABLE OF CONTENT

Introduction EPPpage 412

EPP4 Basic Rangepage 414

EPP4 Comfort Rangepage 418

EPP4 Comfort HP Rangepage 422

EPP4 Comfort Range ATEXpage 428

Accessoriespage 434



INTRODUCTION

Description Operation

The EPP4 Series is a family of electrically remote-controlled pneumatic pressure regulators with closed loop integrated electronic control.

It allows regulating the outlet pressure proportionally to an electrical control signal.

The EPP4 regulator comprises a traditional servo-operated pneumatic pressure regulator, where the pilot chamber is fed by one or the other of two pulse width modulated 2-way solenoid valves.

The pressure sensor measures the outlet pressure of the regulator and provides a feedback signal to the controller.

Any difference between the control signal and the feedback signal is converted to a digital signal to energise the coil of one or the other 2-way valves to correct the position of the regulator.

The control signal can be a voltage (0-10 V) or a current (4-20 mA). The inlet of the "Filling Valve" is connected directly to the main inlet P of the

regulator; when energised this valve will fill the servo-chamber for increasing the pressure at the outlet A of the regulator.

When the other "exhaust valve" is energised (reduction of pressure at the outlet A of the regulator), the pressure of the servo-chamber will be exhausted through a discharge orifice located between the cover and the body and directly fed to the atmosphere without silencer.

The exhaust of the main regulated pressure will be made through the quick exhaust R.

The use of a conventional silencer is recommended. Both solenoid valves assure the Filling or Emptying of the servo-chamber in order to increase or decrease the pressure at the outlet of the regulator.

In rest position of the valves all ports are blocked.

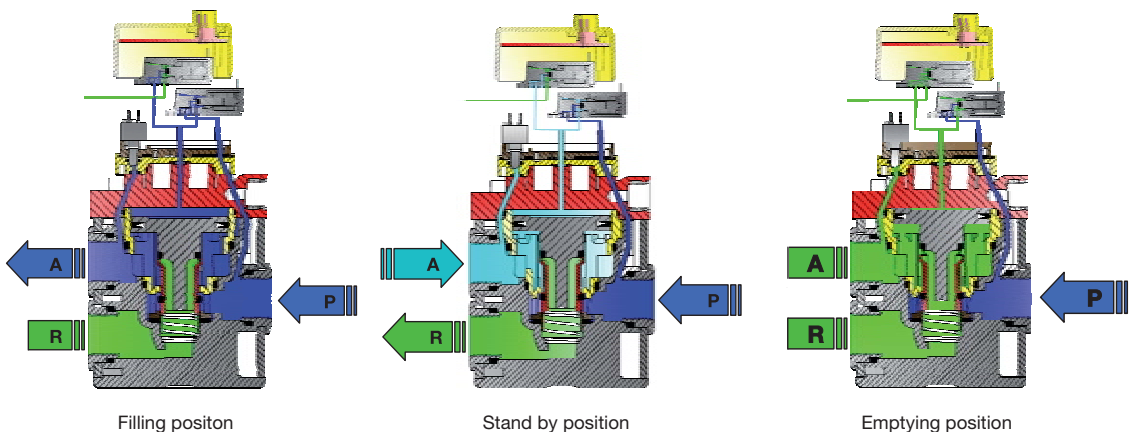

Block Diagram

The controller receives both the control signal (set pressure) and the feedback signal from the sensor (outlet pressure).

Any difference between the two amplifier inputs results in a corresponding output which drives the appropriate 2-way pulse width modulated solenoid valve so that the pilot piston moves to correct the pressure.

The same feedback signal from the sensor is used for the output feedback in voltage and current.

The digital signal (alarm) is activated when the conditions (out of pressure or time tolerance) are met.

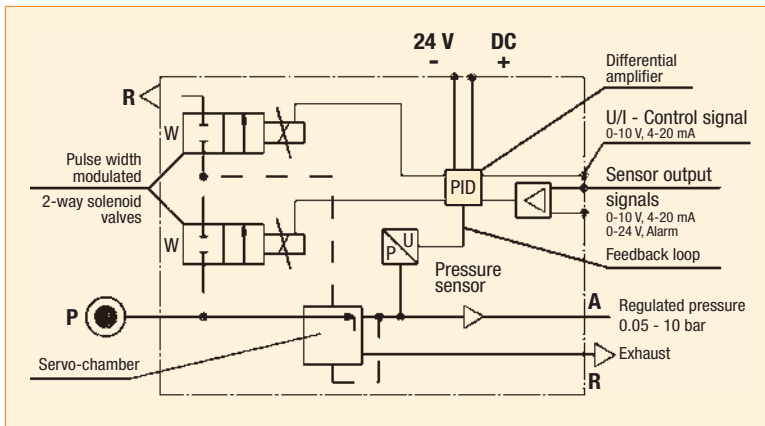

EPP4 possible executions : Basic and Comfort

EPP4 Basic and Comfort ranges share the same reliable mechanical parts. Proportional regulation is also identical for the two different executions, giving the same characteristics for hysteresis or precision for instance.

Comfort range regulators have a second M12 connector, that can be used to connect a remote display showing the current regulated pressure, or a PC to easily set the regulation's parameters. These are the key feature options for a comfortable use.

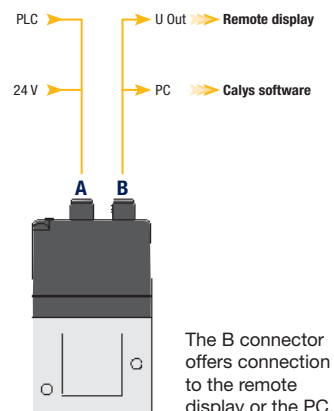

LUCIFER® EPP4 BASIC 1/4" & 1/2"

Basic	1/4" 1/2"
Comfort	1/4" 1/2"
Comfort	1/2" HP 1" 2"
Comfort ATEX	1/2" 1" 2"

TECHNICAL DATA

	Basic 1/4"	Basic 1/2"
Fluids:	Lubricated or non lubricated air and neutral gases Recommended filtration: 50 µm	
Temperature range:	Ambient: 0°C to +50°C Fluid: 0°C to +50°C	
Inlet pressure range: The inlet pressure must always be at least 1 bar above the regulated pressure.	1 to 12 bar	1 to 12 bar
Outlet pressure range:	0.05 to 10 bar	
Hysteresis:	± 50 mbar (factory set up)	
Air consumption at constant control signal:	0	
Supply voltage:	24 V DC ± 15% (Max. ripple 1 V)	
Power consumption:	Max. 2.8 W with 24 V DC and constant changes of the control signal < 1.5 W without change of control signal	
Control signal:	Analog 0 - 10 V Analog 4 - 20 mA	
Max. flow: Indicative response time: With a volume of 330 cm ³ at the outlet of the regulator	70 m ³ /h	150 m ³ /h
Filling 2 to 4 bar:	50 msec	60 msec
Filling 2 to 8 bar:	100 msec	120 msec
Emptying 4 to 2 bar:	70 msec	90 msec
Emptying 8 to 2 bar:	130 msec	190 msec
Safety position:	In case of control signal failure or if it is less than 50mV, the regulated pressure drops automatically to 0 bar (atmospheric pressure). In case of voltage supply failure, the regulated pressure will be kept constant.	
Electrical connection:	M12 - 4 pin; 4 x 0.34 mm ²	
Life expectancy:	> 50 Million changes of control signal steps	
Mounting position:	Indifferent (recommended position: upright; electronic part on top)	
Resistance to vibrations:	30 g in all directions	
Degree of protection:	IP 65	
Assembly:	Silicone free	
Electromagnetic compatibility: In accordance with:	EN 61000-6-1: 2001 EN 61000-6-2: 2001 EN 61000-6-3: 2001 EN 61000-6-4: 2001	
Installation and setting instructions:	See our "Notice 408038, 408014" and appendix supplied with the product.	

Note: Parker reserves the right to change specifications without notification.

LUCIFER® EPP4 BASIC 1/4" & 1/2"

FLOW CURVES

Flow Curve Basic 1/4"

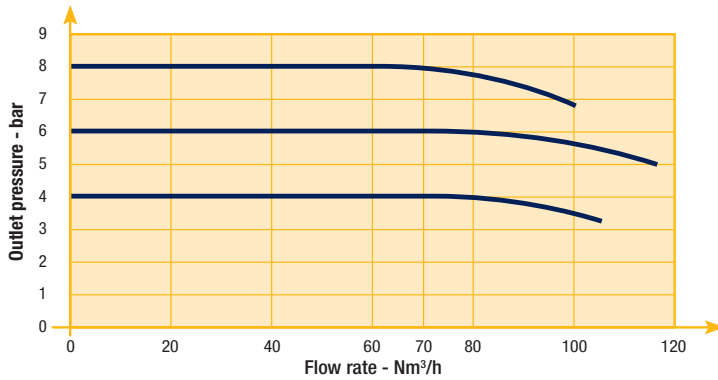

Flow Curve Basic 1/2"

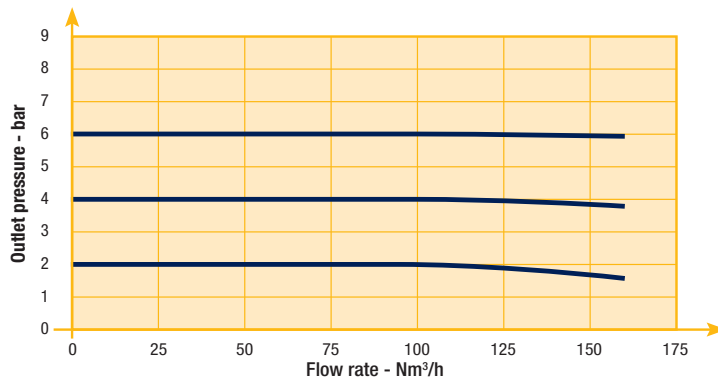

LUCIFER® EPP4 BASIC 1/4" & 1/2"

REFERENCES

Codes	Pipe	Pressure Range (bar)		Control Signal (see options)	Drawing Number
P4BG2001A001	G 1/4"	0	4 bar	4 - 20 mA	1
P4BG2001A002	G 1/4"	0	10 bar	0 - 10 V	1
P4BG2001A003	G 1/4"	0	10 bar	4 - 20 mA	1
P4BG2001A004	G 1/4"	0	6 bar	0 - 10 V	1
P4BG2001A005	G 1/4"	0	6 bar	4 - 20 mA	1
P4BG2001A006	G 1/4"	0	5 bar	0 - 10 V	1
P4BG2001A007	G 1/4"	0	5 bar	4 - 20 mA	1
P4BG2001A008	G 1/4"	0	7 bar	0 - 10 V	1
P4BG2001A009	G 1/4"	0	7 bar	4 - 20 mA	1
P4BG2003A002 *	G 1/4"	0	10 bar	0 - 10 V	1
P4BG2003A003 *	G 1/4"	0	10 bar	4 - 20 mA	1
P4BG4001A002	G 1/2"	0	10 bar	0 - 10 V	2
P4BG4001A003	G 1/2"	0	10 bar	4 - 20 mA	2
P4BG4001A004	G 1/2"	0	6 bar	0 - 10 V	2
P4BG4001A005	G 1/2"	0	6 bar	4 - 20 mA	2
P4BG4001A006	G 1/2"	0	5 bar	0 - 10 V	2
P4BG4001A007	G 1/2"	0	5 bar	4 - 20 mA	2
P4BG4001A008	G 1/2"	0	7 bar	0 - 10 V	2
P4BG4001A009	G 1/2"	0	7 bar	4 - 20 mA	2
P4BG4004A010 ***	G 1/2"	0	4 bar	0 - 10 V	2
P4BG4051A002 **	G 1/2"	0	10 bar	4 - 20 mA	2
P4BN2001A002	NPT 1/4"	0	10 bar	0 - 10 V	2
P4BN2001A003	NPT 1/4"	0	10 bar	4 - 20 mA	2
P4BN4001A002	NPT 1/2"	0	10 bar	0 - 10 V	2
P4BN4001A003	NPT 1/2"	0	10 bar	4 - 20 mA	2

* Integrated pilot exhaust

** O2

*** External pressure supply



LUCIFER® EPP4 BASIC 1/4" & 1/2"

DIMENSIONS DRAWINGS EPP4 BASIC 1/4"

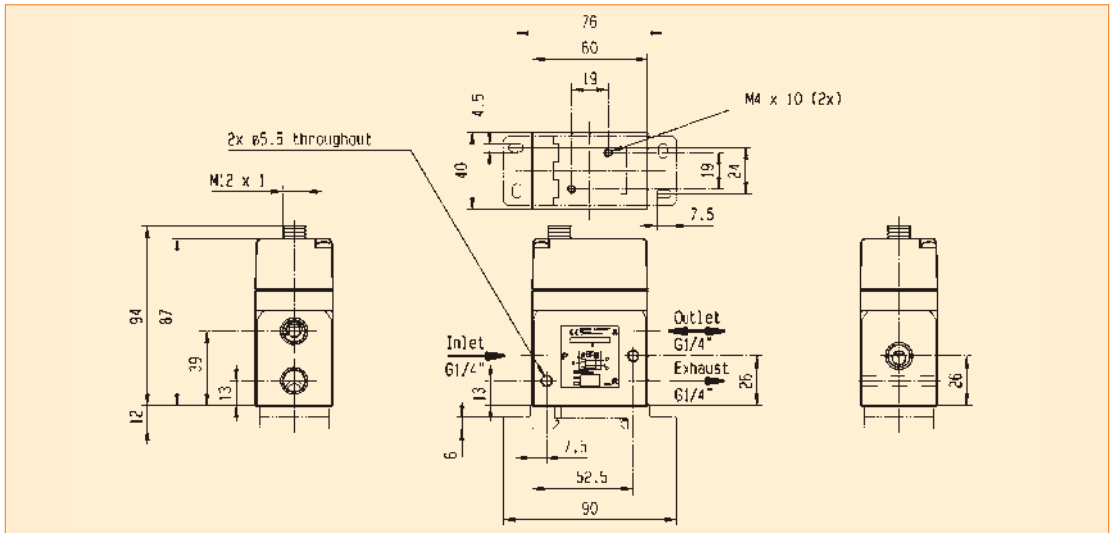

Drawing 1

DIMENSIONS DRAWINGS EPP4 BASIC 1/2"

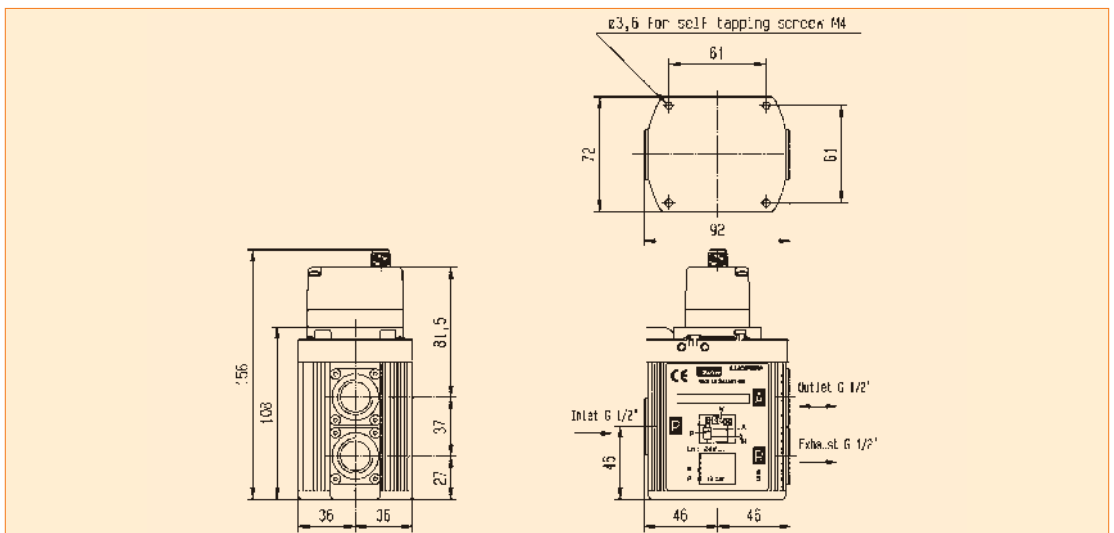

Drawing 2

LUCIFER® EPP4 COMFORT 1/4" & 1/2"

Basic	1/4" 1/2"
Comfort	1/4" 1/2"
Comfort	1/2" HP 1" 2"
Comfort ATEX	1/2" 1" 2"

TECHNICAL DATA

	Comfort 1/4"	Comfort 1/2"
Fluids:	Lubricated or non lubricated air and neutral gases - Recommended filtration: 50 µm	
Temperature range:	Ambient: 0°C to +50 °C Fluid: 0°C to +50 °C	
Inlet pressure range: The inlet pressure must always be at least 1 bar above the regulated pressure.	1 to 12 bar	1 to 12 bar
Outlet pressure range:	0.05 bis 10 bar	
Hysteresis:	± 50 mbar (factory set up)	
Air consumption at constant control signal:	0	
Supply voltage:	24 V DC ± 15 % (Max. ripple 1 V)	
Power consumption:	Max. 2.8 W with 24 V DC and constant changes of the control signal < 1.5 W without change of control signal	
Control signal:	Analog 0 - 10 V Analog 4 - 20 mA	
Outlet sensor signal:	Analog 0 - 10 V Standard for 0 - 10 bar; Adjustable Analog 4 - 20 mA Standard for 0 - 10 bar; Adjustable	Digital 0/24 V for alarm features: Adjustable pressure error (+/-) Adjustable delay ON Adjustable delay OFF Adjustable logic (+/-)
Max. flow:	70 m³/h	150 m³/h
Indicative response time:	With a volume of 330 cm³ at the outlet of the regulator	
Filling 2 to 4 bar :	50 msec	60 msec
Filling 2 to 8 bar:	100 msec	120 msec
Emptying 4 to 2 bar:	70 msec	90 msec
Emptying 8 to 2 bar:	130 msec	190 msec
Safety position:	In case of control signal failure or if it is less than 50 mV, the regulated pressure drops automatically to 0 bar (atmospheric pressure). In case of voltage supply failure, the regulated pressure will be kept constant.	
Electrical connection:	M12 - 8 pin; male connector power supply/control signal M12 - 5 pin; male connector communication	
Life expectancy:	> 50 Million changes of control signal steps	
Mounting position:	Indifferent (recommended position: upright; electronic part on top)	
Resistance to vibrations:	30 g in all directions	
Degree of protection:	IP 65	
Assembly:	Silicone free	
Electromagnetic compatibility: In accordance with:	EN 61000-6-1: 2001 EN 61000-6-2: 2001 EN 61000-6-3: 2001 + A11 2004 edition (01/07/07) EN 61000-6-4: 2001	
Installation and setting instructions:	See our "Notice 408128, 408134" and appendix supplied with the product.	

Note: Parker reserves the right to change specifications without notification.

LUCIFER® EPP4 COMFORT 1/4" & 1/2"

Flow Curves

Flow Curve 1/4"

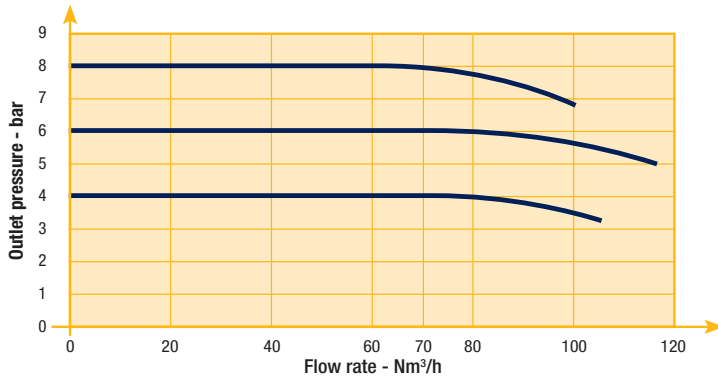

Flow Curve 1/2"

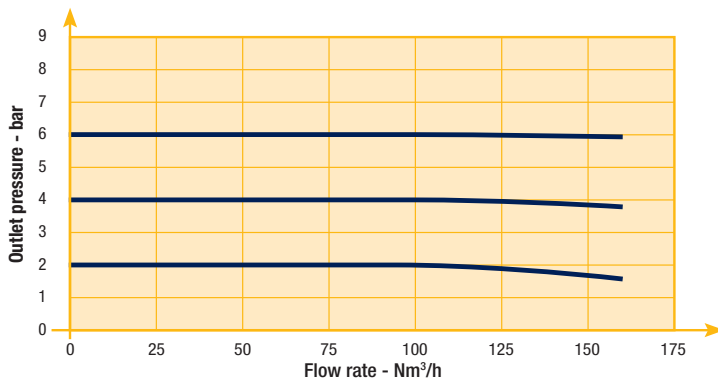

LUCIFER® EPP4 COMFORT 1/4" & 1/2"

REFERENCES

Codes	Pipe	Pressure Range (bar)		Control Signal (see options)	Display	Drawing Number
P4CG2001C001	G 1/4	0	10	0-10 V	-	3
P4CG2001C002	G 1/4	0	10	4-20 mA	-	3
P4CG2001C005	G 1/4	0	7	0-10 V	-	3
P4CG2001C006	G 1/4	0	7	4-20 mA	-	3
P4CG2002C001	G 1/4	0	10	0-10 V	included	3
P4CG2002C002	G 1/4	0	10	4-20 mA	included	3
P4CG2003C001 *	G 1/4	0	10	0-10 V	-	3
P4CG2003C002 *	G 1/4	0	10	4-20 mA	-	3
P4CG2002C007	G 1/4	0	7	0-10 V	-	3
P4CG2002C008	G 1/4	0	7	4-20 mA	-	3
P4CN2001C001	1/4 NPT	0	10	0-10 V	-	3
P4CN2001C002	1/4 NPT	0	10	4-20 mA	-	3
P4CN2002C001	1/4 NPT	0	10	0-10 V	included	3
P4CN2002C002	1/4 NPT	0	10	4-20 mA	included	3
P4CG4001C001	G 1/2	0	10	0-10 V	-	4
P4CG4001C002	G 1/2	0	10	4-20 mA	-	4
P4CG4001C005	G 1/2	0	7	0-10 V	-	4
P4CG4001C006	G 1/2	0	7	4-20 mA	-	4
P4CG4002C001	G 1/2	0	10	0-10 V	included	4
P4CG4002C002	G 1/2	0	10	4-20 mA	included	4
P4CG4002C005	G 1/2	0	7	0-10 V	-	4
P4CG4002C006	G 1/2	0	7	4-20 mA	-	4
P4CG4051C001 **	G 1/2	0	10	0-10 V	-	4
P4CG4051C002 **	G 1/2	0	10	4-20 mA	-	4
P4CN4001C001	1/2 NPT	0	10	0-10 V	-	4
P4CN4001C002	1/2 NPT	0	10	4-20 mA	-	4
P4CN4002C001	1/2 NPT	0	10	0-10 V	included	4
P4CN4002C002	1/2 NPT	0	10	4-20 mA	included	4

* Integrated pilot exhaust

** O2



LUCIFER® EPP4 COMFORT 1/4" & 1/2"

DIMENSIONS DRAWINGS EPP4 COMFORT RANGE 1/4"

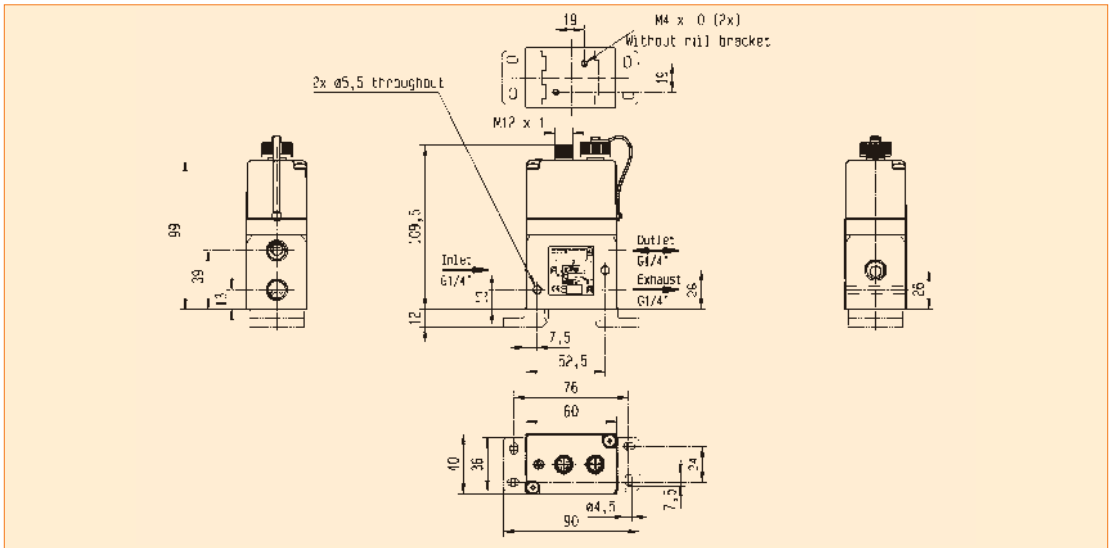

Drawing 3

DIMENSIONS DRAWINGS EPP4 COMFORT RANGE 1/2"

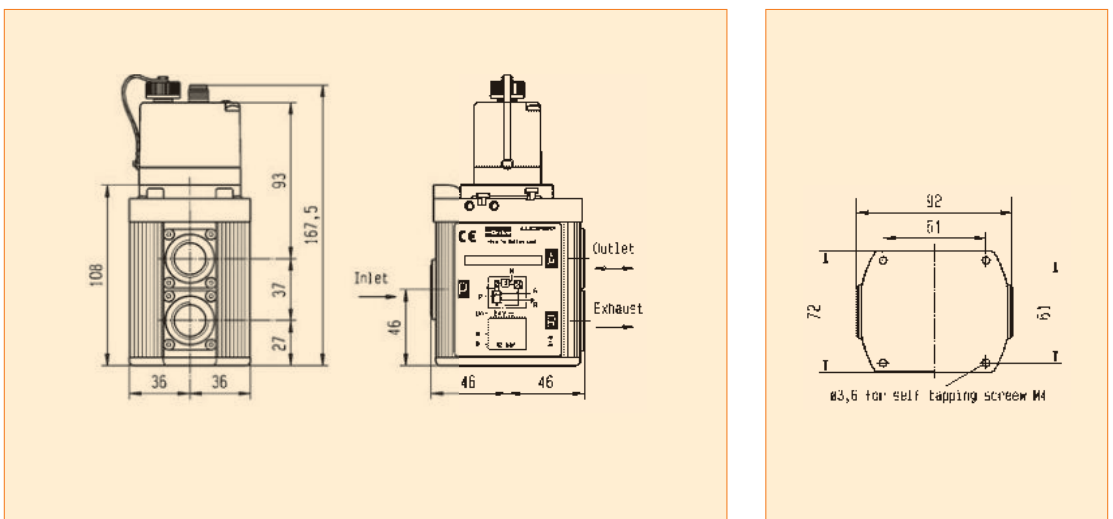

Drawing 4

LUCIFER® EPP4 COMFORT 1/2"HP, 1" & 2"

Basic	1/4" 1/2"
Comfort	1/4" 1/2"
Comfort	1/2" HP 1" 2"
Comfort ATEX	1/2" 1" 2"

TECHNICAL DATA

	Comfort 1/2" HP	Comfort 1"	Comfort 2"
Fluids:	Lubricated or non lubricated air and neutral gases - Recommended fi ltration: 50 µm		
Temperature range:	Ambient: 0°C to +50°C Fluid: 0°C to +50°C		
Inlet pressure range: The inlet pressure must always be at least 1 bar above the regulated pressure.	1 to 21 bar	1 to 21 bar	1 to 12 bar
Outlet pressure range:	0.05 to 20 bar	0.05 to 20 bar	0.05 to 10 bar
Hysteresis:	≤ 100 mbar if P inlet ≤ 10 bar ≤ 200 mbar if P inlet > 10 bar		
Air consumption at constant control signal:	0		
Supply voltage:	24V DC ± 15%		
Power consumption:	Max. 6 W with 24 V DC and constant changes of the control signal < 2 W without change of control signal		
Control signal:	Analog 0 - 10 V Analog 4 - 20 mA		
Outlet sensor signal:	Analog 0 - 10 V Standard for 0 - 10 bar; Adjustable	Digital 0/24 V for alarm features: Adjustable pressure error (+/-) Adjustable delay ON Adjustable delay OFF Adjustable logic (+/-)	
	Analog 4 - 20 mA Standard for 0 - 10 bar; Adjustable		
Max. flow:	150 m³/h	1 000 m³/h	2 700 m³/h
Indicative response time:	With a volume of 330 cm³ at the outlet of the regulator		
Filling 2 to 8 bar:	120 msec	250 msec	250 msec
Emptying 8 to 2 bar:	190 msec	400 msec	400 msec
Safety position:	In case of control signal failure or if it is less than 50 mV, the regulated pressure drops automatically to 0 bar atmospheric pressure (for pressure ranges from 0-10 bar, 100 mV for pressure range over 10 bar). In case of voltage supply failure, the regulated pressure will be kept constant.		
Electrical connection:	M12 - 8 pin; male connector power supply/control signal M12 - 5 pin; male connector communication		
Life expectancy:	> 20 Million changes of control signal steps		
Mounting position:	Indifferent (recommended position: upright; electronic part on top)		
Resistance to vibrations:	30 g in all directions		
Degree of protection:	IP 65		
Assembly:	Silicone free		
Electromagnetic compatibility: In accordance with:	EN 61000-6-1: 2001 EN 61000-6-2: 2001 EN 61000-6-3: 2001 + A11 2004 edition (01/07/07) EN 61000-6-4: 2001		
Installation and setting instructions:	See our "408 193" and appendix supplied with the product.		

Note: Parker reserves the right to change specifications without notification.

LUCIFER® EPP4 COMFORT 1/2"HP, 1" & 2"

FLOW CURVES



Flow Curve 1/2"HP

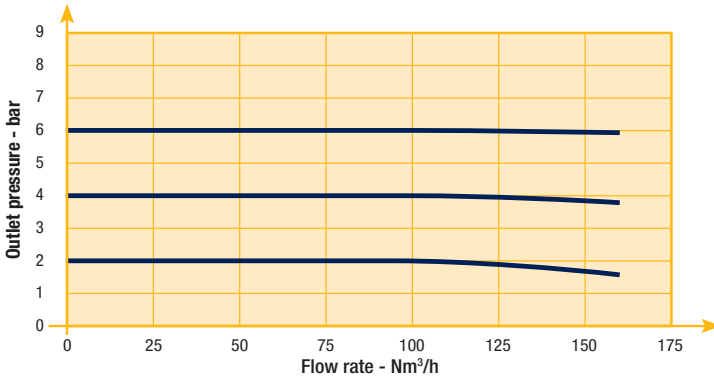

Flow Curve 1"

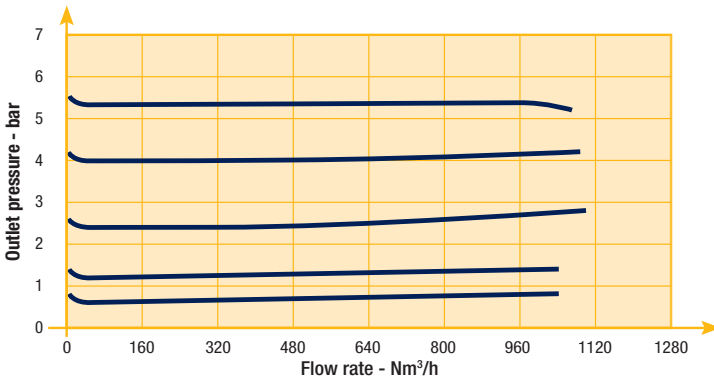

Flow Curve 2"

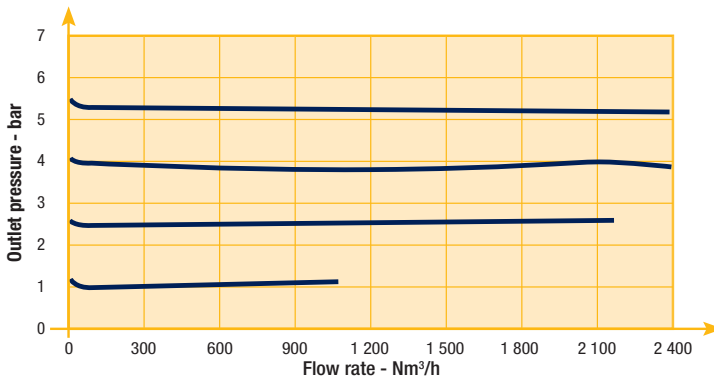

LUCIFER® EPP4 COMFORT 1/2"HP

REFERENCES

Codes	Pipe	Max inlet pressure (bar)	Pressure range (bar)		Control signal (see options)	Dimensional Drawing
P4CG4101D001	G1/2	15	0	12	0-10 V	5
P4CG4201D005	G1/2	21	0	16	0-10 V	6
P4CG4201D003	G1/2	21	0	20	0-10 V	6
P4CG4201D004	G1/2	21	0	20	4-20 mA	6

Other specific settings or specialties are available, please contact us.



LUCIFER® EPP4 COMFORT 1/2"HP

DIMENSIONS DRAWINGS

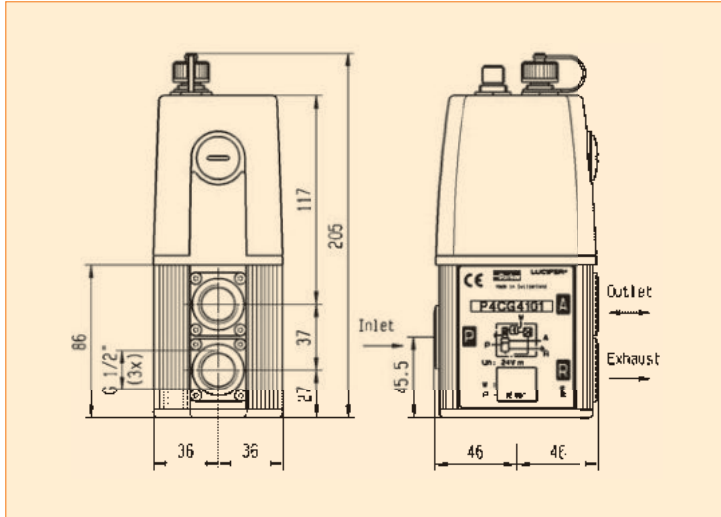

Drawing 5

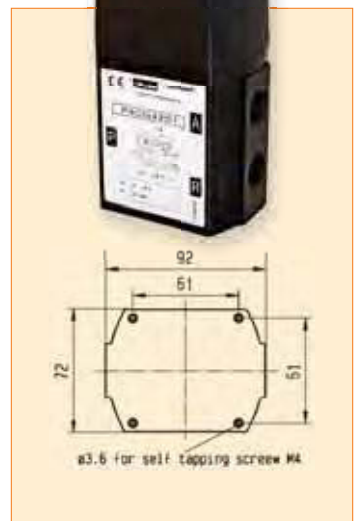
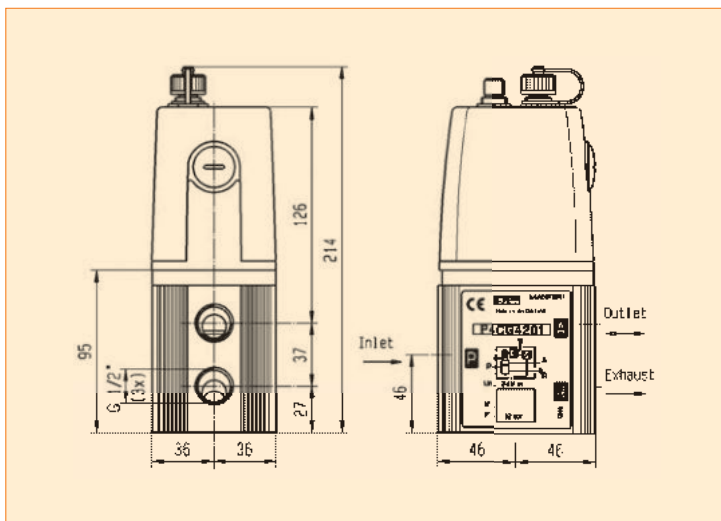

Drawing 6

LUCIFER® EPP4 COMFORT 1" & 2"

REFERENCES

Codes	Pipe	Max inlet pressure (bar)	Pressure range (bar)		Control signal (see options)	Dimensional Drawing
P4CG6101C009	G1	12	0	3.5	4-20 mA	7
P4CG6101C011	G1	12	0	5.0	0-10 V	7
P4CG6101C010	G1	12	0	6.0	4-20 mA	7
P4CG6101C001	G1	12	0	10	0-10 V	7
P4CG6101C002	G1	12	0	10	4-20 mA	7
P4CG6201D001	G1	21	0	12	0-10 V	7
P4CG6201D003	G1	21	0	20	0-10 V	7
P4CG9101C012	G2	12	0	4.0	4-20 mA	8
P4CG9101C010	G2	12	0	6.0	4-20 mA	8
P4CG9101C001	G2	12	0	10	0-10 V	8
P4CG9101C002	G2	12	0	10	4-20 mA	8

Other specific settings or specialties are available, please contact us.

LUCIFER® EPP4 COMFORT 1" & 2"

DIMENSIONS DRAWINGS EPP4 COMFORT RANGE 1"

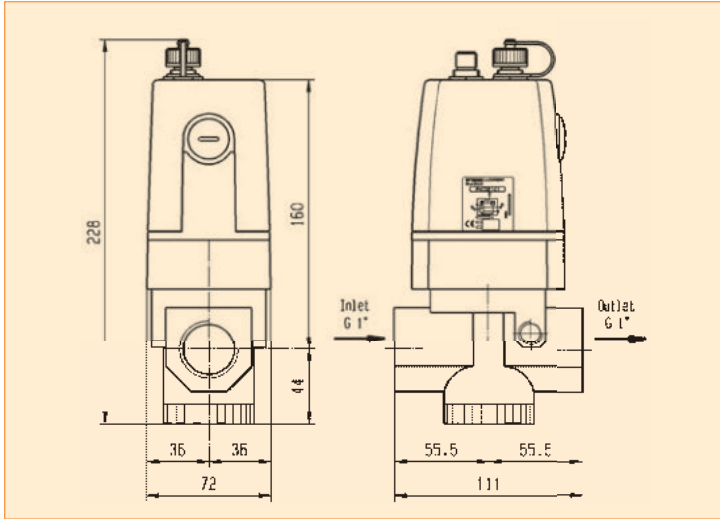

Drawing 7



DIMENSIONS DRAWINGS EPP4 COMFORT RANGE 2"

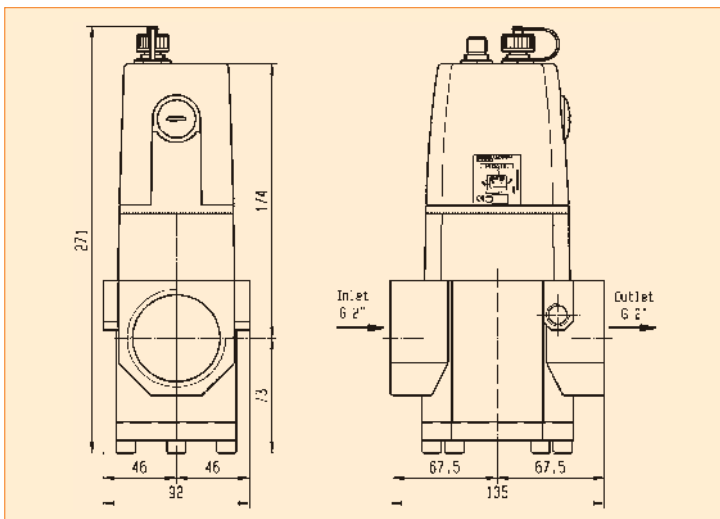

Drawing 8



LUCIFER® EPP4 COMFORT 1/2", 1" & 2" ATEX



Basic	1/4" 1/2"
Comfort	1/4" 1/2"
Comfort	1/2" HP 1" 2"
Comfort ATEX	1/2" 1" 2"

TECHNICAL DATA

	Comfort 1/2" ATEX	Comfort 1" ATEX	Comfort 2" ATEX
Fluids:	Lubricated or non lubricated air and neutral gases - Recommended filtration: 50 µm		
Temperature range:	Ambient: 0°C to +50°C Fluid: 0°C to +50°C		
Inlet pressure range: The inlet pressure must always be at least 1 bar above the regulated pressure.	Inlet pressure range: 1 to 12 bar		
Outlet pressure range:	Outlet pressure range: 0.05 to 10 bar		
Hysteresis:	≤ 100 mbar		
Air consumption at constant control signal:	0		
ATEX certification:	Ex II 3 G/D Ex nA IIC T4 Gc Ex tc IIIB T130°C Dc		
Supply voltage:	24V DC ± 15 %		
Power consumption:	Max. 6 W with 24 V DC and constant changes of the control signal < 2 W without change of control signal		
Control signal:	Analog 0 - 10 V Analog 4 - 20 mA		
Outlet sensor signal:	Analog 0 - 10 V Standard for 0 - 10 bar; Adjustable	Digital 0/24 V for alarm features: Adjustable pressure error (+/-) Adjustable delay ON Adjustable delay OFF Adjustable logic (+/-)	
	Analog 4 - 20 mA Standard for 0 - 10 bar; Adjustable		
Max. flow:	150 m³/h	1 000 m³/h	2 700 m³/h
Indicative response time:	With a volume of 330 cm³ at the outlet of the regulator		
Filling 2 to 8 bar:	120 msec	250 msec	250 msec
Emptying 8 to 2 bar:	190 msec	400 msec	400 msec
Safety position:	In case of control signal failure or if it is less than 50 mV, the regulated pressure drops automatically to 0 bar atmospheric pressure (for pressure ranges from 0-10 bar, 100 mV for pressure range over 10 bar). In case of voltage supply failure, the regulated pressure will be kept constant.		
Electrical connection:	M12 - 8 pin; male connector power supply/control signal M12 - 5 pin; male connector communication		
Life expectancy:	> 20 Million changes of control signal steps		
Mounting position:	Indifferent (recommended position: upright; electronic part on top)		
Resistance to vibrations:	30 g in all directions		
Degree of protection:	IP 54		
Assembly:	Silicone free		
Electromagnetic compatibility: In accordance with:	EN 61000-6-1: 2001 EN 61000-6-2: 2001 EN 61000-6-3: 2001 + A11 2004 edition (01/07/07) EN 61000-6-4: 2001		
Installation and setting instructions:	See our "408 283" and appendix supplied with the product.		

Note: Parker reserves the right to change specifications without notification.

LUCIFER® EPP4 COMFORT 1/2", 1" & 2" ATEX



FLOW CURVES

Flow Curve 1/2"

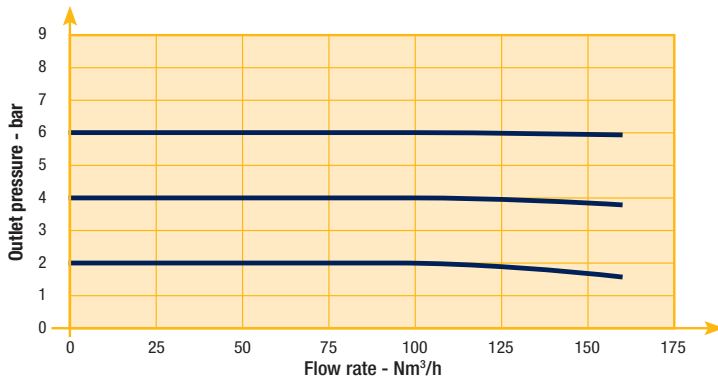

Flow Curve 1"

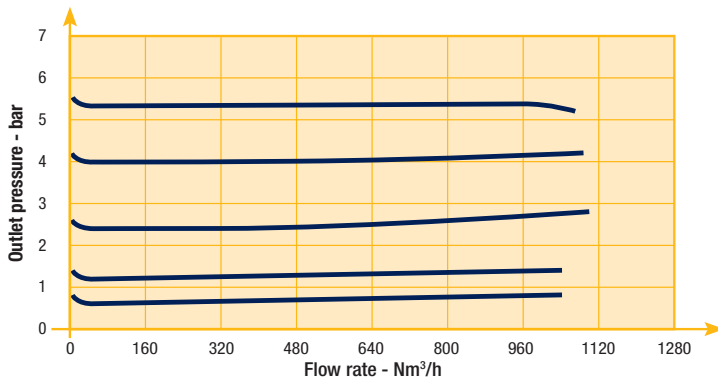

Flow Curve 2"

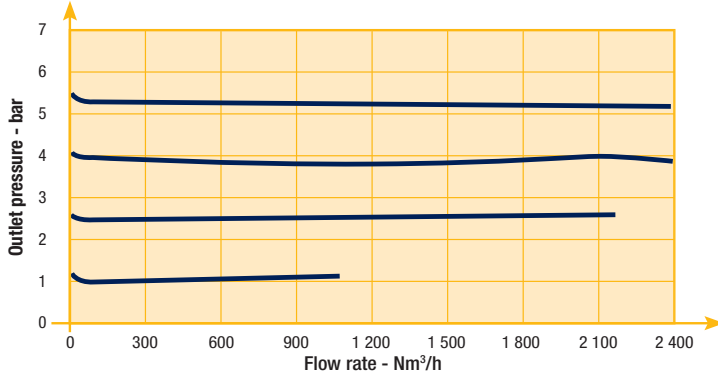

LUCIFER® EPP4 COMFORT 1/2" ATEX



REFERENCES

Codes	Pipe	Max inlet pressure (bar)	Pressure range (bar)		Control signal (see options)	Dimensional Drawing
P4CG4461C001	G1/2	12	0	10	0-10 V	9
P4CG4461C002	G1/2	12	0	10	4-20 mA	9
P4CG4465C001 **	G1/2	12	0	10	0-10 V	9
P4CG4465C002 **	G1/2	12	0	10	4-20 mA	9

** O2

Other specific settings or specialties are available, please contact us.



LUCIFER® EPP4 COMFORT 1/2" ATEX



DIMENSIONS DRAWINGS

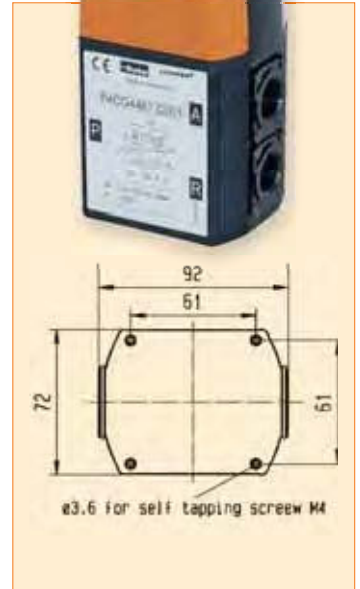
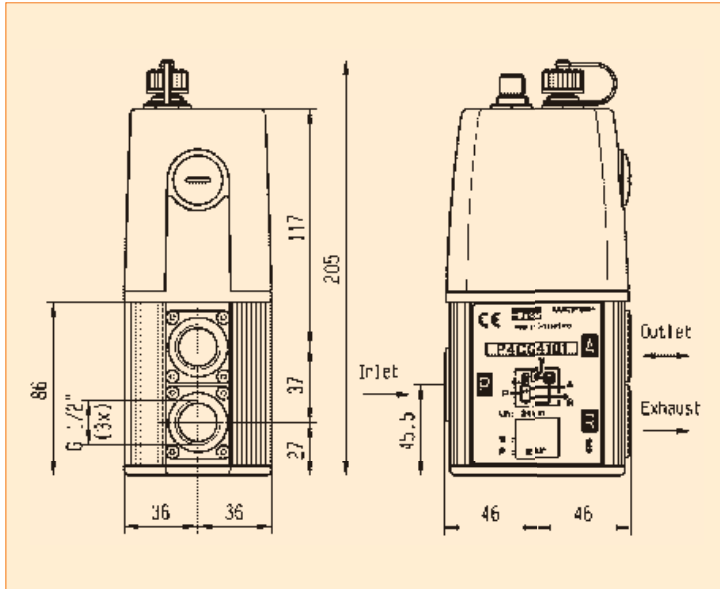

Drawing 9

LUCIFER® EPP4 COMFORT 1" & 2" ATEX



REFERENCES

Codes	Pipe	Max inlet pressure (bar)	Pressure range (bar)		Control signal (see options)	Dimensional Drawing
P4CG6161C001	G1	12	0	10	0-10 V	11
P4CG6161C002	G1	12	0	10	4-20 mA	11
P4CG9161C001	G2	12	0	10	0-10 V	12
P4CG9161C002	G2	12	0	10	4-20 mA	12

Other specific settings or specialties are available, please contact us.

LUCIFER® EPP4 COMFORT 1" & 2" ATEX



DIMENSIONS DRAWINGS EPP4 COMFORT RANGE 1"

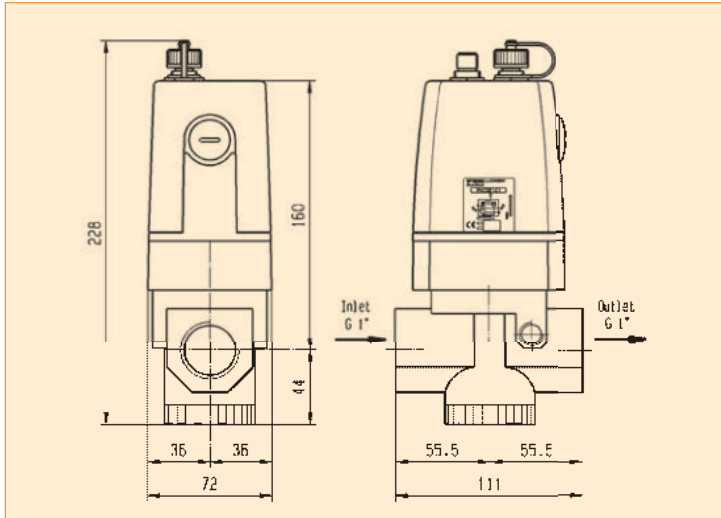

Drawing 11

DIMENSIONS DRAWINGS EPP4 COMFORT RANGE 2"

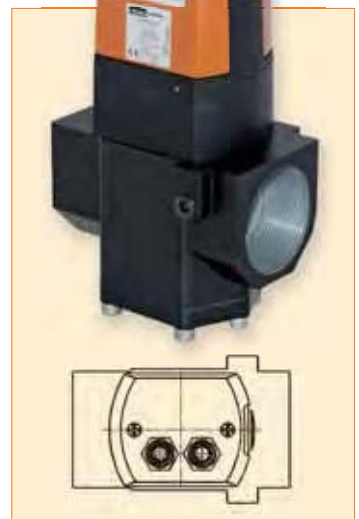
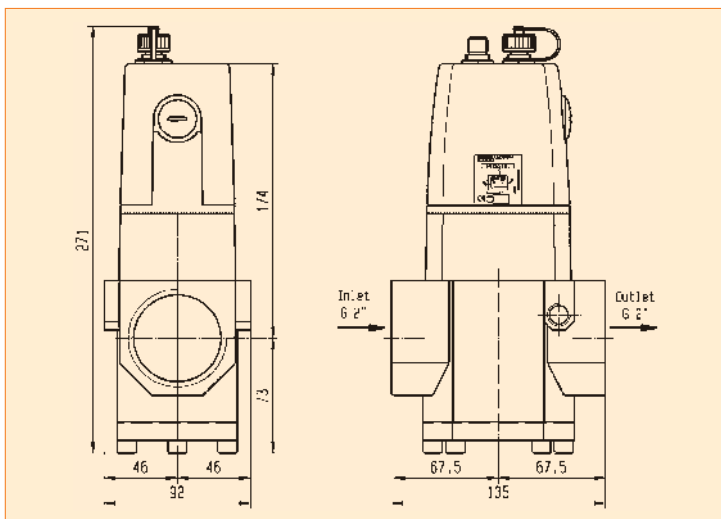

Drawing 12

LUCIFER® EPP4 ACCESSORIES

MOUNTING BRACKETS FOR EPP4 1/4" BASIC / COMFORT



This mounting bracket is delivered as a standard with all EPP4 1/4".

LUCIFER® EPP4 ACCESSORIES

MOUNTING BRACKETS FOR EPP4 1/2" BASIC / COMFORT

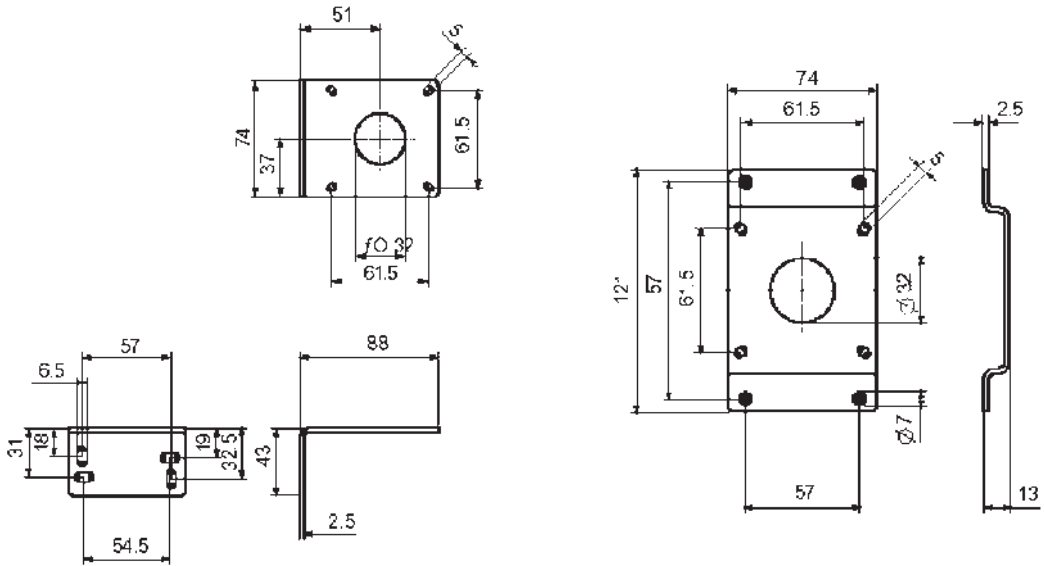

Order reference 491367



Order reference 491366

LUCIFER® EPP4 ACCESSORIES

POWER SUPPLY/CONTROL SIGNAL CABLE FOR BASIC AND COMFORT VERSIONS.

Cable for Basic EPP4

- 2 m cable with moulded straight M12-4 pole

Order Ref. P8L-MC04A2A-M12

Cable for Comfort EPP4

- 2 m cable with moulded straight M12-8 pole

Order Reference 496796

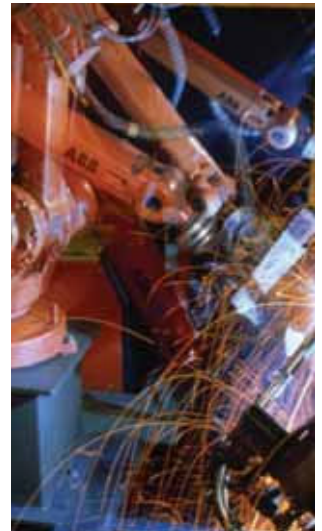

LUCIFER® EPP4 COMFORT ACCESSORIES

calys SOFTWARE

Calys is a unique software in house developed to configure all the parameters of the EPP4 Comfort range. Calys is an option of the EPP4. A specific cable is needed for the communication between the EPP4 and a PC.



Calys offers many capabilities:

- Live monitoring (control signal, regulated pressure, supply voltage,...)
- Recording of the main parameters (control signal, regulated pressure, supply voltage,...) in an Excel file
- Free calibration for the inputs and outputs
- Adjustable alarm (positive-negative, pressure limits, delays)
- Configuration files easy to duplicate
- Complete and interactive help file
- Data in 4 different pressure units
- Menus in 4 languages (English, German, French and Italian)

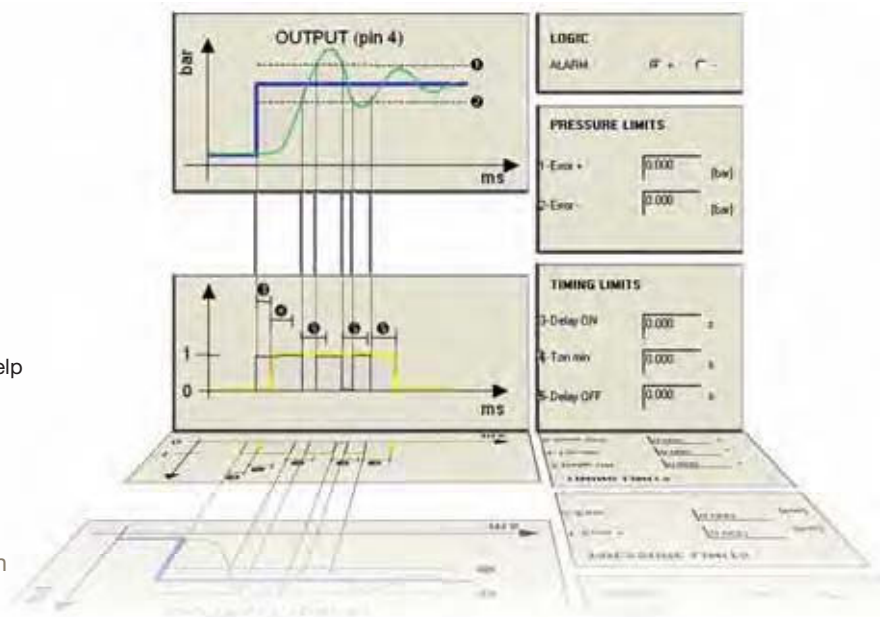

Specific communication cable PC-EPP4 with RS232 and USB connection

Order Reference 496449

This option is for safe area only.

To download free Calys software click on www.parker.com/FCDE/Support

LUCIFER® EPP4 COMFORT ACCESSORIES

REMOTE DISPLAY

This option includes the Remote Display and 1.5 meter connecting cable. Connected to the pressure regulator, it offers flexible monitoring. This option only works with EPP4 0-10 bar.

Compact and highly readable remote LED display:

- Bar and PSI scales
- Security lock
- 1.5 m cable
- Mounting brackets



**Order the Remote Display
under reference 496490**

This option is for safe area only.

PANEL MOUNTING KIT

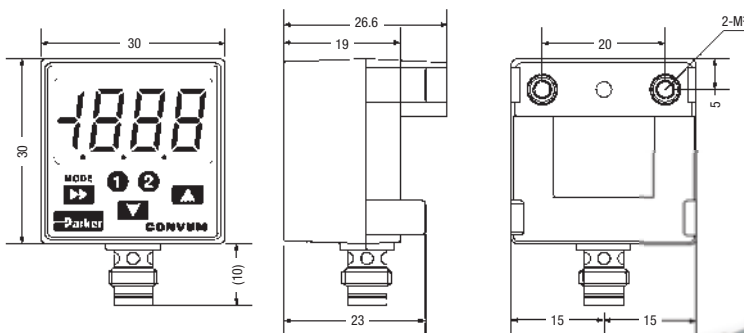

**Order the Panel Mounting
Kit under reference 496601**

COILS, HOUSINGS & ELECTRICAL PARTS

A COMPLETE RANGE OF COILS, HOUSINGS
AND ELECTRICAL PARTS FOR SOLENOID VALVES



DEFINITIONS

HOUSINGS OR COIL ASSEMBLY KITS, COILS AND ELECTRICAL PARTS



Housing:

We define a **housing** as the combination of the fixing elements including the nameplate **1**, the cover **2** or the subplate **6** and the envelope itself **4** or **5** which protects the coil and its electrical components. The housings may be made of metal or plastic material.

Coil assembly kit:

The coil assembly kit **7** or **9** is the set comprising a plate, washer and nut. Sometimes coil assembly kits consist only of a nut or a special fixing device.

Coil:

This consists of the winding and its plastic moulding. There are three different types of coils distinguished by their shape and dimensions: 40 mm **3**, 32 mm **8** and 22 mm **10**.

Electric part:

The electric part is the set comprising the housing, the assembly kit and the coil.

Attention:

Any Parker FCDE coil or electrical part may be energised only when mounted on a valve. Otherwise there is a risk of damaging the product and its surroundings (overheating, explosion, fire, etc.).

TABLE OF CONTENT

INTRODUCTION

Index for Explosion Proof Electrical Parts.....	442
List of Coil Groups	443

COILS

Coils for DIN plug connection.....	446
Coils with flying leads.....	469
Coils with screw terminal.....	474
Coils with ISO-DIN connector.....	481

EXPLOSION PROOF ELECTRICAL PARTS

Level of protection "nAc nCc"	484
Level of protection "db"	492
Level of protection "mb".....	494
Level of protection "db mb".....	499
Level of protection "eb"	504
Level of protection "eb mb".....	505
Level of protection "ia"	508

HOUSINGS	518
-----------------------	-----

COIL ACCESSORIES	522
-------------------------------	-----

EXPLOSIVE ENVIRONMENTS	524
-------------------------------------	-----

COIL APPENDICES

Guidance chart for IS-Barriers.....	534
-------------------------------------	-----

INDEX FOR EXPLOSION PROOF ELECTRICAL PARTS

Coil Reference	Coil Group	Designation	Power DC Pn (W)	Power AC Pn (W)	Ambient Temperature	UL	Degree of Protection	ATEX or NEMA 4X Protection (Gas)	Page
496637	1.2	Explosion proof electrical part "nAc nCc", 22 mm, double frequency	3.0	3.0	-20°C to +50°C	-	IP65	II 3 D Ex tc IIC T 95°C	485
495880	2.0/2.2	Explosion proof electrical part "nAc nCc", 32 mm	14.0	14.0	-40°C to +50°C	-	IP65	II 3 G Ex nAc nCc IIC T3	489
496155	2.0/2.2	Explosion proof increased safety electrical part "nAc nCc", 50 mm	14.0	14.0	-40°C to +65°C	-	IP67	II 3 G Ex nAc nCc IIC T3	491
495915	4.0	Explosion proof increased safety electrical part "nAc nCc", 50 mm	13.0	11.0	-40°C to +65°C	-	IP67	II 3 G Ex nAc nCc IIC T3	490
495870	2.0/2.1	Explosion proof electrical part "nAc nCc", 32 mm	9.0	8.0	-40°C to +50°C	-	IP65	II 3 G Ex nAc nCc IIC T3/T4	486
495875	3.0	Explosion proof electrical part "nAc nCc", 32 mm	7.0	6.0	-40°C to +50°C	-	IP65	II 3 G Ex nAc nCc IIC T3/T4	488
496110	2.0/2.1	Explosion proof electrical part "nAc nCc", 32 mm	-	9.0	-40°C to +50°C	-	IP65	II 3 G Ex nAc nCc IIC T3/T4	486
495865	1.1	Explosion proof electrical part "nAc nCc", low power, 22 mm	2.5	2.0	-40°C to +50°C	-	IP65	II 3 G Ex nAc nCc IIC T5	484
496125	6.0	Explosion proof electrical part "nAc nCc", low power, 32 mm	1.6	-	-40°C to +50°C	-	IP65	II 3 G Ex nAc nCc IIC T5/T6	487
492670	2.0/2.1	Explosion proof encapsulated electrical part "mb", 32 mm	9.0	8.0	-40°C to +50°C	-	IP65	II 2 G Ex mb IIC T4	495
482605	1.1	Explosion proof encapsulated electrical part "mb", 32 mm	5.0	4.0	-40°C to +65°C	-	IP65	II 2 G Ex mb IIC T4/T5	494
482606	1.1	Explosion proof encapsulated electrical part "mb", low power, 32 mm	2.5	2.0	-40°C to +65°C	-	IP65	II 2 G Ex mb IIC T4/T5	494
492070	2.0/2.1	Explosion proof encapsulated electrical part "mb", with water proof metal housing, 50 mm	8.0	9.0	-40°C to +65°C	-	IP67	II 2 G Ex mb IIC T4/T5	496
HZ10	2.0/2.1	Explosion proof encapsulated electrical part "mb", double frequency	8.0	8.0	-40°C to +85°C	-	IP65	II 2 G - Ex mb IIC T3/T4/T5	497
HZ11	2.0/2.2	Explosion proof encapsulated electrical part "mb", double frequency	14.0	14	-40°C to +85°C	-	IP65	II 2 G - Ex mb IIC T3/T4/T5	498
483270	11.0	Flame proof electrical part "db", 50 mm	8.0	8.0	-40°C to +80°C	-	IP66	II 2 G Ex db IIC T4/T5/T6	492
497105	10.3	Flame proof electrical part "db", 50 mm	8.0	8.0	-50°C to +80°C	-	IP66	II 2 G Ex db IIC T4/T5/T6	493
493640	2.0/2.1	Flame proof encapsulated electrical part "db mb", double frequency	8.0	8.0	-40°C to +75°C	-	IP65	II 2 G Ex db mb IIC T4/T5	503
495905	2.0/2.1	Flame proof encapsulated electrical part "db mb", 37 mm	8.0	8.0	-40°C to +65°C	-	IP67	II 2 G Ex db mb IIC T4	500
496560	10.1	Flame proof encapsulated electrical part "db mb", 37 mm	8.0	8.0	-40°C to +65°C	-	IP67	II 2 G Ex db mb IIC T4	501
496800	10.1	Flame proof encapsulated electrical part "db mb", 37 mm	8.0	8.0	-40°C to +65°C	-	IP67	II 2 G Ex db mb IIC T4	502
495900	6.0	Flame proof encapsulated electrical part "db mb", low power, 37 mm	2.0	2.5	-40°C to +65°C	-	IP67	II 2 G Ex db mb IIC T4/T5/T6	499
496555	10.2	Flame proof encapsulated electrical part "db mb", 37 mm	6.0	6.0	-40°C to +65°C	-	IP67	II 2 G Ex db mb IIC T4/T5/T6	501
496700	10.2	Flame proof encapsulated electrical part "db mb", 37 mm	6.0	6.0	-40°C to +65°C	-	IP67	II 2 G Ex db mb IIC T4/T5/T6	502
494040	2.0/2.1	Explosion proof increased safety electrical part "eb", 50 mm	8.0	8.0	-40°C to +90°C	-	IP67	II 2 G Ex eb IIC T3/T4	504
483371	2.0/2.1	Explosion proof increased safety electrical part "eb", 50 mm	8.0	8.0	-40°C to +65°C	-	IP67	II 2 G Ex eb IIC T4	504
492190	2.0/2.1	Explosion proof increased safety and encapsulated elect. part "eb", 50 mm	9.0	11.0	-40°C to +75°C	-	IP66	II 2 G Ex eb mb IIC T3/T4	507
492310	10.1	Explosion proof increased safety and encapsulated electrical part "eb", 50 mm	6.0	6.0	-40°C to +75°C	-	IP66	II 2 G Ex eb mb IIC T4/T5	505
492210	9.0	Explosion proof increased safety and encapsulated electrical part "eb", "Booster", 50 mm	1.0 to 1.8	-	-40°C to +75°C	-	IP66	II 2 G Ex eb mb IIC T5/T6	506
495910	8.0	Explosion proof intrinsically safe electrical part "ia", "booster", 37 mm	0.3 to 1.2	-	-40°C to +80°C	-	IP67	II 1 G Ex ia IIC T4/T5/T6	509
496565	9.0	Explosion proof intrinsically safe electrical part "ia", "Booster", 37 mm	0.77 to 2.58	-	-40°C to +80°C	-	IP67	II 1 G Ex ia IIC T4/T5/T6	510
483580.01	7.0	Explosion proof intrinsically safe electrical part "ia", 32 mm	3.0	-	-40°C to +55°C	-	IP65	II 1 G Ex ia IIC T6	508
488650.01	7.0	Explosion proof intrinsically safe electrical part "ia", 50 mm	0.3 to 3.0	-	-40°C to +65°C	-	IP66	II 1 G Ex ia IIC T6	513
488660.01	7.0	Explosion proof intrinsically safe electrical part "ia", 50 mm	3.0	-	-40°C to +65°C	-	IP67	II 1 G Ex ia IIC T6	514
488670.01	7.0	Explosion proof intrinsically safe electrical part "ia", 50 mm	0.3 to 3	-	-40°C to +65°C	-	IP65	II 1 G Ex ia IIC T6	515
492965.01	9.0	Explosion proof intrinsically safe electrical part "ia", "Booster", 50 mm	0.3 to 2.3	-	-40°C to +65°C	-	IP66	II 1 G Ex ia IIC T6	511
482870.01	12.0	Explosion proof intrinsically safe electrical part "ia", 50 mm	3.0	-	-40°C to +65°C	-	IP66	II 1 G Ex ia IIC T6	512
490885	7.0	Explosion proof intrinsically safe electrical part, "NEMA", 50 mm	3.0	-	-40°C to +60°C	-	NEMA 4 - 4X	Cl. I, Div.I, Gr. A, B, C, D	513
490890	7.0	Explosion proof intrinsically safe electrical part, "NEMA", 50 mm	3.0	-	-40°C to +60°C	-	NEMA 4 - 4X	Cl. I, Div.I, Gr. A, B, C, D	514
492335	12.0	Explosion proof intrinsically safe electrical part, "NEMA", 50 mm	3.0	-	-40°C to +60°C	-	NEMA 4 - 4X	Cl. I, Div.I, Gr. A, B, C, D	512

LIST OF COIL GROUPS

Parker coils and electrical parts are classified by groups determining their compatibility with Parker solenoid valves.

Group	For application with
1.1	Standard valves or on 2000 Series with standard pilot
1.2	Standard valves or on 2000 Series for high flow
1.3	Standard valves or on 2000 Series of W coil
2.0	Standard valves or on 7000 Series with standard pilot
2.1	Standard valves or on 7000 Series, for coils 8 - 9 W
2.2	Standard valves or on 7000 Series, for coils 14 W
3.0	Standard valves or on 7000 Series with reduced power
4.0	Standard valves or on 7000 Series, for bistable (Impulse) coils or electrical parts
6.0	Special valves "97" or on 7000 Series, for Intrinsically safe coils or electrical parts
7.0	Special valves "90", for coils and intrinsically safe electrical parts
8.0	Special valves "97" or on 7000 Series, for Intrinsically safe coils or electrical parts with booster
9.0	Special valves "xx" or on 9000 Series, for Intrinsically safe coils or electrical parts with booster
10.1	Standard valves or on 9000 Series with standard pilot
10.2	Standard valves or on 9000 Series "db mb"
10.3	Special valves or on 8000 Series "d"
11.0	Standard valves or on 9000 Series "1D"
12.0	Standard valves or on 9000 Series with manual reset
13.0	Special valves or on 7000 Series for Transportation
14.1	Special valves or on 7000 Series for Oil Burners
14.2	Special valves or on 7000 Series for Oil Burners
14.3	Special valves or on 7000 Series for Oil Burners
20.1	Standard valves or on 7000 Series for Z-Y coil
20.2	Standard valves or on 7000 Series for Z-Y "High Power" coil
21.0	Standard valves or on 7000 Series for J-B coil
22.0	Standard valves for KP-KT-KH coil
23.0	Standard valves for XP-XT coil for Oil Burners
24.0	Standard valves for Liquepure coils for Beverage Dispensing

TABLE OF CONTENT

INTRODUCTION

Index for Explosion Proof Electrical Parts.....	442
List of Coil Groups.....	443

COILS

Coils for DIN plug connection.....	446
Coils with flying leads.....	469
Coils with screw terminal.....	474
Coils with ISO-DIN connector.....	481

EXPLOSION PROOF ELECTRICAL PARTS

Level of protection "nAc nCc".....	484
Level of protection "db".....	492
Level of protection "mb".....	494
Level of protection "db mb".....	499
Level of protection "eb".....	504
Level of protection "eb mb".....	505
Level of protection "ia".....	508

HOUSINGS.....	518
---------------	-----

COIL ACCESSORIES.....	522
-----------------------	-----

EXPLOSIVE ENVIRONMENTS.....	524
-----------------------------	-----

COIL APPENDICES

Guidance chart for IS-Barriers.....	534
-------------------------------------	-----



COILS 32 mm

These coils can be mounted with every Parker solenoid valves corresponding to the specified Coil Group. See column "Coil Group" within valve pages.

This is an encapsulated assembly comprising a coil, integral magnetic iron path and snap-on plug connection.

The synthetic material encapsulation provides an effective compact housing, offering full protection against dust, oil, water, etc.

Ease of mounting in confined space - offers shock and corrosion protection - simplifies conversion of existing equipment to other requirements, etc.

Coils conform to the IEC/CENELEC safety standards and complies with European low-voltage directive.



Specification		Standard			Double frequency		
Ref. (without DIN plug)		481865			483510		
Ref. (with DIN plug)		482725			482635		
Coil Group		2.0 / 2.1					
Degree of protection		IP65 according to IEC / EN 60529 standards (with DIN plug).					
Class of insulation		F 155°C					
Electrical connection		The coil is connected with a 2 P + E plug according to EN 175301-803 type A					
Ambient temperature		-40°C to +50°C The application is limited also by the temperature range of the valve.					
Elect. Power	DC	Pn (hot)	9 W		-		
		P (cold) 20°C	12 W		-		
	AC	Pn (holding)	8 W		9 W		
		Attraction cold	26 VA (9 W)		32 VA (10 W)		
Weight		130 g (without plug)					
Voltages "Un"		VAC/Hz	Code	VDC	Code	VAC/Hz	Code
-10% to +10% of the Un		24/50	A2	24	C2	24/50, 24/60	P0
		48/50	A4	48	C4	48/50, 48/60	S4
		110/50	A5	110	C5	110-115/50, 120/60	S5
		220-230/50	3D			220-240/50, 240/60	S6

To Order a Coil choose Coil Ref + Voltage Code, example: 481865 for 24 VDC = 481865C2

More voltage possibilities can be found in the table of voltage codes at the end of the coil section.

These coils must be used with suitable housings, see example below:

The coil assembly kit Ref. 2995 corresponds to the "housing" of Lucifer® valve numbering system (Valve - housing - coil/voltage).

It is composed of a nameplate giving details of the valve type, a round washer and a nut to ensure the fixing between 32 mm coil and the valve.

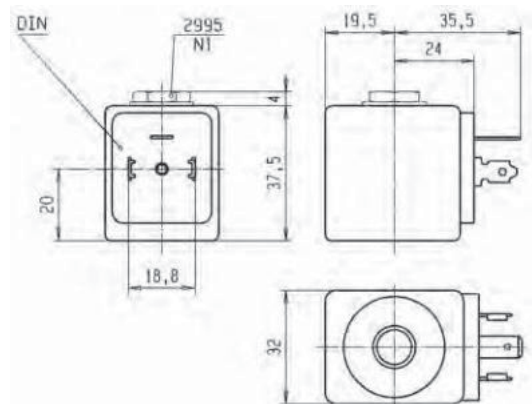

COIL GROUP
2.0/2.1
2.2

COILS FOR
 DIN PLUG CONNECTION



HIGH TEMPERATURE COILS 32 mm

These coils can be mounted with every Parker solenoid valves corresponding to the specified Coil Group. See column "Coil Group" within valve pages.

This is an encapsulated assembly comprising a coil, integral magnetic iron path and snap-on plug connection.

The synthetic material encapsulation provides an effective compact housing, offering full protection against dust, oil, water, etc.

Ease of mounting in confined space - offers shock and corrosion protection - simplifies conversion of existing equipment to other requirements, etc.

Coils conform to the IEC/CENELEC safety standards and complies with European low-voltage directive.



Specification		High temperature				High temp. + high power				
Ref. (without DIN plug)		492453				492425				
Ref. (with DIN plug)		492726				492727				
Coil Group		2.0 / 2.1				2.0 / 2.2				
Degree of protection		IP65 according to IEC / EN 60529 standards (with DIN plug).								
Class of insulation		H 180°C								
Electrical connection		The coil is connected with a 2 P + E plug according to EN 175301-803 type A								
Ambient temperature		-40°C to +50°C The application is limited also by the temperature range of the valve.								
Elect. Power	DC	Pn (hot)	9 W				14 W			
		P (cold) 20°C	12 W				21 W			
	AC	Pn (holding)	8 W				14 W			
		Attraction cold	26 VA (9 W)				55 VA (18 W)			
Weight		130 g (without plug)								
Voltages "Un"		VAC/Hz	Code	VDC	Code	VAC/Hz	Code	VDC	Code	
-10% to +10% of the Un		24/50	A2	12	C1	24/50	A2	24	C2	
		48/50	A4	24	C2	110/50	A5			
		110/50	A5	48	C4	230/50	F4			
		220/50-230/50	3D	110	C5					

To Order a Coil choose Coil Ref + Voltage Code, example: 492453 for 24 VDC= **492453C2**
 More voltage possibilities can be found in the table of voltage codes at the end of the coil section.

These coils must be used with suitable housings, see example below:

The coil assembly kit **Ref. 2995** corresponds to the "housing" of Lucifer® valve numbering system (Valve - housing - coil/voltage).

It is composed of a nameplate giving details of the valve type, a round washer and a nut to ensure the fixing between 32 mm coil and the valve.

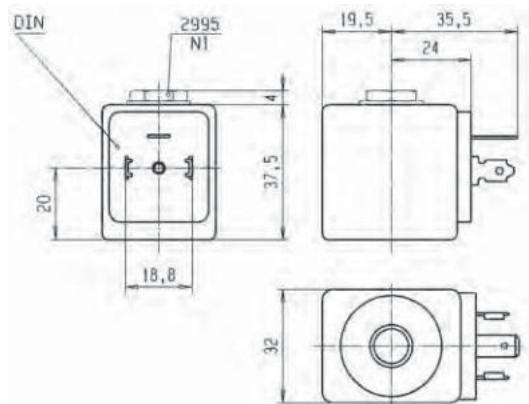



REDUCED POWER COIL 32 mm

These coils can be mounted with every Parker solenoid valves corresponding to the specified Coil Group. See column "Coil Group" within valve pages.

This is an encapsulated assembly comprising a coil, integral magnetic iron path and snap-on plug connection.

The synthetic material encapsulation provides an effective compact housing, offering full protection against dust, oil, water, etc.

Ease of mounting in confined space - offers shock and corrosion protection - simplifies conversion of existing equipment to other requirements, etc.

Coils conform to the IEC/CENELEC safety standards and complies with European low-voltage directive.



Specification		Reduced power			
Ref. (without DIN plug)		482730			
Ref. (with DIN plug)		482735			
Coil Group		3.0			
Degree of protection		IP65 according to IEC / EN 60529 standards (with DIN plug).			
Class of insulation		F 155°C			
Electrical connection		The coil is connected with a 2 P + E plug according to EN 175301-803 type A			
Ambient temperature		-40°C to +50°C The application is limited also by the temperature range of the valve.			
Elect. Power	DC	Pn (hot)	7 W		
		P (cold) 20°C	9 W		
	AC	Pn (holding)	6 W		
		Attraction cold	20 VA (7 W)		
Weight		130 g (without plug)			
Voltages "Un"		VAC/Hz	Code	VDC	Code
-10% to +10% of the Un		48/50	A4	24	C2
		220-230/50	3D	48	C4

To Order a Coil choose Coil Ref + Voltage Code, example: 482730 for 24 VDC = **482730C2**
More voltage possibilities can be found in the table of voltage codes at the end of the coil section.

These coils must be used with suitable housings, see example below:

The coil assembly kit **Ref. 2995** corresponds to the "housing" of Lucifer® valve numbering system (Valve - housing - coil/voltage).

It is composed of a nameplate giving details of the valve type, a round washer and a nut to ensure the fixing between 32 mm coil and the valve.

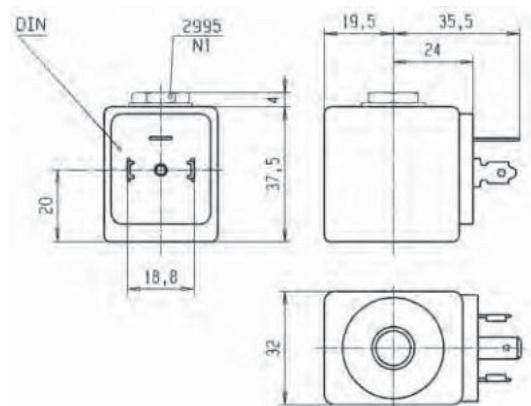

LOW POWER COIL 32 mm

These coils can be mounted with every Parker solenoid valves corresponding to the specified Coil Group. See column "Coil Group" within valve pages.

This is an encapsulated assembly comprising a coil, integral magnetic iron path and snap-on plug connection.

The synthetic material encapsulation provides an effective compact housing, offering full protection against dust, oil, water, etc.

Ease of mounting in confined space - offers shock and corrosion protection - simplifies conversion of existing equipment to other requirements, etc.

Coils conform to the IEC/CENELEC safety standards and complies with European low-voltage directive.



Specification		Miniwatt	
Reference (without DIN plug)		482740	
Reference (with DIN plug)		482745	
Coil Group		6.0	
Degree of protection		IP65 according to IEC / EN 60529 standards (with DIN plug).	
Class of insulation		F 155°C	
Electrical connection		The coil is connected with a 2 P + E plug according to EN 175301-803 type A	
Ambient temperature		-40°C to +50°C The application is limited also by the temperature range of the valve.	
Elect. Power	DC	Pn (hot)	1.6 W
		P (cold) 20°C	2.1 W
	AC	Pn (holding)	-
		Attraction cold	-
Weight		130 g (without plug)	
Voltages "Un"		VDC	Code
-10% to +10% of the Un		24	C2
		48	C4
		110	C5

To Order a Coil choose Coil Ref + Voltage Code, example: 482740 for 24 VDC = **482740C2**

More voltage possibilities can be found in the table of voltage codes at the end of the coil section.

These coils must be used with suitable housings, see example below:

The coil assembly kit **Ref. 2995** corresponds to the "housing" of Lucifer® valve numbering system (Valve - housing - coil/voltage).

It is composed of a nameplate giving details of the valve type, a round washer and a nut to ensure the fixing between 32 mm coil and the valve.

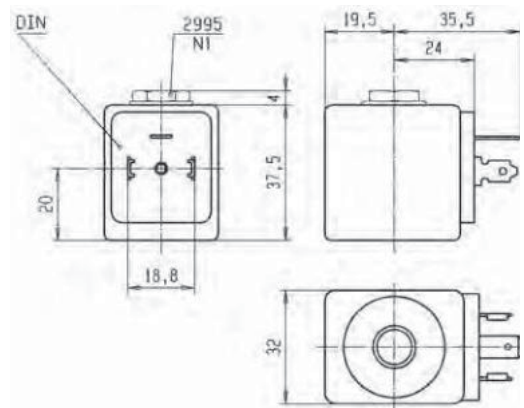



UL COIL 32 mm

This coil can be mounted with every Parker solenoid valves corresponding to the specified Coil Group. See column "Coil Group" within valve pages.

This is an encapsulated assembly comprising a coil, integral magnetic iron path and snap-on plug connection.

The synthetic material encapsulation provides an effective compact housing, offering full protection against dust, oil, water, etc.

Ease of mounting in confined space - offers shock and corrosion protection - simplifies conversion of existing equipment to other requirements, etc. Coils conform to the IEC/CENELEC safety standards and complies with European low-voltage directive.

DIN plug connector to be ordered separately (see coil accessories section)



Specification		UL-recognized coil - UL File E200N - designation AMIF			
Reference (without DIN plug)		491514			
Coil Group		2.0 / 2.1			
Degree of protection		IP65 according to IEC / EN 60529 standards (with DIN plug).			
Class of insulation		F (155°C)			
Electrical connection		The coil is connected with a 2 P + E plug according to EN 175301-803 type A			
Ambient temperature		-40°C to 50°C The application is limited also by the temperature range of the valve.			
Elect. Power	DC	Pn (hot)	-	12 W	
		P (cold) 20°C	-	16 W	
	AC	Pn (holding)	11 W	-	
		Attraction cold	40 VA (13 W)	-	
Weight		130 g (without plug)			
Voltages "Un"		VAC/Hz	Code	VDC	Code
- 15% to +10% of the Un		110/50-120/60 220/50-240/60	P3 Q3	24	C2

To Order a Coil choose Coil Ref + Voltage Code, example: 491514 for 24 VDC = 491514C2
More voltage possibilities can be found in the table of voltage codes at the end of the coil section.

These coils must be used with suitable housings, see example below:

The coil assembly kit Ref. 2995 with non UL valve and Ref. 2995.03 with UL valve correspond to the "housing" of Lucifer® valve numbering system (Valve - housing - coil/voltage).

It is composed of a nameplate giving details of the valve type, a round washer and a nut to ensure the fixing between 32 mm coil and the valve.

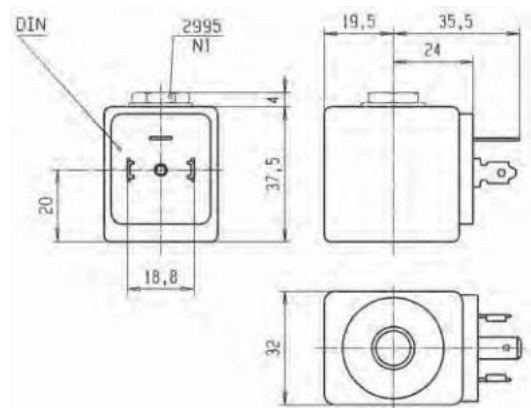



UL COIL 32 mm

This coil can be mounted with every Parker solenoid valves corresponding to the specified Coil Group. See column "Coil Group" within valve pages.

This is an encapsulated assembly comprising a coil, integral magnetic iron path and snap-on plug connection.

The synthetic material encapsulation provides an effective compact housing, offering full protection against dust, oil, water, etc.

Ease of mounting in confined space - offers shock and corrosion protection - simplifies conversion of existing equipment to other requirements, etc.

Coils conform to the IEC/CENELEC safety standards and complies with European low-voltage directive.



Specification		Coil for oil burner - UL recognized	
Reference (without DIN plug)		483764	
Coil group		14.2	
Degree of protection		IP65 according to IEC / EN 60529 standards (with DIN plug).	
Class of insulation		F 155°C	
Electrical connection		With DIN 43650 A Plug	
Ambient temperature		-40°C to 50°C The application is limited also by the temperature range of the valve.	
Elect. Power	DC	Pn (hot)	-
		P (cold) 20°C	-
	AC	Pn (holding)	9 W
		Attraction cold	-
Weight		138 g	
Voltages "Un"		VAC/Hz	Code
- 15% to +10% of the Un		240/50-60	Q1
		110/50-115/60	Q9
		230/50-240/60	T1

To Order a Coil choose Coil Ref + Voltage Code, example: 483764 for 240/50-60 = **483764Q1**

More voltage possibilities can be found in the table of voltage codes at the end of the coil section.

These coils must be used with suitable housings, see example below:

The coil assembly kit **Ref. 2995** corresponds to the "housing" of Lucifer® valve numbering system (Valve - housing - coil - voltage).

It is composed of a nameplate giving details of the valve type, a round washer and a nut to ensure the fixing between 32 mm coil and the valve.

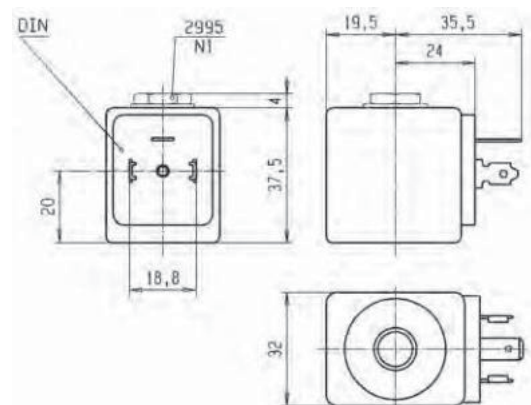

2.2

COILS FOR
DIN PLUG CONNECTION



COIL 32 mm FOR JET VALVES

This coil can be mounted with every Parker solenoid valves corresponding to the specified Coil Group. See column "Coil Group" within valve pages.

This is an encapsulated assembly comprising a coil, integral magnetic iron path and snap-on plug connection.

The synthetic material encapsulation provides an effective compact housing, offering full protection against dust, oil, water, etc.

Ease of mounting in confined space - offers shock and corrosion protection - simplifies conversion of existing equipment to other requirements, etc.

Coils conform to the IEC/CENELEC safety standards and complies with European low-voltage directive.

DIN plug connector to be ordered separately (see coil accessories section)



Specification		32 mm coil 14 W			
Reference		483816			
Coil Group		2.2			
Degree of protection		IP65 according to IEC / EN 60529 standards (with DIN plug).			
Class of insulation		F 155°C			
Electrical connection		The coil is connected with a 2 P + E plug according to EN 175301-803 type A			
Ambient temperature		-40°C to +50°C The application is limited also by the temperature range of the valve.			
Elect. Power	DC	Pn (hot)	14 W		
		P (cold) 20°C	-		
	AC	Pn (holding)	14 W		
		Attraction cold	-		
Weight		160 g			
Voltages "Un"		VAC/Hz	Code	VDC	Code
-10% to +10% of the Un		24/50	A2	24 V	C2

To Order a Coil choose Coil Ref + Voltage Code, example: 483816 for 24 VDC = 483816C2

More voltage possibilities can be found in the table of voltage codes at the end of the coil section.

These coils must be used with suitable housings, see example below:

The coil assembly kit Ref. 2995 corresponds to the "housing" of Lucifer® valve numbering system (Valve - housing - coil/voltage).

It is composed of a nameplate giving details of the valve type, a round washer and a nut to ensure the fixing between 32 mm coil and the valve.

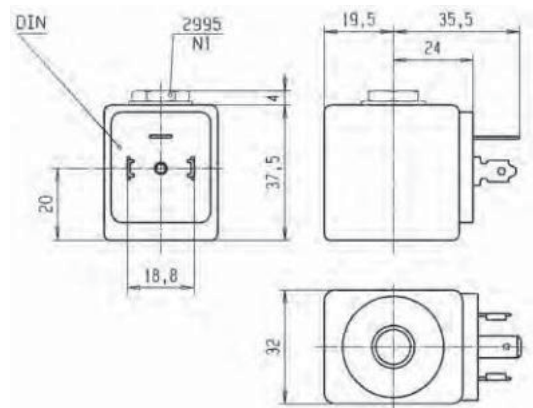

1.1

COILS FOR DIN PLUG CONNECTION



COILS 22 mm

These coils can be mounted with every Parker solenoid valves corresponding to the specified Coil Group. See column "Coil Group" within valve pages.

This coil is designed for valves equipped with a miniature tube assembly (2000 series valves). This is an encapsulated assembly comprising a coil, integral magnetic iron path and snap-on plug connection.

The synthetic material encapsulation provides an effective compact housing, offering full protection against dust, oil, water, etc. Ease of mounting in confined space - offers shock and corrosion protection - simplifies conversion of existing equipment to other requirements, etc. Coil conforms to the IEC/CENELEC safety standards and complies with European low-voltage directive.



Specification		Low power			High power				
Ref. (without DIN plug)		488980			481180				
Ref. (with DIN plug)		481045			481530				
Coil Group		1.1							
Degree of protection		IP65 according to IEC / EN 60529 standards (with DIN plug).							
Class of insulation		F 155°C							
Electrical connection		The coil is connected with a 2 P + E plug according to EN 175301-803 type B.							
Ambient temperature		-40°C to +50°C The application is limited also by the temperature range of the valve.							
Elect. Power	DC	Pn (hot)	2.5 W			5 W			
		P (cold) 20°C	3 W			6.5 W			
	AC	Pn (holding)	2 W			4 W			
		Attraction cold	5.7 VA (2.5 W)			8.9 VA (5 W)			
Weight		100 g with DIN Plug							
Voltages "Un"		VAC/Hz	Code	VDC	Code	VAC/Hz	Code	VDC	Code
-10% to +10% of the Un		24/50	A2	24	C2	24/50	A2	24	C2
		48/50	A4						
		110/50-115/50	0A	110	C5	220/50-230/50	3D		
		220/50-230/50	3D						

To Order a Coil choose Coil Ref + Voltage Code, example: 488980 for 24 VDC = 488980C2
More voltage possibilities can be found in the table of voltage codes at the end of the coil section.

These coils must be used with suitable housings, see example below:

The coil assembly kit Ref. 8993 corresponds to the numbering system for Lucifer® valve housings (Valve - housing - coil/voltage).

It is composed of a nameplate with the details of the valve type, a washer and a nut to secure the 22 mm coil to the valve.

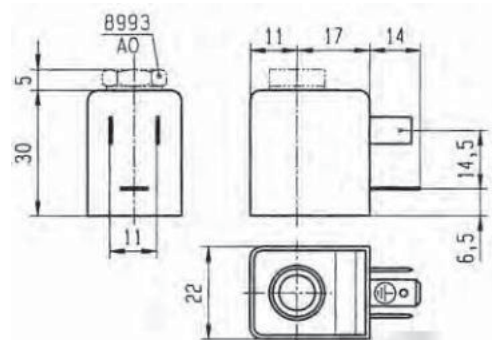



UL COIL 22 mm

These coils can be mounted with every Parker solenoid valves corresponding to the specified Coil Group. See column "Coil Group" within valve pages.

This coil is designed for valves equipped with a miniature tube assembly (2000 series valves). This is an encapsulated assembly comprising a coil, integral magnetic iron path and snap-on plug connection.

The synthetic material encapsulation provides an effective compact housing, offering full protection against dust, oil, water, etc. Ease of mounting in confined space - offers shock and corrosion protection - simplifies conversion of existing equipment to other requirements, etc. Coil conforms to the IEC/CENELEC safety standards and complies with European low-voltage directive.



Specification		Standard UL (only if used with 321K, 121M, 131M valves)			
Reference (without DIN plug)		492912			
Reference (with DIN plug)		492919			
Coil Group		1.1			
Degree of protection		IP65 according to IEC / EN 60529 standards (with DIN plug).			
Class of insulation		A 105°C for UL/CSA			
Electrical connection		The coil is connected with a 2 P + E plug according to EN 175301-803 type B.			
Ambient temperature		-40°C to +50°C The application is limited also by the temperature range of the valve.			
Elect. Power	DC	Pn (hot)	4 W		
		P (cold) 20°C	4,5 W		
	AC	Pn (holding)	3 W		
		Attraction cold	7.5 VA (4 W)		
Weight		100 g with DIN Plug			
Voltages "Un"		VAC/Hz	Code	VDC	Code
- 15% to +10% of the Un		48/50-48/60	S4	24	C2
		115/50-120/60	P8		

To Order a Coil choose Coil Ref + Voltage Code, example: 492912 for 24 VDC = **492912C2**
More voltage possibilities can be found in the table of voltage codes at the end of the coil section.

These coils must be used with suitable housings, see example below:

The coil assembly kit **Ref. 8993** corresponds to the "housing" of Lucifer® valve numbering system (Valve - housing - coil/voltage).

It is composed of a nameplate giving details of the valve type, a round washer and a nut to ensure the fixing between 22 mm coil and the valve.

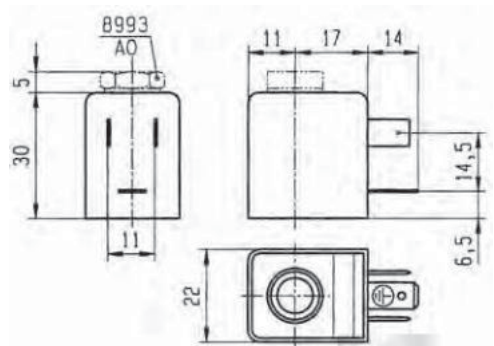



DOUBLE FREQUENCY COIL 22 mm

This coil can be mounted with every Parker solenoid valves corresponding to the specified Coil Group. See column "Coil Group" within valve pages.

This coil is designed for valves equipped with a miniature tube assembly (2000 series valves). This is an encapsulated assembly comprising a coil, integral magnetic iron path and snap-on plug connection.

The synthetic material encapsulation provides an effective compact housing, offering full protection against dust, oil, water, etc. Ease of mounting in confined space - offers shock and corrosion protection - simplifies conversion of existing equipment to other requirements, etc. Coil conforms to the IEC/CENELEC safety standards and complies with European low-voltage directive.

DIN plug connector to be ordered separately (see coil accessories section).



Specification		Double frequency	
Reference (without DIN plug)		483590	
Coil group		1.1	
Degree of protection		IP65 according to IEC / EN 60529 standards (with DIN plug).	
Class of insulation		F 155°C	
Electrical connection		The coil is connected with a 2 P + E plug according to EN 175301-803 type B.	
Ambient temperature		-40°C to +50°C The application is limited also by the temperature range of the valve.	
Elect. Power	DC	Pn (hot)	-
		P (cold) 20°C	-
	AC	Pn (holding)	3 W
		Attraction cold	7.5 VA (4 W)
Weight		100 g with DIN Plug	
Voltages "Un"		VAC/Hz	Code
-10% to +10% of the Un		24/50-60	P0
		48/50-60	S4
		110-115/50, 120/60	S5
		220-240/50, 240/60	S6

To Order a Coil choose Coil Ref + Voltage Code, example: 483590 for 24/50,24/60 = **483590P0**
More voltage possibilities can be found in the table of voltage codes at the end of the coil section.

These coils must be used with suitable housings, see example below:

The coil assembly kit **Ref. 8993** corresponds to the "housing" of Lucifer® valve numbering system (Valve - housing - coil/voltage).

It is composed of a nameplate giving details of the valve type, a round washer and a nut to ensure the fixing between 22 mm coil and the valve.

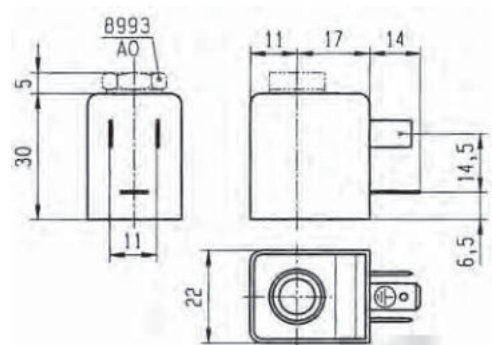



DOUBLE FREQUENCY COIL 22 mm

This coil can be mounted with every Parker solenoid valves corresponding to the specified Coil Group. See column "Coil Group" within valve pages.

This coil is designed for valves equipped with a miniature tube assembly (2000 series valves). This is an encapsulated assembly comprising a coil, integral magnetic iron path and snap-on plug connection.

The synthetic material encapsulation provides an effective compact housing, offering full protection against dust, oil, water, etc.

Ease of mounting in confined space - offers shock and corrosion protection - simplifies conversion of existing equipment to other requirements, etc.

Coil conforms to the IEC/CENELEC safety standards and complies with European low-voltage directive.

DIN plug connector to be ordered separately (see coil accessories section).



Specification		Double frequency	
Reference (without DIN Plug)		488143	
Coil group		1.1	
Degree of protection		IP65 according to IEC / EN 60529 standards (with DIN plug).	
Class of insulation		F 155°C	
Electrical connection		The coil is connected with a 2 P + E plug according to EN 175301-803 type B.	
Ambient temperature		-40°C to +50°C The application is limited also by the temperature range of the valve.	
Elect. Power	DC	Pn (hot)	-
		P (cold) 20°C	-
	AC	Pn (holding)	2.5 W
		Attraction cold	-
Weight		60 g	
Voltages "Un"		VAC/Hz	Code
-10% to +10% of the Un		100/50-60	P1
		200/50-60	P6

To Order a Coil choose Coil Ref + Voltage Code, example: 488143 for 100/50-60 = 488143P1

More voltage possibilities can be found in the table of voltage codes at the end of the coil section.

These coils must be used with suitable housings, see example below:

The coil assembly kit **Ref. 8993** corresponds to the "housing" of Lucifer® valve numbering system (Valve - housing - coil/voltage).

It is composed of a nameplate giving details of the valve type, a round washer and a nut to ensure the fixing between 22 mm coil and the valve.

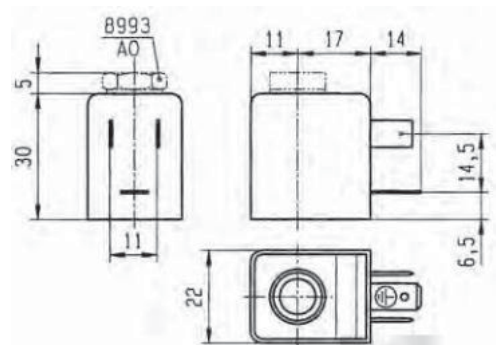



DOUBLE FREQUENCY COIL 22 mm

This coil can be mounted with every Parker solenoid valves corresponding to the specified Coil Group. See column "Coil Group" within valve pages.

This coil is designed for valves equipped with a miniature tube assembly (2000 series valves). This is an encapsulated assembly comprising a coil, integral magnetic iron path and snap-on plug connection.

The synthetic material encapsulation provides an effective compact housing, offering full protection against dust, oil, water, etc.

Ease of mounting in confined space - offers shock and corrosion protection - simplifies conversion of existing equipment to other requirements, etc.

Coil conforms to the IEC/CENELEC safety standards and complies with European low-voltage directive.

DIN plug connector to be ordered separately (see coil accessories section).



Specification		Double frequency			
Reference (without DIN Plug)		496131			
Coil group		1.2			
Degree of protection		IP65 according to IEC / EN 60529 standards (with DIN plug).			
Class of insulation		F 155°C			
Electrical connection		The coil is connected with a 2 P + E plug according to EN 175301-803 type B.			
Ambient temperature		-40°C to +50°C The application is limited also by the temperature range of the valve.			
Elect. Power	DC	Pn (hot)	3 W		
		P (cold) 20°C	-		
	AC	Pn (holding)	3 W		
		Attraction cold	-		
Weight		60 g			
Voltages "Un"		VAC/Hz	Code	VDC	Code
-10% to +10% of the Un		24/50-60	P0	24 V	C2
		110/50-60	P2	48 V	C4
		230/50-60	P9	110 V	C5
		48/50-60	S4		

To Order a Coil choose Coil Ref + Voltage Code, example: 496131 for 24 VDC = **496131C2**

More voltage possibilities can be found in the table of voltage codes at the end of the coil section.

"The housing kit is already included in the valve reference, it is not needed to order it separately."

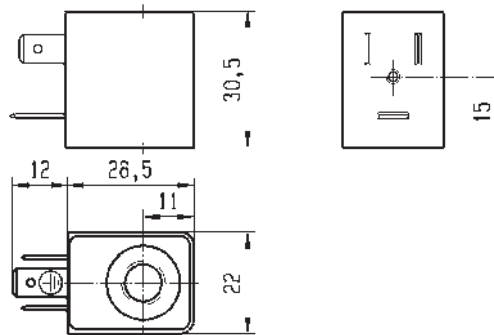



DOUBLE FREQUENCY COIL 22 mm

This coil can be mounted with every Parker solenoid valves corresponding to the specified Coil Group. See column "Coil Group" within valve pages.

This coil is designed for valves equipped with a miniature tube assembly (2000 series valves). This is an encapsulated assembly comprising a coil, integral magnetic iron path and snap-on plug connection.

The synthetic material encapsulation provides an effective compact housing, offering full protection against dust, oil, water, etc.

Ease of mounting in confined space - offers shock and corrosion protection - simplifies conversion of existing equipment to other requirements, etc.

Coil conforms to the IEC/CENELEC safety standards and complies with European low-voltage directive.

DIN plug connector included.



Specification		Double frequency			
Reference		496482			
Coil group		1.2			
Degree of protection		IP65 according to IEC / EN 60529 standards (with DIN plug).			
Class of insulation		F 155°C			
Electrical connection		The coil is connected with a 2 P + E plug according to EN 175301-803 type B.			
Ambient temperature		-40°C to +50°C The application is limited also by the temperature range of the valve.			
Elect. Power	DC	Pn (hot)	3 W		
		P (cold) 20°C	-		
	AC	Pn (holding)	3 W		
		Attraction cold	-		
Weight		75 g			
Voltages "Un"		VAC/Hz	Code	VDC	Code
-10% to +10% of the Un		24/50-60	P0	24 V	C2
		110/50-60	P2	48 V	C4
		230/50-60	P9	110 V	C5
		48/50-60	S4		

To Order a Coil choose Coil Ref + Voltage Code, example: 496482 for 24 VDC = **496482C2**
More voltage possibilities can be found in the table of voltage codes at the end of the coil section.

"The housing kit is already included in the valve reference, it is not needed to order it separately."

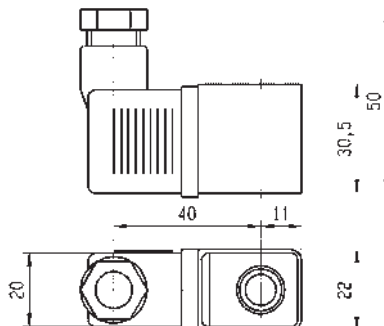

1.3

COILS FOR
DIN PLUG CONNECTION



WB COIL SERIES 22 mm

These coils can be mounted with every Parker solenoid valves corresponding to the specified Coil Group. See column "Coil Group" within valve pages.

These coils can be mounted with the majority of type 2 operators. Coil manufactured with H class copper wire, moulded in thermoplastic material polyester with 30% glass fiber. IP65 protection rate with DIN 43650A three pin connector and appropriate gasket.

The synthetic material encapsulation provides an effective compact housing, offering full protection against dust, oil, water, etc. Coils conforms to the IEC/CENELEC safety standards and complies with European low-voltage directive. For UL recognized version: UL file MH19410.

DIN plug connector to be ordered separately (see coil accessories section).



Specification		Standard		UL recognized version		High Power	
Ref. (without DIN plug)		WB4.5 for AC WB5.0 for DC		WB4.5 UR WB5.0 cURus (only 24 VDC)		WB8.0	
Coil Group				1.3			
Degree of protection		IP65 according to IEC / EN 60529 standards (with DIN plug + gasket)					
Class of insulation		F 155°C		F 155°C		F 155°C	
Electrical connection		The coil is connected with a 2 P + E plug according to EN 175301-803 type B.					
Ambient temperature		-10°C to +50°C		-10°C to +50°C		-10°C to +50°C	
		The application is limited also by the temperature range of the valve.					
Elect. Power	DC	P (cold) 20°C	5 W				
	AC	Pn (holding)	4.5 W	4.5 W		8 W	
		Attraction cold	7.5 VA	7.5 VA		11 VA	
Weight		90 g (without plug)					
Voltages "Un"		WB4.5 VAC/Hz	Order Number	WB4.5 UR VAC/Hz	Order Number	WB8.0 VAC/Hz	Order Number
-10% to +10% of Un for AC - 5 % to + 10 % for Un DC		100/50-60	302609	115/60	304087	115/50-60	302672
		115/50-60	304260	208-240/60	304089	230/50-60	302674
		230/50-60	304262J	24/60	304086	24/50-60	302670
		110/50	304316				
		WB5.0 VDC	Order Number	WB5.0 cURus VDC	Order Number		
		110 VDC	302660	24 VDC	302654		
		12 VDC	302652				

To Order a Coil: Use 6 digits ordering number - Code Example: WB8.0 for 115/50-60 = 302672
More voltage possibilities can be found in the table of voltage codes at the end of the coil section.

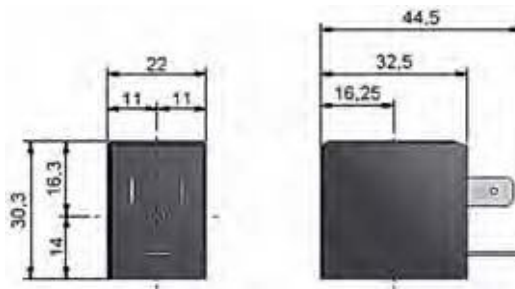



ZB COIL SERIES

These coils can be mounted with every Parker solenoid valves corresponding to the specified Coil Group. See column "Coil Group" within valve pages.

Coil manufactured with H class copper wire, moulded in thermoplastic material polyester with 30% glass fiber. IP65 protection rate with EN 175301-803:2006-A. Three pin connector.

This coil conforms to the IEC/CENELEC safety standards and complies with European low-voltage directive.

For UL recognized version: UL file MH19410.

DIN plug connector to be ordered separately (see coil accessories section).



Specification		Standard			UL recognized version		
Reference (without DIN plug)		ZB09/ZB12			ZB09 for AC only		
Coil Group		20.1					
Degree of protection		IP65 according to IEC / EN 60529 standards (with DIN plug and gasket)					
Class of insulation		F 155°C					
Electrical connection		The coil is connected with a 2 P + E plug according to EN 175301-803 - type A					
Ambient temperature		-10°C to +50°C The application is limited also by the temperature range of the valve.					
Elect. Power	DC	P (cold) 20°C			12 W		
	AC	P (cold) 20°C			9 W		
		Attraction cold			25 VA		
Weight					130 g		
Voltages "Un"		VAC/Hz	Order Number	VDC	Order Number	VAC/Hz	Order Number
-10% to +10% of Un for AC - 5 % to + 10 % for Un DC.		ZB09 24/50-60	304004	ZB12 12DC	304018	ZB09 24/60	304048
		ZB09 12/50-60	304002	ZB12 24DC	304020	ZB09 110-120/60	304011
		ZB09 230/50-60	304012	ZB12 110DC	304022	ZB09 208-240/60	304051
		ZB09 115/50-60	304010	ZB12 48VDC	304021		
		ZB09 100/50-60	304009				
		ZB09 240/50-60	304014				
		ZB09 48/50-60	304008				
		ZB09 110-120/60	304011				
ZB09 380/50-60	304016						

To Order a Coil: Use 6 digits ordering number - Code Example: ZB09 24/50-60 = 304004

More voltage possibilities can be found in the table of voltage codes at the end of the coil section.

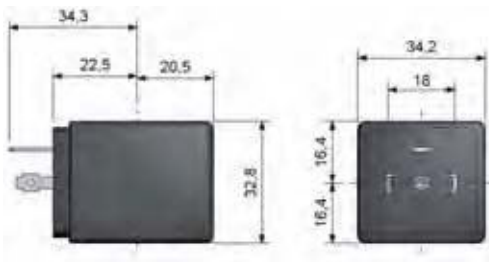



ZB/ZH HIGH POWER - HIGH TEMPERATURE COIL SERIES

These coils can be mounted with every Parker solenoid valves corresponding to the specified Coil Group.
See column "Coil Group" within valve pages.

Coil manufactured with H class copper wire, moulded in thermoplastic material polyester with 30% glass fiber.
IP65 protection rate with EN 175301-803:2006-A. Three pin connector.

This coil conforms to the IEC/CENELEC safety standards and complies with European low-voltage directive.

DIN plug connector to be ordered separately (see coil accessories section).



Specification		High power			High temperature + high power				
Ref. (without DIN plug)		ZB14/ZB16			ZH14/ZH16				
Coil Group		20.2							
Degree of protection		IP65 according to IEC / EN 60529 standards (with DIN plug and gasket)							
Class of insulation		H 180°C							
Electrical connection		The coil is connected with a 2 P + E plug according to EN 175301-803 - type A							
Ambient temperature		ZB14/ZB16 -10°C to +50°C			ZH14/ZH16 -10°C to +80°C				
		The application is limited also by the temperature range of the valve.							
Elect. Power	DC	P (cold) 20°C			16 W				
	AC	P (cold) 20°C			14 W				
		Attraction cold			33 VA				
Weight		130 g (without plug)							
Voltages "Un"		VAC/Hz	Order Number	VDC	Order Number	VAC/Hz	Order Number	VDC	Order Number
-10% to +10% of Un for AC - 5 % to + 10 % for Un DC		ZB14 12/50-60	304052	ZB16 12DC	304068	ZH14 24/50-60	304100	ZH16 24DC	304112
		ZB14 24/50-60	304054	ZB16 24DC	304070	ZH14 115/50-60	304102	ZH16 12DC	304110
		ZB14 100/50-60	304084	ZB16 110DC	304072	ZH14 230/50-60	304104		
		ZB14 115/50-60	304060						
		ZB14 230/50-60	304062						
		ZB14 240/50-60	304064						
		ZB14 380/50-60	304066						
		ZB14 48/50-60	304058						

To Order a Coil: Use 6 digits ordering number - Code Example: ZH16 for 24 VDC = 304112

More voltage possibilities can be found in the table of voltage codes at the end of the coil section.

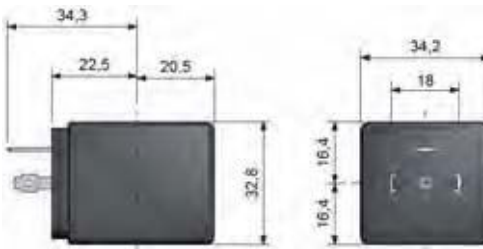



JB COIL SERIES

These coils can be mounted with every Parker solenoid valves corresponding to the specified Coil Group.
See column "Coil Group" within valve pages.

Coil manufactured with H class copper wire, moulded in thermoplastic material polyester with 30% glass fiber.
IP65 protection rate with EN 175301-803:2006-A. Three pin connector.

This coil conforms to the IEC/CENELEC safety standards and complies with European low-voltage directive.

DIN plug connector to be ordered separately (see coil accessories section).



Specification		Standard			
Ref. (without DIN plug)		JB14/JB16			
Coil Group		21.0			
Degree of protection		IP65 according to IEC / EN 60529 standards (with DIN plug and gasket)			
Class of insulation		F 155°C			
Electrical connection		The coil is connected with a 2 P + E plug according to EN 175301-803 - Type A			
Ambient temperature		-10°C to +50°C The application is limited also by the temperature range of the valve.			
Elect. Power	DC	P (cold) 20°C	16 W		
	AC	P (cold) 20°C	14 W		
		Attraction cold	55 VA		
Weight		130 g (without plug)			
Voltages "Un"		VAC/Hz	Order Number	VDC	Order Number
-10% to +10% of Un for AC - 5 % to + 10 % for Un DC.		JB14 24/50-60	304900	JB16 12DC	304945
		JB14 115/50-60	304910	JB16 24DC	304950
		JB14 230/50-60	304915	JB16 196DC	304958
		JB14 240/50-60	304920		

To Order a Coil: Use 6 digits ordering number - **Code Example:** JB16 for 12 VDC = 304945
More voltage possibilities can be found in the table of voltage codes at the end of the coil section.

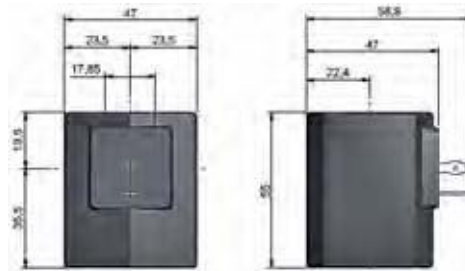



KT/KH COIL SERIES

These coils can be mounted with every Parker solenoid valves corresponding to the specified Coil Group. See column "Coil Group" within valve pages.

Coil manufactured with H class copper wire, moulded in thermoplastic material polyester with 30% glass fiber. IP65 protection rate with EN 175301-803:2006-A. Three pin connector.

This coil conforms to the IEC/CENELEC safety standards and complies with European low-voltage directive.

DIN plug connector to be ordered separately (see coil accessories section).



Specification			Standard			High Temperature		
Ref. (without DIN plug)			KT09/KT10			KH09		
Coil Group			22.0					
Degree of protection			IP65 according to IEC / EN 60529 standards (with DIN plug and gasket)					
Class of insulation			F 155°C			H 180°C		
Electrical connection			The coil is connected with a 2 P + E plug according to EN 175301-803 - Type A					
Ambient temperature			-10°C to +50°C			-10°C to +80°C		
			The application is limited also by the temperature range of the valve.					
Elect. Power	DC	P (cold) 20°C	10 W			-		
	AC	P (cold) 20°C	9 W			9 W		
		Attraction cold	20 VA			20 VA		
Weight			150 g (without plug)					
Voltages "Un"		VAC/Hz	Order Number	VDC	Order Number	VAC/Hz	Order Number	
-10% to +10% of Un for AC - 5 % to + 10 % for Un DC		KT09 24/50	304621	KT10 12DC	304666	KH09 24/50	304746	
		KT09 115/50	304631		KT10 24DC			
		KT09 208-230/60	304656					
		KT09-230/50	304639					
		KT09 240/50	304641					

To Order a Coil: Use 6 digits ordering number - Code Example: KT10 for 12VDC = 304666
More voltage possibilities can be found in the table of voltage codes at the end of the coil section.

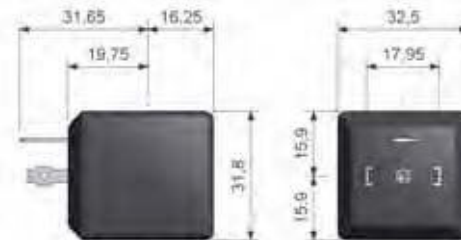

XT09 COIL SERIES

This coil can be mounted with every Parker solenoid valves corresponding to the specified Coil Group. See column "Coil Group" within valve pages.

Coil manufactured with H class copper wire, moulded in thermoplastic material polyester with 30% glass fiber. IP54 protection rate with special 2P+E connection. Special plug with integrated powercord available separately.

This coil conforms to the IEC/CENELEC safety standards and complies with European low-voltage directive.

DIN plug connector to be ordered separately (see coil accessories section).



Specification		For Heating Applications	
Ref. (without DIN plug)		XT09	
Coil Group		23.0	
Degree of protection		IP54 according to IEC / EN 60529 standards (with special plug supplied separately)	
Class of insulation		F 155°C	
Electrical connection		Special 2 P + E plug connection	
Ambient temperature		-10°C to +50°C The application is limited also by the temperature range of the valve.	
Elect. Power	DC	P (cold) 20°C	-
	AC	P (cold) 20°C	9 W
		Attraction cold	22 VA
Weight		150 g (without plug)	
Voltages "Un"		VAC/Hz	Order Number
-10% to +10% of Un for AC		XT09 230/50	304776

To Order a Coil: Use 6 digits ordering number - Code Example: XT09 230/50 = 304776

More voltage possibilities can be found in the table of voltage codes at the end of the coil section.

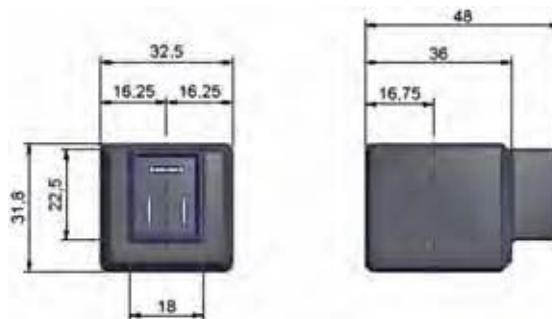



D4 SERIES - UL COILS 32 mm

This coil is UL-approved as a recognized component for the insulation Class 155, conforms to the IEC/CENELEC safety standards and complies with European low-voltage directive.

DIN plug connector to be ordered separately (see coil accessories section).



Specification		UL Recognized			
Reference (without DIN plug)		D4 Series			
Coil group		24.0			
Degree of protection		IP65 according to IEC / EN 60529 standards (with DIN plug)			
Class of insulation		F 155°C			
Electrical Connection		The coil is connected with a 2 P + E plug according to EN 175301-803 type A			
Ambient temperature		-40°C to +50°C The application is limited also by the temperature range of the valve.			
Elect. Power	DC	Pn (hot)	12 W		
		P (cold) 20°C	16 W		
	AC	Pn (holding)	11 W		
		Attraction cold	13VA		
Weight		130 g			
Voltages "Un"		VAC/Hz	Code	VDC	Code
-10% to +10% of Un for AC - 5 % to + 10 % for Un DC.		24/60	D4E	24	D4B
		110/50 - 120/60	D4F		
		220/50 - 240/60	D4G		

To Order a Coil: Use 6 digits ordering number - **Code Example:** D4 for 24VAC/60Hz = **D4E**

More voltage possibilities can be found in the table of voltage codes at the end of the coil section.

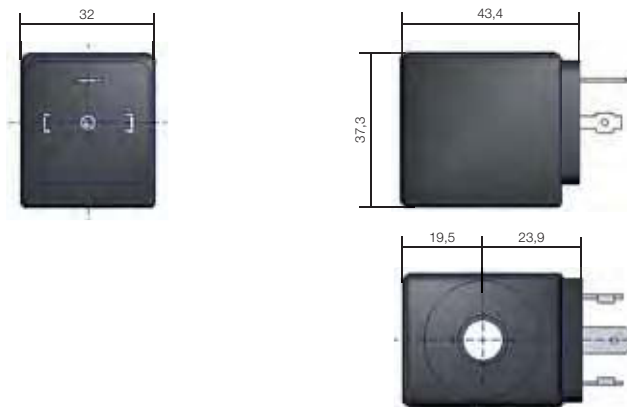



D5 COIL SERIES 32 mm

Encapsulated in synthetic material, Connector for 2P+E according with DIN EN 175301-803, Form A, IP65 degree of protection to be considered with connector plug only.

This coil conforms to the IEC/CENELEC safety standards and complies with European low-voltage directive.

DIN plug connector to be ordered separately (see coil accessories section).



Specification		Mono Frequency VDE Coil			
Reference (without DIN plug)		D5 Series			
Coil group		24.0			
Degree of protection		IP65 according to IEC / EN 60529 standards (with DIN plug)			
Class of insulation		F 155°C			
Electrical connection		The coil is connected with a 2 P + E plug according to EN 175301-803 type A.			
Ambient temperature		-40°C to +50°C The application is limited also by the temperature range of the valve.			
Elect. Power	DC	Pn (hot)	9 W		
		P (cold) 20°C	-		
	AC	P (cold) 20°C	8 W		
		Attraction cold	40 VA		
Weight		130 g			
Voltages "Un"		VAC/Hz	Code	VDC	Code
-10% to +10% of Un for AC - 5 % to + 10 % for Un DC.		24/50	D5H	24	D5B
		110/50	D5XA5		
		220-230/50	D5L		
		24/60	D5E		
		230/60	D5XJ3		
		115/60	D5XK8		

To Order a Coil: Use 6 digits ordering number - Code Example: D5 for 24 VAC/60 Hz = D5E
More voltage possibilities can be found in the table of voltage codes at the end of the coil section.

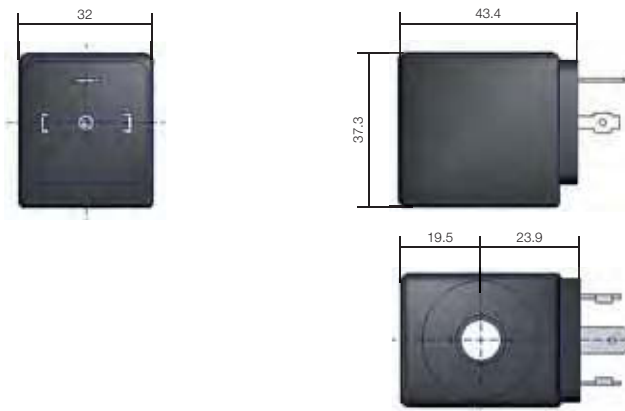



XS03 COIL SERIES 32 mm

Encapsulated in synthetic material, Connector for 2P+E according with DIN EN 175301-803, Form A, IP65 degree of protection to be considered with connector plug only.

This coil conforms to the IEC/CENELEC safety standards and complies with European low-voltage directive.

DIN plug connector to be ordered separately (see coil accessories section).



Specification		Bi- Frequency VDE Coil	
Reference (without DIN plug)		XS03 Series	
Coil group		24.0	
Degree of protection		IP65 according to IEC / EN 60529 standards (with DIN plug)	
Class of insulation		F 155°C	
Electrical Connection		The coil is connected with a 2 P + E plug according to EN 175301-803 type A	
Ambient temperature		-40°C to +50°C The application is limited also by the temperature range of the valve.	
Elect. Power	DC	Pn (hot)	-
		P (cold) 20°C	-
	AC	Pn (holding)	9 W
		Attraction cold	32 VA
Weight		130 g	
Voltages "Un"		VAC/Hz	Code
-10% to +10% of Un for AC		24/50 - 24/60	XS03M
		110-115/50 - 120/60	XS03XS5
		220-240/50 - 240/60	XS03XS6

To Order a Coil: Use 6 digits ordering number - **Code Example:** XS03 for 24/50-24/60 = **XS03M**

More voltage possibilities can be found in the table of voltage codes at the end of the coil section.

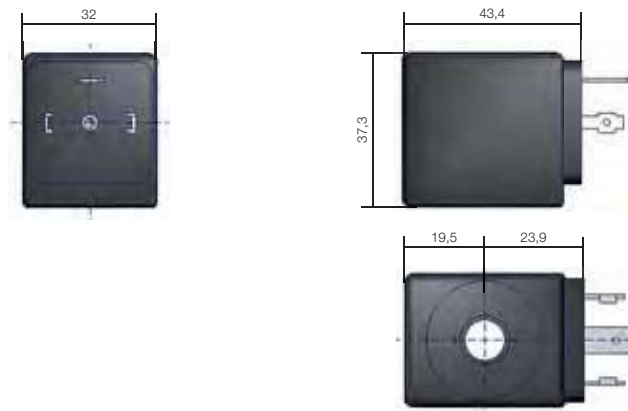

10.1

COILS FOR
DIN PLUG CONNECTION



COIL FOR OIL AND GAS 37 mm

This coil can be mounted with every Parker solenoid valves corresponding to the specified Coil Group.

See column "Coil Group" within valve pages.

This is an encapsulated assembly comprising a coil, integral magnetic iron path and snap-on plug connection.

The synthetic material encapsulation provides an effective compact housing, offering full protection against dust, oil, water, etc.

Ease of mounting in confined space - offers shock and corrosion protection - simplifies conversion of existing equipment to other requirements, etc.

Coils conform to the IEC/CENELEC safety standards and complies with European low-voltage directive. DIN plug connector included (The AC electrical connection is delivered with a rectifier bridge).



Specification		Coil for Oil and Gas			
Reference (with DIN plug)		496895			
Coil group		10.1			
Degree of protection		IP65 according to IEC / EN 60529 standards			
Class of insulation		H 180°C			
Electrical connection		With DIN plug 492459 (AC) or 486586 (DC)			
Ambient temperature		-40°C to +50°C The application is limited also by the temperature range of the valve.			
Elect. Power	DC	Pn (hot)	8 W		
		P (cold) 20°C	-		
	AC	Pn (holding)	8 W		
		Attraction cold	-		
Weight		273 g			
Voltages "Un"		VAC/Hz	Code	VDC	Code
-10% to +10% of the Un		230/50-60	P9	24	C2
		110/50-60	P2	48	C4
		24/50-60	P0	110	C5
		48/50-60	S4		

To Order a Coil choose Coil Ref + Voltage Code, example: 496895 for 24 VDC = 496895C2

More voltage possibilities can be found in the table of voltage codes at the end of the coil section.

The fixing nut (housing kit) is already included in the coil kit.

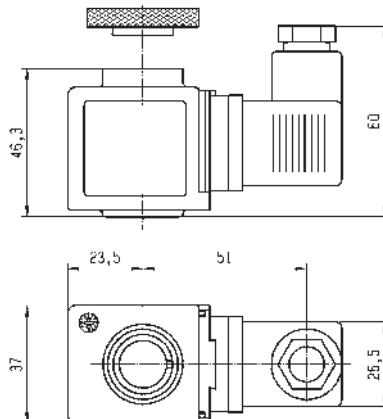

20.1

COILS WITH FLYING LEADS



YB COIL SERIES IP67

These coils can be mounted with every Parker solenoid valves corresponding to the specified Coil Group. See column "Coil Group" within valve pages.

Coil manufactured with H class copper wire, moulded in thermoplastic material polyester with 30% glass fiber. IP67 protection rate. Electrical connection: 2 x 1000 mm cables.

This coil conforms to the IEC/CENELEC safety standards and complies with European low-voltage directive.

For UL recognized version: UL file MH19410.



Specification		Standard			UL recognized version		
Reference		YB09/YB12			YB09		
Coil Group		20.1					
Degree of protection		IP67 according to IEC / EN 60529 standards					
Class of insulation		F 155°C					
Electrical connection		The coil is connected with a 2 x 1000 mm flying leads integrated.					
Ambient temperature		-10°C to +50°C The application is limited also by the temperature range of the valve.					
Elect. Power	DC	P (cold) 20°C	12 W		-		
	AC	Pn (holding)	9 W		9 W		
		Attraction cold	24 VA		24 VA		
Weight		150 g					
Voltages "Un"		VAC/Hz	Order Number	VDC	Order Number	VAC/Hz	Order Number
-10% to +10% of Un for AC - 5 % to + 10 % for Un DC.		YB09 115/50-60	304396	YB12 12DC	304412	YB09 24/60	304481
		YB09 230/50-60	304398	YB12 24DC	304416	YB09 110-120/60	304488
		YB09 24/50-60	304390			YB09 208-240/60	304483
		YB09 240/50-60	304400				

To Order a Coil: Use 6 digits ordering number - Code Example: YB09 for 24 VAC/60 Hz = 304481
More voltage possibilities can be found in the table of voltage codes at the end of the coil section.

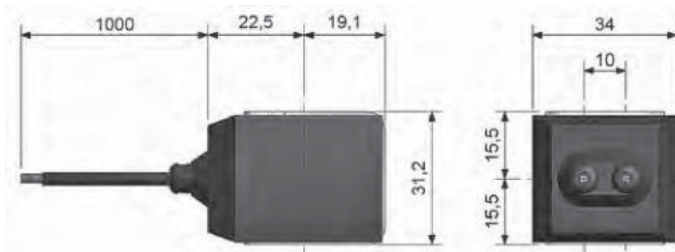



LA COIL SERIES 32 mm IP67

Encapsulated in synthetic material. Degree of protection IP67 as per IEC/EN60529.

Connection: 2 x 500 mm cables.

This coil conforms to the IEC/CENELEC safety standards and complies with European low-voltage directive.



Specification		Coil with two 500 mm flying leads			
Reference		LA Series			
Coil group		24.0			
Degree of protection		IP67 according to IEC / EN 60529 standards			
Class of insulation		F 155°C			
Ambient temperature		-10°C to +50°C The application is limited also by the temperature range of the valve.			
Elect. Power	DC	Pn (hot)	9 W		
		P (cold) 20°C	-		
	AC	Pn (holding)	9 W		
		Attraction cold	32 VA		
Weight		180 g			
Voltages "Un"		VAC/Hz	Code	VDC	Code
-10% to +10% of Un for AC - 5 % to + 10 % for Un DC.		24/50 - 24/60	LAM	24	LAB
		110-115/50 - 120/60	LAXS5		
		220-240/50 - 240/60	LAXS6		

To Order a Coil: Use 6 digits ordering number - **Code Example:** LA Series for 24 VDC = LAB
More voltage possibilities can be found in the table of voltage codes at the end of the coil section.

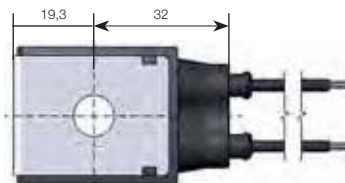
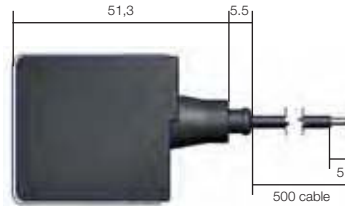
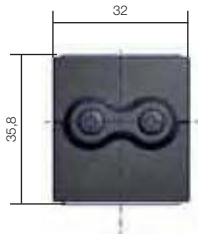



LB-LC COIL SERIES 32 mm UL IP67

Encapsulated in synthetic material. Degree of protection IP67 as per IEC/EN60529.

Connection: 2 x 500mm cables.

This coil is UL-approved as a recognized component for the insulation Class 155, conforms to the IEC/CENELEC safety standards and complies with European low-voltage directive.



Specification		UL Coil with two 500 mm flying leads			
Reference		LB-LC Series			
Coil group		24.0			
Degree of protection		IP67 according to IEC / EN 60529 standards			
Class of insulation		F 155°C			
Ambient temperature		-10°C to +50°C The application is limited also by the temperature range of the valve.			
Elect. Power	DC	Pn (hot)	16 W		
		P (cold) 20°C	-		
	AC	Pn (holding)	13-14 W		
		Attraction cold	40 VA		
Weight		180 g			
Voltages "Un"		VAC/Hz	Code	VDC	Code
-10% to +10% of Un for AC - 5 % to + 10 % for Un DC		24/60	LBE	24	LCB
		110/50 - 120/60	LBF		
		208-240/60	LBXU3		
		220/50 240/60	LBG		

To Order a Coil: Use 6 digits ordering number - **Code Example:** LB-LC for 24 VDC = LCB
More voltage possibilities can be found in the table of voltage codes at the end of the coil section.

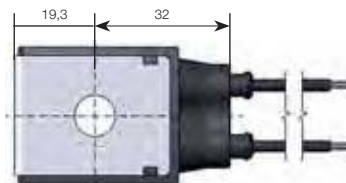
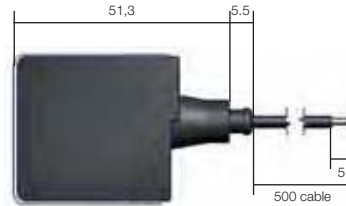
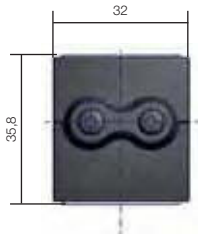



COIL 32 mm IP67

This coil can be mounted with every Parker solenoid valves corresponding to the specified Coil Group. See column "Coil Group" within valve pages.

This is an encapsulated assembly comprising a coil, integral magnetic iron path and snap-on plug connection.

The synthetic material encapsulation provides an effective compact housing, offering full protection against dust, oil, water, etc.

Ease of mounting in confined space - offers shock and corrosion protection - simplifies conversion of existing equipment to other requirements, etc.

Coils conform to the IEC/CENELEC safety standards and complies with European low-voltage directive.



Specification		Coil with two 500 mm flying leads			
Reference		496081			
Coil Group		2.0 / 2.1			
Degree of protection		IP67 according to IEC / EN 60529 standards			
Class of insulation		F 155°C			
Ambient temperature		-40 °C to +50°C The application is limited also by the temperature range of the valve.			
Elect. Power	DC	Pn (hot)	9 W		
		P (cold) 20°C	-		
	AC	Pn (holding)	9 W		
		Attraction cold	32 VA		
Weight		180 g			
Voltages "Un"		VAC/Hz	Order Number	VDC	Order Number
-10% to +10% of Un for AC		24/50 - 24/60	439816	24	439818
- 5 % to + 10 % for Un DC		110-115/50 - 120/60	439820	12	439814
		220-240/50 - 240/60	439822		

To Order a Coil: Use 6 digits ordering number - Code Example: 496081 for 24 VDC = 439818
More voltage possibilities can be found in the table of voltage codes at the end of the coil section.

For Parker Lucifer® valves please order housing Ref: 2995

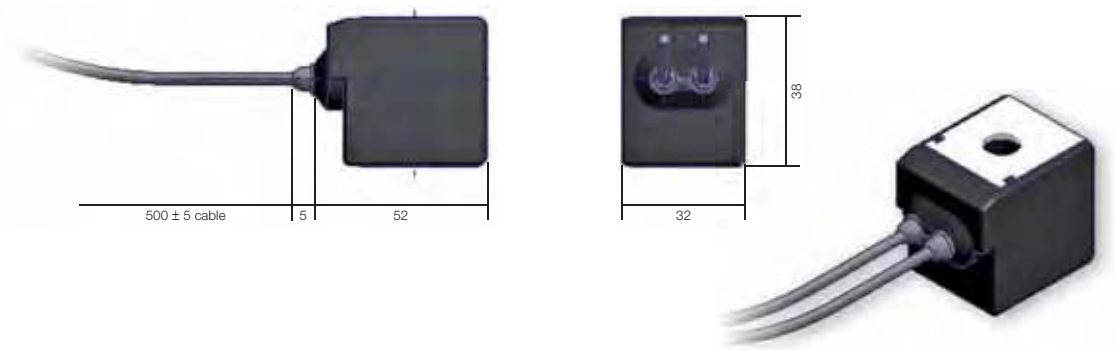



COIL 32 mm IP67 UL

This coil can be mounted with every Parker solenoid valves corresponding to the specified Coil Group. See column "Coil Group" within valve pages.

This is an encapsulated assembly comprising a coil, integral magnetic iron path and snap-on plug connection.

The synthetic material encapsulation provides an effective compact housing, offering full protection against dust, oil, water, etc.

Ease of mounting in confined space - offers shock and corrosion protection - simplifies conversion of existing equipment to other requirements, etc.

Coils conform to the IEC/CENELEC safety standards and complies with European low-voltage directive.



Specification		UL Coil with two 500 mm flying leads			
Reference		496082			
Coil Group		2.0 / 2.2			
Degree of protection		IP67 according to IEC / EN 60529 standards			
Class of insulation		F 155°C			
Ambient temperature		-40°C to +50°C The application is limited also by the temperature range of the valve.			
Elect. Power	DC	Pn (hot)	16 W		
		P (cold) 20°C	-		
	AC	Pn (holding)	13-14 W		
		Attraction cold	40 VA		
Weight		180 g			
Voltages "Un"		VAC/Hz	Order Number	VDC	Order Number
-10% to +10% of Un for AC - 5 % to + 10 % for Un DC		24/60	439826	24	439832
		110/50 - 120/60	439828		
		208-240/60	439824	12	439830
		220/50 - 240/60	439834		

To Order a Coil: Use 6 digits ordering number - Code Example: 496082 for 24 VDC= 439832
More voltage possibilities can be found in the table of voltage codes at the end of the coil section.

For Parker Lucifer® valves please order housing Ref: 2995

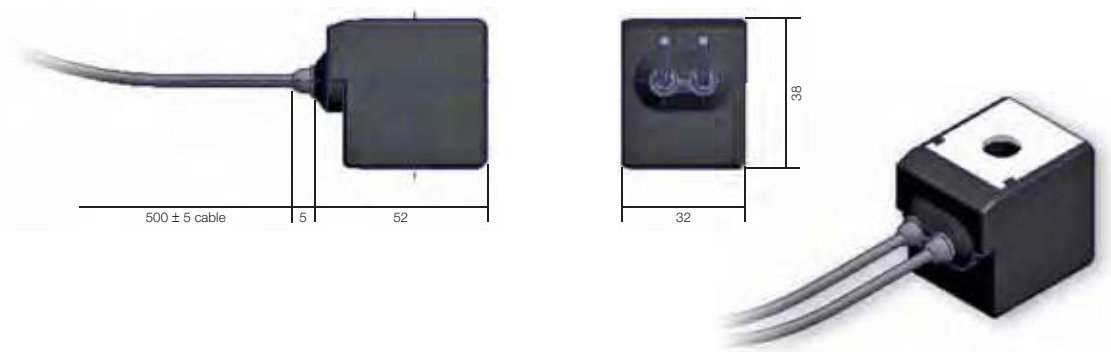



STANDARD COILS 40 mm

These coils can be mounted with every Parker Solenoid Valves corresponding to the specified Coil Group. See column "Coil Group" within valve pages.

They can be mounted with all metal housings.

The coil winding is completely encapsulated in synthetic material.

Easy mounting in confined spaces. Electrical connection with screw terminals for wire up to 1.5 mm².

Coils conform to the IEC/CENELEC safety standards and complies with European low-voltage directive.



Specification		Standard			Double Frequency		
Reference		481000			483520		
Coil Group		2.0 / 2.1					
Class of insulation		F 155°C					
Ambient temperature		-40°C to +50°C The application is limited also by the temperature range of the valve..					
Elect. Power	DC	Pn (hot)	8W		-		
		P (cold) 20°C	9W		-		
	AC	Pn (holding)	8W		9W		
		Attraction cold	32 VA (9 W)		36 VA (10 W)		
Weight		130 g			130 g		
Voltages "Un"		VAC/Hz	Code	VDC	Code	VAC/Hz	Code
-10% to +10% of the Un (-15 % to +5 % for double-frequency coil with voltage code S6 if 240 V/50/Hz is used).		24/50	A2	24	C2	24/50-60	P0
		48/50	A4	48	C4	220-240/50-240/60	S6
		110/50-115/50	0A	110	C5		
		220/50-230/50	3D				

To Order a Coil choose Coil Ref + Voltage Code, example: 4828 for 24 VDC = **481000C2**

More voltage possibilities can be found in the table of voltage codes at the end of the coil section.

These coils must be used with suitable housings, see examples below:

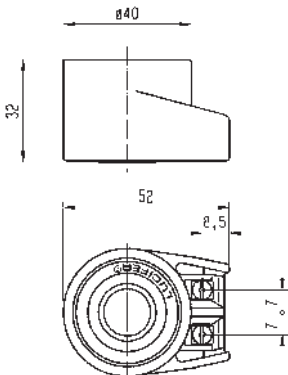

Ref. 4270 - Protection **IP 44** according to IEC / EN 60529 standard (with cable gland)



Ref. 4538 - Protection **IP 67** according to IEC / EN 60529 standard



HIGH POWER COILS 40 mm

This coil can be mounted with every Parker Solenoid Valves corresponding to the specified Coil Group.

See column "Coil Group" within valve pages.

They can be mounted with all metal housings.

The coil winding is completely encapsulated in synthetic material.

Easy mounting in confined spaces. Electrical connection with screw terminals for wire up to 1.5 mm².

Coils conform to the IEC/CENELEC safety standards and complies with European low-voltage directive.



Specification		High Power	
Reference		481044	
Coil Group		2.0 / 2.2	
Class of insulation		F 155°C	
Ambient temperature		-40°C to +50°C The application is limited also by the temperature range of the valve.	
Elect. Power	DC	Pn (hot)	-
		P (cold) 20°C	-
	AC	Pn (holding)	14 W
		Attraction cold	56 VA (20 W)
Weight		130 g	
Voltages "Un"		VAC/Hz	Code
-10% to +10% of the Un		24/50	A2
		110/50	A5
		220/50	A7
		230/50	F4

To Order a Coil choose Coil Ref + Voltage Code, example: 481044 for 24VAC/50Hz = 481044A2

More voltage possibilities can be found in the table of voltage codes at the end of the coil section.

These coils must be used with suitable housings, see examples below:

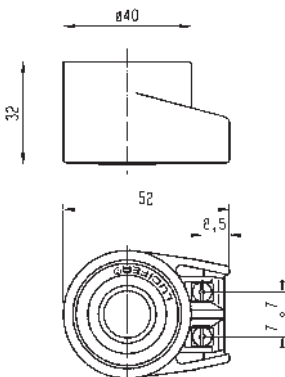

Ref. 4270 - Protection IP 44 according to IEC / EN 60529 standard (with cable gland)



Ref. 8520 - Protection IP 67 according to IEC / EN 60529 standard

COIL GROUP
2.0/2.1
2.2

COILS WITH SCREW TERMINALS



HIGH TEMPERATURE COILS 40 mm

These coils can be mounted with every Parker Solenoid Valves corresponding to the specified Coil Group.

See column "Coil Group" within valve pages.

They can be mounted with all metal housings.

The coil winding is completely encapsulated in synthetic material.

Easy mounting in confined spaces. Electrical connection with screw terminals for wire up to 1.5 mm².

Coils conform to the IEC/CENELEC safety standards and complies with European low-voltage directive.



Specification		High Temperature			High Temperature & High Power				
Reference		485100			486265				
Coil Group		2.0 / 2.1			2.0 / 2.2				
Class of insulation		H 180°C							
Ambient temperature		-40°C to +50°C The application is limited also by the temperature range of the valve.							
Elect. Power	DC	Pn (hot)	8 W		14 W				
		P (cold) 20°C	9 W		21 W				
	AC	Pn (holding)	8 W		14 W				
		Attraction cold	32 VA (9 W)		56 VA (20 W)				
Weight		140 g							
Voltages "Un"		VAC/Hz	Code	VDC	Code	VAC/Hz	Code	VDC	Code
-10% to +10% of the Un		24/50	A2	24	C2	24/50	A2	12	C1
		380/50-440/60	5P			110/50	A5	24	C2
		220/50-230/50	3D			220/50	A7	48	C4
						230/50	F4		

To Order a Coil choose Coil Ref + Voltage Code, example: 485100 for 24VAC/50Hz = 485100A2

More voltage possibilities can be found in the table of voltage codes at the end of the coil section.

These coils must be used with suitable housings, see examples below:

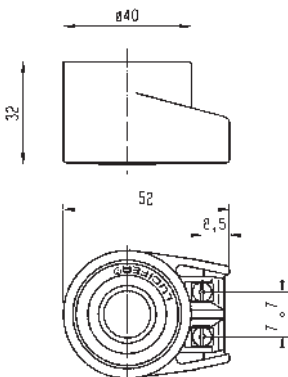

Ref. 4270 - Protection **IP 44** according to IEC / EN 60529 standard (with cable gland)



Ref. 8520 - Protection **IP 67** according to IEC / EN 60529 standard



HIGH TEMPERATURE & HIGH POWER COILS 40 mm OIL BURNER

This coils can be mounted with every Parker Solenoid Valves corresponding to the specified Coil Group. See column "Coil Group" within valve pages.

It can be mounted with all metal housings.

The coil winding is completely encapsulated in synthetic material.

Easy mounting in confined spaces. Electrical connection with screw terminals for wire up to 1.5 mm².

Coil conform to the IEC/CENELEC safety standards and complies with European low-voltage directive.

This coil is used only in safety application according to DIN/EN/ISO 23551-1:2009-10 (Oil burners)



Specification		High Temperature & High Power	
Reference		483824	
Coil Group		14.1	
Class of insulation		H 180°C	
Ambient temperature		-40°C to +50°C The application is limited also by the temperature range of the valve.	
Elect. Power	DC	Pn (hot)	19 W
		P (cold) 20°C	19 W
	AC	Pn (holding)	19 W
		Attraction cold	56 VA (20 W)
Weight		130 g	
Voltages "Un"		VAC/Hz	Code
-10% to +10% of the Un		120/50	A6
		240/50	A8
		110/60	B5
		220/60	B7
		58/50-60/60	T6
		55/60	4J

To Order a Coil choose Coil Ref + Voltage Code, example: 483824 for 120/50 = 483824A6

More voltage possibilities can be found in the table of voltage codes at the end of the coil section.

These coils must be used with suitable housings, Ref: 8760.24 and Ref: 8520.23

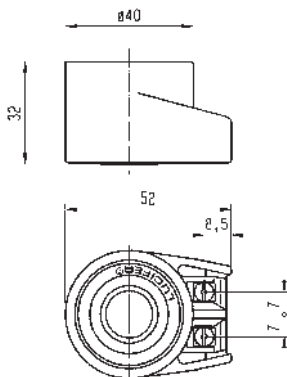

Ref. 8760.24



Ref. 8520.23



HIGH TEMPERATURE & HIGH POWER COILS 40 mm OIL BURNER

This coils can be mounted with every Parker Solenoid Valves corresponding to the specified Coil Group. See column "Coil Group" within valve pages.

It can be mounted with all metal housings.

The coil winding is completely encapsulated in synthetic material.

Easy mounting in confined spaces. Electrical connection with screw terminals for wire up to 1.5 mm².

Coil conform to the IEC/CENELEC safety standards and complies with European low-voltage directive.

This coil is used only in safety application according to DIN/EN/ISO 23551-1:2009-10 (Oil burners)



Specification		High Temperature & High Power	
Reference		483541	
Coil Group		14.3	
Class of insulation		H 180°C	
Ambient temperature		-40°C to +50°C The application is limited also by the temperature range of the valve.	
Elect. Power	DC	Pn (hot)	20 W
		P (cold) 20°C	20 W
	AC	Pn (holding)	20 W
		Attraction cold	56 VA (20 W)
Weight		130 g	
Voltages "Un"		VAC/Hz	Code
-10% to +10% of the Un		120/50	A6
		240/50	A8
		110/60	B5
		220/60	B7
		58/50-60/60	T6
		55/60	4J

To Order a Coil choose Coil Ref + Voltage Code, example: 483541 for 120/50 = 483541A6

More voltage possibilities can be found in the table of voltage codes at the end of the coil section.

These coils must be used with suitable housings, Ref: 8760.24 and Ref: 8520.23

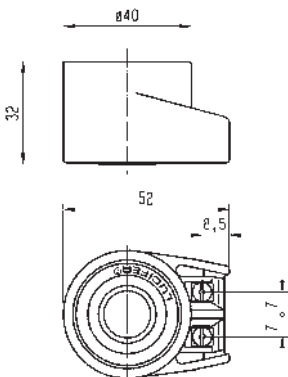

Ref. 8760.24



Ref. 8520.23



COIL DOUBLE FREQUENCY 40 mm H CLASS

This coil can be mounted with every Parker Solenoid Valves corresponding to the specified Coil Group. See column "Coil Group" within valve pages.

They can be mounted with all metal housings.

The coil winding is completely encapsulated in synthetic material.

Easy mounting in confined spaces. Electrical connection with screw terminals for wire up to 1.5 mm².

Coils conform to the IEC/CENELEC safety standards and complies with European low-voltage directive.



Specification		Double Frequency 100 V - 200 V	
Reference		488553	
Coil Group		2.0/2.1	
Class of insulation		H 180°C	
Ambient temperature		-40°C to +50°C The application is limited also by the temperature range of the valve.	
Elect. Power	DC	Pn (hot)	-
		P (cold) 20°C	-
	AC	Pn (holding)	9 W
		Attraction cold	-
Weight		130 g	
Voltages "Un"		VAC/Hz	Code
-10% to +10% of the Un		100/50-60	P1
		200/50-60	P6

To Order a Coil choose Coil Ref + Voltage Code, example: 488553 for 110/50-60 = 488553P1
More voltage possibilities can be found in the table of voltage codes at the end of the coil section.

These coils must be used with suitable housings, see examples below:

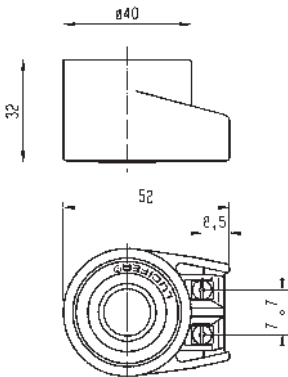

Ref. 4270 - Protection IP 44



Ref. 8520 - Protection IP 54



BISTABLE COILS 40 mm FOR IMPULSE APPLICATIONS

These coils can be mounted with every Parker solenoid valves corresponding to the specified Coil Group.

See column "Coil Group" within valve pages.

These coils are specially designed for Lucifer® bistable (or impulse or magnetic latch) solenoid valves for Heating Applications.

They can be mounted only with the Lucifer® metallic housing 4269 or 4538. The coil winding is completely encapsulated in synthetic material. Easy mounting in confined spaces. Electrical connection with screw terminals for wire up to 1.5 mm².

Coils conform to the IEC/GENELEC safety standards and complies with European low-voltage directive.



Specification		Bistable (Impulse)		
Reference		484990		485400
Coil Group		4.0		
Class of insulation		F 155°C		
Ambient temperature		-40°C to +50°C The application is limited also by the temperature range of the valve.		
Length of impulses		Switch on (terminals A-B): minimum 50 ms Switch off (terminals A-C): minimum 35 ms		
Electr. Power consumption	DC	Attraction (hot)	-	13 W
		Attraction (cold)	-	19 W
		Release (hot)	-	8 W
		Release (cold)	-	10 W
	AC	Attraction (hot)	11 W	-
		Attraction (cold)	17 W	-
		Release (hot)	4 W	-
		Release (cold)	7 W	-
Weight		150 g		
Voltages "Un"	VAC/Hz	Code	VDC	Code
-10% to +10% of the Un	24/50-24/60	P0	24	C2
	48/50-48/60	S4	48	C4
	110-115/50-115/60	1P	110	C5
	220-230/50-60	3P		

To Order a Coil choose Coil Ref + Voltage Code, example: 485400 for 24 VDC = **485400C2**

More voltage possibilities can be found in the table of voltage codes at the end of the coil section.

These coils must be used with suitable housings, see examples below:

DIAGRAM

Alternating Current

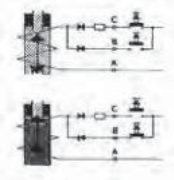

Direct Current

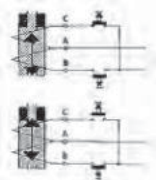

Only an electrical impulse given to terminals A-C reverses the magnetic field. This magnetic field demagnetises the reversible magnet enough to allow the return spring to bring the plunger back to its initial position and close the valve.

Ref. 4269 - Protection **IP 44**

Ref. 4538 - Protection **IP 67**



COILS 12 V - 24 V FOR TRANSPORTATION APPLICATIONS 32 mm

These coils can be mounted with every Parker solenoid valves corresponding to the specified Coil Group. See column "Coil Group" within valve pages.

These coils are specially designed for Lucifer® solenoid valves for Transportation Applications.

They can be mounted with the standard Lucifer® housing 2161 or customized housing.

The coil winding is completely encapsulated in epoxy. Easy mounting and dismantling in confined spaces. Bayonet twist and lock coupling for tight, vibration resistant connection.

Coils conform to the IEC/CENELEC safety standards and complies with European low-voltage directive.



Specification		Transportation			
Reference		496193 with diode		495294 without diode	
Coil Group		13.0			
Degree of protection		IP69K for DIN 400050 part 9			
Ambiant temperature		- 40°C to +120°C The application is limited also by the temperature range of the valve and duty cycle of the valve.			
Insulation Class		F 155°C			
Electrical connection		ISO 15170-A1-2.3-Sn/K2		DIN 72585-A3-2.1	
Elect. Power	DC	Pn (hot)		9 w	
		P (cold) 20°C		-	
	AC	Pn (holding)		-	
		Attraction cold		-	
Weight		147 g			
Voltages "Un"		VDC	Code	VDC	Code
- 30% to + 30% of the Un		12	C1	12	C1
		24	C2	24	C2

To Order a Coil choose Coil Ref + Voltage Code, example: 496193 for 24 VDC = 496193C2

These coils must be used with suitable housings Ref.2168 for 12Vdc and 2169 for 24 VDC.

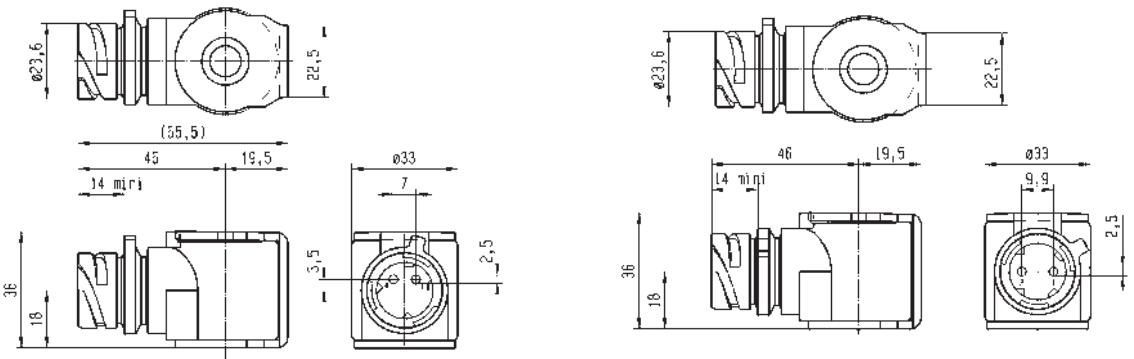

TABLE OF CONTENT

INTRODUCTION

Index for Explosion Proof Electrical Parts.....	442
List of Coil Groups.....	443

COILS

Coils for DIN plug connection.....	446
Coils with flying leads.....	469
Coils with screw terminal.....	474
Coils with ISO-DIN connector.....	481

EXPLOSION PROOF ELECTRICAL PARTS

Level of protection "nAc nCc".....	484
Level of protection "db".....	492
Level of protection "mb".....	494
Level of protection "db mb".....	499
Level of protection "eb".....	504
Level of protection "eb mb".....	505
Level of protection "ia".....	508

HOUSINGS.....	518
---------------	-----

COIL ACCESSORIES.....	522
-----------------------	-----

EXPLOSIVE ENVIRONMENTS.....	524
-----------------------------	-----

COIL APPENDICES

Guidance chart for IS-Barriers.....	534
-------------------------------------	-----



ZONE 2/22

ELECTRICAL PART LOW POWER 22 mm

This coil can be mounted with every Parker ATEX solenoid valves corresponding to the specified Coil Group.

See column "Coil Group" within valve pages.

Application:

Control of solenoid valves in dangerous areas where explosion-proof protection Ex nAc nCc IIC T5 is required.

Benefits:

The synthetic material encapsulation of the coil provides an effective compact housing, offering full protection against dust, oil, water, etc. Small size for ease of mounting in confined spaces.



Reference		495865			
Certificate		LCIE 05 ATEX 6003 X			
Coil Group		1.1			
Type of protection	Gas	II 3 G Ex nAc nCc IIC T5			
	Dust	II 3 D - Ex tc IIIC - T 95°C			
Degree of protection		IP65 (with plug) according to IEC/EN 60529 Standards			
Ambiant temperature		-40°C to +50°C The application is limited also by the temperature range of the valve.			
Insulation Class		F 155°C			
Electrical connection		These coils with connection 2P + G - when mounted together with the supplied Pg 9 plug (delivered with the coil),			
Elect. Power	DC	Pn (hot)	2.5 W		
		P (cold) 20°C	3 W		
	AC	Pn (holding)	2 W		
		Attraction cold	5.7 VA (2.5 W)		
Weight		120 g			
Voltages "Un"		VAC/Hz	Code	VDC	Code
-10% to +10% of the Un		24/50	A2	24	C2
		48/50	A4	48	C4
		110/50-115/50	0A		
		220/50-230/50	3D		

To Order a Coil choose Coil Ref + Voltage Code, example: 495865 for 24 VDC = **495865C2**

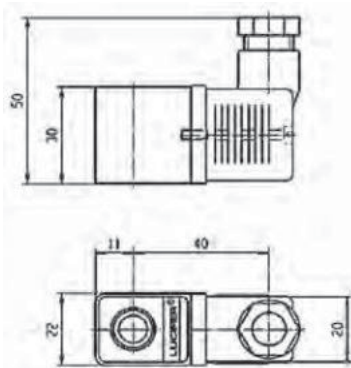



ELECTRICAL PART DOUBLE FREQUENCY 22 mm

This coil can be mounted with every Parker ATEX solenoid valves corresponding to the specified Coil Group.

See column "Coil Group" within valve pages.

Application:

Control of solenoid valves in dangerous areas where explosion-proof protection Ex nAc nCc IIC T5 is required.

Benefits:

The synthetic material encapsulation of the coil provides an effective compact housing, offering full protection against dust, oil, water, etc. Small size for ease of mounting in confined spaces.



ZONE 2/22

Specification		Double Frequency			
Reference		496637			
Certificate		ATEX			
Coil group		1.2			
Type of protection	Gas	Ex nAc nCc IIC T5			
	Dust	II 3 D - Ex tc IIIC - T 95°C			
Degree of protection		IP65 (with plug) according to IEC/EN 60529 Standards			
Ambiant temperature		-20°C to +50°C The application is limited also by the temperature range of the valve.			
Insulation Class		F 155°C			
Elect. Power	DC	Pn (hot)	3 W		
		P (cold) 20°C	-		
	AC	Pn (holding)	3 W		
		Attraction cold	5.7 VA (2.5 W)		
Weight		75 g			
Voltages "Un"		VAC/Hz	Code	VDC	Code
-10% to +10% of the Un		24/50-60	P0	24 V	C2
		110/50-60	P2	48 V	C4
		230/50-60	P9	110 V	C5
		48/50-60	S4		

To Order a Coil choose Coil Ref + Voltage Code, example: 496637 for 24 VDC = **496637C2**

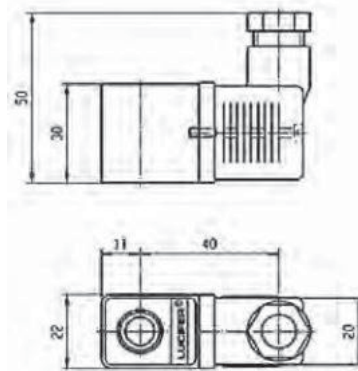



ZONE 2/22

ELECTRICAL PART 32 mm

These coils can be mounted with every Parker ATEX solenoid valves corresponding to the specified Coil Group.
See column "Coil Group" within valve pages.

Application: Control of solenoid valves in dangerous areas where explosion-proof protection Ex nAc nCc IIC T3/T4 is required.

Ease of mounting in confined space - offers shock and corrosion protection-simplifies conversion of existing equipment to other requirements, etc.

Benefits:

The synthetic material encapsulation of the coil provides an effective compact housing, offering full protection against dust, oil, water, etc.

Small size for ease of mounting in confined spaces.



Reference	495870				496110		
Certificate	LCIE 05 ATEX 6003 X						
Coil Group	2.0 / 2.1						
Type of protection	Gas	II 3 G Ex nAc nCc IIC T3/T4			II 3 G Ex nAc nCc IIC T3/T4		
	Dust	II 3 D - Ex tc IIIC - T195°C / T130°C			II 3 D - Ex tc IIIC - T195°C / T130°C		
Degree of protection	IP65 (with plug) according to IEC/EN 60529 Standards						
Insulation Class	F (155°C)						
Duty cycle	100%						
Ambiant temperature	-40°C to +65°C / 50°C The application is limited also by the temperature range of the valve.						
Elect. Power	DC	Pn (hot)	9 W			-	
		P (cold) 20°C	12 W			-	
	AC	Pn (holding)	8 W			9 W	
		Attraction cold	26 VA (9 W)			32 VA (10 W)	
Weight	150 g						
Voltages "Un" -10% to +10% of the Un	VAC/Hz	Code	VDC	Code	VAC/Hz	Code	
	24/50	A2	24	C2	24/50-60	P0	
	48/50	A4	48	C4	48/50-60	S4	
	110/50	A5	110	C5	110/50-60	S5	
	220-230/50	3D			220/50-60	S6	

To Order a Coil choose Coil Ref + Voltage Code, example: 495870 for 24 VDC = **495870C2**

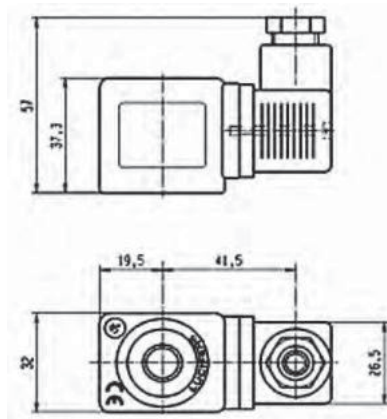



ELECTRICAL PART LOW POWER 32 mm

This coil can be mounted with every Parker ATEX solenoid valves corresponding to the specified Coil Group.
See column "Coil Group" within valve pages.

Application: Control of solenoid valves in dangerous areas where explosion-proof protection Ex nAc nCc IIC T5/T6 is required.

Ease of mounting in confined space - offers shock and corrosion protection-simplifies conversion of existing equipment to other requirements, etc.

Benefits:

The synthetic material encapsulation of the coil provides an effective compact housing, offering full protection against dust, oil, water, etc.

Small size for ease of mounting in confined spaces.



ZONE 2/22

Reference	496125		
Certificate	LCIE 05 ATEX 6003 X		
Coil group	6.0		
Type of protection	Gas	II 3 G Ex nAc nCc IIC T5/T6	
	Dust	II 3 D Ex tc IIIC T95°C/80°C	
Degree of protection	IP65 (with plug) according to IEC/EN 60529 Standards		
Insulation Class	F (155°C)		
Duty cycle	100%		
Ambiant temperature	-40°C to +65°C / 50°C The application is limited also by the temperature range of the valve.		
Elect. Power	DC	Pn (hot)	1.6 W
		P (cold) 20°C	2.1 W
	AC	Pn (holding)	-
		Attraction cold	-
Weight	150 g		
Voltages "Un"	VDC	Code	
-10% to +10% of the Un	24	C2	
	48	C4	
	110	C5	

To Order a Coil choose Coil Ref + Voltage Code, example: 496125 for 24 VDC = **496125C2**

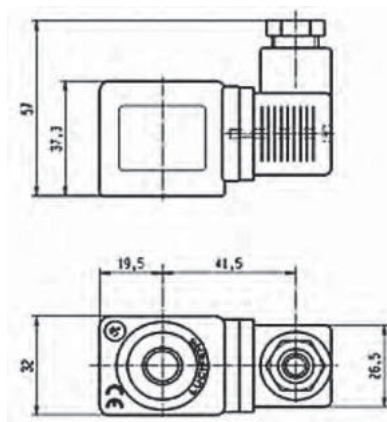



ELECTRICAL PART 32 mm

This coil can be mounted with every Parker ATEX solenoid valves corresponding to the specified Coil Group.

See column "Coil Group" within valve pages.

Application: Control of solenoid valves in dangerous areas where explosion-proof protection Ex nAc nCc IIC T3/T4 is required.

Ease of mounting in confined space - offers shock and corrosion protection-simplifies conversion of existing equipment to other requirements, etc.

Benefits:

The synthetic material encapsulation of the coil provides an effective compact housing, offering full protection against dust, oil, water, etc.

Small size for ease of mounting in confined spaces.



Specification		32 mm Coil "nAc nCc"			
Reference		495875			
Certificate		LCIE 05 ATEX 6003 X			
Coil Group		3.0			
Type of protection	Gas	II 3 G Ex nAc nCc IIC T3/T4			
	Dust	II 3 D - Ex tc IIC - T195°C / T130°C			
Degree of protection		IP65 (with plug) according to IEC/EN 60529 Standards			
Insulation Class		F 155°C			
Duty cycle		100%			
Ambiant temperature		-40°C to +65°C / 50°C The application is limited also by the temperature range of the valve.			
Elect. Power	DC	Pn (hot)	7 W		
		P (cold) 20°C	-		
	AC	Pn (holding)	6 W		
		Attraction cold	-		
Weight		180 g			
Voltages "Un"		VAC/Hz	Code	VDC	Code
-10% to +10% of the Un		220-230/50	3D	24	C2

To Order a Coil choose Coil Ref + Voltage Code, example: 495875 for 24 VDC = 495875C2

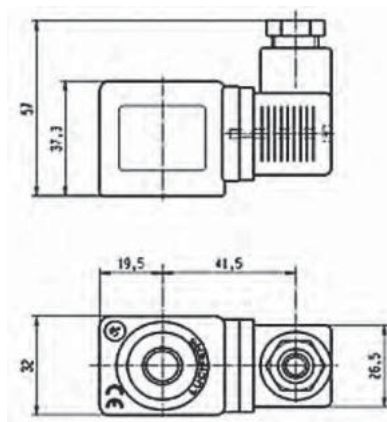

COIL GROUP

2.0/2.2

**NON ENCAPSULATED
ELECTRICAL PARTS
"nAc nCc"**



ELECTRICAL PART 32 mm

This coil can be mounted with every Parker ATEX solenoid valves corresponding to the specified Coil Group.
See column "Coil Group" within valve pages.

Application: Control of solenoid valves in dangerous areas where explosion-proof protection Ex nAc nCc IIC T3 is required.

Ease of mounting in confined space - offers shock and corrosion protection - simplifies conversion of existing equipment to other requirements, etc.

Benefits:

The synthetic material encapsulation of the coil provides an effective compact housing, offering full protection against dust, oil, water, etc.

Small size for ease of mounting in confined spaces.



ZONE 2/22

Specification		32 mm Coil "nAc nCc"			
Reference		495880			
Certificate		LCIE 05 ATEX 6003X			
Coil Group		2.0 / 2.2			
Type of protection	Gas	II 3 G Ex nAc nCc IIC T3			
	Dust	II 3 D - Ex tc IIC - T195°C			
Degree of protection		IP65 (with plug) according to IEC/EN 60529 Standards			
Insulation Class		H 180°C			
Duty cycle		100%			
Ambiant temperature		-40°C to +65°C The application is limited also by the temperature range of the valve.			
Elect. Power	DC	Pn (hot)	14 W		
		P (cold) 20°C	-		
	AC	Pn (holding)	14 W		
		Attraction cold	-		
Weight		180 g			
Voltages "Un"		VAC/Hz	Code	VDC	Code
-10% to +10% of the Un		24/50	A2	24	C2
		110/50	A5		
		230/50	F4		

To Order a Coil choose Coil Ref + Voltage Code, example: 495880 for 24 VDC = 495880C2

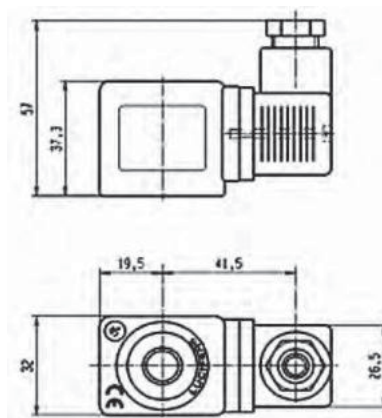



495915 - ELECTRICAL PARTS 50 mm

This coil can be mounted with every Parker ATEX solenoid valves corresponding to the specified Coil Group. See column "Coil Group" within valve pages.

Application: Control of solenoid valves in dangerous areas where explosion-proof protection - Ex nAc nCc IIC T3 is required.

Benefits: Rotatable housing 360°, epoxy varnished steel with internal and external screw terminals for earth connection.

Small size for ease of mounting in confined space. Simplifies conversion of existing equipment to hazardous area requirements.



Reference		495915		
Certificate		LCIE 05 ATEX 6010 X		
Coil group		4.0		
Type of protection	Gas	II 3 G Ex nAc nCc IIC T3		
	Dust	II 3 D - Ex tc IIIC - T 195°C		
Degree of protection		IP67 according to IEC/EN 60529 Standards		
Ambient temperature		-40°C to +65°C The application is limited also by the temperature range of the valve.		
Insulation Class		F 155°C		
Electrical connection		By special cable gland M20 x 1.5 on screw terminals for wires up to 1.5 mm ² . Cable with outside diameter 6.5 mm to 13.5 mm can be simply sealed using the rubber gland with resilient sealing rings supplied		
Consumption Electrique	AC	Attraction (hot)	11 W	-
		Attraction (cold) 20°C	17 W	-
		Release (hot)	4 W	-
		Release (cold) 20°C	7 W	-
	DC	Attraction (hot)	-	13 W
		Attraction (cold) 20°C	-	19 W
		Release (hot)	-	8 W
		Release (cold) 20°C	-	10 W
Weight		320 g		
Duty cycle		Continuous duty solenoid (ED 100%)		
Voltages "Un"		VAC/Hz	Code	VDC
-10% to +10% of the Un		110-115/50-60	1P	24
		220-230/50-60	3P	48
		48/50-60	S4	
		24/50-60	P0	
				Code
				C2
				C4

To Order a Coil choose Coil Ref + Voltage Code,
example: 495915 for 24 VDC = **495915C2**

Schema

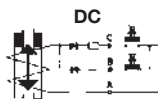
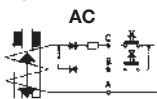

As soon as an electrical impulse is given to the terminals A-B, the electromagnetical force attracts the plunger and simultaneously magnetizes a reversible permanent magnet ring. This magnet retains the plunger in place. It stays in position even without current. Only an electrical impulse given to terminals A-C reserves the magnetic field. This magnetic field demagnetises the reversible magnet enough to allow the return spring to bring the plunger back to its initial position and close the valve.

Switch: Switch on (terminals A-B): Minimum 50 ms (maximum 1 s)
AC: Switch off (terminals A-C): Minimum 35 ms (maximum 1 s)

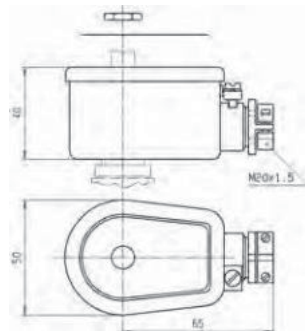

COIL GROUP

2.0/2.2

**INCREASED SAFETY
ELECTRICAL PARTS
"nAc nCc"**



3.5.1 ELECTRICAL PARTS 496155

These coils can be mounted with every Parker solenoid valves corresponding to the specified Coil Group.
See column "Coil Compatibility Group" within valve pages.

Application: Control of solenoid valves in dangerous areas where explosion-proof protection Ex nAc nCc IIC T3 is required.

Benefits: Rotatable housing 360°, epoxy varnished steel with internal and external screw terminals for earth connection.

Small size for ease of mounting in confined space. Simplifies conversion of existing equipment to hazardous area requirements.



ZONE 2/22

Reference		496155			
Certificate		LCIE 05 ATEX 6010 X			
Coil Group		2.0/2.2			
Type of protection	Gas	II 3 G Ex nAc nCc IIC T3			
	Dust	II 3 G D - Ex tc IIC - T 195 °C			
Degree of protection		IP67 according to IEC/EN 60529 Standards			
Ambiant temperature		-40°C to +65°C The application is limited also by the temperature range of the valve.			
Insulation Class		F 155°C			
Electrical connection		By special cable gland or M20x1.5 on screw terminals for wires up to 1.5 mm ² . Cables with outside diameter 6.5 mm to 13.5 mm can be simply sealed using the rubber gland with resilient sealing rings supplied.			
Elect. Power	DC	Pn (hot)	14 W		
		P (cold) 20°C	21 W		
	AC	Pn (holding)	14 W		
		Attraction cold	56 VA (20 W)		
Weight		320 g			
Voltages "Un"		VAC/Hz	Code	VDC	Code
-10% to +10% of the Un		24/50	A2	24	C2
		110/50	A5	48	C4
		230/50	F4		

To Order a Coil choose Coil Ref + Voltage Code, example: 496155 for 24VAC/50Hz = **496155A2**

Fuses:

Both electrical parts have to be connected in series with a safety fuse according to IEC 60127-3.

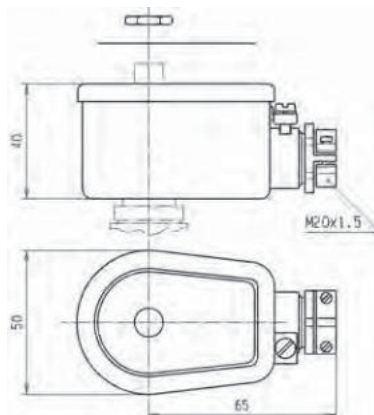



483270 & 483270.02 - ELECTRICAL PARTS 50 mm

These coils can be mounted with every Parker ATEX solenoid valves corresponding to the specified Coil Group. See column "Coil Group" within valve pages.

Application: Control of solenoid valves in dangerous areas where explosion-proof protection Ex db IIC T4 to T6 is required.

Benefits: Rotatable 360°, housing made of cast iron with internal connection chamber: Cover made of aluminium alloy fixed with 4 screws. The electromagnetic control pilot is composed of three main elements: housing, coil and plunger tube including housing plate. Small size for ease of mounting in confined space.



Reference	483270 (M20 x 1.5) 483270.02 (1/2 NPT)			
Certificate	LCIE 02 ATEX 6008 X			
Coil group	11.0			
Type of protection	Gas	II 2 G - Ex db IIC T4/T5/T6		
	Dust	II 2 D - Ex tb IIIC - T130°C/ 95°C/ 80°C		
Degree of protection	IP66 with appropriate cable gland according to IEC/EN 60529 Standards			
Ambient temperature	-40 to +80°C / +75°C / +60°C The application is limited also by the temperature range of the valve.			
Class of insulation	F (155 °)			
Electrical connection	The electrical connection is made within the housing connection chamber on an accessible screw terminal. The cable entry to the connecting chamber is made through 1/2" NPT thread suitable for fitting an approved Ex db IIC cable gland.			
Elect. Power	DC	Pn (hot)	8 W	
		P (cold) 20°C	9 W	
	AC	Pn (holding)	8 W	
		Attraction cold	9 W	
Weight	1100 g (with coil)			
Voltages "Un"	VAC/Hz	Code	VDC	Code
-10% to +10% of the Un	110-115/50-60	1P	24	C2
	220-230/50-60	3P	48	C4
			110	C5

To Order a Coil choose Coil Ref + Voltage Code, example: 483270 for 24 VDC = 483270C2

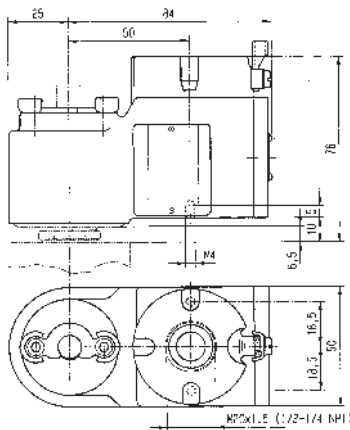

Plunger tube:

The plunger tube is welded to the stainless steel plate and is thus integrated to the housing which is screwed on the valve body. This electrical part is supplied only as complete unit mounted on a valve, as the "Ex db" protection depends on minimum gap between plunger tube, plate and housing.

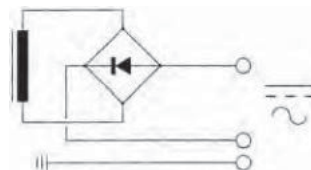



497105 & 497105.02 - ELECTRICAL PARTS

These coils can be mounted with every Parker ATEX solenoid valves corresponding to the specified Coil Group.
See column "Coil Group" within valve pages.

Application: Control of solenoid valves in dangerous areas where explosion-proof protection Ex db IIC T4 / T5 / T6 is required.

Benefits: Rotatable 360°, stainless steel with internal and external screw terminals for earth connection.

Small size for ease of mounting in confined space. Simplifies conversion of existing equipment to hazardous area requirements.



ZONE 1/21

Reference	497105 (M20x1.5) 497105.02 (NPT 1/2")			
Certificate	INERIS 12ATEX0041X - IECEx INE 12.0034X			
Coil Group	10.3			
Type of protection	Gas	II 2 G - Ex db IIC T4 / T5 / T6		
	Dust	II 2 D - Ex tb IIC - 130°C / 95°C / 80°C		
Degree of protection	IP66 (with relevant cable gland) according to IEC/EN 60529 Standards			
Ambient temperature	-50°C to +80°C / +60°C / +40°C The operating temperature of the valve/coil can be limited by that of the valve			
Insulation Class	F 155°C			
Electrical connection	Electric connection is done in the connection chamber on an easily accessible connector terminals. The cable entry to the connection chamber is made through a 1/2" NPT or M20x1.5 thread in which an approved Exdb IIC cable gland must be installed.			
Electrical consumption	DC	Pn (hot)	8 W	
		P (cold) 20°C	9 W	
	AC	Pn (holding)	8 W	
		Attraction cold	9 W	
Voltage Tolerance	+/- 10% of nominal voltage			
Emergising Cuty	ED 100%			
Voltages	VAC/Hz	Code	VDC	Code
	24/50-60	P0	12	C1
	110-115 / 50-60	1P	24	C2
	220-230 / 50-60	3P	48	C4
			110	C5

To Order a Coil choose Coil Ref + Voltage Code, example: 497105 for 24 VDC = **497105C2**

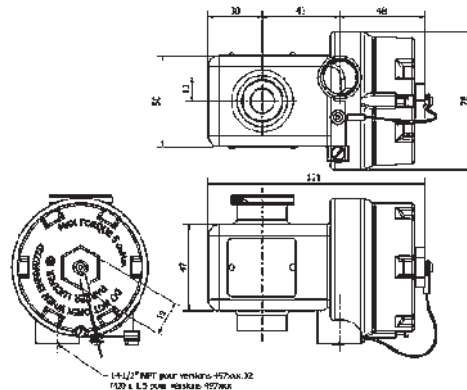



ZONE 1/2/1

ELECTRICAL PART LOW POWER 22 mm

These coils can be mounted with every Parker ATEX solenoid valves corresponding to the specified Coil Group. See column "Coil Group" within valve pages.

Application:

Control of solenoid valves in dangerous areas where explosion-proof protection Ex mb IIC T4 / T5 is required.

Benefits:

Coil and magnetic circuit encapsulated in synthetic material - offering shock and corrosion protection. AC coils with integrated thermal fuse. Small size for ease of mounting in confined spaces.



Reference		482605		482606 or 482606.160*			
Certificate		LCIE 02 ATEX 6014 X - IECEx LCI 07.0026 X					
Coil Group		1.1					
Type of protection	Gas	II 2 G - Ex mb IIC T4 / T5					
	Dust	II 2 D - Ex tb IIIC - T130°C / 95°C					
Degree of protection		IP65 (with plug) according to IEC/EN 60529 Standards					
Ambient temperature		-40°C to +65°C / +40°C		-40°C to +65°C / +35°C			
		The application is limited also by the temperature range of the valve.					
Insulation Class		F 155°C					
Electrical connection		Cable connection (3 x 0.75 mm ²) encapsulated with coil, cable material according to application					
Elect. Power	DC	Pn (hot)	5 W	2.5 W			
		P (cold) 20°C	6.5 W	3 W			
	AC	Pn (holding)	4 W	2 W			
		Attraction cold	8.9 VA (5 W)	5.7 VA (2.5 W)			
		Weight	150 g				
Voltages "Un"		VDC	Code	VAC/Hz	Code	VDC	Code
-10% to +10% of the Un		12	C1	24/50	A2	24	C2
		24	C2	48/50	A4	48	C4
				110/50-115/50	0A	110	C5
				220/50-230/50	3D		

To Order a Coil choose Coil Ref + Voltage Code, example: 482605 for 24 VDC = **482605C2**

* 482606.160 - 6 m cable length - available only in C2 and 3D

* 482606 - 1.5 m cable length

Fuses:

Both electrical parts 482605 & 482606 have to be connected in series with a safety fuse according to CEI 60127-3. Indicating example below:

482605:

- DC: 12 V, 1000 mA - 24 V, 500 mA - 48 V, 200 mA - 110 V, 100 mA
- AC 50 Hz: 24 V, 500 mA - 48 V, 250 mA - 110/115 V, 100 mA - 220/230 V, 3 mA
- AC 60 Hz: 24 V, 630 mA - 110/115 V, 125 mA - 220/230 V, 63 mA

482606:

- DC: 12 V, 400 mA - 24 V, 200 mA - 48 V, 100 mA - 110 V, 50 mA
- AC 50 Hz: 24 V, 250 mA - 48 V, 125 mA - 110/115 V, 63 mA - 220/230 V, 32 mA
- AC 60 Hz: 24 V, 315 mA - 110/115 V, 63 mA - 220/230 V, 32 mA

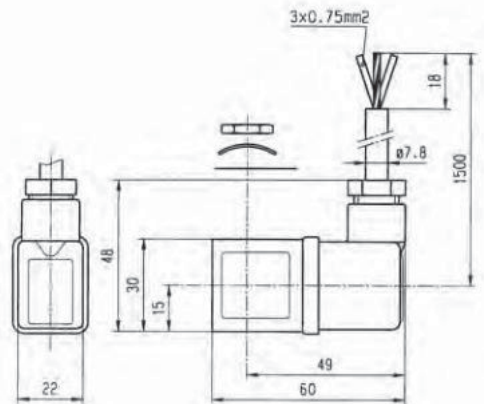

COIL GROUP

2.0/2.1

**ENCAPSULATED
ELECTRICAL PARTS
"mb"**



ELECTRICAL PART 32 mm

This coil can be mounted with every Parker ATEX solenoid valves corresponding to the specified Coil Group. See column "Coil Group" within valve pages.

Application: Control of solenoid valves in dangerous areas where explosion-proof protection Ex mb IIC T4 is required.

Benefits: Coil and magnetic circuit encapsulated in synthetic material offering shock and corrosion protection. AC/DC coils with integrated thermal fuse. DC coils with integrated surge suppression diode.

Small size for ease of mounting in confined spaces. This electrical



ZONE 1/21

Reference		492670*			
Certificate		LCIE 02 ATEX 6015 X			
Coil Group		2.0 / 2.1			
Type of protection	Gas	II 2 G - Ex mb IIC T4			
	Dust	II 2 D - Ex tb IIIC - T130°C			
Degree of protection		IP65 (With DIN Plug connector) according to IEC/EN 60529 standards			
Ambiant temperature		-40°C to +40°C The application is limited also by the temperature range of the valve.			
Class of insulation		F 155°C			
Electrical connection		Cable connection (3 x 1.5 mm ²) encapsulated with coil, cable material according to application			
Elect. Power	DC	Pn (hot)	9 W		
		P (cold) 20°C	12 W		
	AC	Pn (holding)	8 W		
		Attraction cold	26 VA (9 W)		
Weight		320 g			
Voltages "Un"		VAC/Hz	Code	VDC	Code
-10% to +10% of the Un		48/50	A4	24	C2
		230/50	F4	48	C4
				110	C5

To Order a Coil choose Coil Ref + Voltage Code, example: 492670 for 24 VDC = 492670C2

* 492670 3 m cable length

Special conditions:

The supply connection lines have to be fixed and positioned in such a way that they are protected against mechanical damages.

It is necessary to use a safety fuse with a nominal current corresponding to the coil current (max. 3 x nominal according to IEC 60127 and IEC 60269) against short-circuits.

Recommended values:

- DC: 12 V, 1250 mA - 24 V, 630 mA - 48 V, 315 mA - 110 V, 125 mA
- AC 50 Hz: 24 V, 1000 mA - 48 V, 500 mA - 110 V, 250 mA - 230 V, 100 mA
- AC 60 Hz: 240 V, 100 mA

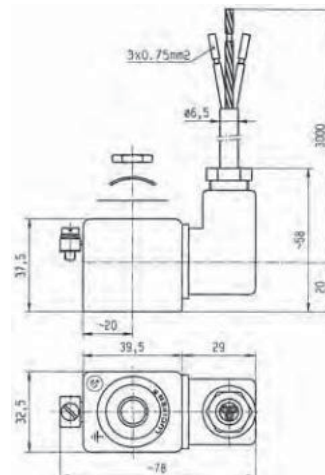



WITH WATER PROOF METAL HOUSING 50 mm

These coils can be mounted with every Parker ATEX solenoid valves corresponding to the specified Coil Group.
See column "Coil Group" within valve pages.

Application: Control of solenoid valves in dangerous areas where explosion-proof protection Ex mb IIC T4/ T5 is required.

Benefits: Epoxy-vernished steel housing - solenoid coil, rectifier (silicium diodes), fuse and varistor protection element are completely encapsulated in the coil housing by means of epoxy resin.

Small size for ease of mounting in confined space. Simplifies conversion of existing equipment to hazardous area requirements.



Reference	492070 (with 3 m cable length) 492070.160 (with 6 m cable length)			
Certificate	LCIE 02 ATEX 6017 X - IECEx LCI 09.0024 X			
Coil Group	2.0 / 2.1			
Type of protection	Gas	II 2 G - Ex mb IIC T4/ T5		
	Dust	II 2 D - Ex tb IIIC - T130 / 95°C		
Degree of protection	IP67 according to IEC/EN 60529 standards			
Ambient temperature	-40°C to +65°C / 40°C The application is limited also by the temperature range of the valve.			
Insulation Class	F 155°C			
Electrical connection	Cable connection (3 x 1.5 mm ²) with cable gland M20 x 1.5, external earth screw connection.			
Elect. Power	DC	Pn (hot)	8 W	
		P (cold) 20°C	10 W	
	AC	Pn (holding)	9 W	
		Attraction cold	11 W	
Weight	500 g			
Voltages "Un"	VAC/Hz	Code	VDC	Code
-10% to +10% of the Un	24/50-60	P0	24	C2
	110/50-60	P2	48	C4
	220/50-60	R5	110	C5
	230/50-60	P9		
	240/50-60	Q1		

To Order a Coil choose Coil Ref + Voltage Code, example: 492070 for 24 VDC = 492070C2

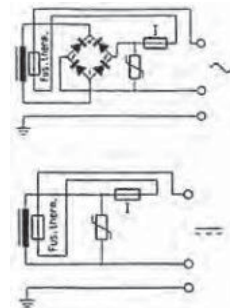
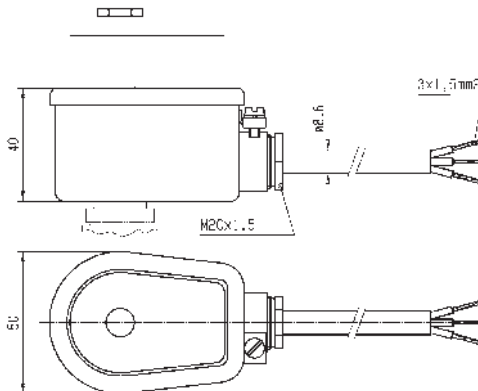

COIL GROUP

2.0/2.1

**ENCAPSULATED
ELECTRICAL PARTS
"mb"**



HZ10 COIL DOUBLE FREQUENCY

This coil can be mounted with every Parker ATEX solenoid valves corresponding to the specified Coil Group.
See column "Coil Group" within valve pages.

Application: Control of solenoid valves in dangerous areas where explosion-proof protection Ex mb IIC T3/T4/T5 is required.

The coil is delivered with a 3m cable.



ZONE 1/21

Specification		Double Frequency			
Reference		HZ10			
Certificate		LCIE 02 ATEX 6020 X - IECEx LCI 08.0027 X			
Coil Group		2.0 / 2.1			
Type of protection	Gas	II 2 G - Ex mb IIC T3/T4/T5			
	Dust	II 2 D - Ex tb IIIC T195°C / 130°C / 95°C			
Degree of protection		IP65 (with plug) according to IEC/EN 60529 Standards			
Ambient temperature		-40°C to +80°C / 65°C / 40°C The application is limited also by the temperature range of the valve.			
Insulation Class		H 180°C			
Duty cycle		100% continuous			
Electrical connection		Cable connection (3 x 1.5 mm ²) with cable gland M20 x 1.5, external earth screw connection.			
Elect. Power	DC	Pn (hot)	8 W		
		P (cold) 20°C	-		
	AC	Pn (holding)	8 W		
		Attraction cold	-		
Weight		299 g			
Voltages "Un"		VAC/Hz	Code	VDC	Code
-10% to +10% of the Un		24/60	B2	12	C1
		110/50-120/60	P3	24	C2
		220/50-240/60	Q3	120	C6

To Order a Coil choose Coil Ref + Voltage Code, example: HZ10 for 24 VDC = HZ10C2

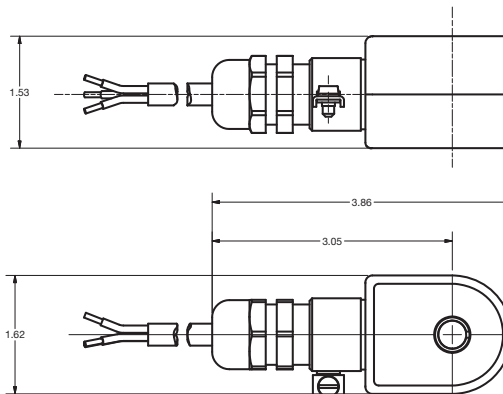

Dimensions in Inches.

ZONE 1/2/1

HZ11 COIL DOUBLE FREQUENCY

This coil can be mounted with every Parker ATEX solenoid valves corresponding to the specified Coil Group.

See column "Coil Group" within valve pages.

Application: Control of solenoid valves in dangerous areas where explosion-proof protection Ex mb IIC T3/T4/T5 is required.

The coil is delivered with a 3m cable.



Specification		Double Frequency			
Reference		HZ11			
Certificate		LCIE 02 ATEX 6020 X - IECEx LCI 08.0027 X			
Coil Group		2.0 / 2.2			
Type of protection	Gas	II 2 G - Ex mb IIC T3/T4/T5			
	Dust	II 2 D - Ex tb IIIC T195°C / 130°C / 95°C			
Degree of protection		IP65 (with plug) according to IEC/EN 60529 Standards			
Ambient temperature		-40°C to + 65°C / 40°C The application is limited also by the temperature range of the valve..			
Insulation Class		H 180 °C			
Duty cycle		100% continuous			
Elect. Power	DC	Pn (hot)	14 W		
		P (cold) 20°C	-		
	AC	Pn (holding)	14 W		
		Attraction cold	-		
Weight		299 g			
Voltages "Un"		VAC/Hz	Code	VDC	Code
-10% to +10% of the Un		24/60	B2	12	C1
		110/50-120/60	P3	24	C2
		220/50-240/60	Q3	120	C6

To Order a Coil: Coil Ref + Voltage Code, example: HZ11 for 24 VDC = **HZ11C2**

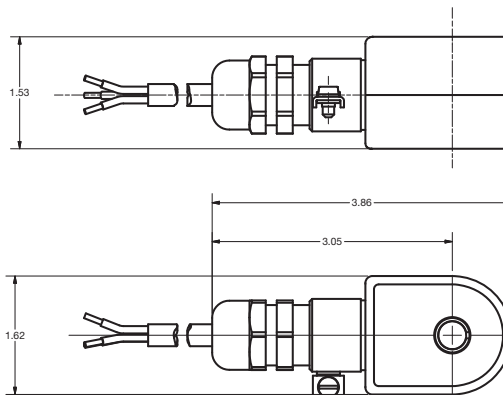

Dimensions in Inches.

COIL GROUPS

6.0

**FLAME PROOF ENCAPSULATED
ELECTRICAL PARTS
"db mb"**



495900 - LOW POWER ELECTRICAL PARTS 37 mm

This coil can be mounted with every Parker ATEX solenoid valves corresponding to the specified Coil Group.
See column "Coil Group" within valve pages.

Application: Control of solenoid valves in dangerous areas where explosion-proof protection Ex db mb IIC T4 to T6 is required.

Benefits: Rotatable 360° fibreglass-reinforced plastic housing (class H). Solenoid coil, rectifier (silicium diodes), fuses and varistor protection are completely encapsulated into the coil housing by epoxy resin for shock and corrosion protection.

The plastic housing is delivered with M20 x 1.5 cable gland certified for use "db" protection. Small size for ease of mounting in confined space.



ZONE 1/21

Reference		495900 (VAC)		495900 (VDC)	
Certificate		LCIE 03 ATEX 6451 X - IECEx LCI 06.0004 X			
Coil Group		6.0			
Type of protection	Gas	II 2 G - Ex db mb IIC T4 / T5 / T6		II 2 G - Ex db mb IIC T4 / T5 / T6	
	Dust	II 2 D Ex tb IIC - 130°C / 95°C / 80°C		II 2 D Ex tb IIC - T130°C / 95°C / 80°C	
Degree of protection		IP67 according to IEC/EN 60529 Standards			
Ambient temperature		-40°C to +80°C / 55°C / 40°C		-40°C to +80°C / 65°C / 55°C	
		The application is limited also by the temperature range of the valve.			
Class of insulation		H (180 °)			
Electrical connection		Electric connection is done in the connection box on an easily accessible connector terminals. The introduction of the cable (Ø min 5 mm, Ømax. 11 mm, section max. 2.5 mm ²) in the connection box passes by the built in M20 x 1.5 cable gland			
Elect. Power	DC	Pn (hot)	-		2 W
		P (cold) 20°C	-		2.5 W
	AC	Pn (holding)	2.5 W		-
		Attraction cold	3 W		-
Voltages "Un"		VAC/Hz	Code	VDC	Code
-10% to +10% of Un for AC - 10 % to + 10 % for Un DC.		24/50	A2	24	C2
		48/50	A4	48	C4
		115/50	E5	110	C5
		230/50	F4		

To Order a Coil: Coil Ref + Voltage Code, example: 495900 for 24 VDC = **495900C2**

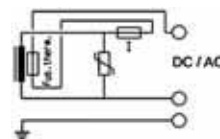
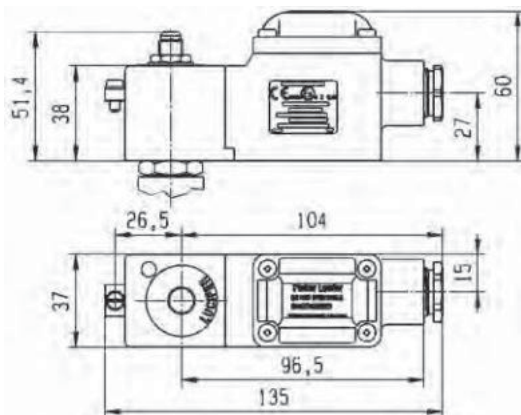



495905 - ELECTRICAL PARTS 37 mm

These coils can be mounted with every Parker ATEX solenoid valves corresponding to the specified Coil Group.
See column "Coil Group" within valve pages.

Application: Control of solenoid valves in dangerous areas where explosion-proof protection Ex db mb IIC T4 is required.

Benefits: Rotatable 360° fibreglass-reinforced plastic housing (class H). Solenoid coil, rectifier (silicium diodes), fuses and varistor protection are completely encapsulated into the coil housing by epoxy resin for shock and corrosion protection.

The plastic housing is delivered with M20 x 1.5 cable gland certified for use "db" protection. Small size for ease of mounting in confined space.



Reference		495905		495905.05*	
Certificate		LCIE 03 ATEX 6451 X - IECEx LCI 06.0004 X			
Coil Group		2.0 / 2.1			
Type of protection	Gas	II 2 G - Ex db mb IIC T4			
	Dust	II 2 D - Ex tb IIIC - 130°C			
Degree of protection		IP67 according to IEC/EN 60529 Standards			
Ambient temperature		-40°C to +80°C The application is limited also by the temperature range of the valve.			
Class of insulation		H (180 °)			
Electrical connection		Electric connection is done in the connection box on an easily accessible connector terminals. The introduction of the cable (Ø min 5 mm, Ømax. 11 mm, section max. 2.5 mm²) in the connection box passes by the built in M20 x 1.5 cable gland.			
Elect. Power	DC	Pn (hot)	8 W		
		P (cold) 20°C	9 W		
	AC	Pn (holding)	8 W		
		Attraction cold	9 W		
Voltages "Un"		VAC/Hz	Code	VDC	Code
-10% to +10% of Un for AC		24/50	A2	24	C2
-10% to +10% for Un DC		48/50	A4	48	C4
		115/50	E5	110	C5
		230/50	F4		

To Order a Coil choose Coil Ref + Voltage Code, example: 495905 for 24 VDC = **495905C2**

* 495905.05 available only in C4

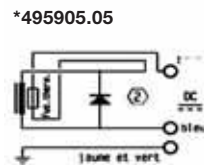
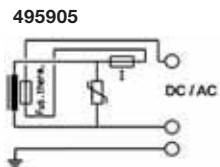
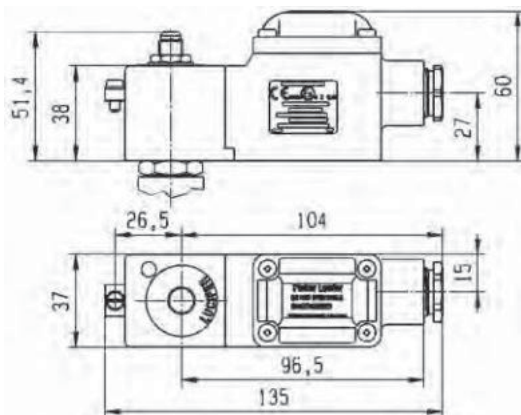

COIL GROUP

10.2/10.1

**FLAME PROOF ENCAPSULATED
ELECTRICAL PARTS**
"db mb"



496555 & 496560 - ELECTRICAL PARTS 37 mm

These coils can be mounted with every Parker ATEX solenoid valves corresponding to the specified Coil Group.
See column "Coil Group" within valve pages.

Application: Control of solenoid valves in dangerous areas where explosion-proof protection Ex db mb IIC T4 to T6 is required.

Benefits: Rotatable 360° fibreglass-reinforced plastic housing (class H). Solenoid coil, rectifier (silicium diodes), fuses and varistor protection are completely encapsulated into the coil housing by epoxy resin for shock and corrosion protection.

The plastic housing is delivered with M20 x 1.5 cable gland certified for use "db" protection. Small size for ease of mounting in confined space.



ZONE 1/21

Reference		496555			496560				
Certificate		LCIE 07 ATEX 6075 X - IECEx LCI 07.0014X							
Coil Group		10.2			10.1				
Type of protection	Gas	II 2 G - Ex db mb IIC T4 / T5 / T6			II 2 G - Ex db mb IIC T4				
	Dust	II 2 D - Ex tb IIIC - T130°C / 95°C / 80°C			II 2 D - Ex tb IIIC - T130°C				
Degree of protection		IP 67 according to IEC/EN 60529 Standards							
Ambiant temperature		-40°C to +65 / 50 / 35°C			-40°C to +65°C				
Class of insulation		H (180 °)							
Electrical connection		Electric connection is done in the connection box on an easily accessible connector terminals. The introduction of the cable (Ø min 5 mm, Ømax. 11 mm, section max. 2.5 mm²) in the connection box passes by the built in M20 x 1.5 cable gland.							
Elect. Power	DC	Pn (hot)	-	6 W	-	-	8 W		
		P (cold) 20°C	-	7.5 W	-	-	10.5 W		
	AC	Pn (holding)	6 W	-	-	8 W	-		
		Attraction cold	7.5 W	-	-	10.5 W	-		
Voltages "Un"		VAC/Hz	Code	VDC	Code	VAC/Hz	Code	VDC	Code
-10% to +10% of the Un		230/50-60	P9	24	C2	230/50-60	P9	24	C2
		110/50-60	P2	48	C4	110/50-60	P2	48	C4
		24/50-60	P0	110	C5	24/50-60	P0	110	C5
		48/50-60	S4			48/50-60	S4		

To Order a Coil choose Coil Ref + Voltage Code, example: 496555 for 24 VDC = 496555C2

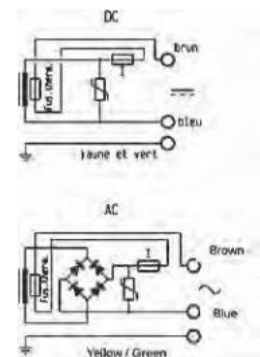
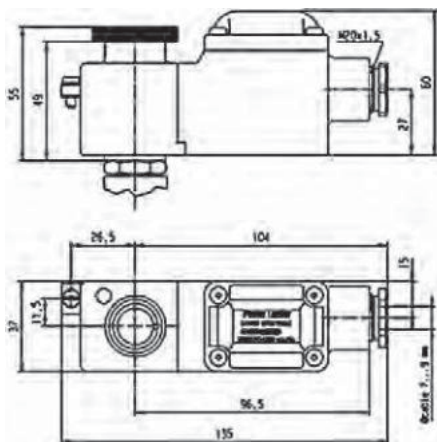

**FLAME PROOF ENCAPSULATED
ELECTRICAL PARTS
"db mb"**



ZONE 1/21

496700 & 496800 - ELECTRICAL PARTS 37 mm

These coils can be mounted with every Parker ATEX solenoid valves corresponding to the specified Coil Group.
See column "Coil Group" within valve pages.

Application: Control of solenoid valves in dangerous areas where explosion-proof protection Ex db mb IIC T4 to T6 is required.

Benefits: Rotatable 360° fibreglass-reinforced plastic housing (class H). Solenoid coil, rectifier (silicium diodes), fuses and varistor protection are completely encapsulated into the coil housing by epoxy resin for shock and corrosion protection.

The plastic housing is delivered with 1/2" NPT or M20 x 1.5 threaded hole for wide range of cable glands. Small size for ease of mounting in confined space.



Reference		496700 or 496700.02 (NPT)			496800 or 496800.02 (NPT)				
Certificate		LCIE 10 ATEX 3059 X - IECEx LCI 10.0023X							
Coil Group		10.2			10.1				
Type of protection	Gas	II 2 G - Ex db mb IIC T4 / T5 / T6			II 2 G - Ex db mb IIC T4				
	Dust	II 2 D - Ex tb IIIC - T130 / 95 / 80°C			II 2 D - Ex tb IIIC - T130°C				
Degree of protection		IP67 according to IEC/EN 60529 Standards							
Ambiant temperature		-40°C to +35°C / +50°C / +65°C			-40°C to +65°C				
Class of insulation		H (180°)							
Electrical connection		Electric connection is done in the connection box passes through a 1/2 NPT or M20x1.5 thread in which a certified Ex dB IIC cable gland must be installed							
Elect. Power	DC	Pn (hot)	-	6 W	-	8 W	-		
		P (cold) 20°C	-	7.5 W	-	10.5 W	-		
	AC	Pn (holding)	6 W	-	8 W	-	-		
		Attraction cold	7.5 W	-	10.5 W	-	-		
Voltages "Un"		VAC/Hz	Code	VDC	Code	VAC/Hz	Code	VDC	Code
-10% to +10% of the Un		230/50-60	P9	24	C2	230/50-60	P9	24	C2
		110/50-60	P2	48	C4	110/50-60	P2	48	C4
		24/50-60	P0	110	C5	24/50-60	P0	110	C5
		48/50-60	S4			48/50-60	S4		

To Order a Coil choose Coil Ref + Voltage Code, example: 496700 for 24 VDC = **496700C2**

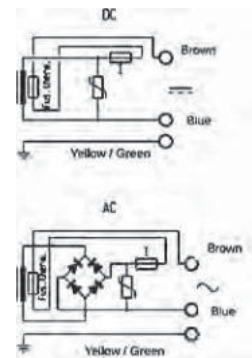
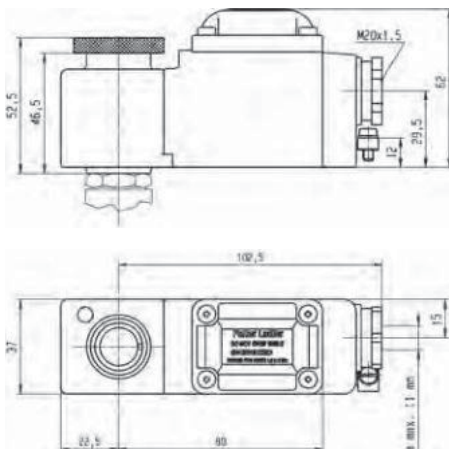

COIL GROUP

2.0/2.1

**FLAME PROOF ENCAPSULATED
ELECTRICAL PART**
"db mb"



493640 OR HZ09 - ELECTRICAL PARTS

This coil can be mounted with every Parker ATEX solenoid valves corresponding to the specified Coil Group.
See column "Coil Group" within valve pages.

Application: Control of solenoid valves in dangerous areas where explosion-proof protection Ex db mb IIC T4/T5 is required.

Benefits: Metal armature encapsulated in synthetic material provides high shock and corrosion protection.

Small size for ease of mounting in confined space.



ZONE 1/21

Reference		493640 493640.60*			
Certificate		LCIE 02 ATEX 6009 X			
Coil Group		2.0 / 2.1			
Type of protection	Gas	II 2 G Ex db mb IIC T4/T5			
	Dust	II 2 D - Ex tb IIIC - T130°C / T95°C			
Degree of protection		IP65 according to IEC/EN 60529 Standards			
Ambiant temperature		- 40°C to +100°C / +75°C The application is limited also by the temperature range of the valve.			
Class of insulation		F (155 °)			
Electrical connection		Special "Ex db" cable gland, galvanized steel, with EPDM sealing. (EPR) cable, outside diameter 7.3 ± 0.5 mm and 3000 mm long.			
Elect. Power	DC	Pn (hot)	8 W		
		P (cold) 20°C	9 W		
	AC	Pn (holding)	8 W		
		Attraction cold	32 VA (9 W)		
Weight		500 g			
Voltages "Un"		VAC/Hz	Code	VDC	Code
- 15% to +10% of the Un		110/50	A5	24	C2
		110-120/50-60	P3	48	C4
		220-240/50-60	Q3	120	C6

To Order a Coil choose Coil Ref + Voltage Code, example: 493640 for 24 VDC = **493640C2**

* 493640.60 - 6 m cable length - Available only in C2

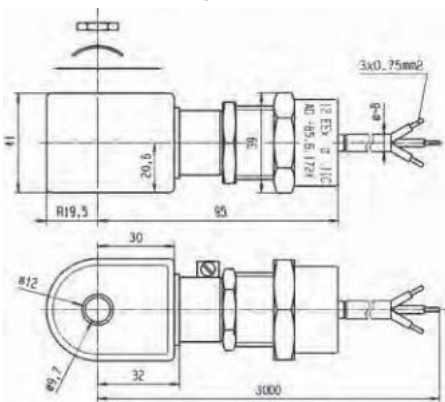

Fuses

This electrical part is equipped with a standard thermal cut-off fuse on all models and voltages

This electrical part must be connected in series with a safety fuse according to IEC 60127-3.

DC: 24V, 400 mA

AC: 110/50-120/60, 200 mA
220/50-240/60, 100 mA
230/50, 95 mA



ZONE 1/2/1

483371 & 494040 - ELECTRICAL PARTS 50 MM

This coil can be mounted with every Parker ATEX solenoid valves corresponding to the specified Coil Group. See column "Coil Group" within valve pages.

Application: Control of solenoid valves in dangerous areas where explosion-proof protection Ex eb IIC T3 orT4 is required.

Benefits: Rotatable housing 360°, epoxy varnished steel with internal and external screw terminals for earth connection.

Small size for ease of mounting in confined space. Simplifies conversion of existing equipment to hazardous area requirements.



Reference		483371				494040				
Certificate		LCIE 02 ATEX 6011 X				LCIE 02 ATEX 6013 X				
Coil Group		2.0 / 2.1								
Type of protection	Gas	II 2 G - Ex eb IIC T4				II 2 G - Ex eb IIC T3 / T4				
	Dust	II 2 D - Ex tb IIIC - T130°C				II 2 D - Ex tb IIIC - T195°C / T130 °C				
Degree of protection		IP67 according to IEC/EN 60529 Standards								
Ambiant temperature		-40°C to +65°C The application is limited also by the temperature range of the valve.				-40°C to +90°C / to +65°C				
Class of insulation		F 155°C				H (180°)				
Electrical connection		By special cable gland or M20 x 1.5 "Ex eb" on screw terminals for wires up to 1.5 mm². Cables with outside diameter 6.5 mm to 13.5 mm can be simply sealed using the rubber gland with resilient sealing rings supplied.								
Elect. Power	DC	Pn (hot)	8 W				8 W			
		P (cold) 20°C	9 W				9 W			
	AC	Pn (holding)	8 W				8 W			
		Attraction cold	32 VA (9 W)				32 VA (9 W)			
Weight		320 g								
Voltages "Un"		VAC/Hz	Code	VDC	Code	VAC/Hz	Code	VDC	Code	
-10% to +10% of the Un		24/50	A2	24	C2	220-230/50	3D	24	C2	
		48/50	A4	48	C4					
		110-115/50	0A	110	C5					
		220-230/50	3D							

To Order a Coil choose Coil Ref + Voltage Code, example: 483371 for 24 VDC = **483371C2**

Fuses:

Both electrical parts have to be connected in series with a safety fuse according to IEC 60127-3.

483371:

DC: 24 V, 400 mA - 48V, 250 mA - 110 V, 100 mA
AC 50HZ: 24 V, 630 mA - 48V, 315 mA - 110 V, 160 mA - 220/230 V, 80 mA

494040:

DC: 12 V, 400 mA - 24V, 200 mA - 48 V, 100 mA - 110V, 50 mA
AC 50HZ: 24 V, 250 mA - 48V, 125 mA - 110/115 V, 63 mA - 220/230 V, 32 mA

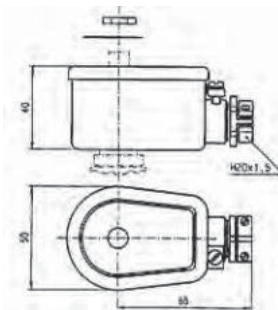

INCREASED SAFETY
AND ENCAPSULATED
ELECTRICAL PARTS "eb mb"



492310 - ELECTRICAL PARTS 50 mm

This coil can be mounted with every Parker ATEX solenoid valves corresponding to the specified Coil Group.
See column "Coil Group" within valve pages.

Application: Control of solenoid valves in dangerous areas where explosion-proof protection Ex eb mb II T4 to T5 is required.

Benefits: Rotatable 360° fibreglass-reinforced plastic housing. Solenoid coil, rectifier (silicium diodes), fuses and varistor protection are completely encapsulated into the coil housing by epoxy resin for shock and corrosion protection.

Small size for ease of mounting in confined space.



Reference		492310			
Certificate		LCIE 02 ATEX 6023 X - IECEx LCI 06.0011 X			
Coil group		10.1			
Type of protection	Gas	II 2 G - Ex eb mb II T4 / T5			
	Dust	II 2 D - Ex tb IIIC - T130°C / T95°C			
Degree of protection		IP66 according to IEC/EN 60529 Standards			
Ambiant temperature		-40°C to +75°C / to +40°C The operating temperature of the valve/coil can be limited by that of the valve			
Class of insulation		F 155°C			
Electrical connection		Connection box with terminals and cable entry via gland M20 x 1.5 - Possibility for additional earth via external screw.			
Elect. Power	DC	Pn (hot)	6 W		
		P (cold) 20°C	7.5 W		
	AC	Pn (holding)	6 W		
		Attraction cold	7.5 W		
Weight		500 g			
Voltages "Un"		VAC/Hz	Code	VDC	Code
-10% to +10% of the Un		24/50-60	P0	24	C2
		48/50-60	S4	48	C4
		230/50-60	P9	110	C5

To Order a Coil choose Coil Ref + Voltage Code, example: 492310 for 24 VDC = 492310C2

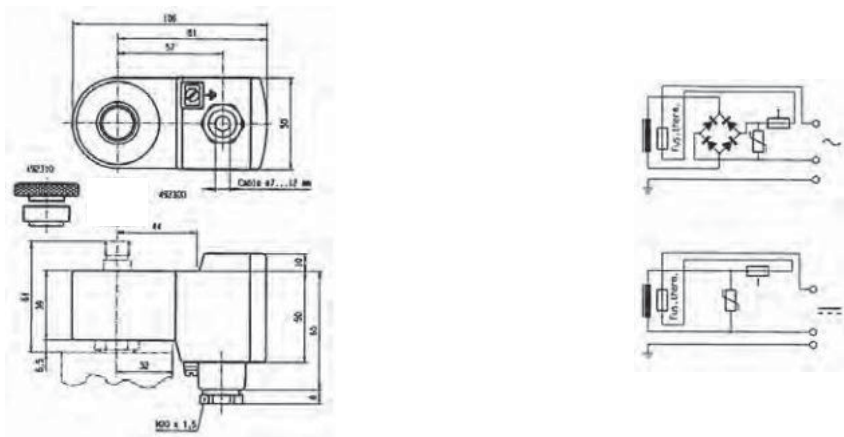

ZONE 1/2/1

492210 - ELECTRICAL PARTS "BOOSTER" 50 mm

These coils can be mounted with every Parker ATEX solenoid valves corresponding to the specified Coil Group. See column "Coil Group" within valve pages.

Application: Control of solenoid valves in dangerous areas where explosion-proof protection - Ex eb mb IIC T5/T6 is required.

Benefits: Rotatable 360° fibreglass-reinforced plastic housing. Solenoid coil, fuses and varistor protection are completely encapsulated into the coil housing by epoxy resin for shock and corrosion protection. Small size for ease of mounting in confined space. Simplifies conversion of existing equipment to hazardous area requirements.

Available only in 24 VDC (suffix code : C2)



Reference	492210	
Certificate	LCIE 02 ATEX 6023 X - IECEx LCI 06.0011 X	
Coil group	9.0	
Type of protection	Gas	II 2 G - Ex eb mb IIC T5 / T6
	Dust	II 2 D - Ex tb IIIC - T95°C / T80°C
Degree of protection	IP66 according to IEC/EN 60529 Standards	
Ambient temperature	-40°C to +75°C / +40°C The operating temperature of the valve/coil can be limited by that of the valve	
Insulation Class	F 155°C	
Electrical connection	Connection box with terminals and cable entry via gland M20 x 1.5 Possibility for additional earth via external screw	
Power consumption DC	1 to 1.8 W according to length of cable	
Attraction current	I min = 60 mA (I nominal = 75 mA)	
Voltage DC	U nominal = 24 VDC (C2), Umin = 21.6 VDC	
Resistance	23 Ω + (R = 270 Ω)	
Inductance	0 mH	
Capacitance	0 μF	
Response time	2 - 4 s	
Weight	500 g	

To Order a Coil choose Coil Ref + Voltage Code, example: 492210 for 24 VDC = 492210C2

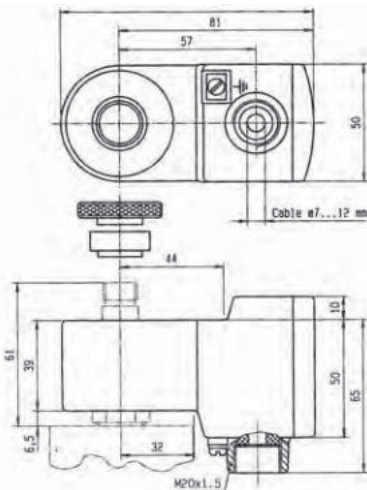

Indications:

Booster for Offshore valves

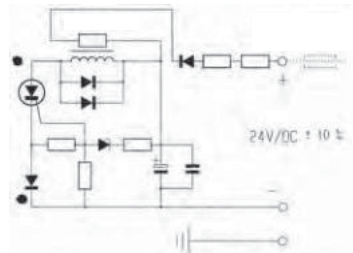

These electrical parts need an external fuse of I = 100 mA

COIL GROUP

2.0/2.1

**INCREASED SAFETY
AND ENCAPSULATED
ELECTRICAL PARTS "eb mb"**



492190 - ELECTRICAL PARTS 50 mm

This coil can be mounted with every Parker ATEX solenoid valves corresponding to the specified Coil Group.
See column "Coil Group" within valve pages.

Application: Control of solenoid valves in dangerous areas where explosion-proof protection Ex eb mb IIC T3 to T4 is required.

Benefits: Rotatable 360°, fiberglass -reinforced plastic housing. Solenoid coil, rectifier (silicium diodes), fuses and varistor protection are completely encapsulated into the coil housing by epoxy resin for shock and corrosion protection.

Small size for ease of mounting in confined space.



ZONE 1/21

Reference	492190			
Certificate	LCIE 02 ATEX 6023 X - IECEx LCI 06.0011 X			
Coil Group	2.0 / 2.1			
Type of protection	Gas	II 2 G - Ex eb mb IIC T3 / T4		
	Dust	II 2 D - Ex tb IIIC - 195°C / 130°C		
Degree of protection	IP66 according to IEC/EN 60529 Standards			
Ambient temperature	-40°C to +75°C / +40°C The operating temperature of the valve/coil can be limited by that of the valve			
Insulation Class	F 155°C			
Electrical connection	Connection box with terminals and cable entry via gland M20 x 1.5 Possibility for additional earth via external screw			
Electrical consumption	DC	Pn (hot)	9 W	
		P (cold) 20°C	11 W	
	AC	Pn (holding)	11 W	
		Attraction cold	13 W	
Weight	320 g			
Voltages "Un" -10% to +10% of the Un	VAC/Hz	Code	VDC	Code
	24/50-60	P0	24	C2
	110/50-60	P2	48	C4
	230/50-60	P9	110	C5

To Order a Coil choose Coil Ref + Voltage Code, example: 492190 for 24 VDC = **492190C2**

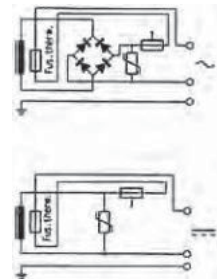
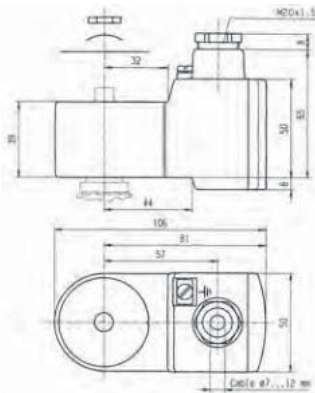



ZONE 0/20

483580 - 483960 ELECTRICAL PARTS 32 mm "IS"

These coils can be mounted with every Parker ATEX solenoid valves corresponding to the specified Coil Group.

See column "Coil Group" within valve pages.

Application: Control of solenoid valves in dangerous areas where explosion-proof protection Ex ia IIC T6 is required.

Benefits: Fully encapsulated assembly comprising a coil, metal armature, three diodes circuit and DIN plug connection.

The encapsulation provides an effective compact housing offering full protection against dust, oil, water, etc.

Small size for ease of mounting in confined space. Available only in 28 VDC (suffix code : N7)



Reference (without plug) (with plug)	483580.01 483960.01	
Certificate	LCIE 02 ATEX 6065 X - IECEx LCI 07.0025 X	
Coil Group	7.0	
Type of protection	Gas	II 1 G - Ex ia IIC - T6
	Dust	II 1 D - Ex ta IIIC - T80°C
Degree of protection	IP65 with plug according to IEC/EN 60529 Standards	
Ambiant temperature	- 40°C à + 55°C The operating temperature of the valve/coil can be limited by that of the valve.	
Electrical connection	The coil is connected with a 2P + E plug according to EN 175301-803 type A Contact 1 is marked as the positive pole ⊕.	
Maximum supply voltage	28 VDC (N7) - 110 mA The minimum operating voltage at maximum 60°C is 14 VDC.	
Power	DC	Minimum
		Maximum
		500 mW
		3 W
Depending on applied voltage, IS barrier type and resistance of connected cable		
Coil resistance at 20°C	340 Ω	
Impedance	340 Ω	
Apparent inductance	0 mH	
Apparent capacitance	0 μF	
Weight	160 g (with plug)	

To Order a Coil choose Coil Ref + Voltage Code, example: 483580 for 28 VDC = 483580N7

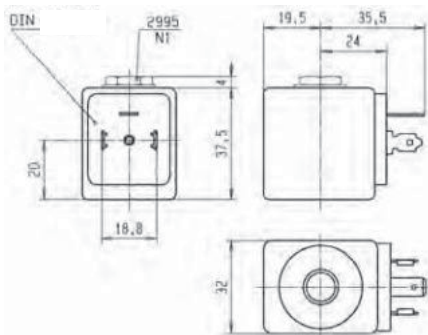

Important

The intrinsically safe supply circuit should have enough capacity in all environmental conditions to assure a **minimum operating current of 35 mA** through the coil.

The minimal holding current is 20 mA.

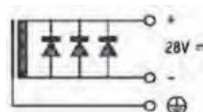

For the barrier compatibility see the corresponding table in in appendix section.

These coil must be used with suitable housing : Ref. 2995

**INTRINSICALLY SAFE
ELECTRICAL PARTS
"ia"**



**495910 - MINIWATT - 0.3 W
ELECTRICAL PARTS "IS" "BOOSTER" 37 mm**

These coils can be mounted with every Parker ATEX solenoid valves corresponding to the specified Coil Group. See column "Coil Group" within valve pages.

Application: Control of solenoid valves in dangerous areas where explosion-proof protection Ex ia IIC T4 to T6 is required.

Benefits: Rotatable 360° fibreglass-reinforced plastic housing (class H). Solenoid coil, rectifier (silicium diodes), fuses and varistor protection are completely encapsulated into the coil housing by epoxy resin for shock and corrosion protection.

Small size for ease of mounting in confined space. Available only in 28 VDC (code: N7).



ZONE 0/20

Reference	495910	
Certificate	LCIE 03 ATEX 6464 X - IECEx LCI 07.0006 X	
Coil Group	8.0	
Type of protection	Gas	II 1 G - Ex ia IIC - T4 / T5 / T6
	Dust	II 1 D - Ex ta IIC T80 / 95 / 130°C
Degree of protection	IP67 according to IEC/EN 60529 Standards	
Ambiant temperature	- 40°C to +80°C / 75°C / 65°C The application is limited also by the temperature range of the valve..	
Class of insulation	H 180°C	
Electrical connection	Electric connection is done in the connection box on an easily accessible connector terminals. The introduction of the cable (Ø min 7 mm, Ømax. 11 mm, section max. 2.5 mm²) in the connection box passes by the built in M20 x 1.5 cable gland	
Maximum supply voltage	28 VDC (N7) - 110 mA	
Power	DC	Minimum
		Maximum
		0.3 W (with 13 VDC) 1.2 W (with 24 VDC)
	Depending on applied voltage, IS barrier type and resistance of connected cable	
Line check	4 mA or 5 VDC max	
Coil resistance at 20°C	Charge ~ 550 Ω - Holding ~ 500 Ω	
Impedance	0 mH	
Apparent inductance	0 µF	
Apparent capacitance		
Response time	2 - 3 s	
Weight	500 g	

To Order a Coil choose Coil Ref + Voltage Code, example: 495910 for 28 VDC = **495910N7**

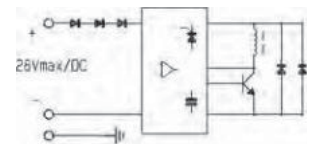
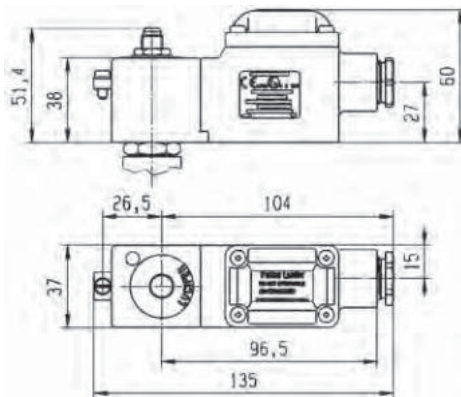



ZONE 0/20

**496565 ELECTRICAL PARTS "BOOSTER"
"IS" 37 mm**

This coil can be mounted with every Parker ATEX solenoid valves corresponding to the specified Coil Group. See column "Coil Group" within valve pages.

Application: Control of solenoid valves in dangerous areas where explosion-proof protection Ex ia IIC T4 to T6 is required.

Benefits: Rotatable 360° fibreglass-reinforced plastic housing (class H). Solenoid coil, rectifier (silicium diodes), fuses and varistor protection are completely encapsulated into the coil housing by epoxy resin for shock and corrosion protection.

The plastic housing is delivered with M20 x 1.5 cable gland. Small size for ease of mounting in confined space. Available only in 28 VDC (code: N7).



Reference	496565	
Certificate	LCIE 08 ATEX 6071 X - IECEx LCI 08.0030 X	
Coil group	9.0	
Type of protection	Gas	II 1 G - Ex ia IIC - T4 / T5 / T6
	Dust	II 1 D - Ex ta IIC - T80 / T95 / T130°C
Degree of protection	IP67 according to IEC/EN 60529 Standards	
Ambiant temperature	- 40°C to +80 / 75 / 65°C The application might also be limited by the temperature range of the valve.	
Electrical connection	Cable connection through a plastic cable gland M20 x 1.5 allowing use of cable diameter from 7 to 12 mm. Additional earth connection possible with external screw terminal.	
Class of insulation	H180°C	
Minimum Courant of function	20 mA	
Minimum voltage of function at 60°C	28 VDC (N7)	
Safety parameters	28 V / 110 mA / 0.77 W	28 V / 280 mA / 1.96 W
Maximum acceptable values: Ui (V) / Ii (mA) / Pi (W)	27 V / 120 mA / 0.81 W	27 V / 320 mA / 2.16 W
	26 V / 135 mA / 0.88 W	26 V / 350 mA / 2.27 W
	25 V / 150 mA / 0.94 W	25 V / 390 mA / 2.43 W
	24 V / 170 mA / 1.02 W	24 V / 430 mA / 2.58 W
Line check	4 mA or 5 VDC max	
Apparent Impedance Typ.	Attraction ~ 600 Ω - Holding ~ 570 Ω	
Apparent Inductance	0 mH	
Apparent Capacitance	0 μF	
Response Time Typ.	2 - 4 s	
Weight	500 g	

To Order a Coil choose Coil Ref + Voltage Code,
example: 496565 for 28 VDC = **496565N7**

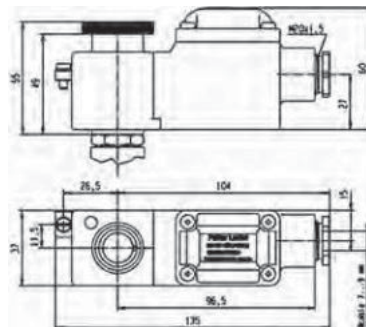



**492965 ELECTRICAL PART
"BOOSTER" "IS" 50 mm**

This coil can be mounted with every Parker ATEX solenoid valves corresponding to the specified Coil Group. See column "Coil Group" within valve pages.

Application: Control of solenoid valves in dangerous areas where explosion-proof protection Ex ia IIC - T6 is required.

Benefits: Rotatable 360° fibreglass-reinforced plastic housing. Solenoid coil, fuses and varistor protection are completely encapsulated into the coil housing by epoxy resin for shock and corrosion protection. Small size for ease of mounting in confined space. Simplifies conversion of existing equipment to hazardous area requirements.

Small size for ease of mounting in confined space. Available only in 28 VDC.



ZONE 0/20

Reference	492965.01 - (Stainless steel fixation) 492965.02 - (Plastic fixation)	
Certificate	LCIE 02 ATEX 6066 X - IECEx LCI 07.0007 X	
Coil Group	9.0	
Type of protection	Gas	II 1 G - Ex ia IIC - T6
	Dust	II 1 D - Ex ta IIIC - T80°C
Degree of protection	IP66 according to IEC/EN 60529 Standards	
Ambient temperature	- 40°C to +65°C The application is limited also by the temperature range of the valve.	
Electrical connection	Cable connection through a plastic or stainless steel cable gland M20 x 1.5 allowing use of cable diameter from 10 to 12 mm. Additional earth connection possible with external screw terminal.	
Class of insulation	H180°C	
Maximum supply voltage	28 VDC (N7) - 110 mA	
Power	DC	Minimum
		Maximum
Depending on applied voltage, IS barrier type and resistance of connected cable		
Line check	4 mA or 5 VDC max	
Coil resistance at 20°C	85 Ω	
Impedance	275 Ω (with 13 VDC) - 260 Ω (with 24 VDC)	
Apparent inductance	0 mH	
Apparent capacitance	0 μF	
Response time	2 - 4 s	
Weight	500 g	

To Order a Coil choose Coil Ref + Voltage Code, example: 492965.01 for 28 VDC = **492965.01N7**

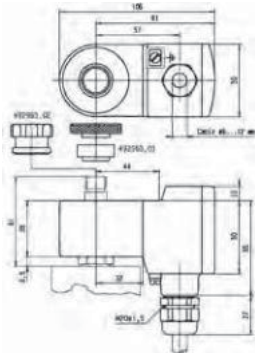

Important

The intrinsically safe supply circuit should have enough capacity in all environmental conditions to assure a **minimum operating current of 29 mA** through the coil.

The minimal holding current is 20 mA.

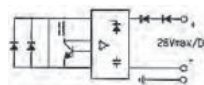

For the barrier compatibility see the corresponding table in appendix section.

**INTRINSICALLY SAFE
ELECTRICAL PARTS
"ia"**



**482870.01 & 492335 "NEMA"
ELECTRICAL PARTS "IS" 50 mm**

These coils can be mounted with every Parker ATEX solenoid valves corresponding to the specified Coil Group.
See column "Coil Group" within valve pages.

Application: Control of solenoid valves in dangerous areas where an explosion-proof protection Ex ia IIC - T6 is required.

Benefits: Rotatable 360° housing, polyamid with fibreglass housing and cover. Coil, electronic circuits and other elements required for intrinsic safety are completely encapsulated in the housing with epoxy material for shock and corrosion protection.

Small size for ease of mounting in confined space.



Reference	482870.01		492335	
Certificate	LCIE 02 ATEX 6024 X		LCIE - FM - CSA	
Coil Group	12.0			
Type of protection	Gas	II 1 G - Ex ia IIC - T6		Cl. I, Div.I, Gr. A, B, C, D, Cl. II, Div.I, Gr. E, F, G
	Dust	II 1 D - Ex ta IIIC - T80°C		
Degree of protection	IP66 according to IEC/EN 60529 Standards		NEMA 4 - 4X	
Ambiant temperature	- 40°C to +65°C		+60°C	
Class of insulation	The application is limited also by the temperature range of the valve. H180°C			
Electrical connection	Cable connection through a stainless steel cable gland M20 x 1.5 allowing use of cable diameter from 10 to 12 mm. Additional earth connection possible with external screw terminal.			
Maximum supply voltage	28 VDC (N7) - 110 mA		30 VDC (L8) - 100 mA	
Power	DC	Minimum	300 mW	
		Maximum	3 W	
Depending on applied voltage, IS barrier type and resistance of connected cable				
Coil resistance at 20°C			295 Ω	
Impedance			345 Ω	
Apparent inductance			0 mH	
Apparent capacitance			0 μF	
Weight			500 g	

To Order a Coil choose Coil Ref + Voltage Code, example: 492335 for 30VDC = **492335L8**

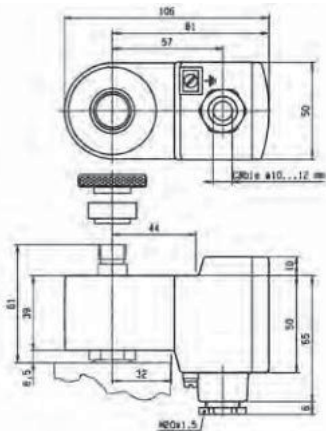

Important

The intrinsic safety supply circuit must have sufficient capacitance in all ambient conditions to guarantee a minimum operating current in excess of **29 mA** across the coil.

The minimum current for holding in the energised position is 20 mA

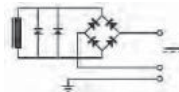

For the barrier compatibility see the corresponding table in appendix section.

ZONE 0/20

COIL GROUP

7.0

**INTRINSICALLY SAFE
ELECTRICAL PARTS
"ia"**



**488650.01 & 490885 "NEMA"
ELECTRICAL PARTS "IS" 50 mm**

This coil can be mounted with every Parker ATEX solenoid valves corresponding to the specified Coil Group.

See column "Coil Group" within valve pages.

Application: Control of solenoid valves in dangerous areas where explosion-proof protection Ex ia IIC - T6 is required.

Benefits: Rotatable 360° housing, polyamid with fibreglass housing and cover. Coil, electronic circuits and other elements required for intrinsic safety are completely encapsulated in the housing with epoxy material for shock and corrosion protection.

Small size for ease of mounting in confined space.



ZONE 0/20

Reference		488650.01	490885
Certificate		LCIE 02 ATEX 6024 X	LCIE / FM / CSA
Coil Group		7.0	
Type of protection	Gas	II 1 G - Ex ia IIC - T6	Cl. I, Div.I, Gr. A, B, C, D, Cl. II, Div.I, Gr. E, F, G
	Dust	II 1 D - Ex ta IIIC - T80°C	
Degree of protection		IP66 according to IEC/EN 60529 Standards	NEMA 4 - 4X
Ambiant temperature		- 40°C to +65°C The operating temperature of the valve/coil can be limited by that of the valve.	60°C
Electrical connection Cable entry through a cable gland M20 x1.5. Screw terminals for leads 3 x 1.5 mm ² max. Additional earth connection possible with external screw terminal			
Class of insulation		H180°C	
Maximum supply voltage		28 VDC (N7) - 110 mA The minimum operating voltage at maximum 60°C is 11.5 VDC.	30 VDC(L8) - 100 mA
Power	DC	Minimum	300 mW
		Maximum	3 W
Dependent on the applied voltage, type of barrier IS and the resistance of the connected cable			
Coil resistance at 20°C		295 Ω	
Impedance		345 Ω	
Apparent inductance		0 mH	
Apparent capacitance		0 μF	
Weight		500 g	

To Order a Coil choose Coil Ref + Voltage Code, example: 490885 for 30VDC = 490885L8

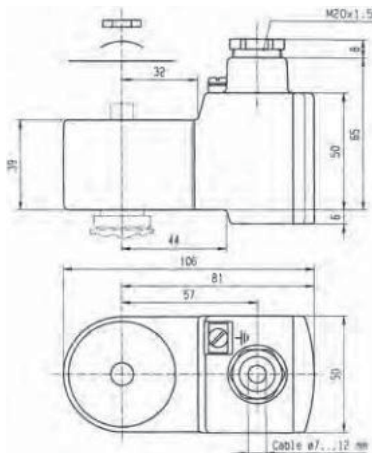

Important

The intrinsically safe supply circuit should have enough capacity in all environmental conditions to assure a **minimum operating current of 29 mA** through the coil.

The minimal holding current is 20 mA.

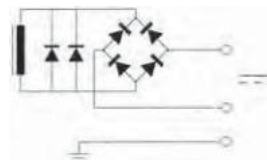

For the barrier compatibility see the corresponding table in appendix section.



**488660.01 & 490890 " NEMA"
ELECTRICAL PARTS "IS" 50 mm**

These coils can be mounted with every Parker ATEX solenoid valves corresponding to the specified Coil Group.
See column "Coil Group" within valve pages.

Application: Control of solenoid valves in dangerous areas where explosion-proof protection Ex ia IIC T6 is required.

Benefits: Rotatable 360° housing, epoxy varnished steel housing and cover. Coil, electronic circuits and other elements required for intrinsic safety are completely encapsulated in the housing with epoxy material for shock and corrosion protection.

Small size for ease of mounting in confined space.



Reference	488660.01		490890	
Certificate	LCIE 02 ATEX 6024 X		LCIE / FM / CSA	
Coil Group			7.0	
Type of protection	Gas	II 1 G - Ex ia IIC - T6	Cl. I, Div.I, Gr. A, B, C, D	
	Dust	II 1 D - Ex ta IIIC - T80°C	Cl. II, Div.I, Gr. E, F, G	
Degree of protection	IP67 according to IEC/EN 60529 Standards		NEMA 4 - 4X	
Ambiant temperature	- 40°C to +65°C		+60°C	
	The operating temperature of the valve/coil can be limited by that of the valve			
Electrical connection	Cable connection (2 x 1 mm ²) with cable gland M20 x1.5, external earth screw connection.			
Class of insulation			H180°C	
Maximum supply voltage	28 VDC - 110 mA (N7)		30 VDC - 100 mA (L8)	
	The minimum operating voltage at maximum 60°C is 11.5 VDC.			
Power	DC	Minimum	300 mW	
		Maximum	3 W	
Dependent on the applied voltage, type of barrier IS and the resistance of the connected cable				
Coil resistance at 20°C			295 Ω	
Impedance			345 Ω	
Apparent inductance			0 mH	
Apparent capacitance			0 μF	
Weight			500 g	

To Order a Coil choose Coil Ref + Voltage Code, example: 490890 for 28 VDC = 490890N7

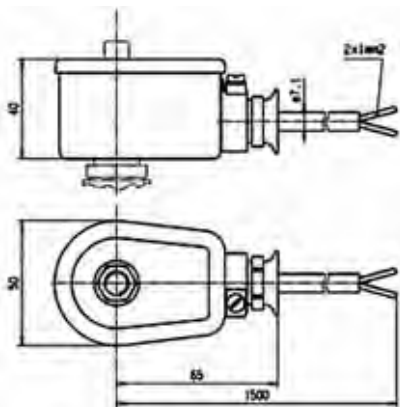

Important

The intrinsic safety supply circuit must have sufficient capacitance in all ambient conditions to guarantee a minimum operating current in excess of **29 mA** across the coil.

The minimum current for holding in the energised position is 20 mA.

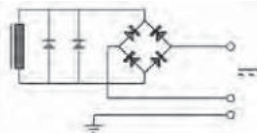

For the barrier compatibility see the corresponding table in appendix section.

COIL GROUP

7.0

INTRINSICALLY SAFE
ELECTRICAL PARTS
"ia"



488670.01 - ELECTRICAL PARTS "IS" 50 mm

This coil can be mounted with every Parker ATEX solenoid valves corresponding to the specified Coil Group.
See column "Coil Group" within valve pages.

Application: Control of solenoid valves in dangerous areas where explosion-proof protection Ex ia IIC - T6 is required.

Benefits: Rotatable 360° housing, epoxy varnished steel housing and cover. Coil, electronic circuits and other elements required for intrinsic safety are completely encapsulated in the housing with epoxy material for shock and corrosion protection.

Small size for ease of mounting in confined space.



ZONE 0/20

Reference	488670.01	
Certificate	LCIE 02 ATEX 6024 X	
Coil group	7.0	
Type of protection	Gas	II 1 G - Ex ia IIC - T6
	Dust	II 1 D - Ex ta IIIC - T80°C
Degree of protection	IP65 according to IEC/EN 60529 Standards	
Ambiant temperature	- 40°C to +65°C The operating temperature of the valve/coil can be limited by that of the valve	
Electrical connection	Cable entry through a cable gland M20 x1.5. Screw terminals for leads 3 x 1.5 mm ² max. Additional earth connection possible with external screw terminal.	
Maximum supply voltage	28 VDC (N7) - 110 mA The minimum operating voltage at maximum 60°C is 11.5 VDC.	
Power	DC	Minimum
		Maximum
		300 mW
		3 W
Dependent on the applied voltage, type of barrier SI and the resistance of the connected cable		
Coil resistance at 20°C	295 Ω	
Impedance	345 Ω	
Apparent inductance	0 mH	
Apparent capacitance	0 μF	
Weight	500 g	

To Order a Coil choose Coil Ref + Voltage Code, example: 488670.01 for 28 VDC = 488670.01N7

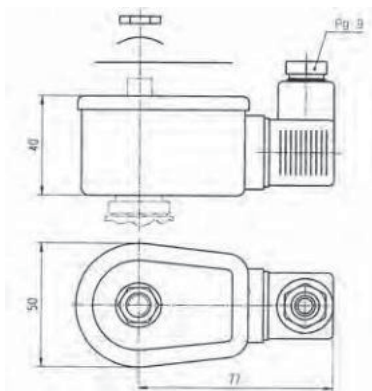

Important

The intrinsic safety supply circuit must have sufficient capacitance in all ambient conditions to guarantee a minimum operating current in excess of **29 mA** across the coil.

The minimum current for holding in the energised position is 20 mA.

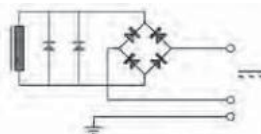

For the barrier compatibility see the corresponding table in appendix section.

TABLE OF CONTENT

INTRODUCTION

Index for Explosion Proof Electrical Parts.....	442
List of Coil Groups.....	443

COILS

Coils for DIN plug connection.....	446
Coils with flying leads.....	469
Coils with screw terminal.....	474
Coils with ISO-DIN connector.....	481

EXPLOSION PROOF ELECTRICAL PARTS

Level of protection "nAc nCc".....	484
Level of protection "db".....	492
Level of protection "mb".....	494
Level of protection "db mb".....	499
Level of protection "eb".....	504
Level of protection "eb mb".....	505
Level of protection "ia".....	508

HOUSINGS.....	518
----------------------	------------

COIL ACCESSORIES.....	522
------------------------------	------------

EXPLOSIVE ENVIRONMENTS.....	524
------------------------------------	------------

COIL APPENDICES

Guidance chart for IS-Barriers.....	534
-------------------------------------	-----

COIL STANDARD HOUSING WITH SCREW TERMINALS

Standard housing:

Reference:	4270
Material:	Epoxy varnished steel with cathaphoresis traitement
Degree of protection:	IP according to IEC/EN 60529 IP 10 with armoured conduit IP 44 with cable gland
Electrical connection:	Can be made with armoured conduit or cable gland M12x1.5. Parts No. 495740 (cable gland M12x1.5) and 484093 to be ordered separately. Grounding connection by screw M3 on the inside of housing base plate.
Weight:	120 g



Benefits:

This metal housing offers the ideal protection against shocks and corrosion- rotatable 360° - easy mounting in confined spaces - single-nut mounting - light weight - simplifies conversion of existing equipment to other requirements.

Application:

The majority of the Lucifer® valves can be fitted with this standard housing, and can be mounted with several compatible Lucifer® coils group.

Compatible coils:

- **481000 - Standard Coil**
8 W Class F (155°C)
- **483520 - Double-Frequency Coil**
9 W Class F (155°C)
- **481044 - Standard High-Power Coil**
14 W Class F (155°C)
- **485100 - Standard High-Temperature Coil**
8 W Class H (180°C)
- **486265 - High-Temperature and High-Power Coil**
14 W Class H (180°C)

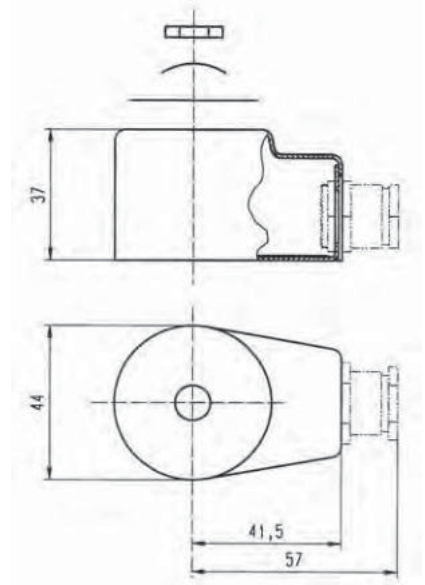

HOUSING

4269**HOUSING FOR BISTABLE
(IMPULSE) COILS****Housing for bistable coil:**

Reference:	4269
Material:	Epoxy varnished steel
Degree of protection:	IP according to IEC/EN 60529 IP 10 with armoured conduit IP 44 with cable gland
Electrical connection:	Can be made with armoured conduit or cable gland M12x1.5. Parts No. 484092 and 484093 to be ordered separately. Grounding connection by screw M3 on the inside of housing base plate.
Weight:	120 g

**Benefits:**

This metal housing offers the ideal protection against shocks and corrosion- rotatable 360° - easy mounting in confined spaces - single-nut mounting - light weight - simplifies conversion of existing equipment to other requirements.

Application:

This housing is specially designed for group 4.0 coils and can be mounted only with valves controlled by electrical impulses.

Compatible coils:

- **484990 - Impulse coil for AC**
11 W Class F (155°C)
- **485400 - Impulse coil for DC**
13 W Class F (155°C)

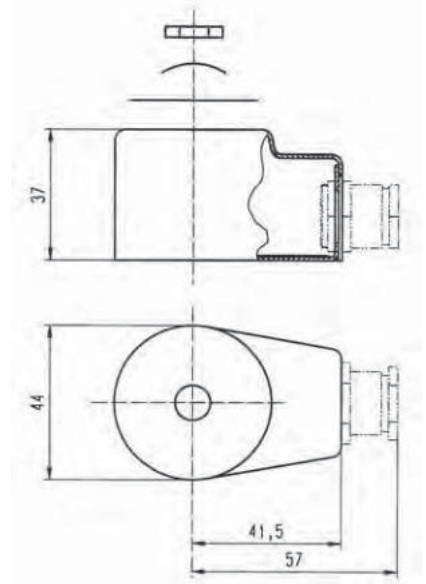

WATERPROOF AND DUSTPROOF HOUSING

Waterproof housing:

Reference:	4538
Material:	Epoxy varnished steel
Degree of protection:	IP according to IEC/EN 60529 IP 67 with cable gland
Electrical connection:	Cable connection by cable gland M20x1.5 according to DIN 46320. Cable with outer diameter 6.5 - 13.5 mm can be simply sealed using a rubber gland with resilient sealing rings. The enclosure is internally and externally fitted with grounding and earthing screw terminals.
Weight:	180 g



Benefits:

This enclosure is dust- and waterproof. It corresponds to the degree of "International Protection" IP 67 according to IEC / EN 60529. Corrosion resistant, the metal housing offers good protection for the coil against shocks and other outside influences - rotatable 360° - easy mounting in confined spaces - easy access to the screw terminals - single-nut mounting - light weight - simple conversion of existing electrical equipment to other requirements without interruption of fluid passage in the valve.

Application:

This housing can be equipped with several coils of our range, like the standard, double-frequency and magnetic latch coils.

Compatible coils:

- **481000 - Standard Coil**
8 W Class F (155°C)
- **483520 - Double-Frequency Coil**
9 W Class F (155°C)
- **484990 - Impulse Coil for AC**
11 W Class F (155°C)
- **485400 - Impulse Coil for DC**
13 W Class H (180°C)

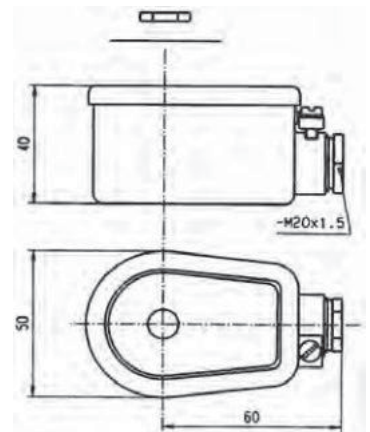

HOUSING

8520**WATERPROOF HOUSING
FOR HIGH-TEMPERATURE COILS****Waterproof housing:**

Reference:	8520
Material:	Epoxy varnished steel
Degree of protection:	IP according to IEC/EN 60529 IP 67 with cable gland
Electrical connection:	Cable connection by cable gland M20x1.5 according to European standards. Cable with outer diameter 6.5 - 13.5 mm can be simply sealed using a rubber gland with resilient sealing rings. The enclosure is internally and externally fitted with grounding and earthing screw terminals.
Weight:	180 g

**Benefits:**

This enclosure is dust- and waterproof. It corresponds to the degree of "International Protection" IP 67 according to IEC / EN 60529. Corrosion resistant, the metal housing offers good protection for the coil against shocks and other outside influences - rotatable 360° - easy mounting in confined spaces - easy access to the screw terminals - single-nut mounting - light weight - simple conversion of existing electrical equipment to other requirements without interruption of fluid passage in the valve.

Application:

The majority of the Parker Lucifer® valves can be fitted with this housing and can be mounted with several compatible Parker Lucifer® coils for high temperature (14 W, 8 W Class F or H).

Compatible coils:

- **481044 - High Power Coil**
14 W Class F (155°C)
- **486265 - High Power Coil**
14 W Class H (180°C)
- **485100 - Coil for High Temperature**
8 W Class H (180°C)

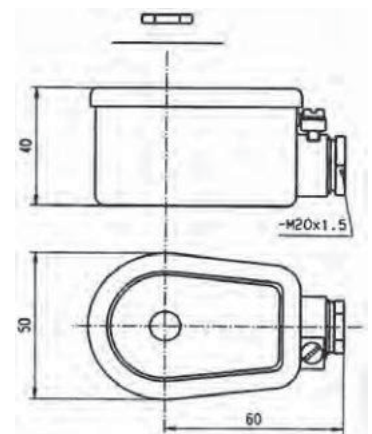

22 mm
32 mm

COIL ASSEMBLY KITS

COIL ASSEMBLY KIT FOR 22 mm COIL

The coil assembly kit corresponds to the numbering system for Parker Lucifer® valve housings (Valve - housing - coil/voltage).

It is composed of a nameplate with the details of the valve type, a washer and a nut to secure the 22 mm coil to the valve.

Caution: This coil assembly kits for 22 mm coils are not adapted for high flow valves, ask your distributor for the adapted kit.



KIT OF 100 PIECES

Reference	Specification	Application
488993.50	Standard - aluminium nameplate - passivated washer and nut - pressure indication in [bar]	Standard valves

COIL ASSEMBLY KIT FOR 32 mm COIL

The coil assembly kit corresponds to the "housing" of Parker Lucifer® valve numbering system (Valve - housing - coil/voltage).

It is composed of a nameplate giving details of the valve type, a round washer and a nut to ensure the fixing between 32 mm coil and the valve.



KIT OF 100 PIECES

Reference	Specification	Application
482995.50	Standard - Aluminium nameplate - Passivated iron washer and nut - Pressure indication in [bar]	Standards valves

ACCESSORIES

DIN PLUG CONNECTOR ACCORDING TO EN 175301-803 - B

No. 481043 for Parker Lucifer® coil
No. 600040 for Parker coil

Electrical connection suitable for all 22 mm coils
(e.g. 488980, 481180)



DIN PLUG CONNECTOR ACCORDING TO EN 175301-803 - A

No. 486586 for standard Parker Lucifer® version
No. 492645 for high temperature Parker Lucifer® version
No. 600004 for Parker version

Electrical connection suitable for all 32 mm coils
(e.g. 481865, 492425)



METALIC ASSEMBLY KIT

Nut No. 482213 M14 x 1+ Ring No. 482214 +
O-Ring No. 483917

Coil assembly kit for offshore electrical parts
(e.g. 482870.01, 492210, 492965.01, 496565, 496700)



PLASTIC NUT WITH METAL INSERT

No. 8886

For Oil & Gaz electrical parts
(e.g. 492965.01)



CABLE GLAND

No. 492398 - Pg 13.5 -Ex eb II
No. 493841 - M20x1.5 - Ex ia IIC

Electrical connection and mooring cable with 6 to 12 mm diameter, for electrical parts approved "eb mb" or "ia"
(e.g. 492190, 492965....)



CABLE GLAND

No. 493426 - 1/2"-14 NPT

Electrical connection and mooring cable with 6 to 12 mm diameter, for flameproof approved electrical parts
(e.g. 493640)





INTRODUCTION

Current European regulations concerning electrical equipment for potentially explosive environments are based on optional and partial European directives which require regular modification in the form of application or adaptation directives in order to keep pace with technical developments.

The basic European text in this field, directive **76/117/EC**, which allow the free circulation of goods within the European Union, provides the general framework for the present regulations.

Electrical equipment for use in potentially explosive environments is certified by a government-approved body when it meets relevant European standards (EN 60079-0 and upwards) covering each type of protection (**db, ia, eb, m, p**, etc). Such equipment is then issued with a **an EC type examination certificate**, entitling it to carry the distinctive marking.

This mark opens the way for trading within the European Union and occasionally beyond.

Although largely beneficial, it has revealed certain drawbacks, notably a lack of flexibility and the absence of a global concept for safety. It has now been completely revised by the **new European directive 94/9/EC from March 23, 1994**.

The EC type examination certificate to harmonised standards obtained in compliance with previous directives will remain valid until June 30, 2003, but their validity will cover only conformity to the harmonised standards specified in these directives.

EUROPEAN MEMBER COUNTRIES





DEFINITIONS

EXPLOSIVE ENVIRONMENTS

Mixture with air, under atmospheric conditions, of flammable substances in the form of gases, vapours, mists or dusts in which, after combustion has occurred, combustion spreads to the entire unburned mixture.

HAZARDOUS AREAS

A hazardous area is an area in which an explosive gas environment is present, or may be expected to be present, in quantities such as to require special precautions for construction, installation and use of electrical apparatus.

INGREDIENTS FOR AN EXPLOSION

- When combustible materials are mixed with air, an explosive mixture is produced. Danger of explosion therefore exists wherever these hazardous materials are handled: such a condition is to be found on the biggest chemical plant as well as at the smallest filling station.
- Nowadays with the use of electronic and electrical instrumentation in process control, the risk of combustion by electrical energy has increased sharply.
- To protect personnel and expensive equipment special precautions should be taken to prevent combustion of those dangerous substances. Conditions likely to ignite explosive mixtures are as follows:

Three conditions are enough to create an explosion.

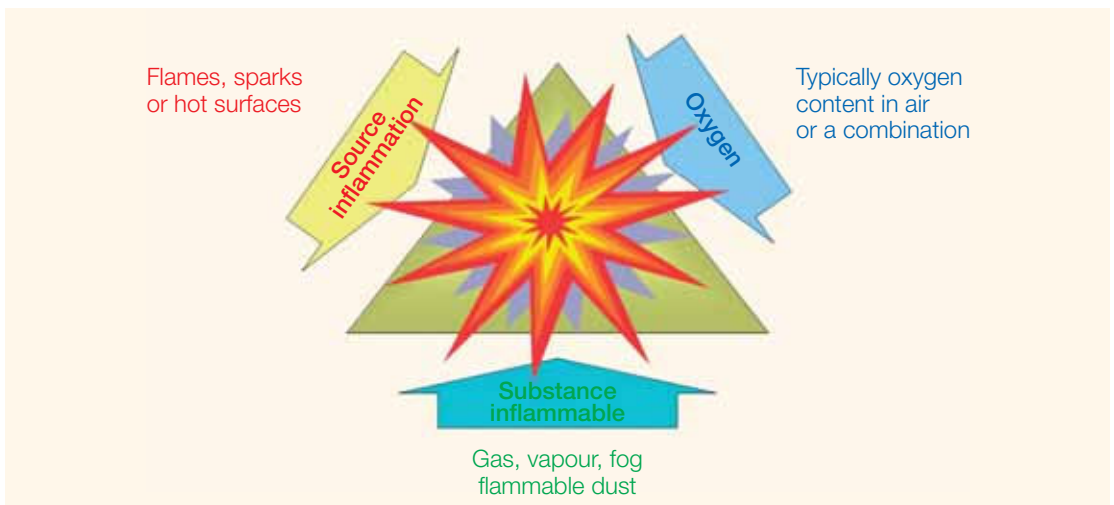



DEFINITIONS

ZONES

The hazardous areas are classified in zones based on the frequency of the occurrence and the duration of an explosive gas or dust environment as follows:

Zone 0 (20)	Zone 1 (21)	Zone 2 (22)
An area in which an explosive gas (dust) atmosphere is present CONTINUOUSLY or is present for LONG PERIODS (~1000 h/y).	An area in which an explosive gas (dust) atmosphere is present LIKELY TO OCCUR in normal operation (~10 to 999 h/y).	An area in which an explosive gas (dust) atmosphere is not LIKELY TO OCCUR and if it does occur it will exist for short period only (~1 to 10 h/y).
Mode of protection: ia - ma - px - ...	Mode of protection: db - eb - ib - mb - pxb - ...	Mode of protection: nc - mc - ic - pz - ...

HAZARDOUS LOCATION CLASSIFICATION

Explosive Environment	Continuous Presence	Intermittent Presence (normal operation conditions)	Occasional Presence (abnormal operation)
IEC	Zone 0 (gas) Zone 20 (dust)	Zone 1 (gas) Zone 21 (dust)	Zone 2 (gas) Zone 22 (dust)
Europe	Zone 0 (gas) Zone 20 (dust)	Zone 1 (gas) Zone 21 (dust)	Zone 2 (gas) Zone 22 (dust)
Canada (CEC)¹ USA (NEC)²	Cl. I Div. 1 (gas) Cl. II Div. 1 (dust) Cl. III Div. 1 (fibres)	Cl. I Div. 1 (gas) Cl. II Div. 1 (dust) Cl. III Div. 1 (fibres)	Cl. I Div. 2 (gas) Cl. II Div. 2 (dust) Cl. III Div. 2 (fibres)

¹ (CEC): Code Canadien d'Electricité / ² (NEC): National Electrical Code

Example:

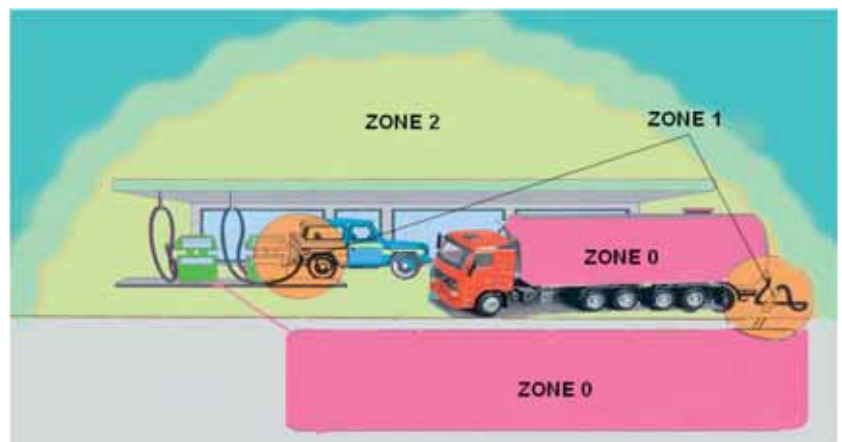



DEFINITIONS

HAZARDOUS LOCATION CLASSIFICATION

Category	Fault protection	Atmosphere	Zone	Example of protections
----------	------------------	------------	------	------------------------

EC Type examination by Notified Body → annex III

1 Very high level	2 types of protection or 2 independant faults	G (Gas)	0	"ia", "ma", "px" or "ia-ma", "db/eb"
		D (Dust)	20	

EC Type examination by Notified Body → annex III

2 High level	One type of protection Habitual frequent malfunction	G (Gas)	1	One type of protection lb, db, mb, eb, py, o,...
		D (Dust)	21	

Internal production inspection → EC declaration of conformity

3 Normal	Required level of protection	G (Gas)	2	n, ic, pz, ... A, C, L, P, R
		D (Dust)	22	

Hazardous Location Classification

Group	Gas Reference
I	Methane
IIA	Propane
IIB	Ethylene
IIC	Hydrogen / Acetylene

Group	Dust Reference
-	-
IIIA	Fibres
IIIB	Non-conductive dust
IIIC	Conductive dust

Surface Temperature Classes

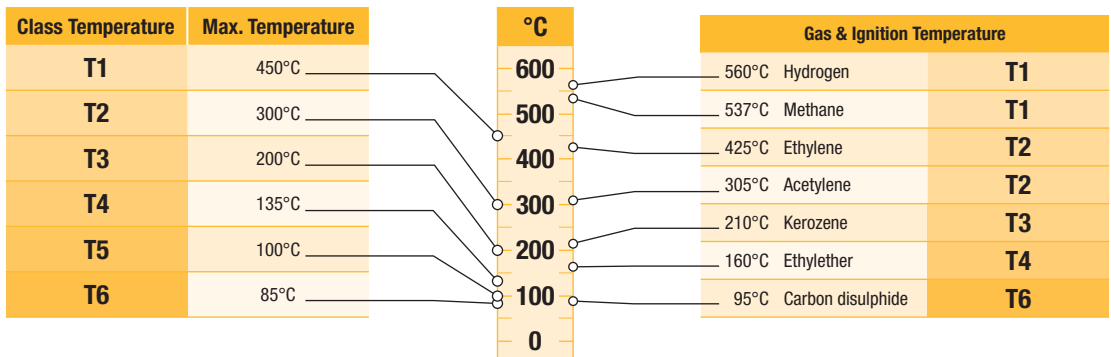



PROTECTION MODES

PROTECTION MODES

Concept	Code		Zones	
	Gas	Dust	Gas	Dust
Flameproof enclosure	db	tb	1/2	21/22
Encapsulation	ma / mb / mc	tb / tc	0/1/2	20/21/22
Increased Safety	eb	-	1/2	-
Intrinsic Safety	ia / ib / ic	ta / tb / tc	0/1/2	20/21/22
Pressurized apparatus	pxb / py / pz	pD	1/2	21/22
Concept Cat. 3 apparatus	nA	-	2	-
	nL	-	2	-
	nR	-	2	-
	nC	-	2	-

In red, protection modes used by parker FCDE.



STANDARDS AND PROTECTION MODES

APPARATUS FOR EXPLOSIVE GAS ATMOSPHERES EQUIPMENT GROUP II

EPL	Standards EN / IEC	Protection	Title
	60079-0	-	General requirements
Ga	60079-11	ia	Intrinsic safety
	60079-18	ma	Encapsulation
	60079-26		Equipment with equipment protection level (EPL) Ga (Zone 0)
	60079-28	op is	Protection of equipment and transmission systems using optical radiation
Gb	60079-1	db	Flameproof enclosures
	60079-2	p, pxb, py	Pressurized enclosures
	60079-5	q	Powder filling
	60079-6	o	Oil immersion
	60079-7	eb	Increased safety
	60079-11	ib	Intrinsic safety
	60079-18	mb	Encapsulation
	60079-25		Intrinsically safe systems
	60079-27		Fieldbus intrinsically safe concept (FISCO)
	60079-28	op is op pr op sh	Protection of equipment and transmission systems using optical radiation
Gc	60079-11	ic	Intrinsic safety
	60079-18	mc	Encapsulation
	60079-15	nA	Non sparking
	60079-15	nR	Restricted breathing enclosure
	60079-15	nL	Limited energy (only old edition)
	60079-15	nC	Equipment producing operational sparks
	60079-2	pz	Pressurized enclosures
	60079-27		Concept de réseau de terrain de sécurité intrinsèque (FISCO)
	60079-28	op is op pr op sh	Protection of equipment and transmission systems using optical radiation

EPL = Equipement Protection Level

In red, protection modes used by parker FCDE.



STANDARDS AND PROTECTION MODES

ELECTRICAL EQUIPMENT FOR USE IN AREAS WITH COMBUSTIBLE DUST - EQUIPMENT GROUP III

EPL	Standards EN / IEC	Protection	Title
	60079-0	-	General requirements
Da	60079-31	ta	Protection by enclosure
	60079-11	ia	Protection by intrinsic safety (iaD IEC/EN 61241-11)
	61241-18	ma	Protection by encapsulation
Db	60079-31	tb	Protection by enclosure
	60079-11	ib	Protection by intrinsic safety (ibD IEC/EN 61241-11)
	60079-18	mb	Protection by encapsulation
	IEC 61241-4	pD	Type of protection "pD"
Dc	60079-31	tc	Protection by enclosure
	60079-11	ic	Protection by intrinsic safety
	60079-18	mc	Protection by encapsulation
	IEC 61241-4	pD	Type of protection "pD"

EPL = Equipement Protection Level

In red, protection modes used by parker FCDE.

NON ELECTRICAL EQUIPMENT FOR USE IN POTENTIALLY EXPLOSIVE ATMOSPHERE

Standards	Protection	Title
EN 13463-1	-	Basic method and requirements
EN 13463-2	fr	Protection by flow restricting enclosure
EN 13463-3	db	Protection by flameproof enclosure
EN 13463-5	c	Protection by constructional safety
EN 13463-6	b	Protection by control of ignition source
EN 13463-7	p	Protection by pressurized enclosure
EN 13463-8	k	Protection by liquid immersion

ZONES AND EQUIPEMENT PROTECTION LEVEL (EPL)

Zone	Gas	EPL	Zone	Dust	EPL
0		Ga	20		Da
1		Ga and Gb	21		Da and Db
2		Ga, Gb and Gc	22		Da, Db and Dc

CATEGORIES AND EQUIPEMENT PROTECTION LEVEL (EPL)

Categories	Gas	Dust	Safety
1	Ga	Da	Very high
2	Gb	Db	High
3	Gc	Dc	Normal



EXAMPLES OF MARKING

ELECTRICAL APPARATUS FOR EXPLOSIVE GAS ATMOSPHERES EQUIPMENT GROUP II

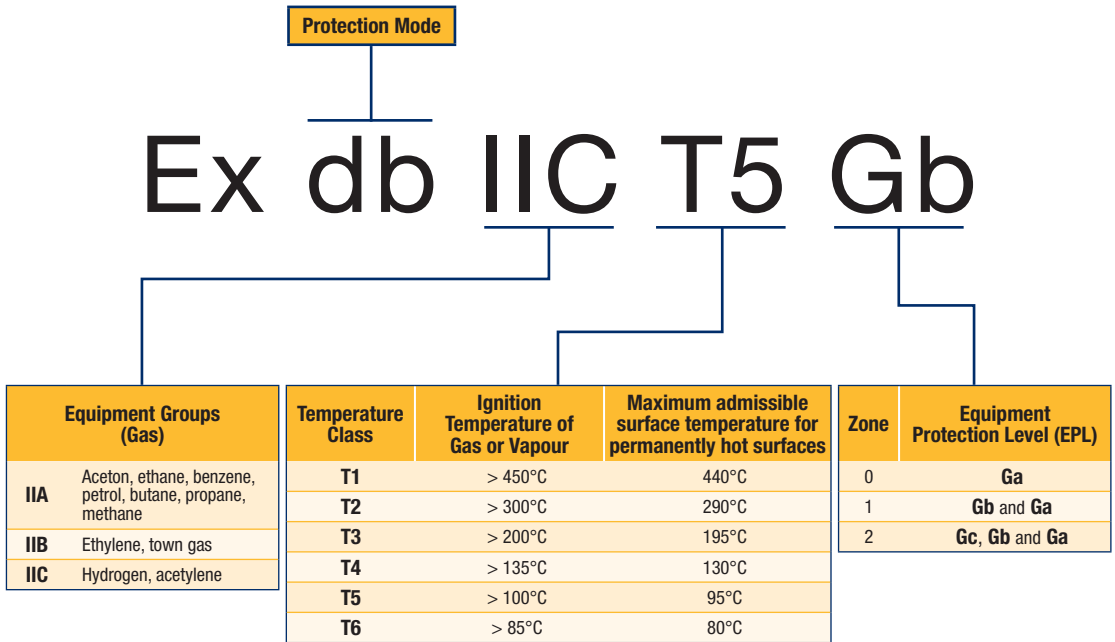

ELECTRICAL EQUIPMENT FOR USE IN AREAS WITH COMBUSTIBLE DUST - EQUIPMENT GROUP III

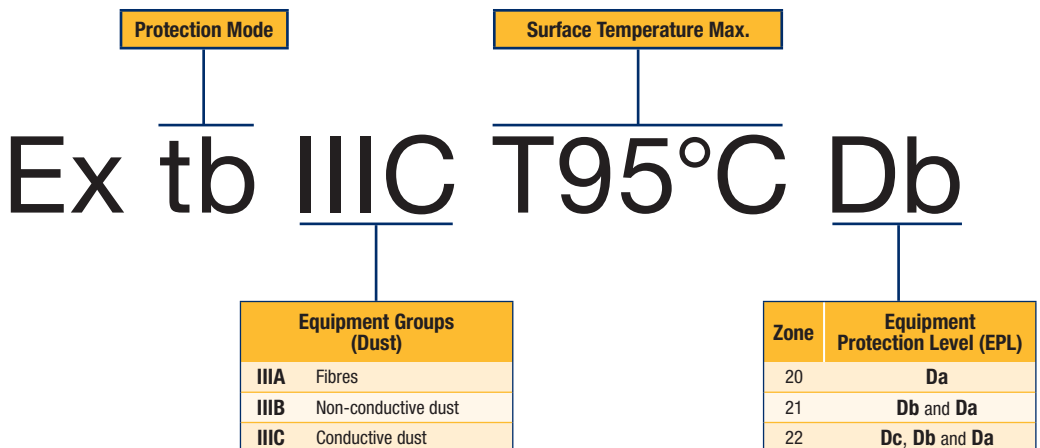



WHAT ABOUT THE DIRECTIVE ? (94/9/EC - 1994-03-23)

WHAT ABOUT THE DIRECTIVE ? (94/9/EC - 1994-03-23)

In keeping with the "**new approach**", the new directive lays down the framework for a total harmonization of regulations covering this field.

It makes no direct references to standards but sets out the essential health and safety requirements to be met and introduces the **CE** marking.

ATEX 100 A DIRECTIVE - NEW APPROACH

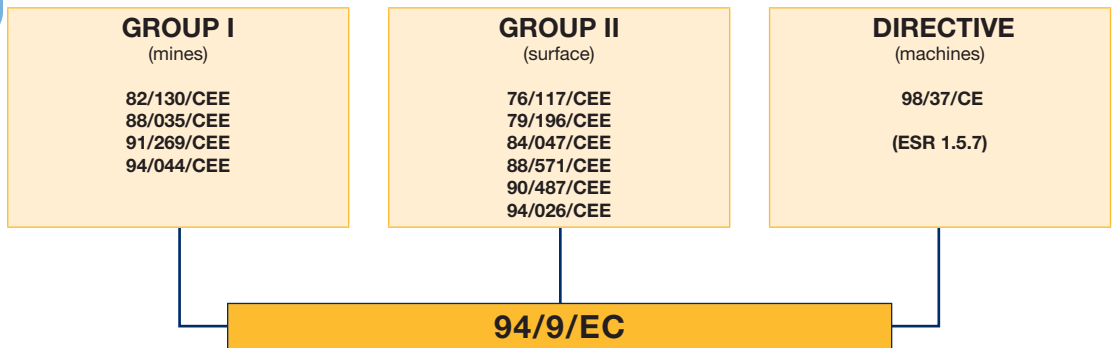

THE FRAMEWORK OF THE DIRECTIVE

The main principles of the new directive can be summarized as follows:

- It applies to **electric** and **non-electric** equipment.
- It defines **essential health and safety requirements**.
- It takes into consideration **all potential hazards** equipment may cause, in particular at design and production level.
- **The one directive** applies to both **mines** susceptible to fire damp and **surface industries**.
- It stresses the importance of equipment being **used in accordance with its intended purpose**.
- It recognises The European Standards Committee **CEN** and the European Committee for Electrotechnical Standardisation **CENELEC** as competent bodies to fix the required harmonised standards.
- It provides for the **contribution of labour and management**.
- It defines **procedures for assessing conformity** to essential requirements, on the basis of modules which qualify equipment to carry the **CE** mark of conformity.

APPLICATIONS

The directive applies to the industrial field and concerns the following equipment:

- **Equipment** (machines, apparatus, etc.)
- **Protective systems** (discharge devices, explosion suppression devices, etc.)
- **Components** (parts with no autonomous function, terminals, etc.)
- **Safety devices, controlling devices and regulating devices** intended for use outside potentially explosive environments but required for safety with respect to explosions (relays, barriers, pressure switches, thermostats, etc.)



WHAT ABOUT THE DIRECTIVE ? (94/9/EC - 1994-03-23)

EXCLUDED FROM THE SCOPE OF THE NEW DIRECTIVE

The following equipment falls outside the scope of the new directive:

- Medical devices intended for use in a medical environment.
- Equipment and protective systems relating only to the risk of explosion of unstable chemical substances (explosives, etc.)
- Equipment intended for use in domestic and non-commercial environments.
- Personal protective equipment covered by directive 89/686/EC.
- Seagoing vessels and mobile offshore units.
- Means of transport, except for vehicles intended for use in a potentially explosive environment.

APPLICATION DATES

ATEX 100A DIRECTIVE - NEW APPROACH

94/9/EC

Application dates

• Transposition to national law	1/9/1995
• Application (optional)	1/3/1996
• Application (total)	1/7/2003

POTENTIAL IGNITION SOURCES AND OTHER HAZARDS TO BE CONTROLLED

The following all represent potential hazards:

- Various sources of ignition, such as sparks, flames, electric arcs, high surface temperature, acoustic energy, optical radiation or electromagnetic waves.
- Static electricity.
- Pressure compensation operations.
- Disturbance from external sources, such as changing environmental conditions, extraneous voltage, humidity, vibration or contamination.

Provision is also made for specific requirements governing devices used to provide additional equipment safety.

These requirements necessitate detailed analysis to assess the operational reliability of such devices and their interaction with other components connected with the equipment.



GUIDANCE CHART FOR IS-BARRIERS

Manufacturer	Reference	Ex	IS Standard Electrical Parts							IS Booster Electrical Parts				
			Ex ia IIC T6 488650.01/02 488660.01 LCIE/AUS	Ex ia IIC T6 490885 490890 (490895) LCIE/FM/CSA	Ex ia IIC T6 483580.01/03 483960.01/03 LCIE/AUS	Ex ia 490880 (493997) LCIE/FM/CSA	Ex ia IIB T6 482160.01 LCIE	Ex ia IIC T6 482870.01 LCIE	Ex ia 492335 LCIE/FM/CSA	Ex ia IIC T6 492965.01/02 LCIE	Ex ia IIC T6 496565 LCIE	Ex ia IIC T6 495910 LCIE		
A puissance 3	NAEV 22-140	ia	●	-	●	-	●	●	-	●	●	●		
	NAEV 26-100	ia	●	-	●	-	●	●	-	●	●	●		
ABB	V171132-54	ib	●	-	●	-	●	●	-	●	●	●		
	V171132-55	ib	●	-	-	-	●	●	-	●	●	●		
	V171132-61	ia	●	-	-	-	●	●	-	●	●	●		
	DO 890	ib	●	-	●	-	●	●	-	●	●	●		
	S900-D04-EX	ib	●	-	-	-	●	●	-	●	●	●		
BRADLEY	FEX-EX 24V	ia	●	●	●	●	●	●	-	●	●	●		
COOPER	LB 2101	ia	●	●	●	●	●	●	●	●	●	●		
	LB 2105	ia	●	●	●	●	●	●	●	●	●	●		
	LB 2112	ia	●	●	●	●	●	●	●	●	●	●		
ELCON	1881 / 1882	ia	●	●	●	●	●	●	●	●	●	●		
	471 / 472	ia	●	●	●	●	●	●	●	●	●	●		
	2871/2872	ia	●	●	●	●	●	●	●	●	●	●		
	2874/2875/2876	ia	●	●	●	●	●	●	●	●	●	●		
GEORGIN	AVB 122	ia	●	-	●	-	●	●	-	●	●	●		
	AVB 125	ia	●	-	-	-	●	●	-	●	●	●		
	AVB 128	ia	●	-	●	-	●	●	-	●	●	●		
Hima	F3328A	ib	●	-	-	-	●	●	-	●	●	●		
	F3335	ib	●	-	-	-	●	●	-	●	●	●		
	H4007	ib	●	-	●	-	●	●	-	●	●	●		
MTL	728P, 7128P, 7728P	ia	-	-	-	-	●	●	-	-	●	●	●	
	728, 7028, 7128, 7728	ia	●	●	●	●	●	●	●	●	●	●	●	
	3021, 4021, 4021S	ia	●	-	●	-	●	●	-	●	●	●	●	
	3022	ia	-	-	-	-	●	-	-	-	-	-	-	
	4023	ia	-	-	-	-	●	-	-	-	-	-	-	
	4024	ia	●	-	●	-	●	●	-	●	●	●	●	
	4025	ia	●	●	●	●	●	●	●	●	●	●	●	
	5021, 5023, 5024	ia	●	-	●	-	●	●	-	●	●	●	●	
	5025	ia	●	-	●	-	●	●	●	●	●	●	●	
	4521 / 4523 / 4524	ia	●	-	-	-	●	●	●	●	●	●	●	
	5521 / 5523 / 5524	ia	●	-	-	-	●	●	●	●	●	●	●	
	Pepperl & Fuchs	Z 728	ia	●	●	●	●	●	●	●	●	●	●	●
		Z 779	ia	●	●	●	●	●	●	●	●	●	●	●
		EGA-041-3	ia	-	●	●	●	●	●	●	●	●	●	●
KFD2-SD-EX1.36		ia	-	-	-	-	-	●	-	-	-	-	-	
KFD2-SL-EX1.36		ia	-	-	-	-	-	●	-	-	-	-	-	
KFD2-SD-EX1.48		ia	-	●	-	●	-	-	●	●	●	●	●	
KFD2-SL-EX1.48		ia	-	●	-	●	-	-	●	●	●	●	●	
KFD2-SL- EX1.48.90A		ia	-	-	-	-	-	-	-	●	●	●	●	
KFD2-SL- EX1.48.90A		ia	-	-	-	-	-	-	-	●	●	●	●	
KFD2-SL2-EX1.LK		ia	-	●	-	●	-	-	●	●	●	●	●	
KFD2-SL2-EX2		ia	-	●	-	●	-	-	●	●	●	●	●	
KSD2-B0-EX		ia	-	●	●	●	●	●	●	●	●	●	●	
RSD-B0-EX4		ib	-	-	-	-	-	-	●	●	●	●	●	
RSD-V0-EX8		ib	-	-	-	-	-	-	-	●	●	●	●	



GUIDANCE CHART FOR IS-BARRIERS

Manufacturer	Reference	Ex	IS Standard Electrical Parts						IS Booster Electrical Parts			
			Ex ia IIC T6 488650.01/02 488660.01 488670.01 LCIE/AUS	Ex ia IIC T6 490885 490890 (490895) LCIE/FM/CSA	Ex ia IIC T6 483580.01/03 483960.01/03 LCIE/AUS	Ex ia 490880 (493997) LCIE/FM/CSA	Ex ia IIB T6 482160.01 LCIE	Ex ia IIC T6 482870.01 LCIE	Ex ia 492335 LCIE/FM/CSA	Ex ia IIC T6 492965.01/02 LCIE	Ex ia IIC T6 496565 LCIE	Ex ia IIC T6 495910 LCIE
SIEMENS	5RD00-0AB0	ib	-	-	-	-	-	-	-	●	-	-
	7RD00-0AB0	ia	-	-	-	-	-	-	-	●	●	●
	7RD01-0AB0	ia	-	-	-	-	-	-	-	●	●	●
	7RD10-0AB0	ia	-	-	-	-	-	-	-	●	●	●
	7RD11-0AB0	ia	-	-	-	-	-	-	-	●	●	●
	7RD20-0AB0	ia	-	-	-	-	-	-	-	●	●	●
	7RD21-0AB0	ia	-	-	-	-	-	-	-	●	●	●
STAHL	9001/01-252-100-14	ia	●	●	27 V	27 V	●	●	●	●	●	●
	9001/01-280-100-10	ia	●	●	24 V	24 V	●	●	●	●	●	●
	9001/01-280-110-10	ia	●	-	24 V	-	●	●	-	●	●	●
	9002/13-280-100-04	ia	24 V	24 V	27 V	27 V	24 V	24 V	24 V	17 V	17 V	17 V
	9311/52-11-10	ia	-	●	●	25 V	25 V	●	●	15 V	15 V	15 V
	9111/63-11-00	ia	-	●	●	25 V	25 V	●	●	15 V	15 V	15 V
	9351/10-15-10	ia	-	●	●	-	-	●	●	●	●	●
	9351/10-16-10	ia	-	●	●	●	-	●	●	●	●	●
	9351/10-17-10	ia	-	-	-	-	-	●	-	-	-	-
	9381/10-187-050-10	ib	-	●	●	●	●	●	●	●	●	●
	9381/10-246-055-10	ib	-	●	●	●	●	●	●	●	●	●
	9381/10-246-070-10	ib	-	●	●	●	●	●	●	●	●	●
	9465/12-04-11	ib	-	●	●	-	-	●	●	●	●	●
	9475/12-04-21	ia/ib	-	●	-	●	-	●	●	●	●	●
	9475/12-04-31	ia/ib	-	-	-	-	-	-	-	●	●	●
	9475/12-08-41	ia/ib	-	-	-	-	-	-	-	-	-	-
	9475/12-08-51	ib	-	-	-	-	-	-	-	●	●	●
	9475/12-08-61	ia/ib	-	-	-	-	-	-	-	-	●	●
	Turck	MK72-S01-EX	ib	-	-	-	-	●	●	-	●	●
MK72-S02-EEX		ib	-	-	-	-	●	●	-	●	●	●
MK72-S04-EEX		ib	●	-	●	-	●	●	-	●	●	●
MK72-S05-EEX		ib	●	-	-	-	●	●	-	●	●	●
MK72-S06-EEX		ib	●	-	●	-	●	●	-	●	●	●
MK72-S07-EEX		ib	●	-	-	-	●	●	-	●	●	●
MK72-S09-EEX		ia	-	-	-	-	-	-	-	-	-	-
MK72-S12-EEX		ia	●	-	●	-	●	●	-	●	●	●
MC72 - 41		ia	●	-	●	-	●	●	-	●	●	●
MC72 - 43	ia	●	-	●	-	●	●	-	●	●	●	
MC72 - 44	ia	-	-	-	-	-	-	-	●	●	●	
BARTEC	07-7331-2301/1000	ia	●	-	-	-	●	●	-	●	-	-
	07-7331-2301/1100	ia	●	-	●	-	●	●	-	●	-	-

If barrier reference not listed, consult factory for compatibility (tech.support@parker.com)

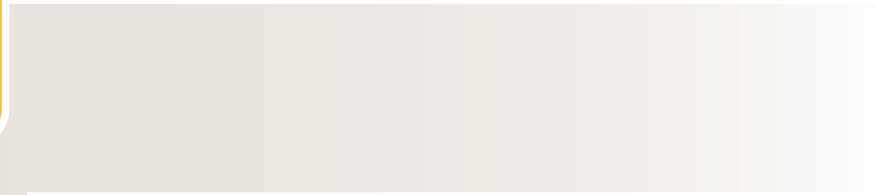

TECHNICAL INFORMATION ABOUT SOLENOID VALVES

TECHNICAL INFORMATION ABOUT SOLENOID VALVES

General Information

Solenoid valves are electro-mechanical devices used for interrupting or diverting the flow of fluids by opening or closing one or more orifices.

The solenoid valve is a combination of three basic components:

1. An electromagnet consisting of a solenoid (windings) and a magnetic yoke.
2. A pilot with a moveable plunger (which, in some cases directly opens and closes the valve).
3. A valve body with an orifice opened or closed by plunger or diaphragm to enable or prevent flow of the medium.

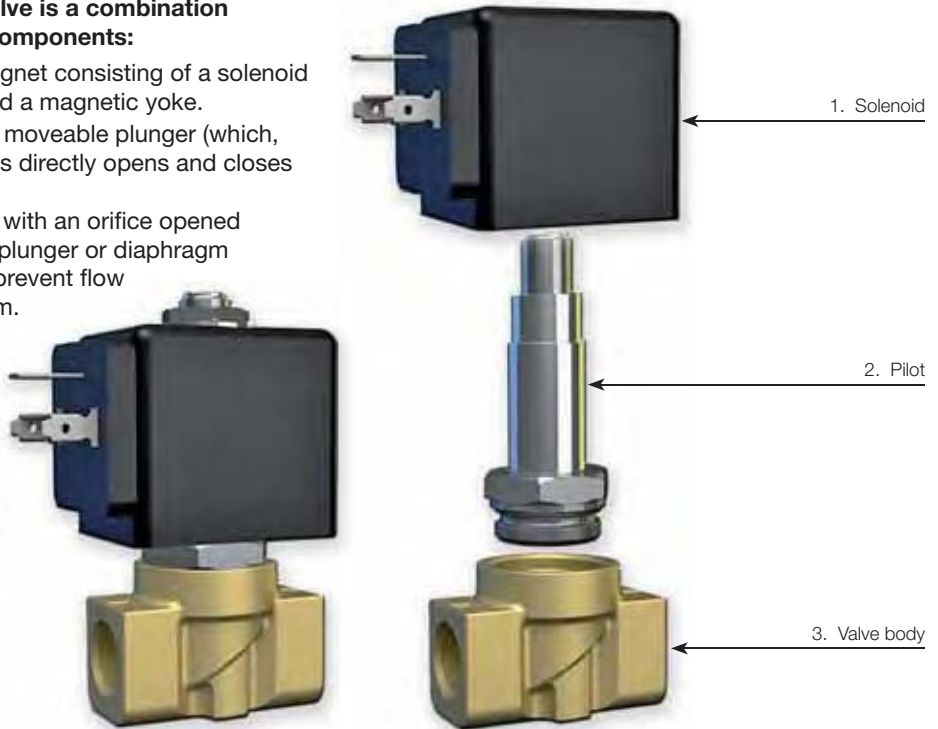

Operating principles

The term solenoid refers to operator and coil, also known as pilot or magnetic actuator.

The coil consists of copper wire wound on a support reel. When electric current is applied into the coil, magnetic flow lines are generated which are stronger in the coil center.

This magnetic flow raises the moveable plunger in the coil until it brings it into contact with the pole piece. The valve body has an orifice through which the fluid flows when the valve is open.

The moveable plunger has an integral seat which when the solenoid coil is energised, moves off the valve (direct operated) orifice or diaphragm (pilot operated) orifice opening the valve.

When the coil is de-energised, a return spring brings the plunger back to the original closing position, thus cutting off the flow of the fluid.

BASIC COMPONENTS OF A SOLENOID VALVE

- Valve body:** Main part of the solenoid valve including ports, seat and orifices.
- Solenoid tube assembly:** Cylinder, in stainless steel, hermetically sealed and closed at one extremity. It is the guide channel of the moveable plunger which is moved magnetically. The solenoid coil is fitted on the external side of the enclosing tube.
- Moveable plunger:** Made by ferritic stainless steel, it is attracted by the solenoid magnetic field and slides inside the tube.
- Plunger spring (or return spring):** Used to hold the moveable plunger in position and to return it when de-energized.
- Seat seal:** Part of the moveable plunger, it is used to close a valves main orifice or pilot orifice.
- Electromagnet (or solenoid coil):** Electrical part consisting of a copper windings (solenoid) along, with a magnetic yoke (armature), when electric current flows through, it generates a magnetic field attracting the moveable plunger.
- Housing:** Part that contains and protects the coil.
- Yoke:** Metallic case surrounding the coil and concentrating electro-magnetic force on the moveable plunger.

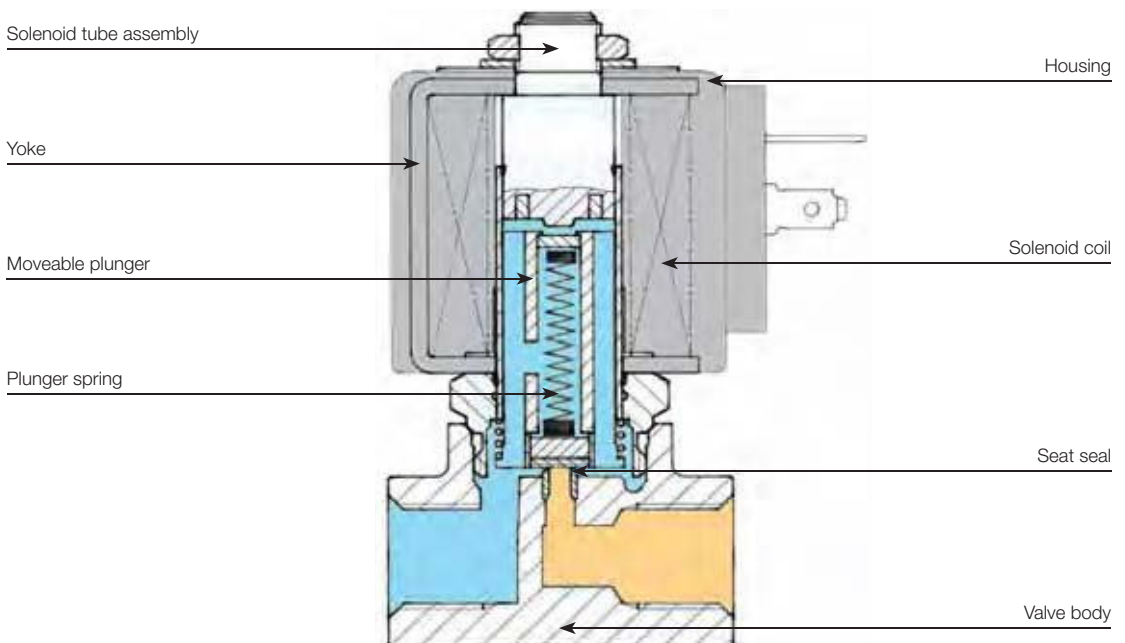

TECHNICAL VOCABULARY USED IN TABLES

Actuation	Body	Function	Port Size	Orifice (mm)	Flow Factor Kv(l/min)	MOPD (bar)	Max Fluid Temp. (°C)	Page Parker Valves	Page Parker LUCIFER® Valves
-----------	------	----------	-----------	--------------	-----------------------	------------	----------------------	--------------------	-----------------------------

NORMALLY CLOSED

Port size	Orifice Ø	Flow factors			Operating Pressure Differential			Fluid Temp.		Seat Seal	Parker LUCIFER® Valves			Power		Coil Group	Dwg. No.
		Kv l/min	KV m³/h	Qn l/min	Min bar	Max(MOPD) AC bar	DC bar	Min °C	Max °C		Valve Ref.	Housing Ref.	Coil Ref.	AC W	DC W		
BSP	mm																

The basic technical features of each solenoid valve are indicated in the tables, the terminology used is shown and explained below. Please notice that in certain sections you will have the choice between two product ranges: Parker valves, within blue tables and the Parker Lucifer valves, within orange tables.

- Actuation:** The mechanical method used to control the flow.
- Body:** Main part of the solenoid valve with the ports, seats and orifice needed.
- Function:** The way the valve operates when de-energised.
- Port Size:** Fitting dimensions are defined as threaded in inches (G), in BSP or Sub-base, when a flat interface for ports is adopted.
- Orifice (mm):** Main orifice diameter in millimetres (nominal diameter).
- Flow Factors:** Define the quantity of water which flows through the solenoid valve with a pressure drop of 1 bar during one minute. Expressed in l/min and m³/h.
- Max Fluid Temperature:** Maximum fluid temperature the valve can withstand.
- Max Ambient Temperature:** Maximum ambient temperature the valve can withstand.
- Minimum Operating Pressure Differential:** The lowest differential pressure required for operation (bar).
- Maximum Operating Pressure Differential (MOPD):** The highest working differential pressure with 90% of the rated voltage (-10% Vn) applied to the solenoid coil (for AC) and 95% of the rated voltage (-5% Vn)(for DC).

NORMALLY CLOSED

Port size	Orifice Ø	Flow factors			Operating Pressure Differential			Fluid Temp.		Seat Seal	Parker Valves			Power		Coil Group	Dwg. No.
		Kv	KV	Qn	Min	Max(MOPD)		Min	Max		Valve Order Number	Valve Type	Coil Type	AC	DC		
BSP	mm	l/min	m ³ /h	m ³ /h	bar	AC bar	DC bar	°C	°C				W	W			

Fluid Temperature:	Minimum and Maximum admissible temperature for the media used (°C).
Seat seal:	Material used for the seat discs.
Valve order number:	Applicable for Parker Valves shown in blue tables. The valve order number refers to the valves only. (please refer to the "How To Order" section for more details).
Valve ref.:	Applicable for Parker Lucifer Valves shown in orange tables. The valve ref. refers to the valve. (please refer to the "How To Order" section for more details).
Valve type:	Refers to the Parker valve type
Housing ref.:	Only for Parker Lucifer valves shown in orange tables, you can choose the housing to protect the coil.
Coil Ref.:	Compatible coil reference.
Coil type:	Compatible coil advised.
Power:	Power consumption of a specific electrical part on selected pressure vessel, rated by AC and DC (W). Power consumption must be considered in cold conditions for the coil, at T _{Amb} : +20°C. For 483510, 481865 and 496081 series, power consumption indicated in the tables must be considered in warm conditions.
Coil group:	Please refer to the specific section for the coil compatibility groups.
Dwg. No.:	Drawing number.

TECHNICAL INFORMATION

Solenoid valves are highly engineered products that can be used in many diverse applications.

In addition to operational functionality, media compatibility and suitability for the operating environment when selecting the best product for a given application.

This section provides a brief overview of the components, actuation and function modes of solenoid valves available from Parker Hannifin - FCDE.

Different Technologies:

Solenoid valves are electrically operated devices used to control flow. The most common types of solenoid valve are:



**Direct Operated
Valves**



Magnalift Valves



**Pilot Operated
Valves**

DIRECT OPERATED VALVE

Magnetic force is used directly to open or close the plunger which controls the passage of the fluid. Performances are limited by the coil, the pressure, and the valve orifice size. For direct operated valves, the minimum working pressure is 0 bar and the maximum pressure relies on the combination (valve/coil) chosen.

Direct Operated Valve

De-energised

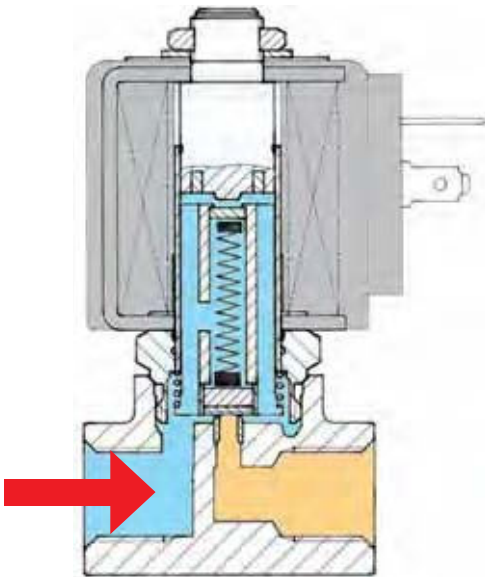

Energised

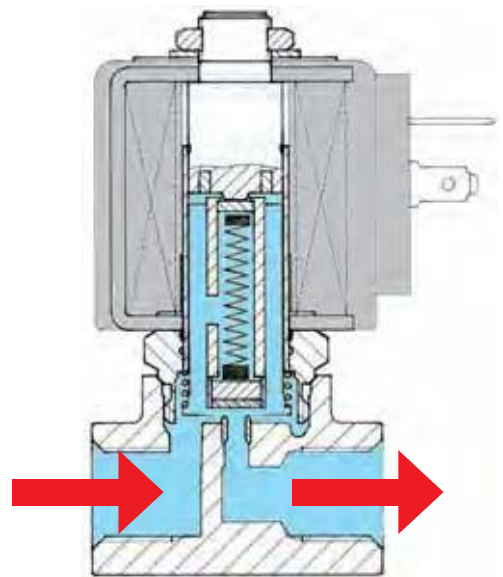

Example:

- 121 Series
- 146 Series
- N74 Series

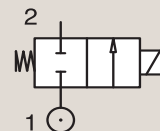

PILOT OPERATED VALVE

To control a higher flow, it is necessary to use pilot operated valves. The supply pressure enters the direct operated "pilot stage" which directs the flow to a "pilot chamber" which, in turn, applies the pilot pressure over a large area (generally a diaphragm or piston). Therefore, a large force is generated to move the main sealing elements against higher pressure or over a large orifice. One condition of operation is to have a minimum pressure available to shift the valve (indicated in the catalogue). In most applications, this presents no particular problems (refer to magnalift valve section). The pressure rating of the valve starts between 0.1 to 0.5 bar (depending on the valve). (NB. Pilot Operated Valves are also called Servo Operated Valves).

Pilot Operated Valve

De-energised

Energised

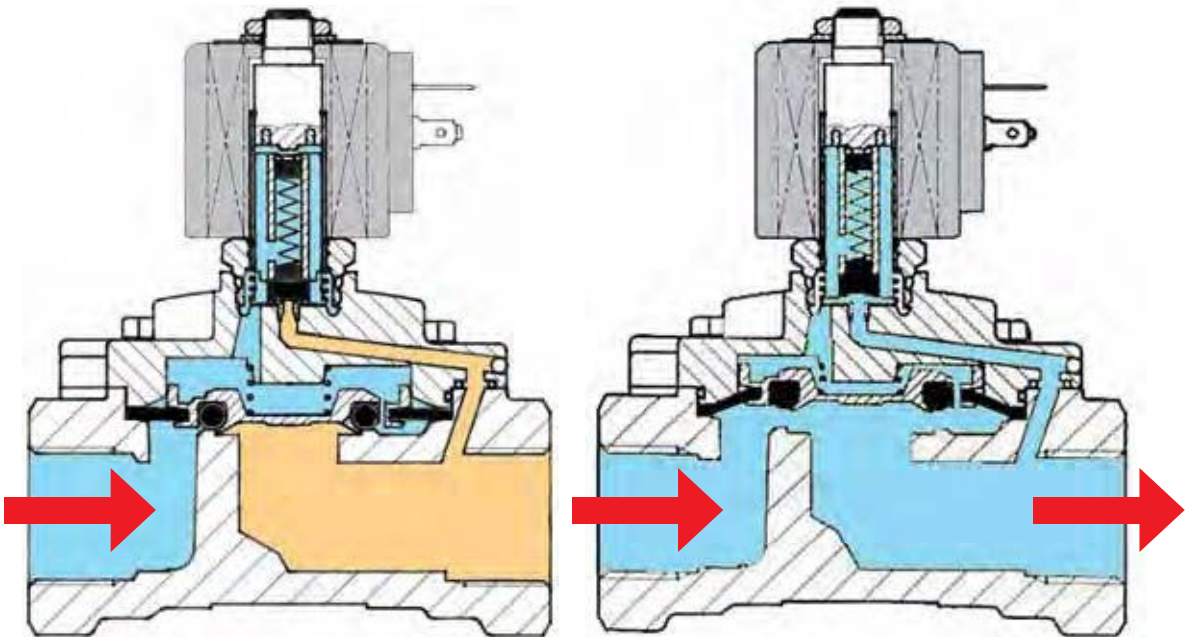

Example:

- 321 Series
- 7321B Series
- 168.1 Series

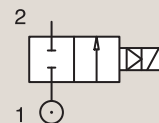

MAGNALIFT VALVE

The magnalift valves combine the features of the direct operated and pilot operated valves. A mechanical link between the plunger and diaphragm retainer allows the valve to operate as a direct operated valve at low pressures and as a pilot operated valve at higher pressures. Magnalift valves are specially designed for applications where 0 pressure is needed to operate the valve, as well as bigger flow than a direct operated valve.

Magnalift Operated Valve

De-energised

Energised

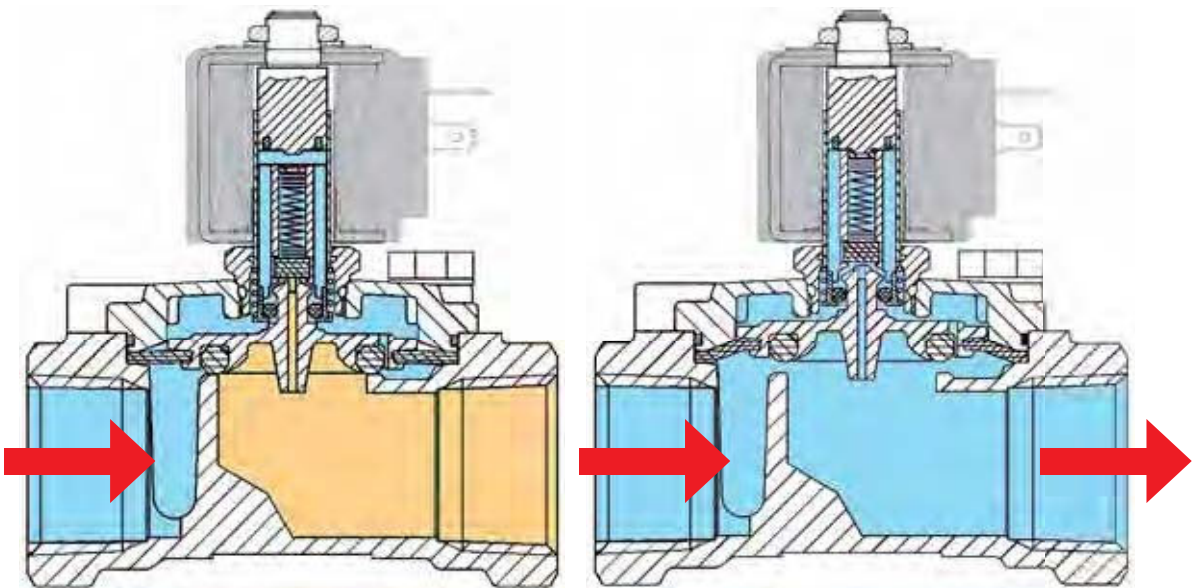

Example:

- 221 Series
- 123 Series

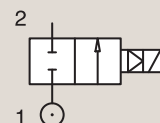

NORMALLY CLOSED VALVE

Most of our valves are available in normally closed and normally open configuration when not energized. In certain applications, you may require a normally open valve (open function in case of current failure). The differentiating factor of design of this technology, is based upon the design of the seat seal, which is reversed in comparison to a normally closed valve.

Normally Closed Valve

De-energised

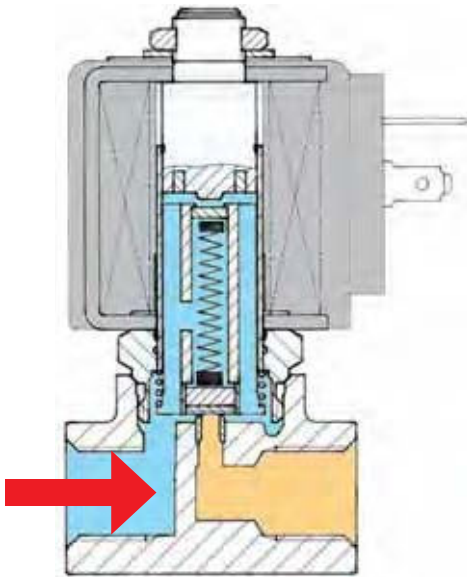

Energised

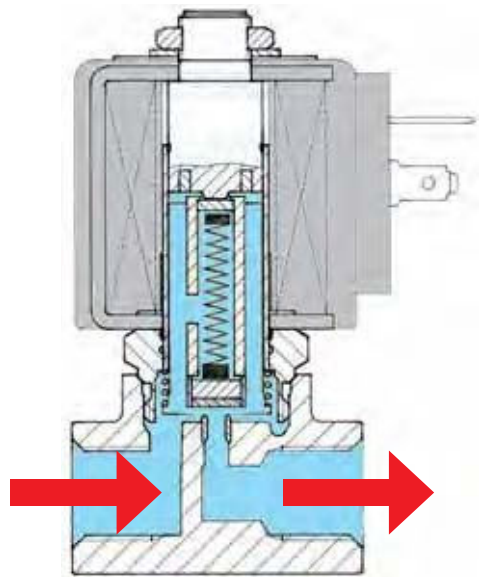

Example:

- 121 Series
- 146 Series
- N74 Series

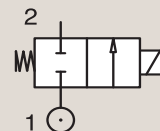

NORMALLY OPEN VALVE

Normally Open Valve

De-energised

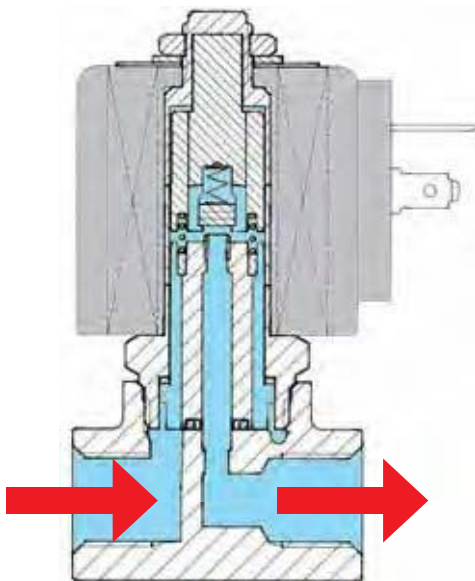

Energised

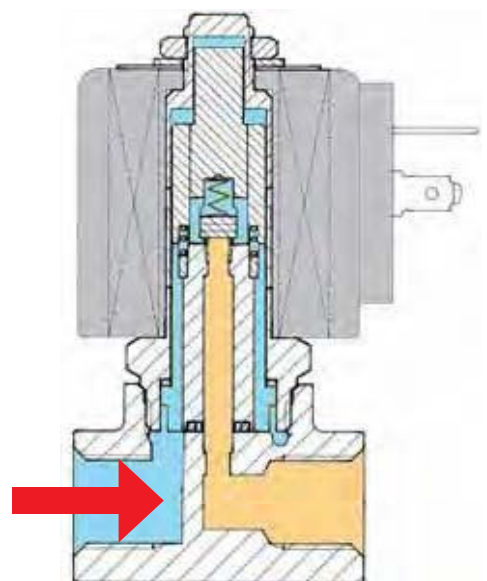

Example:

- 122 Series
- 136 Series
- 7322B Series

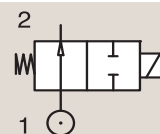

FLOW AND PRESSURE RANGES

Area of operation:

Each valve principle, as described in the previous pages, has a defined area of operation related to its pressure and flow capabilities. The following graph shows which type of valve is suitable for a certain situation.

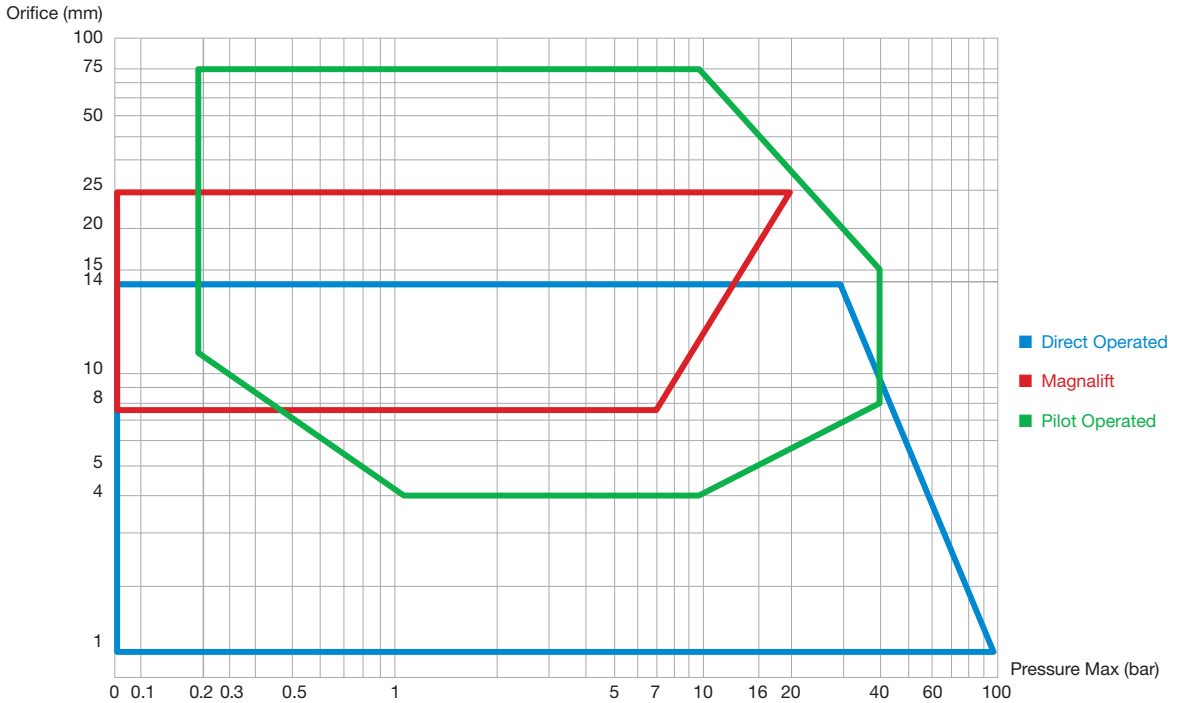

Areas of operation of Parker solenoid valves.

SIZING SOLENOID VALVES

The correct choice of solenoid valve is essential as it determines the regulation and performance required for practical application on a system. In order to decide on the exact type of solenoid valve, various parameters have to be known.

However the calculation method, based on the flow coefficient K_v , has proved highly practical as it can be determined on the basis of:

- Required flow rate
- Type of fluid and relative viscosity
- Flow resistance
- Specific gravity and temperature

This flow coefficient K_v is determined as defined in the VDI/VDE 2173 standards. It represents the flow of water in m^3/h or L/min with a temperature from 5 to 30°C which passes through the solenoid valve with a pressure drop of 1 bar.

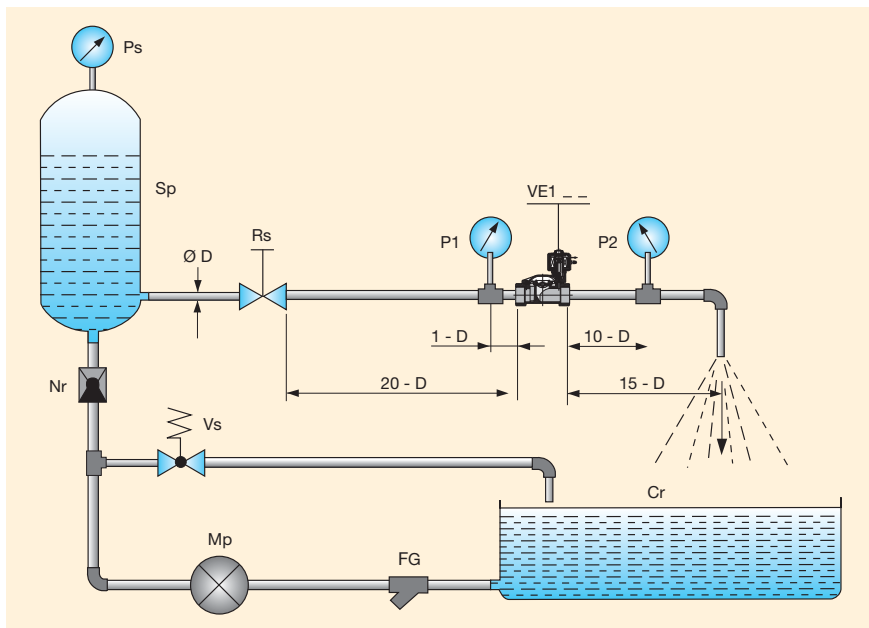

Note:

The flow coefficient used in the USA is known as C_v and represents the water flow rate in US gallons per minute with a pressure drop ΔP of 1 psi.

To convert C_v in K_v and vice versa use:

1 $K_v = 0.862 C_v$
1 $C_v = 1.16 K_v$

FG = Grid Filter **Mp** = Pump **Vs** = Safety Valve **Nr** = Check Valve **Sp** = Pressure Tank **Ps** = Static Pressure Manometer

After existing conditions have been converted into this factor K_v , the type of valve is found by referring to the pages in the related sections in this catalogue.

Parameters used for selecting the solenoid valve are in the table next page.

Consult conversion tables of the various units of measurement as defined by the ISO (International Standards Organisation) - I.S. (International System) set out in this catalogue.

FLOW AND PRESSURE RANGES

Pressure

symbol (P)
unit of measurement [bar]
Working pressure

Pressure drop

symbol (ΔP)
unit of measurement [bar]
Pressure difference between inlet (P_1) and outlet (P_2) of the solenoid valve when a medium is flowing through the valve ($\Delta P = P_1 - P_2$).

Flow coefficient

symbol (Kv)
unit of measurement [l/min]

Specific gravity of the medium

symbol (γ)
unit of measurement [Kg/dm³]

Temperature of the medium

symbol (t)
unit of measurement [°C]

Flow rate

• for liquids
symbol (Q)
unit of measurement [l/min]

• for gases
symbol (Qn)
unit of measurement [Nm³/h]

• for steam
symbol (Qv)
unit of measurement [Kg/h]

Specific volume

symbol (Vs)
unit of measurement [m³/Kg]

a) Solenoid valves for liquids:

Flow rate: $Q = K_v \cdot \sqrt{\frac{\Delta P}{\gamma}}$ where: Q = l/min
 ΔP = bar
 γ = Kg/dm³

Flow coefficient:
 $K_v = Q \cdot \sqrt{\frac{\gamma}{\Delta P}}$

In the case of liquids with viscosity greater than 3°E (22 cStokes) the Kv is modified according to the formula:

$$K_{v1} = K_v + C \quad C = \frac{\delta \cdot \sqrt{K_v}}{200 \cdot Q} + 1$$

where C is the viscosity correction factor calculated by means of the formula:
where:

δ = kinematic viscosity of the fluid expressed in centistokes
Kv = flow rate factor of the solenoid valve
Q = flow rate in l/min

Pressure drop:

$$\Delta P = \gamma \cdot \left(\frac{Q}{K_v}\right)^2$$

b) Solenoid valves for gases:

If $\Delta P \leq 1/2 P_1$ use the following formulae:

Flow rate: $Q_n = 514 \cdot K_v \cdot \sqrt{\frac{\Delta P \cdot P_2}{\gamma_n \cdot (273 + t)}}$

where: $Q_n = \text{Nm}^3/\text{h}$ $P_1 = \text{bar}$ $P_2 = \text{bar}$

Flow coefficient: $K_v = \frac{Q_n}{514} \cdot \sqrt{\frac{(273+t) \cdot \gamma_n}{\Delta P \cdot P_2}}$

$t = ^\circ\text{C}$
 $\gamma_n = \text{Kg}/\text{dm}^3$

Pressure drop: $\Delta P = \frac{(273 + t) \cdot \gamma_n}{P_2} \cdot \frac{Q_n^2}{(514 \cdot K_v)^2}$

If $\Delta P > 1/2 P_1$ use the following formula:

$$Q_n = 757 \cdot K_v \cdot \sqrt{\frac{\Delta P \cdot P_2}{(273 + t) \cdot \gamma_n}}$$

c) Solenoid valves for steam:

If $\Delta P \leq 1/2 P_1$ use the following formulae:

Flow rate: $Q_v = 31,7 \cdot K_v \cdot \sqrt{\frac{\Delta P}{V_s}}$

where: $Q_v = \text{Kg}/\text{h}$ $\Delta P = \text{bar}$ $V_s = \text{m}^3/\text{Kg}$

Flow coefficient: $K_v = \frac{Q_v}{31,7} \cdot \sqrt{\frac{V_s}{\Delta P}}$

Pressure drop: $\Delta P = V_s \cdot \frac{Q_v^2}{(31,7 \cdot K_v)^2}$

If $\Delta P > 1/2 P_1$ use the following formula:

$$Q_v = 22,4 \cdot K_v \cdot \sqrt{\frac{P_1}{V_s}}$$

Notes:

1) Should the value ΔP not be specified, use the following, which is based on experience:

- For liquids only in the case of free discharge $\Delta P = 90\%$ of the input pressure (P_1).
- For gases never use a ΔP of more than 50% of the absolute inlet pressure, since the excessive pressure drop may cause an irregular flow rate. In most cases, ΔP can be considered as 10% of the input pressure.

2) Specific volume value (V_s) for dry saturated steam, see the table in diagram 3.

FLOW RATE FOR LIQUIDS

The liquid flow through a pipe or a valve is given by:

$$Q = K_v \cdot \sqrt{\frac{\Delta P}{\gamma}}$$

- Where
- Q** = Flow [l/min]
 - ΔP** = Differential Pressure [bar]
 - γ** = Density of the fluid [kg/dm³]
(water γ = 1 [kg/dm³])
 - kv** = Flow Factor [l/min]

Flow factor kv:

The kv flow factor of a valve is defined as the flow rate of water in litres per minute with a pressure drop of 1 bar across the valve.

Valve manufactureres use different definitions for kv. It may be expressed in l/h or m³/h.

Care should therefore be taken when comparing values.

Maximum flow rate Qmax.

For particular 2-way valves the maximum flow must be limited for reasons of mechanical resistance and durability.

A very high flow velocity may dislocate a popet sealing or a diaphragm.

Maximum flow rates are indicated in the catalogue.

Flow factors

Kv l/min	KV m ³ /h	Qn l/min
--------------------	--------------------------------	--------------------

NORMALLY CLOSED

Port size	Orifice Ø	Flow factors			Operating Pressure Differential			Fluid Temp.		Seat Seal	Parker LUCIFER® Valves			Power		Coil Group	Dwg. No.
		Kv l/min	KV m ³ /h	Qn l/min	Min	Max(MOPD)	DC	Min	Max		Valve Ref.	Housing Ref.	Coil Ref.	AC	DC		
BSP	mm				bar	AC bar	DC bar	°C	°C								

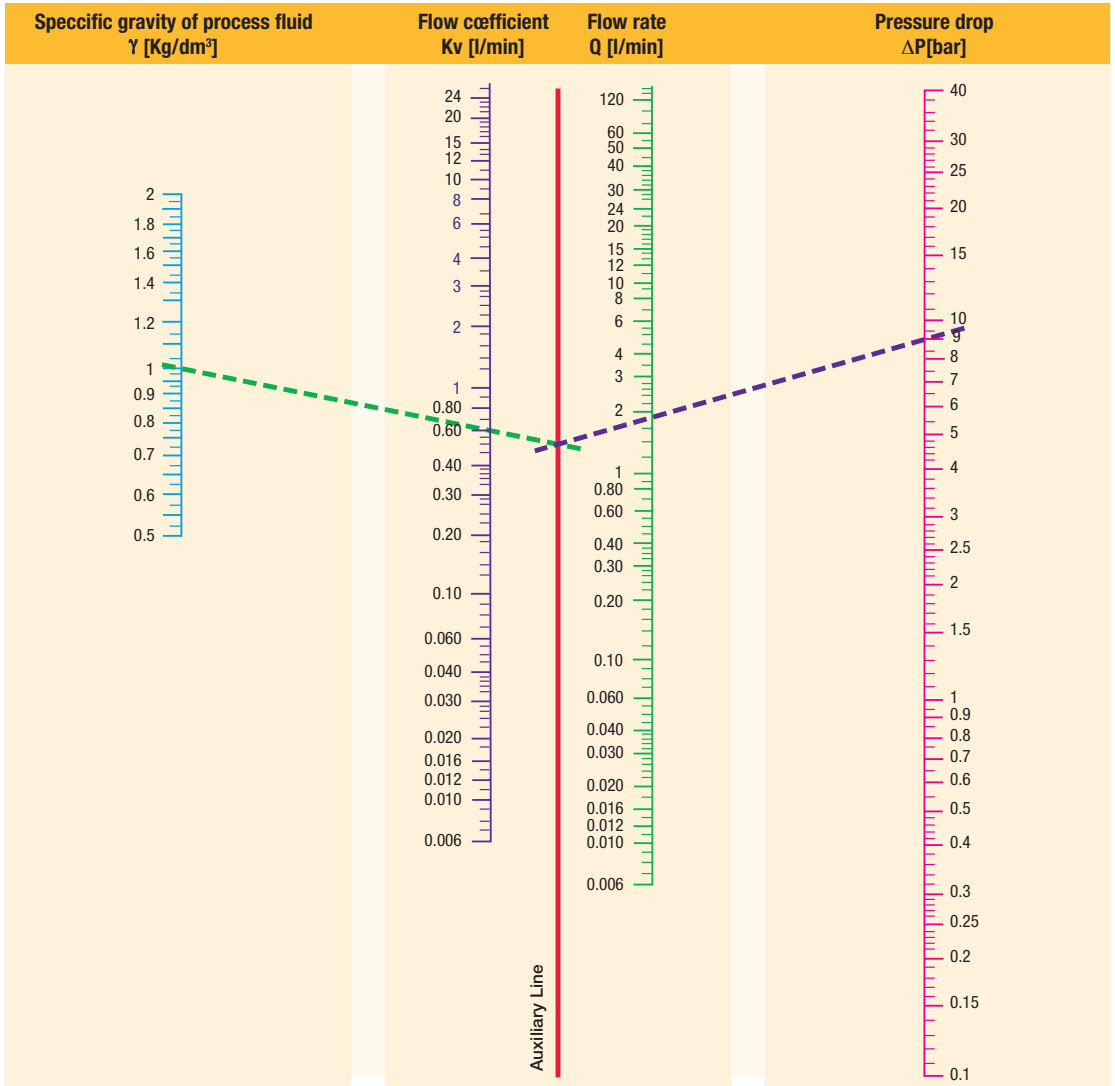

Monogram for liquid flow calculation

Specific gravity of the most common fluids ($\gamma = \text{Kg/dm}^3$) - ($t = 15^\circ\text{C}$ - $P = 760 \text{ mm Hg}$)

Acetone	0.76	Benzenol	0.90	Naphtha	0.76
Water	1.00	Beer	1.02	Pentane	0.63
Sea water	1.02	Hexane	0.66	Vegetable oil	0.92
Ethyl alcohol	0.79	Ethane	0.68	Hydraulic oil	0.92
Methyl alcohol	0.81	Diesel oil	0.70	Wine	0.95
Petrol	0.68	Milk	1.03		

FLOW RATE FOR GASES

The gas flow through a valve is given by:

$$Q = C \cdot P_1 \cdot k_T \cdot \omega \cdot \gamma_{\text{air}} / \gamma_{\text{gas}}$$

Where

- Q** = Flow Rate [**dm³/s**]
- C** = Conductance [**dm³/s.bar**]
- P₁** = Inlet Pressure [**bar abs**]
- γ** = Specific Weight [**Kg/dm³**]
- k_T** = Temperature Correction Factor

$$\omega = \sqrt{1 - \frac{P_2/P_1 - b}{1 - b}}$$

$$k_T = \sqrt{\frac{293}{273 + \text{Temp. } ^\circ\text{C}}}$$

Nominal Flow Q_n:

Calculations can be made with specific flow factors based on the CETOP RP 50P standard. For practical purposes and ease of valve selection the catalogue shows the nominal flow Q_n. The nominal flow Q_n is defined as the flow rate (L/min) of air across the valve when the inlet pressure P₁ = 6 bar and the pressure drop ΔP = 1 bar.

N.B.

The values of the flow factors and flow rates mentioned in catalogues are subject to +/-15% tolerances.

Pneumatic application: $\gamma_{\text{air}} / \gamma_{\text{gas}} = 1$

a) Choked flow conditions $P_2 \leq b \cdot P_1$
in this case $\omega = 1 \rightarrow Q = C \cdot P_1 \cdot k_T$

b) Free flow conditions $P_2 > b \cdot P_1$
in this case $\rightarrow Q = C \cdot P_1 \cdot k_T \cdot \omega$

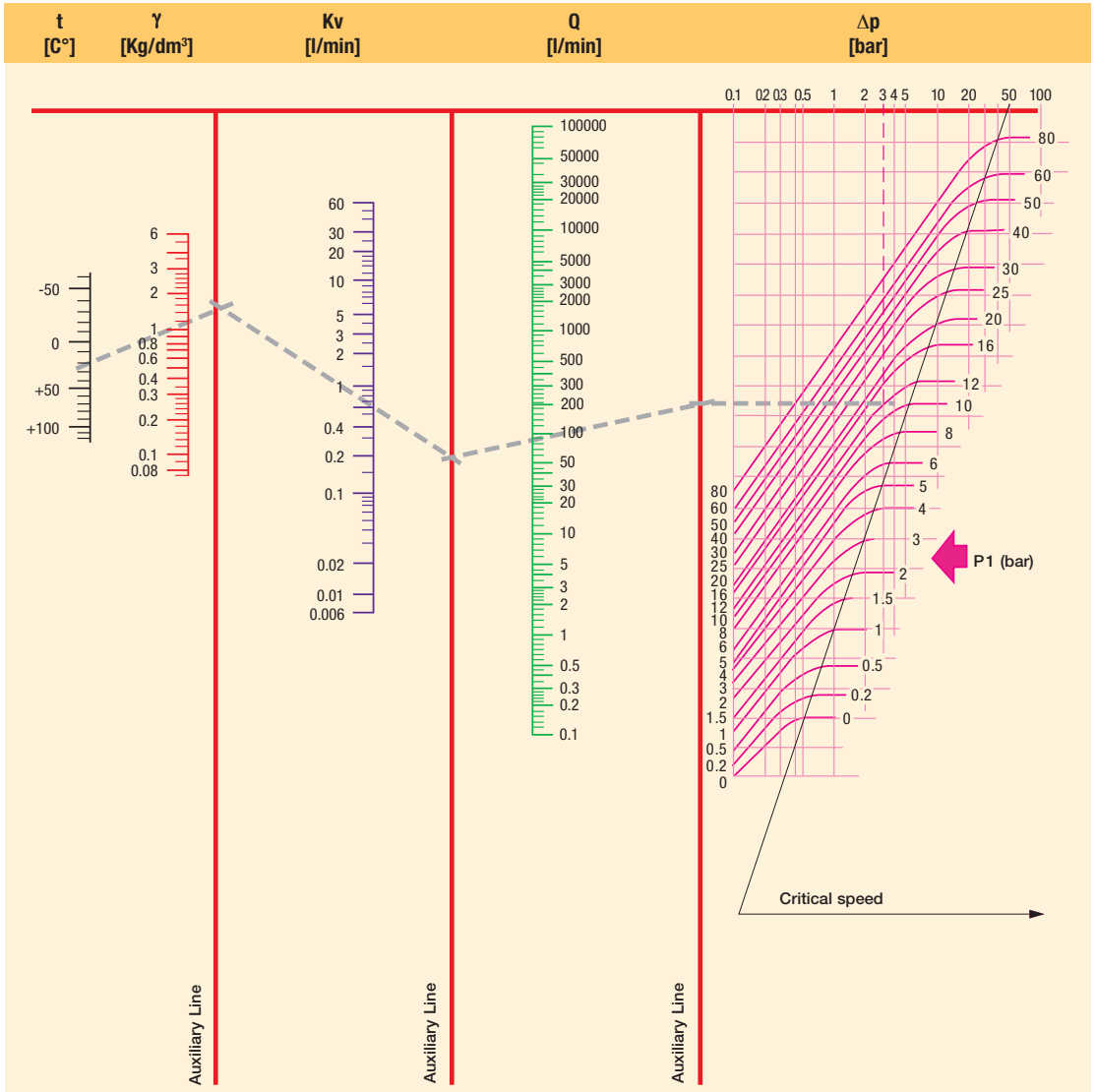

t = Fluid Temperature γN = Specific Gravity Kv = Flow Coefficient Qn = Flow Rate Δp = Pressure Drop P₁ = Inlet Pressure

Specific gravity of the most common gases (γ = Kg/m³) - (t = 0°C - P = 760mm Hg)

Acetylene	1.176	Helium	0.179	Natural gas	0.723
Carbon dioxide	1.965	Ethane	1.035	Methane	0.722
Air	1.293	Ethylene	1.259	Carbon monoxide	1.250
Argon	1.780	Hydrogen	0.089	Oxygen	1.429
Nitrogen	1.255			Propane	1.520
Butane	2.000			Steam	0.805

TECHNICAL INFORMATION

Diagram 3 for Dry Saturated Steam

Steam (Dry Saturated) Data

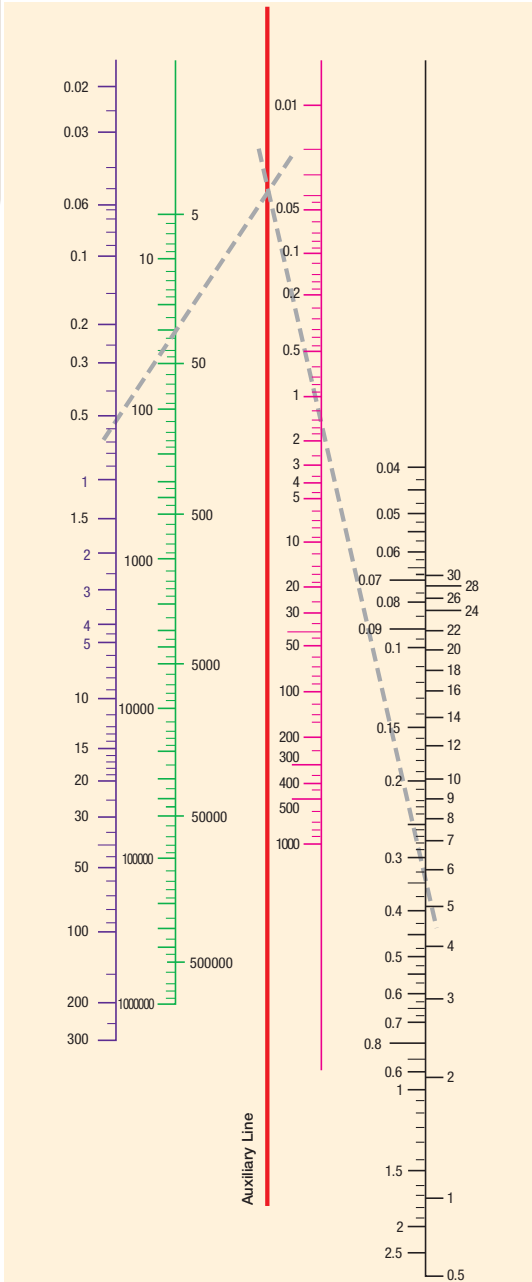

P ₂ bar	Temp. °C	Vs m ³ /Kg	P ₂ bar	Temp. °C	Vs m ³ /Kg
0.01	6.6	131.600	10.00	179.0	0.200
0.02	17.1	68.300	110.00	183.2	0.181
0.03	23.7	46.500	120.00	187.1	0.176
0.04	28.6	35.500	13.00	190.7	0.155
0.05	32.5	28.700	14.00	194.1	0.144
0.06	35.8	24.200	15.00	197.4	0.135
0.08	41.1	18.500	16.00	200.4	0.126
0.10	45.4	15.000	17.00	203.4	0.119
0.20	59.7	7.800	18.00	206.2	0.113
0.30	68.7	5.330	19.00	208.8	0.107
0.40	75.4	4.070	20.00	211.4	0.102
0.50	80.9	3.300	22.00	216.2	0.093
0.60	85.5	2.790	24.00	220.8	0.085
0.70	89.5	2.410	26.00	225.0	0.079
0.80	93.0	2.130	28.00	229.0	0.073
0.90	96.2	1.910	30.00	232.8	0.068
1.00	99.1	1.730	32.00	236.4	0.064
1.50	110.8	1.180	34.00	239.8	0.060
2.00	119.6	0.900	36.00	243.1	0.057
2.50	126.8	0.730	38.00	246.2	0.053
3.00	132.9	0.620	40.00	249.2	0.051
3.50	138.2	0.530	45.00	256.2	0.045
4.00	142.9	0.470	50.00	262.7	0.040
4.50	147.2	0.420	55.00	268.7	0.036
5.00	151.1	0.380	60.00	274.3	0.033
5.50	154.7	0.350	65.00	279.6	0.030
6.00	158.1	0.320	70.00	284.5	0.028
6.50	161.2	0.300	80.00	293.6	0.024
7.00	164.2	0.280	90.00	301.9	0.021
7.50	167.0	0.260	100.00	309.5	0.018
8.00	169.6	0.250	150.00	340.5	0.011
8.50	172.1	0.230	200.00	364.2	0.006
9.00	174.5	0.220	225.00	374.0	0.003
9.50	176.8	0.210			

Kv = Flow Coefficient

Qv = Flow Rate

Δp = Pressure Drop

Vs = Specific Volume

P₂ = Outlet Pressure

VISCOSITY CONVERSION TABLE

Centistokes cStokes mm ² /S	°Engler °E	Saybolt Universal Second SSU	Rewood Second N°1 SRW N°1
1	1	-	-
12	2	65	55
22	3	100	90
30	4	140	120
28	5	175	155
45	6	210	185
60	8	275	245
75	10	345	305
90	12	415	370
115	15	525	465
150	20	685	610
200	26	910	810
300	39	1 385	1 215
400	53	1 820	1 620
500	66	2 275	2 025
750	97	3 365	2 995
1 500	197	6 820	6 075

OTHER USEFUL FORMULAS

Formulas:

$$^{\circ}\text{C} = (^{\circ}\text{F} - 32) \times 5/9$$

$$^{\circ}\text{F} = (^{\circ}\text{C} \times 9/5) + 32$$

$$\text{m}^3/\text{h} = \text{l}/\text{min} \times 0.06$$

$$\text{l}/\text{min} = \text{m}^3/\text{h} \times 16,67$$

$$\text{m}^3/\text{sec} = \text{m}^3/\text{h} \times 2,778 \times 10^{-4}$$

$$\text{m}^3/\text{sec} = \text{l}/\text{min} \times 1,667 \times 10^{-5}$$

Examples:

$$(167^{\circ}\text{F}-32) \times 5/9 = 75^{\circ}\text{C}$$

$$(30^{\circ}\text{C} \times 9/5) + 32 = 86^{\circ}\text{F}$$

$$100 \text{ l}/\text{min} \times 0.06 = 6 \text{ m}^3/\text{h}$$

$$9 \text{ m}^3/\text{h} \times 16,67 = 150 \text{ l}/\text{min}$$

$$18.000 \text{ m}^3/\text{h} \times 2.778 \times 10^{-4} = 5 \text{ m}^3/\text{sec}$$

$$479.904 \text{ l}/\text{min} \times 1.667 \times 10^{-5} = 8 \text{ m}^3/\text{sec}$$

TABLE OF SUB-BASES FOR VALVES (Examples)

This table is showing examples of existing Sub-bases and possible Valves associations.
For more detail see sub-bases drawings in the following pages.

Sub-Base Reference	488860.01 /.02/.03 /.04/.05	486162 /63/64	485635 /36/37	481168 /.04/.06 /.08/.10	481964.04 /.06/.08/.10	485291	485290	XGSPG1 /XGSPG2
Drawing	1	2	3	4	5	6	7	8
Valve Reference								
131F4480	●							
131F4480		●						
131F46		●						
131F4650		●						
131M74	●							
131M74	●							
131M7450	●							
131M7450	●							
131M75	●							
131M7550	●							
132F43		●						
132F44		●						
132F46		●						
133F46		●						
133F4650		●						
2019F1								●
3019F1								●
301XGR								●
341F34			●					
341F3403			●					
341L11					●			
341L2190							●	
341L9101				●				
345F34			●					
347L11					●			
E131F26								
E131F43		●						
E131F4350		●						
E131F44		●						
E131F4450		●						
E133F43		●						
E133F4350		●						
E133F44		●						
E133F4450		●						
E331L21						●		

TABLE OF SUB-BASES FOR VALVES (Examples)

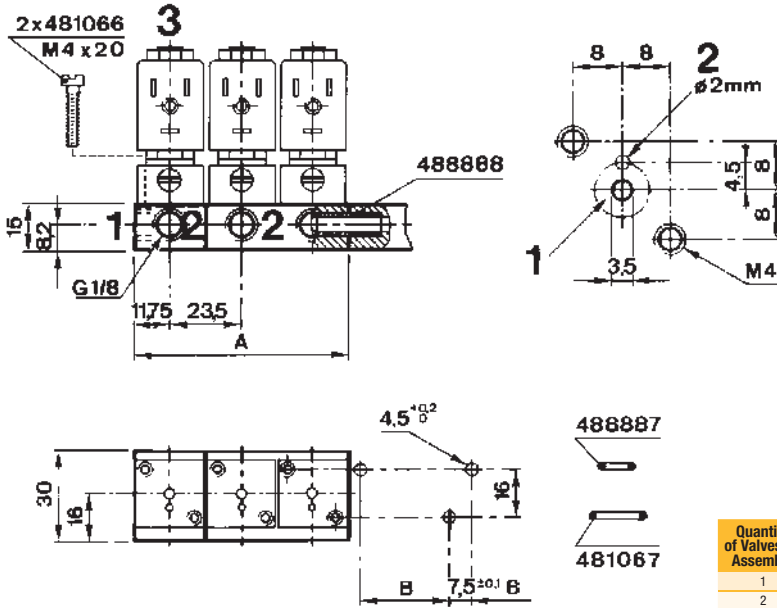

Drawing 1

Quantity of Valves by Assembly	Reference Numbers	A mm	B mm	Weight g
1	488860-01	23.5	16.0 ± 0.1	25
2	488860-02	47.0	39.5 ± 0.1	45
3	488860-03	70.5	63.0 ± 0.1	70
4	488860-04	94.0	86.5 ± 0.1	120
5	488860-05	117.5	110.0 ± 0.1	120

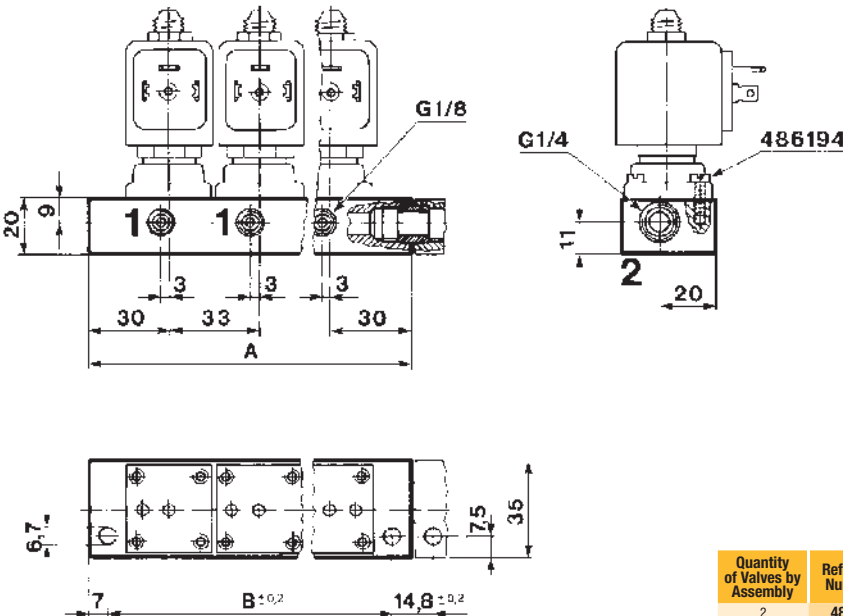

Drawing 2

Quantity of Valves by Assembly	Reference Numbers	A mm	B mm	Weight g
2	486162	93	79	150
3	486163	126	112	210
5	486164	192	178	420

TABLE OF SUB-BASES FOR VALVES (Examples)

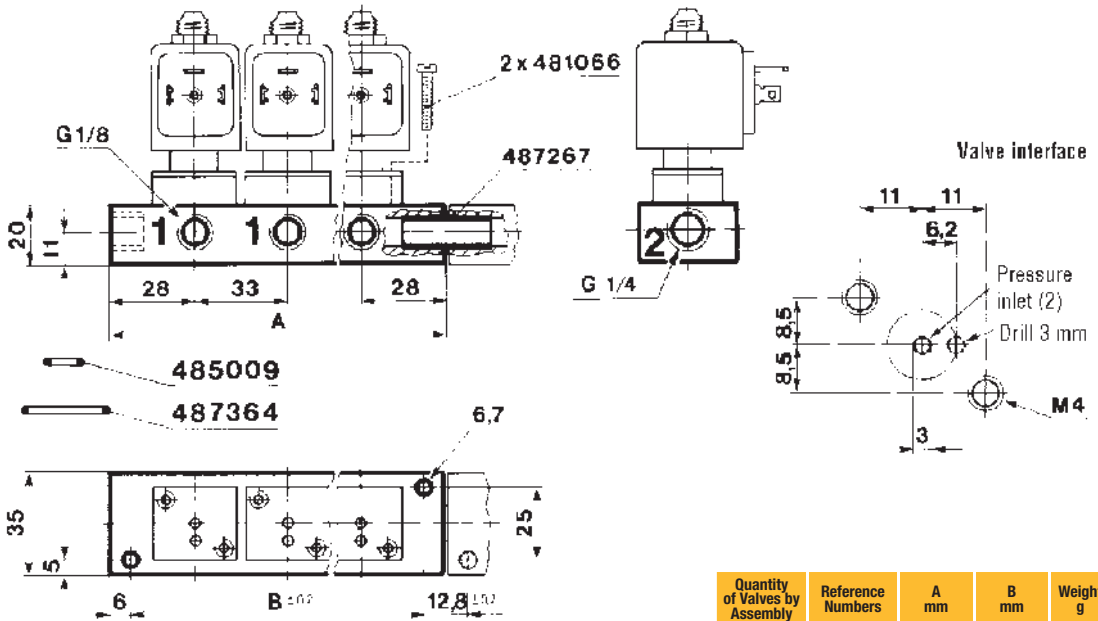

Drawing 3

Quantity of Valves by Assembly	Reference Numbers	A mm	B mm	Weight g
1	487165	56	44	85
2	487167	89	77	135
3	487169	188	176	300

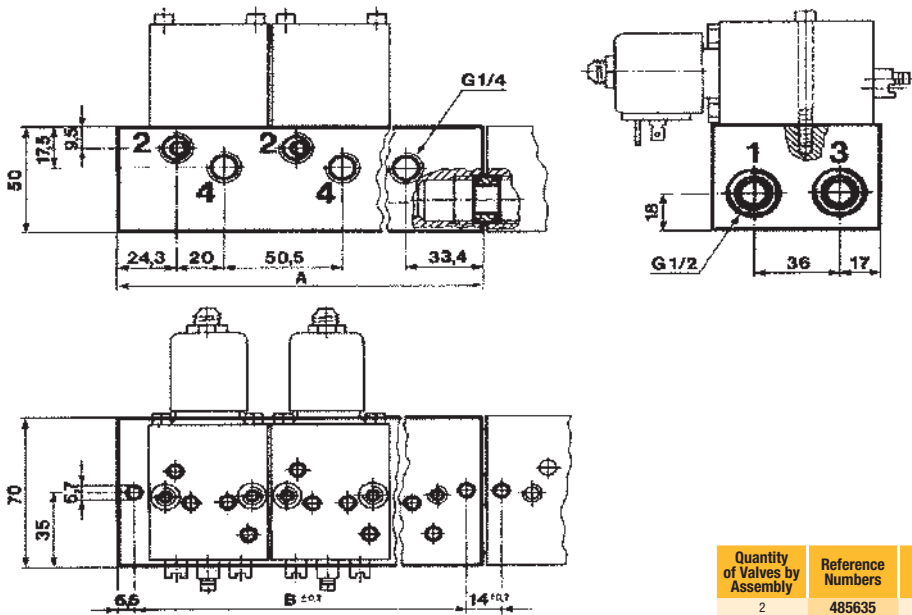

Drawing 4

Quantity of Valves by Assembly	Reference Numbers	A mm	B mm	Weight g
2	485635	128.2	115.0	1000
3	485636	178.7	165.5	1400
5	485637	279.7	266.5	2250

TABLE OF SUB-BASES FOR VALVES (Examples)

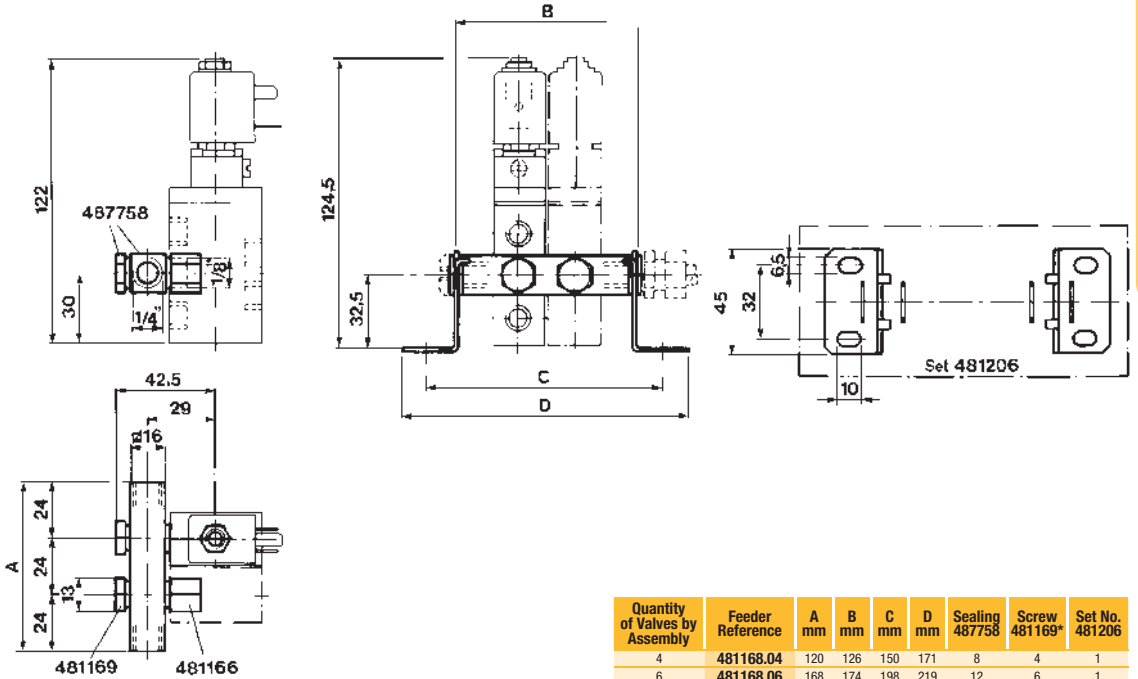

Drawing 5

Quantity of Valves by Assembly	Feeder Reference	A mm	B mm	C mm	D mm	Sealing 487758	Screw 481169*	Set No. 481206
4	481168.04	120	126	150	171	8	4	1
6	481168.06	168	174	198	219	12	6	1
8	481168.08	216	222	246	267	16	8	1
10	481168.10	264	270	294	315	20	10	1

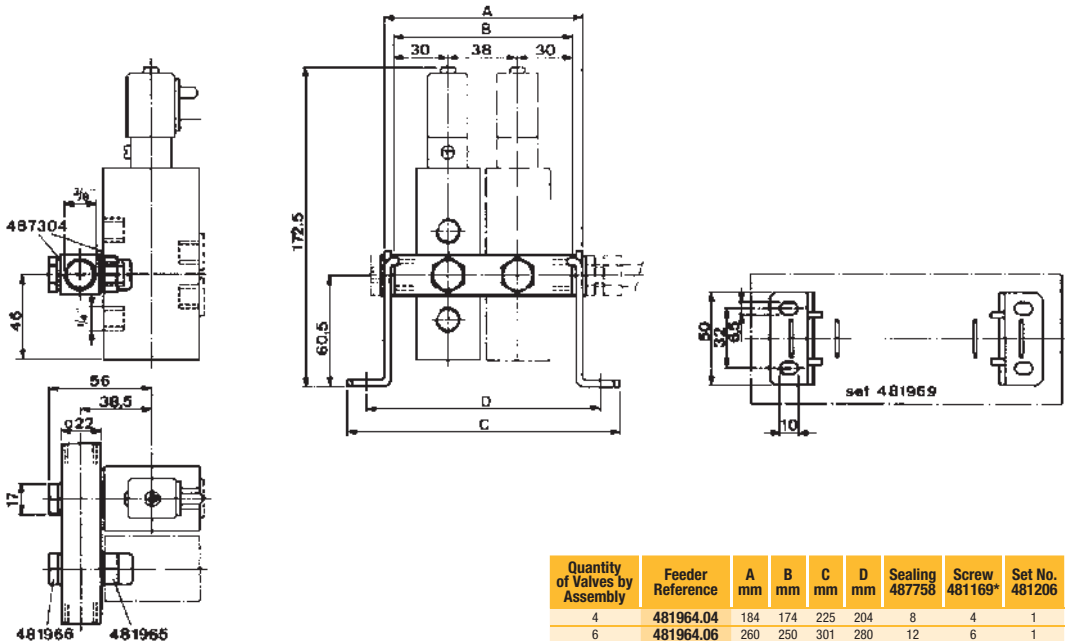

Drawing 6

Quantity of Valves by Assembly	Feeder Reference	A mm	B mm	C mm	D mm	Sealing 487758	Screw 481169*	Set No. 481206
4	481964.04	184	174	225	204	8	4	1
6	481964.06	260	250	301	280	12	6	1
8	481964.08	336	326	377	356	16	8	1
10	481964.10	412	402	453	432	20	10	1

TABLE OF SUB-BASES FOR VALVES (Examples)

Sub-base 485291

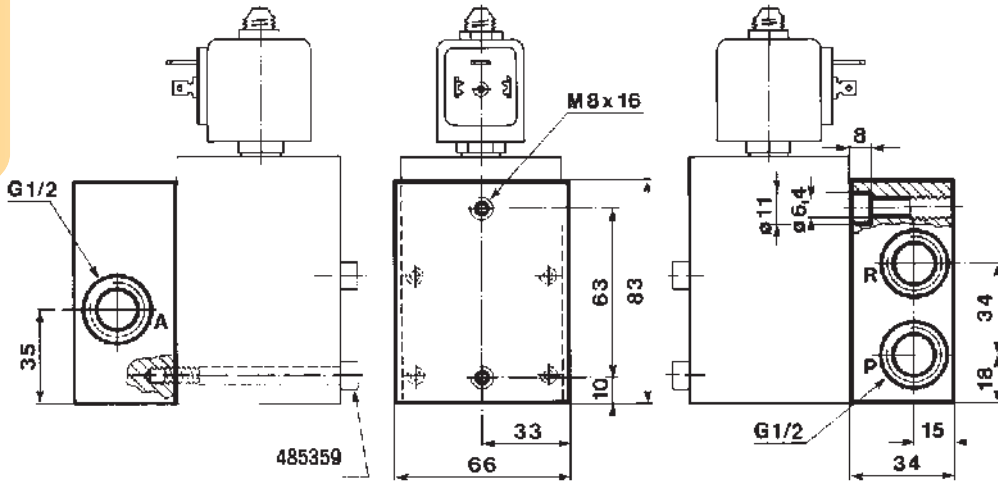

Drawing 7

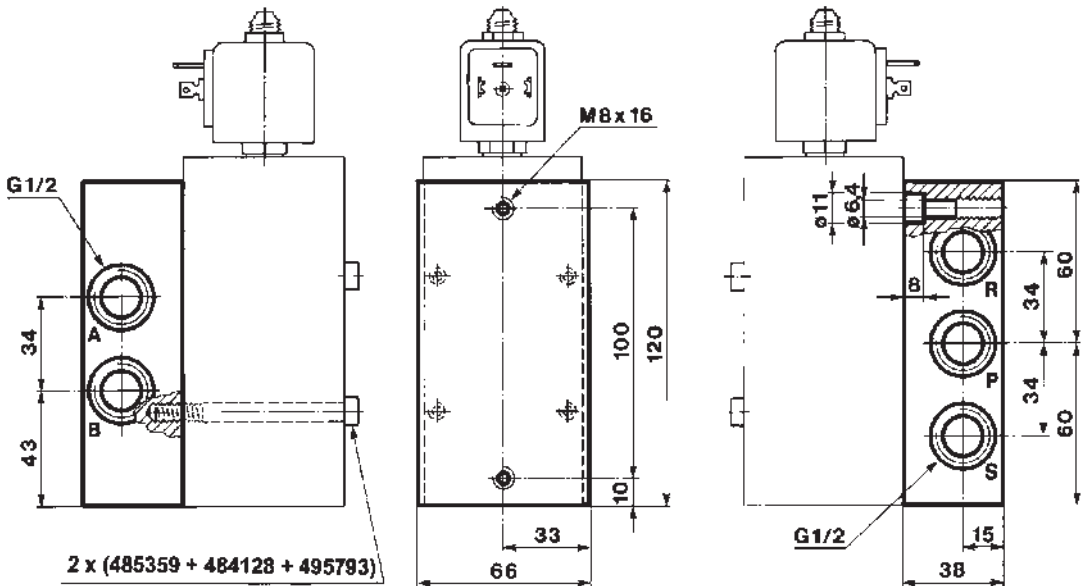

Drawing 8

TABLE OF SUB-BASES FOR VALVES (Examples)

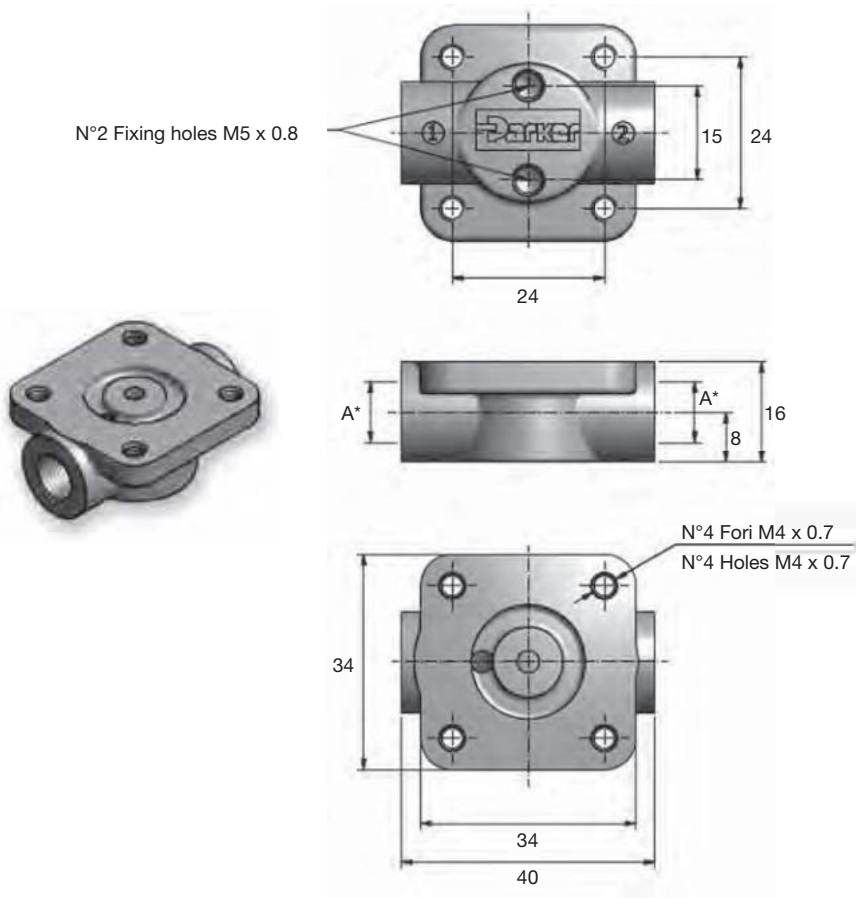

Drawing 9

Port	Kit Reference	To be used with	Box Quantity	Screws
1/8" G	XGSPG1	Any version	10	Included
1/4" G	XGSPG2	Any version	10	Included

TABLE OF VOLTAGE CODES FOR COILS AND ELECTRICAL PARTS

This table is showing the most commonly used voltage codes, for other voltages, please ask us.

VOLTAGE CODES			C1	C2	N7	L8	C4	C5	C7	E6	P1	A5	0A	S5	P2	1P	6J	0P	P3	K8	
Coil	Group	Sub-Group	12 DC	24 DC	28 DC	30 DC	48 DC	110 DC	196 DC	220 DC	100/50	100/50-60	110/50	110-115/50	110-115/50 120/60	110/50-60	110-115/50-60	110-115/60	100/50-115/60	110/50-120/60	115/60
481045	1.1	-	●	●			●	●						●				●			
481180	1.1	-	●	●				●						●							
481530	1.1	-	●	●																	
482605	1.1	-	●	●																	
482606	1.1	-	●	●			●	●						●				●			
483590	1.1	-													●						
488143	1.1	-										●									
488980	1.1	-	●	●			●	●						●				●			
492912	1.1	-		●																	
492919	1.1	-		●																	
495865	1.1	-		●			●							●				●			
496131	1.2	-	●	●			●	●							●						●
496482	1.2	-	●	●			●	●							●						●
496637	1.2	-	●	●			●	●							●						●
WB4.5	1.3	-									●	●								●	
WB5.0	1.3	-	●	●				●													
WB8.0	1.3	-																		●	
481000	2.0	2.1	●	●			●	●	●					●				●			
481865	2.0	2.1	●	●			●	●													●
482635	2.0	2.1													●						
482725	2.0	2.1	●	●				●						●							●
483371	2.0	2.1	●	●			●	●		●				●				●			
483510	2.0	2.1													●						
483520	2.0	2.1																			
485100	2.0	2.1		●						●				●							
488553	2.0	2.1								●				●							
488947	2.0	2.1									●										
491514	2.0	2.1	●	●		●														●	
492070	2.0	2.1	●	●			●	●								●					
492190	2.0	2.1	●	●			●	●		●						●					
492453	2.0	2.1	●	●			●	●						●							
492670	2.0	2.1	●	●			●	●						●							
492726	2.0	2.1		●																	
493640	2.0	2.1		●			●							●						●	
494040	2.0	2.1		●						●				●							
495870	2.0	2.1		●			●	●						●							
495905	2.0	2.1		●			●	●													●
496081	2.0	2.1	●	●																	
496082	2.0	2.1	●	●											●					●	
496110	2.0	2.1													●						
HZ10	2.0	2.1																		●	
481044	2.0	2.2												●					●		
483816	2.0	2.2	●	●																	
486265	2.0	2.2	●	●			●							●					●		
492425	2.0	2.2	●	●										●							
492727	2.0	2.2	●	●										●							
495880	2.0	2.2		●										●							
496155	2.0	2.2		●			●							●							
HZ11	2.0	2.2	●	●			●													●	
482730	3.0	-		●			●							●							●
482735	3.0	-		●			●														
495875	3.0	2.1		●																	

TABLE OF VOLTAGE CODES FOR COILS AND ELECTRICAL PARTS

This table is showing the most commonly used voltage codes, for other voltages, please ask us.

VOLTAGE CODES			C1	C2	N7	L8	C4	C5	C7	E6	P1	A5	0A	S5	P2	1P	6J	0P	P3	K8	
Coil	Group	Sub-Group	12 DC	24 DC	28 DC	30 DC	48 DC	110 DC	196 DC	220 DC	100/50	100/50-60	110/50	110-115/50	110-115/50 120/60	110/50-60	110-115/50-60	110-115/60	100/50-115/60	110/50-120/60	115/60
484990	4.0	-																			
485400	4.0	-	●	●			●	●									●				
495915	4.0	-		●			●										●				
482740	6.0	-		●			●	●													
482745	6.0	-		●			●														
495900	6.0	-	●	●			●	●													●
496125	6.0	-		●			●	●													
483580.01	7.0	-			●																
488650.01	7.0	-			●																
488660.01	7.0	-			●																
488670.01	7.0	-			●																
490885	7.0	-				●															
490890	7.0	-			●	●															
495910	8.0	-			●																
492210	9.0	-		●																	
492965.01	9.0	-			●																
496565	9.0	-			●																
492300	10.1	-	●	●			●	●		●						●					
492310	10.1	-	●	●			●	●		●						●					
496560	10.1	-		●			●	●								●					
496800	10.1	-		●			●	●								●					
496800.02	10.1	-		●			●	●								●					
496895	10.1	-		●			●	●								●					
496555	10.2	-		●			●	●								●					
496700	10.2	-		●			●	●								●					
496700.02	10.2	-		●			●	●								●					
497105	10.3	-	●	●			●	●									●				
483270	11.0	-	●	●			●	●									●				
483270.02	11.0	-	●	●			●	●									●				
492335	12.0	-				●															
482870.01	12.0	-			●																
495294	13.0	-	●	●																	
496193	13.0	-	●	●																	
483824	14.1	-																			
483764	14.2	-																			
483541	14.3	-																			
YB09	20.1	-															●			●	
YB12	20.1	-	●	●																	
ZB09	20.1	-	●	●			●	●			●						●			●	
ZB12	20.1	-	●	●			●	●													
ZB14	20.2	-									●									●	
ZB16	20.2	-	●	●				●													
ZH14	20.2	-																		●	
ZH16	20.2	-	●	●																	
JB14	21.0	-																			
JB16	21.0	-	●	●					●												
KH09	22.0	-																			
KP10	22.0	-	●	●																	
KT09	22.0	-												●							
XT09	23.0	-																			
D4	24.0	-		●																	●
D5	24.0	-		●																	●
LA	24.0	-		●									●							●	
LB-LC	24.0	-		●																●	
XS03	24.0	-																		●	

A1	1W	P6	S2		U3	A7	B7	R5	3D	7J	3P	4K	Q3	S6	F4	J3	P9	A2	B2	P0	A8	B8	Q1	A9	Q2	5P	A4	S4	
12/50	12/50-60	200/50-60	200-230/60		208-230/60	208-240/60	220/50	220/60	220/50-60	220-230/50	220-230/60	220-230/50-60	220-240/60	220/50-240/60	220-240/50	230/50	230/60	230/50-60	24/50	24/60	24/50-60	240/50	240/60	240/50-60	380/50	380/50-60	380/50-440/60	48/50	48/50-60
		•									•										•								•
											•										•								•
															•				•				•					•	

INDEX BY COIL REFERENCE

Coil Reference	Coil Group	Designation	Power DC Pn (W)	Power AC Pn (W)	Ambient Temperature	UL	Degree of Protection	ATEX or NEMA 4X Protection (Gas)	Page
481000	2.0/2.1	Coil with screw terminal, 40 mm	8.0	8.0	-40°C to +50°C	-	IP 44 to 67	-	474
481044	2.0/2.2	Coil with screw terminal High power, 40 mm	-	14.0	-40°C to +50°C	-	IP 44 to 67	-	475
481180	1.1	Coil for DIN plug connection, 22 mm	5.0	4.0	-40°C to +50°C	-	IP65	-	453
481865	2.0/2.1	Coil for DIN plug connection, 32 mm	9.0	8.0	-40°C to +50°C	-	IP65	-	446
482605	1.1	Explosion proof encapsulated electrical part "mb", 32 mm	5.0	4.0	-40°C to +65°C	-	IP65	II 2 G Ex mb IIC T4/T5	494
482606	1.1	Explosion proof encapsulated electrical part "mb", low power, 32 mm	2.5	2.0	-40°C to +65°C	-	IP65	II 2 G Ex mb IIC T4/T5	494
482730	3.0	Coil for DIN plug connection, reduced power, 32 mm	7.0	6.0	-40°C to +50°C	-	IP65	-	448
482740	6.0	Coil for DIN plug connection, low power, 32 mm	1.6	-	-40°C to +50°C	-	IP65	-	449
482870.01	12.0	Explosion proof intrinsically safe electrical part "ia", 50 mm	3.0	-	-40°C to +65°C	-	IP66	II 1 G Ex ia IIC T6	512
483270	11.0	Flame proof electrical part "db", 50 mm	8.0	8.0	-40°C to +80°C	-	IP66	II 2 G Ex db IIC T4/T5/T6	492
483371	2.0/2.1	Explosion proof increased safety electrical part "eb", 50 mm	8.0	8.0	-40°C to +65°C	-	IP67	II 2 G Ex eb IIC T4	504
483510	2.0/2.1	Coil for DIN plug connection, 32 mm	-	9.0	-40°C to +50°C	-	IP65	-	446
483520	2.0/2.1	Coil with screw terminal, double frequency, 40 mm	-	9.0	-40°C to +50°C	-	IP 44 to 67	-	474
483541	14.3	Coil with screw terminal, high temperature-high power, 40 mm	20.0	20.0	-40°C to +50°C	-	IP 44 to 67	-	478
483580.01	7.0	Explosion proof intrinsically safe electrical part "ia", 32 mm	3.0	-	-40°C to +55°C	-	IP65	II 1 G Ex ia IIC T6	508
483590	1.1	Coil for DIN plug connection, double frequency, 22 mm	-	3.0	-40°C to +50°C	-	IP65	-	455
483764	14.2	Coil for DIN plug connection, UL recognized	-	9.0	-40°C to +50°C	-	IP65	-	451
483816	2.2	Coil for DIN plug connection for Jet Valves, 32 mm	14.0	14.0	-40°C to +50°C	-	IP65	-	452
483824	14.1	Coil with screw terminal, high temperature-high power, 40 mm	19.0	19.0	-40°C to +50°C	-	IP 44 to 67	-	477
484990	4.0	Coil with screw terminal, bistable, for impulse applications, 40 mm	-	11.0	-40°C to +50°C	-	IP44	-	480
485100	2.0/2.1	Coil with screw terminal, high temperature, 40 mm	8.0	8.0	-40°C to +50°C	-	IP 44 to 67	-	476
485400	4.0	Coil with screw terminal, bistable, for impulse applications, 40 mm	13.0	-	-40°C to +50°C	-	IP44	-	480
486265	2.0/2.2	Coil with screw terminal, high temperature-high power, 40 mm	14.0	14.0	-40°C to +50°C	-	IP 44 to 67	-	476
488143	1.1	Coil for DIN plug connection, double frequency, 22 mm	-	2.5	-40°C to +50°C	-	IP65	-	456
488553	2.0/2.1	Coil with screw terminal, double frequency, H class, 40 mm	-	9.0	-40°C to +50°C	-	IP 44 to 67	-	479
488650.01	7.0	Explosion proof intrinsically safe electrical part "ia", 50 mm	0.3 to 3.0	-	-40°C to +65°C	-	IP66	II 1 G Ex ia IIC T6	513
488660.01	7.0	Explosion proof intrinsically safe electrical part "ia", 50 mm	3.0	-	-40°C to +65°C	-	IP67	II 1 G Ex ia IIC T6	514
488670.01	7.0	Explosion proof intrinsically safe electrical part "ia", 50 mm	0.3 to 3.0	-	-40°C to +65°C	-	IP65	II 1 G Ex ia IIC T6	515
488980	1.1	Coil for DIN plug connection, low power, 22 mm	2.5	2.0	-40°C to +50°C	-	IP65	-	453
490885	7.0	Explosion proof intrinsically safe electrical part, "NEMA", 50 mm	3.0	-	-40°C to +60°C	-	NEMA 4 - 4X	Cl. I, Div.I, Gr. A, B, C, D	513
490890	7.0	Explosion proof intrinsically safe electrical part, "NEMA", 50 mm	3.0	-	-40°C to +60°C	-	NEMA 4 - 4X	Cl. I, Div.I, Gr. A, B, C, D	514
491514	2.0/2.1	Coil for DIN plug connection, 32 mm, UL class F	-	11.0	-40°C to +50°C	●	IP65	-	450
492070	2.0/2.1	Explosion proof encapsulated electrical part "mb", with water proof metal housing, 50mm	8.0	9.0	-40°C to +65°C	-	IP67	II 2 G Ex mb IIC T4/T5	496
492190	2.0/2.1	Explosion proof increased safety and encapsulated electrical part "eb", 50 mm	9.0	11.0	-40°C to +75°C	-	IP66	II 2 G Ex eb mb IIC T3/T4	507
492210	9.0	Explosion proof increased safety and encapsulated electrical part "eb", "Booster", 50 mm	1.0 to 1.8	-	-40°C to +75°C	-	IP66	II 2 G Ex eb mb IIC T5/T6	506
492310	10.1	Explosion proof increased safety and encapsulated electrical part "eb", 50 mm	6.0	6.0	-40°C to +75°C	-	IP66	II 2 G Ex eb mb IIC T4/T5	505
492335	12.0	Explosion proof intrinsically safe electrical part, "NEMA", 50 mm	3.0	-	-40°C to +60°C	-	NEMA 4 - 4X	Cl. I, Div.I, Gr. A, B, C, D	512
492425	2.0/2.2	Coil for DIN plug connection, high temperature, 32 mm	14.0	14.0	-40°C to +50°C	-	IP65	-	447
492453	2.0/2.1	Coil for DIN plug connection, high temperature, 32 mm	9.0	8.0	-40°C to +50°C	-	IP65	-	447
492670	2.0/2.1	Explosion proof encapsulated electrical part "mb", 32 mm	9.0	8.0	-40°C to +50°C	-	IP65	II 2 G Ex mb IIC T4	495
492912	1.1	Coil for DIN plug connection, 22 mm, UL	4.0	3.0	-40°C to +50°C	●	IP65	-	454
492965.01	9.0	Explosion proof intrinsically safe electrical part "ia", "Booster", 50 mm	0.3 to 2.3	-	-40°C to +65°C	-	IP66	II 1 G Ex ia IIC T6	511
493640	2.0/2.1	Flame proof encapsulated electrical part "db mb", double frequency	8.0	8.0	-40°C to +75°C	-	IP65	II 2 G Ex db mb IIC T4/T5	503
494040	2.0/2.1	Explosion proof increased safety electrical part "eb", 50 mm	8.0	8.0	-40°C to +90°C	-	IP67	II 2 G Ex eb IIC T3/T4	504
495294	13.0	Coil with ISO-DIN connector, 12-24VDC for transportation applications, 32 mm	9.0	-	-40°C to +120°C	-	IP69K	-	481
495865	1.1	Explosion proof electrical part "nAc nCc", low power, 22 mm	2.5	2.0	-40°C to +50°C	-	IP65	II 3 G Ex nAc nCc IIC T5	484
495870	2.0/2.1	Explosion proof electrical part "nAc nCc", 32 mm	9.0	8.0	-40°C to +50°C	-	IP65	II 3 G Ex nAc nCc IIC T3/T4	486

INDEX BY COIL REFERENCE

Coil Reference	Coil Group	Designation	Power DC Pn (W)	Power AC Pn (W)	Ambient Temperature	UL	Degree of Protection	ATEX or NEMA 4X Protection (Gas)	Page
495875	3.0	Explosion proof electrical part "nAc nCc", 32 mm	7.0	6.0	-40°C to +50°C	-	IP65	II 3 G Ex nAc nCc IIC T3/T4	488
495880	2.0/2.2	Explosion proof electrical part "nAc nCc", 32 mm	14.0	14.0	-40°C to +50°C	-	IP65	II 3 G Ex nAc nCc IIC T3	489
495900	6.0	Flame proof encapsulated electrical part "db mb", low power, 37 mm	2.0	2.5	-40°C to +65°C	-	IP67	II 2 G Ex db mb IIC T4 / T5/T6	499
495905	2.0/2.1	Flame proof encapsulated electrical part "db mb", 37 mm	8.0	8.0	-40°C to +65°C	-	IP67	II 2 G Ex db mb IIC T4	500
495910	8.0	Explosion proof intrinsically safe electrical part "ia", "booster", 37 mm	0.3 to 1.2	-	-40°C to +80°C	-	IP67	II 1 G Ex ia IIC T4/T5/T6	509
495915	4.0	Explosion proof increased safety electrical part "nAc nCc", 50 mm	13.0	11.0	-40°C to +65°C	-	IP67	II 3 G Ex nAc nCc IIC T3	490
496081	2.0/2.1	Coil with flying leads, IP67, 32 mm	9.0	9.0	-40°C to +50°C	-	IP67	-	472
496082	2.0/2.2	Coil with flying leads, IP67, 32 mm, UL	16.0	13.0-14.0	-40°C to +120°C	●	IP67	-	473
496110	2.0/2.1	Explosion proof electrical part "nAc nCc", 32 mm	-	9.0	-40°C to +50°C	-	IP65	II 3 G Ex nAc nCc IIC T3/T4	486
496125	6.0	Explosion proof electrical part "nAc nCc", low power, 32 mm	1.6	-	-40°C to +50°C	-	IP65	II 3 G Ex nAc nCc IIC T5/T6	487
496131	1.2	Coil for DIN plug connection, double frequency, 22 mm	3.0	3.0	-40°C to +50°C	-	IP65	-	457
496155	2.0/2.2	Explosion proof increased safety electrical part "nAc nCc", 50 mm	14.0	14.0	-40°C to +65°C	-	IP67	II 3 G Ex nAc nCc IIC T3	491
496193	13.0	Coil with ISO-DIN connector, 12-24VDC, for transportation applications, 32 mm	9.0	-	-40°C to +120°C	-	IP69K	-	481
496482	1.2	Coil for DIN plug connection, double frequency coil, 22 mm	3.0	3.0	-40°C to +50°C	-	IP65	-	458
496555	10.2	Flame proof encapsulated electrical part "db mb", 37 mm	6.0	6.0	-40°C to +65°C	-	IP67	II 2 G Ex db mb IIC T4/T5/T6	501
496560	10.1	Flame proof encapsulated electrical part "db mb", 37 mm	8.0	8.0	-40°C to +65°C	-	IP67	II 2 G Ex db mb IIC T4	501
496565	9.0	Explosion proof intrinsically safe electrical part "ia", "Booster", 37 mm	0.77 to 2.58	-	-40°C to +80°C	-	IP67	II 1 G Ex ia IIC T4/T5/T6	510
496637	1.2	Explosion proof electrical part "nAc nCc", double frequency, 22 mm	3.0	3.0	-20°C to +50°C	-	IP65	II 3 D Ex TC IIC T 95°C	485
496700	10.2	Flame proof encapsulated electrical part "db mb", 37 mm	6.0	6.0	-40°C to +65°C	-	IP67	II 2 G Ex db mb IIC T4 / T5 / T6	502
496800	10.1	Flame proof encapsulated electrical part "db mb", 37 mm	8.0	8.0	-40°C to +65°C	-	IP67	II 2 G Ex db mb IIC T4	502
496895	10.1	Coil for DIN plug connection for oil and gas, 37 mm	8.0	8.0	-40°C to +50°C	-	IP65	-	468
497105	10.3	Flame proof stainless steel electrical part "db"	8.0	8.0	-50°C to +80°C	-	IP66	II 2 G Ex db IIC T4/T5/T6	493
D4	24.0	Coil for DIN plug connection, 32 mm, UL	16.0	13.0	-40°C to +50°C	●	IP65	-	465
D5	24.0	Coil for DIN plug connection, 32 mm	9.0	8.0	-40°C to +50°C	-	IP65	-	466
HZ10	2.0/2.1	Explosion proof encapsulated electrical part "mb", double frequency	8.0	8.0	-40°C to +85°C	-	IP65	II 2 G Ex mb IIC T3/T4/T5	497
HZ11	2.0/2.2	Explosion proof encapsulated electrical part "mb", double frequency	14.0	14.0	-40°C to +85°C	-	IP65	II 2 G Ex mb IIC T3/T4/T5	498
JB14	21.0	Coil for DIN plug connection	16.0	-	-10°C to +50°C	-	IP65	-	462
JB16	21.0	Coil for DIN plug connection	-	14.0	-10°C to +50°C	-	IP65	-	462
KH09	22.0	Coil for DIN plug connection	-	9.0	-10°C to +80°C	-	IP65	-	463
KT09	22.0	Coil for DIN plug connection	-	9.0	-10°C to +50°C	-	IP65	-	463
KT10	22.0	Coil for DIN plug connection	10.0	-	-10°C to +50°C	-	IP65	-	463
LA	24.0	Coil with flying leads, IP67, 32 mm	9.0	9.0	-10°C to +50°C	-	IP67	-	470
LB-LC	24.0	Coil with flying leads, 32 mm, UL	16.0	13.0-14.0	-10°C to +50°C	●	IP67	-	471
WB4.5	1.3	Coil for DIN plug connection, 22 mm	-	4.5	-10°C to +50°C	-	IP65	-	459
WB4.5 UR	1.3	Coil for DIN plug connection, 22 mm	-	4.5	-10°C to +50°C	●	IP65	-	459
WB5.0	1.3	Coil for DIN plug connection, 22 mm	5.0	-	-10°C to +50°C	-	IP65	-	459
WB5.0 cURus	1.3	Coil for DIN plug connection, 22 mm	5.0	-	-10°C to +50°C	●	IP65	-	459
WB8.0	1.3	Coil for DIN plug connection, 22 mm	-	8.0	-10°C to +50°C	-	IP65	-	459
XS03	24.0	Coil for DIN plug connection, 32 mm	-	9.0	-40°C to +50°C	-	IP65	-	467
XT09	23.0	Coil for DIN plug connection	-	9.0	-10°C to +50°C	-	IP54	-	464
YB09	20.1	Coil with flying leads, IP67, UL for AC	-	9.0	-10°C to +50°C	●	IP67	-	469
YB12	20.1	Coil with flying leads, IP67	12.0	-	-10°C to +50°C	-	IP67	-	469
ZB09	20.0	Coil for DIN plug connection, UL for AC	-	9.0	-10°C to +50°C	●	IP65	-	460
ZB12	20.0	Coil for DIN plug connection	12.0	-	-10°C to +50°C	-	IP65	-	460
ZB14	20.2	Coil for DIN plug connection, high power - high temperature series	-	14.0	-10°C to +50°C	-	IP65	-	461
ZB16	20.2	Coil for DIN plug connection, high power - high temperature series	16.0	-	-10°C to +50°C	-	IP65	-	461
ZH14	20.2	Coil for DIN plug connection, high power - high temperature series	-	14.0	-10°C to +80°C	-	IP65	-	461
ZH16	20.2	Coil for DIN plug connection, high power - high temperature series	16.0	-	-10°C to +80°C	-	IP65	-	461

INDEX BY COIL GROUP

Coil Group	Coil Reference	Designation	Power DC Pn (W)	Power AC Pn (W)	Ambient Temperature	UL	Degree of Protection	ATEX or NEIMA 4X Protection (Gas)	Page
1.1	488980	Coil for DIN plug connection, low power, 22 mm	2.5	2.0	-40°C to +50°C	-	IP65	-	453
1.1	492912	Coil for DIN plug connection, UL 22 mm	4.0	3.0	-40°C to +50°C	●	IP65	-	454
1.1	481180	Coil for DIN plug connection, 22 mm	5.0	4.0	-40°C to +50°C	-	IP65	-	453
1.1	488143	Coil for DIN plug connection, double frequency, 22 mm	-	2.5	-40°C to +50°C	-	IP65	-	456
1.1	483590	Coil for DIN plug connection, double frequency, 22 mm	-	3.0	-40°C to +50°C	-	IP65	-	455
1.1	495865	Explosion proof electrical part "nAc nCc", low power, 22 mm	2.5	2.0	-40°C to +50°C	-	IP65	II 3 G Ex nAc nCc IIC T5	484
1.1	482606	Explosion proof encapsulated electrical part "mb", low power, 32 mm	2.5	2.0	-40°C to +65°C	-	IP65	II 2 G Ex mb IIC T4/T5	494
1.1	482605	Explosion proof encapsulated electrical part "mb", 32 mm	5.0	4.0	-40°C to +65°C	-	IP65	II 2 G Ex mb IIC T4/T5	494
1.2	496131	Coil for DIN plug connection, double frequency, 22 mm	3.0	3.0	-40°C to +50°C	-	IP65	-	457
1.2	496482	Coil for DIN plug connection, double frequency coil, 22 mm	3.0	3.0	-40°C to +50°C	-	IP65	-	458
1.2	496637	Explosion proof electrical part "nAc nCc", 22 mm, double frequency	3.0	3.0	-20°C to +50°C	-	IP65	II 3 D Ex tc IIC T 95°C	485
1.3	WB5.0	Coil for DIN plug connection, 22 mm	5.0	-	-10°C to +50°C	-	IP65	-	459
1.3	WB5.0 cURus	Coil for DIN plug connection, 22 mm	5.0	-	-10°C to +50°C	●	IP65	-	459
1.3	WB4.5	Coil for DIN plug connection, 22 mm	-	4.5	-10°C to +50°C	-	IP65	-	459
1.3	WB4.5 UR	Coil for DIN plug connection, 22 mm	-	4.5	-10°C to +50°C	●	IP65	-	459
1.3	WB8.0	Coil for DIN plug connection, 22 mm	-	8.0	-10°C to +50°C	-	IP65	-	459
2.0/2.1	481000	Coil with screw terminal, 40 mm	8.0	8.0	-40°C to +50°C	-	IP 44 to 67	-	474
2.0/2.1	485100	Coil with screw terminal, high temperature, 40 mm	8.0	8.0	-40°C to +50°C	-	IP 44 to 67	-	476
2.0/2.1	481865	Coil for DIN plug connection, 32 mm	9.0	8.0	-40°C to +50°C	-	IP65	-	446
2.0/2.1	492453	Coil for DIN plug connection, high temperature, 32 mm	9.0	8.0	-40°C to +50°C	-	IP65	-	447
2.0/2.1	496081	Coil with flying leads, IP 67, 32 mm	9.0	9.0	-10°C to +50°C	-	IP67	-	472
2.0/2.1	483510	Coil for DIN plug connection, 32 mm	-	9.0	-40°C to +50°C	-	IP65	-	446
2.0/2.1	483520	Coil with screw terminal, double frequency, 40 mm	-	9.0	-40°C to +50°C	-	IP 44 to 67	-	474
2.0/2.1	488553	Coil with screw terminal, double frequency, H class, 40 mm	-	9.0	-40°C to +50°C	-	IP 44 to 67	-	479
2.0/2.1	491514	Coil for DIN plug connection, 32 mm, UL	-	11.0	-40°C to +50°C	●	IP65	-	450
2.0/2.1	495870	Explosion proof electrical part "nAc nCc", 32 mm	9.0	8.0	-40°C to +50°C	-	IP65	II 3 G Ex nAc nCc IIC T3/T4	486
2.0/2.1	496110	Explosion proof electrical part "nAc nCc", 32 mm	-	9.0	-40°C to +50°C	-	IP65	II 3 G Ex nAc nCc IIC T3/T4	486
2.0/2.1	492670	Explosion proof encapsulated electrical part "mb", 32 mm	9.0	8.0	-40°C to +50°C	-	IP65	II 2 G Ex mb IIC T4	495
2.0/2.1	492070	Explosion proof encapsulated electrical part "mb", with water proof metal housing, 50 mm	8.0	9.0	-40°C to +65°C	-	IP67	II 2 G Ex mb IIC T4/T5	496
2.0/2.1	493640	Flame proof encapsulated electrical part "db mb", double frequency	8.0	8.0	-40°C to +75°C	-	IP65	II 2 G Ex db mb IIC T4/T5	503
2.0/2.1	495905	Flame proof encapsulated electrical part "db mb", 37 mm	8.0	8.0	-40°C to +65°C	-	IP67	II 2 G Ex db mb IIC T4	500
2.0/2.1	494040	Explosion proof increased safety electrical part "eb", 50 mm	8.0	8.0	-40°C to +90°C	-	IP67	II 2 G Ex eb IIC T3/T4	504
2.0/2.1	483371	Explosion proof increased safety electrical part "eb", 50 mm	8.0	8.0	-40°C to +65°C	-	IP67	II 2 G Ex eb IIC T4	504
2.0/2.1	492190	Explosion proof increased safety and encapsulated electrical part "eb", 50 mm	9.0	11.0	-40°C to +75°C	-	IP66	II 2 G Ex eb mb IIC T3/T4	507
2.0/2.1	HZ10	Explosion proof encapsulated electrical part "mb", double frequency	8.0	8.0	-40°C to +85°C	-	IP65	II 2 G Ex mb IIC T3/T4/T5	497
2.0/2.2	486265	Coil with screw terminal, high temperature-high power, 40 mm	14.0	14.0	-40°C to +50°C	-	IP 44 to 67	-	476
2.0/2.2	492425	Coil for DIN plug connection, high temperature, 32 mm	14.0	14.0	-40°C to +50°C	-	IP65	-	447
2.0/2.2	481044	Coil with screw terminal High power, 40 mm	-	14.0	-40°C to +50°C	-	IP 44 to 67	-	475
2.0/2.2	495880	Explosion proof electrical part "nAc nCc", 32 mm	14.0	14.0	-40°C to +50°C	-	IP65	II 3 G Ex nAc nCc IIC T3	489
2.0/2.2	496082	Coil with flying leads, IP 67, 32 mm, UL	16.0	13.0-14.0	-40°C to +120°C	●	IP67	-	473
2.0/2.2	496155	Explosion proof increased safety electrical part "nAc nCc", 50 mm	14.0	14.0	-40°C to +65°C	-	IP67	II 3 G Ex nAc nCc IIC T3	491
2.0/2.2	HZ11	Explosion proof encapsulated electrical part "mb", double frequency	14.0	14.0	-40°C to +85°C	-	IP65	II 2 G Ex mb IIC T3/T4/T5	498
2.2	483816	Coil for DIN plug connection for Jet Valves, 32 mm	14.0	14.0	-40°C to +50°C	-	IP65	-	452
3.0	482730	Coil for DIN plug connection, reduced power, 32 mm	7.0	6.0	-40°C to +50°C	-	IP65	-	448
3.0	495875	Explosion proof electrical part "nAc nCc", 32 mm	7.0	6.0	-40°C to +50°C	-	IP65	II 3 G Ex nAc nCc IIC T3/T4	488
4.0	485400	Coil with screw terminal, bistable, for impulse applications, 40 mm	13.0	-	-40°C to +50°C	-	IP44	-	480
4.0	484990	Coil with screw terminal, bistable, for impulse applications, 40 mm	-	11.0	-40°C to +50°C	-	IP44	-	480
4.0	495915	Explosion proof increased safety electrical part "nAc nCc", 50 mm	13.0	11.0	-40°C to +65°C	-	IP67	II 3 G Ex nAc nCc IIC T3	490

INDEX BY COIL GROUP

Coil Group	Coil Reference	Designation	Power DC Pn (W)	Power AC Pn (W)	Ambient Temperature	UL	Degree of Protection	ATEX or NEMA 4X Protection (Gas)	Page
6.0	482740	Coil for DIN plug connection, low power, 32 mm	1.6	-	-40°C to +50°C	-	IP65	-	449
6.0	496125	Explosion proof electrical part "nAc nCc", low power, 32 mm	1.6	-	-40°C to +50°C	-	IP65	II 3 G Ex nAc nCc IIC T5/T6	487
6.0	495900	Flame proof encapsulated electrical part "db mb", low power, 37 mm	2.0	2.5	-40°C to +65°C	-	IP67	II 2 G Ex db mb IIC T4 / T5/T6	499
7.0	483580.01	Explosion proof intrinsically safe electrical part "ia", 32 mm	3.0	-	-40°C to +55°C	-	IP65	II 1 G Ex ia IIC T6	508
7.0	488660.01	Explosion proof intrinsically safe electrical part "ia", 50 mm	3.0	-	-40°C to +65°C	-	IP67	II 1 G Ex ia IIC T6	514
7.0	488650.01	Explosion proof intrinsically safe electrical part "ia", 50 mm	0.3 to 3.0	-	-40°C to +65°C	-	IP66	II 1 G Ex ia IIC T6	513
7.0	488670.01	Explosion proof intrinsically safe electrical part "ia", 50 mm	0.3 to 3.0	-	-40°C to +65°C	-	IP65	II 1 G Ex ia IIC T6	515
7.0	490885	Explosion proof intrinsically safe electrical part, "NEMA", 50 mm	3.0	-	-40°C to +60°C	-	NEMA 4 - 4X	Cl. I, Div.I, Gr. A, B, C, D	513
7.0	490890	Explosion proof intrinsically safe electrical part, "NEMA", 50 mm	3.0	-	-40°C to +60°C	-	NEMA 4 - 4X	Cl. I, Div.I, Gr. A, B, C, D	514
8.0	495910	Explosion proof intrinsically safe electrical part "ia", "booster", 37 mm	0.3 to 1.2.0	-	-40°C to +80°C	-	IP67	II 1 G Ex ia IIC T4/T5/T6	509
9.0	492210	Explosion proof increased safety and encapsulated electrical part "eb", " Booster", 50 mm	1.0 to 1.8	-	-40°C to +75°C	-	IP66	II 2 G Ex eb mb IIC T5/T6	506
9.0	496565	Explosion proof intrinsically safe electrical part "ia", " Booster", 37 mm	0.77 to 2.58	-	-40°C to +80°C	-	IP67	II 1 G Ex ia IIC T4/T5/T6	510
9.0	492965.01	Explosion proof intrinsically safe electrical part "ia", " Booster", 50 mm	0.3 to 2.3	-	-40°C to +65°C	-	IP66	II 1 G Ex ia IIC T6	511
10.1	496895	Coil for DIN plug connection for oil and gas, 37 mm	8.0	8.0	-40°C to +50°C	-	IP65	-	468
10.1	496560	Flame proof encapsulated electrical part "db mb", 37 mm	8.0	8.0	-40°C to +65°C	-	IP67	II 2 G Ex db mb IIC T4	501
10.1	496800	Flame proof encapsulated electrical part "db mb", 37 mm	8.0	8.0	-40°C to +65°C	-	IP67	II 2 G Ex db mb IIC T4	502
10.1	492310	Explosion proof increased safety and encapsulated electrical part "eb", 50 mm	6.0	6.0	-40°C to +75°C	-	IP66	II 2 GD Ex eb mb II T4/T5	505
10.2	496555	Flame proof encapsulated electrical part "db mb", 37 mm	6.0	6.0	-40°C to +65°C	-	IP67	II 2 G Ex db mb IIC T4/T5/T6	501
10.2	496700	Flame proof encapsulated electrical part "db mb", 37 mm	6.0	6.0	-40°C to +65°C	-	IP67	II 2 G Ex db mb IIC T4/T5/T6	502
10.3	497105	Flame proof electrical part "d"	8.0	8.0	-50°C to +80°C	-	IP66	II 2 G Ex db IIC T4/T5/T6	493
11.0	483270	Flame proof electrical part "db", 50 mm	8.0	8.0	-40°C to +80°C	-	IP66	II 2 G Ex db IIC T4/T5/T6	492
12.0	482870.01	Explosion proof intrinsically safe electrical part "ia", 50 mm	3.0	-	-40°C to +65°C	-	IP66	II 1 G Ex ia IIC T6	512
12.0	492335	Explosion proof intrinsically safe electrical part, "NEMA", 50 mm	3.0	-	-40°C to +60°C	-	NEMA 4 - 4X	Cl. I, Div.I, Gr. A, B, C, D	512
13.0	495294	Coil with ISO-DIN connector, 12-24VDC for transportation applications, 32 mm	9.0	-	-40°C to +120°C	-	IP69K	-	481
13.0	496193	Coil with ISO-DIN connector, 12-24VDC for transportation applications, 32 mm	9.0	-	-40°C to +120°C	-	IP69K	-	481
14.1	483824	Coil with screw terminal, high temperature-high power, 40 mm	19.0	19.0	-40°C to +50°C	-	IP 44 to 67	-	477
14.2	483764	Coil for DIN plug connection, 32 mm, UL	-	9.0	-40°C to +50°C	●	IP65	-	451
14.3	483541	Coil with screw terminal, high temperature-high power, 40 mm	20.0	20.0	-40°C to +50°C	-	IP 44 to 67	-	478
20.0	ZB12	Coil for DIN plug connection	12.0	-	-10°C to +50°C	-	IP65	-	460
20.0	ZB09	Coil for DIN plug connection, UL for AC	-	9.0	-10°C to +50°C	●	IP65	-	460
20.1	YB12	Coil with flying leads, IP67	12.0	-	-10°C to +50°C	-	IP67	-	469
20.1	YB09	Coil with flying leads, IP67, UL for AC	-	9.0	-10°C to +50°C	●	IP67	-	469
20.2	ZB16	Coil for DIN plug connection, high power -high temperature series	16.0	-	-10°C to +50°C	-	IP65	-	461
20.2	ZH16	Coil for DIN plug connection, high power -high temperature series	16.0	-	-10°C to +80°C	-	IP65	-	461
20.2	ZB14	Coil for DIN plug connection, high power -high temperature series	-	14.0	-10°C to +50°C	-	IP65	-	461
20.2	ZH14	Coil for DIN plug connection, high power -high temperature series	-	14.0	-10°C to +80°C	-	IP65	-	461
21.0	JB14	Coil for DIN plug connection	16.0	-	-10°C to +50°C	-	IP65	-	462
21.0	JB16	Coil for DIN plug connection	-	14.0	-10°C to +50°C	-	IP65	-	462
22.0	KT10	Coil for DIN plug connection	10.0	-	-10°C to +50°C	-	IP65	-	463
22.0	KH09	Coil for DIN plug connection	-	9.0	-10°C to +80°C	-	IP65	-	463
22.0	KT09	Coil for DIN plug connection	-	9.0	-10°C to +50°C	-	IP65	-	463
23.0	XT09	Coil for DIN plug connection	-	9.0	-10°C to +50°C	-	IP54	-	464
24.0	D5	Coil for DIN plug connection, 32 mm	9.0	8.0	-40°C to +50°C	-	IP65	-	466
24.0	LA	Coil with flying leads, IP67, 32 mm	9.0	9.0	-10°C to +50°C	-	IP67	-	470
24.0	D4	Coil for DIN plug connection, 32 mm, UL	16.0	13.0	-40°C to +50°C	●	IP65	-	465
24.0	LB-LC	Coil with flying leads, IP 67, 32 mm, UL	16.0	13.0-14.0	-10°C to +50°C	●	IP67	-	471
24.0	XS03	Coil for DIN plug connection, 32 mm	-	9.0	-40°C to +50°C	-	IP65	-	467

INDEX BY VALVE REFERENCE

Valve Order Number	Page	Valve Order Number	Page	Valve Order Number	Page	Valve Order Number	Page
360451J	186	363570	38	390525	180	392396	82
360452J	186	364010	182	390560	180	392408	82
360469	90	364035	182	390580	180	392409	82
360470	126	364520	134	390605	180	397146J	90
360475	126	364530	136	390625	180	398000	28
360479J	226	364535	136	390626	180	398001	28
360480J	226	364880J	126	390650	182	398003	28
360490J	226	364884J	126	390668	180	398006	30
360506	226	366501	54	390700	180	398007	30
361810	46	366511	54	390705	182	398008	30
361850	46	366521	54	390718	182	398010	30
361910	46	366531	54	390720	182	398012	30
361950	46	366601	68	390721	182	398013	28
362262	134	366606	68	390725	180	398014	28
362263	134	366611	68	390802	180	398016	28
362264	136	366616	68	390803	180	398017	28
362265	136	366770	54	390805	180	398018	28
362290	38	366775	54	390813	180	398022	28
362410J	220	390005	178	390874	180	398024	28
362460J	220	390034	178	390875	180	398026	28
362470J	220	390085	178	390878	180	398030	28
362475J	220	390086	178	390895	180	398034	28
362496J	126, 178	390088	178	390915	180	398052	28
362510J	180	390089	178	390945	180	398100	208
362518J	126, 180	390120	178	390975	180	398102	208
362524J	126, 180	390145	178	390995	180	398104	208
362530J	180	390150	178	390997	180	398112	208
362560J	208	390165	178	392169	82	398114	208
362570J	208	390195	178	392170	82	398120	208
362620J	208	390215	178	392173	82	398122	208
362630J	208	390216	178	392335	80	398130U	208
363282	38	390300	178	392349	80	398132	208
363378	28, 80	390405	178	392355	80	398134U	208
363380	28, 30	390445	178	392366	80	398136U	208
363390	30, 80	390457	178	392370	80	398138	208
363444	30, 82	390458	178	392372	80	398142	208
363457	30, 82	390465	178	392388	80	443776W	94
363467	30, 82	390495	178	392389	80	443777W	94
363475	38	390505	178	392395	82	443778W	94

INDEX BY VALVE REFERENCE

<u>Valve Order Number</u>	<u>Page</u>	<u>Valve Order Number</u>	<u>Page</u>	<u>Valve Order Number</u>	<u>Page</u>
443779W	94	443796W	116	444494W	94
443780W	94	443797W	96	444497W	94
443781W	94	443798W	96	444499W	106
443782W	94	443799W	96	444500W	106
443783W	94	443800W	116	444501W	106
443784W	116	443801W	96	444502W	106
443785W	94	443802W	116	444503W	106
443786W	94	443803W	116	444513W	106
443787W	94	443804W	94	444576W	106
443788W	116	443805W	106	444600W	106
443789W	94	443806W	106	444601W	106
443790W	96	443807W	106	444602W	106
443791W	96	443808W	106	444603W	106
443792W	116	443809W	106	444604W	106
443793W	96	443810W	106	444605W	106
443794W	96	443811W	106		
443795W	96	444492W	94		

INDEX FOR VALVES

Valve Reference	Page	Valve Reference	Page	Valve Reference	Page	Valve Reference	Page
U 033X0111	330	121K2423	184	122V8306	162	E 131K0358	210,302
U 033X5152	400	121K3106	36,86,144	PM 123AV	46	131K0397	210,214
U 033X5156	400	121K3206	36,86,144	PM 123CV	46	E 131K04	212,304
U 033X51561D	400	121K3303	128	PM 123DV	46	E 131K0450	212,304
U 033X5195	402	121K3306	36,86,144	PM 123IV	46	131K0490	210,302
U 033X5256	404	121K3321	184	PM 125BV	90	131K0497	212,304
U 033X52561D	404	E 121K45	36,86	PM 125CV.2	90	E 131K06	214,304
U 033X7156	402	E 121K4503	128	125K01	40,88	131K0648	272
PM 120.4AR	186	E 121K46	36,86	125K03	40	E 131K0650	214,304
PM 120.4IR	186	E 121K4603	128	PM 126YH	126	E 131K13	210
121F2523	188	121K6220	184	PM 126YT	126	E 131K14	210
E 121F43	42,146	E 121K63	34,142	PM 128GR	226	131K16	210
E 121F4302	42,92	E 121K64	34,144	PM 128IR	226	131K1650	210
121F4317	42	121K6423	184	PM 128ISV	226	E 131K63	216
E 121F44	42,146	E 121K65	32,142	PM 128IV	226	E 131K6350	216
E 121F4406	42,92	E 121K67	32,142	131.4BV	178	E 131K64	212
121F4417	42	121M13	32,84	131.4CG	180	E 131K6450	212
121F47	42	121M14	32,84	131.4FV	180	131M14	210,302
121F4706	42,146	121V5106	160	131.4GG	180	131M15	210,302
121F63	42,146	121V5112	160	131.4GV	180,182	131M74	228
121F64	42,146	121V5163	130,160	131AN	178	131M7450	228
121F67	42,146	121V5206	160	131B04	234	131M75	228
121G2320	184	121V5212	160	131B14	234	131M7550	228
121G2520	184	121V5263	130,160	E 131E03	216,306	131T21	216
121G2523	184	121V5306	158	E 131F26	238	131T2101	306
121K01	34,84	121V5363	130,158	E 131F43	230	131T22	216
121K0103	128	121V5397	160	E 131F4350	230	131T23	212
121K0106	34,84	121V5406	158	131F4397	312	131T2301	212
121K0113	128	121V5463	130,158	E 131F44	230	131T29	214
121K0150	34,84	121V5497	158	131F4410	228	131T2901	214
121K02	34,84	U 121V5595	170	E 131F4450	230	131V5306	252
121K0250	34,84	U 121V5596	170	131F4490	228	131V5363	252
E 121K03	34,142,144	U 121V55961D	170	131F4497	228	131V5397	252
E 121K0302	34,84	121V5706	158	131F46	230	131V5406	252
121K0323	128	121V5763	130,158	131F4650	230	131V5463	252
E 121K0352	34,84	122F44	44	U 131F5295	384	131V5490	252
121K0397	34	122K83	40	131F5406	236	131V5497	252
E 121K04	32,142	122K8306	40,86	U 131F5695	384	131X1101	334
E 121K0402	32,84	122K8321	188	U 131F56951D	384	U 131X1101	334
121K0497	32	122K8363	40,144	131IN	178	131X1131	334
E 121K07	32	122K84	40,144	131INDIN	178	U 131X1201	386
121K0706	32,84	122K8406	40	131IV	178	132F43	230
121K1302	32	122K8408	40,144	E 131K03	216	132F44	230
E 121K14	32,142	122K9321	188	E 131K0308	216,306	132F46	230
E 121K23	32,142	122K9363	40,144	E 131K0350	216,306	132K03	218

INDEX FOR VALVES

Valve Reference	Page	Valve Reference	Page	Valve Reference	Page	Valve Reference	Page
132K04	218	U 133X5192	378	PM 156.2IR	134	221G1630	50
132K06	218	U 133X5195	384	PM 158IH	126	221G1631	50
132T22	218	U 133X51951D	386	PM 158IT	126	221G17	52
132T23	218	U 133X5196	378	161.4AV	80	221G1703	132
132T2301	218	U 133X51961D	380	161.4BV	80	221G1710	52
132T29	308	U 133X5296	382	161.4EV	82	221G1730	52
E 133F43	232	U 133X52961D	382	PM 168.1AN	54	221G1731	114
E 133F44	232	U 133X7156	380	PM 168.1CN	54	221G21	52
E 133F4450	232	U 133X7195	386	PM 168.1DN	54	221G2103	114
133F46	232	U 133X7196	380	PM 168.1IN	54	221G2106	52
133F4650	312	PM 135AT	134	PM 169.1AN	68	221G2110	52
E 133K03	222	PM 135CT	136	PM 169.1CN	68	221G2130	52
E 133K0350	222	PM 135DT	136	PM 169.1DN	68	221G2131	114
E 133K04	222	PM 135IT	134	PM 169.1IN	68	221G2136	52
E 133K0450	222	135K03	310	PM 173AN	54	221G23	48
133K0497	222	135K04	224	PM 173IN	54	221G2330	48
E 133K05	222	PM 136.2FV	38	2019F1GRG7	202	221G25	48
E 133K06	222	PM 136VY	38	2019F1GVG7	202	221G2523	190
E 133K0650	222	PM 139AV	220	2019F1JRG7	202	221G2530	48
E 133K13	222	PM 139FV	220	2019F1JVG7	202	221G26	50
E 133K14	222	PM 139GV	220	2019F1LRG7	202,204	221G2630	50
E 133K16	222	PM 139LV	220	2019F1LVG7	204	221G27	52
133T21	222	PM 140.4AR	180	2019F1NRG7	204	221G2730	52
133T2101	224	PM 140.4DR	180	2019F1NVG7	204	221J3301E	198
133T23	222	PM 140CR	126,180	201LG1GVG2	166	221S10E	172
133T2301	222	PM 140DR	126,180	201LG1JVG2	166	221S10F	172
133V5306	254	PM 140IR	126,178	201LG1LVG2	166	221S15E	172
133V5363	254	PM 141AV	208	201LG2GVG2	166	221S15F	172
133V5406	254	PM 141BV	208	201LG2JVG2	166	221S20E	172
133V5463	254	PM 141FV	208	201LG2LVG2	166	221S20F	172
U 133V5595	376	PM 141GV	208	201LG2NVG7	166	221S25E	174
U 133V55951D	376	PM 146.3ABV	30,82	201LG2PVG7	166	221S25F	174
U 133V5695	376	PM 146.3KV	30,82	201LG3SVG7	168	3019F1GRG7	258
U 133V56951D	376	PM 146BV	28,80	201LG3UVG7	168	3019F1GVG7	258
U 133V7595	376	PM 146FV	28,30,80	201LG4SVG7	168	3019F1JRG7	258,260
U 133V7695	376	PM 146HV	30,80	201LG4UVG7	168	3019F1JVG7	260
133X01	314	PM 146WV	30,82	221G13	48	3019F1LRG7	260
U 133X01	314	PM 146VY	30,82	221G1303	132	3019F1LVG7	260
133X01001D	314	PM 151GV	38	221G1330	132	3019F1NRG7	262
U 133X0111	308	PM 151HV	38	221G15	48	3019F1NVG7	262
U 133X01111D	308	PM 153BV	182	221G1503	132	301XGFRTG7	258
U 133X0131	310	PM 153GV	182	221G1530	48	301XGFRTJ7	260
U 133X5152	378	PM 156.2AR	134	221G16	50	301XGFRTL7	260
U 133X5156	378	PM 156.2CR	136	221G1603	132	301XGFRTN7	262
U 133X51561D	378	PM 156.2DR	136	221G1610	50	301XGFVTG7	258

INDEX FOR VALVES

Valve Reference	Page	Valve Reference	Page	Valve Reference	Page	Valve Reference	Page
301XGFVTJ7	260	321K1536	268	322H35	70	341L0197	294
301XGFVTL7	260,262	321K1537	268	322H36	72	E 341L02	292
301XGFVTN7	262	321K1543	266	322H71	70	341L04	294
321F2523	194	E 321K25	60,100	322H7106	70,152	341L05	294
E 321F32	76,110	321K31	56,98	322H73	70,152	341L11	290
E 321F3202	76,154	321K3106	56	322H7306	70,152	E 341L1130	290
321F35	76	321K33	58,98	322H75	70,152	U 341L1130	290
E 321G36	62,102	321K3306	58	322H7506	70,152	E 341L21	286
E 321G3606	62	321K35	60,100	322K4106	108	341L2190	286
E 321G3610	118	321K3506	60	322K4306	108	341L9101	282
E 321G37	64,104	321K36	62,102	322K4506	108	341L9201	286
E 321G3706	64	321K3606	62	322K4606	108	341L9504	362
E 321G3710	120	321K37	64,104	322K4706	110	341L9534	362
321G3790	64	321K3706	64	325K4106	74	341L9594	364
E 321G38	64,104	321K4106	98,118	325K4306	74	341L9597	364
E 321G3806	64	321K4156	56	325K4506	74	341L9598	364
E 321G3810	120	321K4306	98,118	325K4606	74	341N01	340
E 321G39	66,104	321K4356	58	325K4706	74	341N02	346
E 321G3906	66	321K4506	100,118	E 331B01	240	U 341N0250	396
E 321G3910	120	321K4556	100,118	331B02	248	341N03	350
321G3990	66	321K4606	102,118	331B0216	248	341N04	350
E 321G40	66,104	321K4656	102,118	E 331B21	242	341N05	344
E 321G4006	66	321K4706	104,120	E 331B74	240	341N0502	346
E 321G4010	120	321K4756	104,120	331B7490	240	341N11	340
321G4090	66	E 321K63	148	E 331L21	244	341N12	348
E 321H11	56,148	322F35	76	331N03	336	341N21	340
E 321H13	58,148	322F72	76	331N04	336	341N2190	340
E 321H15	60,150	322F7206	76,154	331N0402	336	341N22	348
321H1590	60	322G36	72,108	331N34	338	341N31	342
E 321H21	148,192	322G3606	72	331N3402	338	341N3102	342
E 321H23	148,192	322G3610	122	E 332B01	242	341N3108	342
321H2322	192	322G37	72,110	332B02	242	341N3128	342
E 321H25	150,194	322G3706	72	E 332B21	244	341N3130	342
321H2522	194	322G3710	122	E 341B01	278	341N3190	342
321H2523	194	322G38	72	341B02	276	341N3196	342
321H35	60	322G3806	72	E 341B21	278	341N3197	342
321H36	62	322G3810	122	341B34	276	341N32	348
E 321K10	56,98	322G39	72,110	341B3403	276	341N3202	348
E 321K13	58,98	322G3906	72	341B3440	276	U 341N3250	394
E 321K1314	58,98	322G3910	122	341B3490	276	341N3290	344
E 321K15	60,100	322G40	72	E 341F21	278	U 341N3292	394
E 321K1503	138	322G4006	72	341F34	284	U 341N3295	394
E 321K1514	60,100	322G4010	122	341F3403	284	341N3296	344
321K1523	268	322G75	70,108	341F3440	284	341N3297	344
321K1535	266	322G7506	70,152	E 341L01	294	341N34	350

INDEX FOR VALVES

Valve Reference	Page	Valve Reference	Page	Valve Reference	Page	Valve Reference	Page
341N35	346	E 347L1130	292	541N04	370	7321BMN02	116
341N3502	346	347L9101	282	542N03	372	7322BAH00	106
341P01	316	347L9201	288	547N03	370	7322BAN00	106
341P02	318	347N03	354	7321BAH00	94	7322BAV00	106
U 341P0250	388	347N04	356	7321BAN00	94	7322BCH00	106
341P03	318	347N11	352	7321BAN01	94	7322BCN00	106
341P04	322	347N12	354	7321BAV00	94	7322BCV00	106
341P21	316	347N31	352	7321BCH00	94	7322BDH00	106
341P2108	316	347N3190	352	7321BCN00	94	7322BDN00	106
341P2190	318	347N3197	352	7321BCN01	94	7322BDV00	106
341P2197	316	347N32	354	7321BCN02	116	7322BEH00	106
341P22	320	U 347N3250	398	7321BCV00	94	7322BEN00	106
341P2290	320	347N33	354	7321BDH00	94	7322BFH00	106
341P2297	320	347N34	356	7321BDN00	94	7322BFN00	106
U 341P3250	388	347P01	324	7321BDN01	94	7322BGH00	106
U 341P3292	390	347P02	326	7321BDN02	116	7322BGN00	106
341P3295	390	347P03	326	7321BDV00	94	7322BIH00	106
341P33	318	347P04	328	7321BEH00	96	7322BIN00	106
341P34	322	347P21	324	7321BEN00	96	7322BIV00	106
342N03	358	347P2190	324	7321BEN01	96	7322BLN06	106
342N11	358	347P2197	324	7321BEN02	116	7322BMN06	106
342N3197	358	347P22	326	7321BFH00	96	N74.4AV	28
342N33	358	U 347P3250	392	7321BFN00	96	N74.4AVA.5	28
343N03	360	U 347P3295	392	7321BFN01	96	N74.4FV	28
345B04	280	347P33	326	7321BFN02	116	N74.4IV	28
345B24	280	347P34	328	7321BGH00	96	N74.4WV	30
345B34	280	421F35	76	7321BGN00	96	N79.4AV	208
345F34	284	U 441P3250	388	7321BGN01	96	N79.4IV	208
345L01	296	531N03	366	7321BGN02	116	N79.6AV	208
345L21	288	541N04	366	7321BIH00	94	N79.6BV	208
345N31	362	541L01	298	7321BIN00	94		
345P21	328	541N01	368	7321BIN01	94		
347L04	288	541N0108	368	7321BIV00	94		
347L11	292	541N03	370	7321BLN02	116		

**WARNING - USER RESPONSIBILITY**

FAILURE OR IMPROPER SELECTION OR IMPROPER USE OF THE PRODUCTS DESCRIBED HEREIN OR RELATED ITEMS CAN CAUSE DEATH, PERSONAL INJURY AND PROPERTY DAMAGE.

- This document and other information from Parker-Hannifin Corporation, its subsidiaries and authorized distributors provide product or system options for further investigation by users having technical expertise.
- The user, through its own analysis and testing, is solely responsible for making the final selection of the system and components and assuring that all performance, endurance, maintenance, safety and warning requirements of the application are met. The user must analyze all aspects of the application, follow applicable industry standards, and follow the information concerning the product in the current product catalog and in any other materials provided from Parker or its subsidiaries or authorized distributors.
- To the extent that Parker or its subsidiaries or authorized distributors provide component or system options based upon data or specifications provided by the user, the user is responsible for determining that such data and specifications are suitable and sufficient for all applications and reasonably foreseeable uses of the components or systems.

Parker's Motion & Control Technologies

At Parker, we're guided by a relentless drive to help our customers become more productive and achieve higher levels of profitability by engineering the best systems for their requirements. It means looking at customer applications from many angles to find new ways to create value.

Whatever the motion and control technology need, Parker has the experience, breadth of product and global reach to consistently deliver. No company knows more about motion and control technology than Parker.

For further info call
00800 27 27 5374



Aerospace

Key Markets

Aftermarket services
Commercial transports
Engines
General & business aviation
Helicopters
Launch vehicles
Military aircraft
Missiles
Power generation
Regional transports
Unmanned aerial vehicles

Key Products

Control systems & actuation products
Engine systems & components
Fluid conveyance systems & components
Fluid metering, delivery & atomization devices
Fuel systems & components
Fuel tank inerting systems
Hydraulic systems & components
Thermal management
Wheels & brakes



Climate Control

Key Markets

Agriculture
Air conditioning
Construction Machinery
Food & beverage
Industrial machinery
Life sciences
Oil & gas
Precision cooling
Process
Refrigeration
Transportation

Key Products

Accumulators
Advanced actuators
CO₂ controls
Electronic controllers
Filter driers
Hand shut-off valves
Heat exchangers
Hose & fittings
Pressure regulating valves
Refrigerant distributors
Safety relief valves
Smart pumps
Solenoid valves
Thermostatic expansion valves



Hydraulics

Key Markets

Aerial lift
Agriculture
Alternative energy
Construction machinery
Forestry
Industrial machinery
Machine tools
Marine
Material handling
Mining
Oil & gas
Power generation
Refuse vehicles
Renewable energy
Truck hydraulics
Turf equipment

Key Products

Accumulators
Cartridge valves
Electrohydraulic actuators
Human machine interfaces
Hybrid drives
Hydraulic cylinders
Hydraulic motors & pumps
Hydraulic systems
Hydraulic valves & controls
Hydrostatic steering
Integrated hydraulic circuits
Power take-offs
Power units
Rotary actuators
Sensors



Pneumatics

Key Markets

Aerospace
Conveyor & material handling
Factory automation
Life science & medical
Machine tools
Packaging machinery
Transportation & automotive

Key Products

Air preparation
Brass fittings & valves
Manifolds
Pneumatic accessories
Pneumatic actuators & grippers
Pneumatic valves & controls
Quick disconnects
Rotary actuators
Rubber & thermoplastic hose & couplings
Structural extrusions
Thermoplastic tubing & fittings
Vacuum generators, cups & sensors



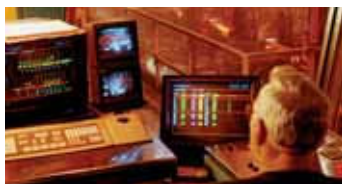

Electromechanical

Key Markets

Aerospace
 Factory automation
 Life science & medical
 Machine tools
 Packaging machinery
 Paper machinery
 Plastics machinery & converting
 Primary metals
 Semiconductor & electronics
 Textile
 Wire & cable

Key Products

AC/DC drives & systems
 Electric actuators, gantry robots & slides
 Electrohydraulic actuation systems
 Electromechanical actuation systems
 Human machine interface
 Linear motors
 Stepper motors, servo motors, drives & controls
 Structural extrusions



Filtration

Key Markets

Aerospace
 Food & beverage
 Industrial plant & equipment
 Life sciences
 Marine
 Mobile equipment
 Oil & gas
 Power generation & renewable energy
 Process
 Transportation
 Water Purification

Key Products

Analytical gas generators
 Compressed air filters & dryers
 Engine air, coolant, fuel & oil filtration systems
 Fluid condition monitoring systems
 Hydraulic & lubrication filters
 Hydrogen, nitrogen & zero air generators
 Instrumentation filters
 Membrane & fiber filters
 Microfiltration
 Sterile air filtration
 Water desalination & purification filters & systems



Fluid & Gas Handling

Key Markets

Aerial lift
 Agriculture
 Bulk chemical handling
 Construction machinery
 Food & beverage
 Fuel & gas delivery
 Industrial machinery
 Life sciences
 Marine
 Mining
 Mobile
 Oil & gas
 Renewable energy
 Transportation

Key Products

Check valves
 Connectors for low pressure fluid conveyance
 Deep sea umbilicals
 Diagnostic equipment
 Hose couplings
 Industrial hose
 Mooring systems & power cables
 PTFE hose & tubing
 Quick couplings
 Rubber & thermoplastic hose
 Tube fittings & adapters
 Tubing & plastic fittings



Process Control

Key Markets

Alternative fuels
 Biopharmaceuticals
 Chemical & refining
 Food & beverage
 Marine & shipbuilding
 Medical & dental
 Microelectronics
 Nuclear Power
 Offshore oil exploration
 Oil & gas
 Pharmaceuticals
 Power generation
 Pulp & paper
 Steel
 Water/wastewater

Key Products

Analytical Instruments
 Analytical sample conditioning products & systems
 Chemical injection fittings & valves
 Fluoropolymer chemical delivery fittings, valves & pumps
 High purity gas delivery fittings, valves, regulators & digital flow controllers
 Industrial mass flow meters/controllers
 Permanent no-weld tube fittings
 Precision industrial regulators & flow controllers
 Process control double block & bleeds
 Process control fittings, valves, regulators & manifold valves



Sealing & Shielding

Key Markets

Aerospace
 Chemical processing
 Consumer
 Fluid power
 General industrial
 Information technology
 Life sciences
 Microelectronics
 Military
 Oil & gas
 Power generation
 Renewable energy
 Telecommunications
 Transportation

Key Products

Dynamic seals
 Elastomeric o-rings
 Electro-medical instrument design & assembly
 EMI shielding
 Extruded & precision-cut, fabricated elastomeric seals
 High temperature metal seals
 Homogeneous & inserted elastomeric shapes
 Medical device fabrication & assembly
 Metal & plastic retained composite seals
 Shielded optical windows
 Silicone tubing & extrusions
 Thermal management
 Vibration dampening

ENGINEERING YOUR SUCCESS.

Parker Worldwide

Europe, Middle East, Africa

AE - United Arab Emirates, Dubai
Tel: +971 4 8127100
parker.me@parker.com

AT - Austria, Wiener Neustadt
Tel: +43 (0)2622 23501-0
parker.austria@parker.com

AT - Eastern Europe, Wiener Neustadt
Tel: +43 (0)2622 23501 900
parker.eastern@parker.com

AZ - Azerbaijan, Baku
Tel: +994 50 2233 458
parker.azerbaijan@parker.com

BE/LU - Belgium, Nivelles
Tel: +32 (0)67 280 900
parker.belgium@parker.com

BY - Belarus, Minsk
Tel: +375 17 209 9399
parker.belarus@parker.com

CH - Switzerland, Etoy
Tel: +41 (0)21 821 87 00
parker.switzerland@parker.com

CZ - Czech Republic, Klecany
Tel: +420 284 083 111
parker.czechrepublic@parker.com

DE - Germany, Kaarst
Tel: +49 (0)2131 4016 0
parker.germany@parker.com

DK - Denmark, Ballerup
Tel: +45 43 56 04 00
parker.denmark@parker.com

ES - Spain, Madrid
Tel: +34 902 330 001
parker.spain@parker.com

FI - Finland, Vantaa
Tel: +358 (0)20 753 2500
parker.finland@parker.com

FR - France, Contamine s/Arve
Tel: +33 (0)4 50 25 80 25
parker.france@parker.com

GR - Greece, Athens
Tel: +30 210 933 6450
parker.greece@parker.com

HU - Hungary, Budapest
Tel: +36 23 885 470
parker.hungary@parker.com

IE - Ireland, Dublin
Tel: +353 (0)1 466 6370
parker.ireland@parker.com

IT - Italy, Corsico (MI)
Tel: +39 02 45 19 21
parker.italy@parker.com

KZ - Kazakhstan, Almaty
Tel: +7 7272 505 800
parker.eastern@parker.com

NL - The Netherlands, Oldenzaal
Tel: +31 (0)541 585 000
parker.nl@parker.com

NO - Norway, Asker
Tel: +47 66 75 34 00
parker.norway@parker.com

PL - Poland, Warsaw
Tel: +48 (0)22 573 24 00
parker.poland@parker.com

PT - Portugal, Leca da Palmeira
Tel: +351 22 999 7360
parker.portugal@parker.com

RO - Romania, Bucharest
Tel: +40 21 252 1382
parker.romania@parker.com

RU - Russia, Moscow
Tel: +7 495 645-2156
parker.russia@parker.com

SE - Sweden, Spånga
Tel: +46 (0)8 59 79 50 00
parker.sweden@parker.com

SK - Slovakia, Banská Bystrica
Tel: +421 484 162 252
parker.slovakia@parker.com

SL - Slovenia, Novo Mesto
Tel: +386 7 337 6650
parker.slovenia@parker.com

TR - Turkey, Istanbul
Tel: +90 216 4997081
parker.turkey@parker.com

UA - Ukraine, Kiev
Tel: +380 44 494 2731
parker.ukraine@parker.com

UK - United Kingdom, Warwick
Tel: +44 (0)1926 317 878
parker.uk@parker.com

ZA - South Africa, Kempton Park
Tel: +27 (0)11 961 0700
parker.southafrica@parker.com

North America

CA - Canada, Milton, Ontario
Tel: +1 905 693 3000

US - USA, Cleveland
Tel: +1 216 896 3000

Asia Pacific

AU - Australia, Castle Hill
Tel: +61 (0)2-9634 7777

CN - China, Shanghai
Tel: +86 21 2899 5000

HK - Hong Kong
Tel: +852 2428 8008

IN - India, Mumbai
Tel: +91 22 6513 7081-85

JP - Japan, Tokyo
Tel: +81 (0)3 6408 3901

KR - South Korea, Seoul
Tel: +82 2 559 0400

MY - Malaysia, Shah Alam
Tel: +60 3 7849 0800

NZ - New Zealand, Mt Wellington
Tel: +64 9 574 1744

SG - Singapore
Tel: +65 6887 6300

TH - Thailand, Bangkok
Tel: +662 186 7000-99

TW - Taiwan, Taipei
Tel: +886 2 2298 8987

South America

AR - Argentina, Buenos Aires
Tel: +54 3327 44 4129

BR - Brazil, Sao Jose dos Campos
Tel: +55 800 727 5374

CL - Chile, Santiago
Tel: +56 2 623 1216

MX - Mexico, Apodaca
Tel: +52 81 8156 6000

EMEA Product Information Centre

Free phone: 00 800 27 27 5374

(from AT, BE, CH, CZ, DE, DK, EE, ES, FI, FR, IE, IL, IS, IT, LU, MT, NL, NO, PL, PT, RU, SE, SK, UK, ZA)

US Product Information Centre

Toll-free number: 1-800-27 27 537

www.parker.com

