

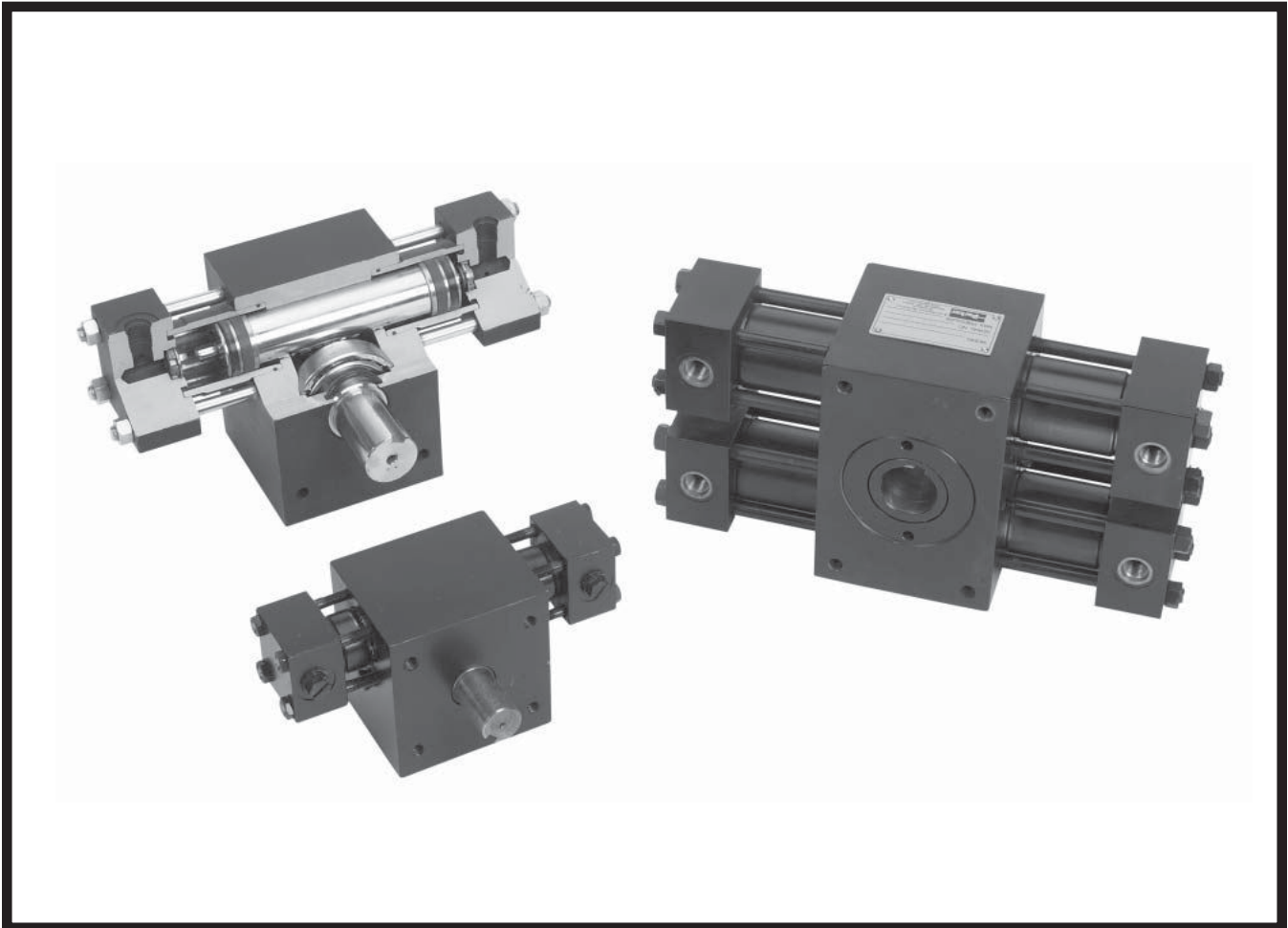

# HTR Series

Hydraulic Rack & Pinion  
Rotary Actuators



## Contents

Features .....	2
Ordering Information .....	3-4
Specifications .....	5-6
Engineering Data .....	6-8
Dimensional Data .....	9-10
Options	
Cushions .....	11
Stroke Adjusters .....	12

## Options (cont)

Mounting .....	13
Shaft .....	14
Port Threads, Port Location .....	15
Seals .....	16
Proximity Sensors .....	17
Feedback Packages .....	17



**RACK & PINION** made from through hardened, high strength alloy steels for long and durable service life in most applications. Option: Case hardening.

**PISTON SEALS**

Depending on actuator size, either dual lip seals made from abrasion resistant polyurethane or heavy duty, deep section Polypak seals made from Molythane for dependable service in most applications. Options: Fluorocarbon seals for certain synthetic fluids; and carboxylated nitrile seals for water based fluids. Piston seals can be inspected and replaced without disconnecting the load from the shaft. (Employ proper safety practices to prevent damage to people or equipment.)

**BRONZE RACK BEARING**

reduces friction, wear and tear between the housing and the rack gear. Replaceable bronze bearing comes standard with HTR15 through HTR600 actuators. High strength bearing material options available.

**WEAR BANDS**

Filled PTFE bands (std) precisely position pistons and prevent side loading from scoring cylinder bores. High strength wear band options available.

**OPTIONAL CUSHIONS**

If properly adjusted, cushions can serve as a braking device for most industrial loads and applications. The proven Parker "floating cushion bushing" serves as a high performance check valve for quick cushion get away and the needle valve can be adjusted to regulate the exhaust flow from the piston. Our design uses no springs or check valve seats that can fatigue or break under normal usage.

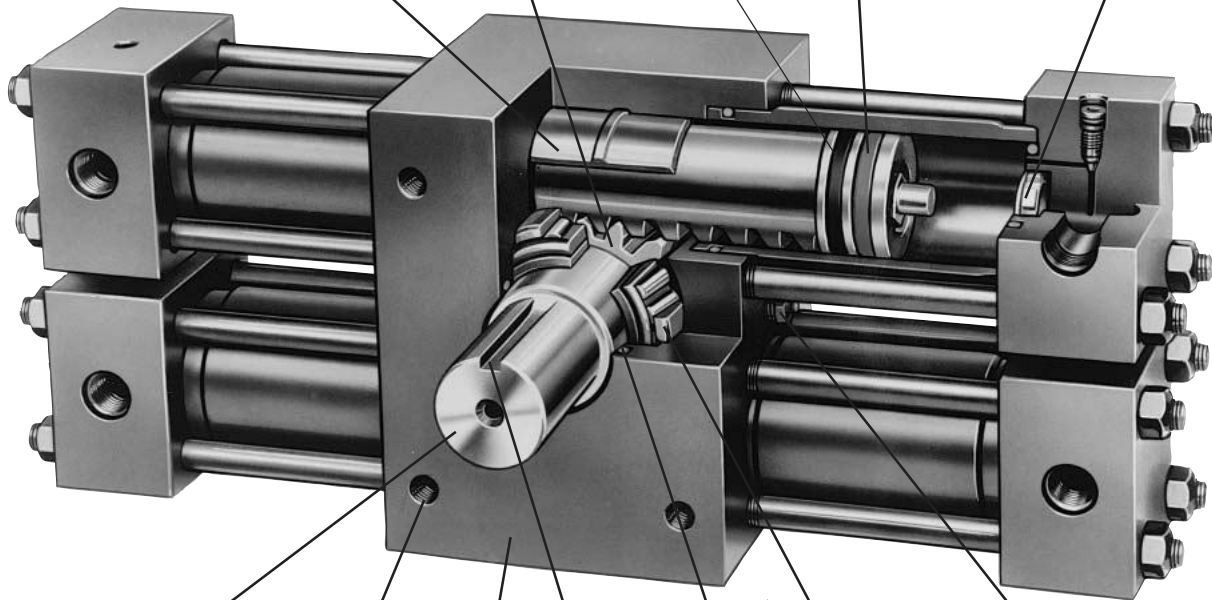

**STANDARD MALE KEYED SHAFT**

is made integral with the pinion gear and is suitable for most applications. Options: double male key, hollow bore keyed and spline shafts are available.

**KEYWAY**

Mid stroke at 12:00 position is standard

**RELIEF VALVE**

is designed to prevent the housing from seeing pressure due to piston seal bypass. Seal kits are available.

**HOUSING**

The heavy, high strength, shock resistant, ductile iron housing serves as a firm base to drive large output torque requirements.

**PISTON SEALS**

Dual lobed seal of abrasion resistant materials seals effectively with minimum wear at dynamic conditions.

**TAPERED ROLLER BEARINGS**

are generously sized to support large external axial and radial loads applied to the shaft.

**THREADED MOUNTING HOLES**

Our standard mounting uses four bolt holes drilled and tapped on the front and back of the housing. Options: additional pilot ring or base mount.

Model Code and Ordering Information

Example: HTR150-1803C-AB11VJ-C

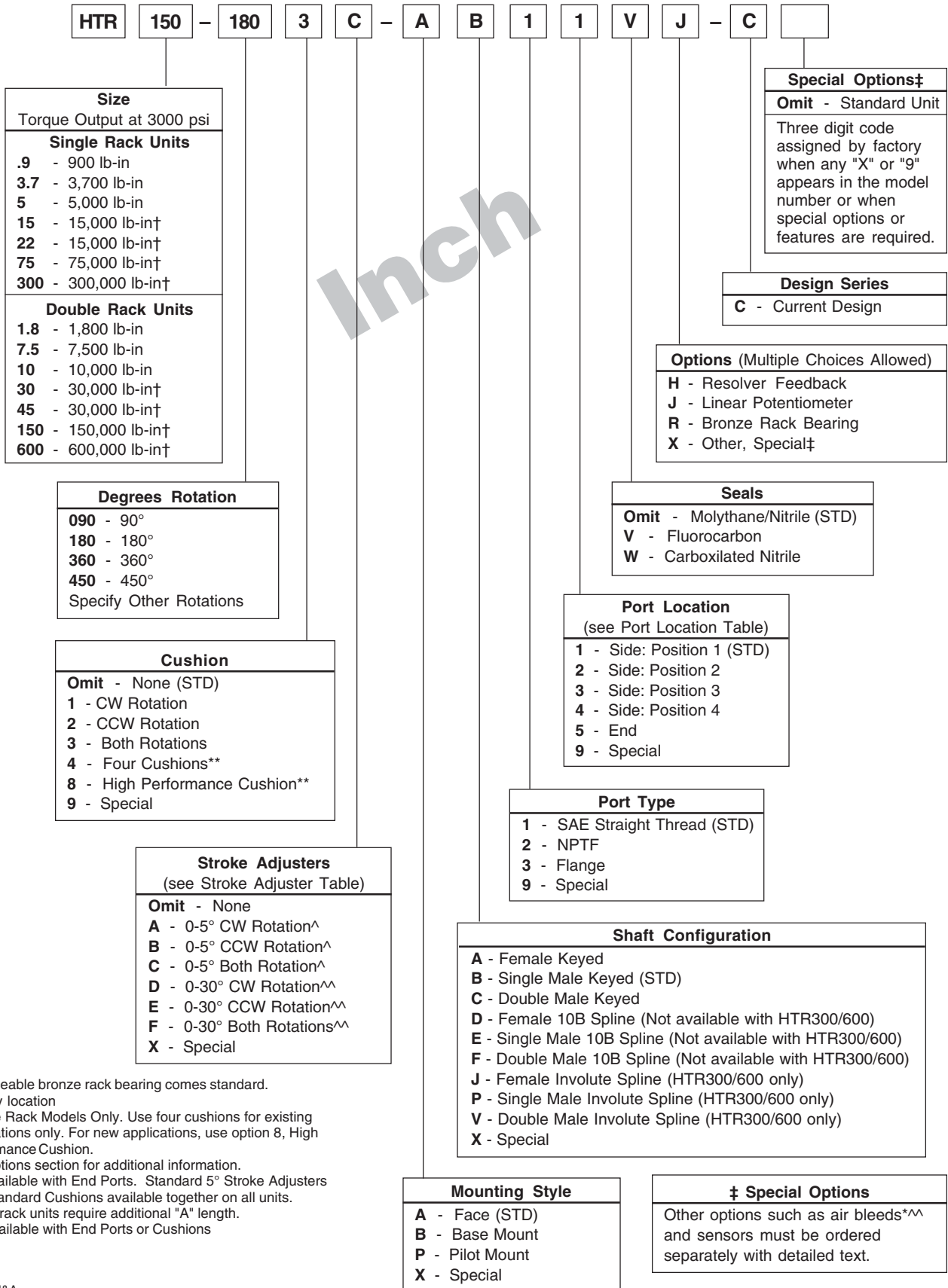

† Replaceable bronze rack bearing comes standard.  
\* Specify location  
\*\* Double Rack Models Only. Use four cushions for existing applications only. For new applications, use option 8, High Performance Cushion.  
See options section for additional information.  
^ Not available with End Ports. Standard 5° Stroke Adjusters and Standard Cushions available together on all units.  
Single rack units require additional "A" length.  
^^ Not Available with End Ports or Cushions

Rack & Pinion Actuators

LTR

HTR

M



Model Code and Ordering Information

Example: HTR150-180C-3-D-G-4-1-V-J-C

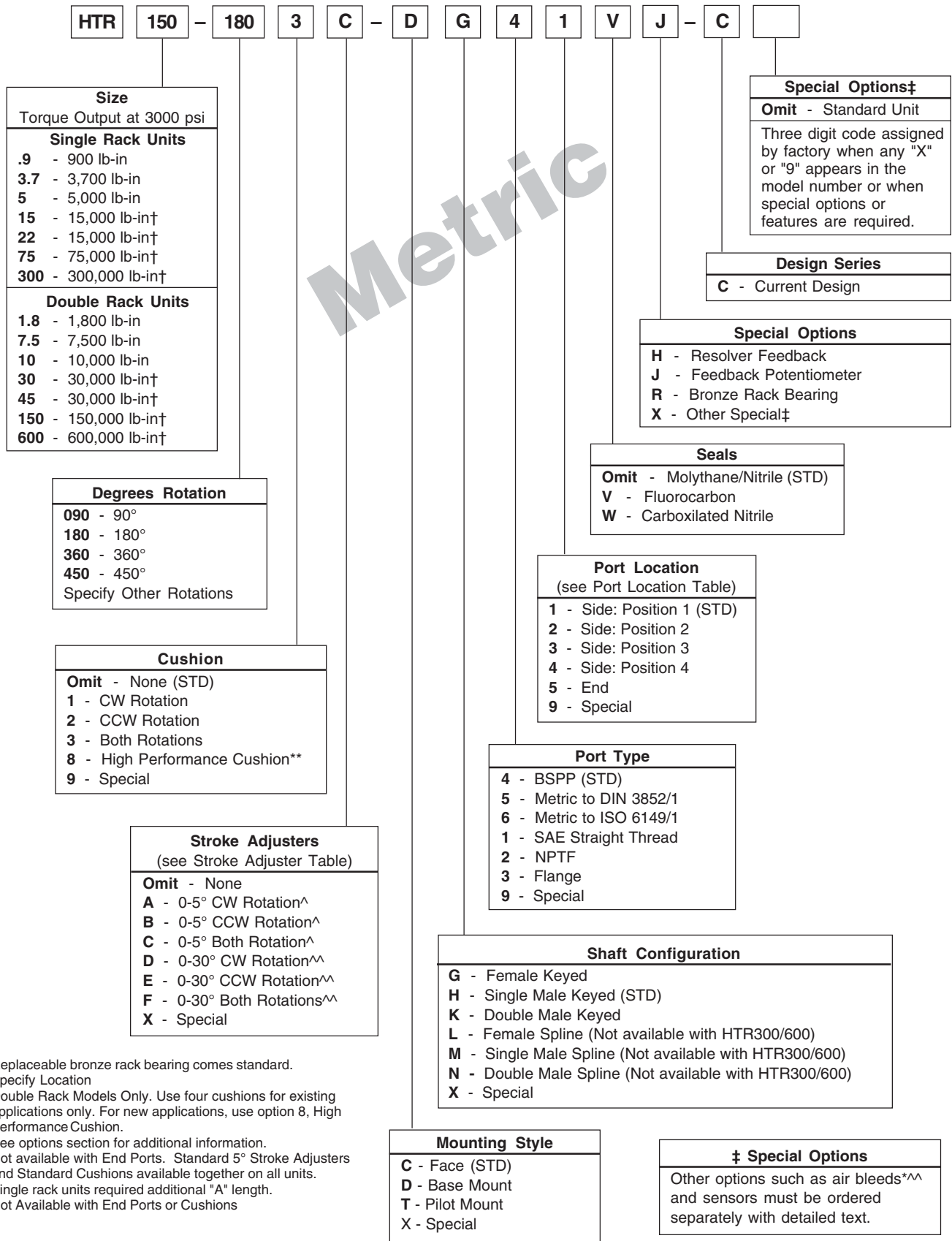

† Replaceable bronze rack bearing comes standard.  
 \* Specify Location  
 \*\* Double Rack Models Only. Use four cushions for existing applications only. For new applications, use option 8, High Performance Cushion.  
 See options section for additional information.  
 ^ Not available with End Ports. Standard 5° Stroke Adjusters and Standard Cushions available together on all units. Single rack units required additional "A" length.  
 ^^ Not Available with End Ports or Cushions



## HTR Series

The HTR Series actuator incorporates many hydraulic and mechanical features that make this actuator suitable for high production applications. These features include: high load capability tapered roller bearings; a chrome alloy steel rack and pinion gear set; a high strength ductile iron or steel housing; and proven Parker Hannifin cylinder components. These features make the HTR Series actuators robust and suitable for integration into the most demanding production systems.

The HTR Series actuators have been successfully employed in automotive plant production machinery; machine tool equipment; plastics and rubber processing machinery; basic metals production machinery and in material handling machinery.

The HTR Series actuator can be employed as an integral machine component. For example, the actuator can simultaneously transmit torque and support the line shaft or the load. Such an arrangement eliminates one set of external support bearings. For example: the optional cushions can be employed to decelerate an external load. This feature eliminates the need for an external deceleration device such as a shock absorber or a brake.

Additionally, the HTR actuator can simplify the installation of machine parts. For example: The hollow shaft feature can eliminate a coupling. The actuator shaft can be connected to the line shaft by means of a square shaft key; or the housing can be drilled and tapped to mount various brackets.

The Wear-Pak<sup>®</sup> piston uses self energizing molythane piston seals. These are the only pressurized dynamic seals. The pinion shaft uses low pressure seals. These polypak piston seals can be inspected and serviced while the actuator remains installed on the machinery.

## SPECIFICATIONS

- Maximum operating pressure: 3000 psi (207 Bar) non-shock  
except HTR22/45: 2000 psi (138 Bar) non-shock
- Standard rotations: 90°, 180°, 360°, 450°
- Rotational tolerance: -0°, +2°
- Output torques @ 3000 psi (204 Bar): 900 lb-in to 600,000 lb-in
- Maximum breakaway pressure: 70 psig (4.8 Bar)
- Mounting orientation: unrestricted
- Operating temperature range:
  - Nitrile seals -40° to 180°F (-40° to 82°C)
  - Fluorocarbon seals -20° to 250°F (-29° to 121°C)
- Standard timing: Keyway in 12:00 position at midstroke
- Recommended filtration: ISO class 17/14 or cleaner

Model		Maximum Pressure Rating, psi (Bar)	Actual Output Torque, lb-in (Nm) at Specified Pressure			Gear Train Rating Durability <sup>(1)</sup>		Maximum Angular Backlash, Minutes <sup>(4)</sup>	Standard Rotation Degrees	Displacement in <sup>3</sup> (cm <sup>3</sup> )	Standard Unit Weight, lb (kg)
			1000 psi (69 Bar)	2000 psi (138 Bar)	3000psi (207 Bar)	lbf-inch <sup>(2)</sup>	PSID <sup>(3)</sup>				
Single Rack	Double Rack										
HTR.9		3000 (204)	300 (34)	600 (68)	900 (102)	400	1340	45	90	0.57 (9.3)	11 (5)
									180	1.13 (19)	14 (6)
									360	2.27 (37)	20 (9)
	HTR1.8	3000 (204)	600 (68)	1200 (136)	1800 (203)	850	1420	45	90	1.13 (19)	16 (7)
									180	2.27 (37)	19 (9)
									360	4.53 (74)	25 (11)
HTR3.7		3000 (204)	1250 (141)	2500 (283)	3700 (418)	1570	1300	40	90	2.43 (40)	28 (13)
									180	4.86 (80)	31 (14)
									360	9.71 (159)	37 (17)
	HTR7.5	3000 (204)	2500 (283)	5000 (565)	7500 (848)	3330	1350	40	90	4.86 (79)	35 (16)
									180	9.71 (159)	41 (19)
									360	19.4 (318)	53 (24)
HTR5		3000 (204)	1650 (186)	3300 (373)	5000 (565)	2700	1620	30	90	3.12 (51)	37 (17)
									180	6.25 (102)	39 (18)
									360	12.50 (205)	49 (22)
	HTR10	3000 (204)	3300 (373)	6600 (746)	10000 (1130)	5725	1720	30	90	6.25 (102)	45 (20)
									180	12.50 (205)	54 (25)
									360	25.0 (410)	66 (30)
HTR15		3000 (204)	5000 (565)	10000 (1130)	15000 (1695)	9300	1860	25	90	8.9 (145)	55 (25)
									180	17.8 (291)	60 (27)
									360	36.5 (582)	70 (32)
	HTR30	3000 (204)	10000 (1130)	20000 (2260)	30000 (3390)	19700	1970	25	90	17.8 (291)	89 (40)
									180	35.5 (582)	97 (44)
									360	71.0 (1164)	117 (53)
HTR22		2000 (136)	7500 (848)	15000 (1695)	—	9300	1240	25	90	13.9 (227)	60 (27)
									180	27.8 (455)	66 (30)
									360	55.5 (910)	79 (36)
	HTR45	2000 (136)	15000 (1695)	30000 (3390)	—	19700	1320	25	90	27.8 (455)	98 (45)
									180	55.5 (910)	108 (49)
									360	111 (1819)	134 (61)
HTR75		3000 (204)	25000 (2825)	50000 (5650)	75000 (8475)	25000	1000	25	90	46 (754)	197 (90)
									180	92 (1508)	219 (100)
									360	184 (3016)	263 (120)
	HTR150	3000 (204)	50000 (5650)	100000 (11300)	150000 (16950)	53000	1060	25	90	92 (1508)	321 (146)
									180	184 (3016)	367 (167)
									360	368 (6032)	454 (206)
HTR300		3000 (204)	100000 (11300)	200000 (22600)	300000 (33900)	125000	1250	20	90	178 (2913)	760 (345)
									180	355 (5827)	840 (382)
									360	711 (11653)	910 (414)
	HTR600	3000 (204)	200000 (22600)	400000 (45200)	600000 (67800)	265000	1325	20	90	355 (5827)	1110 (505)
									180	711 (11653)	1260 (573)
									360	1241 (23290)	1560 (709)

1. The durability is defined as the capacity of the gear set to support the stated load without fatigue related gear surface damage. Use the durability ratings for high production duty of 1 million cycles and/or high speed applications (180° in less than three seconds or more than one cycle per minute).
2. Durability rated output torque.
3. Pressure differential between the inlet and outlet ports (non shock).
4. To minimize backlash in the actuator, order a double rack a few degrees longer and add stroke adjusters.

## Kinetic Energy Capacity

The energy values below assume drive pressure is maintained through cushion stroke.

### Single Rack Units with Single Set of Cushions (20°)

Model	Kinetic Energy Rating(in-lb) of Cushion at Specified Drive Pressure*											
	0 psi		500 psi		1000 psi		1500 psi		2000 psi		2500 psi	
	Max.	Durability	Max.	Durability	Max.	Durability	Max.	Durability	Max.	Durability	Max.	Durability
HTR.9	314	140	262	140	209	140	157	140	105	105	52	52
HTR3.7	1309	548	1091	548	872	548	654	548	436	436	218	218
HTR5	1745	942	1454	942	1163	942	873	873	582	582	291	291
HTR15	5235	3246	4362	3246	3490	3246	2618	2618	1745	1745	872	872
HTR22	5235	3246	3926	3246	2618	2618	1309	1309	0	0	0	0
HTR75	26175	8725	21812	8725	17448	8725	13088	8725	8724	8724	4362	4362
HTR300	104700	43625	87247	43625	69793	43625	52350	43625	34897	34897	17449	17449

### Double Rack Units with Single Set of Cushions (20°)

Model	Kinetic Energy Rating(in-lb) of Cushion at Specified Drive Pressure*											
	0 psi		500 psi		1000 psi		1500 psi		2000 psi		2500 psi	
	Max.	Durability	Max.	Durability	Max.	Durability	Max.	Durability	Max.	Durability	Max.	Durability
HTR1.8	314	140	209	140	105	105	0	0	0	0	0	0
HTR7.5	1309	548	873	548	436	436	0	0	0	0	0	0
HTR10	1745	942	1163	942	582	582	0	0	0	0	0	0
HTR30	5235	3246	3490	3246	1745	1745	0	0	0	0	0	0
HTR45	5235	3246	2618	2618	0	0	0	0	0	0	0	0
HTR150	26175	8725	17450	8725	8727	8725	0	0	0	0	0	0
HTR600	104700	43625	69801	43625	34907	34907	0	0	0	0	0	0

### Double Rack Units with Double Set of Cushions (20°) \*\*

Model	Kinetic Energy Rating(in-lb) of Cushion at Specified Drive Pressure*											
	0 psi		500 psi		1000 psi		1500 psi		2000 psi		2500 psi	
	Max.	Durability	Max.	Durability	Max.	Durability	Max.	Durability	Max.	Durability	Max.	Durability
HTR1.8	628	297	523	297	419	297	314	297	209	209	105	105
HTR7.5	2618	1162	2181	1162	1745	1162	1309	1162	872	872	436	436
HTR10	3490	1998	2908	1998	2326	1998	1745	1745	1163	1163	582	582
HTR30	10470	6875	8725	6875	6979	6875	5235	5235	3490	3490	1745	1745
HTR45	10470	6875	7853	6875	5235	5235	2618	2618	0	0	0	0
HTR150	52350	18497	43623	18497	34897	18497	26175	18497	17448	17448	8725	8725
HTR600	209400	92485	174493	92485	139586	92485	104700	92485	69793	69793	34899	34899

\* Must deduct work (energy) done to overcome potential energy effects of load.  $W_{PE} = T_{PE} \times \theta$ , where  $\theta$  is in radians.

\*\* Extreme care must be exercised so that both cushions are adjusted equally for each direction or dangerous pressure intensification and gear train stresses could result. (Suggest high performance cushion option.)

## Cushion Deceleration and Control

The cushion causes the resisting torque that can be used to decelerate a rotational load. Please note the cushion has to provide enough resistance to control: drive torque caused by the hydraulic system pressure; plus the torque caused by gravity pulling on the rotational load; and the kinetic energy associated with the motion of the inertia load. Since the actuator's cushion has to be able to control the sum of all three torque factors, we suggest including cushion capacity as one of the actuator's selection criteria.

It is strongly suggested that proportional valves be used instead of cushions to control (decelerate) high inertial loads. This provides the ability to reduce inlet pressure while generating deceleration pressure. It also allows for longer ramp times, thus increasing deceleration stroke.

HTR.pmd, M&A

### SUPPLEMENTAL INFORMATION KINETIC ENERGY BASIC FORMULA

$$KE = 1/2 J_m \omega^2$$

$$\omega = 0.0175 \times \frac{2\Theta_A + \Theta_C + 2\Theta_D}{\text{Rotation Time (sec.)}}$$

where:

KE = Kinetic Energy (in-lb)

$J_m$  = Rotational Mass Moment of Inertia (in-lb-sec<sup>2</sup>)

See page 8 of LTR Section for formulas.

$\omega$  = Peak Velocity (rad/sec)

(Assuming trapezoidal velocity profile)

$\Theta_A$  = Acceleration Angle (deg)

$\Theta_C$  = Constant Velocity Angle (deg)

$\Theta_D$  = Deceleration Angle (deg)

**Bearing Load Capacities**

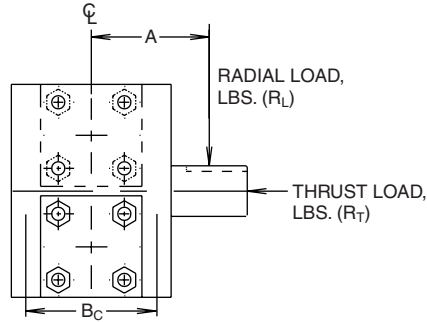

Dynamic <sup>1</sup> Bearing Load Capacities vs. Operating Pressure										
Model	Radial Load (lbs.) R <sub>L</sub> (Per Bearing) @			Thrust Load (lbs.) R <sub>T</sub> @			Bearing Centers (B <sub>c</sub> )	Overhung Moment (lb-in) R <sub>L</sub> × (A+B <sub>c</sub> /2) @		
	1,000 psid (69 bar)	2,000 psid (138 bar)	3,000 psid (207 bar)	1,000 psid (69 bar)	2,000 psid (138 bar)	3,000 psid (207 bar)		1,000 psid (69 bar)	2,000 psid (138 bar)	3,000 psid (207 bar)
HTR.9	3927	3824	3722	2690	2590	2490	0.62	2435	2371	2307
HTR1.8	4030	4030	4030	2790	2790	2790	0.62	2499	2499	2499
HTR3.7	6448	6146	5843	3610	3360	3120	1.06	6835	6514	6194
HTR7.5	6750	6750	6750	3830	3830	3830	1.06	7155	7155	7155
HTR5	8258	7956	7653	4240	4020	3810	1.02	8423	8115	7807
HTR10	8560	8560	8560	4460	4460	4460	1.02	8731	8731	8731
HTR15	14823	14286	13748	12300	11810	11330	1.83	27126	26143	25160
HTR30	15360	15360	15360	12780	12780	12780	1.83	28109	28109	28109
HTR22	14521	13681	na	12060	11330	na	1.83	26573	25037	na
HTR45	15360	15360	na	12780	12780	na	1.83	28109	28109	na
HTR75	20471	18322	16174	16540	14060	11570	3.99	81680	73106	64533
HTR150	22620	22620	22620	19020	19020	19020	3.99	90254	90254	90254
HTR300	38355	33520	28686	24090	19710	15340	5.95	228214	199447	170680
HTR600	43190	43190	43190	28460	28460	28460	5.95	256981	256981	256981

**NOTE:**

1. Static Bearing Load Capacities = Dynamic Values x 1.5
2. Values listed are "Bearing" moment capacities. Standard male shaft sizes do not provide 4:1 design factor at these operating conditions. Larger shaft sizes are available. Consult factory for further details.

**Lubrication**

In general, low speed, high torque applications require class 5 or class 6 lubrication provisions. Our assemblers use TEXACO MOLYTEX EP(2) extreme pressure grease to lubricate our gear sets as our standard lubricant. The grease should be replaced with each major overhaul.

Some high cycle applications with an operational system pressure below 1000 PSIG (69 Bar) and with adequate mechanical shock control may successfully use the hydraulic fluid as the gear train lubricant. We can modify the housing by adding a case drain line to carry away excessive lubricant. Ensure the case drain connection is looped to ensure the housing remains filled with lubricant.

High performance applications that feature high pressure and high cycle rates should consider using an external lubrication circuit system to charge the gear set with clean, cool lubricant suitable for class 3 or 4 service. An SAE80 or SAE90 lubricant circulating system should be suitable. We can modify the housing for a lubrication circuit inlet and outlet. Ensure the plumbing is run in such a way the housing remains filled with lubricant.



**HTR.9 thru HTR10 Single and Double Rack**  
**Inch Units with Face Mount (A) and Male Keyed Shaft (B)**  
**Metric Units with Face Mount (C) and Male Keyed Shaft (H)**

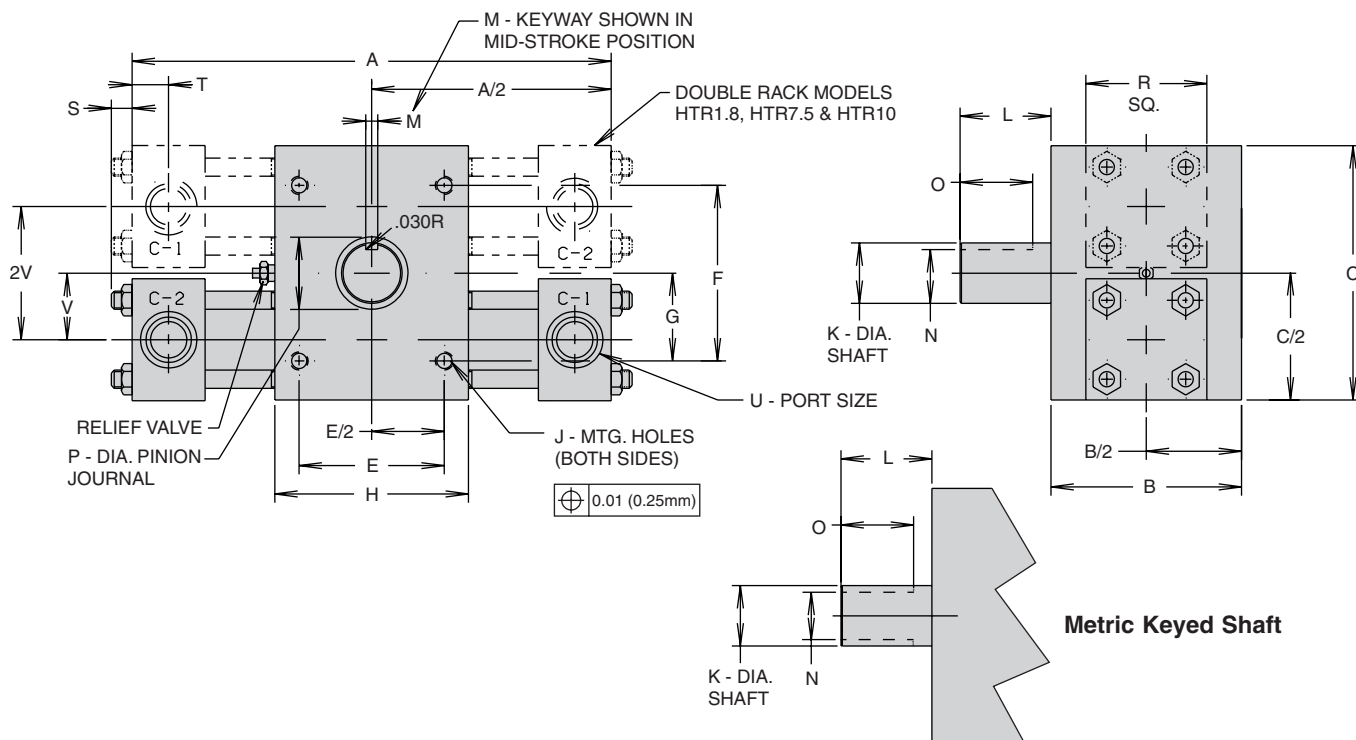

**Dimensions for Inch Units (inches)**

Model	Rotation Degrees	A	B	C	D	E	F	G	J	K	L	M	N	O	P	R	S	T	U (SAE)	V
HTR.9 HTR1.8	90	7 <sup>1</sup> / <sub>4</sub>	3	3 <sup>5</sup> / <sub>8</sub>	3 <sup>1</sup> / <sub>2</sub>	2.625	2.375	1.188	<sup>5</sup> / <sub>16</sub> -18	.875	1 <sup>5</sup> / <sub>16</sub>	.250	.732	1	1	1 <sup>3</sup> / <sub>4</sub>	3 <sup>3</sup> / <sub>8</sub>	.50	<sup>9</sup> / <sub>16</sub> -18	0.94
	180	9 <sup>1</sup> / <sub>8</sub>							x	.874		.722	<sup>9</sup> / <sub>16</sub> DP							
	360	12 <sup>7</sup> / <sub>8</sub>							1 <sup>1</sup> / <sub>2</sub> DP											
HTR3.7 HTR7.5	90	10 <sup>1</sup> / <sub>8</sub>	3 <sup>15</sup> / <sub>16</sub>	5 <sup>1</sup> / <sub>4</sub>	4	3.000	3.625	1.813	<sup>3</sup> / <sub>8</sub> -16	1.250	1 <sup>7</sup> / <sub>8</sub>	.311	1.074	1 <sup>1</sup> / <sub>2</sub>	1 <sup>1</sup> / <sub>2</sub>	2 <sup>1</sup> / <sub>2</sub>	1 <sup>1</sup> / <sub>2</sub>	.72	<sup>9</sup> / <sub>16</sub> -18	1.38
	180	13 <sup>1</sup> / <sub>8</sub>							x	1.249		1.064	<sup>9</sup> / <sub>16</sub> DP							
	360	18 <sup>1</sup> / <sub>4</sub>							1 <sup>1</sup> / <sub>2</sub> DP											
HTR5 HTR10	90	11 <sup>3</sup> / <sub>8</sub>	3 <sup>15</sup> / <sub>16</sub>	6	4	3.000	5.000	2.500	<sup>3</sup> / <sub>8</sub> -16	1.750	2 <sup>5</sup> / <sub>8</sub>	.438	1.500	2	1 <sup>25</sup> / <sub>32</sub>	2 <sup>1</sup> / <sub>2</sub>	1 <sup>1</sup> / <sub>2</sub>	.72	<sup>9</sup> / <sub>16</sub> -18	1.63
	180	14 <sup>5</sup> / <sub>8</sub>							x	1.749		1.490	<sup>9</sup> / <sub>16</sub> DP							
	360	22 <sup>1</sup> / <sub>8</sub>							1 <sup>1</sup> / <sub>2</sub> DP											

**Dimensions for Metric Units (mm)**

Model	Rotation Degrees	A	B	C	D	E	F	G	J	K +0, -.02	L	M P9	N +0, -.02	O	P	R	S	T	U BSPP/G	V
HTR.9 HTR1.8	90	184.2	76.2	92.1	88.9	70	60	30	M8	22	33	6	18.5	25.4	25.4	44.5	9.5	12.7	1/4	23.8
	180	231.8							x1.25											
	360	327.0							x13 DP											
HTR3.7 HTR7.5	90	257.2	100.0	133.4	101.6	75	90	45	M10	28	48	8	24	38.1	38.1	63.5	12.7	18.3	1/4	34.9
	180	333.4							x1.5											
	360	463.6							x16 DP											
HTR5 HTR10	90	288.9	100.0	152.4	101.6	75	125	62.5	M10	44	66	12	39	50.8	44.5	63.5	12.7	18.3	1/4	41.3
	180	371.5							x1.5											
	360	562.0							x16 DP											

**HTR15 thru HTR600 Single and Double Rack**  
**Inch Units with Face Mount (A) and Male Keyed Shaft (B)**  
**Metric Units with Face Mount (C) and Male Keyed Shaft (H)**

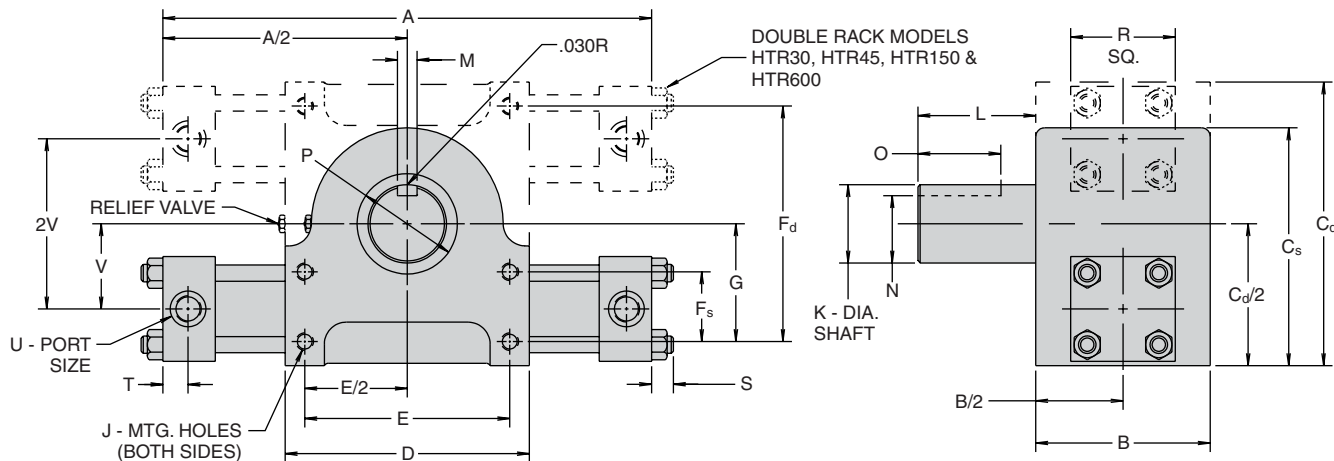

**Dimensions**

Model	Rotation Degrees	A (inch)
HTR15/30	90	16
	180	21 <sup>3</sup> / <sub>8</sub>
	360	32 <sup>1</sup> / <sub>8</sub>
HTR22/45	90	16 <sup>3</sup> / <sub>8</sub>
	180	21 <sup>3</sup> / <sub>8</sub>
	360	32 <sup>3</sup> / <sub>8</sub>
HTR75/150	90	20 <sup>1</sup> / <sub>4</sub>
	180	27 <sup>5</sup> / <sub>8</sub>
	360	42 <sup>1</sup> / <sub>4</sub>
HTR300/600	90	31 <sup>1</sup> / <sub>4</sub>
	180	43 <sup>3</sup> / <sub>4</sub>
	360	68 <sup>7</sup> / <sub>8</sub>

Model	Rotation Degrees	A (mm)
HTR15/30	90	406.4
	180	543.0
	360	816.0
HTR22/45	90	416.0
	180	552.5
	360	822.3
HTR75/150	90	514.4
	180	701.7
	360	1073.2
HTR300/600	90	793.8
	180	1111.3
	360	1749.4

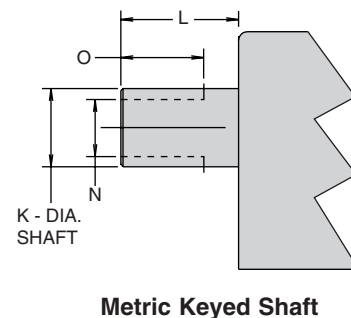

**Dimensions – Inch**

Model	B	Cd	Cs	D	E	Fd	Fs	G	J	K	L	M	N	O	P	R	S	T	U (SAE)	V
HTR15	5	—	6 <sup>7</sup> / <sub>8</sub>	7	5.875	—	2.000	3.375	1/2-13 x 3/4 DP	2.250	3 <sup>3</sup> / <sub>8</sub>	.563	1.933	2 <sup>3</sup> / <sub>8</sub>	2 <sup>7</sup> / <sub>8</sub>	3	5/8	.72	3/4-16 (#8)	2 <sup>7</sup> / <sub>16</sub>
HTR30		8 <sup>1</sup> / <sub>8</sub>	—			6.750	—													
HTR22	5	—	6 <sup>15</sup> / <sub>16</sub>	7	5.875	—	2.000	3.375	1/2-13 x 3/4 DP	2.250	3 <sup>3</sup> / <sub>8</sub>	.563	1.933	2 <sup>3</sup> / <sub>8</sub>	2 <sup>7</sup> / <sub>8</sub>	3 <sup>1</sup> / <sub>2</sub>	5/8	.72	3/4-16 (#8)	2 <sup>7</sup> / <sub>16</sub>
HTR45		8 <sup>3</sup> / <sub>8</sub>	—			6.750	—													
HTR75	7 <sup>1</sup> / <sub>2</sub>	—	10	8 <sup>1</sup> / <sub>2</sub>	6.500	—	4.500	5.750	3/4-16 x 1 <sup>1</sup> / <sub>8</sub> DP	3.000	4 <sup>1</sup> / <sub>2</sub>	.750	2.577	3 <sup>3</sup> / <sub>8</sub>	3 <sup>3</sup> / <sub>4</sub>	5	1	.84	1 <sup>1</sup> / <sub>16</sub> -12 (#12)	3 <sup>1</sup> / <sub>2</sub>
HTR150		13	—			11.500	—													
HTR300	12	—	15 <sup>1</sup> / <sub>4</sub>	15 <sup>7</sup> / <sub>8</sub>	13.000	—	5.000	7.625	1 <sup>1</sup> / <sub>4</sub> -7 x 1 <sup>7</sup> / <sub>8</sub> DP	5.000	7 <sup>1</sup> / <sub>2</sub>	1.250	4.296	6	6 <sup>1</sup> / <sub>2</sub>	7 <sup>1</sup> / <sub>2</sub>	1 <sup>1</sup> / <sub>4</sub>	1.25	1 <sup>5</sup> / <sub>16</sub> -12 (#16)	5 <sup>1</sup> / <sub>8</sub>
HTR600		18 <sup>3</sup> / <sub>4</sub>	—			13.500	—													

**Dimensions – Metric (Metric male and female shafts have 2 keyways)**

Model	B	Cd	Cs	D	E	Fd	Fs	G	J	K +0, -.02	L	M P9	N +0, -.02	O	P	R	S	T	U BSPP/G	V
HTR15	127.0	—	174.6	177.8	150	—	50	85	M12x1.75 x19 DP	54	86	14	49	60	73.0	76.2	15.9	18.3	1/2	61.9
HTR30		206.4	—			170	—													
HTR22	127.0	—	176.2	177.8	150	—	50	85	M12x1.75 x19 DP	54	86	14	49	60	73.0	88.9	15.9	18.3	1/2	61.9
HTR45		212.7	—			170	—													
HTR75	190.5	—	254.0	215.9	165	—	115	145	M20x2.5 x30 DP	76	115	22	67	85	95.3	127.0	25.4	21.3	3/4	88.9
HTR150		330.2	—			290	—													
HTR300	304.8	—	387.4	403.2	330	—	125	194	M30x3.5 x48 DP	125	190	32	114	152	165.1	190.5	31.8	31.8	1	130.2
HTR600		476.3	—			343	—													

### Cushions (1, 2, 3, 4)\*

The standard cushion operates over the last 20° of rotation in either or both directions. A floating bushing ensures no binding of cushion spear. All cushions are fully adjustable.

For severe operating conditions high performance cushions should be fitted on double rack units. On double rack units with only two cushions, cushions are located on upper cylinders.

\* For gear train durability, see chart below.

#### STANDARD CUSHION ADJUSTER NEEDLE LOCATIONS

Port Position	Cushion Adjuster Position
1	2
2	3
3	2
4**	3
5	2

\*\*Single rack only.

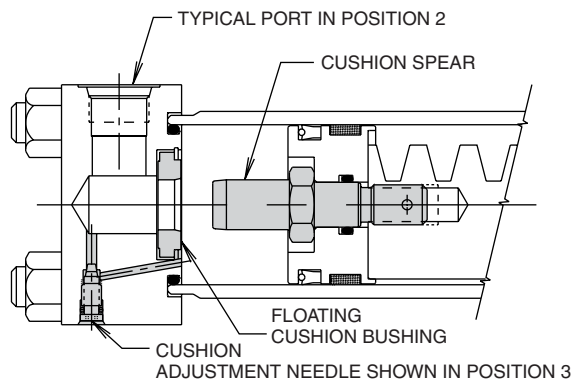

**Suggestions:** Use either Type 4 or Type 8 cushion option with HTR1.8, 7.5, 30, 45, 150 and 600 size actuators. Avoid Type 1, 2 or 3 cushions with double rack units. The use of proportional valves instead of cushions is recommended with high inertial loads.

### High Performance Cushion (8)

(This option can be specified only with double rack units)

By combining the output/exhaust flow from two cylinders, then routing it through a single cushion bushing and cushion adjuster, cushion performance is enhanced. The increased cushion flow results in better control, doubles the cushioning torque, and eliminates dangerous pressure intensification. This unique circuit also eliminates two pipe or tubing tees.

#### OPERATION:

The work ports of a standard directional valve are plumbed to ports C-1 and C-2. Port A-1 is plumbed directly to A-2, and port B-1 is plumbed to B-2. When pressure is applied to port C-1 (clockwise shaft rotation), fluid is also directed through line A to the other rack. Exhaust flow from B-1 through B-2 is directed through the cushion bushing and cushion adjustment. When the cushion spear closes off the main passage, total flow from both end caps is directed across one cushion adjustment needle, equalizing back pressure and improving performance. Alternatively, pressurizing C-2 and exhausting C-1 reverses the operation.

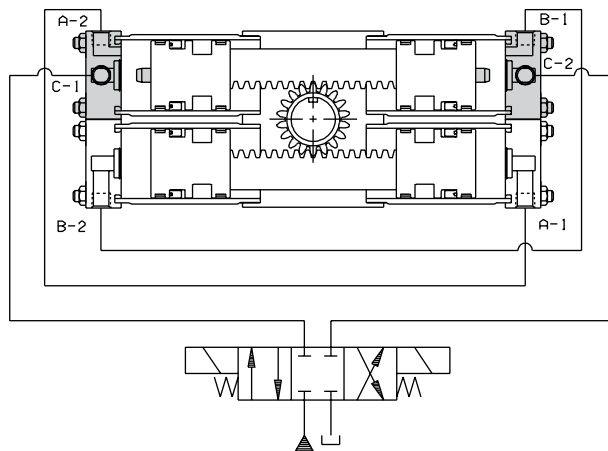

Work Ports C-1, C-2 Port Position	Cushion Adjustment Position	Connection Ports A-1, A-2, B-1, B-2 Port Position
1	2	3
2	3	1
3	2	1
5	2	3

#### DIMENSIONAL INFORMATION:

Units are identical to standard double rack and pinion units, with the exception of porting location. The chart describes the location of the ports.

#### GEAR SET DURABILITY

The table to the right provides energy ratings based on gear train durability when using various cushion options for the HTR Series.

Model	Total Energy Capacity (in-lb)		Port to Port ΔD (PSID)	
	Code 1, 2, 3	Code 8	Code 1, 2, 3	Code 8
HTR.9	140	—	1340	—
HTR1.8	140	297	670	1340
HTR3.7	548	—	1300	—
HTR7.5	548	1162	650	1300
HTR5	942	—	1620	—
HTR10	942	1998	810	1620
HTR15/22	3246	—	1860/1240	—
HTR30/45	3246	6875	930/620	1860/1240
HTR75	8725	—	1000	—
HTR150	8725	18497	500	1000
HTR300	43625	—	1250	—
HTR600	43625	92485	625	1250

**Stroke Adjusters**

Fine control of the end of travel points of the rotary actuator can be obtained by specifying stroke adjusters. These operate by reducing the maximum travel of the actuator within preset limits of either 5° or 30° in each direction. Adjustment within this range is variable and may be carried out by the user. Several types of stroke adjusters are available as shown – the designs illustrated are suitable for applications requiring infrequent adjustment.

Limit the setup of stroke adjust to 1-2 adjustments. If frequent adjustments are required, consult factory.

**Stroke Adjusters and Cushions**

5° stroke adjusters may be combined with the cushioning devices shown. 30° stroke adjusters cannot be combined with cushions. The addition of stroke adjusters requires an increase in build length. On double rack units with cushions, the cushion is fitted to the upper rack and the stroke adjuster to the lower. The increase in build length, for both single and double rack units, is shown as dimension A in the table. Cushion performance may be reduced by the addition of a stroke adjuster. Please consult the factory in critical applications.

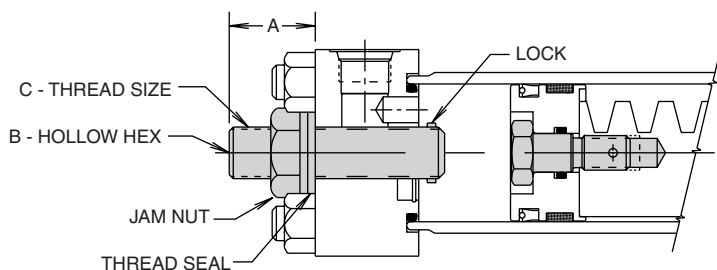

Lock limits unthreading from outside.  
Caution: damage to end cap may result if disassembled in this direction.

**TYPE I STROKE ADJUSTERS, 5° and 30°**

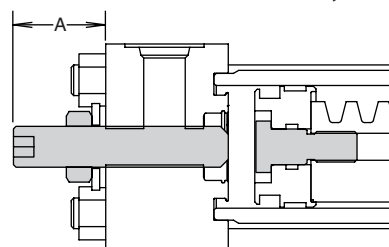

**TYPE II STROKE ADJUSTERS, 5°**

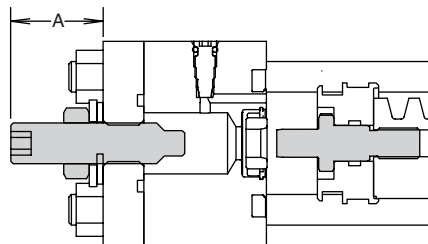

Model	One (1) Turn Adj.	A (Max)						B	C
		TYPE I 5° Adjustment w/o Cushioned End Cap		TYPE II 5° Adjustment w/ Cushioned End Cap		TYPE I 30° Adjustment w/o Cushioned End Cap			
		Inch	mm	Inch	mm	Inch	mm		
HTR.9 HTR1.8	4.2°	.50	12.7	.88	22.4	.75	19.1	5/32	5/16 - 24 UNF
HTR3.7 HTR7.5	3.3°	.63	16	1.13	28.7	1.13	28.7	1/4	1/2 - 20 UNF
HTR5 HTR10	2.5°	.63	16	1.13	28.7	1.13	28.7	1/4	1/2 - 20 UNF
HTR15/30 HTR22/45	2.0°	.88	22.4	1.81	46	1.63	41.4	3/8	3/4 - 16 UNF
HTR75 HTR150	2.0°	2.56	65	3.75	95.3	3.56	90.4	1-1/8 Ext.	1 1/2 - 12 UNF
HTR300 HTR600	CONSULT FACTORY								

**Base and Pilot Mounting**

HTR Series rotary actuators are available with the options of face, base, or pilot mounting styles to suit the requirements of different applications. Mounting dimensions for the face mounting styles are shown with other major dimensions on the previous pages. The equivalent dimensions for base and pilot mounting styles are shown in the tables below.

Model	Mounting Hole Bolt Size	Suggested Bolt Torque	Mounting Face Torque Limit*
HTR.9 HTR1.8	5/16-18 UN x 12 dp	126 lb-in	900 lb-in 1800 lb-in
HTR3.7 HTR5	3/8-16 UN x 9/16 dp	300 lb-in	3750 lb-in 7500 lb-in
HTR7.5 HTR10	3/8-16 UN x 9/16 dp	300 lb-in	7500 lb-in 10,000 lb-in
HTR15 HTR22	1/2-13 UN x 3/4 dp	60 lb-ft	15,000 lb-in 15,000 lb-in
HTR30 HTR45	1/2-13 UN x 3/4 dp	60 lb-ft	30,000 lb-in 30,000 lb-in
HTR75 HTR150	3/4-16 UN x 1-1/8 dp	160 lb-ft	63,500 lb-in 99,740 lb-in
HTR300 HTR600	1-1/4-7 UN x 1-7/8 dp	720 lb-ft	300,000 lb-in 600,000 lb-in

\*Without additional reinforcement.

**Mounting Options (B, D, P, T)**

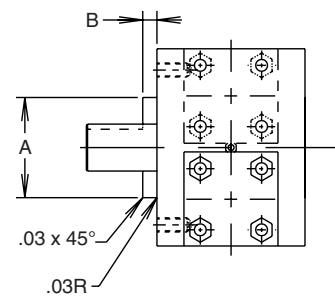
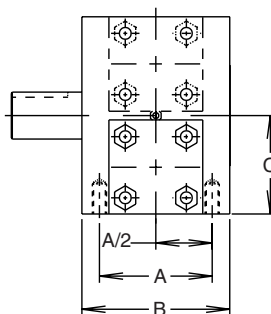
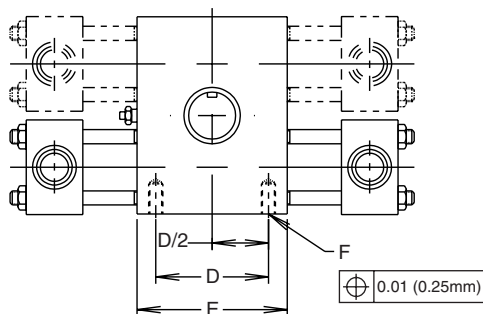

**Base Mounting – Inch (B)**

Model	A	B	C	D	E	F
HTR.9 HTR1.8	2.250	3	1.813	2.625	3 1/2	5/16-18 NC x 1/2 DP
HTR3.7 HTR7.5	3.000	3 15/16	2.625	3.000	4	3/8-16 NC x 9/16 DP
HTR5 HTR10	3.000	3 15/16	3.000	3.000	4	3/8-16 NC x 9/16 DP
HTR15/30 HTR22/45	3.875	5	4.063 4.188	5.875	7	1/2-13 NC x 3/4 DP
HTR75 HTR150	5.750	7 1/2	6.438	6.500	8 1/2	3/4-16 NF x 1 1/8 DP
HTR300 HTR600	9.500	12	9.375	13.000	15 7/8	1 1/4-7 NC x 1 7/8 DP

**Base Mounting – Metric\* (D)**

Model	A	B	C	D	E	F
HTR.9 HTR1.8	60	76.2	46.1	70	88.9	M8 x 1.25 x 13
HTR3.7 HTR7.5	75	100.0	66.7	75	101.6	M10 x 1.5 x 16
HTR5 HTR10	75	100.0	76.2	75	101.6	M10 x 1.5 x 16
HTR15/30 HTR22/45	100	127.0	103.2 106.4	150	177.8	M12 x 1.75 x 19
HTR75 HTR150	145	190.5	163.5	165	215.9	M20 x 2.5 x 30
HTR300 HTR600	240	304.8	238.2	330	403.2	M30 x 3.5 x 48

**Pilot Mounting – Inch (P), Metric (T)**

Model	Inch		Metric*	
	A	B	A	B
HTR.9 HTR1.8	1.875 1.873	1/4	47.63	6.5
HTR3.7 HTR7.5	2.625 2.623	1/4	66.68	6.5
HTR5 HTR10	2.875 2.873	1/4	73.03	6.5
HTR15/30 HTR22/45	4.250 4.248	3/8	107.95	10
HTR75 HTR150	5.500 5.498	3/8	139.67	10
HTR300 HTR600	8.750 8.748	1/2	225.25	12

\*Dimensions given in mm.

Shaft Options

Single Male Keyed (B)

Metric version (H) also available

Model	Torque, lb-in	Key Size	Suggested Key Material
HTR.9/HTR1.8	1,800	1/4 x 1/4 x 1	C1018CR
HTR3.7/HTR7.5	7,500	5/16 x 5/16 x 1 1/2	C1018CR
HTR5/HTR10	10,000	7/16 x 7/16 x 2	C1018CR
HTR15/HTR30	30,000	9/16 x 9/16 x 2 3/8	C1018CR
HTR22/HTR45	30,000	9/16 x 9/16 x 2 3/8	C1018CR
HTR75/HTR150	102,000	3/4 x 3/4 x 3 3/8	C1045CR
HTR300/HTR600	475,000	1 1/4 x 1 1/4 x 6	C1018CR

Female Keyed Shaft (A)

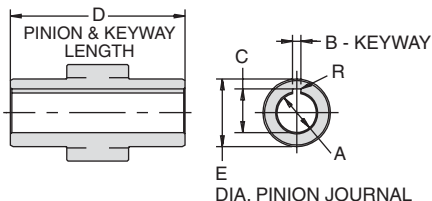

Model	Option A*						Option G (DIN 6885)**				
	A	B	C	D	E	R	A H7	B P9	C +.04	D	E
HTR.9	.625	.187	.709	2.94	1.00	.030	16	5	20.6	74.6	25.4
HTR1.8	.626	.189	.719								
HTR3.7	.875	.187	.964	3.88	1.50	.015	22	6	27.6	98.4	38.1
HTR7.5	.876	.189	.974								
HTR5	1.250	.250	1.367	3.88	1.78	.030	32	10	38.6	98.4	44.5
HTR10	1.252	.252	1.377								
HTR15	2.000	.500	2.223	4.94	2.88	.030	48	14	55.6	125.4	73.0
HTR30	2.003	.502	2.233								
HTR22	2.000	.500	2.223	4.94	2.88	.030	48	14	55.6	125.4	73.0
HTR45	2.003	.502	2.233								
HTR75	2.750	.750	3.032	7.44	3.75	.030	72	20	81.8	188.9	95.2
HTR150	2.755	.753	3.042								
HTR300	5.000	1.250	5.363	11.94	6.50	.030	125	32	139.8	303.2	165.1
HTR600	5.005	1.254	5.373								

Metric Female Keyed Shaft (G)

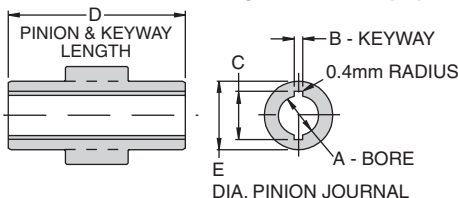

Female Splined Shaft (D, L)

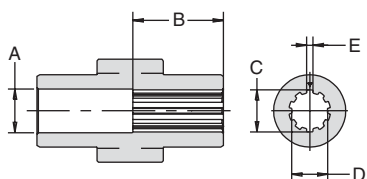

30° involute splined female shafts available for HTR300/600. Consult factory.

Model	Option D (10B Spline)*					Option L (DIN/ISO 14)**					No. of Splines
	A	B	C	D	E	A	B	C	D	E	
HTR.9	.656	.625	.625	.538	.098	17	16	16	13	3.5	6
HTR1.8			.624	.537	.096						
HTR3.7	.906	.875	.875	.753	.137	23	22	22	18	5	6
HTR7.5			.876	.752	.135						
HTR5	1.156	1.250	1.125	.968	.176	29	29	28	23	6	6
HTR10			1.124	.967	.174						
HTR15	2.031	2.000	2.000	1.720	.312	49	50	48	42	8	8
HTR30			1.998	1.718	.309						
HTR22	2.031	2.000	2.000	1.720	.312	49	50	48	42	8	8
HTR45			1.998	1.718	.309						
HTR75	3.031	3.000	3.000	2.580	.468	73	76	72	62	12	8
HTR150			2.998	2.578	.465						

Male Splined Shaft (E, M)

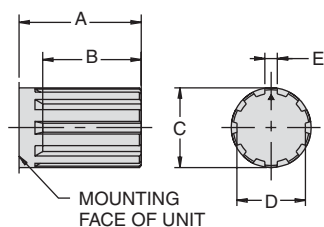

30° involute splined male shafts available for HTR300/600. Consult factory.

Model	Option E (10B Spline)*					Option M (DIN/ISO 14)**					No. of Splines
	A	B	C	D	E	A	B	C	D	E	
HTR.9	1.312	.875	.873	.747	.134	33	22	22	18	5	6
HTR1.8			.872	.742	.133						
HTR3.7	1.875	1.250	1.248	1.069	.192	48	28	28	23	6	6
HTR7.5			1.246	1.064	.191						
HTR5	2.625	1.750	1.748	1.499	.270	66	44	42	36	7	8
HTR10			1.746	1.494	.269						
HTR15	3.375	2.250	2.247	1.928	.347	86	58	54	46	9	8
HTR30			2.245	1.923	.346						
HTR22	3.375	2.250	2.247	1.928	.347	86	58	54	46	9	8
HTR45			2.245	1.923	.346						
HTR75	4.500	3.000	2.997	2.573	.464	115	76	72	62	12	8
HTR150			2.995	2.568	.463						

\* Dimensions in inches \*\* Dimensions in mm

**Options**

**Port Sizes and Positions**

The standard port styles for HTR Series rotary actuators are SAE and BSP (parallel) port, but NPTF, flanged and metric port styles to DIN 3852/1 and ISO 6149/1 are also available. The relevant sizes of port for each model of rotary actuator are shown.

Ports will be supplied in position 1, as shown in the diagram, unless a different position is specified on the order. Ports are available in positions 2, 3, and 4 at no extra cost; position 5 is available as an extra cost option.

**Air Bleeds**

These may be fitted in end cap positions unoccupied by ports or cushions. Specify location in clear text.

**Port Locations**

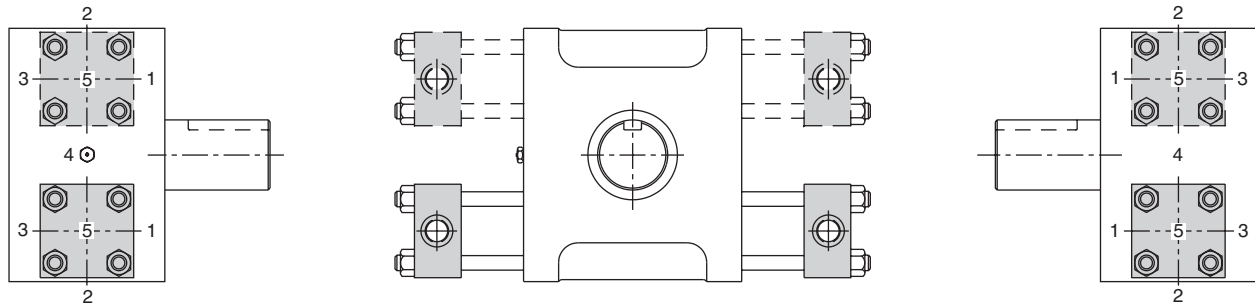

**NOTE:**

1. Port position 1 is standard.
2. Port position 2, 3 and 4 are standard options available at no additional cost.
3. Port position 5 is available at additional cost; not available with stroke adjusters.

**Port Types and Sizes**

Model	Standard SAE Straight Thread (1)	Code 61 SAE Flange (3)	NPT (2) BSPP (4)	Metric DIN (5)* or ISO (6)
HTR.9 HTR1.8	<sup>9</sup> / <sub>16</sub> - 18 (SAE 6)	N/A	1/4	M14 x 1.5
HTR3.7 HTR7.5	<sup>9</sup> / <sub>16</sub> - 18 (SAE 6)	N/A	1/4	M14 x 1.5
HTR5 HTR10	<sup>9</sup> / <sub>16</sub> - 18 (SAE 6)	N/A	1/4	M14 x 1.5
HTR15 HTR30	<sup>3</sup> / <sub>4</sub> - 16 (SAE 8)	Consult Factory	1/2	M22 x 1.5
HTR22 HTR45	<sup>3</sup> / <sub>4</sub> - 16 (SAE 8)	Consult Factory	1/2	M22 x 1.5
HTR75 HTR150	1 <sup>1</sup> / <sub>16</sub> - 12 (SAE 12)	3/4	3/4	M27 x 2
HTR300 HTR600	1 <sup>5</sup> / <sub>16</sub> - 12 (SAE 16)	1	1	M33 x 2

\* DIN 3852/1

\*\* ISO 6149/1 (Not available with HTR.9 or HTR1.8)

**Seal Materials (V,W)**

Effective filtration is vital to the long life and satisfactory performance of a rotary actuator. If the piston seals of a rack and pinion rotary are worn or damaged, fluid which leaks past the piston will enter the gear housing.

In the event of internal leakage into the gear housing, the pressure relief valve protects the shaft seal.

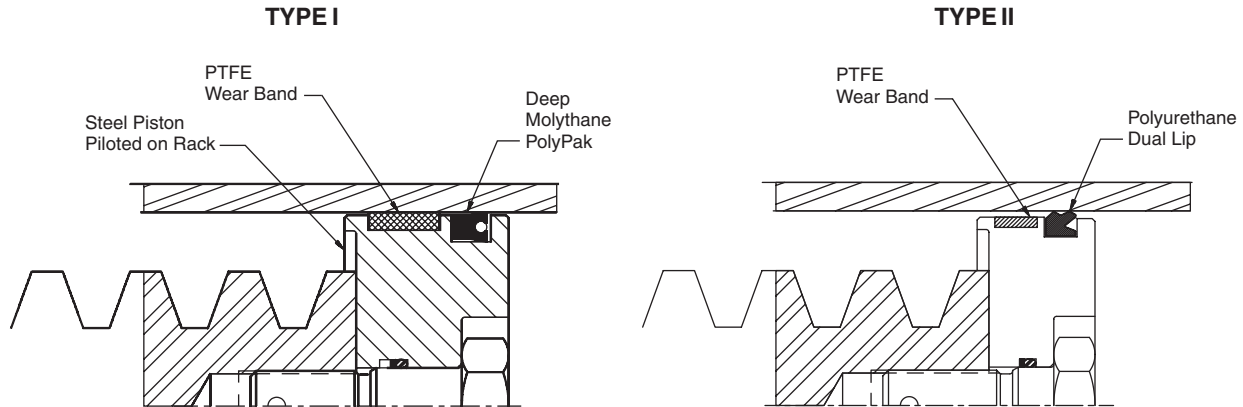

Seal Class	Seal Type	Wear Ring Type	Fluid Medium	Temperature Range	Pressure Range	Filtration
Standard Type I*	Molythane PolyPak	Filled PTFE	General purpose, Petroleum-based fluids	-40°F to 180°F -40°C to 82°C	3000 psi 207 bar	Minimum ISO Class 17/14 Cleanliness Level
Standard Type II**	Polyurethane Dual Lip	Filled PTFE	General purpose, Petroleum-based fluids	-40°F to 180°F -40°C to 82°C	3000 psi 207 bar	
Fluorocarbon (V)	Viton	Filled PTFE	High Temperature and/or Synthetic Fluids	-20°F to 250°F -29°C to 121°C	3000 psi 207 bar	
Nitrile (W)	Carboxilated Nitrile	Filled PTFE	Water Glycol, High Water Content Fluids	30°F to 180°F 0°C to 82°C	2000 psi 138 bar	

\* Standard on HTR.9/1.8, 3.7/7.5, 5/10

\*\* Standard on HTR15/30, 22/45, 75/150 and 300/600

**Seal Kit Ordering Information**

- Standard units are equipped with nitrile seals.
- Optional seal compounds are available.
- See parts list for items contained in seal kits.
- Seal kit part numbers as follows:

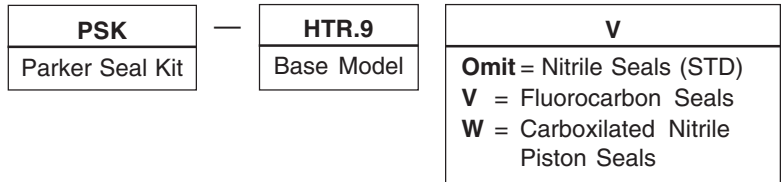

**NOTE:** The seal kit is equipped with parts necessary to re-seal Design Series "A", "B" or "C" HTR Series rotary actuators. If the actuator model number ends in C###, call factory for seal kit part number.



**Proximity Switches**  
**(Namco Cylindrical or**  
**Balluff Cylinder Indicator Sensor)**

The inductive type proximity switch provides end of rotation indication. The non-contact probe senses the presence of the ferrous cushion spear and has no springs, plungers, cams or dynamic seals that can wear out or go out of adjustment. The switch is solid state and meets NEMA 1, 12 & 13 specifications. For ease of wiring the connector housing is rotatable through 360°. To rotate, lift the cover latch, position and release.

The switch make/break activation point may occur at 0.125" to ±0.125" from the end of stroke. Depending on the actuator size, this distance may cause activation at 2° to 15° from end of stroke.

The standard proximity switch controls 50-230 VAC/DC loads from 5 to 500 mA. The low 1.7 mA off-state leakage current can allow use for direct PLC input. The standard short circuit protection (SCP) protects the switch from a short in the load or line upon sensing such a condition (5 amp or greater current) by assuming a non-conductive mode. The fault condition must be corrected and the power removed to reset the switch preventing automatic restarts.

The low voltage DC switch is also available for use with 10-30 VDC. The switch is in a non-rotatable housing, but does incorporate the short circuit protection.

Both switches are equipped with two LEDs, "Ready" and "Target". The "Ready" LED is lit when power is applied and the cushion spear is not present. The "Target" LED will light and the "Ready" LED will go out when the switch is closed, indicating the presence of the cushion spear. Both LEDs flashing indicates a short circuit condition.

**Order proximity sensors separately. See Sensors section for specifications and ordering information.**

**NOTES:**

1. Available with or without cushions.
2. Not available with stroke adjusters.
3. Pressure rating: 3000 psi
4. Operating temperature: -4°F to 158°F
5. Specify switch type, orientation and voltage when ordering.
6. The low voltage DC switch is available in non-rotatable style only, consult representative for further information.

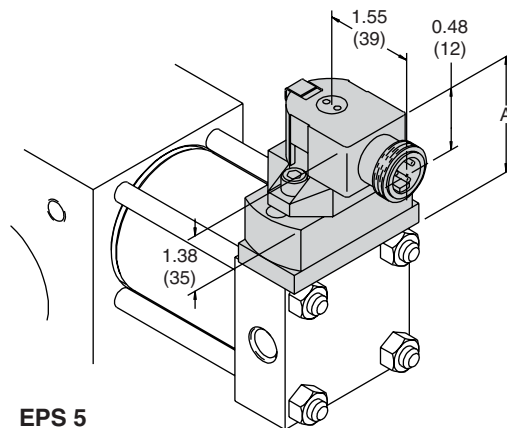

EPS 5

Model	A, inch (mm)	
	EPS 5	EPS 6&7
HTR.9 HTR1.8	1.89 (48.1)	2.21 (56.1)
HTR3.7 HTR7.5	2.38 (60.5)	2.70 (68.6)
HTR5 HTR10	2.38 (60.5)	2.70 (68.6)
HTR15 HTR30	2.32 (58.9)	2.64 (67.0)
HTR22 HTR45	2.05 (52.1)	2.37 (60.2)
HTR75 HTR150	1.55 (39.4)	1.87 (47.5)
HTR300 HTR600	3.14 (79.8)	3.45 (87.6)

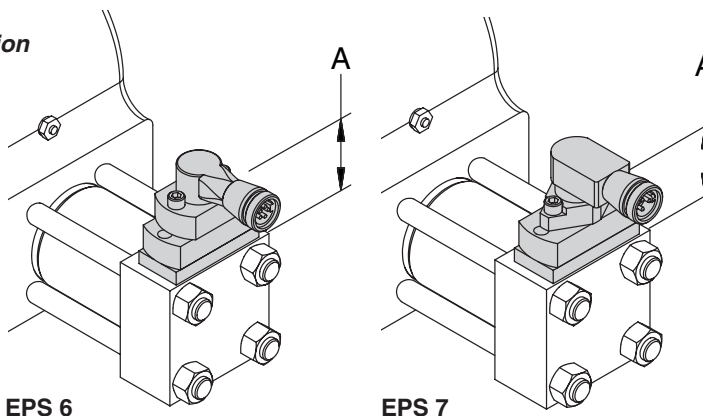

EPS 6

EPS 7

**Feedback Packages**

Feedback packages available for use with HTR Series rotary actuators include:

- Precision feedback potentiometer (J)
- Precision resolver feedback (H)
- Linear potentiometer feedback (Oildyne Teknar)
- LDT feedback (MTS Temposonics)

The feedback potentiometer (J) and resolver feedback (H) may be ordered as part of the model code. The other options must be ordered separately as specials. See Sensors section for specifications.

