



# Needle Valves

Catalog 4110-NV

December 2010

- aerospace
- climate control
- electromechanical
- filtration
- fluid & gas handling**
- hydraulics
- pneumatics
- process control**
- sealing & shielding



ENGINEERING YOUR SUCCESS.

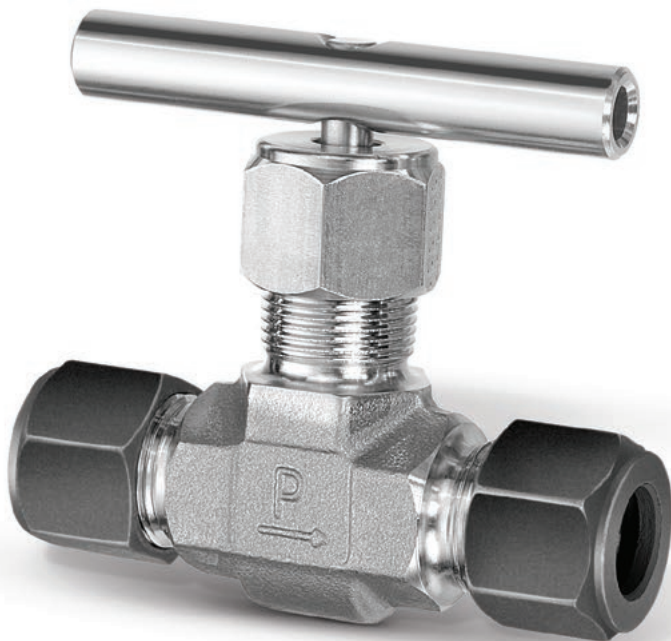

Description.....	Page
V Series Needle Valves – Integral Bonnet, 5,000 PSI Maximum* .....	2
U Series Needle Valves – Union Bonnet, 6,000 PSI Maximum* .....	12
VQ Series Toggle Valves – 600 PSI Maximum* .....	18
NP6 Series Needle Valves – Screwed Bonnet, 6,000 PSI Maximum* .....	24
SN6 Series Needle Valves – Integral Bonnet, 6,000 PSI Maximum* .....	28
PV Series Needle Valves – Rising Stem Plug Valve, 6,000 PSI Maximum* .....	32
MPN Series Needle Valves – 20,000 PSI Maximum* .....	36
Sample Cylinders and Accessories .....	44
End Connections .....	50
Offer of Sale .....	51

V

U

VQ

NP6

SN6

PV

MPN

Cyl &  
Acc

End  
Conn

\* Actual pressure rating will be determined by the valve configuration, body material, seat material and other factors.

**⚠ WARNING – USER RESPONSIBILITY**

**FAILURE OR IMPROPER SELECTION OR IMPROPER USE OF THE PRODUCTS DESCRIBED HEREIN OR RELATED ITEMS CAN CAUSE DEATH, PERSONAL INJURY AND PROPERTY DAMAGE.**

This document and other information from Parker-Hannifin Corporation, its subsidiaries and authorized distributors provide product or system options for further investigation by users having technical expertise.

The user, through its own analysis and testing, is solely responsible for making the final selection of the system and components and assuring that all performance, endurance, maintenance, safety and warning requirements of the application are met. The user must analyze all aspects of the application, follow applicable industry standards, and follow the information concerning the product in the current product catalog and in any other materials provided from Parker or its subsidiaries or authorized distributors.

To the extent that Parker or its subsidiaries or authorized distributors provide component or system options based upon data or specifications provided by the user, the user is responsible for determining that such data and specifications are suitable and sufficient for all applications and reasonably foreseeable uses of the components or systems.

**Offer of Sale**

The items described in this document are hereby offered for sale by Parker-Hannifin Corporation, its subsidiaries or its authorized distributors. This offer and its acceptance are governed by the provisions stated in the detailed "Offer of Sale" elsewhere in this document or available at [www.parker.com/ipdus](http://www.parker.com/ipdus).

© Copyright 2010 Parker Hannifin Corporation. All Rights Reserved.



## Introduction

Parker V Series Needle Valves are designed for positive leak tight shut-off and regulation of fluids in process, power, and instrumentation applications. With a wide variety of port sizes and styles, temperature capabilities ranging from -65°F to 450°F (-54°C to 232°C) and pressures to 5000 psig (345 bar), V Series Needle Valves provide the user with the utmost in flexibility when designing miniaturized tubing or piping systems.

## Features

- ▶ Choice of three stem types:
  - R-Stem – All metal, blunt stem tip
  - N-Stem – All metal, tapered needle stem tip
  - K-Stem – PCTFE stem tip
- ▶ Differential hardness between the strain hardened stem and cold formed body threads provides improved cycle life
- ▶ Choice of PTFE packing or elastomeric O-ring stem seals
- ▶ 316 Stainless Steel, Steel, Brass and Monel® Alloy 400 construction
- ▶ Inline and angle patterns
- ▶ Wide variety of US Customary and SI ports
- ▶ Panel mountable
- ▶ 100% factory tested
- ▶ Optional color coded handles

## Specifications

### Pressure Ratings:

- 316 Stainless Steel: 5000 psig (345 bar) CWP
- Brass, Steel and Monel® Alloy 400:  
3000 psig (207 bar) CWP

**Orifice:** 0.078" to 0.312" (2.0mm to 7.9mm)

**C<sub>v</sub>:** 0.12 to 1.90

**Port size:** 1/8" to 3/4" (3mm to 12mm)

### Temperature Ratings:

- Stainless Steel and Monel® Alloy 400:  
-65°F to 450°F (-54°C to 232°C)
- Brass: -65°F to 400°F (-54°C to 204°C)
- Steel: -20°F to 350°F (-29°C to 177°C)
- PTFE Packing:  
-65°F to 450°F (-54°C to 232°C)
- PCTFE Stem Tip:  
-65°F to 350°F (-54°C to 177°C)
- Nitrile Rubber Stem Seal:  
-30°F to 250°F (-34°C to 121°C)
- Fluorocarbon Rubber Stem Seal:  
-15°F to 400°F (-26°C to 204°C)
- Ethylene Propylene Rubber Stem Seal:  
-70°F to 275°F (-57°C to 135°C)

**Note:** When combining body, seat and seal materials, the most restrictive temperature rating becomes the limiting factor on temperature range.

Monel® Alloy 400 is the registered trademark of Special Metals Corporation.

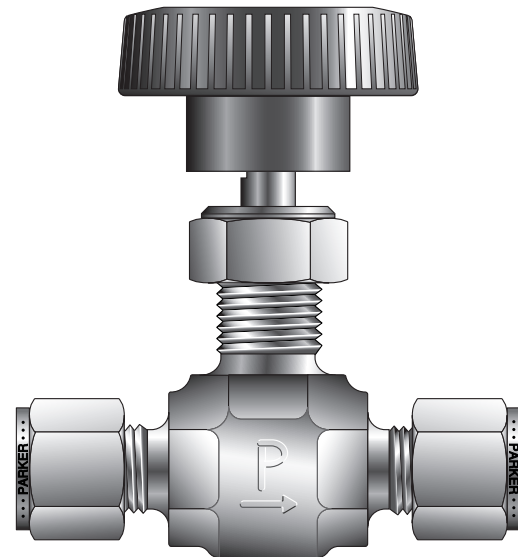

Model Shown: 4Z-V4LK-SS

## Materials of Construction (with PTFE Packing)

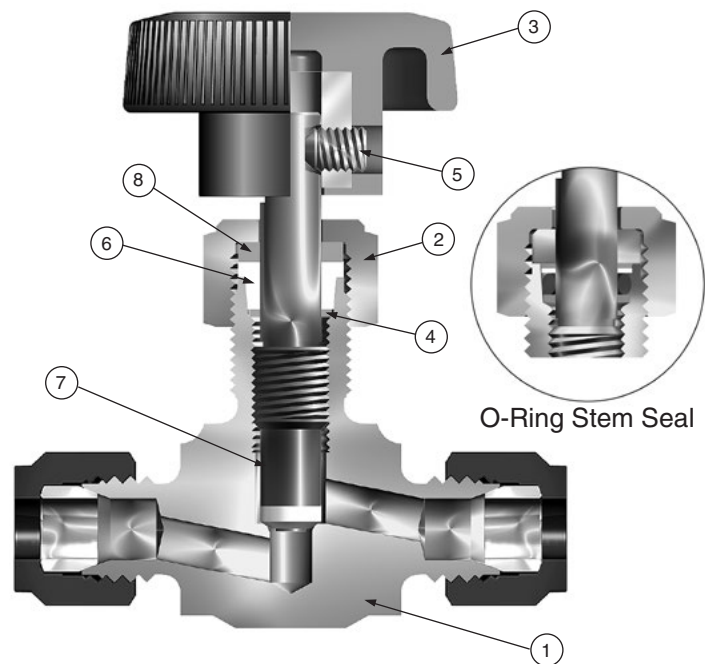

Model Shown: 4Z-V4LK-SS

## Stem Types



**K**  
PCTFE tipped

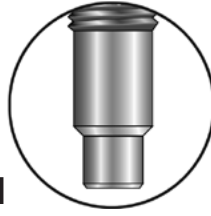

**N**  
Needle (2-1/2°)



**R**  
Blunt (30°)

## Pressure vs. Temperature

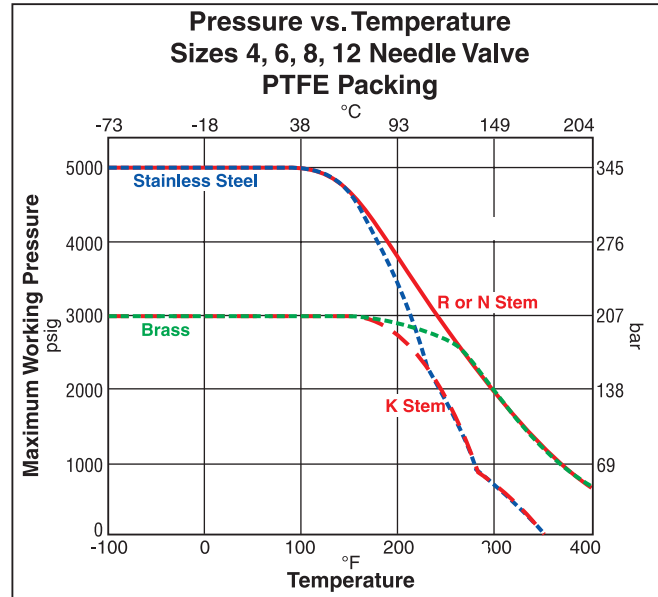
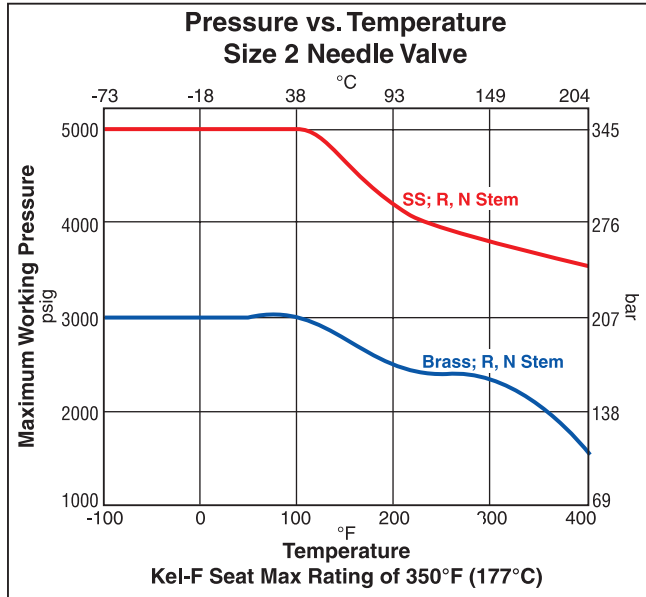

Note: To determine MPa, multiply bar by 0.1

## Materials of Construction (with PTFE Packing)

Item #	Part Description	Stainless Steel	Brass	Steel	Monel® Alloy 400
1	Body	ASTM A 182 Type F316	ASTM B 283 Alloy C37700	ASTM A 576 Grade 1214	ASTM B 564 Alloy N04400
2	Packing Nut	ASTM A 479 Type 316	ASTM A 479 Type 316	ASTM A 479 Type 316	ASTM A 479 Type 316
3	Handle*	Nylon 6/6 with SS insert	Nylon 6/6 with SS insert	Nylon 6/6 with SS insert	Nylon 6/6 with SS insert
4	Lower Packing Washer	ASTM A 479 Type 316	ASTM A 479 Type 316	ASTM A 479 Type 316	ASTM B 164 Alloy N04400
5	Handle Screw	Stainless Steel	Stainless Steel	Stainless Steel	Stainless Steel
6	Packing**	PTFE	PTFE	PTFE	PTFE
7	Stem (R and N Stem)	ASTM A 276 Type 316	ASTM A 276 Type 316	ASTM A 276 Type 316	ASTM B 164 Alloy N04400
7A	Stem (K Stem)	ASTM A 276 Type 316, with PCTFE	ASTM A 276 Type 316, with PCTFE	ASTM A 276 Type 316, with PCTFE	ASTM B 164 with PCTFE
8	Upper Packing Washer	Brass	Brass	Brass	Brass
9	Panel Nut***	316 Stainless Steel	316 Stainless Steel	316 Stainless Steel	316 Stainless Steel

\* Handles for V8 and V12 Series Valves with R and N Stems are aluminum T-bars.

\*\* Optional O-ring elastomeric stem seals are available – See How to Order.

\*\*\* Panel Nut is nickel plated brass on V2 Series Valves. Panel Nuts must be ordered separately – See page 10.  
Lubrication: Perfluorinated Polyether

## V2 Series Dimensions / Flow Data

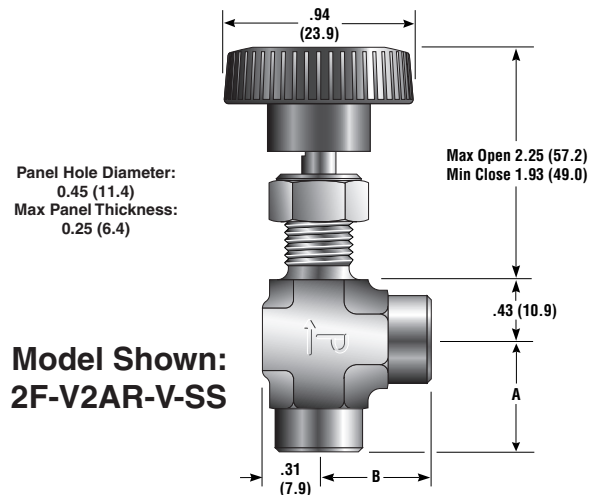
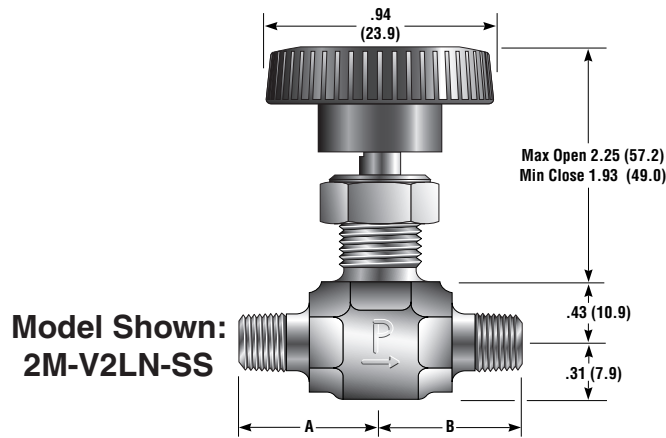

Basic Part Number		End Connections		Stem Type	Flow Data				Dimensions					
Inline	Angle	Inlet (Port 1)	Outlet (Port 2)		Orifice		Inline		Angle		A†		B†	
					Inch	mm	$C_V$	$X_T^*$	$C_V$	$X_T^*$	Inch	mm	Inch	mm
2A-V2LR	2A-V2AR	1/8" Compression A-LOK®		Blunt	0.078	2.0	0.12	0.78	0.14	0.67	1.01	25.7	1.01	25.7
2A-V2LN	2A-V2AN			Needle			0.12	0.80	0.14	0.63				
2A-V2LK	2A-V2AK			PCTFE			0.13	0.83	0.14	0.63				
2F-V2LR	2F-V2AR	1/8" Female NPT		Blunt	0.093	2.4	0.13	0.61	0.16	0.49	0.94	23.9	0.94	23.9
2F-V2LN	2F-V2AN			Needle			0.12	0.66	0.18	0.39				
2F-V2LK	2F-V2AK			PCTFE			0.12	0.73	0.17	0.54				
2M-V2LR	2M-V2AR	1/8" Male NPT		Blunt	0.093	2.4	0.13	0.61	0.16	0.49	0.75	19.1	0.75	19.1
2M-V2LN	2M-V2AN			Needle			0.12	0.66	0.18	0.39				
2M-V2LK	2M-V2AK			PCTFE			0.12	0.73	0.17	0.54				
2Z-V2LR	2Z-V2AR	1/8" Compression CPI™		Blunt	0.078	2.0	0.12	0.78	0.14	0.67	1.01	25.7	1.01	25.7
2Z-V2LN	2Z-V2AN			Needle			0.12	0.80	0.14	0.63				
2Z-V2LK	2Z-V2AK			PCTFE			0.13	0.83	0.14	0.63				
4A-V2LR	4A-V2AR	1/4" Compression A-LOK®		Blunt	0.078	2.0	0.12	0.78	0.14	0.67	1.09	27.7	1.09	27.7
4A-V2LN	4A-V2AN			Needle			0.12	0.80	0.14	0.63				
4A-V2LK	4A-V2AK			PCTFE			0.13	0.83	0.14	0.63				
4Z-V2LR	4Z-V2AR	1/4" Compression CPI™		Blunt	0.078	2.0	0.12	0.78	0.14	0.67	1.09	27.7	1.09	27.7
4Z-V2LN	4Z-V2AN			Needle			0.12	0.80	0.14	0.63				
4Z-V2LK	4Z-V2AK			PCTFE			0.13	0.83	0.14	0.63				

\* Tested in accordance with ISA S75.02. Gas flow will be choked when  $P_1 - P_2 / P_1 = X_T$ .

† For CPI™ and A-LOK®, dimensions are measured with nuts in the finger tight position.

Dimensions in inches/millimeters are for reference only, subject to change.

## V4 Series

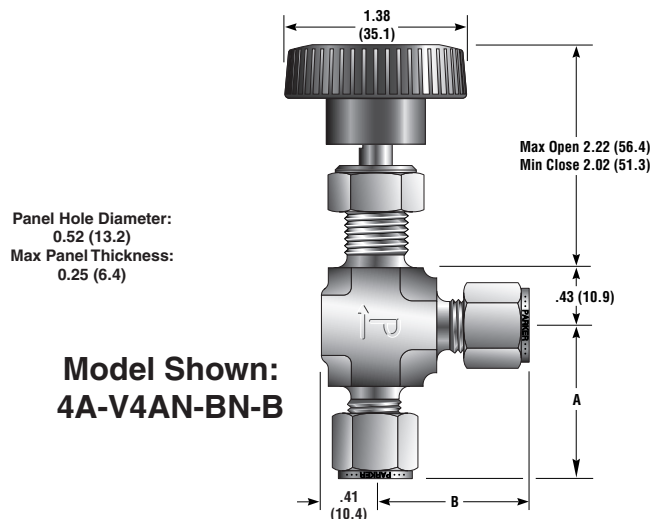
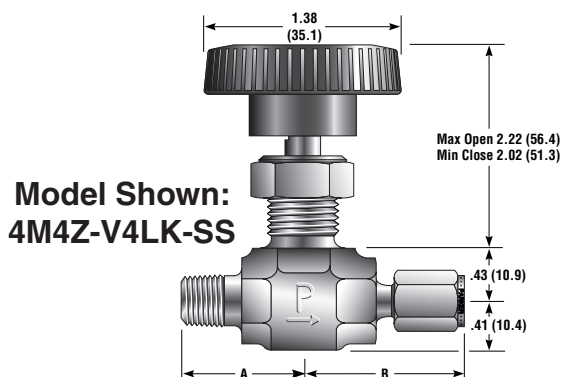

( ) Denotes dimensions in millimeters

## V4 Series Dimensions / Flow Data

Basic Part Number		End Connections		Stem Type	Flow Data				Dimensions					
		Inlet (Port 1)	Outlet (Port 2)		Orifice		Inline		Angle		A†		B†	
Inline	Angle				Inch	mm	C <sub>V</sub>	X <sub>T</sub> *	C <sub>V</sub>	X <sub>T</sub> *	Inch	mm	Inch	mm
2A-V4LR	2A-V4AR	1/8" Compression A-LOK®		Blunt	0.078	2.0	0.12	0.52	0.15	0.64	1.10	27.9	1.10	27.9
2A-V4LN	2A-V4AN			Needle			0.12	0.68	0.15	0.59				
2A-V4LK	2A-V4AK			PCTFE			0.14	0.66	0.17	0.49				
2F-V4LR	2F-V4AR	1/8" Female NPT		Blunt	0.176	4.5	0.43	0.77	0.55	0.63	0.81	20.6	0.81	20.6
2F-V4LN	2F-V4AN			Needle			0.43	0.69	0.55	0.63				
2F-V4LK	2F-V4AK			PCTFE			0.45	0.55	0.58	0.68				
2M-V4LR	2M-V4AR	1/8" Male NPT		Blunt	0.125	3.2	0.28	0.67	0.36	0.55	0.81	20.6	0.81	20.6
2M-V4LN	2M-V4AN			Needle			0.28	0.63	0.36	0.51				
2M-V4LK	2M-V4AK			PCTFE			0.29	0.51	0.37	0.59				
2Z-V4LR	2Z-V4AR	1/8" Compression CPI™		Blunt	0.078	2.0	0.12	0.52	0.15	0.64	1.10	27.9	1.10	27.9
2Z-V4LN	2Z-V4AN			Needle			0.12	0.68	0.15	0.59				
2Z-V4LK	2Z-V4AK			PCTFE			0.14	0.66	0.17	0.49				
4A-V4LR	4A-V4AR	1/4" Compression A-LOK®		Blunt	0.176	4.5	0.43	0.85	0.55	0.63	1.15	29.2	1.15	29.2
4A-V4LN	4A-V4AN			Needle			0.43	0.77	0.55	0.63				
4A-V4LK	4A-V4AK			PCTFE			0.45	0.69	0.58	0.68				
4M-V4LR	4M-V4AR	1/4" Male NPT		Blunt	0.176	4.5	0.43	0.85	0.55	0.63	0.94	23.9	0.94	23.9
4M-V4LN	4M-V4AN			Needle			0.43	0.77	0.55	0.63				
4M-V4LK	4M-V4AK			PCTFE			0.45	0.69	0.58	0.68				
4W-V4LR	4W-V4AR	1/4" Tube Socket Weld		Blunt	0.176	4.5	0.43	0.85	0.55	0.63	0.80	20.3	0.80	20.3
4W-V4LN	4W-V4AN			Needle			0.43	0.77	0.55	0.63				
4W-V4LK	4W-V4AK			PCTFE			0.45	0.69	0.58	0.68				
4Z-V4LR	4Z-V4AR	1/4" Compression CPI™		Blunt	0.176	4.5	0.43	0.85	0.55	0.63	1.15	29.2	1.15	29.2
4Z-V4LN	4Z-V4AN			Needle			0.43	0.77	0.55	0.63				
4Z-V4LK	4Z-V4AK			PCTFE			0.45	0.69	0.58	0.68				
6A-V4LR	6A-V4AR	3/8" Compression A-LOK®		Blunt	0.176	4.5	0.43	0.85	0.55	0.63	1.17	29.7	1.17	29.7
6A-V4LN	6A-V4AN			Needle			0.43	0.77	0.55	0.63				
6A-V4LK	6A-V4AK			PCTFE			0.45	0.69	0.58	0.68				
6Z-V4LR	6Z-V4AR	3/8" Compression CPI™		Blunt	0.176	4.5	0.43	0.85	0.55	0.63	1.17	29.7	1.17	29.7
6Z-V4LN	6Z-V4AN			Needle			0.43	0.77	0.55	0.63				
6Z-V4LK	6Z-V4AK			PCTFE			0.45	0.69	0.58	0.68				
M3A-V4LR	M3A-V4AR	3mm Compression A-LOK®		Blunt	0.078	2.0	0.12	0.52	0.15	0.64	1.10	27.9	1.10	27.9
M3A-V4LN	M3A-V4AN			Needle			0.12	0.68	0.15	0.59				
M3A-V4LK	M3A-V4AK			PCTFE			0.14	0.66	0.17	0.49				
M3Z-V4LR	M3Z-V4AR	3mm Compression CPI™		Blunt	0.078	2.0	0.12	0.52	0.15	0.64	1.10	27.9	1.10	27.9
M3Z-V4LN	M3Z-V4AN			Needle			0.12	0.68	0.15	0.59				
M3Z-V4LK	M3Z-V4AK			PCTFE			0.14	0.66	0.17	0.49				
M6A-V4LR	M6A-V4AR	6mm Compression A-LOK®		Blunt	0.156	4.0	0.37	0.78	0.48	0.60	1.15	29.2	1.15	29.2
M6A-V4LN	M6A-V4AN			Needle			0.37	0.72	0.48	0.58				
M6A-V4LK	M6A-V4AK			PCTFE			0.39	0.62	0.51	0.64				
M6Z-V4LR	M6Z-V4AR	6mm Compression CPI™		Blunt	0.156	4.0	0.37	0.78	0.48	0.60	1.15	29.2	1.15	29.2
M6Z-V4LN	M6Z-V4AN			Needle			0.37	0.72	0.48	0.58				
M6Z-V4LK	M6Z-V4AK			PCTFE			0.39	0.62	0.51	0.64				
M8A-V4LR	M8A-V4AR	8mm Compression A-LOK®		Blunt	0.176	4.5	0.43	0.85	0.55	0.63	1.18	30.0	1.18	30.0
M8A-V4LN	M8A-V4AN			Needle			0.43	0.77	0.55	0.63				
M8A-V4LK	M8A-V4AK			PCTFE			0.45	0.69	0.58	0.68				
M8Z-V4LR	M8Z-V4AR	8mm Compression CPI™		Blunt	0.176	4.5	0.43	0.85	0.55	0.63	1.18	30.0	1.18	30.0
M8Z-V4LN	M8Z-V4AN			Needle			0.43	0.77	0.55	0.63				
M8Z-V4LK	M8Z-V4AK			PCTFE			0.45	0.69	0.58	0.68				

\* Tested in accordance with ISA S75.02. Gas flow will be choked when  $P_1 - P_2 / P_1 = x_T$ .  
 † For CPI™ and A-LOK®, dimensions are measured with nuts in the finger tight position.

Dimensions in inches/millimeters are for reference only, subject to change.

## V6 Series Dimensions / Flow Data

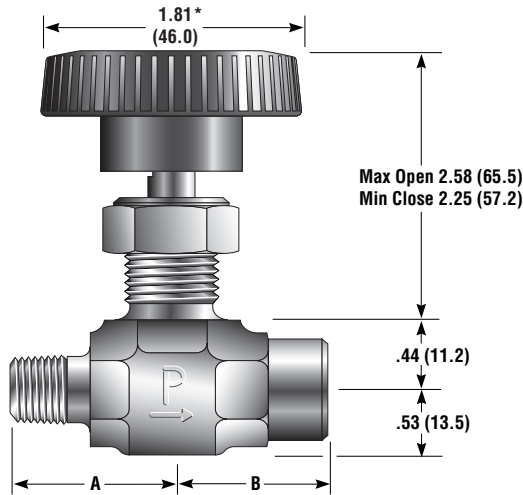

**Model Shown:  
6M4F-V6LR-V-SS**

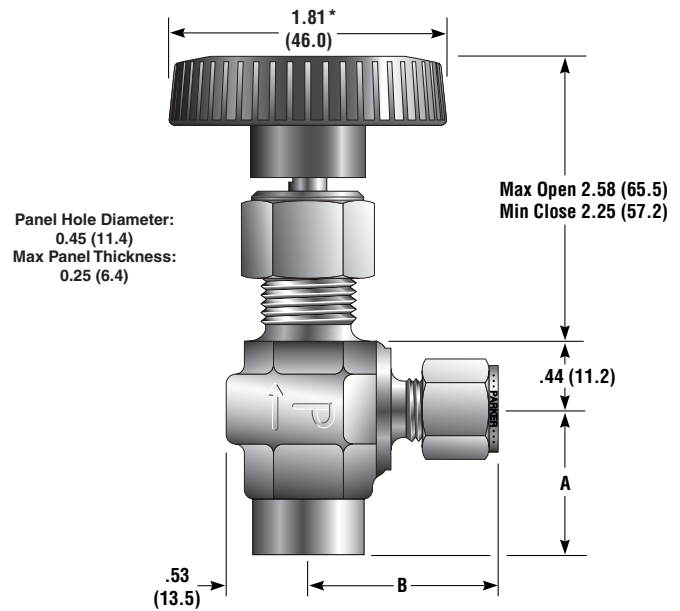

**Model Shown:  
4F6Z-V6AK-SS**

\* Note: Handle diameter for K Stem V6 Series Valves is 1.38 (35.4)  
( ) Denotes dimensions in millimeters

Basic Part Number		End Connections		Stem Type	Flow Data				Dimensions					
		Inlet (Port 1)	Outlet (Port 2)		Orifice		Inline		Angle		A†		B†	
Inline	Angle				Inch	mm	$C_V$	$X_T^*$	$C_V$	$X_T^*$	Inch	mm	Inch	mm
4F-V6LR	4F-V6AR	1/4" Female NPT		Blunt	0.228	5.8	0.73	0.90	1.23	0.50	0.94	23.9	0.94	23.9
4F-V6LN	4F-V6AN			Needle			0.55	0.61	0.92	0.62				
4F-V6LK	4F-V6AK			PCTFE			0.80	0.87	1.23	0.56				
6A-V6LR	6A-V6AR	3/8" Compression A-LOK®		Blunt	0.228	5.8	0.73	0.90	1.23	0.50	1.29	32.8	1.29	32.8
6A-V6LN	6A-V6AN			Needle			0.55	0.61	0.92	0.62				
6A-V6LK	6A-V6AK			PCTFE			0.80	0.87	1.23	0.56				
6M-V6LR	6M-V6AR	3/8" Male NPT		Blunt	0.228	5.8	0.73	0.90	1.23	0.50	1.03	26.2	1.03	26.2
6M-V6LN	6M-V6AN			Needle			0.55	0.61	0.92	0.62				
6M-V6LK	6M-V6AK			PCTFE			0.80	0.87	1.23	0.56				
6Z-V6LR	6Z-V6AR	3/8" Compression CPI™		Blunt	0.228	5.8	0.73	0.90	1.23	0.50	1.29	32.8	1.29	32.8
6Z-V6LN	6Z-V6AN			Needle			0.55	0.61	0.92	0.62				
6Z-V6LK	6Z-V6AK			PCTFE			0.80	0.87	1.23	0.56				
8A-V6LR	8A-V6AR	1/2" Compression A-LOK®		Blunt	0.228	5.8	0.73	0.90	1.23	0.50	1.40	35.6	1.40	35.6
8A-V6LN	8A-V6AN			Needle			0.55	0.61	0.92	0.62				
8A-V6LK	8A-V6AK			PCTFE			0.80	0.87	1.23	0.56				
8Z-V6LR	8Z-V6AR	1/2" Compression CPI™		Blunt	0.228	5.8	0.73	0.90	1.23	0.50	1.40	35.6	1.40	35.6
8Z-V6LN	8Z-V6AN			Needle			0.55	0.61	0.92	0.62				
8Z-V6LK	8Z-V6AK			PCTFE			0.80	0.87	1.23	0.56				
M10A-V6LR	M10A-V6AR	10mm Compression A-LOK®		Blunt	0.228	5.8	0.73	0.90	1.23	0.50	1.30	33.0	1.30	33.0
M10A-V6LN	M10A-V6AN			Needle			0.55	0.61	0.92	0.62				
M10A-V6LK	M10A-V6AK			PCTFE			0.80	0.87	1.23	0.56				
M10Z-V6LR	M10Z-V6AR	10mm Compression CPI™		Blunt	0.228	5.8	0.73	0.90	1.23	0.50	1.30	33.0	1.30	33.0
M10Z-V6LN	M10Z-V6AN			Needle			0.55	0.61	0.92	0.62				
M10Z-V6LK	M10Z-V6AK			PCTFE			0.80	0.87	1.23	0.56				

\* Tested in accordance with ISA S75.02. Gas flow will be choked when  $P_1 - P_2 / P_1 = X_T$ .

† For CPI™ and A-LOK®, dimensions are measured with nuts in the finger tight position.

Dimensions in inches/millimeters are for reference only, subject to change.



## V8 Series Dimensions / Flow Data

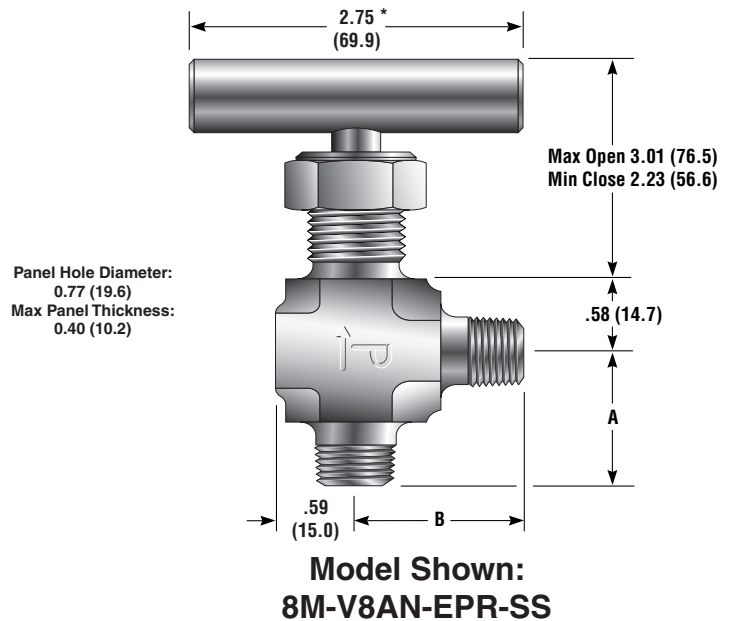
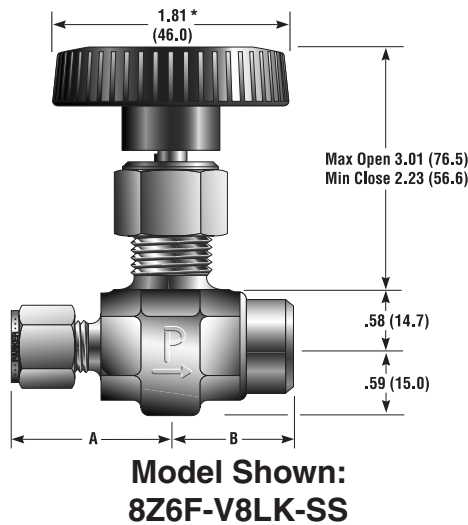

\* Note: Handles for N or R Stem V8 Series Valves are a T-bar  
( ) Denotes dimensions in millimeters

Basic Part Number		End Connections		Stem Type	Flow Data				Dimensions					
Inline	Angle	Inlet (Port 1)	Outlet (Port 2)		Orifice		Inline		Angle		A†		B†	
					Inch	mm	$C_V$	$X_T^*$	$C_V$	$X_T^*$	Inch	mm	Inch	mm
6F-V8LR	6F-V8AR	3/8" Female NPT		Blunt	0.312	7.9	1.23	0.87	1.66	0.72	1.34	34.0	1.34	34.0
6F-V8LN	6F-V8AN			Needle			1.05	0.83	1.28	0.80				
6F-V8LK	6F-V8AK			PCTFE			1.29	0.91	1.90	0.76				
8A-V8LR	8A-V8AR	1/2" Compression A-LOK®		Blunt	0.312	7.9	1.23	0.87	1.66	0.72	1.53	38.9	1.53	38.9
8A-V8LN	8A-V8AN			Needle			1.05	0.83	1.28	0.80				
8A-V8LK	8A-V8AK			PCTFE			1.29	0.91	1.90	0.76				
8M-V8LR	8M-V8AR	1/2" Male NPT		Blunt	0.312	7.9	1.23	0.87	1.66	0.72	1.34	34.0	1.34	34.0
8M-V8LN	8M-V8AN			Needle			1.05	0.83	1.28	0.80				
8M-V8LK	8M-V8AK			PCTFE			1.29	0.91	1.90	0.76				
8Z-V8LR	8Z-V8AR	1/2" Compression CPI™		Blunt	0.312	7.9	1.23	0.87	1.66	0.72	1.53	38.9	1.53	38.9
8Z-V8LN	8Z-V8AN			Needle			1.05	0.83	1.28	0.80				
8Z-V8LK	8Z-V8AK			PCTFE			1.29	0.91	1.90	0.76				
M10A-V8LR	M10A-V8AR	10mm Compression A-LOK®		Blunt	0.281	7.1	1.13	0.79	1.52	0.66	1.42	36.1	1.42	36.1
M10A-V8LN	M10A-V8AN			Needle			0.97	0.78	1.18	0.75				
M10A-V8LK	M10A-V8AK			PCTFE			1.18	0.80	1.69	0.66				
M10Z-V8LR	M10Z-V8AR	10mm Compression CPI™		Blunt	0.281	7.1	1.13	0.79	1.52	0.66	1.42	36.1	1.42	36.1
M10Z-V8LN	M10Z-V8AN			Needle			0.97	0.78	1.18	0.75				
M10Z-V8LK	M10Z-V8AK			PCTFE			1.18	0.80	1.69	0.66				
M12A-V8LR	M12A-V8AR	12mm Compression A-LOK®		Blunt	0.281	7.1	1.13	0.79	1.52	0.66	1.51	38.4	1.51	38.4
M12A-V8LN	M12A-V8AN			Needle			0.97	0.78	1.18	0.75				
M12A-V8LK	M12A-V8AK			PCTFE			1.18	0.80	1.69	0.66				
M12Z-V8LR	M12Z-V8AR	12mm Compression CPI™		Blunt	0.281	7.1	1.13	0.79	1.52	0.66	1.51	38.4	1.51	38.4
M12Z-V8LN	M12Z-V8AN			Needle			0.97	0.78	1.18	0.75				
M12Z-V8LK	M12Z-V8AK			PCTFE			1.18	0.80	1.69	0.66				

\* Tested in accordance with ISA S75.02. Gas flow will be choked when  $P_1 - P_2 / P_1 = X_T$ .  
† For CPI™ and A-LOK®, dimensions are measured with nuts in the finger tight position.

Dimensions in inches/millimeters are for reference only, subject to change.



## How to Order

Dimensions in inches/millimeters are for reference only, subject to change.

The correct part number is easily derived from the following example and ordering chart. The six product characteristics required are coded as shown in the chart.

Example 1, below, describes an angle pattern V4 Series needle valve equipped with 1/4" CPI™ compression inlet and outlet ports, a PCTFE tipped stem, Nitrile seals, and stainless steel construction.

Example 2, below, describes an inline pattern V6 Series needle valve equipped with 1/4" male NPT inlet port, 1/4" female NPT outlet port, a needle stem type, PTFE stem seal, brass construction.

**Example 1: 4Z-V4AK-BN-SS** (shown in the part number blocks below)

**Example 2: 4M4F-V6LN-B**

4Z		-		V4	AK	-		BN	-		SS
Inlet Port*		Outlet Port*		Valve Series	Stem Type	Stem Seal		Body Material			
Inlet Port*	Outlet Port*	Valve Series	Stem Type	Stem Seal	Body Material						
2A 2M 4A		V2A	R Blunt (30°)	Blank PTFE	SS Stainless Steel						
2F 2Z 4Z		V2L	N Needle (2-1/2°)	BN Nitrile Rubber	S Steel						
2A 4A 6A M6A		V4A	K PCTFE	EPR Ethylene Propylene Rubber	M Monel® Alloy 400						
2F 4M 6Z M6Z		V4L		V Fluorocarbon Rubber	B Brass						
2M 4W M3A M8A		V6A									
2Z 4Z M3Z M8Z		V6L									
4A 6A 8A M10A		V8A									
4F 6M 8Z M10Z		V8L									
4M 6W M8A M12A											
4Z 6Z M8Z M12Z											
4F 6Z 8Z M12A		V12A									
6A 8A M10A M12Z		V12L									
6F 8M M10Z											
8F 10A 12A											
8W 10Z 12Z											

\*If the inlet and outlet ports are the same, eliminate the outlet port designator.

## How to Order Options

**Colored Round Handles** – Add the designator corresponding to the correct handle color as a suffix to the part number. Black is standard, **W** - white, **B** - blue, **G** - green, **R** - red, **Y** - yellow. **Example:** M10A-V6LK-SS-**G**

**Oxygen Cleaning** – Add the suffix **-C3** to the end of the part number to receive valves cleaned and assembled for oxygen service in accordance with Parker Specification ES8003. **Example:** 4A-V4AN-EPR-SS-**C3**

## How to Order Components

**Colored Round Nylon Handles with Handle Screw** – Valve Series-Handle-Color. **Example: V4-HANDLE-BLUE**

**Stainless Steel T-Bar Handles with Handle Screw** – **Examples:** V2: V2-BAR-HANDLE-SS; V4: V4-BAR-HANDLE-SS; V6: V6-BAR-HANDLE-SS; V8: U12-BAR-HANDLE-SS; V12: U12-BAR-HANDLE-SS

**Aluminum T-Bar Handles with Handle Screw** – **Examples:** V2: Not available; V4: V4-BAR-HANDLE-AL; V6: V4-BAR-HANDLE-AL; V8: U12-BAR-HANDLE-AL; V12: U12-BAR-HANDLE-AL

**Panel Mounting Nuts** – **Examples:** V2: 2-Panel-Nut-SS; V4: 4-Panel-Nut-SS; V6: 6-Panel-Nut-SS; V8: 8-Panel-Nut-SS

## How to Order Maintenance Kits

**PTFE Packing Stem Kits** – Consists of One Stem; One PTFE Packing; One Upper Packing Washer; One Lower Packing Washer; One Packing Nut; Maintenance Instructions.

Kit-Valve Series and StemType-Body Material. **Examples: KIT-V4K-SS; KIT-V6N-B**

**Fluorocarbon Rubber Packing Stem Kits** – Consists of One Stem; One Fluorocarbon Rubber O-ring Seal; One O-ring Back-up Gland; One O-ring Gland; One Lower Packing Washer; One Packing Nut; Maintenance Instructions.

Kit-Valve Series and Stem Type-V-Body Material. **Examples: KIT-V2R-V-B; KIT-V4K-V-SS**

**Nitrile Rubber Packing Stem Kits** – Consists of One Stem; One Nitrile Rubber O-ring Seal; One O-ring Back-up Gland; One O-ring Gland; One Lower Packing Washer; One Packing Nut; Maintenance Instructions.

Kit-Valve Series and Stem Type-BN-Body Material. **Examples: KIT-V2R-BN-B; KIT-V4K-BN-SS**

**Ethylene Propylene Rubber Packing Stem Kits** – Consists of One Stem; One Ethylene Propylene Rubber O-ring Seal; One O-ring Back-up Gland; One O-ring Gland; One Lower Packing Washer; One Packing Nut; Maintenance Instructions.

Kit-Valve Series and Stem Type-EPR-Body Material. **Examples: KIT-V2R-EPR-B; KIT-V4K-EPR-SS**



## Introduction

Parker U Series Union Bonnet Valves have been engineered for use at pressures up to 6,000 (414 bar) and temperatures as high as 1,200°F (649°C). A non-rotating lower stem helps to extend packing life by removing rotation from the packing area. Stem packing below the threads isolates the thread lubricant from the flow, ensuring adequate lubrication regardless of the media.

## Features

- ▶ Union bonnet design ensures high integrity seal under severe service applications
- ▶ Packing below the power threads protects thread lubricants from media and isolates the lubricants from the media
- ▶ Dust seal in the packing nut protects stem threads from external contamination
- ▶ Stem swivel above the packing eliminates entrapment area and increases packing life
- ▶ Choice of Grafoil® or PTFE packing
- ▶ Choice of Regulating or Blunt stem types. Blunt stem type helps combat wire draw which may occur when two phase flow is present (i.e. steam service)
- ▶ 316 stainless steel construction
- ▶ Wide variety of US Customary and SI ports
- ▶ Panel mountable
- ▶ 100% factory tested

## Materials of Construction

Item #	Description	Material
*1	Body	ASTM A 182, Type F316
2	Bonnet Nut	ASTM A 479, Type 316
*3	Bonnet	ASTM A 479, Type 316
*4	Lower Stem*	ASTM A 564, Type 630
5	Upper Stem	ASTM A 564, Type 630
6	Stem Guide	ASTM A 581, Type 416
7	Ball	440-C Stainless Steel
*8	Bonnet Seal**	Nickel-Chromium-Iron Alloy
9	Packing Nut	ASTM A 479, Type 316
*10	Packing***	Grafoil®
*11	Packing Washer	316 Stainless Steel
12	Handle****	Aluminum
13	Handle Screw	316 Stainless Steel
14	Dust Seal*****	Nylon 6/6
15	Locking Nut	Stainless Steel

\* Wetted parts

\* Lower Stem material is ASTM A 276 Type 316 with HT option

\*\* Not required on U6 and U12 Series which have metal-to-metal seals

\*\*\* Optional PTFE Packing is available

\*\*\*\* Handle material is stainless steel with HT option

\*\*\*\*\* Dust Seal not available with HT option

Lubrication: Molybdenum disulfide with soft metallic fillers

## Specifications

### Pressure Rating:

6000 psig (414 bar) CWP

### Temperature Rating:

PTFE packing:

-65°F to 450°F (-54°C to 232°C)

Grafoil® packing:

-65°F to 700°F (-54°C to 371°C)

Grafoil® packing with HT option:

-65°F to 1200°F (-54°C to 649°C)

**Orifice:** .177" to .437" (4.5mm to 11.1mm)

**Cv:** .53 to 3.55

### Pressure Rating and Tubing Selection:

For working pressures of A-LOK® and CPI™ tube connections, please see the Instrument Tubing Selection Guide (Bulletin 4200-TS), found in the Technical Section of the Parker Instrumentation Products Master Binder, or the Parker Instrument Tube Fitting Installation Manual (Bulletin 4200-B4).

For working pressures of valves with external or internal pipe threads, please see Catalog 4260, Instrumentation Pipe Fittings.

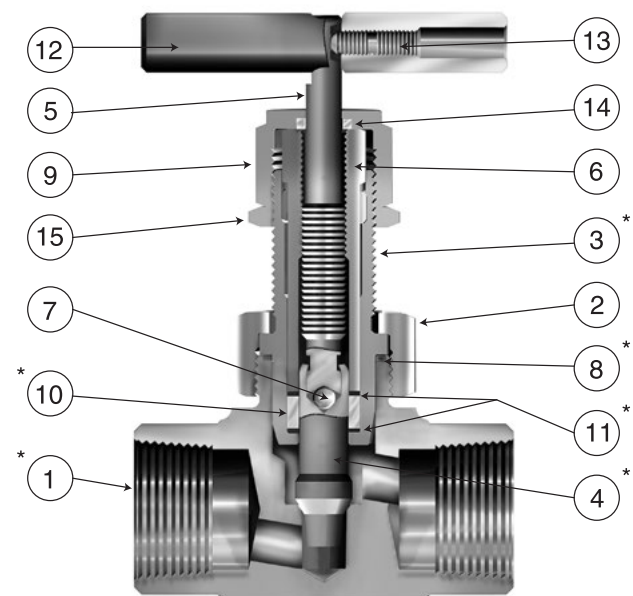

**Model Shown: 16F-U16LR-G-SS**

Grafoil® is a registered trademark GrafTech International Holdings, Inc.

## Pressure vs. Temperature

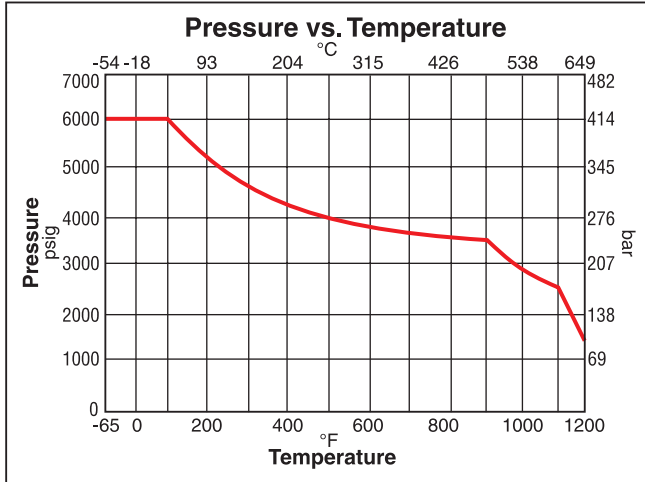

## Flow Characteristics

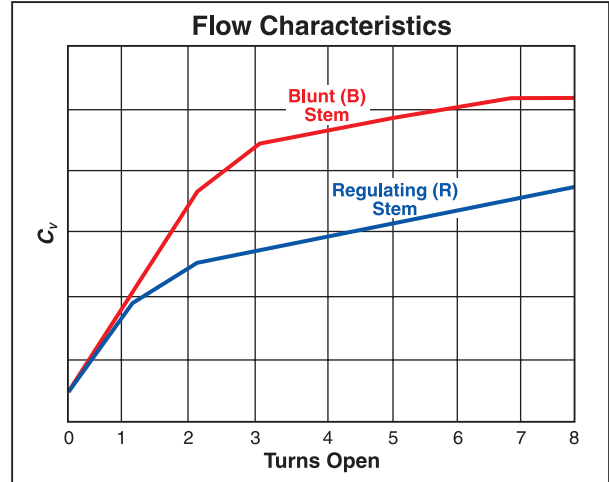

## U6 Series Dimensions / Flow Data

Model Shown:  
4Z-U6LB-T-SS

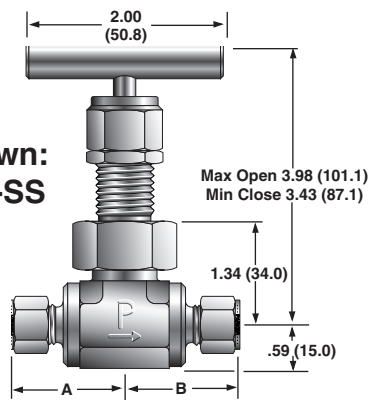

Panel Hole Diameter:  
0.65 (16.5)  
Max Panel Thickness:  
0.42 (10.7)

Model Shown:  
4F-U6AR-T-SS

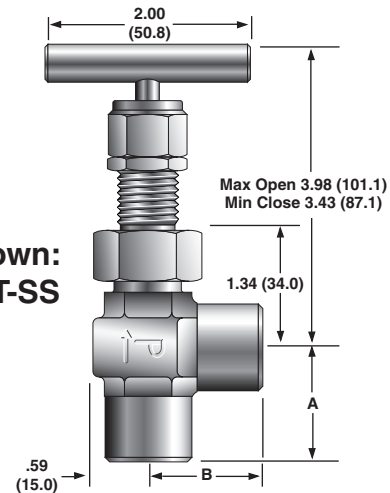

( ) Denotes dimensions  
in millimeters

Basic Part Number		End Connections		Stem Type	Flow Data				Dimensions					
Inline	Angle	Inlet (Port 1)	Outlet (Port 2)		Orifice		Angle		A†		B†			
					Inch	mm	Cv	X <sub>T</sub> *	Cv	X <sub>T</sub> *	Inch	mm	Inch	mm
2F-U6LR	2F-U6AR	1/8" Female NPT		Regulating	0.188	4.8	0.58	0.83	0.77	0.70	1.00	25.4	1.00	25.4
2F-U6LB	2F-U6AB			Blunt			0.69	0.50	0.91	0.42				
4A-U6LR	4A-U6AR	1/4" Compression A-LOK®		Regulating	0.177	4.5	0.53	0.80	0.70	0.67	1.38	35.1	1.38	35.1
4A-U6LB	4A-U6AB			Blunt			0.65	0.48	0.86	0.40				
4F-U6LR	4F-U6AR	1/4" Female NPT		Regulating	0.228	5.8	0.78	0.95	1.04	0.80	1.03	26.2	1.03	26.2
4F-U6LB	4F-U6AB			Blunt			0.82	0.59	1.09	0.50				
4M-U6LR	4M-U6AR	1/4" Male NPT		Regulating	0.177	4.5	0.53	0.80	0.70	0.67	1.09	27.7	1.09	27.7
4M-U6LB	4M-U6AB			Blunt			0.65	0.48	0.86	0.40				
4W-U6LR	4W-U6AR	1/4" Socket Weld		Regulating	0.177	4.5	0.53	0.80	0.70	0.67	.91	23.1	.91	23.1
4W-U6LB	4W-U6AB			Blunt			0.65	0.48	0.86	0.40				
4Z-U6LR	4Z-U6AR	1/4" Compression CPI™		Regulating	0.177	4.5	0.53	0.80	0.70	0.67	1.38	35.1	1.38	35.1
4Z-U6LB	4Z-U6AB			Blunt			0.65	0.48	0.86	0.40				
M6A-U6LR	M6A-U6AR	6mm Compression A-LOK®		Regulating	0.177	4.5	0.53	0.80	0.70	0.67	1.38	35.1	1.38	35.1
M6A-U6LB	M6A-U6AB			Blunt			0.65	0.48	0.86	0.40				
M6Z-U6LR	M6Z-U6AR	6mm Compression CPI™		Regulating	0.177	4.5	0.53	0.80	0.70	0.67	1.38	35.1	1.38	35.1
M6Z-U6LB	M6Z-U6AB			Blunt			0.65	0.48	0.86	0.40				
M8A-U6LR	M8A-U6AR	8mm Compression A-LOK®		Regulating	0.177	4.5	0.53	0.80	0.70	0.67	1.38	35.1	1.38	35.1
M8A-U6LB	M8A-U6AB			Blunt			0.65	0.48	0.86	0.40				
M8Z-U6LR	M8Z-U6AR	8mm Compression CPI™		Regulating	0.177	4.5	0.53	0.80	0.70	0.67	1.38	35.1	1.38	35.1
M8Z-U6LB	M8Z-U6AB			Blunt			0.65	0.48	0.86	0.40				

\* Tested in accordance with ISA S75.02. Gas flow will be choked when  $P_1 - P_2 / P_1 = X_T$ .  
 † For CPI™ and A-LOK®, dimensions are measured with nuts in the finger tight position.

Dimensions in inches/millimeters are for reference only, subject to change.

## U12 Series Dimensions / Flow Data

**Model Shown:**  
**6F-U12LB-G-SS-HT**

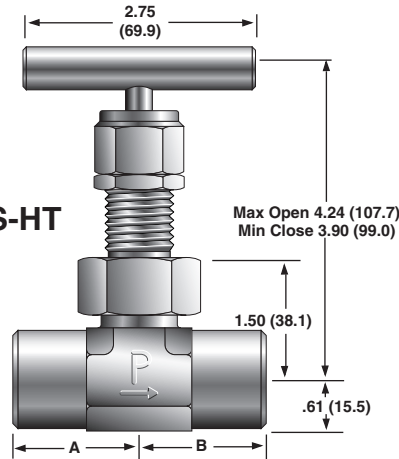

Panel Hole Diameter:  
0.83 (21.1)  
Max Panel Thickness:  
0.61 (15.5)

**Model Shown:**  
**8A-U12AB-T-SS**

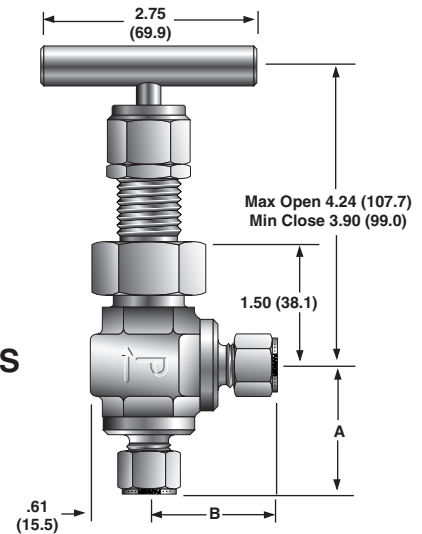

( ) Denotes dimensions in millimeters

Basic Part Number		End Connections		Stem Type	Flow Data				Dimensions					
Inline	Angle	Inlet (Port 1)	Outlet (Port 2)		Orifice	Inline		Angle		A†		B†		
					Inch	mm	$C_V$	$X_T^*$	$C_V$	$X_T^*$	Inch	mm	Inch	mm
4A-U12LR	4A-U12AR	1/4" Compression A-LOK®		Regulating	0.125	3.2	0.44	0.57	0.60	0.49	1.39	35.3	1.39	35.3
4A-U12LB	4A-U12AB			Blunt			0.51	0.40	0.68	0.33				
4F-U12LR	4F-U12AR	1/4" Female NPT		Regulating	0.250	6.4	0.94	0.65	1.25	0.55	1.13	28.7	1.13	28.7
4F-U12LB	4F-U12AB			Blunt			1.03	0.60	1.37	0.51				
4Z-U12LR	4Z-U12AR	1/4" Compression CPI™		Regulating	0.125	3.2	0.44	0.57	0.60	0.49	1.39	35.3	1.39	35.3
4Z-U12LB	4Z-U12AB			Blunt			0.51	0.40	0.68	0.33				
6A-U12LR	6A-U12AR	3/8" Compression A-LOK®		Regulating	0.187	4.7	0.69	0.61	0.92	0.52	1.60	40.6	1.60	40.6
6A-U12LB	6A-U12AB			Blunt			0.77	0.50	1.02	0.42				
6F-U12LR	6F-U12AR	3/8" Female NPT		Regulating	0.312	7.9	1.19	0.78	1.58	0.66	1.30	33.0	1.30	33.0
6F-U12LB	6F-U12AB			Blunt			1.31	0.80	1.74	0.68				
6W-U12LR	6W-U12AR	3/8" Tube Socket Weld		Regulating	0.228	5.8	0.85	0.64	1.13	0.54	1.13	28.7	1.13	28.7
6W-U12LB	6W-U12AB			Blunt			0.94	0.57	1.25	0.48				
6Z-U12LR	6Z-U12AR	3/8" Compression CPI™		Regulating	0.187	4.7	0.69	0.61	0.92	0.52	1.60	40.6	1.60	40.6
6Z-U12LB	6Z-U12AB			Blunt			0.77	0.50	1.02	0.42				
8A-U12LR	8A-U12AR	1/2" Compression A-LOK®		Regulating	0.250	6.4	0.94	0.65	1.25	0.55	1.49	37.8	1.49	37.8
8A-U12LB	8A-U12AB			Blunt			1.03	0.60	1.37	0.51				
8F-U12LR	8F-U12AR	1/2" Female NPT		Regulating	0.312	7.9	1.19	0.78	1.58	0.66	1.50	38.1	1.50	38.1
8F-U12LB	8F-U12AB			Blunt			1.31	0.80	1.74	0.68				
8W-U12LR	8W-U12AR	1/2" Tube Socket Weld		Regulating	0.312	7.9	1.19	0.78	1.58	0.66	1.25	31.8	1.25	31.8
8W-U12LB	8W-U12AB			Blunt			1.31	0.80	1.74	0.68				
8Z-U12LR	8Z-U12AR	1/2" Compression CPI™		Regulating	0.250	6.4	0.94	0.65	1.25	0.55	1.49	37.8	1.49	37.8
8Z-U12LB	8Z-U12AB			Blunt			1.03	0.60	1.37	0.51				
M10A-U12LR	M10A-U12AR	10mm Compression A-LOK®		Regulating	0.250	6.4	0.94	0.65	1.25	0.55	1.53	38.9	1.53	38.9
M10A-U12LB	M10A-U12AB			Blunt			1.03	0.60	1.37	0.51				
M10Z-U12LR	M10Z-U12AR	10mm Compression CPI™		Regulating	0.250	6.4	0.94	0.65	1.25	0.55	1.53	38.9	1.53	38.9
M10Z-U12LB	M10Z-U12AB			Blunt			1.03	0.60	1.37	0.51				
M12A-U12LR	M12A-U12AR	12mm Compression A-LOK®		Regulating	0.312	7.9	1.19	0.78	1.58	0.66	1.70	43.2	1.70	43.2
M12A-U12LB	M12A-U12AB			Blunt			1.31	0.80	1.74	0.68				
M12Z-U12LR	M12Z-U12AR	12mm Compression CPI™		Regulating	0.312	7.9	1.19	0.78	1.58	0.66	1.70	43.2	1.70	43.2
M12Z-U12LB	M12Z-U12AB			Blunt			1.31	0.80	1.74	0.68				
M14A-U12LR	M14A-U12AR	14mm Compression A-LOK®		Regulating	0.312	7.9	1.19	0.78	1.58	0.66	1.70	43.2	1.70	43.2
M14A-U12LB	M14A-U12AB			Blunt			1.31	0.80	1.74	0.68				
M14Z-U12LR	M14Z-U12AR	14mm Compression CPI™		Regulating	0.312	7.9	1.19	0.78	1.58	0.66	1.70	43.2	1.70	43.2
M14Z-U12LB	M14Z-U12AB			Blunt			1.31	0.80	1.74	0.68				

\* Tested in accordance with ISA S75.02. Gas flow will be choked when  $P_1 - P_2 / P_1 = X_T$ .  
† For CPI™ and A-LOK®, dimensions are measured with nuts in the finger tight position.

Dimensions in inches/millimeters are for reference only, subject to change.



## U16 Series Dimensions / Flow Data

**Model Shown:**  
**16M-U16LR-G-SS**

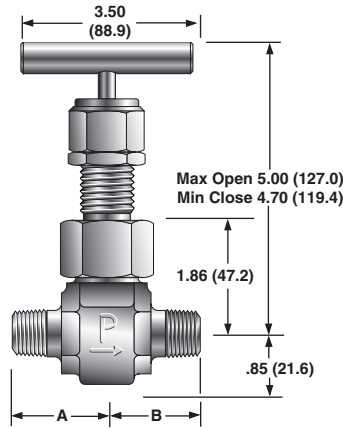

Panel Hole Diameter:  
1.02 (25.9)  
Max Panel Thickness:  
0.62 (15.7)

**Model Shown:**  
**16M16F-U16AB-T-SS**

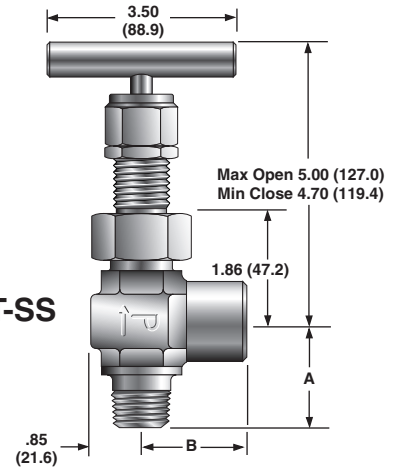

( ) Denotes dimensions  
in millimeters

Basic Part Number		End Connections		Stem Type	Flow Data				Dimensions					
Inline	Angle	Inlet (Port 1)	Outlet (Port 2)		Orifice	Inline		Angle		A†		B†		
					Inch	mm	$C_V$	$X_T^*$	$C_V$	$X_T^*$	Inch	mm	Inch	mm
8A-U16LR	8A-U16AR	1/2" Compression A-LOK®		Regulating	0.394	10.0	1.59	0.73	2.11	0.62	1.97	50.0	1.97	50.0
8A-U16LB	8A-U16AB			Blunt			1.90	0.95	2.53	0.81				
8F-U16LR	8F-U16AR	1/2" Female NPT		Regulating	0.437	11.1	1.82	0.72	2.42	0.61	1.56	39.6	1.56	39.6
8F-U16LB	8F-U16AB			Blunt			2.67	0.80	3.55	0.68				
8M-U16LR	8M-U16AR	1/2" Male NPT		Regulating	0.437	11.1	1.82	0.72	2.42	0.61	1.92	48.8	1.92	48.8
8M-U16LB	8M-U16AB			Blunt			2.67	0.80	3.55	0.68				
8PSW-U16LR	8PSW-U16AR	1/2" Pipe Socket Weld		Regulating	0.437	11.1	1.82	0.72	2.42	0.61	1.56	39.6	1.56	39.6
8PSW-U16LB	8PSW-U16AB			Blunt			2.67	0.80	3.55	0.68				
8W-U16LR	8W-U16AR	1/2" Tube Socket Weld		Regulating	0.394	10.0	1.59	0.73	2.11	0.62	1.69	42.9	1.69	42.9
8W-U16LB	8W-U16AB			Blunt			1.90	0.95	2.53	0.81				
8Z-U16LR	8Z-U16AR	1/2" Compression CPI™		Regulating	0.394	10.0	1.59	0.73	2.11	0.62	1.97	50.0	1.97	50.0
8Z-U16LB	8Z-U16AB			Blunt			1.90	0.95	2.53	0.81				
12A-U16LR	12A-U16AR	3/4" Compression A-LOK®		Regulating	0.437	11.1	1.82	0.72	2.42	0.61	1.97	50.0	1.97	50.0
12A-U16LB	12A-U16AB			Blunt			2.67	0.80	3.55	0.68				
12F-U16LR	12F-U16AR	3/4" Female NPT		Regulating	0.437	11.1	1.82	0.72	2.42	0.61	1.63	41.4	1.63	41.4
12F-U16LB	12F-U16AB			Blunt			2.67	0.80	3.55	0.68				
12M-U16LR	12M-U16AR	3/4" Male NPT		Regulating	0.437	11.1	1.82	0.72	2.42	0.61	1.63	41.4	1.63	41.4
12M-U16LB	12M-U16AB			Blunt			2.67	0.80	3.55	0.68				
12PSW-U16LR	12PSW-U16AR	3/4" Pipe Socket Weld		Regulating	0.437	11.1	1.82	0.72	2.42	0.61	1.56	39.6	1.56	39.6
12PSW-U16LB	12PSW-U16AB			Blunt			2.67	0.80	3.55	0.68				
12W-U16LR	12W-U16AR	3/4" Tube Socket Weld		Regulating	0.437	11.1	1.82	0.72	2.42	0.61	1.56	39.6	1.56	39.6
12W-U16LB	12W-U16AB			Blunt			2.67	0.80	3.55	0.68				
12Z-U16LR	12Z-U16AR	3/4" Compression CPI™		Regulating	0.437	11.1	1.82	0.72	2.42	0.61	1.97	50.0	1.97	50.0
12Z-U16LB	12Z-U16AB			Blunt			2.67	0.80	3.55	0.68				
16A-U16LR	16A-U16AR	1" Compression A-LOK®		Regulating	0.437	11.1	1.82	0.72	2.42	0.61	1.97	50.0	1.97	50.0
16A-U16LB	16A-U16AB			Blunt			2.67	0.80	3.55	0.68				
16F-U16LR	16F-U16AR	1" Female NPT		Regulating	0.437	11.1	1.82	0.72	2.42	0.61	1.81	46.0	1.81	46.0
16F-U16LB	16F-U16AB			Blunt			2.67	0.80	3.55	0.68				
16M-U16LR	16M-U16AR	1" Male NPT		Regulating	0.437	11.1	1.82	0.72	2.42	0.61	1.81	46.0	1.81	46.0
16M-U16LB	16M-U16AB			Blunt			2.67	0.80	3.55	0.68				
16Z-U16LR	16Z-U16AR	1" Compression CPI™		Regulating	0.437	11.1	1.82	0.72	2.42	0.61	1.97	50.0	1.97	50.0
16Z-U16LB	16Z-U16AB			Blunt			2.67	0.80	3.55	0.68				
M12A-U16LR	M12A-U16AR	12mm Compression A-LOK®		Regulating	0.394	10.0	1.59	0.73	2.11	0.62	1.97	50.0	1.97	50.0
M12A-U16LB	M12A-U16AB			Blunt			1.90	0.95	2.53	0.81				
M12Z-U16LR	M12Z-U16AR	12mm Compression CPI™		Regulating	0.394	10.0	1.59	0.73	2.11	0.62	1.97	50.0	1.97	50.0
M12Z-U16LB	M12Z-U16AB			Blunt			1.90	0.95	2.53	0.81				
M20A-U16LR	M20A-U16AR	20mm Compression A-LOK®		Regulating	0.437	11.1	1.82	0.72	2.42	0.61	1.97	50.0	1.97	50.0
M20A-U16LB	M20A-U16AB			Blunt			2.67	0.80	3.55	0.68				
M20Z-U16LR	M20Z-U16AR	20mm Compression CPI™		Regulating	0.437	11.1	1.82	0.72	2.42	0.61	1.97	50.0	1.97	50.0
M20Z-U16LB	M20Z-U16AB			Blunt			2.67	0.80	3.55	0.68				
M25A-U16LR	M25A-U16AR	25mm Compression A-LOK®		Regulating	0.437	11.1	1.82	0.72	2.42	0.61	1.97	50.0	1.97	50.0
M25A-U16LB	M25A-U16AB			Blunt			2.67	0.80	3.55	0.68				
M25Z-U16LR	M25Z-U16AR	25mm Compression CPI™		Regulating	0.437	11.1	1.82	0.72	2.42	0.61	1.97	50.0	1.97	50.0
M25Z-U16LB	M25Z-U16AB			Blunt			2.67	0.80	3.55	0.68				

\* Tested in accordance with ISA S75.02. Gas flow will be choked when  $P_1 - P_2 / P_1 = X_T$ .

† For CPI™ and A-LOK®, dimensions are measured with nuts in the finger tight position.

Dimensions in inches/millimeters are for reference only, subject to change.

## How to Order

Dimensions in inches/millimeters are for reference only, subject to change.

The correct part number is easily derived from the following example and ordering chart. The six product characteristics required are coded as shown in the chart.

The example below describes an angle pattern U6 Series needle valve equipped with 1/4" CPI™ compression inlet and outlet ports, a regulating stem type, Grafoil® packing, stainless steel construction.

### Example 1: 4Z-U6AR-G-SS

4Z		-		U6A		R		-		G		-		SS	
Inlet Port*		Outlet Port*		Valve Series		Stem Type		Packing		Body Material					
2F	4F	4W	M6A	M8	U6A	B	Blunt	T	PTFE	SS	Stainless Steel				
4A	4M	4Z	M6Z	M8Z	U6L	R	Regulating	G	Grafoil®						
4A	6W	8W	12A	M12A	U12A										
4F	6Z	8Z	12Z	M12Z	U12L										
4Z	8A	10A	M10A	M14A											
6A	8F	10Z	M10Z	M14Z											
6F															
8A	8W	12PSW	16M	M20Z	U16A										
8F	8Z	12W	16Z	M25A	U16L										
8M	12F	12Z	M12Z	M25Z											
8PSW	12M	16F	M20A												

\*If the inlet and outlet ports are the same, eliminate the outlet port designator.

## How to Order Options

**High Temperature** – Add the suffix **-HT** to the end of the part number to receive valves with a 316 stainless steel lower stem and stainless steel handle. **Example:** 4M-U6LB-G-SS-HT

**Oxygen Cleaning** – Add the suffix **-C3** to the end of the part number to receive valves cleaned and assembled for oxygen service in accordance with Parker Specification ES8003. **Example:** 8A-U12LR-T-SS-C3

**Stainless Steel Bar Handle** – To obtain valves with stainless steel bar handle, add the suffix **-ST** to the end of the part number. **Example:** 12Z-U16AB-T-SS-ST

**ASME B31.1 Compliant Valves** – Add the suffix **-QC311**. **Example:** 8F-U12LR-G-SS-QC311

## How to Order Maintenance Kits

**Stainless Steel T-Bar Handles with Handle Screw** – **Examples:** U6: V4-BAR-HANDLE-SS; U12: U12-BAR-HANDLE-SS; U16: U16-BAR-HANDLE-SS

**Aluminum T-Bar Handles with Handle Screw** – **Examples:** U6: V4-BAR-HANDLE-AL; U12: U12-BAR-HANDLE-AL; U16: U16-BAR-HANDLE-AL

**Panel Mounting Nuts** – **Examples:** U6: U6-LOCKNUT; U12: U12-LOCKNUT; U16: U16-LOCKNUT

**PTFE Packing Kits** – Consists of One PTFE Packing; One Dust Seal; Maintenance Instructions. Kit-Valve Series-T. **Example:** KIT-U12-T

**Grafoil® Packing Kits** – Consists of One Grafoil® Packing; One Dust Seal; Maintenance Instructions. Kit-Valve Series-G. **Example:** KIT-U16-G

Grafoil® is a registered trademark GrafTech International Holdings, Inc.



## Introduction

Parker VQ Series Toggle Valves are the right combination of performance and value for manual or pneumatic on-off control in moderate pressure and temperature applications. The manual version employs a toggle handle for quick action at pressures up to 300 psig (21 bar). Compact double acting, normally closed, and normally open pneumatically actuated versions of this valve are ideal for automatic control at pressures up to 600 psig (41 bar).

## Manual Toggle Valve Features

- ▶ Quick acting
- ▶ Inline and angle patterns
- ▶ Available with CPI™, A-LOK®, male and female NPT end connections
- ▶ Panel mountable
- ▶ Color-coded handles
- ▶ 316 stainless steel and brass body construction
- ▶ Stem seal materials –
  - Fluorocarbon Rubber
  - Nitrile Rubber
  - Ethylene Propylene Rubber
  - Highly Fluorinated Fluorocarbon Rubber
- ▶ Optional handle positioners and anti-lock handles
- ▶ 100% factory tested

## Manual Toggle Valve Specifications

### Pressure Rating at All Temperatures:

300 psig (21 bar) CWP

### Temperature Ratings:

PTFE Stem Tip: -20°F to 200°F (-29°C to 93°C)

PCTFE Stem Tip: -65°F to 200°F (-54°C to 93°C)

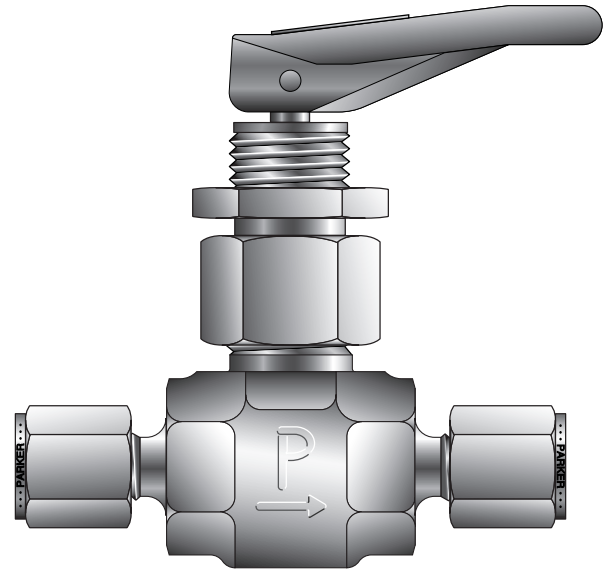

**Model Shown:  
4A-V4LQ-BP**

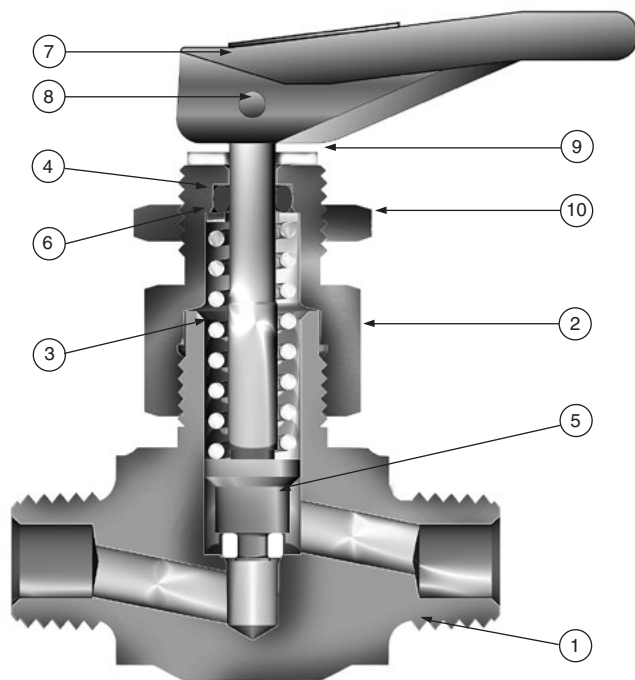

**Model Shown: 4M-V4LQ-SSP**

## Materials of Construction Manual Toggle Valve

Item #	Description	Stainless Steel	Brass
1	Body	ASTM A 182 Type F316	ASTM B 283 Alloy C37700
2	Cap	ASTM A 479 Type 316	ASTM B 453 Alloy C34000
3	Spring	Stainless Steel	Stainless Steel
4	Stem Seal*	Fluorocarbon Rubber	Fluorocarbon Rubber
5	Stem	ASTM A 276 Type 316	ASTM A 276 Type 316
6	Stem Washer	Stainless Steel	Stainless Steel
7	Handle	Nylon 6/6	Nylon 6/6
8	Handle Pin	Stainless Steel	Stainless Steel
9	Handle Washer	Acetal	Acetal
10	Panel Nut	316 Stainless Steel	316 Stainless Steel

\* Optional stem seal materials available - [See How to Order](#)  
Lubrication: Perfluorinated polyether

## Actuated Valve Features

- ▶ Available in normally open, normally closed, and double acting models
- ▶ Inline and angle patterns
- ▶ Available with CPI™, A-LOK®, male and female NPT end connections
- ▶ Mounting bracket standard
- ▶ 316 stainless steel and brass body construction
- ▶ Stem seal materials -
  - Fluorocarbon Rubber
  - Nitrile Rubber
  - Ethylene Propylene Rubber
  - Highly Fluorinated Fluorocarbon Rubber
- ▶ 100% factory tested

## Actuated Valve Specifications

### Pressure Rating at All Temperatures:

- Size VQ4 Normally Closed:
  - 600 psig (41 bar) CWP
- Size VQ6 Normally Closed:
  - 500 psig (35 bar) CWP
- Normally Open:
  - 450 psig (31 bar) CWP
- Double Acting:
  - 450 psig (31 bar) CWP

### Temperature Ratings:

- PTFE Stem Tip: -20°F to 200°F (-29°C to 93°C)
- PCTFE Stem Tip: -65°F to 200°F (-54°C to 93°C)

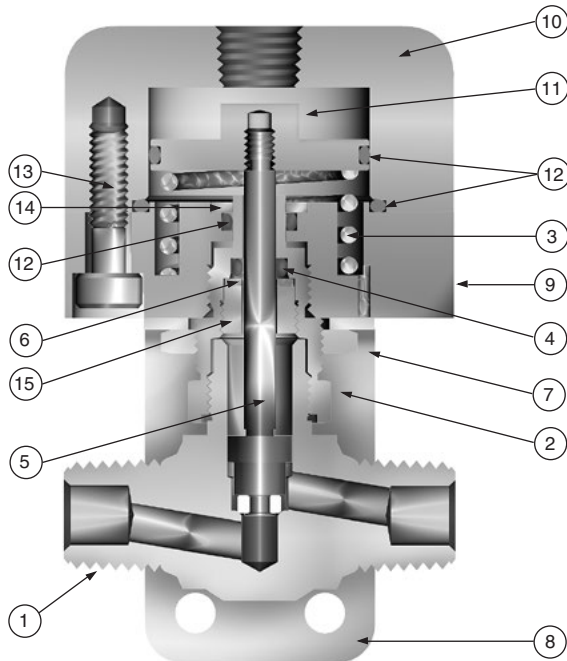

**Model Shown:**  
**4M-V4LQ-11AO-SS**

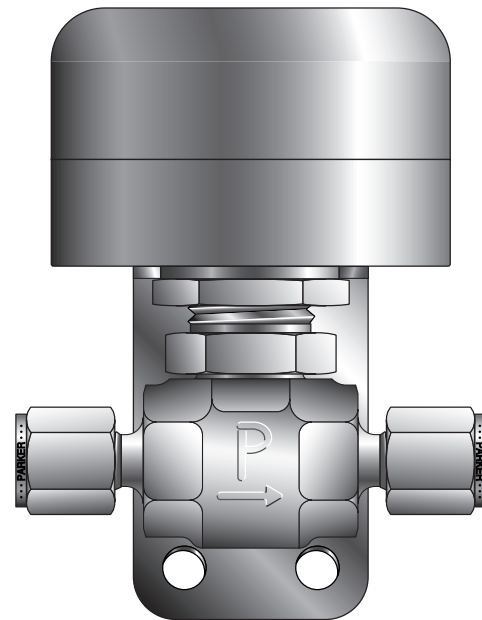

**Model Shown:**  
**M6A-V4LQ-BN-11AC-SS**

VQ

## Materials of Construction Actuated Valve

Item #	Description	Stainless Steel	Brass
1	Body	ASTM A 182 Type F316	ASTM B 283 Alloy C37700
2	Cap	ASTM A 479 Type 316	ASTM B 453 Alloy C34000
3	Spring*	Stainless Steel	Stainless Steel
4	Stem Seal**	Fluorocarbon Rubber	Fluorocarbon Rubber
5	Stem	ASTM A 276 Type 316	ASTM A 276 Type 316
6	Stem Washer	Stainless Steel	Stainless Steel
7	Lock Nut	316 Stainless Steel	316 Stainless Steel
8	Mounting Bracket	Aluminum	Aluminum
9	Actuator Base	Aluminum	Aluminum
10	Actuator Cap	Aluminum	Aluminum
11	Piston	Aluminum	Aluminum
12	Actuator Seals	Fluorocarbon Rubber	Fluorocarbon Rubber
13	Screws	Stainless Steel	Stainless Steel
14	Actuator Bushing	Aluminum	Aluminum
15	Stem Bushing***	ASTM A 479 Type 316	ASTM A 479 Type 316

\* Spring not used on Double Acting (11AD) models

\*\* Optional stem seal materials available - [See How to Order](#)

\*\*\* Stem Bushing not used on Normally Closed (11AC) models  
Lubrication: Perfluorinated polyether

## VQ4 Dimensions / Flow Data

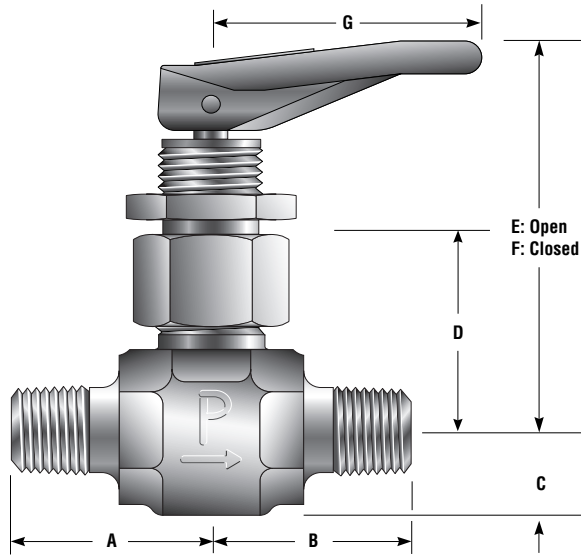

Model Shown: 4M-V4LQ-SSP

( ) Denotes dimensions in millimeters

Panel Hole Diameter:  
VQ4: 0.52 (13.2)  
VQ6: 0.65 (16.5)  
Max. Panel Thickness:  
VQ4: 0.25 (6.4)  
VQ6: 0.35 (8.9)

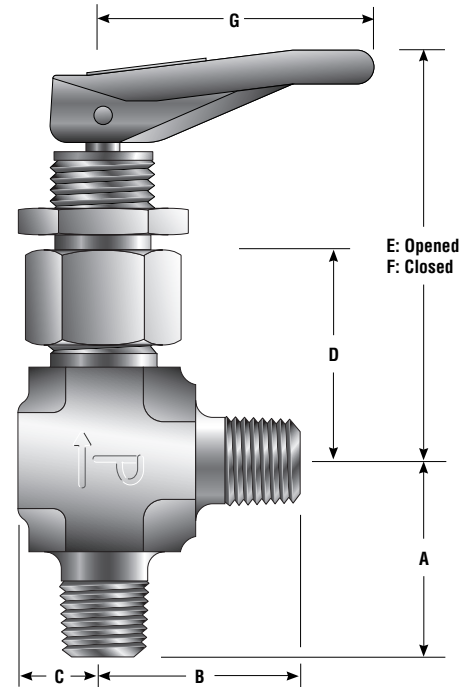

Model Shown: 4M-V4AQ-EPR-SSP

## VQ4 Dimensions / Flow Data

Basic Part Number	End Connections		Flow Data				Dimensions													
	Inlet (Port 1)	Outlet (Port 2)	Orifice		$C_v$	$X_T^*$	A†		B†		C		D		E		F		G	
			Inch	mm			Inch	mm	Inch	mm	Inch	mm	Inch	mm	Inch	mm	Inch	mm	Inch	mm
2A-V4LQ	1/8" Compression A-LOK®		0.078	2.0	0.14	0.52	1.10	27.9	1.10	27.9	0.41	10.4	0.93	23.6	2.88	73.2	1.84	46.7	1.25	31.8
2A-V4AQ					0.15	0.50														
2F-V4LQ	1/8" Female NPT		0.176	4.5	0.36	0.71	0.81	20.6	0.81	20.6	0.41	10.4	0.93	23.6	2.88	73.2	1.84	46.7	1.25	31.8
2F-V4AQ					0.49	0.64														
2M-V4LQ	1/8" Male NPT		0.125	3.2	0.30	0.50	0.81	20.6	0.81	20.6	0.41	10.4	0.93	23.6	2.88	73.2	1.84	46.7	1.25	31.8
2M-V4AQ					0.35	0.55														
2Z-V4LQ	1/8" Compression CPI™		0.078	2.0	0.14	0.52	1.10	27.9	1.10	27.9	0.41	10.4	0.93	23.6	2.88	73.2	1.84	46.7	1.25	31.8
2Z-V4AQ					0.15	0.50														
4A-V4LQ	1/4" Compression A-LOK®		0.176	4.5	0.36	0.71	1.15	29.2	1.15	29.2	0.41	10.4	0.93	23.6	2.88	73.2	1.84	46.7	1.25	31.8
4A-V4AQ					0.49	0.64														
4M-V4LQ	1/4" Male NPT		0.176	4.5	0.36	0.71	0.94	23.9	0.94	23.9	0.41	10.4	0.93	23.6	2.88	73.2	1.84	46.7	1.25	31.8
4M-V4AQ					0.49	0.64														
4Z-V4LQ	1/4" Compression CPI™		0.176	4.5	0.36	0.71	1.15	29.2	1.15	29.2	0.41	10.4	0.93	23.6	2.88	73.2	1.84	46.7	1.25	31.8
4Z-V4AQ					0.49	0.64														
6A-V4LQ	3/8" Compression A-LOK®		0.176	4.5	0.36	0.71	1.17	29.7	1.17	29.7	0.41	10.4	0.93	23.6	2.88	73.2	1.84	46.7	1.25	31.8
6A-V4AQ					0.49	0.64														
6Z-V4LQ	3/8" Compression CPI™		0.176	4.5	0.36	0.71	1.17	29.7	1.17	29.7	0.41	10.4	0.93	23.6	2.88	73.2	1.84	46.7	1.25	31.8
6Z-V4AQ					0.49	0.64														
M6A-V4LQ	6mm Compression A-LOK®		0.176	4.5	0.36	0.71	1.13	28.7	1.13	28.7	0.41	10.4	0.93	23.6	2.88	73.2	1.84	46.7	1.25	31.8
M6A-V4AQ					0.49	0.64														
M6Z-V4LQ	6mm Compression CPI™		0.176	4.5	0.36	0.71	1.13	28.7	1.13	28.7	0.41	10.4	0.93	23.6	2.88	73.2	1.84	46.7	1.25	31.8
M6Z-V4AQ					0.49	0.64														
M8A-V4LQ	8mm Compression A-LOK®		0.176	4.5	0.36	0.71	1.13	28.7	1.13	28.7	0.41	10.4	0.93	23.6	2.88	73.2	1.84	46.7	1.25	31.8
M8A-V4AQ					0.49	0.64														
M8Z-V4LQ	8mm Compression CPI™		0.176	4.5	0.36	0.71	1.13	28.7	1.13	28.7	0.41	10.4	0.93	23.6	2.88	73.2	1.84	46.7	1.25	31.8
M8Z-V4AQ					0.49	0.64														

\* Tested in accordance with ISA S75.02. Gas flow will be choked when  $P_1 - P_2 / P_1 = X_T$ .

† For CPI™ and A-LOK®, dimensions are measured with nuts in the finger tight position.

Dimensions in inches/millimeters are for reference only, subject to change.

## VQ6 Dimensions / Flow Data

Basic Part Number	End Connections		Flow Data				Dimensions													
	Inlet (Port 1)	Outlet (Port 2)	Orifice		$C_v$	$X_T^*$	A†		B†		C		D		E		F		G	
			Inch	mm			Inch	mm	Inch	mm	Inch	mm	Inch	mm	Inch	mm	Inch	mm	Inch	mm
4F-V6LQ	1/4" Female NPT		0.250	6.4	0.83	0.70	1.00	25.4	1.00	25.4	0.53	13.5	1.07	27.2	3.45	87.6	2.13	54.1	1.60	40.6
4F-V6AQ																				
6A-V6LQ	3/8" Compression A-LOK®		0.250	6.4	0.83	0.70	1.29	32.8	1.29	32.8	0.53	13.5	1.07	27.2	3.45	87.6	2.13	54.1	1.60	40.6
6A-V6AQ																				
6Z-V6LQ	3/8" Compression CPI™		0.250	6.4	0.83	0.70	1.29	32.8	1.29	32.8	0.53	13.5	1.07	27.2	3.45	87.6	2.13	54.1	1.60	40.6
6Z-V6AQ																				
8A-V6LQ	1/2" Compression A-LOK®		0.250	6.4	0.83	0.70	1.37	34.8	1.37	34.8	0.53	13.5	1.07	27.2	3.45	87.6	2.13	54.1	1.60	40.6
8A-V6AQ																				
8Z-V6LQ	1/2" Compression CPI™		0.250	6.4	0.83	0.70	1.37	34.8	1.37	34.8	0.53	13.5	1.07	27.2	3.45	87.6	2.13	54.1	1.60	40.6
8Z-V6AQ																				
M10A-V6LQ	10mm Compression A-LOK®		0.250	6.4	0.83	0.70	1.30	33.0	1.30	33.0	0.53	13.5	1.07	27.2	3.45	87.6	2.13	54.1	1.60	40.6
M10A-V6AQ																				
M10Z-V6LQ	10mm Compression CPI™		0.250	6.4	0.83	0.70	1.30	33.0	1.30	33.0	0.53	13.5	1.07	27.2	3.45	87.6	2.13	54.1	1.60	40.6
M10Z-V6AQ																				

\* Tested in accordance with ISA S75.02. Gas flow will be choked when  $P_1 - P_2 / P_1 = X_T$ .  
 † For CPI™ and A-LOK®, dimensions are measured with nuts in the finger tight position.

Dimensions in inches/millimeters are for reference only, subject to change.

VQ

## Pneumatically Actuated Valves

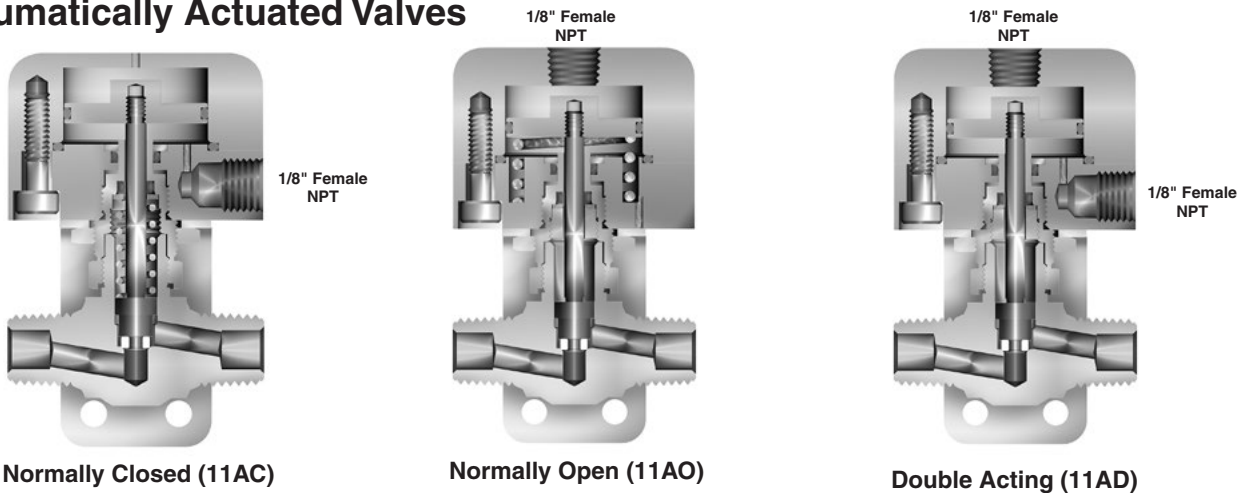

## Minimum Actuating Pressures

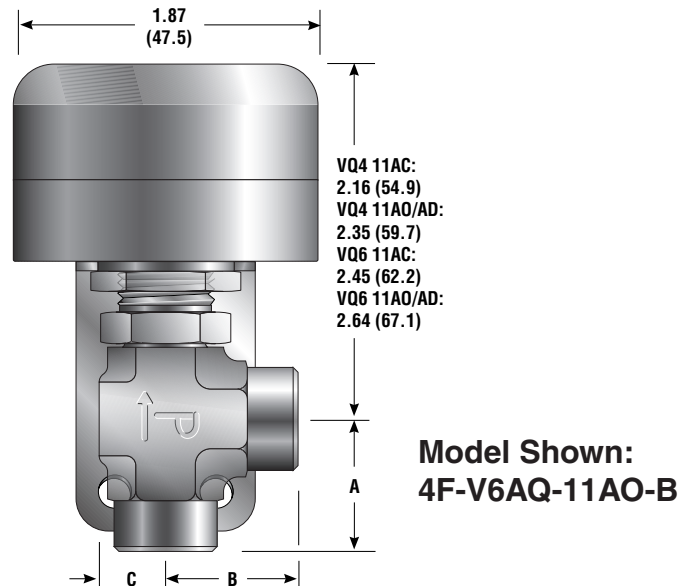
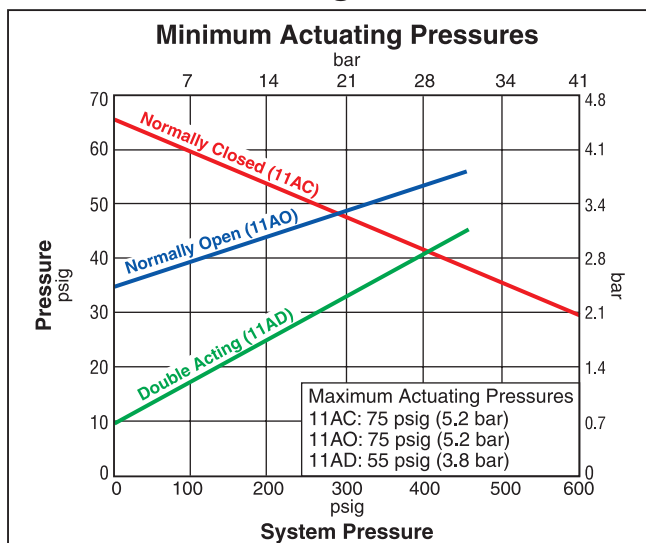

## VQ4 Valve Mounting Bracket

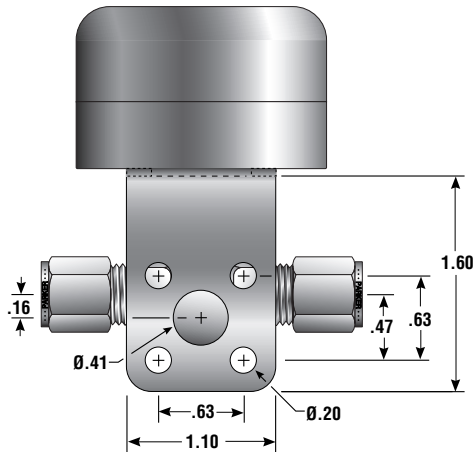

## VQ6 Valve Mounting Bracket

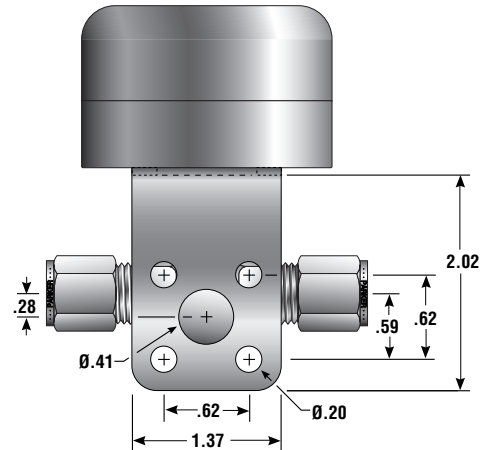

VQ

## How to Order Manual Toggle Valves

Dimensions in inches/millimeters are for reference only, subject to change.

The correct part number is easily derived from the following example and ordering chart. The six product characteristics required are coded as shown in the chart.

The example below describes a VQ4 Series inline pattern toggle valve equipped with 1/4" CPI™ compression inlet and outlet ports, PCTFE stem tip, Nitrile rubber stem seal, and stainless steel construction with panel mounting nut.

### Example 1: 4Z-V4LQK-BN-SSP

4Z		-		V4LQ		K		-		BN		-		SSP	
Inlet Port*		Outlet Port*		Valve Series		Stem Tip				Stem Seal				Body Material	
Inlet Port*		Outlet Port*		Valve Series		Stem Tip				Stem Seal				Body Material	
2A	4A	6A	M6A	V4LQ	Blank	PTFE	Blank	Fluorocarbon	SSP	Stainless					
2F	4M	6Z	M6Z	V4AQ	K	PCTFE		Rubber		Steel with					
2M	4Z		M8A				BN	Nitrile Rubber		Panel Nut					
2Z			M8Z				EPR	Ethylene Propylene Rubber	BP	Brass with					
4F	6A	8A	M10A	V6LQ			KZ	Highly Fluorinated Fluorocarbon Rubber		Panel Nut					
	6Z	8Z	M10Z	V6AQ											

\*If the inlet and outlet ports are the same, eliminate the outlet port designator.



## How to Order Actuated Valves

Dimensions in inches/millimeters are for reference only, subject to change.

The correct part number is easily derived from the following example and ordering chart. The seven product characteristics required are coded as shown in the chart.

The example below describes a VQ4 Series pneumatically actuated (normally closed) angle pattern valve equipped with a 1/4" Male NPT inlet port, a 1/4" A-LOK® compression outlet port, PTFE stem tip, fluorocarbon rubber stem seal, brass construction with mounting bracket.

### Example 1: 4M4A-V4AQ-11AC-B

4M		4A		-		V4AQ		-		11AC		-		B	
Inlet Port*		Outlet Port*		Valve Series		Stem Tip		Stem Seal		Actuator Type		Body Material			
Inlet Port*		Outlet Port*		Valve Series		Stem Tip		Stem Seal		Actuator Type		Body Material			
2A	4A	6A	M6A	V4LQ		Blank	PTFE	Blank	Fluorocarbon Rubber	11AC	Normally Closed	SS	Stainless Steel		
2F	4M	6Z	M6Z	V4AQ		K	PCTFE	BN	Nitrile Rubber	11AO	Normally Opened	B	Brass		
2M	4Z	M8A		V6LQ V6AQ				EPR	Ethylene Propylene Rubber	11AD	Double Acting				
2Z	M8Z														
4F	6A	8A	M10A	V6LQ V6AQ				KZ	Highly Fluorinated Fluorocarbon Rubber						
	6Z	8Z	M10Z												

\*If the inlet and outlet ports are the same, eliminate the outlet port designator.

## How to Order Options

**Colored Nylon Handles** – Add the designator corresponding to the correct handle color as a suffix to the part number. Black is standard, **W** - white, **B** - blue, **G** - green, **R** - red, **Y** - yellow. **Example:** M10A-V6LQ-SSP-**G**

**Anti-locking Handles** – Prevents the handle from locking in the open position. Add **-ALH** as a suffix to the part number. **Example:** 4M4F-V4LQ-BN-SSP-**ALH**

**Handle Positioner** – Aids in keeping the handle from rotating away from a desired position. To order, add the suffix **-Q4** or **-Q6** to the end of the part number. **Example:** 4M4F-V6LQ-EPR-SSP-**Q6**

**Oxygen Cleaning** – Add the suffix **-C3** to the end of the part number to receive valves cleaned and assembled for oxygen service in accordance with Parker Specification ES8003. **Example:** 4A-V4AQ-EPR-SSP-**C3**

## How to Order Maintenance Kits

**Colored Nylon Handles with Handle Pin** – Valve Series-Handle-Color. **Example:** V4Q-HANDLE-BLUE

**Handle Positioners** – Enables the user to position the handle in a desired location and prevents it from rotating. **Examples:** VQ4: VQ4-HANDLE-POSITIONER; VQ6: VQ6-HANDLE-POSITIONER

**Rubber Seal and Stem Kits** – Consists of one Stem, one Rubber O-ring Stem Seal; one Packing Washer, one Handle Pin, Maintenance Instructions, Kit-Valve Series and Stem Tip-Seal Material.

**Examples:** KIT-VQ4-BN; KIT-VQ6K-V

## Introduction

Parker NP6 Needle Valves are designed with packing below the stem threads and a two-piece stem. The packing below the threads protects the flow stream from thread lubricant contamination or washout and also protects the stem threads from potential damaging effects of the media. The two-piece stem produces a non-rotating lower stem for superior, repeatable sealing and reduced packing wear.

## Features

- ▶ Packing below power threads protects thread lubricants from media and isolates the media from the lubricant for severe service applications
- ▶ O-ring dust seal in bonnet protects stem threads from external contamination
- ▶ Choice of two non-rotating stem types:
  - R-Stem – All metal, blunt stem tip
  - K-Stem – PCTFE stem tip
- ▶ Non rotating lower stem extends packing and valve life
- ▶ 316 stainless steel construction
- ▶ Inline and angle patterns
- ▶ Wide variety of US Customary and SI ports
- ▶ Panel mountable
- ▶ 100% factory tested
- ▶ Optional color coded handles

## Specifications

### Pressure Rating:

6000 psig (414 bar) CWP

### Temperature Rating:

PTFE Packing:

-65°F to 450°F (-54°C to 232°C)

PCTFE:

-65°F to 350°F (-54°C to 177°C)

Nitrile Rubber:

-30°F to 250°F (-34°C to 121°C)

Ethylene Propylene Rubber:

-70°F to 275°F (-57°C to 135°C)

Fluorocarbon Rubber:

-15°F to 400°F (-26°C to 204°C)

Grafoil®:

-70°F to 700°F (-57°C to 371°C)

NP6

## Materials of Construction

Item #	Description	Material
1	Body	ASTM A 182 Type F316
2	Packing Nut	ASTM A 479 Type 316
3	Lower Stem (R-Stem)	ASTM A 276 Type 316
3	Lower Stem (K-Stem)	ASTM A 276 Type 316, with PCTFE
4	Upper Stem	ASTM A 276 Type 316
5	Packing Gland	ASTM A 276 Type 316
6	Packing*	PTFE
7	Packing Washer	Stainless Steel
8	Handle**	Nylon 6/6, with SS Insert
9	Handle Screw	Stainless Steel
10	Packing Nut Screw	Stainless Steel
11	Dust Seal	Fluorocarbon Rubber
12	Panel Nut	316 Stainless Steel

\* Optional elastomeric stem seals and Grafoil® packing are available -  
[See How to Order.](#)

\*\* Handles for Grafoil® packed valves are aluminum T-bars.  
Lubrication: Perfluorinated polyether

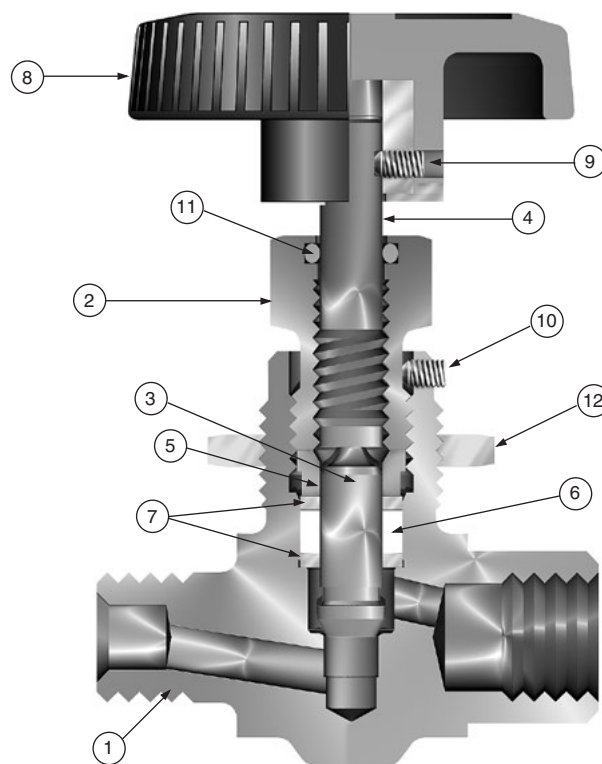

Model Shown: 4M4F-NP6LR-SSP

Grafoil® is a registered trademark of GrafTech International Holdings, Inc.

## Dimensions / Flow Data

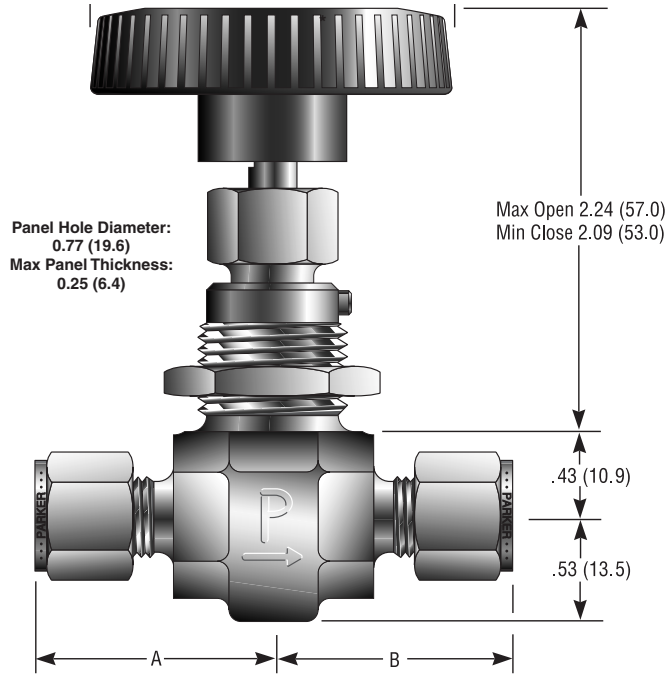

**Model Shown: 4Z-NP6LK-SSP**

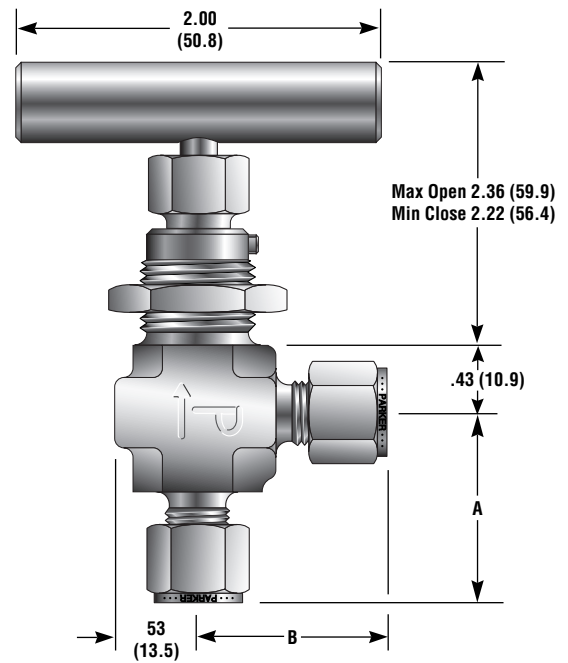

**Model Shown: 4Z-NP6AR-G-SSP**

\* Note: Handle diameter for R Stem NP6 Series Valves is 1.81 (46.0)

( ) Denotes dimensions in millimeters

Basic Part Number		End Connections		Stem Type	Flow Data				Dimensions					
Inline	Angle	Inlet (Port 1)	Outlet (Port 2)		Orifice		Inline		Angle		A†		B†	
					Inch	mm	C <sub>v</sub>	X <sub>T</sub> *	C <sub>v</sub>	X <sub>T</sub> *	Inch	mm	Inch	mm
4A-NP6LR	4A-NP6AR	1/4" Compression A-LOK®		Blunt	0.177	4.5	0.60	0.50	0.67	0.39	1.20	30.5	1.20	30.5
4A-NP6LK	4A-NP6AK			PCTFE			0.51	0.55	0.65	0.52				
4F-NP6LR	4F-NP6AR	1/4" Female NPT		Blunt	0.177	4.5	0.60	0.50	0.67	0.39	1.00	25.4	1.00	25.4
4F-NP6LK	4F-NP6AK			PCTFE			0.51	0.55	0.65	0.52				
4M-NP6LR	4M-NP6AR	1/4" Male NPT		Blunt	0.177	4.5	0.60	0.50	0.67	0.39	1.03	26.2	1.03	26.2
4M-NP6LK	4M-NP6AK			PCTFE			0.51	0.55	0.65	0.52				
4Z-NP6LR	4Z-NP6AR	1/4" Compression CPI™		Blunt	0.177	4.5	0.60	0.50	0.67	0.39	1.20	30.5	1.20	30.5
4Z-NP6LK	4Z-NP6AK			PCTFE			0.51	0.55	0.65	0.52				
6A-NP6LR	6A-NP6AR	3/8" Compression A-LOK®		Blunt	0.177	4.5	0.60	0.50	0.67	0.39	1.23	31.2	1.23	31.2
6A-NP6LK	6A-NP6AK			PCTFE			0.51	0.55	0.65	0.52				
6Z-NP6LR	6Z-NP6AR	3/8" Compression CPI™		Blunt	0.177	4.5	0.60	0.50	0.67	0.39	1.23	31.2	1.23	31.2
6Z-NP6LK	6Z-NP6AK			PCTFE			0.51	0.55	0.65	0.52				
M6A-NP6LR	M6A-NP6AR	6mm Compression A-LOK®		Blunt	0.177	4.5	0.60	0.50	0.67	0.39	1.16	29.5	1.16	29.5
M6A-NP6LK	M6A-NP6AK			PCTFE			0.51	0.55	0.65	0.52				
M6Z-NP6LR	M6Z-NP6AR	6mm Compression CPI™		Blunt	0.177	4.5	0.60	0.50	0.67	0.39	1.16	29.5	1.16	29.5
M6Z-NP6LK	M6Z-NP6AK			PCTFE			0.51	0.55	0.65	0.52				
M8A-NP6LR	M8A-NP6AR	8mm Compression A-LOK®		Blunt	0.177	4.5	0.60	0.50	0.67	0.39	1.24	31.5	1.24	31.5
M8A-NP6LK	M8A-NP6AK			PCTFE			0.51	0.55	0.65	0.52				
M8Z-NP6LR	M8Z-NP6AR	8mm Compression CPI™		Blunt	0.177	4.5	0.60	0.50	0.67	0.39	1.24	31.5	1.24	31.5
M8Z-NP6LK	M8Z-NP6AK			PCTFE			0.51	0.55	0.65	0.52				

\* Tested in accordance with ISA S75.02. Gas flow will be choked when  $P_1 - P_2 / P_1 = X_T$ .  
 † For CPI™ and A-LOK®, dimensions are measured with nuts in the finger tight position.

Dimensions in inches/millimeters are for reference only, subject to change.

## Pressure vs. Temperature

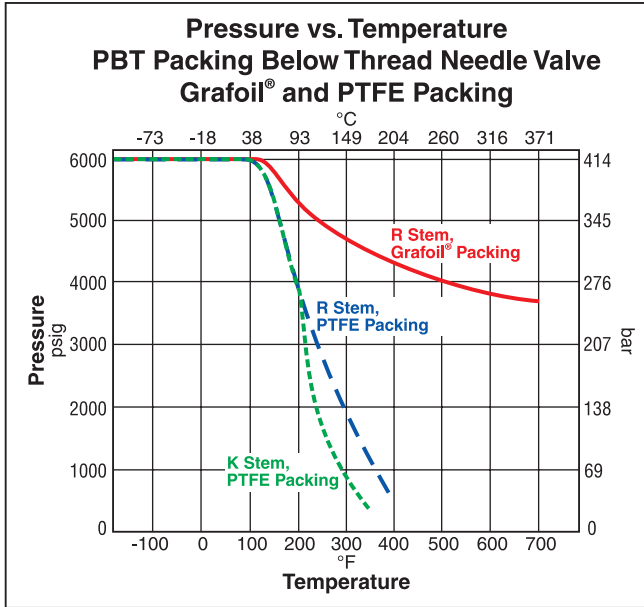

Note: To determine MPa, multiply bar by 0.1

## Flow Characteristics

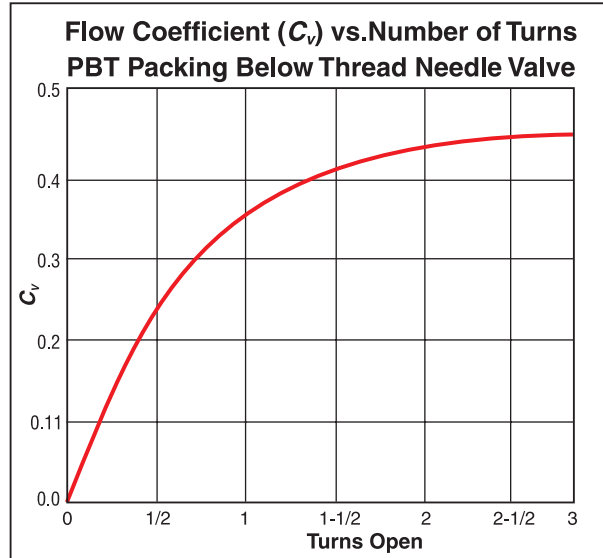

Note: When combining seat and seal materials, the most restrictive temperature rating becomes the limiting factor on temperature range.

NP6

## How to Order

Dimensions in inches/millimeters are for reference only, subject to change.

The correct part number is easily derived from the following example and ordering chart. The six product characteristics required are coded as shown in the chart.

Example 1, below, describes an angle pattern NP6 Series needle valve equipped with 1/4" CPI™ compression inlet and outlet ports, a PCTFE tipped stem, Nitrile seals, and stainless steel construction with panel mounting nut.

Example 2, below, describes an inline pattern NP6 Series needle valve equipped with 1/4" male NPT inlet port, 1/4" female NPT outlet port, a blunt stem type, PTFE stem seal, stainless steel construction with panel mounting nut.

**Example 1: 4Z-NP6AK-BN-SSP** (shown in the part number blocks below)

**Example 2: 4M4F-NP6LR-SSP**

4Z		NP6A		K	BN		SSP	
Inlet Port*	Outlet Port*	Valve Series	Stem Type		Stem Seal	Body Material		
4A	6A	NP6L	R Blunt		Blank	SSP Stainless Steel with Panel Nut		
4F	6Z	NP6A	K PCTFE		BN Nitrile Rubber			
4M					EPR Ethylene Propylene Rubber			
4Z	M8Z				V Fluorocarbon Rubber			
					G Grafoil®			

\*If the inlet and outlet ports are the same, eliminate the outlet port designator.

## How to Order Options

**Colored Nylon Handles** – Add the designator corresponding to the correct handle color as a suffix to the part number. Black is standard, **W** - white, **B** - blue, **G** - green, **R** - red, **Y** - yellow. **Example:** 4A-NP6LK-SS-**G**

**Oxygen Cleaning** – Add the suffix **-C3** to the end of the part number to receive valves cleaned and assembled for oxygen service in accordance with Parker Specification ES8003. **Example:** M6A-NP6AK-EPR-SS-**C3**

Grafoil® is a registered trademark of GrafTech International Holdings, Inc.

NP6

## Introduction

Parker compact SN6 Needle Valves provide shut-off and coarse regulation of liquids and gases utilized in process and instrumentation applications. These rugged valves are manufactured from stainless steel barstock and are integral bonnet designs with packing above the stem threads.

## Features

- ▶ Integral bonnet design
- ▶ 316 stainless steel construction
- ▶ Choice of two stem types:
  - R-Stem – All metal, blunt stem tip
  - K-Stem – PCTFE stem tip
- ▶ Choice of PTFE or Grafoil® packing
- ▶ Inline and angle patterns
- ▶ 100% factory tested

## Materials of Construction

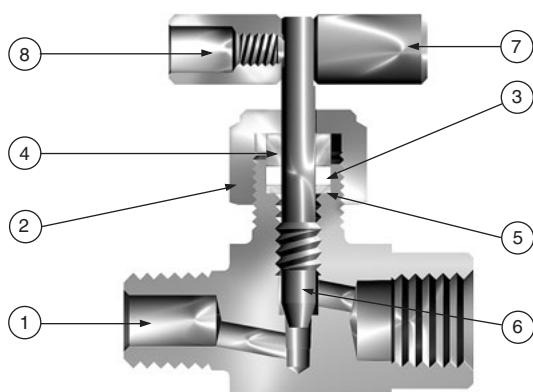

**Model Shown:**  
**4F4M-SN6LR-SS**

Item #	Description	Material
1	Body	ASTM A 182 Type 316
2	Packing Nut	ASTM A 479 Type 316
3	Packing*	PTFE
4	Packing Gland	ASTM A 276 Type 316
5	Packing Washer	Stainless Steel
6	Stem (R-Stem)	ASTM A 276 Type 316
7	Stem (K-Stem)	ASTM A 276 Type 316, with PCTFE
8	Handle**	Aluminum
9	Handle Screw	Stainless Steel

\* Optional Grafoil® packing available - [See How to Order](#).

\*\* Handles for Grafoil® packed valves and valves with R stem types are stainless steel T-bars.  
Lubrication: Perfluorinated polyether.

Grafoil® is a registered trademark of GrafTech International Holdings, Inc.

## Specifications

### Pressure Rating:

R Stem: 6000 psig (414 bar) CWP

K Stem: 3000 psig (207 bar) CWP

### Temperature Rating:

PTFE Packing:

-65°F to 450°F (-54°C to 232°C)

PCTFE Stem Tip:

-65°F to 350°F (-54°C to 177°C)

Grafoil® (G) Packing:

-65°F to 700°F (-54°C to 371°C)

## Pressure Rating and Tubing Selection

For working pressures of A-LOK® and CPI™ tube connections, please see the Instrument Tubing Selection Guide (Bulletin 4200-TS), found in the Technical Section of the Parker Instrumentation Process Control Binder, or the Parker Instrument Tube Fitting Installation Manual (Bulletin 4200-B4).

For working pressures of valves with external or internal pipe threads, please see Catalog 4260, Instrumentation Pipe Fittings.

## Dimensions / Flow Data

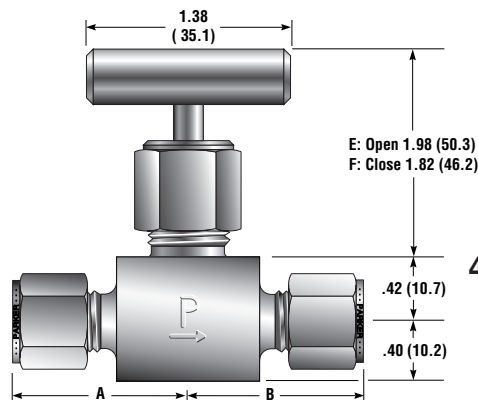

Body width = .80 (20.3)  
( ) Denotes dimensions in millimeters

Model Shown:  
4M-SN6AK-SS

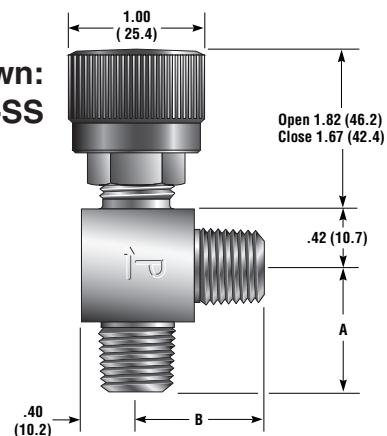

Model Shown:  
4Z-SN6LR-G-SS

Basic Part Number		End Connections		Stem Type	Flow Data				Dimensions					
Inline	Angle	Inlet (Port 1)	Outlet (Port 2)		Orifice		Inline		Angle		A†		B†	
					Inch	mm	$C_V$	$X_T^*$	$C_V$	$X_T^*$	Inch	mm	Inch	mm
4A-SN6LR	4A-SN6AR	1/4" Compression A-LOK®		Blunt	0.125	3.2	0.29	0.56	0.34	0.55	1.17	29.7	1.17	29.7
4A-SN6LK	4A-SN6AK			PCTFE			0.23	0.63	0.27	0.58				
4F-SN6LR	4F-SN6AR	1/4" Female NPT		Blunt	0.125	3.2	0.29	0.56	0.34	0.55	0.94	23.9	0.94	23.9
4F-SN6LK	4F-SN6AK			PCTFE			0.23	0.63	0.27	0.58				
4M-SN6LR	4M-SN6AR	1/4" Male NPT		Blunt	0.125	3.2	0.29	0.56	0.34	0.55	0.99	25.1	0.99	25.1
4M-SN6LK	4M-SN6AK			PCTFE			0.23	0.63	0.27	0.58				
4Z-SN6LR	4Z-SN6AR	1/4" Compression CPI™		Blunt	0.125	3.2	0.29	0.56	0.34	0.55	1.17	29.7	1.17	29.7
4Z-SN6LK	4Z-SN6AK			PCTFE			0.23	0.63	0.27	0.58				
4M4A-SN6LR	4M4A-SN6AR	1/4" Male NPT	1/4" A-LOK®	Blunt	0.125	3.2	0.29	0.56	0.34	0.55	0.99	25.1	1.17	29.7
4M4A-SN6LK	4M4A-SN6AK			PCTFE			0.23	0.63	0.27	0.58				
4M4F-SN6LR	4M4F-SN6AR	1/4" Male NPT	1/4" Female NPT	Blunt	0.125	3.2	0.29	0.56	0.34	0.55	0.99	25.1	0.94	23.9
4M4F-SN6LK	4M4F-SN6AK			PCTFE			0.23	0.63	0.27	0.58				
4M4Z-SN6LR	4M4Z-SN6AR	1/4" Male NPT	1/4" CPI™	Blunt	0.125	3.2	0.29	0.56	0.34	0.55	0.99	25.1	1.17	29.7
4M4Z-SN6LK	4M4Z-SN6AK			PCTFE			0.23	0.63	0.27	0.58				

\* Tested in accordance with ISA S75.02. Gas flow will be choked when  $P_1 - P_2 / P_1 = X_T$ .  
† For CPI™ and A-LOK®, dimensions are measured with nuts in the finger tight position.

Dimensions in inches/millimeters are for reference only, subject to change.

SN6

## Pressure vs. Temperature

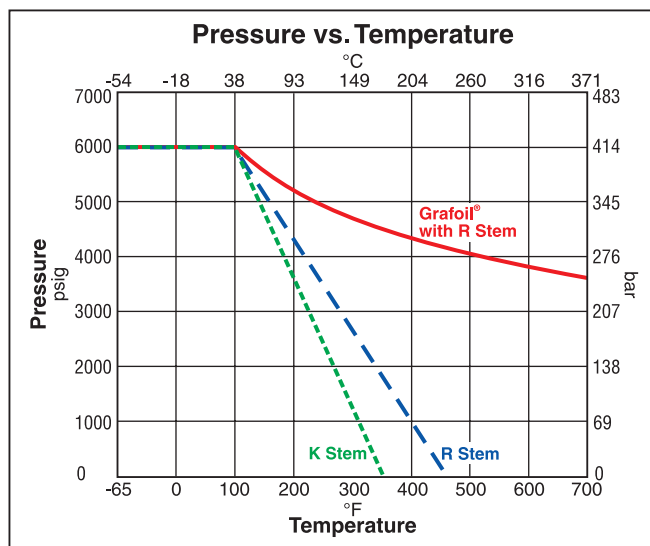

### Notes:

To determine MPa, multiply bar by 0.1

When combining seat and seal materials, the most restrictive temperature rating becomes the limiting factor on temperature range.

SN6

## How to Order

Dimensions in inches/millimeters are for reference only, subject to change.

The correct part number is easily derived from the following example and ordering chart. The six product characteristics required are coded as shown in the chart.

Example 1, below, describes an SN6 valve, inline, blunt stem, 316 SS, 1/4" CPI™ tube inlet and outlet ports, and a PTFE packing.

Example 2, below, describes an SN6 valve, angle, PCTFE stem tip, 316 SS, 1/4" male pipe inlet port, 1/4" female pipe outlet port, and a PTFE packing.

**Example 1: 4Z-SN6LR-SS** (shown in the part number blocks below)

**Example 2: 4M4F-SN6AK-SS**

	4Z		-	SN6L R		-		-	SS
	Inlet Port*	Outlet Port*		Valve Series	Stem Type		Packing		Body Material
Size	Inlet Port	Outlet Port		Valve Series	Stem Type		Packing		Body Material
4	A A-LOK® (tube) Z CPI™ (tube) M Male pipe (NPT) F Female pipe (NPT)			SN6L SN6A	R Blunt (20°) K PCTFE		Blank PTFE G Grafoil®		SS 316 Stainless Steel

\*If the inlet and outlet ports are the same, eliminate the outlet port designator.

**Note: Handles:** SN6 valves with R-Stem are standard with 316 SS T-bar handles. SN6 valves with K-Stem are standard with round anodized aluminum handles, 1.00 inch diameter. SN6 valves are not panel mountable.

Grafoil® is a registered trademark of GrafTech International Holdings, Inc.





## Introduction

Parker Rising Plug and Gauge/Root Valves are available with a variety of seat and seal materials. They are screwed bonnet designs featuring bonnet lock plates. The PV and PVG Series of valves provide a straight-through flow path in two orifice sizes. The valves utilize a non-wetted upper stem and a non-rotating lower stem in conjunction with a tapered seat for positive shut-off and long seat life, even in particulated media.

## Features

- ▶ Bi-directional flow
- ▶ Roddable, straight through flow path
- ▶ Bonnet lock plate resists accidental bonnet disengagement
- ▶ Stem dust seal helps protect stem from external contamination
- ▶ Inlet side optional outlet – PVG 1/4" Female NPT – PVG 1/2" Female NPT
- ▶ Rugged 316 stainless steel barstock construction
- ▶ Panel mounting option
- ▶ Gauge port option
- ▶ 100% factory tested

## Specifications

### Pressure Rating:

Acetal Seat (DE): 6000 psig (414 bar) CWP  
 PEEK Seat (PK): 6000 psig (414 bar) CWP  
 PCTFE Seat (K): 2200 psig (152 bar) CWP  
 PFA Seat (PFA): 750 psig (52 bar) CWP

### Temperature Rating:

#### Seats –

Acetal:  
 -20°F to 250°F (-29°C to 121°C)  
 PEEK and PFA:  
 -20°F to 400°F (-29°C to 204°C)  
 PCTFE:  
 -20°F to 200°F (-29°C to 93°C)

#### Stem Seals –

Nitrile Rubber (BN), Silicone Rubber (SI), and Ethylene Propylene Rubber (EPR):  
 -20°F to 250°F (-29°C to 121°C)  
 Fluorocarbon Rubber (V):  
 -20°F to 400°F (-29°C to 204°C)  
 Highly Fluorinated Fluorocarbon Rubber (KZ):  
 -20°F to 200°F (-29°C to 93°C)

## Flow Data

PV4:  $C_V = 0.95$ ;  $x_T = 0.43$ ; Orifice = 0.188" (4.8mm)  
 PV8:  $C_V = 2.01$ ;  $x_T = 0.33$ ; Orifice = 0.250" (6.4mm)

Tested in accordance with ISA S75.02. Gas flow will be choked when  $P_1 - P_2 / P_1 = x_T$ .

## Materials of Construction

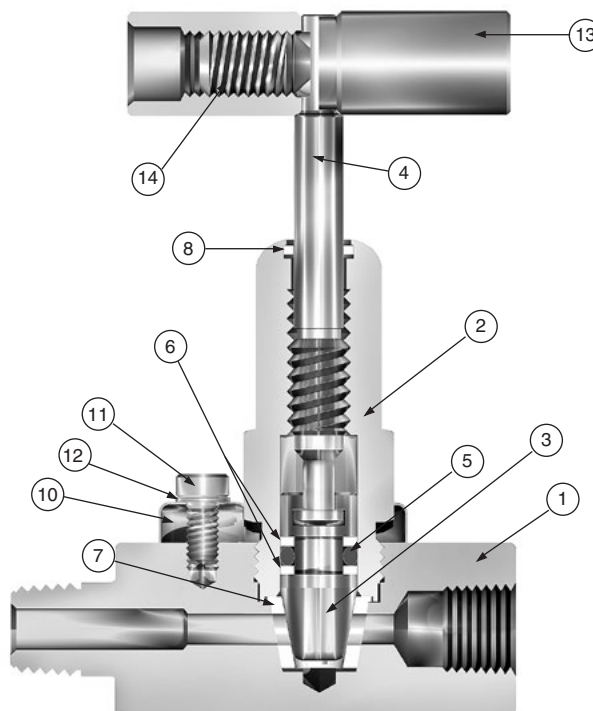

**Model Shown:  
4M4F-PV4DE-BN-SS**

Item #	Description	Material
1	Body	ASTM A 479 Type 316
2	Bonnet	ASTM A 479 Type 316
3	Lower Stem	ASTM A 276 Type 316
4	Upper Stem	ASTM A 564 Type 316
5	Stem Seal*	Fluorocarbon Rubber
6	Back-up Rings	PTFE
7	Seat*	Acetal
8	Dust Seal	PTFE
9	Seat Pin (not shown)	Stainless Steel
10	Lock Plate	Stainless Steel
11	Lock Plate Screw	Stainless Steel
12	Lock Washer	Stainless Steel
13	Handle	Stainless Steel
14	Handle Screw	Stainless Steel

\* Optional elastomeric O-ring stem seals and polymer seat materials are available - [See How to Order](#).  
 Lubrication: Perfluorinated polyether

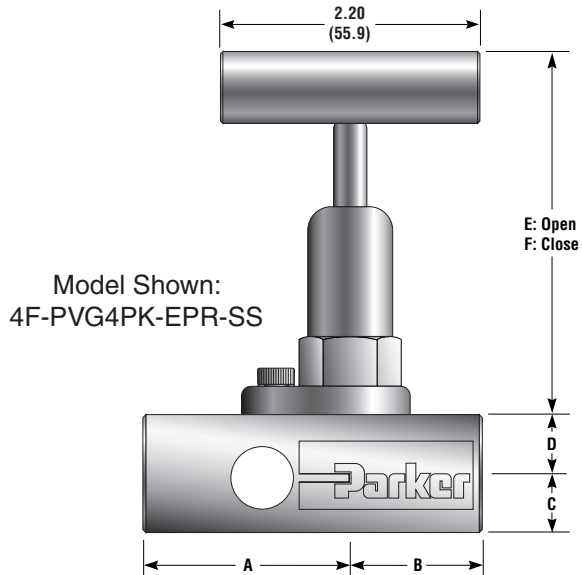
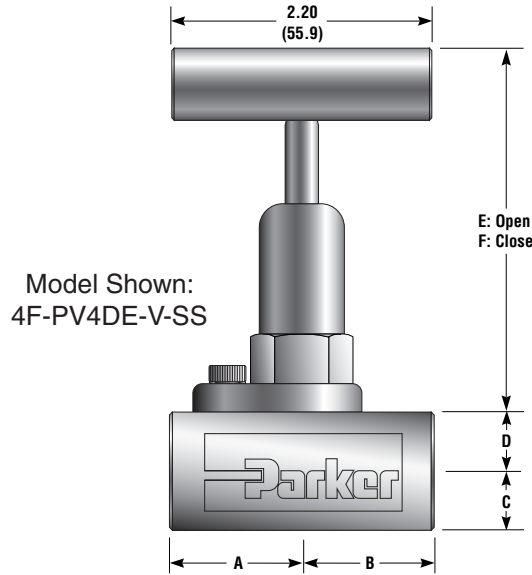

## Dimensions

( ) Denotes dimensions in millimeters

Basic Part Number	End Connection		Dimensions											
	Inlet (Port 1)	Outlet (Port 2)	A†		B†		C		D		E		F	
			Inch	mm	Inch	mm	Inch	mm	Inch	mm	Inch	mm	Inch	mm
4A-PV4	1/4" Compression A-LOK®	1/4" Compression A-LOK®	1.73	43.9	1.73	43.9	0.50	12.7	0.50	12.7	3.04	77.2	2.93	74.4
4F-PV4	1/4" Female NPT	1/4" Female NPT	1.13	28.7	1.13	28.7	0.50	12.7	0.50	12.7	3.04	77.2	2.93	74.4
4F-PVG4	1/4" Female NPT	1/4" Female NPT	1.75	44.5	1.13	28.7	0.50	12.7	0.50	12.7	3.04	77.2	2.93	74.4
4M4F-PV4	1/4" Male NPT	1/4" Female NPT	1.78	45.2	1.13	28.7	0.50	12.7	0.50	12.7	3.04	77.2	2.93	74.4
4Z-PV4	1/4" Compression CPI™	1/4" Compression CPI™	1.73	43.9	1.73	43.9	0.50	12.7	0.50	12.7	3.04	77.2	2.93	74.4
6A-PV4	3/8" Compression A-LOK®	3/8" Compression A-LOK®	1.79	45.5	1.79	45.5	0.50	12.7	0.50	12.7	3.04	77.2	2.93	74.4
6Z-PV4	3/8" Compression CPI™	3/8" Compression CPI™	1.79	45.5	1.79	45.5	0.50	12.7	0.50	12.7	3.04	77.2	2.93	74.4
8M4F-PV4	1/2" Male NPT	1/4" Female NPT	1.90	48.3	1.13	28.7	0.50	12.7	0.50	12.7	3.04	77.2	2.93	74.4
8M4F-PVG4	1/2" Male NPT	1/4" Female NPT	3.13	79.5	1.75	44.5	0.50	12.7	0.50	12.7	3.04	77.2	2.93	74.4
6M6F-PVG8	3/8" Male NPT	3/8" Female NPT	3.33	84.6	2.25	57.2	0.56	14.2	0.56	14.2	3.04	77.2	2.93	74.4
8A-PV8	1/2" Compression A-LOK®	1/2" Compression A-LOK®	1.91	48.5	1.91	48.5	0.56	14.2	0.56	14.2	3.04	77.2	2.93	74.4
8F-PV8	1/2" Female NPT	1/2" Female NPT	1.33	33.8	1.33	33.8	0.56	14.2	0.56	14.2	3.04	77.2	2.93	74.4
8M8F-PV8	1/2" Male NPT	1/2" Female NPT	2.17	55.1	1.33	33.8	0.56	14.2	0.56	14.2	3.04	77.2	2.93	74.4
8M8F-PVG8	1/2" Male NPT	1/2" Female NPT	3.33	84.6	2.25	57.2	0.56	14.2	0.56	14.2	3.04	77.2	2.93	74.4
8Z-PV8	1/2" Compression CPI™	1/2" Compression CPI™	1.91	48.5	1.91	48.5	0.56	14.2	0.56	14.2	3.04	77.2	2.93	74.4
12M8F-PV8	3/4" Male NPT	1/2" Female NPT	2.17	55.1	1.33	25.4	0.56	14.2	0.56	14.2	3.04	77.2	2.93	74.4

† For CPI™ and A-LOK®, dimensions are measured with nuts in the finger tight position.

Dimensions in inches/millimeters are for reference only, subject to change.

PV

## Pressure vs. Temperature

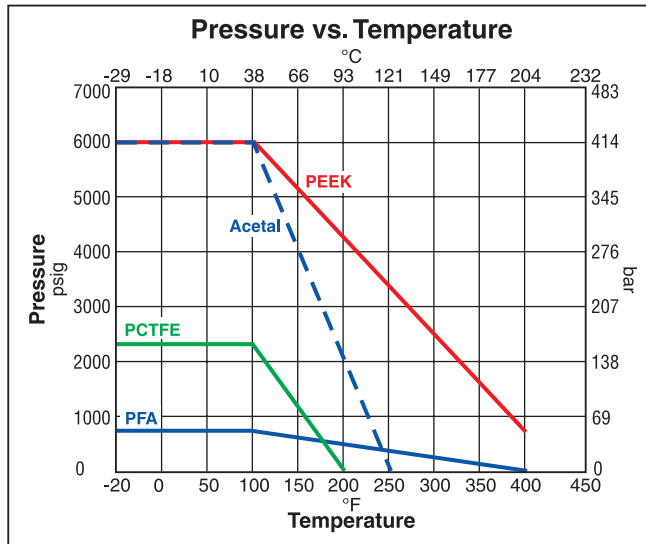

## Flow Characteristics

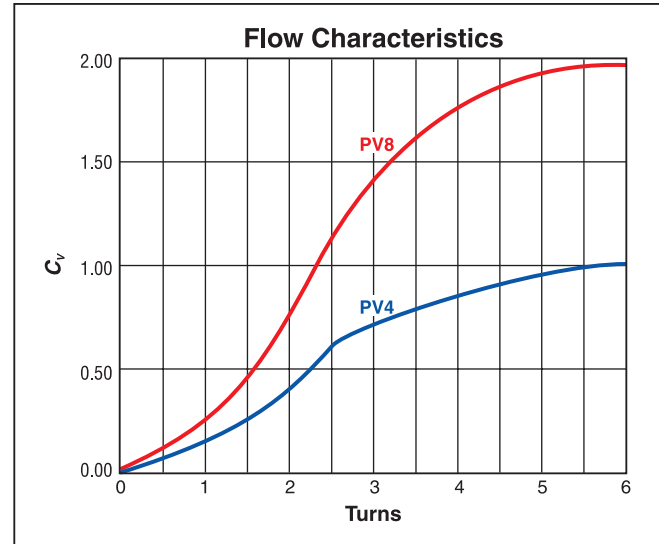

## How to Order

Dimensions in inches/millimeters are for reference only, subject to change.

PV

The correct part number is easily derived from the following example and ordering chart. The six product characteristics required are coded as shown in the chart.

Example 1, below, describes a PV4 Series rising stem plug valve equipped with 1/4" CPI™ compression inlet and outlet ports, a PCTFE seat, Nitrile stem seals, and stainless steel construction.

Example 2, below, describes a PVG4 Series rising stem plug valve with 1/4" gauge ports equipped with a 1/4" Male NPT inlet port and 1/4" Female NPT outlet port, an acetal seat, fluorocarbon stem seals, and stainless steel construction with panel mounting option.

**Example 1: 4Z-PV4K-BN-SS** (shown in the part number blocks below)

**Example 2: 4M-PVG4DE-V-SSP**

4Z		PV4		K		BN		SS	
Inlet Port*		Valve Series		Seat Type		Stem Seal Material		Body Material	
4A	4M	PV4	DE	Acetal	V	Fluorocarbon	SS	Stainless Steel	
4F	4Z	PVG4	K	PCTFE		Rubber	SSP	Stainless Steel	
6M	8A	PV8	PK	PEEK	BN	Nitrile Rubber		with Panel	
6F	8F	PVG8	PFA	PFA	SI	Silicone Rubber		Mounting Option	
					EPR	Ethylene Propylene Rubber			
					KZ	Highly Fluorinated Fluorocarbon Rubber			

\*If the inlet and outlet ports are the same, eliminate the outlet port designator.



## Medium Pressure Valves

### MPN Series Valves

Parker MPN series valves are designed for multi-turn control of media regulation and shutoff up to 20,000 psi. Additional packing materials are available for application temperatures from -300° to +800° F. Standard critical service design features, such as the packing below the thread and the non-rotating lower stem ensure longer valve life in rugged applications.

### Medium Pressure Valve Connection Types

**F**  
Female NPT  
To 15,000 PSI

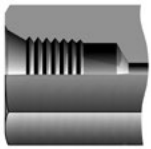

**MP7**  
Parker MPI™  
(Medium Pressure  
Inverted)  
To 15,000 PSI

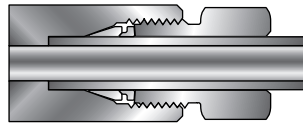

**MF**  
Cone & Thread  
(Medium Pressure  
Female)  
To 20,000 PSI

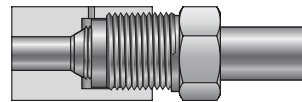

### Materials of Construction

Item #	Description	Material
1	Soc Set Screw	Steel
2	Handle	Aluminum
3	Upper Stem Assembly	17-4PH
4	Packing Gland	316SS
5	Locking Device	300 SER. SS
6	10-32 X 1/4 Fill HD SCR.	300 SER. SS
7	Stem Pin	304SS
8	Top Packing Washer	416SS
9	Packing	PTFE
10	Bottom Packing Washer	316SS
11	Lower Stem	17-4PH-H900
12	Body	316SS

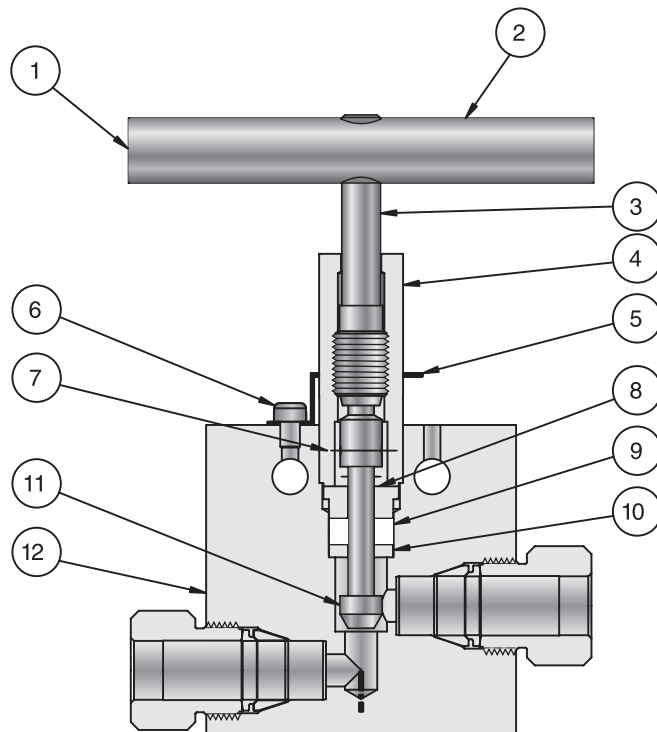

MPN

## How to Order MPN Series Valves

Dimensions in inches/millimeters are for reference only, subject to change.

The correct part number is easily derived from the following example and ordering chart. The nine product characteristics required are coded as shown in the chart.

The following example describes an MPN Series needle valve with 1/4" MPI connections, 2 way angle flow path, blunt stem, PTFE packing, stainless steel body and the option for over critical service.

### Example: 4MP7-MPNAB-T-SS-OC

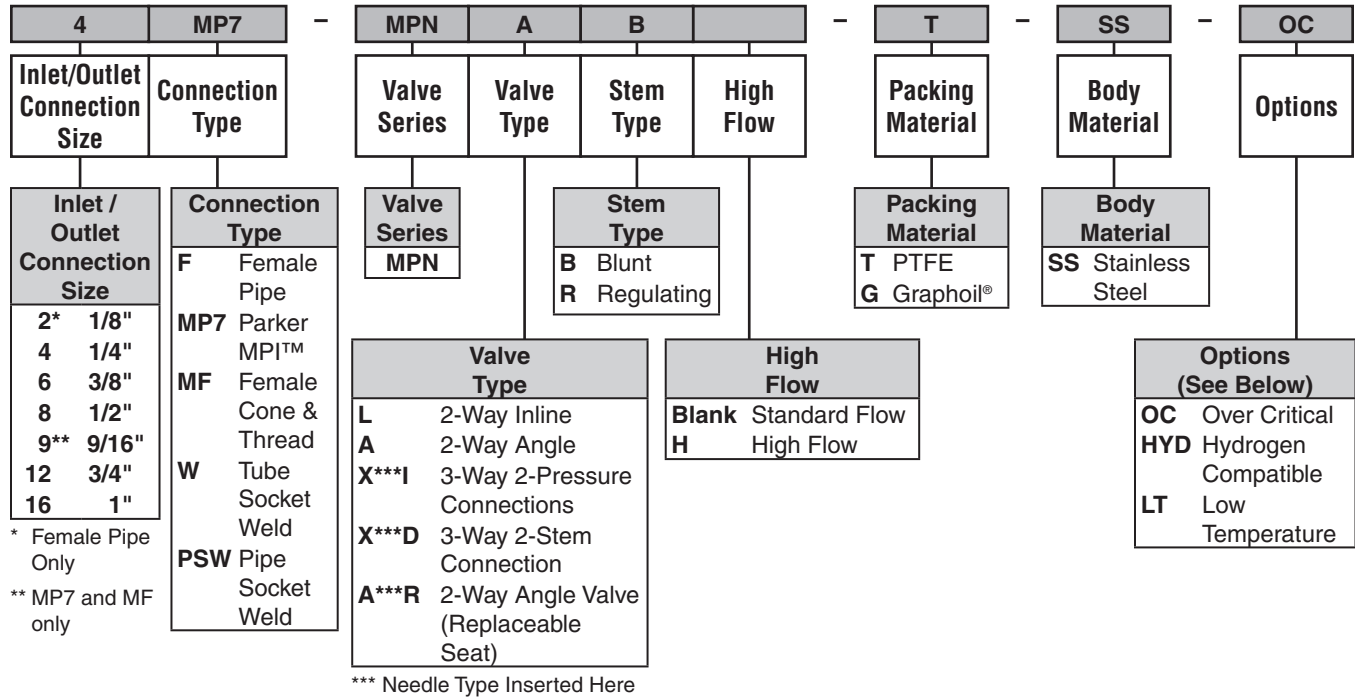

## How to Order Options

**Over Critical** – add the suffix **-OC** to the end of the part number to specify over critical service.

**Hydrogen Service** – add the suffix **-HYD** to the end of the part number for a valve suitable for hydrogen service.

**Low Temperature** – add the suffix **-LT** to the end of the part number for low temperature service.

Grafoil® is a registered trademark of GrafTech International Holdings, Inc.

## Two Way Inline Valves

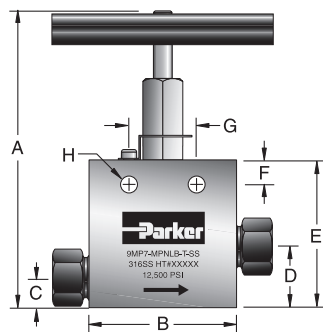

Panel Hole Sizes  
Medium Pressure Needle Valve Panel Mount

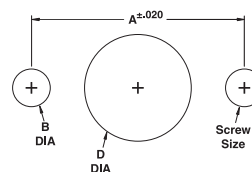

Valve Size	A	B	Screw Size	D
4 & 6	1.25	.219	10 - 32	.75
8 & 9	1.375	.219	10 - 32	1.00
12	1.75	.219	10 - 32	1.19
16	2.50	.219	10 - 32	1.63

Tubing Size	Parker Part No.	PSI	Connection	Inches									
				Orifice	A	B	C	D	E	F	G	H	Th'k
1/4" O.D.	4MP7-MPNLB-T-SS	15,000	1/4" MPI	0.125	4.50	2.50	0.50	0.94	2.13	0.38	1.25	0.22	1.00
3/8" O.D.	6MP7-MPNLB-T-SS	15,000	3/8" MPI	0.203	4.50	2.50	0.50	0.94	2.13	0.38	1.25	0.22	1.00
1/2" O.D.	8MP7-MPNLB-T-SS	15,000	1/2" MPI	0.313	6.26	3.00	0.63	1.25	3.00	0.50	1.38	0.34	1.38
9/16" O.D.	9MP7-MPNLB-T-SS	15,000	9/16" MPI	0.313	6.26	3.00	0.63	1.25	3.00	0.50	1.38	0.34	1.38
3/4" O.D.	12MP7-MPNLB-T-SS	15,000	3/4" MPI	0.438	7.00	4.13	0.75	1.50	3.75	0.63	1.75	0.44	1.75
3/4" O.D.	12MP7-MPNLBH-T-SS	10,000	3/4" MPI	0.516	7.00	4.13	0.75	1.50	3.75	0.63	1.75	0.44	1.75
1" O.D.	16MP7-MPNLB-T-SS	12,500	1" MPI	0.563	8.42	4.13	0.88	1.81	4.63	1.13	2.50	0.56	1.75

Pipe Size	Parker Part No.	PSI	Connection Female NPT	Inches									
				Orifice	A	B	C	D	E	F	G	H	Th'k
1/8" NPT	2F-MPNLB-T-SS	15,000	1/8"	0.203	4.38	2.00	0.38	0.81	2.00	0.38	1.25	0.22	0.75
1/4" NPT	4F-MPNLB-T-SS	15,000	1/4"	0.203	4.38	2.00	0.38	0.81	2.00	0.38	1.25	0.22	0.75
3/8" NPT	6F-MPNLB-T-SS	15,000	3/8"	0.312	6.13	2.50	0.50	1.13	2.88	0.50	1.38	0.34	1.00
1/2" NPT	8F-MPNLB-T-SS	15,000	1/2"	0.312	6.38	2.63	0.75	1.38	3.13	0.50	1.38	0.34	1.50
3/4" NPT	12F-MPNLB-T-SS	10,000	3/4"	0.687	8.50	4.13	0.88	1.81	4.63	1.13	2.50	0.56	1.75
1" NPT	16F-MPNLB-T-SS	10,000	1"	0.687	8.50	4.13	0.88	1.81	4.63	1.13	2.50	0.56	1.75

Dimensions in inches/millimeters are for reference only, subject to change.

MPN



## Two Way Angle Valves

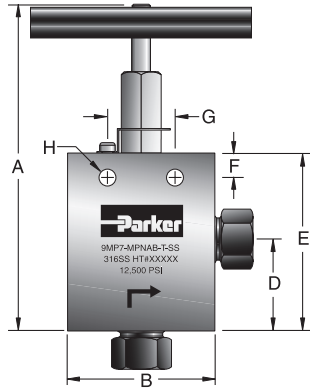

Panel Hole Sizes  
Medium Pressure Needle Valve Panel Mount

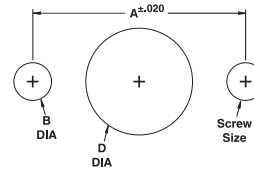

Valve Size	A	B	Screw Size	D
4 & 6	1.25	.219	10 - 32	.75
8 & 9	1.375	.219	10 - 32	1.00
12	1.75	.219	10 - 32	1.19
16	2.50	.219	10 - 32	1.63

Tubing	Parker Part No.	PSI	Connection	Inches									
				Orifice	A	B	C	D	E	F	G	H	Th'k
1/4" O.D.	4MP7-MPNAB-T-SS	15,000	1/4" MPI	0.125	5.02	2.50	-	1.38	2.57	0.38	1.25	0.22	1.00
3/8" O.D.	6MP7-MPNAB-T-SS	15,000	3/8" MPI	0.203	5.02	2.50	-	1.38	2.57	0.38	1.25	0.22	1.00
1/2" O.D.	8MP7-MPNAB-T-SS	15,000	1/2" MPI	0.313	6.84	3.00	-	1.83	3.58	0.50	1.38	0.34	1.38
9/16" O.D.	9MP7-MPNAB-T-SS	15,000	9/16" MPI	0.313	6.84	3.00	-	1.83	3.58	0.50	1.38	0.34	1.38
3/4" O.D.	12MP7-MPNAB-T-SS	15,000	3/4" MPI	0.438	7.50	3.00	-	2.00	4.25	0.63	1.75	0.44	1.38
3/4" O.D.	12MP7-MPNABH-T-SS	10,000	3/4" MPI	0.516	7.50	3.00	-	2.00	4.25	0.63	1.75	0.44	1.38
1" O.D.	16MP7-MPNAB-T-SS	12,500	1" MPI	0.563	9.38	4.13	-	2.56	5.44	1.13	2.50	0.56	1.75
1" O.D.	16MP7-MPNABH-T-SS	10,000	1" MPI	0.688	9.38	4.13	-	2.56	5.44	1.13	2.50	0.56	1.75

Pipe Size	Parker Part No.	PSI	Connection Female NPT	Inches									
				Orifice	A	B	C	D	E	F	G	H	Th'k
1/8" NPT	2F-MPNAB-T-SS	15,000	1/8" NPTF	0.203	4.81	2.00	-	1.25	2.44	0.38	1.25	0.22	0.75
1/4" NPT	4F-MPNAB-T-SS	15,000	1/4" NPTF	0.203	4.81	2.00	-	1.25	2.44	0.38	1.25	0.22	0.75
3/8" NPT	6F-MPNAB-T-SS	15,000	3/8" NPTF	0.312	6.50	2.50	-	1.50	3.25	0.50	1.38	0.34	1.00
1/2" NPT	8F-MPNAB-T-SS	15,000	1/2" NPTF	0.312	6.50	2.63	-	1.50	3.25	0.50	1.38	0.34	1.50
3/4" NPT	12F-MPNAB-T-SS	10,000	3/4" NPTF	0.687	9.00	4.13	-	2.31	5.13	1.13	2.50	0.56	1.75
1" NPT	16F-MPNAB-T-SS	10,000	1" NPTF	0.687	9.00	4.13	-	2.31	5.13	1.13	2.50	0.56	1.75

Dimensions in inches/millimeters are for reference only, subject to change.

MPN

## Three Way/Two Pressure Connections

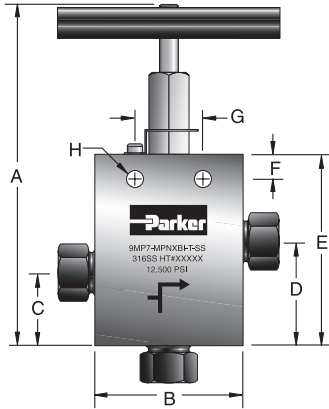

Panel Hole Sizes  
Medium Pressure Needle Valve Panel Mount

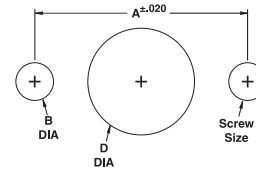

Valve Size	A	B	Screw Size	D
4 & 6	1.25	.219	10 - 32	.75
8 & 9	1.375	.219	10 - 32	1.00
12	1.75	.219	10 - 32	1.19
16	2.50	.219	10 - 32	1.63

Tubing	Parker Part No.	PSI	Connection	Inches									
				Orifice	A	B	C	D	E	F	G	H	Th'k
1/4" O.D.	4MP7-MPNXBI-T-SS	15,000	1/4" MPI	0.125	5.21	2.50	1.21	1.65	2.84	0.38	1.25	0.22	1.00
3/8" O.D.	6MP7-MPNXBI-T-SS	15,000	3/8" MPI	0.203	5.21	2.50	1.21	1.65	2.84	0.38	1.25	0.22	1.00
1/2" O.D.	8MP7-MPNXBI-T-SS	12,500	1/2" MPI	0.313	7.09	3.00	1.50	2.12	3.88	0.50	1.38	0.34	1.38
9/16" O.D.	9MP7-MPNXBI-T-SS	12,500	9/16" MPI	0.313	7.09	3.00	1.50	2.12	3.88	0.50	1.38	0.34	1.38
3/4" O.D.	12MP7-MPNXBI-T-SS	15,000	3/4" MPI	0.438	7.88	3.00	2.63	2.38	4.63	0.63	1.75	0.44	1.38
3/4" O.D.	12MP7-MPNXBIH-T-SS	10,000	3/4" MPI	0.516	7.88	3.00	2.63	2.38	4.63	0.63	1.75	0.44	1.38
1" O.D.	16MP7-MPNXBI-T-SS	12,500	1" MPI	0.563	9.75	4.13	2.13	3.06	5.88	1.13	2.50	0.56	1.75
1" O.D.	16MP7-MPNXBIH-T-SS	10,000	1" MPI	0.688	9.75	4.13	2.13	3.06	5.88	1.13	2.50	0.56	1.75

Dimensions in inches/millimeters are for reference only, subject to change.

MPN

## Three Way/One Pressure Connection

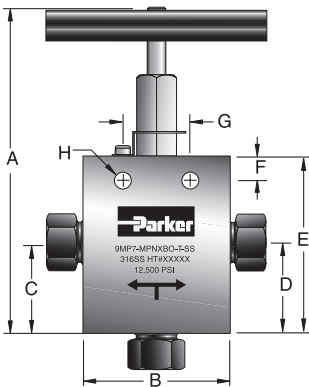

Panel Hole Sizes  
Medium Pressure Needle Valve Panel Mount

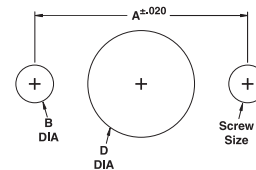

Valve Size	A	B	Screw Size	D
4 & 6	1.25	.219	10 - 32	.75
8 & 9	1.375	.219	10 - 32	1.00
12	1.75	.219	10 - 32	1.19
16	2.50	.219	10 - 32	1.63

Tubing	Parker Part No.	PSI	Connection	Inches									
				Orifice	A	B	C	D	E	F	G	H	Th'k
1/4" O.D.	4MP7-MPNXBO-T-SS	15,000	1/4" MPI	0.125	5.02	2.50	1.38	1.38	2.57	0.38	1.25	0.22	1.00
3/8" O.D.	6MP7-MPNXBO-T-SS	15,000	3/8" MPI	0.203	5.02	2.50	1.38	1.38	2.57	0.38	1.25	0.22	1.00
1/2" O.D.	8MP7-MPNXBO-T-SS	15,000	1/2" MPI	0.313	6.84	3.00	1.88	1.88	3.63	0.50	1.38	0.34	1.38
9/16" O.D.	9MP7-MPNXBO-T-SS	15,000	9/16" MPI	0.313	6.84	3.00	1.88	1.88	3.63	0.50	1.38	0.34	1.38
3/4" O.D.	12MP7-MPNXBO-T-SS	15,000	3/4" MPI	0.438	7.50	3.00	2.00	2.00	4.25	0.63	1.75	0.44	1.38
3/4" O.D.	12MP7-MPNXBOH-T-SS	10,000	3/4" MPI	0.516	7.50	3.00	2.00	2.00	4.25	0.63	1.75	0.44	1.38
1" O.D.	16MP7-MPNXBO-T-SS	12,500	1" MPI	0.563	9.38	4.13	2.63	2.63	5.44	1.13	2.50	0.56	1.75
1" O.D.	16MP7-MPNXBOH-T-SS	10,000	1" MPI	0.688	9.38	4.13	2.63	2.63	5.44	1.13	2.50	0.56	1.75

Dimensions in inches/millimeters are for reference only, subject to change.

## Three Way/Two Stem Connection

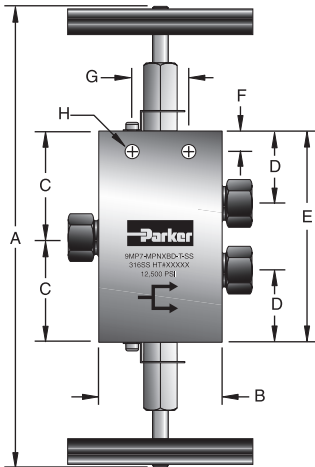

Panel Hole Sizes  
Medium Pressure Needle Valve Panel Mount

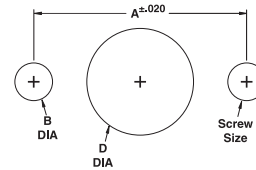

Valve Size	A	B	Screw Size	D
4 & 6	1.25	.219	10 - 32	.75
8 & 9	1.375	.219	10 - 32	1.00
12	1.75	.219	10 - 32	1.19
16	2.50	.219	10 - 32	1.63

Tubing	Parker Part No.	PSI	Connection	Inches									
				Orifice	A	B	C	D	E	F	G	H	Th'k
1/4" O.D.	4MP7-MPNXBD-T-SS	15,000	1/4" MPI	0.125	5.75	2.50	1.70	1.19	3.38	0.38	1.25	0.22	1.00
3/8" O.D.	6MP7-MPNXBD-T-SS	15,000	3/8" MPI	0.203	5.75	2.50	1.70	1.19	3.38	0.38	1.25	0.22	1.00
1/2" O.D.	8MP7-MPNXBD-T-SS	15,000	1/2" MPI	0.313	8.38	3.00	2.56	1.75	5.13	0.50	1.38	0.34	1.38
9/16" O.D.	9MP7-MPNXBD-T-SS	15,000	9/16" MPI	0.313	8.38	3.00	2.56	1.75	5.13	0.50	1.38	0.34	1.38
3/4" O.D.	12MP7-MPNXBD-T-SS	15,000	3/4" MPI	0.438	9.75	3.00	3.25	2.25	6.50	0.63	1.75	0.44	1.38
3/4" O.D.	12MP7-MPNXBDH-T-SS	10,000	3/4" MPI	0.516	9.75	3.00	3.25	2.25	6.50	0.63	1.75	0.44	1.38
1" O.D.	16MP7-MPNXBD-T-SS	12,500	1" MPI	0.563	12.19	4.13	4.13	2.81	8.25	1.13	2.50	0.56	1.75
1" O.D.	16MP7-MPNXBDH-T-SS	10,000	1" MPI	0.688	12.19	4.13	4.13	2.81	8.25	1.13	2.50	0.56	1.75

Dimensions in inches/millimeters are for reference only, subject to change.

## Two Way Angle Valves (Replaceable Seat)

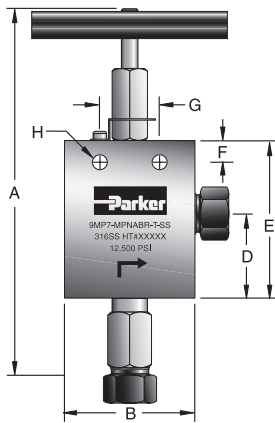

Panel Hole Sizes  
Medium Pressure Needle Valve Panel Mount

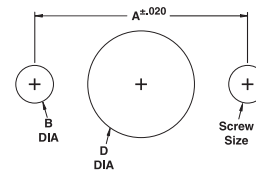

Valve Size	A	B	Screw Size	D
4 & 6	1.25	.219	10 - 32	.75
8 & 9	1.375	.219	10 - 32	1.00
12	1.75	.219	10 - 32	1.19
16	2.50	.219	10 - 32	1.63

Tubing	Parker Part No.	PSI	Connection	Inches									
				Orifice	A	B	C	D	E	F	G	H	Th'k
1/4" O.D.	4MP7-MPNABR-T-SS	15,000	1/4" MPI	0.125	5.87	2.50	-	1.38	2.57	0.38	1.25	0.22	1.00
3/8" O.D.	6MP7-MPNABR-T-SS	15,000	3/8" MPI	0.203	5.87	2.50	-	1.38	2.57	0.38	1.25	0.22	1.00
1/2" O.D.	8MP7-MPNABR-T-SS	15,000	1/2" MPI	0.313	8.25	3.00	-	2.00	3.63	0.50	1.38	0.34	1.38
9/16" O.D.	9MP7-MPNABR-T-SS	15,000	9/16" MPI	0.313	8.25	3.00	-	2.00	3.63	0.50	1.38	0.34	1.38
3/4" O.D.	12MP7-MPNABR-T-SS	15,000	3/4" MPI	0.438	8.88	3.00	-	2.00	4.25	0.63	1.75	0.44	1.38
3/4" O.D.	12MP7-MPNABRH-T-SS	10,000	3/4" MPI	0.516	8.88	3.00	-	2.00	4.25	0.63	1.75	0.44	1.38
1" O.D.	16MP7-MPNABR-T-SS	12,500	1" MPI	0.563	11.13	4.13	-	2.56	5.44	1.13	2.50	0.56	1.75
1" O.D.	16MP7-MPNABRH-T-SS	10,000	1" MPI	0.688	11.13	4.13	-	2.56	5.44	1.13	2.50	0.56	1.75

Dimensions in inches/millimeters are for reference only, subject to change.

## Over Critical Valves

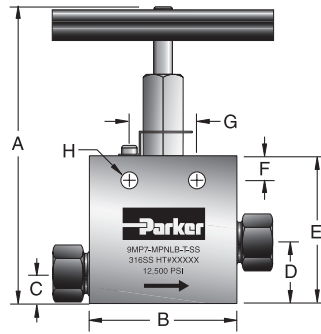

Dimensions in inches/millimeters are for reference only, subject to change.

Size	Parker Part No.	PSI	Connection	Orifice	A	B	C	D	E	F	G	H	Th'k
1/4" O.D.	4MP7-MPNLB-G-SS-OC	10,000	4MP7	0.125	4.50	2.50	0.50	0.94	2.13	0.38	1.25	0.22	0.75
3/8" O.D.	6MP7-MPNLB-G-SS-OC	10,000	6MP7	0.203	4.50	2.50	0.50	0.94	2.13	0.38	1.25	0.22	0.75
1/2" O.D.	8MP7-MPNLB-G-SS-OC	10,000	8MP7	0.313	6.26	3.00	0.63	1.25	3.00	0.50	1.38	0.34	1.00
9/16" O.D.	9MP7-MPNLB-G-SS-OC	10,000	9MP7	0.313	6.26	3.00	0.63	1.25	3.00	0.50	1.38	0.34	1.00
3/4" O.D.	12MP7-MPNLB-G-SS-OC	10,000	12MP7	0.438	7.00	3.00	0.75	1.50	3.75	0.63	1.75	0.44	1.38
1" O.D.	16MP7-MPNLB-G-SS-OC	10,000	16MP7	0.563	8.42	4.13	0.88	1.81	4.63	1.13	2.5	0.56	1.75
1/8" NPT	2F-MPNLB-G-SS-OC	10,000	1/8" NPTF	0.203	4.38	2.00	0.38	0.81	2.00	0.38	1.25	0.22	0.75
1/4" NPT	4F-MPNLB-G-SS-OC	10,000	1/4" NPTF	0.203	4.38	2.00	0.38	0.81	2.00	0.38	1.25	0.22	0.75
3/8" NPT	6F-MPNLB-G-SS-OC	10,000	3/8" NPTF	0.312	6.13	2.5	0.50	1.13	2.88	0.50	1.38	0.34	1.00
1/2" NPT	8F-MPNLB-G-SS-OC	10,000	1/2" NPTF	0.312	6.38	2.63	0.75	1.38	3.13	0.50	1.38	0.34	1.50
3/4" NPT	12F-MPNLB-G-SS-OC	10,000	3/4" NPTF	0.687	8.50	4.13	0.88	1.81	4.63	1.13	2.5	0.56	1.75
1" NPT	16F-MPNLB-G-SS-OC	10,000	1" NPTF	0.687	8.50	4.13	0.88	1.81	4.63	1.13	2.5	0.56	1.75

## Pressure vs. Temperature Chart

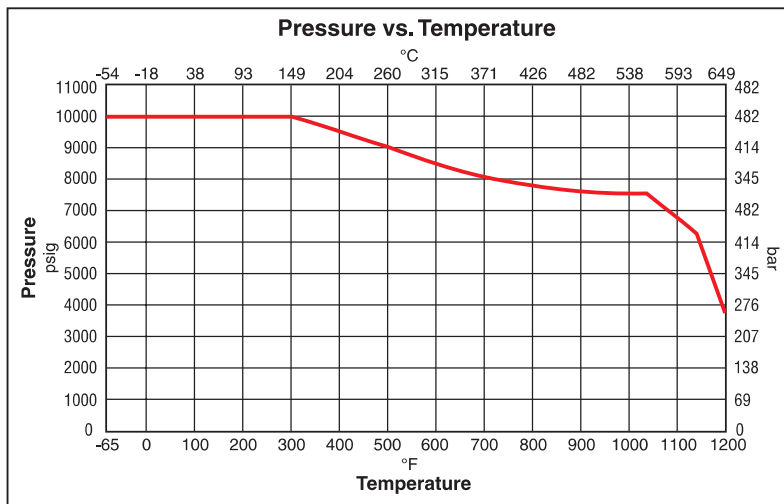

## Materials of Construction

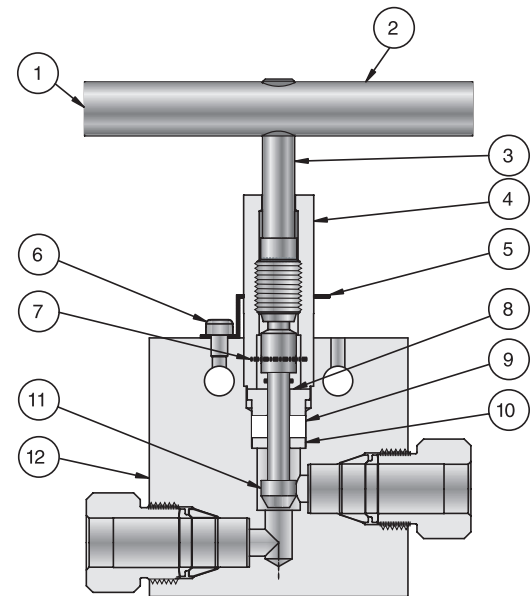

Item #	Description	Material
1	Set Screw	316SS
2	Handle	303SS
3	Upper Stem Assembly	416SS
4	Packing Gland	316SS
5	Locking Device	304SS
6	Lock Screw	304SS
7	Stem Pin	304SS
8	Top Packing Washer	416SS
9	Packing	Grafoil®
10	Bottom Pack Washer	316SS
11	Lower Stem	316SS
12	Body	316SS

Grafoil® is a registered trademark of GrafTech International Holdings, Inc.

## Bleed Valve

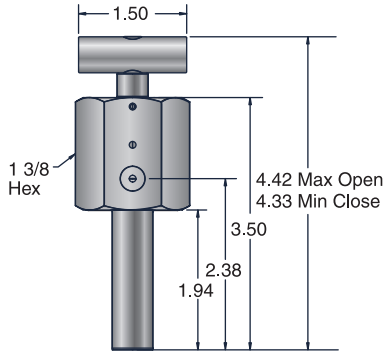

Parker Part No.	PSI	Connection
9T7-MPBV-V-SS	15,000	9/16" Tube Stub
9HM-MPBV-V-SS	30,000	9/16" High Pressure Male

## Materials of Construction

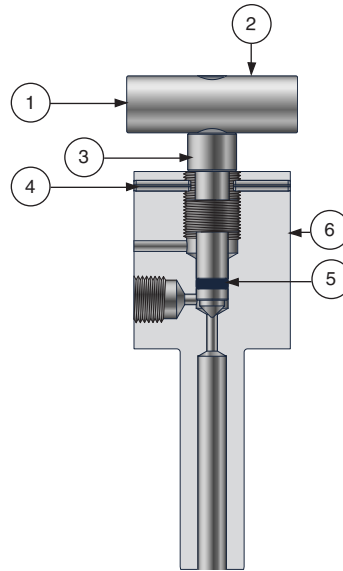

Item #	Qty	Description	Material
1	1	Soc Set Screw	300 Ser. SS
2	1	Handle	Aluminum
3	1	Stem	17-4PH-H900
4	2	Rolling Pin	420SS
5	1	O-Ring	Fluorocarbon Rubber*
6	1	Body	316SS

*Optional Seal Materials	
KZ	Highly Fluorinated Fluorocarbon Rubber
BN	Nitrile Rubber
EPR	Ethylene Propylene Rubber

Example: 9T7-MPBV-KZ-SS

## Gauge Valve

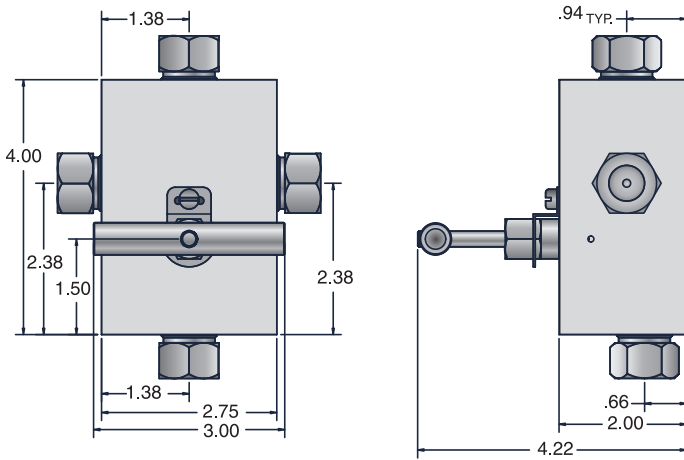

Parker Part No.	PSI	Connection
9MP7-MPGV-V-SS	15,000	9/16" MPI™
9HF-MPGV-V-SS	30,000	9/16" High Pressure Female

## Materials of Construction

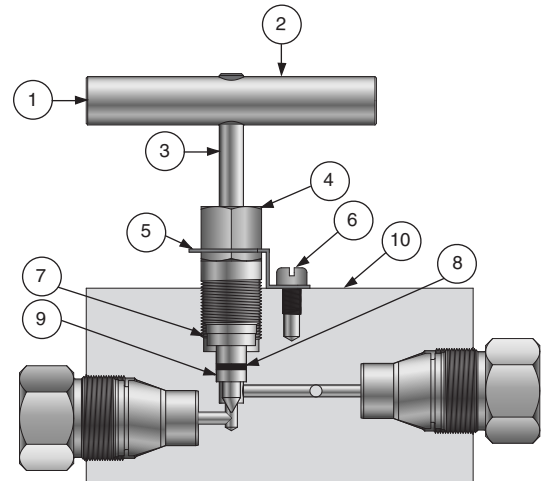

Item #	Qty	Description	Material
1	1	Soc Set Screw	Steel
2	1	Handle	Aluminum
3	1	Stem Assembly	17-4PH
4	1	Packing Gland	316SS
5	1	Locking Device	300 Ser. SS
6	1	10-32 x 1/4 Fill Hd Scr.	300 Ser. SS
7	1	Top Packing Washer	416SS
8	1	Packing	Fluorocarbon Rubber
9	1	Bottom Packing Washer	316SS
10	1	Body	316SS

MPN

## Sample Cylinders

Parker stainless steel sample cylinders provide safe containment for storage and transportation of both liquids and gases. These cylinders are DOT rated to 1800 psig (124 bar) at 70°F (21°C). Applications include hydrocarbon sampling in refineries, gas sampling in chromatography, and condensate sampling in fossil fuel and nuclear power plants.

ANSI/ASME B1.20.1 internal pipe threads are machined into both ends of each cylinder to engage external pipe connections of Parker valves, rupture disc units, or fittings.

### Stainless Steel Cylinders

Stainless steel sample cylinders are hot spun from seamless Type 316 tubing for integrity and corrosion resistance. The process provides a smooth internal flow transition through the neck to minimize pockets which can trap previous samples. Without the need for welding, the interior surface is free of any imperfections. As a result, less contamination will adhere to the interior surface when the cylinder is cleaned.

### Specifications

#### Pressure and temperature rating:

1800 psig (124 bar)  
-58°F to 450°F (-50°C to 232°C)

#### DOT-3E 1800:

75, 150, 300, and 500cc with 1/4" NPT threads

#### DOT-3A 1800:

1000 and 2250cc with 1/4" NPT threads

#### DOT-3A 1800:

3785cc (1 gallon) with 1/2" NPT threads



4F-SC75D-SS



4F-SC150D-SS



4F-SC300D-SS

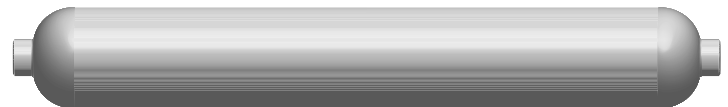

4F-SC500D-SS

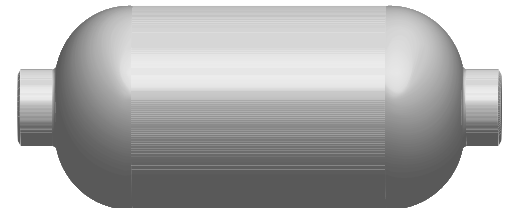

4F-SC1000D-SS

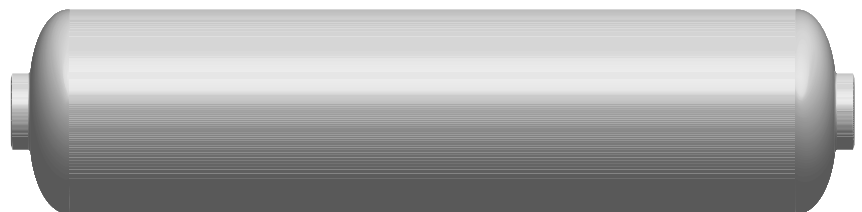

4F-SC2250D-SS-WC

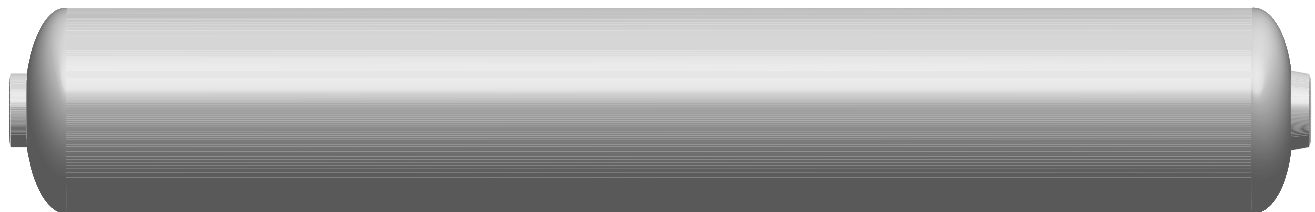

8F-SC1GD-SS-WC

Cyl &  
Acc

## Cylinder Design, Production and Testing

The design, manufacture and testing of steel sample cylinders is regulated by the US government in 49 CFR, Paragraphs 178.36 *Specification 3A; seamless steel cylinders* and 178.42 *Specification 3E; seamless steel cylinders*. Specification 3A deals with cylinders not over 1,000 pounds (455 kg) water capacity and Specification 3E is for cylinders having an outside diameter no greater than 2 inches (51 mm), with a length less than 2 feet (61 cm). Service pressure is limited to 1,800 psi (124 bar) for Parker Sample Cylinders.

The above regulations control all aspects of the design and production of sample cylinders. Material physical properties and chemical characteristics are controlled. Each cylinder must be hydrostatically tested between 3,000 and 4,500 psi (207 and 310 bar). In addition, one cylinder out of each lot of 500 or less must be subjected to a burst test and result in a safety factor on burst pressure of 3.3 minimum.

All cylinder tests must be inspected and verified by an independent inspection agency, and all test reports must be maintained for fifteen years. Each cylinder must also be marked and packaged in accordance with 49 CFR.

**Note:** DOT-3A 1800 cylinders must also be re-tested every five years at 3,000 psig (207 bar).

## How to Order / Dimensions

Material	DOT	Min. Internal Volume (cc)	Part Number		Dimensions (ref.)					
					Length		Outside Diameter		Approx. Weight	
			Single-End*	Double-End	inch	mm	inch	mm	lb.	kg
316 Stainless Steel	DOT-3E 1800	75	4F-SC75S-SS	4F-SC75D-SS	4.88	124	1.50	38	0.60	0.27
		150	4F-SC150S-SS	4F-SC150D-SS	8.13	206	1.50	38	1.00	0.45
		300	4F-SC300S-SS	4F-SC300D-SS	9.25	235	2.00	51	1.80	0.82
		500	4F-SC500S-SS	4F-SC500D-SS	13.88	352	2.00	51	2.50	1.14
	DOT-3A 1800	1000	4F-SC1000S-SS	4F-SC1000D-SS	9.50	241	4.00	102	7.50	3.41
		2250	4F-SC2250S-SS-WC	4F-SC2250D-SS-WC	16.5**	419**	4.00	102	12.00	5.45
		3785	8F-SC1GS-SS-WC	8F-SC1GD-SS-WC	25.5**	648**	4.00	102	17.80	8.09

\* A stainless steel pipe plug is supplied for use in one end of the cylinder when a single-ended cylinder is ordered.

\*\*Includes threaded neck rings and caps. Add 6-1/4" (159mm) to each end to include cap lengths.

Dimensions in inches/millimeters are for reference only, subject to change.

## V4LC Series Miniature Needle Valves

### Features

- ▶ Stainless steel construction
- ▶ Tapered bore PTFE packing
- ▶ Optional R stem (all metal, blunt tip) or K stem (PCTFE stem tip)
- ▶ Knurled aluminum handle
- ▶ Optional stem packings

### Specifications

**Pressure Rating:** 5000 psig CWP (345 bar)

#### Temperature Rating:

##### With PTFE packings –

R stem: -65°F to 450°F (-54°C to 232°C)

K stem: -65°F to 350°F (-54°C to 177°C)

##### With Nitrile rubber packing –

-30°F to 250°F (-34°C to 121°C)

##### With Fluorocarbon rubber packings –

-15°F to 400°F (-26°C to 204°C)

##### With Ethylene propylene rubber packing –

-70°F to 275°F (-21°C to 135°C)

##### With Neoprene rubber packing –

-65°F to 250°F (-54°C to 121°C)

**Ports:** ANSI/ASME B1.20.1; 1/4" external pipe threads

**Orifice:** 0.176" (4.5mm)

### How to Order

Dimensions in inches/millimeters are for reference only, subject to change.

The correct part number is easily derived from the following example and ordering chart. The five product characteristics required are coded as shown in the chart.

**Example 1** describes a needle valve with a K stem.

**Example 2** describes a needle valve with a R stem.

**Example 3** describes a needle valve with a K stem and optional elastomeric stem packaging of Nitrile rubber.

#### Examples:

**1:** 4M-V4LCK-SS (shown in the part number blocks below)

**2:** 4M-V4LCR-SS

**3:** 4M-V4LCK-BN-SS

4M	-	V4LC	K	-	BN	-	SS
Inlet Port		Valve Series	Stem Type		Optional Stem*		Body Material
4M		V4LC	K PCTFE R All metal, blunt tip		V Fluorocarbon Rubber BN Nitrile Rubber EPR Ethylene Propylene Rubber NE Neoprene Rubber		SS Stainless Steel

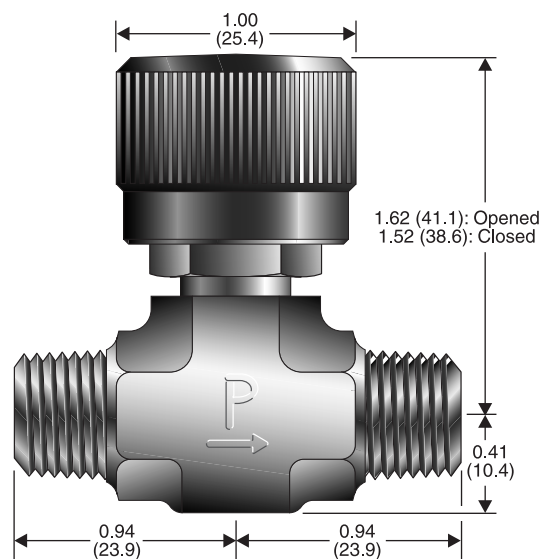

Model Shown: 4M-V4LCK-SS

( ) Denotes dimensions in millimeters

### Materials of Construction

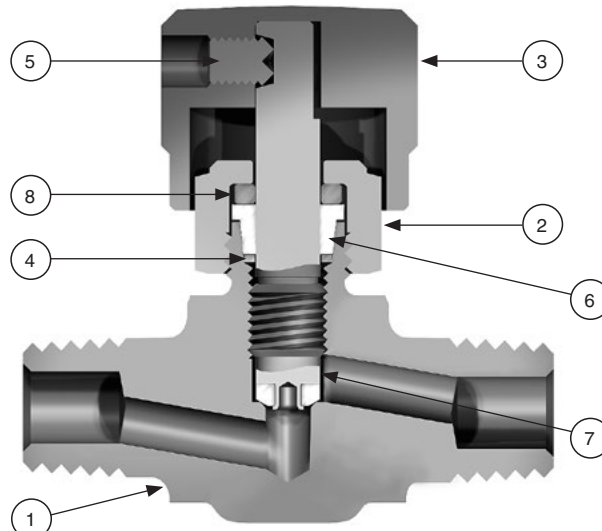

Item #	Description	Material
1	Body	ASTM A 182 Type F316
2	Packing Nut	ASTM A 479 Type 316
3	Handle	ASTM B 211 Alloy A92024
4	Lower Packing Washer	316 Stainless Steel
5	Handle Set Screw	316 Stainless Steel
6	Packing	PTFE
7	R Stem	ASTM A 276 Type 316
7	K Stem	ASTM A 276 Type 316 with PCTFE
8	Upper Packing Washer	Commercial Brass

\* Optional elastomeric O-ring stem seals and polymer seat materials are available - [See How to Order](#).  
Lubrication: Perfluorinated polyether



## Rupture Disc Units

### Features

- ▶ Designed for direct engagement to stainless steel sample cylinders for protection against overpressure.
- ▶ Pre-bulged 316 stainless steel rupture disc minimizes fragmentation upon burst.
- ▶ Pre-bulged disk provides close tolerance of the actual burst pressure.

### Specifications

#### Pressure Rating\*:

1800 psig at 70°F (124 bar at 21°C)

#### Temperature Rating:

With standard PTFE gasket –

-65°F to 150°F (-54°C to 66°C)

With optional metal gasket–

-65°F to 400°F (-54°C to 204°C)

**\*Note:** Contact your Parker Distributor for availability of optional rupture disc pressures from 160 psig to 5000 psig (11 bar to 345 bar).

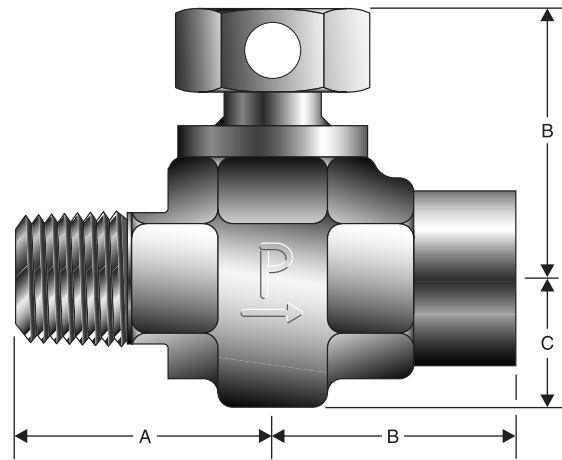

Model Shown: 4M4F-RV6L-18-SS

### Materials of Construction

Part Description	Material
Body	ASTM A 182 Type F316
Plug	ASTM A 479 Type 316
Ruptured Disk	AISI Type 316*
Gasket	PTFE or 316 Stainless Steel with PTFE Coating

**\*NOTE:** Ruptured disk material will be aluminum for pressures below 1260 psig (86 bar).

## Pressure vs. Temperature

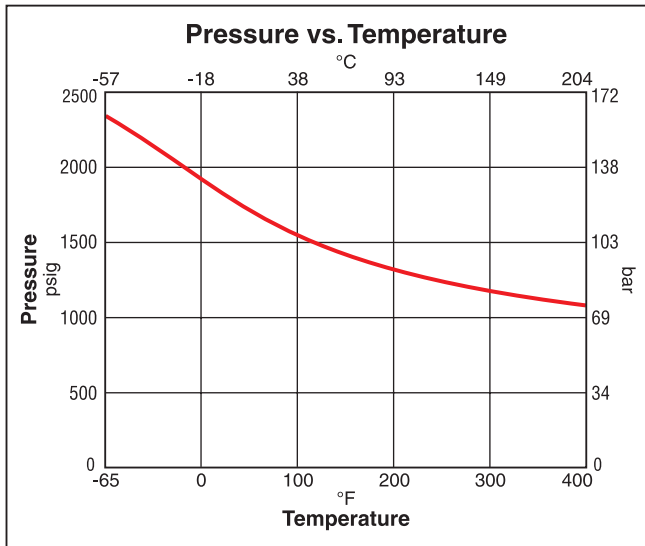

### Precautions

1. Ensure the minimum burst pressure rating of the Rupture Disc Unit is approximately 40% higher than the cylinder service (filling) pressure.
2. Do not use Rupture Disc Units in a location where the release of the contents may cause death, personal injury and property damage. Rupture Disc Units are a CGA Type CG-1 pressure relief device and are designed to release the entire contents of the cylinder to atmosphere.
3. Follow the minimum recommended practices for maintenance and inspection of pressure relief devices in CGA Pamphlet S-1.1. Inspect the rupture disc frequently. Preferably, replace the disc yearly. Temperature and pressure cycling, and corrosive media can affect the disc's burst pressure.
4. For additional information on Parker Rupture Disc Units, refer to any of the Maintenance and Installation Instructions for Rupture Discs and Combination Needle/Rupture Discs (INI-207, INI-219, MI-107, and MI-117).

Cyl &  
Acc

## How to Order / Dimensions

Dimensions in inches/millimeters are for reference only, subject to change.

Part Number	Inlet	Outlet	Dimensions							
			A		B		C		D	
			Inch	mm	Inch	mm	Inch	mm	Inch	mm
4M4F-RV6L-18-SS	1/4" MNPT	1/4" FNPT	1.00	25.4	1.00	25.4	0.53	13.5	1.15	29.2
8M8F-RV6L-18-SS	1/2" MNPT	1/2" MNPT	1.38	35.1	1.38	35.1	0.61	15.5	1.31	33.3

## Options

**Metal gasket** – Add suffix **-HT** to the end of the part number.

**Example:**

4M4F-RV6L-18-SS-HT

**Dip tubes** – ee page 49.

## RV6C Series Combination Rupture Disc / Needle Valves

### Features

- ▶ Combines the V4LC Series valve and the RV Series rupture disc unit into a small package
- ▶ Stainless steel construction
- ▶ Tapered bore PTFE packing
- ▶ K stem (PCTFE stem tip)
- ▶ Knurled aluminum handle
- ▶ Inline and angle patterns
- ▶ Optional stem packings

### Specifications

#### Pressure Rating:

- Valve – 5000 psig CWP (345 bar)
- Rupture Disc – 1800 psig (124 bar)

#### Temperature Rating:

- With standard PTFE gasket –**  
-65°F to 150°F (-54°C to 66°C)
- With optional metal gasket and proper seal –**  
-65°F to 400°F (-54°C to 204°C)
- With PTFE packing –**  
-65°F to 350°F (-54°C to 177°C)
- With Nitrile rubber packing –**  
-30°F to 250°F (-34°C to 121°C)
- With Fluorocarbon rubber packing –**  
-15°F to 400°F (-26°C to 204°C)
- With Ethylene propylene rubber packing –**  
-70°F to 275°F (-21°C to 135°C)
- With Neoprene rubber packing –**  
-65°F to 250°F (-54°C to 121°C)

#### Ports: ANSI/ASME B1.20.1;

- Inlet – 1/4" external pipe threads
- Outlet – 1/4" internal pipe threads

Orifice: 0.176" (4.5mm)

### Materials of Construction

Item #	Description	Material
1	Stem	ASTM A 276 Type 316 with PCTFE
2	Packing Nut	ASTM A 479 Type 316
3	Body	ASTM A 182 Type F316
4	Plug	ASTM A 479 Type 316
5	Handle Set Screw	316 Stainless Steel
6	Handle	ASTM B 211 Alloy A92024
7	Packing	PTFE
8	Lower Packing Washer	316 Stainless Steel
9	Gasket	PTFE or 316 Stainless Steel with PTFE coating
10	Rupture Disc	AISI Type 316
11	Upper Packing Washer	Commercial Brass

Lubrication: Perfluorinated polyether

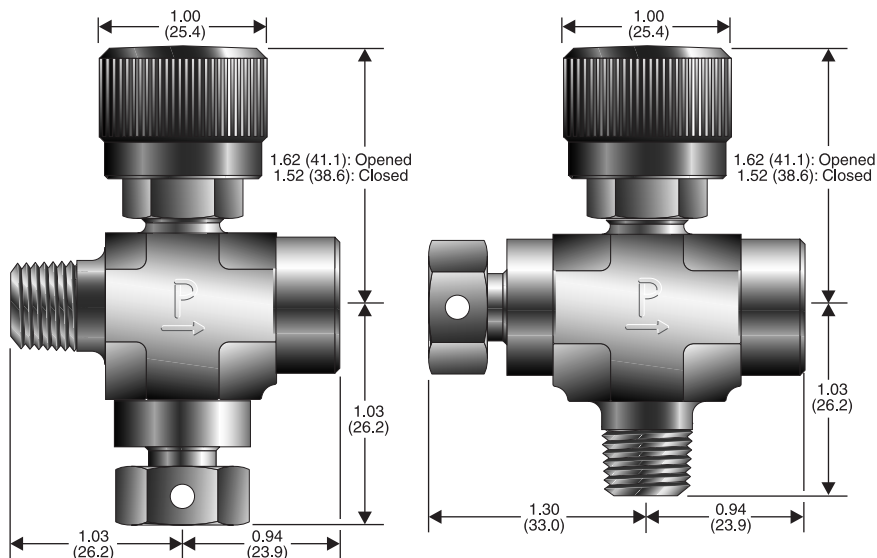

Model Shown:  
4M4F-RV6LCK-18-SS

Model Shown:  
4M4F-RV6ACK-18-SS

( ) Denotes dimensions in millimeters

### How to Order

Dimensions in inches/millimeters are for reference only, subject to change.

- Inline Pattern: 4M4F-RV6LCK-18-SS
- Angle Pattern: 4M4F-RV6ACK-18-SS

### NOTES:

- To obtain optional elastomeric stem packaging, insert one of the following designators prior to "-SS":
  - BN Nitrile rubber
  - V Fluorocarbon rubber
  - EPR Ethylene propylene rubber
  - NE Neoprene rubber.

**Example:** 4M4F-RV6LCK-18-V-SS

- To obtain the optional high temperature gasket, add the suffix **-HT** to the end of the part number.

**Example:** 4M4F-RV6LCK-18-V-SS-HT

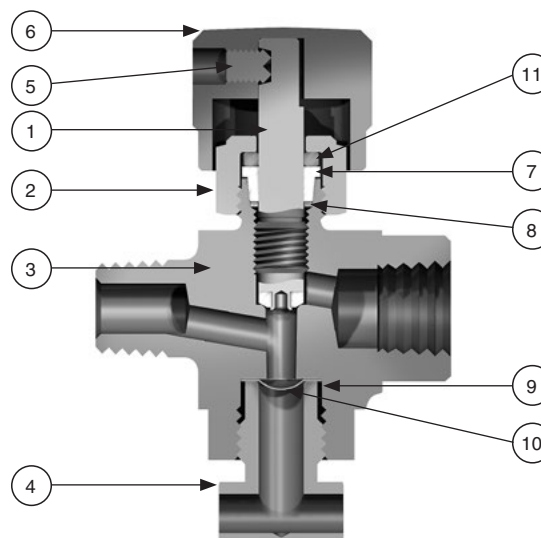

## Dip (Outage) Tube Valves and Fittings

Parker Sample Cylinder Valves and Rupture Disc Units may be fitted with customer specified dip tubes to prevent overfilling of cylinders by providing a vapor space in sample cylinders containing liquified gases. Parker Dip Tube Fittings permit the assembly of any valve with a dip tube.

### How to Order Dip Tubes with Sample Cylinder Valves and Rupture Disc Units

A 316 stainless steel dip tube will be supplied press fit to the Male NPT port of products when specified by adding the **dip tube length** to the end of the part number. The length is measured from the end of the forging.

**Example 1:** 4M4F-RV6L-18-SS-4. Describes a Rupture Disc Unit with a four inch (102mm) long dip tube.

**Example 2:** 4M4F-RV6LCK-18-SS-2. Describes a Combination Rupture Disc / Needle Valve with a two inch (51 mm) long dip tube.

### How to Order Dip Tube Fittings

Dimensions in inches/millimeters are for reference only, subject to change.

A 316 stainless steel dip tube will be supplied press fit to the Male NPT port of Male x Female Pipe Adapters. They are available with 1/4" or 1/2" NPT threads. Specify the custom DT6L fitting by adding the **dip tube length** to the end of the part number. The length is measured from the end of the forging.

**Example 1:** 4M4F-DT6L-SS-3. Describes a 1/4" MNPT x 1/4" FNPT Fitting with a 3 inch (76 mm) long dip tube.

**Example 2:** 8M8F-DT6L-SS-2. Describes a 1/2" MNPT x 1/2" FNPT Fitting with a 2 inch (51 mm) long dip tube.

**Note:** For further information on Dip (Outage) Tubes, refer to Parker Engineering Performance Report EPR4160.2

### Other Valves for use with Sample Cylinders

V Series Needle Valves  
SN Series Needle Valves

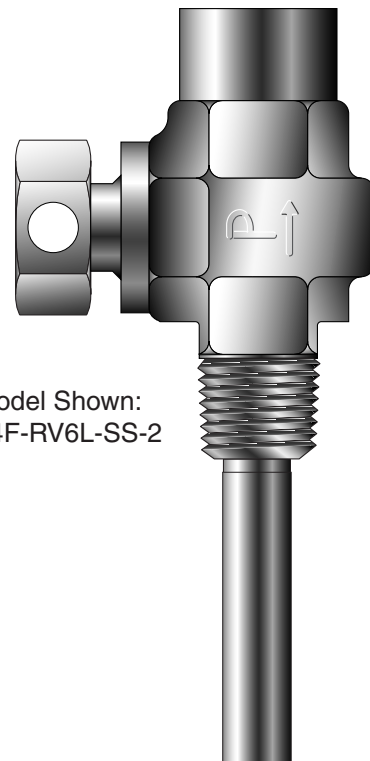

Model Shown:  
4M4F-RV6L-SS-2

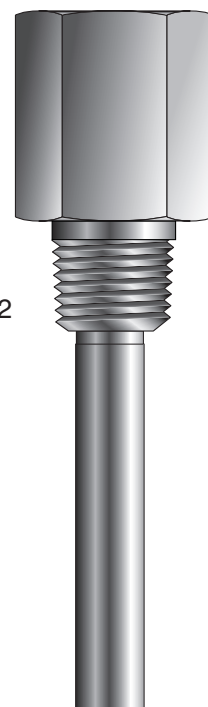

Model Shown:  
4M4F-DT6L-SS-2

Cyl &  
Acc

## Available End Connections

### Standard End Connections

**A** – Two ferrule A-LOK®  
compression port



**Z** – Single ferrule CPI™  
compression port



**F** – ANSI/ASME B1.20.1  
internal pipe threads

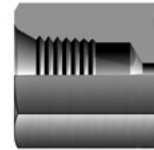

**M** – ANSI/ASME B1.20.1  
external pipe threads



**Q** – UltraSeal face seal port



**V** – VacuSeal face seal port



**MP7** – Parker MPI™  
(Medium Pressure Inverted)

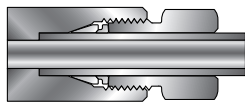

### Non-Standard End Connections

**TA** – Tube adapter connection



**F5** – SAE J1926/2, Part 2:  
Heavy-duty (S Series) stud ends



**G5** – SAE J1926/1, Part 1:  
Threaded port with O-ring seal in  
truncated housing

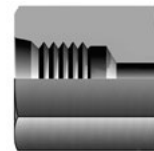

**L** – SAE J1453, Fitting – O-ring  
face seal – External thread with  
O-ring groove designed to seal with an  
elastomer against a sleeve



**KF** – British Standard BS 21  
(ISO 7-1), Internal pipe threads

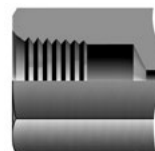

**KM** – British Standard BS 21  
(ISO 7-1), External pipe threads



End  
Conn

## Offer of Sale

The items described in this document and other documents and descriptions provided by Parker Hannifin Corporation, its subsidiaries and its authorized distributors ("Seller") are hereby offered for sale at prices to be established by Seller. This offer and its acceptance by any customer ("Buyer") shall be governed by all of the following Terms and Conditions. Buyer's order for any item described in its document, when communicated to Seller verbally, or in writing, shall constitute acceptance of this offer. All goods or work described will be referred to as "Products".

**1. Terms and Conditions.** Seller's willingness to offer Products, or accept an order for Products, to or from Buyer is expressly conditioned on Buyer's assent to these Terms and Conditions and to the terms and conditions found on-line at [www.parker.com/saleterms/](http://www.parker.com/saleterms/). Seller objects to any contrary or additional term or condition of Buyer's order or any other document issued by Buyer.

**2. Price Adjustments; Payments.** Prices stated on the reverse side or preceding pages of this document are valid for 30 days. After 30 days, Seller may change prices to reflect any increase in its costs resulting from state, federal or local legislation, price increases from its suppliers, or any change in the rate, charge, or classification of any carrier. The prices stated on the reverse or preceding pages of this document do not include any sales, use, or other taxes unless so stated specifically. Unless otherwise specified by Seller, all prices are F.O.B. Seller's facility, and payment is due 30 days from the date of invoice. After 30 days, Buyer shall pay interest on any unpaid invoices at the rate of 1.5% per month or the maximum allowable rate under applicable law.

**3. Delivery Dates; Title and Risk; Shipment.** All delivery dates are approximate and Seller shall not be responsible for any damages resulting from any delay. Regardless of the manner of shipment, title to any products and risk of loss or damage shall pass to Buyer upon tender to the carrier at Seller's facility (i.e., when it's on the truck, it's yours). Unless otherwise stated, Seller may exercise its judgment in choosing the carrier and means of delivery. No deferment of shipment at Buyers' request beyond the respective dates indicated will be made except on terms that will indemnify, defend and hold Seller harmless against all loss and additional expense. Buyer shall be responsible for any additional shipping charges incurred by Seller due to Buyer's changes in shipping, product specifications or in accordance with Section 13, herein.

**4. Warranty.** Seller warrants that the Products sold hereunder shall be free from defects in material or workmanship for a period of twelve months from the date of delivery to Buyer or 2,000 hours of normal use, whichever occurs first. This warranty is made only to Buyer and does not extend to anyone to whom Products are sold after purchased from Seller. The prices charged for Seller's products are based upon the exclusive limited warranty stated above, and upon the following disclaimer: **DISCLAIMER OF WARRANTY: THIS WARRANTY COMPRISES THE SOLE AND ENTIRE WARRANTY PERTAINING TO PRODUCTS PROVIDED HEREUNDER. SELLER DISCLAIMS ALL OTHER WARRANTIES, EXPRESS AND IMPLIED, INCLUDING MERCHANTABILITY AND FITNESS FOR A PARTICULAR PURPOSE.**

**5. Claims; Commencement of Actions.** Buyer shall promptly inspect all Products upon delivery. No claims for shortages will be allowed unless reported to the Seller within 10 days of delivery. No other claims against Seller will

be allowed unless asserted in writing within 60 days after delivery or, in the case of an alleged breach of warranty, within 30 days after the date within the warranty period on which the defect is or should have been discovered by Buyer. Any action based upon breach of this agreement or upon any other claim arising out of this sale (other than an action by Seller for any amount due to Seller from Buyer) must be commenced within thirteen months from the date of tender of delivery by Seller or, for a cause of action based upon an alleged breach of warranty, within thirteen months from the date within the warranty period on which the defect is or should have been discovered by Buyer.

**6. LIMITATION OF LIABILITY.** UPON NOTIFICATION, SELLER WILL, AT ITS OPTION, REPAIR OR REPLACE A DEFECTIVE PRODUCT, OR REFUND THE PURCHASE PRICE. IN NO EVENT SHALL SELLER BE LIABLE TO BUYER FOR ANY SPECIAL, INDIRECT, INCIDENTAL OR CONSEQUENTIAL DAMAGES ARISING OUT OF, OR AS THE RESULT OF, THE SALE, DELIVERY, NON-DELIVERY, SERVICING, USE OR LOSS OF USE OF THE PRODUCTS OR ANY PART THEREOF, OR FOR ANY CHARGES OR EXPENSES OF ANY NATURE INCURRED WITHOUT SELLER'S WRITTEN CONSENT, EVEN IF SELLER HAS BEEN NEGLIGENT, WHETHER IN CONTRACT, TORT OR OTHER LEGAL THEORY. IN NO EVENT SHALL SELLER'S LIABILITY UNDER ANY CLAIM MADE BY BUYER EXCEED THE PURCHASE PRICE OF THE PRODUCTS.

**7. Contingencies.** Seller shall not be liable for any default or delay in performance if caused by circumstances beyond the reasonable control of Seller.

**8. User Responsibility.** The user, through its own analysis and testing, is solely responsible for making the final selection of the system and Product and assuring that all performance, endurance, maintenance, safety and warning requirements of the application are met. The user must analyze all aspects of the application and follow applicable industry standards and Product information. If Seller provides Product or system options, the user is responsible for determining that such data and specifications are suitable and sufficient for all applications and reasonably foreseeable uses of the Products or systems.

**9. Loss to Buyer's Property.** Any designs, tools, patterns, materials, drawings, confidential information or equipment furnished by Buyer or any other items which become Buyer's property, may be considered obsolete and may be destroyed by Seller after two consecutive years have elapsed without Buyer placing an order for the items which are manufactured using such property. Seller shall not be responsible for any loss or damage to such property while it is in Seller's possession or control.

**10. Special Tooling.** A tooling charge may be imposed for any special tooling, including without limitation, dies, fixtures, molds and patterns, acquired to manufacture Products.

Such special tooling shall be and remain Seller's property notwithstanding payment of any charges by Buyer. In no event will Buyer acquire any interest in apparatus belonging to Seller which is utilized in the manufacture of the Products, even if such apparatus has been specially converted or adapted for such manufacture and notwithstanding any charges paid by Buyer. Unless otherwise agreed, Seller shall have the right to alter, discard or otherwise dispose of any special tooling or other property in its sole discretion at any time.

**11. Buyer's Obligation; Rights of Seller.** To secure payment of all sums due or otherwise, Seller shall retain a security interest in the goods delivered and this agreement shall be deemed a Security Agreement under the Uniform Commercial Code. Buyer authorizes Seller as its attorney to execute and file on Buyer's behalf all documents Seller deems necessary to perfect its security interest. Seller shall have a security interest in, and lien upon, any property of Buyer in Seller's possession as security for the payment of any amounts owed to Seller by Buyer.

**12. Improper use and Indemnity.** Buyer shall indemnify, defend, and hold Seller harmless from any claim, liability, damages, lawsuits, and costs (including attorney fees), whether for personal injury, property damage, patent, trademark or copyright infringement or any other claim, brought by or incurred by Buyer, Buyer's employees, or any other person, arising out of: (a) improper selection, improper application or other misuse of Products purchased by Buyer from Seller; (b) any act or omission, negligent or otherwise, of Buyer; (c) Seller's use of patterns, plans, drawings, or specifications furnished by Buyer to manufacture Product; or (d) Buyer's failure to comply with these terms and conditions. Seller shall not indemnify Buyer under any circumstance except as otherwise provided.

**13. Cancellations and Changes.** Orders shall not be subject to cancellation or change by Buyer for any reason, except with Seller's written consent and upon terms that will indemnify, defend and hold Seller harmless against all direct, incidental and consequential loss or damage. Seller may change product features, specifications, designs and availability with notice to Buyer.

**14. Limitation on Assignment.** Buyer may not assign its rights or obligations under this agreement without the prior written consent of Seller.

**15. Entire Agreement.** This agreement contains the entire agreement between the Buyer and Seller and constitutes the final, complete and exclusive expression of the terms of the agreement. All prior or contemporaneous written or oral agreements or negotiations with respect to the subject matter are herein merged.

**16. Waiver and Severability.** Failure to enforce any provision of this agreement will not waive that provision nor will any such failure prejudice Seller's right to enforce that provision in the future. Invalidation of any provision of this agreement by legislation or other rule of law shall not invalidate any other provision herein. The remaining provisions of this agreement will remain in full force and effect.

**17. Termination.** This agreement may be terminated by Seller for any reason and at any time by giving Buyer thirty (30) days written notice of termination. In addition, Seller may

by written notice immediately terminate this agreement for the following: (a) Buyer commits a breach of any provision of this agreement (b) the appointment of a trustee, receiver or custodian for all or any part of Buyer's property (c) the filing of a petition for relief in bankruptcy of the other Party on its own behalf, or by a third party (d) an assignment for the benefit of creditors, or (e) the dissolution or liquidation of the Buyer.

**18. Governing Law.** This agreement and the sale and delivery of all Products hereunder shall be deemed to have taken place in and shall be governed and construed in accordance with the laws of the State of Ohio, as applicable to contracts executed and wholly performed therein and without regard to conflicts of laws principles. Buyer irrevocably agrees and consents to the exclusive jurisdiction and venue of the courts of Cuyahoga County, Ohio with respect to any dispute, controversy or claim arising out of or relating to this agreement. Disputes between the parties shall not be settled by arbitration unless, after a dispute has arisen, both parties expressly agree in writing to arbitrate the dispute.

**19. Indemnity for Infringement of Intellectual Property Rights.** Seller shall have no liability for infringement of any patents, trademarks, copyrights, trade dress, trade secrets or similar rights except as provided in this Section. Seller will defend and indemnify Buyer against allegations of infringement of U.S. patents, U.S. trademarks, copyrights, trade dress and trade secrets ("Intellectual Property Rights"). Seller will defend at its expense and will pay the cost of any settlement or damages awarded in an action brought against Buyer based on an allegation that a Product sold pursuant to this Agreement infringes the Intellectual Property Rights of a third party. Seller's obligation to defend and indemnify Buyer is contingent on Buyer notifying Seller within ten (10) days after Buyer becomes aware of such allegations of infringement, and Seller having sole control over the defense of any allegations or actions including all negotiations for settlement or compromise. If a Product is subject to a claim that it infringes the Intellectual Property Rights of a third party, Seller may, at its sole expense and option, procure for Buyer the right to continue using the Product, replace or modify the Product so as to make it noninfringing, or offer to accept return of the Product and return the purchase price less a reasonable allowance for depreciation. Notwithstanding the foregoing, Seller shall have no liability for claims of infringement based on information provided by Buyer, or directed to Products delivered hereunder for which the designs are specified in whole or part by Buyer, or infringements resulting from the modification, combination or use in a system of any Product sold hereunder. The foregoing provisions of this Section shall constitute Seller's sole and exclusive liability and Buyer's sole and exclusive remedy for infringement of Intellectual Property Rights.

**20. Taxes.** Unless otherwise indicated, all prices and charges are exclusive of excise, sales, use, property, occupational or like taxes which may be imposed by any taxing authority upon the manufacture, sale or delivery of Products.

**21. Equal Opportunity Clause.** For the performance of government contracts and where dollar value of the Products exceed \$10,000, the equal employment opportunity clauses in Executive Order 11246, VEVRAA, and 41 C.F.R. §§ 60-1.4(a), 60-741.5(a), and 60-250.4, are hereby incorporated.

# Parker's Motion & Control Technologies

At Parker, we're guided by a relentless drive to help our customers become more productive and achieve higher levels of profitability by engineering the best systems for their requirements. It means looking at customer applications from many angles to find new ways to create value. Whatever the motion and control technology need, Parker has the experience, breadth of product and global reach to consistently deliver. No company knows more about motion and control technology than Parker. For further info call 1-800-C-Parker.



## AEROSPACE

### Key Markets

- Aircraft engines
- Business & general aviation
- Commercial transports
- Land-based weapons systems
- Military aircraft
- Missiles & launch vehicles
- Regional transports
- Unmanned aerial vehicles

### Key Products

- Flight control systems & components
- Fluid conveyance systems
- Fluid metering delivery & atomization devices
- Fuel systems & components
- Hydraulic systems & components
- Inert nitrogen generating systems
- Pneumatic systems & components
- Wheels & brakes



## CLIMATE CONTROL

### Key Markets

- Agriculture
- Air conditioning
- Food, beverage & dairy
- Life sciences & medical
- Precision cooling
- Processing
- Transportation

### Key Products

- CO<sub>2</sub> controls
- Electronic controllers
- Filter driers
- Hand shut-off valves
- Hose & fittings
- Pressure regulating valves
- Refrigerant distributors
- Safety relief valves
- Solenoid valves
- Thermostatic expansion valves

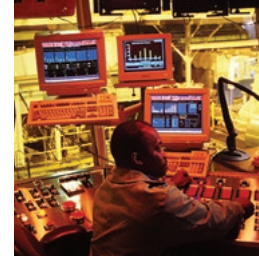

## ELECTROMECHANICAL

### Key Markets

- Aerospace
- Factory automation
- Life science & medical
- Machine tools
- Packaging machinery
- Paper machinery
- Plastics machinery & converting
- Primary metals
- Semiconductor & electronics
- Textile
- Wire & cable

### Key Products

- AC/DC drives & systems
- Electric actuators, gantry robots & slides
- Electrohydraulic actuation systems
- Electromechanical actuation systems
- Human machine interface
- Linear motors
- Stepper motors, servo motors, drives & controls
- Structural extrusions



## FILTRATION

### Key Markets

- Food & beverage
- Industrial machinery
- Life sciences
- Marine
- Mobile equipment
- Oil & gas
- Power generation
- Process
- Transportation

### Key Products

- Analytical gas generators
- Compressed air & gas filters
- Condition monitoring
- Engine air, fuel & oil filtration & systems
- Hydraulic, lubrication & coolant filters
- Process, chemical, water & microfiltration filters
- Nitrogen, hydrogen & zero air generators



## FLUID & GAS HANDLING

### Key Markets

- Aerospace
- Agriculture
- Bulk chemical handling
- Construction machinery
- Food & beverage
- Fuel & gas delivery
- Industrial machinery
- Mobile
- Oil & gas
- Transportation
- Welding

### Key Products

- Brass fittings & valves
- Diagnostic equipment
- Fluid conveyance systems
- Industrial hose
- PTFE & PFA hose, tubing & plastic fittings
- Rubber & thermoplastic hose & couplings
- Tube fittings & adapters
- Quick disconnects



## HYDRAULICS

### Key Markets

- Aerospace
- Aerial lift
- Agriculture
- Construction machinery
- Forestry
- Industrial machinery
- Mining
- Oil & gas
- Power generation & energy
- Truck hydraulics

### Key Products

- Diagnostic equipment
- Hydraulic cylinders & accumulators
- Hydraulic motors & pumps
- Hydraulic systems
- Hydraulic valves & controls
- Power take-offs
- Rubber & thermoplastic hose & couplings
- Tube fittings & adapters
- Quick disconnects

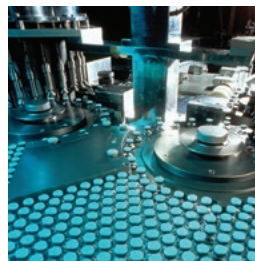

## PNEUMATICS

### Key Markets

- Aerospace
- Conveyor & material handling
- Factory automation
- Life science & medical
- Machine tools
- Packaging machinery
- Transportation & automotive

### Key Products

- Air preparation
- Brass fittings & valves
- Manifolds
- Pneumatic accessories
- Pneumatic actuators & grippers
- Pneumatic valves & controls
- Quick disconnects
- Rotary actuators
- Rubber & thermoplastic hose & couplings
- Structural extrusions
- Thermoplastic tubing & fittings
- Vacuum generators, cups & sensors



## PROCESS CONTROL

### Key Markets

- Chemical & refining
- Food, beverage & dairy
- Medical & dental
- Microelectronics
- Oil & gas
- Power generation

### Key Products

- Analytical sample conditioning products & systems
- Fluoropolymer chemical delivery fittings, valves & pumps
- High purity gas delivery fittings, valves & regulators
- Instrumentation fittings, valves & regulators
- Medium pressure fittings & valves
- Process control manifolds



## SEALING & SHIELDING

### Key Markets

- Aerospace
- Chemical processing
- Consumer
- Energy, oil & gas
- Fluid power
- General industrial
- Information technology
- Life sciences
- Military
- Semiconductor
- Telecommunications
- Transportation

### Key Products

- Dynamic seals
- Elastomeric o-rings
- EMI shielding
- Extruded & precision-cut, fabricated elastomeric seals
- Homogeneous & inserted elastomeric shapes
- High temperature metal seals
- Metal & plastic retained composite seals
- Thermal management



ENGINEERING YOUR SUCCESS.

# Parker Worldwide

## Europe, Middle East, Africa

**AE – United Arab Emirates,**  
Dubai  
Tel: +971 4 8127100  
parker.me@parker.com

**AT – Austria,** Wiener Neustadt  
Tel: +43 (0)2622 23501-0  
parker.austria@parker.com

**AT – Eastern Europe,** Wiener  
Neustadt  
Tel: +43 (0)2622 23501 900  
parker.easteurope@parker.com

**AZ – Azerbaijan,** Baku  
Tel: +994 50 2233 458  
parker.azerbaijan@parker.com

**BE/LU – Belgium,** Nivelles  
Tel: +32 (0)67 280 900  
parker.belgium@parker.com

**BG – Bulgaria,** Sofia  
Tel: +359 2 980 1344  
parker.bulgaria@parker.com

**BY – Belarus,** Minsk  
Tel: +375 17 209 9399  
parker.belarus@parker.com

**CH – Switzerland,** Etoy  
Tel: +41 (0)21 821 87 00  
parker.switzerland@parker.com

**CZ – Czech Republic,** Klecany  
Tel: +420 284 083 111  
parker.czechrepublic@parker.com

**DE – Germany,** Kaarst  
Tel: +49 (0)2131 4016 0  
parker.germany@parker.com

**DK – Denmark,** Ballerup  
Tel: +45 43 56 04 00  
parker.denmark@parker.com

**ES – Spain,** Madrid  
Tel: +34 902 330 001  
parker.spain@parker.com

**FI – Finland,** Vantaa  
Tel: +358 (0)20 753 2500  
parker.finland@parker.com

**FR – France,** Contamine s/Arve  
Tel: +33 (0)4 50 25 80 25  
parker.france@parker.com

**GR – Greece,** Athens  
Tel: +30 210 933 6450  
parker.greece@parker.com

**HU – Hungary,** Budaörs  
Tel: +36 23 885 470  
parker.hungary@parker.com

**IE – Ireland,** Dublin  
Tel: +353 (0)1 466 6370  
parker.ireland@parker.com

**IT – Italy,** Corsico (MI)  
Tel: +39 02 45 19 21  
parker.italy@parker.com

**KZ – Kazakhstan,** Almaty  
Tel: +7 7273 561 000  
parker.easteurope@parker.com

**NL – The Netherlands,** Oldenzaal  
Tel: +31 (0)541 585 000  
parker.nl@parker.com

**NO – Norway,** Asker  
Tel: +47 66 75 34 00  
parker.norway@parker.com

**PL – Poland,** Warsaw  
Tel: +48 (0)22 573 24 00  
parker.poland@parker.com

**PT – Portugal,** Leca da Palmeira  
Tel: +351 22 999 7360  
parker.portugal@parker.com

**RO – Romania,** Bucharest  
Tel: +40 21 252 1382  
parker.romania@parker.com

**RU – Russia,** Moscow  
Tel: +7 495 645-2156  
parker.russia@parker.com

**SE – Sweden,** Spånga  
Tel: +46 (0)8 59 79 50 00  
parker.sweden@parker.com

**SK – Slovakia,** Banská Bystrica  
Tel: +421 484 162 252  
parker.slovakia@parker.com

**SL – Slovenia,** Novo Mesto  
Tel: +386 7 337 6650  
parker.slovenia@parker.com

**TR – Turkey,** Istanbul  
Tel: +90 216 4997081  
parker.turkey@parker.com

**UA – Ukraine,** Kiev  
Tel: +380 44 494 2731  
parker.ukraine@parker.com

**UK – United Kingdom,** Warwick  
Tel: +44 (0)1926 317 878  
parker.uk@parker.com

**ZA – South Africa,** Kempton Park  
Tel: +27 (0)11 961 0700  
parker.southafrica@parker.com

## North America

**CA – Canada,** Milton, Ontario  
Tel: +1 905 693 3000

**US – USA,** Cleveland  
Tel: +1 216 896 3000

## Asia Pacific

**AU – Australia,** Castle Hill  
Tel: +61 (0)2-9634 7777

**CN – China,** Shanghai  
Tel: +86 21 2899 5000

**HK – Hong Kong**  
Tel: +852 2428 8008

**IN – India,** Mumbai  
Tel: +91 22 6513 7081-85

**JP – Japan,** Tokyo  
Tel: +81 (0)3 6408 3901

**KR – South Korea,** Seoul  
Tel: +82 2 559 0400

**MY – Malaysia,** Shah Alam  
Tel: +60 3 7849 0800

**NZ – New Zealand,** Mt Wellington  
Tel: +64 9 574 1744

**SG – Singapore**  
Tel: +65 6887 6300

**TH – Thailand,** Bangkok  
Tel: +662 186 7000-99

**TW – Taiwan,** Taipei  
Tel: +886 2 2298 8987

## South America

**AR – Argentina,** Buenos Aires  
Tel: +54 3327 44 4129

**BR – Brazil,** Sao Jose dos Campos  
Tel: +55 800 727 5374

**CL – Chile,** Santiago  
Tel: +56 2 623 1216

**MX – Mexico,** Toluca  
Tel: +52 72 2275 4200

