

PCO2

Carbon Dioxide Quality Incident Protection Systems
for the sparkling beverage industry - production plant



PCO2 Carbon Dioxide Quality Incident Protection Systems from Parker domnick hunter offer a comprehensive solution to preserve and guarantee the quality of gaseous carbon dioxide used in sparkling beverage bottling.

Using multi-layer adsorbant technology, the PCO2 range includes Maxi PCO2 and Mplus PCO2 for plant scale protection.

Operating as a Quality Incident Protection removing a wide range of potential carbon dioxide impurities, the system guarantees the gas quality so it remains within industry and company guidelines, preventing detrimental consequences to the finished end beverage, producers reputation and their bottom-line.

PCO2 is the beverage industry preferred choice and is installed in over 150 countries worldwide.

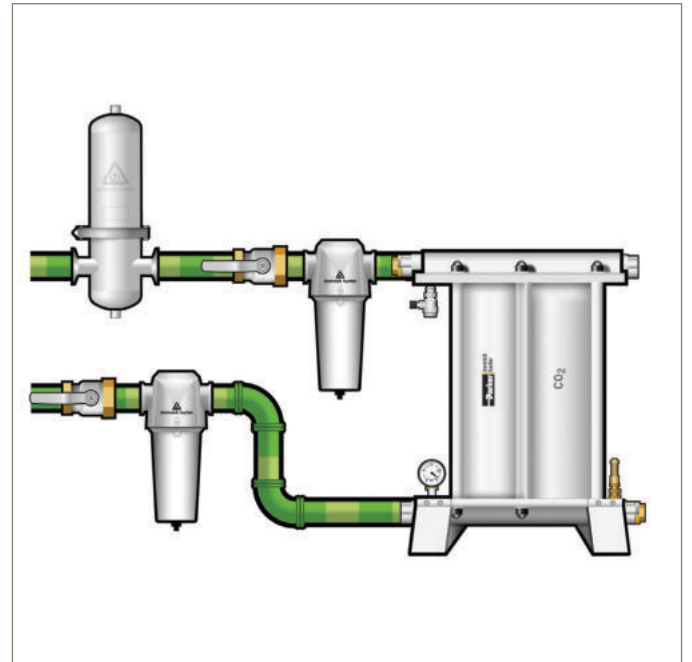

Contact Information:

Parker Hannifin Corporation
Finite Airtek Filtration Division
New York, USA
T 716 686 6400 F 877 857 3800
Toll Free 1-855-587-9323

Sales Office

Ontario, Canada
T 905 693 3000 F 866 958 1306
Toll Free 1-888-342-2623

www.parker.com/faf

Features:

- **Comprehensive six stage technology**
- **Simple installation**
- **Compact design**
- **Low maintenance**
- **Low pressure drop**
- **Meets ISO9001:2000 standards**
- **Materials of construction independent verifications to comply with FDA Code of Federal Regulations title 21 CFR**

Benefits:

- **Carbon dioxide quality guaranteed**
Effective in removing a combination of potential impurities and contaminants
- **Protection against impurities known to create beverage flavor defects**
Helps avoid product spoilage and protects bottlers reputation
- **Ensures carbon dioxide meets industry and company specifications and guidelines**
Cleans 'out of specification' gas back within beverage quality guidelines
- **International sales and service support**
Over 20 years experience. Purecare preventative maintenance option available

Product Selection

Data is based on 300 psi g (20.7 bar g). For flow rates at other pressures, stated flow rates are at 300 psi g (20.7 bar g). For flows at other pressures apply the correction factors shown below.

Model	Flow Rate	
	Lb/h	Kg/h
Maxi PCO2 - 0	330	150
Maxi PCO2 - 1	661	300
Maxi PCO2 - 2	1322	600
Maxi PCO2 - 3	1980	900
MPlus PCO2 4000	4000	1814
MPlus PCO2 6000	6000	2722
MPlus PCO2 8000	8000	3629
MPlus PCO2 10000	10000	4537

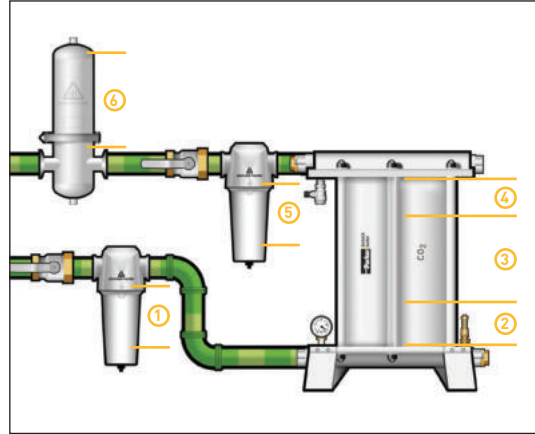

- Stage 1***
0.01 micron particle filtration
Removal of non-volatile organic residue (NVOR) and other contaminants down to 0.01 ppm
- Stage 2**
Removal of water vapor and partial removal of hydrocarbons
- Stage 3**
Primary removal of aromatic hydrocarbons (Benzene, Toluene etc and Acetaldehyde)
- Stage 4**
Removal of sulphur compounds (COS, H₂S, DMS etc)
- Stage 5***
0.01 micron particle filtration
- Stage 6****
Point of use VBACE sterile gas membrane. Hi Flow Tetpor II

* Supplied with every system
** Optional - Sterilizing Grade: consult Parker for operational use

Technical Data

	Unit	Maxi PCO2	MPlus PCO2
Max. Operating Pressure	psi g bar g	300 (350 optional) 20.7 (24.1 optional)	300 (350 optional) 20.7 (24.1 optional)
Min. Operating Temperature	°F °C	-4 -20	-4 -20
Max. Operating Temperature	°F °C	104 40	104 40
Inlet CO ₂ Quality*		ISBT beverage grade CO ₂	

*PCO2 CO₂ Systems are for gaseous CO₂ only

Pressure Correction Factors

Inlet Pressure	psi g	44	58	73	87	102	116	130	145	160	174	189
	bar g	3	4	5	6	7	8	9	10	11	12	13
Correction factor		0.19	0.23	0.28	0.33	0.38	0.42	0.47	0.52	0.57	0.61	0.66

Inlet Pressure	psi g	203	218	232	247	261	275	290	304	319	333	348
	bar g	14	15	16	17	18	19	20	21	22	23	24
Correction factor		0.71	0.76	0.80	0.85	0.90	0.95	1	1	1	1	1

Weights and Dimensions

Model	Systems Connections	Height (H)		Width (W)		Depth (D)		Clearance*		Weight	
		ins	mm	ins	mm	ins	mm	ins	mm	lbs	kg
Maxi PCO2 - 0	1" NPT	24.2	615	9.8	250	12.7	322	20.0	510	70	32
Maxi PCO2 - 1	1" NPT	24.5	621	9.8	250	18.3	464	20.0	510	106	48
Maxi PCO2 - 2	1" NPT	24.5	621	9.8	250	31.0	788	20.0	510	203	92
Maxi PCO2 - 3	1" NPT	24.5	621	9.8	250	43.8	1113	20.0	510	287	130
MPlus PCO2 4000	2" NPT†	54.7	1390	17.7	450	29.2	741	45.5	1155	596	270
MPlus PCO2 6000	2" NPT†	54.7	1390	17.7	450	35.8	910	45.5	1155	768	348
MPlus PCO2 8000	2-1/2" NPT†	54.7	1390	17.7	450	42.5	1079	45.5	1155	955	434
MPlus PCO2 10000	3" NPT†	54.7	1390	17.7	450	50.0	1270	45.5	1155	1140	518

† 350 psi g (24.1 bar g) versions all 2" connections

*Clearance required for the removal and servicing of cartridges

For information on extended warranty and preventative maintenance contract availability, please contact your local sales office or visit www.parker.com/faf

©2013 Parker Hannifin Corporation. All rights reserved. Publication: 174004462_04_EN Rev 000 NA 08/2013



ENGINEERING YOUR SUCCESS.