



Industrial Tube Fittings Europe

Technical handbook

*Catalogue 4100-5/UK
May 2003*





For your safety!

Under certain circumstances, tube fittings can be subjected to extreme loadings such as vibration and uncontrolled pressure peaks.

Only by using genuine Parker Components and following Parker assembly instructions can you be assured of the reliability and safety of the products and their conformity to the applicable standards.

Failure to follow this rule can adversely affect the functional safety and reliability of products, cause personal injury, property damage, and result in loss of your guarantee rights.

Subject to alteration

© Copyright 2003, Parker Hannifin Corporation. All Rights Reserved.

Tube fittings catalogue/Table of contents

Introduction	page 1
Detailed table of contents	page 10
Function of fittings	A
Systematic fitting selection	B
Performance data	C
Dimensioning	D
Tube assembly	E
Fitting assembly	F
Trouble shooting guide	G
Tooling	H
DIN fittings	I
O-Lok® Plus	J
Triple-Lok® Plus	K
Weld fittings	L
High Pressure Hydraulic Flanges	M
Adapters	N
Valves	O
Rotary fittings	P
Parker SensoControl® Diagnostic equipment	Q
Tubes	R
Tube clamps	S
Custom Products	T
Alphanumerical index	U



The Tube Fittings Authority:

Performance Plus

Since 1929, Parker Hannifin Corporation has served the marketplace with dependable fluid power technology. Today, Parker offers more than 100,000 quality products for a broad range of industries and applications.

No other manufacturer presents a product line as broad as Parker's, nor an expertise as far-reaching in hydraulic and pneumatic systems and components. Much of that expertise originates with Parker's precision-made tube fittings, which were among the first products manufactured by the company. As such, they reflect Parker's ongoing commitment to excellence. With more than seventy years of experience in product design, engineering, applications technology and manufacturing, the Tube Fittings Division Europe holds a leadership position few other manufacturers can claim. This leadership is further heightened and enhanced by the sharing of technology only possible in Parker's corporate family.



Topflight Experience

Parker has used the background data and knowledge gained from important industrial, mobile, offshore and other applications to create the broadest and best performing line of standard tube fittings in the world.

Why is Parker a topflight manufacturer of fittings?

There are many reasons, but at the heart is the design and manufacturing excellence that goes into every Parker product.

Worldwide standardizing Activities

The Parker FluidConnectors Group supports the national and international standardizing activities. Experienced

Tube Fittings Division Europe

engineers from certain countries and Divisions give their input to national committees like SAE, BS, and DIN committees in cooperation with the users of the products. As a result, many ISO FluidConnector standards have been published. These ISO standards are the platform for the international trading, interchangeability and availability that is necessary for all globally operating companies using fluid power technology.



Worldwide Supplier

The Tube Fittings Division Europe manufactures high performance, soft-sealed tube fittings as part of the Parker Dry Technology programme, and traditional metallically-sealed tube fittings. The EO2-Plus fitting (metric bite type with elastomeric seal), EO2-FORM system and O-Lok-Plus® fitting (O-ring face seal) form the Dry Technology „family“. EO-Plus fitting (metric bite type), 24° cone weld nipples, Triple-Lok-Plus® fitting (37° flare) and Pipe Adapters are the metallically sealed group. In addition, Ferulok fittings (inch tube bite type), Intru-Lok (Brass flareless) and JIS fittings are available via the Tube Fittings Division in the USA. This variety makes up the broadest

line of tube fittings in the industry. Parts are manufactured with ISO 6149, metric, BSPP, BSPT, NPT, UNF, SAE straight threads and flange ports.

There are 6 manufacturing plants in Europe - UK (Derby, Cradley Heath), Germany (Bielefeld-Windelsbleiche, Schloß Holte), Austria (Wiener Neustadt) and Poland (Wroclaw). Some parts are shipped from the USA or manufactured locally in other places of the world. The fittings are stocked in the Parker Service Centers and are the choice of Original Equipment Manufacturers and Maintenance, Repair and Overhaul customers throughout the world.

PLUS

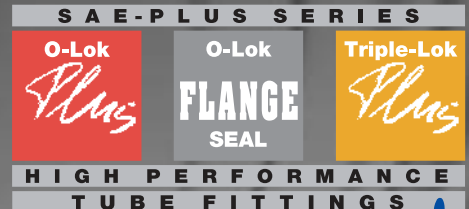

Dry Technology

It's more than just metal

The Parker Plus

How to identify Parker Quality

Each Parker product is marked with a Parker trademark.

The 24° items standardised in ISO 8434-1 & 4 are branded with "EO" – "Ermeto Original". Parker Triple-Lok®, O-Lok® and BSP-Adapter respectively are marked "P" – "Parker".

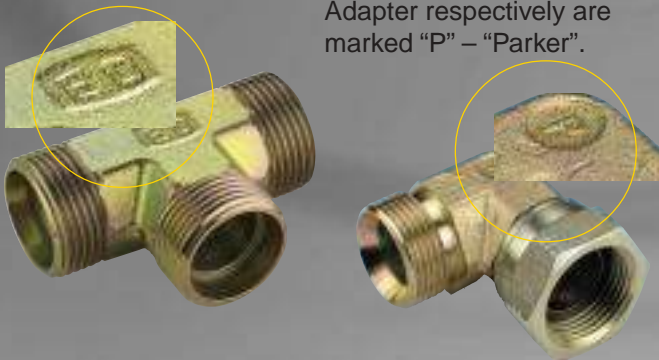

Stainless Steel items are supplied with "EO-DUR" nuts – sizes bigger than 12S have silver plated threads, smaller nuts are waxed. Furthermore the Stainless Steel products are provided with heat codes to enable Parker to issue certificates.

Innovative Performance
Parker does not keep its best ideas in the lab. The engineering departments from the Tube Fittings Division Europe in Bielefeld, Germany and Annemasse, France take them to the factory floor, integrating state-of-the art technology with innovative, yet practical products that consistently outperform current standards and competitive offerings.

Because of technical evolution new market requirements develop in hydraulic systems. Higher pressure, shorter cycle times and the idea of maintenance-free systems lead to the necessity of absolutely leak-free systems.

The Tube Fittings Division Europe developed the patented Parflange® tube preparation system as an alternative to preparing tube ends by brazing. This enabled the market for O-Lok® ORFS soft sealed fittings to expand strongly in Europe. Further, the soft sealed solution EO-2 was developed and launched in 1991 to provide the first soft-sealed alternative to the DPR-Progressive Ring and New Generation fitting technology was launched in 2001.



Derby
England



***Bielefeld-
Windelsbleiche***
Germany



Wiener Neustadt
Austria



Wroclaw
Poland

These facilities are very high volume machining and finishing plants supplying completed parts to the Divisions Service Centers throughout the world. The manufacturing plant in Poland is built to be near the new market of Eastern Europe. Millions of steel, stainless steel and brass fittings are manufactured out of forgings and bar materials per month. They are shipped to Customers around the world.

On the Cutting Edge

Focused Product Unit Custom Products

This business unit, located in Wiener Neustadt, Austria, is specialised in offering non-standard fittings according to customer requests. Due to modern CNC-machinery, they are able to produce a huge variety of customised and jump size fittings in different materials such as steel, stainless steel, brass and others. Virtually any straight or shape can be machined with a multitude of fitting systems and thread forms.



Highest Quality

Both bar stock and forged shapes are machined by state-of-the-art equipment into finished tube fittings that meet or exceed global standards.

All critical production steps are controlled by SPC (Statistical Process Control).

Parker has installed a Quality management system according to ISO 9001 in all locations.



Cradley Heath, England and Schloß Holte, Germany

These facilities are the metal forming plants supplying raw materials to the manufacturing locations throughout Europe. Thousands of tons of steel, stainless steel and brass are processed each year.

The Tube Fittings Division Europe forges its products from the best materials available to ensure strength and durability. For example, tube nuts are “cold-formed” from quality materials for close grained toughness. The result is a fitting with total reliability – a fitting that can stand up to years of service.



Chromate Protective Coating

Steel EO New Generation fittings are zinc plated and then chrome⁶-free chromated on a new state-of-the-art plating line providing corrosion protection equal to or exceeding ISO, DIN and SAE standards. The chrome⁶-free coating

meets already the Directive 2000/53/EC of the European Parliament and of the Council on end-of-life vehicles. This process is more environmentally friendly than other plating methods. The nuts are specially treated for reduced friction.



A Material Difference

High value TFDE fittings components

The manufacture of high quality, high value fittings components starts already with the ordering of tensile-tested raw materials; these have to comply with the Parker material specifications specially determined for the products concerned. All their properties are guaranteed by the process stages triggered both before and after manufacture, in order to meet ever-increasing market requirements.

Development- and manufacturing-related Tests

In order to guarantee high quality in the material employed and in the resulting tube fittings, tests are carried out continually in Tube Fittings Division Europe’s own laboratories and testing area. Forging blanks are subjected to additional magnetic particle crack testing as well as to colour penetration checks, so that cracks and faults can be excluded. Spectrographic analysis shows whether the high requirements for chemical composition have been met. Microscopic investigation and the determination of mechanical properties are a further guarantee of outstanding and consistent quality. The capacity of fittings systems to resist corrosion, and static and dynamic loads, are very thoroughly tested on the Division’s own test stands. The performance of these fittings components is further confirmed independently by tests at testing institutes and research bodies.



Inch and metric Production

All TFDE fittings are produced with external hexagons and body flats in metric sizes according to ISO 8434. This meets the requirements of the European market, where metric tools are used. For customer projects specified the USA, SAE fittings like Triple-Lok[®] and O-Lok[®] are also available with imperial flat size for inch-based tooling.

Whatever kind of knowledge and skills are needed – Parker field sales representatives and certified distributors offer a range of training. From Product Training to practical hands-on trainings a lot of variations to improve knowledge and effectiveness.

With a flexible training concept and the use of modern presentation techniques the Tube Fittings Division is able to offer individual customised practical in-house training. These trainings are completed with an up-to-date handbook, topical literature, wall charts and samples. After the training the customer gets all materials needed for further internal training events. With up-to-date product knowledge TFDE training team creates the best conditions to establish modern effective processes and selection of Parker TFDE hydraulic fittings.



Training Activities



Benefits for Customers and Parker Certified Distributors:

- **Reduced leakage**
 - **Reduce the loss of oil**
 - **“Better hydraulic system” as a sales argument for their vehicles**
 - **Reduction of cost by using easiest and fastest assembly techniques**
 - **Avoidance of maintenance, warranty costs and down town time**
 - **No scrap / no rework**
-

Software

Hose and Fittings InPHorm™

The Hose and Fittings inPHorm package is a powerful Windows-based software system designed to make selection of hoses, tubing and fittings very simple. Products from three divisions (Tube Fittings, Hose Products and Parflex) are included in this package. InPHorm can also generate a dimensioned CAD drawing of a selected fitting and add it to a Bill of Material.



CD-ROM

Part-No.: InPHorm-3400-CD

Specifications

- Systematic design for assistance in the proper selection of hose, tubing, hose fittings, hose assemblies, tube fittings and plastic fittings.
- Line sizer tool for sizing of hose, tubing and fittings
- Quote sheet for logging product selections (bill of material)
- Complete product summary reports, customised to your customer
- Customised distributor information file
- Fully parametric, customised CAD file output in DWG (R12), DXF, HPL and IGES
- Interchange tool for competitor, SAE and MS part numbers
- On-line user manual, in Adobe Acrobat format

Catalogues and Bulletins

For literature on TFDE products, please contact your closest service center.



4312/UK



4313/UK



4314/UK



4012/UK



4025/UK



4026/UK



4028/UK

Application Reports



4110/UK



4111/UK

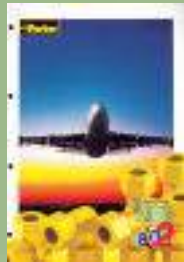

4112/UK



4113/UK



4114/UK



4115/UK



4116/UK

Software and Literature



4117/UK



4118/UK



4119/UK



4120/UK



4121/UK



4122/UK



4123/UK

Wall Charts

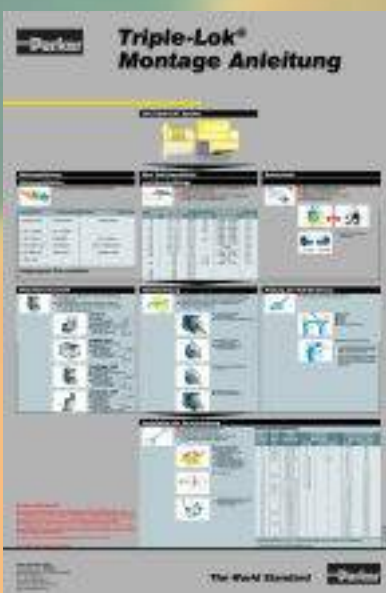

4310-P1/UK

Handbook



TFDEBOOKUK



Parker Store, Total Hose and Fittings Service

The first self-service shop for hydraulic and pneumatic connectors. This offers:

- More than 3,000 items in stock
- The immediate, on site making of hoses
- „Mr. ParkerStore“, the expert, trained and certified by Parker, is always available to help and to offer the best solutions to problems



Hose Doctor Service, Hydraulic Hose Replacement Service

This emergency service is available 24 hours a day and 7 days a week via free phone help line. The Hose Doctor Service van is a truly mobile workshop with a stock of hoses, tube fittings, adaptors, quick couplings and hydraulic lubricant. The technician is therefore able to replace any defective assembly, quickly and on site.

Value Added Services

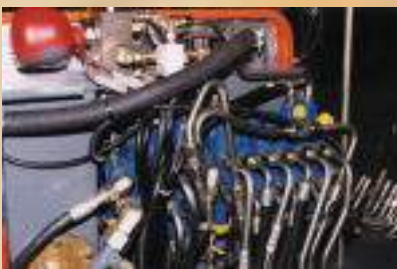

Technical Services

With this service, Parker offers customers a true partnership:

- Parker engineers study with the manufacturer the best circuit for its equipment
- They work on site, with the customer
- they are present from the conception up to installation and take charge of the training of operators



Kitting - personalised Orders

When a manufacturer regularly needs a group of connectors and accessories, Parker proposes to gather the items under one reference and delivers them as a kit.



Breadman

This service entails the delivery of products or Parker kits directly to the manufacturer's assembly line, work station or warehouse. This service can be provided by Parker Certified Distributors or by Parker.

Advantages for the customer: stocks are reduced, just-in-time delivery, less handling, no more stock-outs.



Contents

Detailed table of contents

Function of fittings	Section A	Performance data	Section C
Ermeto Original tube fittings	1	Pressure rating	2
EO-Plus: Progressive Stop Ring PSR for steel fittings	4	Pressure reductions and temperatures	2
EO Progressive Ring DPR for Stainless Steel fittings	6	Materials	3
EO2-Plus	9	Surface treatment	4
EO2-FORM	13	Fluid compatibility	5
EO Weld Nipple	16	Biodegradable oils	8
Introduction to O-Lok® Plus	18	Flow characteristics	9
Parflange® orbital flaring process and new Flange Seal system	22	Flow diameter and wall thickness	13
Introduction to Triple-Lok® Plus	25	Tube wall thickness	14
Adapters – introduction	30	Dimensioning	Section D
Thread configurations	32	Overview EO 24° cone connections	3
Systematic fitting selection	Section B	Not recommended	4
Introduction	2	EO 24° cone end (DIN 3861/ISO 8434-1)/dimension	4
Design criteria for fitting selection	2	EO 24°-DKO swivel connector (DIN 3861/DIN EN ISO 8434-4)/dimensions	5
Best solution	2	Overview O-Lok® connections	6–7
Material selection: Fitting material	3	O-Lok® end (ISO 8434-3/SAE J1453)/dimensions	8
Material selection: Sealing material	4	O-Lok® swivel connector (ISO 8434-3/SAE J1453)/dimensions	9
Tube end selection	5–6	Overview Triple-Lok® connections	10–11
LL/L/S Series selection for EO fittings	7	Triple-Lok® end (ISO 8434-2/SAE J1514)/dimensions	12
Flange type selection	8	Triple-Lok® swivel connector (ISO 8434-3/SAE J514)/dimensions	13
Port/Stud selection	9–11	DIN 60° cone end (DIN 7631)/dimensions	14
Orientable fitting selection	12–13	Adapter 60° cone end (ISO/DIS 8434-6)/dimensions	15
Standardization	14	NPSM Swivel adapters (SAE J516)/dimensions	16
Approvals	14	Port end dimensions for tube fittings	17–19
Fitting selection summary	15		
Dry technology versus traditional technology	15		

Detailed table of contents

Tube assembly	Section E	Impact flaring tools for metric and inch tube	29
		Portable 37° flaring device 1015	30
Fitting assembly	Section F	37° flaring tools for 1015 device and EOMAT II/III machine	31
		Assembly machines for O-Lok® and Triple-Lok®	32
Trouble shooting guide	Section G	Parflange® machine selection guide	32
		Parflange® 1025 workshop machine for O-Lok® and Triple-Lok®	33–34
Tooling	Section H	Parflange® 1040 production machine for O-Lok® and Triple-Lok®	35–36
Parker tube fabricating equipment	4	Tooling for Parflange® machines	37
Manual assembly tools for EO/EO-2	5	Parflange® tool identification	38
VOMO – Pre-assembly tools for EO/EO-2 tube connections	5	Parflange® tools for O-Lok®	39
KONU – Cone gauge for EO/EO-2 tube connections	6	Parflange® tools for O-Lok® (old version)	40
Checklist “depth measurement” for pre-assembly tooling (MOK and VOMO)	6	Parflange® tools for Triple-Lok®	41
Manual assembly devices for EO/EO-2 tube connections	7	Parflange® tools for Flange Seal	42
Machine selection guide	7	Lubricants	43
HVM-B Pre-assembly tool	8–9	Niromont lubricant for fitting assembly	43
EO-Karrymat portable pre-assembly device for EO tube connections	10	LUBSS/LUBCAN lubricant for flaring and forming tools	43
Assembly machines for EO/EO-2 and Triple-Lok®	11	Cutting and bending tools	44
Machine selection guide	11	AV 6/42 – Tube saw square	44
EOMAT II assembly and flaring machine	12–15	BAV 6/12 – Combined tube bending and cutting tool	45
EOMAT III assembly and flaring machine with electronic control	16–21	In-Ex tube deburring tool 226	45
EO PSR/DPR and EO-2 assembly tools for EOMAT/EO-KARRYMAT	22	Cutting and bending tools	46
F2 forming machine for EO2-FORM high pressure tube connections	23–26	BV 6/18 – Tube bending tool	46
Manual flaring tools for Triple-Lok® tubes	27	BV 20/25 – Tube bending tool	47
Flaring tool selection guide	27	WZK – Tool boxes	48
Manual flaring tools for Triple-Lok® tubes	28	Par-Lok wrench	48
Combination impact flarer 1004 for small dimension metric tube	28	O-ring assembly tools	49
Combination impact flarer 210A for small dimension inch tube	28	CORG O-ring installation tool for O-Lok®	49
		O-ring pick for O-Lok®	49
		Port cutting tools	50–51
		Counterbore tools and thread taps for metric ports	50

Contents

Detailed table of contents

Counterbore tools and thread taps for straight SAE thread	50	Visual index	12
Thread identification	52	SAE Flange clamps	15
Portboard	52	SAE Flange adapters	
Training equipment	53	EO 24° cone end	20
Sample case for assembly training	53	BSPP 60° cone end	24
Sample case for product presentation	54	Male NPT thread	26
		O-Lok® ORFS end	27
		Triple-Lok® 37° flare end	30
DIN fittings	Section I	Butt weld end	33
Contents	2–5	Socket weld end	38
How to order	6	SAE 4 bolt flanges	
How to order EO fittings	7	BSPP 60° cone end	41
		Female NPT thread	45
		Female metric and UN/UNF thread	48
O-Lok® Plus	Section J	EO 24° cone end	50
Contents	2–3	BSPP 60° cone end	52
How to order O-Lok® fittings	4	Triple-Lok® 37° flare end	54
		O-Lok® ORFS end	56
		Butt weld end	58
		Socket weld end	61
		Complete flange connections	65
Triple-Lok® Plus	Section K	SAE Flange accessories	68
Contents	2–3	SAE Junction blocks	74
How to order Triple-Lok® Plus fittings	4	Gear pump flanges	
		EO 24° cone end	78
		Male/Female BSPP thread	81
		Butt weld end	83
		Special pump size flanges	84
		Aluminium flanges	87
		ISO 6164 Square flanges	89
		Cetop square flanges	94
		Ball valve flanges	99
Weld fittings	Section L		
Contents	2		
High Pressure Hydraulic Flanges	Section M		
Introduction	4		
Design and construction	4		
Methods of connection	5		
How flange connections work	6		
Assembly of flanges	7		
Technical data	8		
Order codes screws and O-rings	9		
Features, advantages and benefits	10		
How to order	11		

Detailed table of contents

Adapters	Section N	Tube clamps	Section S
Contents	2–3	Contents	3
		Technical data	3
Valves	Section O	Material properties	4
Contents	2–5	Assembly instruction	5/6
		Light series (DIN 3015, part 1)	6
Rotary fittings	Section P	Heavy series (DIN 3015, part 2)	6
Contents	2	Double series (DIN 3015, part 3)	6
		Recommended clamp pitch	7
Parker SensoControl®		Pipe bend assembly	7
Diagnostic equipment	Section Q		
Contents	2	Custom Products	Section T
Tubes	Section R	Alphanumerical index	Section U
General recommendations for tubes	3		
Seamless EO steel tubes			
Material St. 37.4	4–5		
Seamless EO stainless steel tubes			
Material-No.: 1.4571/1.4541	6–7		
Seamless EO steel tubes Material C-Steel	7		
Seamless EO tube bends 90°			
Material St. 37.4 and 1.4571	8		



Function of fittings

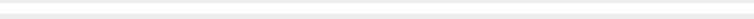



Index

Ermeto Original tube fittings – introduction A3

New Generation: High performance tube fittings A4

EO-Plus: Progressive Stop Ring PSR for steel fittings A6

EO-DUR progressive ring DPR for stainless steel fittings A8

EO2-Plus A11

EO2-Form A15

EO Weld nipple A18

Introduction To O-Lok® A20







Parflange® orbital flaring process and the Flange Seal* system A24

Introduction to Triple-Lok® A27

Adapters – introduction A30

Thread configurations A34

Ermeto Original tube fittings

Metal sealing	Soft seal bite type	Soft seal tube forming
 	  <i>Dry Technology</i>	  <i>Dry Technology</i>

Introduction:

The bite type fitting was designed by Ermeto in Germany in the early 1930's.

Ermeto-fittings soon became popular due to the simple assembly which basically just requires two wrenches. Today, the EO fitting is the most widely used bite-type fitting in the world.

EO fittings are designed for metric tube. All threads, hexagons, bores and other dimensions are purely metric. Historically it is based on German national standards 2353, DIN 3861, DIN 3859 and DIN 2353, which today are represented in the international standards ISO 8434.

EO fittings are recognised for the high pressure performance from a compact body. EO fittings are available in the three series for low, medium and high pressures (LL, L and S-Series). This allows cost savings and -space minimised solutions for each specific application.

EO fittings are recognised for the high pressure performance from a compact body. EO fittings are available in the three series for low, medium and high pressures (LL, L and S-Series). This allows cost savings and -space minimised solutions for each specific application.



Function of fittings



New Generation: High performance tube fittings

The new, chromium⁶-free fitting generation from Parker Ermeto is called EO-Plus for metallic sealed connections, EO2-Plus for Dry Technology systems and EO2-FORM for formed tube soft-sealed systems without cutting rings. The new generation is characterised by maximum safety even under extreme pressures of up to 800 bar nominal pressure.

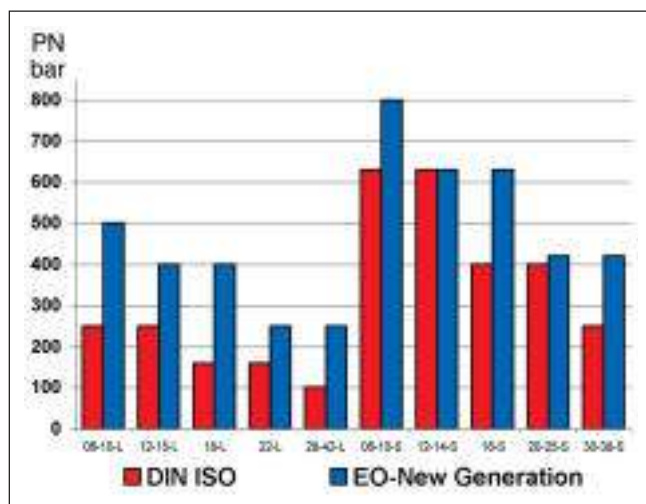

Nominal pressure ratings

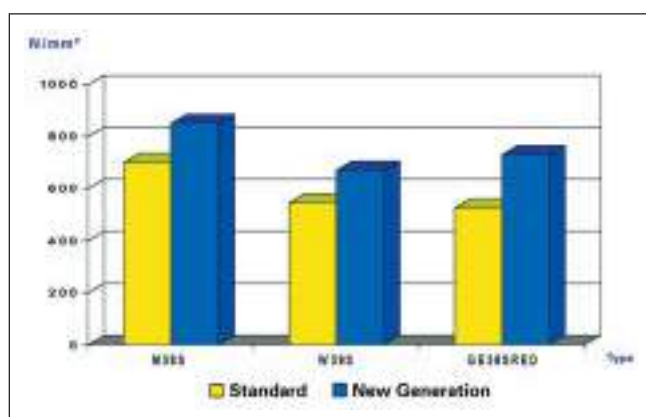

Material tensile strength

The new multifunctional PSR cutting ring, the heart of the EO-Plus fitting, ensures a uniquely simple and easy assembly through its multifunctional ring geometry.

The further development of the proven Dry Technology EO-2 concept is designated EO2-Plus and gives extremely high pressure ratings and greatly reduced tightening torques for the larger fitting sizes.

EO2-FORM is the new high pressure tube connection from Parker Ermeto. This concept unites the advantages of welded connections with those of EO-2 technology proven worldwide in millions of applications.

The New Generation from Parker Ermeto clearly exceeds the performance requirements of DIN/ISO standards: with its guaranteed 4-fold design factor, the new fitting generation can be used at the following nominal pressures in steel:

- Up to 500 bar in the L series
- Up to 800 bar in the S series
- A unique 420 bar in the 20 S–38 S sizes!

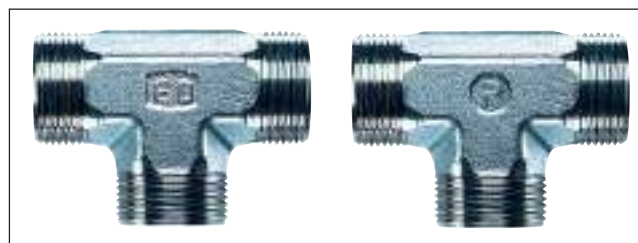

New forging design (front and back)

This extraordinary pressure and assembly performance can only be achieved by the use of even better and more resistant materials in combination with a special coating of individual components.

This greatly extends the application range and the user does not have to sacrifice any advantages. Thanks to the higher pressure levels, less expensive “L” series fittings can now be used instead of the heavier “S” series.

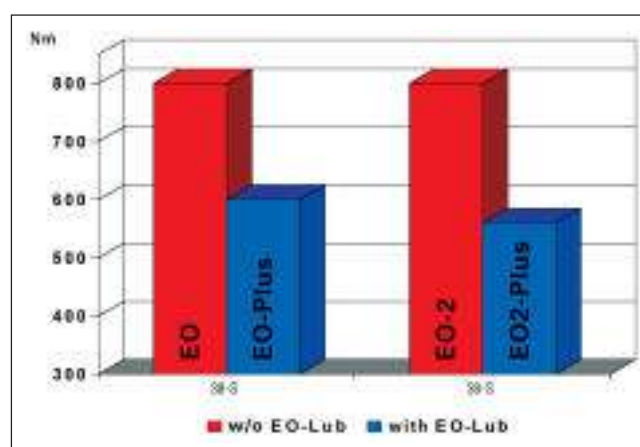

Assembly torques



The new high performance forging design with its considerably larger flats size makes assembly even safer and easier.

Through the application of a chromium⁶-free surface treatment, Parker Ermeto meets future requirements of the automotive industry today, and respects the directive of the European Parliament to eliminate the use of Chromium⁶. The removal of Chromium⁶ reflects Parker's ongoing commitment to an environmentally clean and safe production process. The additional "Plus": the corrosion resistance is increased to more than 500 hrs. to white rust.

The EO-LUB procedure is yet another innovation unique to Parker. In addition to the standard dry wax lubrication of the tube nuts, all larger fittings (25S/28L and above) are EO-LUB treated. EO-LUB reduces the assembly torques by approximately 25%, which makes assembly easier and prevents underassembly, the most common reason for bite-type tube fitting failure.

This latest fitting generation benefits from Parker's long years of experience combined with continuous innovation. It is made with our state-of-the-art production methods, controlled by the strictest quality assurance systems and procedures.

EO-Plus: Progressive Stop Ring PSR for steel fittings



Introduction

The original fitting system used worldwide in millions of applications is now available in a new design: more safety even under the highest pressure, chromium⁶-free surface treatment with significantly higher corrosion resistance, and considerably reduced tightening torques.

The ingenious invention of the cutting ring fitting was made by the founder of Parker Ermeto in the late nineteen twenties. In 1934, this idea was patented and today it is just as useful as it was on the very first day. Considering the range of applications, quality, reliability and functional safety, the principle of the Parker's cutting ring fitting has been a leading system up to today.

Of course, this has only been possible by continuously adapting the original invention from 1934 to the practical requirements of state of the art technology. Thus, the first Parker Ermeto cutting ring has little left in common with the latest multifunctional PSR cutting ring, the heart of EO-Plus.

The EO-Plus fitting meets the requirements of modern hydraulic systems. This is especially true for applications where the systems are exposed to extremely high loads.

EO-Plus is designed for metric tube and based on German Standards DIN 3861 and DIN 2353, which today are represented by the international standard ISO 8434-1. EO-Plus is available in "L"- and "S"-Series.

The PSR (Progressive Stop Ring) is available for the steel fitting range. For stainless steel applications, the Progressive ring DPR 71 is used and the Cutting ring for brass fittings and series LL.

EO-Plus fitting features

The EO-Plus fitting produces high pressure, leak free connection of tubes and components in fluid systems. The basic function of EO-Plus is the controlled progressive bite of the PSR into the tube due to a unique internal geometry.

The front cutting edge A has already started cutting into the tube before the second cutting edge B begins. As soon as both cutting edges have cut into the tube to the designed depth further advance is limited by the stop shape C and the new overtightening protection D. Additionally, the special form of the PSR with its dimples at the front shoulder section gives an assembly state control.

Owing to the design of both cutting edges and stop shape all forces arising are equally distributed. This distribution along with the specially designed interior collar E of the ring guarantees increased safety, particularly with regard to vibration and flexure stresses. Service vibration loading is not present in the areas of the tubing where the bite is made.

The stop shape as well as the overtightening protection cause a clear sharp increase in tightening forces. After assembly, a visible collar F of cut tube material must completely fill the space in front of the first cutting edge. A slight bowing up of the ring G is desirable. This spring effect provides permanent compensation for flexural vibration and settling effects in the thread of the fitting nuts.

Assembly

Assembly process is similar to EO-Progressive ring. See chapter E.

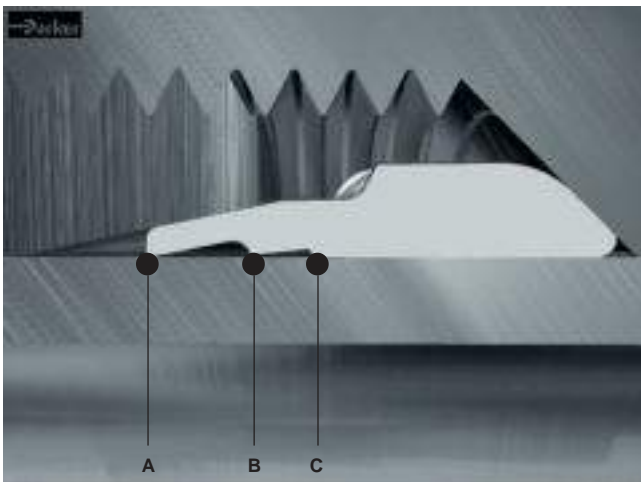

Before tightening the nut

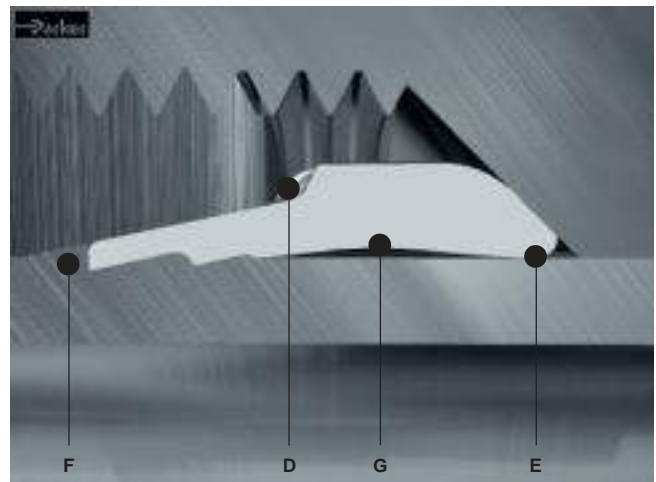

After tightening the nut

Features, advantages and benefits of EO-Plus fittings

Naturally all advantages of the proven EO Progressive ring fittings are also present in EO-Plus, however, the new EO-Plus Generation additionally offers the following:

- **Plus: Highest corrosion resistance** – The corrosion resistance is increased to more than 500 hours to white rust.
- **Plus: Increased pressure** – Due to the application of even better materials combined with the special processing of individual components, EO-Plus can be used in applications of up to 800 bar (S series) and 500 bar (L series). EO-Plus considerably exceeds the DIN/ISO requirements and guarantees a 4-fold design factor. Thanks to the higher pressure levels, less expensive “L” series fittings can now be used instead of the heavier “S” series, which also is of benefit in limited or tight space applications.
- **Plus: EO-LUB** – Due to the special treatment of the larger sized nuts by the EO-LUB procedure (25S/28L and larger), the tightening torques of EO-Plus fittings have been reduced by 25%. This makes assembly easier and prevents underassembly, the most common reason for tube fitting failure.
- **Plus: Safe assembly** – Two distinctive cutting edges provide a progressive increase of the tightening torque of the PSR. The noticeable end point of assembly contributes to maximum safety of assembly, and the multifunctional ring geometry prevents over-tightening.
- **Plus: Overtightening protection** – The special geometry of the PSR prevents the overassembly of EO-Plus fittings.
- **Plus: Spring effect** – Thanks to the spring effect, re-tightening of the fitting is not necessary. Upon the completion of the assembly (due to the geometry, material and heat treatment) an elastic initial tension is achieved which compensates displacement effects in the thread and at the bite point of the tube.
- **Plus: Chromium⁶-free** – Due to its chromium⁶-free treated surface, Parker Ermeto now meets the expected requirements to be expected in the automotive industry and the requirements issued by the European Parliament to eliminate the use of materials and surfaces containing chromium⁶. The removal of chromium⁶ reflects Parker’s ongoing commitment to an environmentally clean and safe production process.
- **Plus: Worldwide availability** – EO-Plus is available worldwide and meets the requirements of the applicable standards for 24° cutting ring fittings. The multifunctional PSR can be used with all types, series and dimensions of the wide range of EO-Plus fittings.



The new multifunctional PSR



Cranes – one of numerous applications for EO-Plus fittings

EO-DUR Progressive Ring DPR for stainless steel fittings

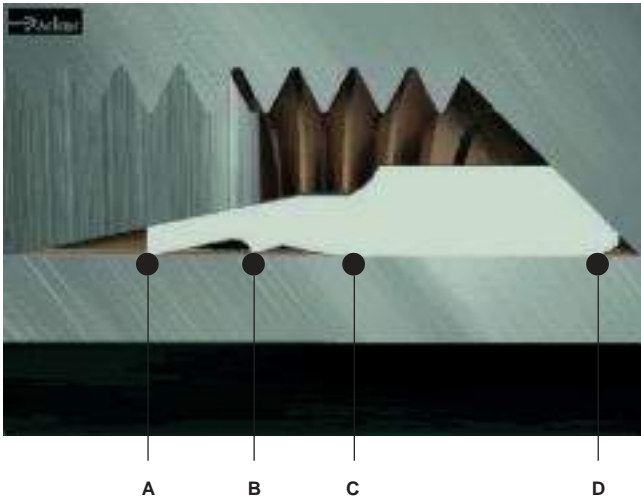

Before tightening the nut

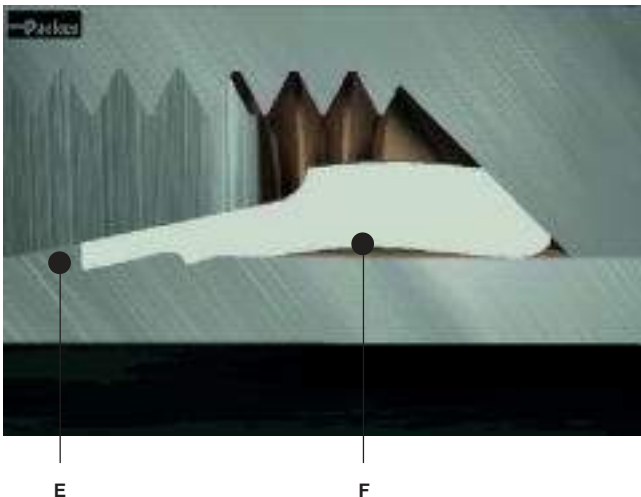

After tightening the nut

The proper assembly result is achieved by $1\frac{1}{2}$ turns of the nut.

The function of the EO-DUR stainless steel progressive ring fitting

The EO progressive ring fitting produces a low to high pressure, leak free connection of tubes and components in fluid systems. The basic function of the EO progressive ring is the controlled progressive bite of the ring into the tube due to its unique internal geometry. The design of the EO-DUR stainless steel progressive ring is based on three essential functions.

The front cutting edge (A) has already started cutting into the tube before the second cutting edge (B) starts. As soon as both cutting edges have cut into the tube to the designed depth further advance is limited by the stop shape (C).

Owing to the design of both cutting edges and stop shape all forces arising are equally distributed. This distribution

along with the specially designed interior collar (D) of the ring guarantees increased safety, particularly with regard to vibration and flexure stresses. The design and function of the cutting ring ensure that service vibration loading is not present in the areas of the tubing where the bite is made.

The stop shape causes a sharp increase in tightening forces which is perceptible. After assembly, a visible collar (E) of cut tube material must completely fill the space in front of the first cutting edge. With stainless steel tube and standpipe hose connections, the collar is smaller due to the harder material.

A slight bowing up of the ring (F) is desirable while this happens. This spring effect provides permanent compensation for flexural vibration and setting effects in the thread of the fitting nuts.

All EODUR stainless steel fittings show a special progressive ring design for best performance with stainless steel tubes. LL – series fittings and all brass fittings are equipped with a single bite “D”-ring.

The spring effect

$$\textcircled{1} + \textcircled{2} + \textcircled{3} = 1\frac{1}{2} \text{ } \curvearrowright$$

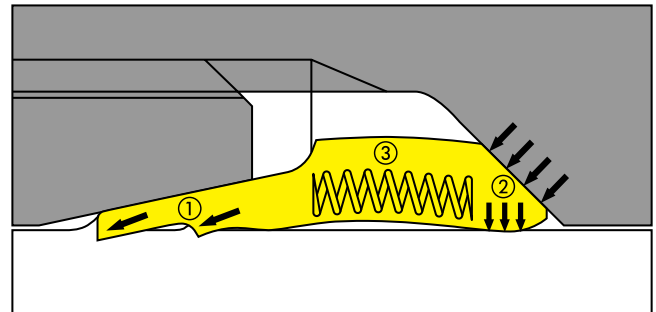

The 3 vital effects of Progressive-Ring assembly: sealing (1), tube clamping (2), spring effect (3).

At assembly of the EO progressive ring fitting, three essential functions are achieved:

① Tube bite

The tube bite guarantees the leak free sealing and ensures the necessary holding power for high operating pressures. After assembly, a collar of cut tube material in front of the cutting edge is the visible control for the proper function of the connection.

② Tube clamping

The rear section of the progressive ring is designed for clamping the tube firmly. This ensures that service vibration loading is not present in the tube bite area.

③ Spring effect

Towards the end of assembly, the special EO progressive ring design, material and heat treatment allow a defined elastic deformation of the ferrule. This spring effect compensates subsidences of tube bite and threads, thus ensuring long term leakfree performance without retightening.

EO-DUR stainless steel products with silver plated threads

All threads of the EO-DUR stainless steel nuts are surface treated to reduce the tightening-torques by 40 % compared to non treated products. The treatment also avoids galling of the threads. The nuts bigger than size 12S/15L are delivered with silver plated threads, all smaller sizes are treated with a special wax.

The EO-DUR Suparcased SPH cutting ring

On the basis of the proven progressive ring design, the suparcased stainless steel bite-type ring has been developed especially for aggressive internal and external media. The special geometry and thermochemical hardening process guarantee a permanently leak-proof and corrosion-resistant connection under extreme conditions. Typical applications are in the food, chemical and medical industries as well as in process engineering.

Common features, advantages and benefits of the EO Bite type system

- **Field assembly** – EO fittings can be assembled virtually anywhere with just a couple of wrenches. For stainless steel tube simple presetting tools are available. No additional equipment or machine is required.
- **Low cost assembly** – Using an EOMAT machine is the most economic method to preassemble EO rings onto tube ends. Whereas the actual preassembly process only takes some 1.4 seconds on the EOMAT III/A, the total “floor-to-floor” time averages around 15 seconds.
- **3 series** – Very Light (LL), Light (L) and Heavy (S) series can be individually selected. For each application there is a solution for best flow rate, sufficient pressure resistance, smallest envelope size, low assembly force and minimum fitting cost.
- **Available sizes** – Most EO fittings are available in 25 sizes from 4 to 42 mm tube OD. Additional reducers allow optimum dimensioning of each individual fluid line. This saves space and material costs.
- **Tube wall** – EO fittings are suitable for use with light wall, medium wall, heavy wall, and extra heavy wall tubing. (Light wall tube may require support sleeve VH.)
- **Tube material** – EO-bite type fittings can be used with most tube materials, such as high and low-grade steel or stainless steel, copper, aluminium or CuNiFe. Even plastic tubes such as nylon, polyurethane, PVC or PTFE can be easily connected by using additional support sleeves E.
- **Visible bite** – The critical ferrule to tube front bite is clearly visible to tube fitters & inspectors. The presence of the recommended bite virtually eliminates any risk of catastrophic blow-off. This is a very important safety feature.
- **Reduced torque** – All nuts of EO-fittings are coated with a highly effective lubricant. Reduced assembly effort help to prevent underassembly which is the most common reason for bite type fitting failure.
- **Sealing capability** – EO fittings have demonstrated a remarkable ability to remain leak free under various service conditions ranging from sealing high vacuum and small molecule gases to high pressure hydraulic fluids.
- **Distributed stresses** – Stresses due to flexural loading in service are distributed at several points in the joint, thus stress concentration in the bite is minimised.
- **Vibration control** – The rear bevel of the ferrule firmly grips tubing, thus dampening the effects of system vibration in the joint.
- **Envelope size** – EO fittings are comparatively small and compact, making it a suitable selection for tube connections in limited or tight spaces.
- **Temperature rating** – EO fittings are suitable for sub zero through elevated temperature applications. Service temperature rating is limited by the material chosen.



Top to bottom: EO Heavy (S), Light (L) and Very Light (LL) series:
Best choice for each individual application
(Illustration: Straight union 6 mm tube OD)



Function of fittings

- **Compatibility** – Since EO fittings can be manufactured from a wide range of metals, compatibility factor with various fluids and atmospheric conditions is extensive.
- **Manufacture** – EO fittings are manufactured under tight quality controls which ensures that the product routinely satisfies or surpasses the requirements of the pertinent military and industrial standards. All manufacturing locations are ISO 9001 certified.
- **Silver plated nuts** – Stainless steel tube nuts are pre-lubricated with silver plated threads (size 15L-42L, 12S-38S). The threads of smaller sized stainless steel nuts are waxed. Thread galling is eliminated and assembly torque is reduced by as much as 40 percent. The EODUR treatment increases the speed and efficiency of stainless steel fitting assembly.
- **Tube length determination** – Exact tube length and bending can easily be checked by just trying out before assembly. This makes on-site piping very efficient.
- **Broad range of configurations** – EO fittings are available in more than 50 configurations. Especially for orientable fittings there is a wide variety of banjos, adjustable elbows or swivel combinations that allow an optimum solution for each application.
- **Functional fittings** – A variety of rotary fittings, non-return valves, Shut-off valves and test point connectors are available with the original EO-joint. This greatly reduces assembly time and cost of additional fittings and also eliminates possible leak paths.
- **True metric design** – EO fittings are designed to metric standards. All threads, hexagons, bores and other dimensions are purely metric.
- **No restrictions** – All bores of each fitting fit the inner diameter of the matching tube. LL, L and S-Series fittings are designed for best flow rate with thin, medium and heavy wall tube. Therefore, best performance without excessive noise or heat generation is always guaranteed.
- **World wide popularity** – The bite type fitting has worldwide acceptance. Most European, Asian, African and South American industry standards are purely metric. But also in Australia and Northern America DIN bite type fittings are gaining acceptance due to the metrification and end user specifications. Many machine operators prefer fittings that can be assembled without any additional equipment.

EO2-Plus



Introduction

As a part of Parker Ermeto's New Generation fittings, the Dry Technology EO-2 Plus Concept proven worldwide has been further developed. EO2-Plus means maximum pressure capability, as well as a new chromium⁶-free surface with significantly higher corrosion resistance, and greatly reduced tightening torques for larger sized fittings.

The common feature of all EO2-Plus fittings is elastomeric seals on all joints. These are also now available in FKM (e.g. Viton[®]) for applications with higher temperatures or aggressive media. This assures leak free operation without retightening – even under extreme working conditions. The easy handling, time and cost saving features, and many assembly advantages of the unique EO2-Plus functional nuts have made EO2-Plus fittings increasingly popular.



EO-2: Safe dry – clean – leakfree

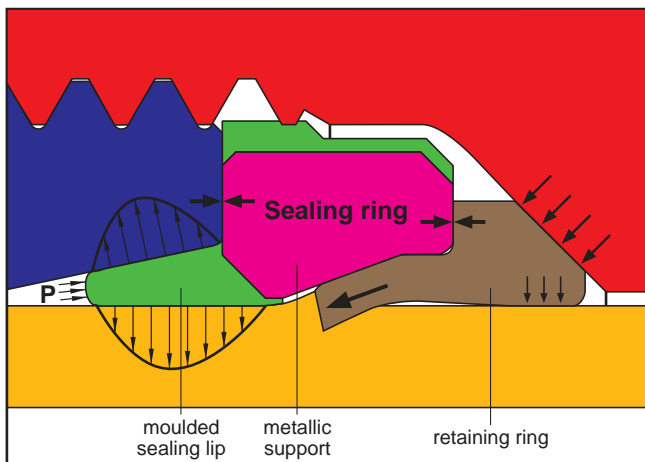

The metallic support of the sealing ring acts just like an integrated pre-assembly tool.

EO2-Plus is designed for metric tube and based on German Standards DIN 3861 and DIN 2353, which today are represented by the international standard ISO 8434-1. EO2-Plus is available in "L"- and "S"-Series.



The new chromium⁶-free EO2-Plus Functional Nut: also with FKM sealing ring

Features, advantages and benefits of EO2-Plus fittings

Naturally all advantages of the proven EO-2 soft sealed technology are also present in EO2-Plus, however, the new EO2-Plus Generation additionally offers the following:

- **Plus: Highest corrosion resistance** – The corrosion resistance is increased by 400% to more than 500 hrs. to white rust.
- **Plus: Increased pressure** – Due to the application of even better materials combined with the special processing of individual components, EO2-Plus can be used in applications of up to 800 bar (S series) and 500 bar (L series). EO2-Plus considerably exceeds the DIN/ISO requirements and guarantees a 4-fold design factor. Thanks to the higher pressure levels, less expensive "L" series fittings can now be used instead of the heavier "S" series, which also is of benefit in limited or tight space applications.
- **Plus: EO-LUB** – Due to the special treatment of the larger sized nuts by the EO-LUB procedure (25S/28L and larger), the tightening torques of EO2-Plus fittings have been reduced by 25%. This makes assembly easier and prevents underassembly, the most common reason for tube fitting failure.
- **Plus: Chromium⁶-free** – Due to its chromium⁶-free treated surface, Parker Ermeto now meets the requirements to be expected in the automotive industry and the expected requirements issued by the European

Function of fittings

Parliament to eliminate the use of materials and surfaces containing chromium⁶. The removal of chromium⁶ reflects Parker's ongoing commitment to an environmentally clean and safe production process.

- **Plus: Worldwide availability** – EO2-Plus is available worldwide and meets the requirements of the applicable standards for 24° cutting ring fittings.

Function of the EO2-Plus fitting system

Elastomeric sealing

The elastomeric seal assures a hermetically sealed tube joint. It is located in between the inner cone of the fitting body and the tube surface, thus blocking the only possible leak path. Due to its large cross-section, the seal effectively compensates for all manufacturing tolerances on tube and fitting cone.

The sealing effect is pressure supported which makes the EO2-Plus fitting suitable for high pressure applications. The static compression also eliminates air-ingress into the fluid system at underpressure conditions.

Elastomerically sealed EO2-Plus fittings do not require any retightening even in heavy duty applications. Seal extrusion is prevented by proper housing without gaps or dead volume. The sealing lip is bonded to a metallic support ring.



Before tightening the nut

Assembly “to block”

The retaining ring bites into the tube in accordance to the proven bite ring principle. The support ring reduces the danger of over- or underassembly by a special EO2-Plus design feature: Before assembly there is a gap in between the flat surfaces of the retaining ring and the metallic support ring of the seal. As soon as the retaining ring has



After tightening the nut

Closing the gap at the end of assembly provides a clear “Hit-Home-Feel”.

reached the proper bite depth, the gap closes, resulting in a sharp increase of assembly torque. This results in uniform and reliable fitting assemblies. The assembly result can easily be inspected by just checking if the gap is closed.

The separation of sealing and fixing function to two separate elements finally allows a more effective solution of the over- and undertightening problems of bite type fittings than increasing the number of cutting edges.

Integrated assembly tool

The metallic support ring of the seal is made of a special design, material and heat-treatment to act as a assembly tool. This makes sure that the retaining ring securely cuts into the tube surface without damaging the sensitive inner cone of the fitting body.

This unique feature of EO2-Plus fittings even allows direct assembly of stainless steel tube without any additional pre-assembly process. Of course, an EOMAT machine can be used to allow easy assembly of large dimension tube and drastically save total assembly time, effort and costs.

The integrated assembly tool of EO2-Plus fittings even helps to save further costs and trouble when using an EOMAT-type presetting machine:

As the presetting cone is only in contact with the elastomeric sealing lip, it cannot be worn out or damaged even after thousands of assemblies. This does not only save replacement costs but also avoids leakage problems caused by worn presetting tools.

The functional nut

The unique functional nut simplifies handling of fitting components and helps to minimise storage and procure-



The unique functional nut allows easy handling and quick assembly.

ment costs. The sealing and retaining rings are combined as a pair and are inserted into the internal thread of the nut in such a manner that they cannot fall out, so that these three parts form one functional element.

Individual components such as seals or retaining rings cannot be forgotten, confused or assembled in the wrong orientation. Time and cost is saved, arranging the components to make up individual joints.

The functional nuts match all EO tube fitting joints. After assembly and disassembly, the sealing ring can be replaced individually without cutting off the tube end.

Common features, advantages and benefits of the EO-2 and EO2-Plus fitting system

In addition to the general advantages of the EO tube fitting system, the unique EO2-Plus fitting features even more specific benefits:

- **Sealing capability** – An elastomeric seal forms the primary sealing element, thus assuring leakfree sealing. Even low-viscosity media such as water or gas are hermetically sealed. Hydraulic systems therefore do not “sweat” at fittings.
- **Durability** – The elastomeric seal does not require any retightening even after years of operation under extreme working conditions.
- **Bite control** – The ideal bite depth is controlled by the fitting design rather than by the fitters force. Closing the gap at the end of manual assembly, the fitter gets clear signal that setting is completed and the joint is ready for inspection.
- **Functional nut** – Individual components such as the retaining ring or seal cannot be lost, forgotten, confused or assembled in the wrong orientation. This dramatically saves assembly cost and helps to avoid dangerous assembly errors.

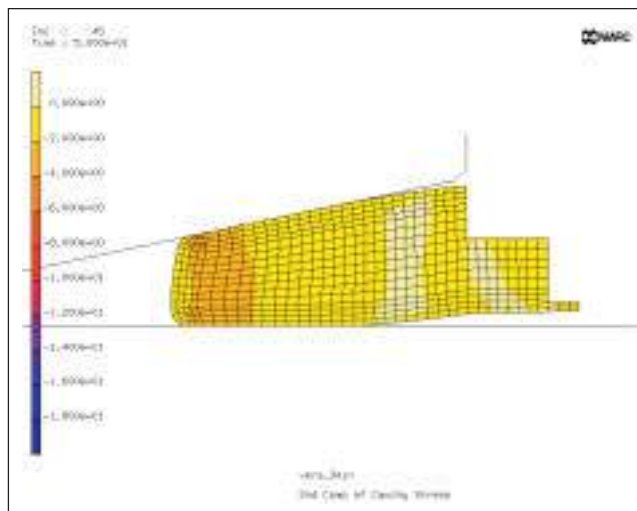

FEM (Finite Element Method) has been used to optimize the seal design (Picture: FES, Raiffeisenstr. 10a, D-74343 Sachsenheim).

- **Assembly cost** – With less than 10 seconds cycle time on the EOMAT III/A (actual presetting process: 1.4 seconds) the cost of presetting EO2-Plus is extremely low.
- **Integrated preassembly tool** – Each EO2-Plus functional nut comes assembled with an integrated assembly tool that makes sure that the retaining ring securely cuts into the tube surface without damaging the sensitive inner cone of the fitting body. This greatly reduces the danger of tube blow-off, even when using stainless steel tube.
- **Reliable reproducibility** – When EOMAT machines are used for cost-efficient presetting, the preassembly tools do not wear out as they are only in contact with the rubber seal. This avoids leaks and dangerous blow-off which can result when traditional bite-type fittings are assembled using worn presetting tools.
- **Final assembly** – From the wrench-tight position of the preset EO2-Plus joint, one short pull on the wrench (approx. 1/6 to 1/4 turn) gives the assembly a quick high rise to required torque. EO2-Plus fittings have a solid “Hit-home-feel” and excellent over-torque resistance.
- **Visible inspection** – There is no doubt if an EO2-Plus functional nut has been preset correctly or not. Inspection is as simple as checking if the gap between retaining ring and sealing ring is completely closed. The tube end does not have to be disassembled out of the fitting for bite inspection.
- **No phantom leaks** – Lubrication is not mandatory for the assembly of steel EO2-Plus fittings. The machine operator will not be irritated about lubricant coming out of the fittings once the hydraulic system gets hot.

Function of fittings

- **Reusability/Remakeability** – EO2-Plus fittings can be disassembled and reassembled many times. There is no wear or widening of the vulnerable inner cone. Damaged seals can easily be replaced. All spare DOZ-seals are marked by size-code (e.g.: 12–L).
- **On-Site-Maintenance** – For the maintenance and replacement of EO2-Plus fittings a set of wrenches is sufficient. Additional in – line – components, such as test points (GMA), ball valves (KH) or Tee-fittings can be added to an existing assembly within minutes.
- **Interchangeability** – The EO2-Plus functional nut can be used for the whole variety of the broad range of more than 50 configurations in some 25 sizes of standard EO LL, L and S-series fittings. Changeover from progressive ring or weld nipple is easy by the simple use of EO2-Plus functional nuts.
- **Reliability** – Millions of EO2-Plus fittings are working trouble free in applications like: Mobile Construction equipment, stationary machine tools, hydraulic pres-

ses, plastic injection moulding machines, shipbuilding, offshore exploration, submarines, railway trains and military equipment. Leakage does not occur on EO2-Plus pipework.

- **Trouble-free** – Regular bite type fittings allow typical assembly-errors such as: confusion of bite type ring material and size. Also, the use of worn-out pre-assembly tool may result in fitting failure. The clever EO2-Plus design does not allow most of these mistakes without making the assembly process more complicated.
- **Popularity** – EO2-Plus fittings are as easy to assemble as traditional bite type fittings, but they eliminate most of their typical assembly problems. EO2-Plus fittings are therefore appreciated by an increasing number of original equipment manufactures. EO2-Plus also has become the fitting of choice of end-users that appreciate the leakfree performance, the easy maintenance and the global availability of the metric soft-seal bite type system.

Suitable FM-type

	Steel tube	Stainless tube	Plastic tube
Steel fittings body (EO2-Plus)	FM...CF	FM...SSA	FM...CF
Stainless steel fitting body (EO-2)	—	FM...71	FM...71



EO-2 fittings are used for heavy-duty applications, such as construction equipment or plastic injection molding.



Every day millions of EO-2 fittings perform absolutely trouble-free.

EO2-FORM



Introduction

EO2-FORM is the new high pressure formed tube Generation of the Tube Fittings Division Europe. As with EO2-Plus, it is designed in to eliminate leakage in all fluid systems, by using elastomeric sealing systems.

The common feature of all EO2-FORM connections are the EO2 seal elements (Dry Technology) as well as the new cold forming process, that gives extreme rigidity and low tightening torques. The seals are now also available in FKM (e.g. Viton®) for applications with higher temperatures or aggressive media.

Through EO2-FORM, elastomeric sealing technology is made available even where bite-type connectors are not popular, like in hydraulic presses, cranes, lifts or ship canal locks. Compared to welding or brazing, the EO2-FORM process is faster and easier. It does not require special tube treatment, heating or chemicals.

EO2-FORM is designed for metric tube and fully interchangeable to the complete Ermeto Original product range according to ISO 8434-1 / DIN 2353. EO2-FORM is available in "L"- and "S"-Series.

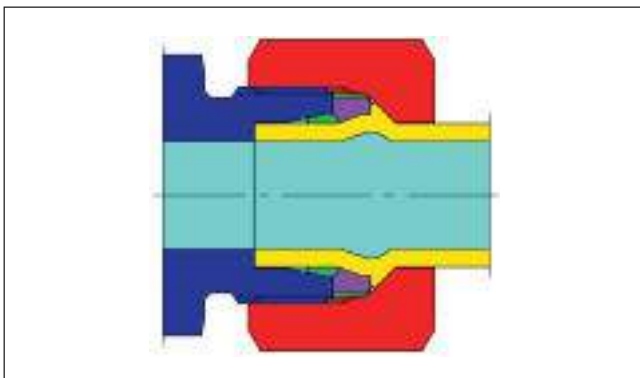

The new EO2-FORM connection:
Extreme rigidity and low tightening torques



The EO2-FORM F2 machine

Function of EO2-FORM

EO-2/EO2-FORM system

EO2-FORM is not a stand-alone product. It has been developed as an extension of the proven EO2-Plus system product range. All EO2-FORM components like nuts, seals and fitting bodies come from the EO2-Plus program. The only investment needed is the forming machine, which pays off quickly as it reduces assembly time and effort. Assembly characteristics of EO2-FORM are similar to

The EO2-FORM process



Tube end is prepared and equipped with EO nut



Tube is inserted into the tools until it firmly touches the stop at the end



After starting the process, the dies clamp the tube and the forming pin starts to move forward



While moving, the pin is continuously forming the tube wall and compressing the material



The tool shape defines the outer contour of the formed tube wall



The inner contour also gets slightly deformed but remains smooth and unrestricted for good flow characteristics



As soon as the moving pin touches the clamping jaws, the forming process is completed



The tube end is released and ready for attaching the EO-2 seal



Installation is made in the fitting body

EO2-Plus too. This allows the customer to use both products for his hydraulic pipework without increasing stock or confusing workflow engineers with new components.

Elastomeric sealing

For EO2-FORM, the same sealing ring “DOZ” is used as for EO2-Plus. The high volume elastomeric seal assures a hermetically sealed tube joint. It is located in between the inner cone of the fitting body and the tube surface, thus blocking the only possible leak path. Due to its large cross section, the seal effectively compensates for all manufacturing tolerances between the tube and fitting cone.

The sealing effect is pressure supported which makes the EO2-FORM fitting ideal for high pressure applications. The static compression also eliminates air-ingress into the fluid system in vacuum conditions.

Elastomerically sealed EO2-FORM fittings do not require any retightening even in heavy-duty applications. Seal extrusion is prevented by proper housing without gaps or dead volume areas. The sealing lip is bonded to a metallic support ring.

Cold-formed tube

The cold-forming of the tube is carried out by the EO2-FORM machine. Machine operation and tool setup are optimised for short cycle times, which makes the process easy and fast. The tube is connected when the sealing ring is fixed and the nut is tightened.

The working contact area of the EO2-FORM connection is the flat front surface of the metallic support ring which is made of heat-treated, high-strength steel. This provides superior mechanical strength without settling, loosening or need for re-tightening.



Before tightening the nut



After tightening the nut

Features, advantages and benefits of the EO2-FORM fitting system

- **System solution** – No additional items need to be purchased or stocked on top of the existing EO-2 product range. Assembly characteristics of EO-2 FORM are similar to EO2-Plus, too. Therefore, EO2-FORM can be introduced with minimum effort.
- **Flexible concept** – The product family of EO-2 and EO2-FORM allows the application of the optimum product within a complex hydraulic system or a whole manufacturing facility. EO2-FORM can be used for heavy duty applications like presses, EO-2 is ideal for general hydraulic and pneumatic pipework. This allows maximum total system performance with minimum component, assembly and stocking cost.
- **No risk** – EO2-FORM technology is based on the proven EO-2 technology. All components and the assembly technology are approved. The customer does not have to test a new system.
- **Highest pressure performance** – Due to the application of even better materials combined with the special processing of individual components, EO2-FORM can be used in applications of up to 800 bar (S series) and 500 bar (L series). EO2-FORM considerably exceeds the DIN/ISO requirements and guarantees a 4-fold design factor. Thanks to the higher pressure levels, less expensive “L” series fittings can now be used instead of the heavier “S” series, which also is a benefit in limited or tight space applications.
- **Sealing capability** – The high volume elastomeric seal forms the primary sealing element, thus assuring leak-free sealing. Even low-viscosity media such as water or gas are hermetically sealed. Hydraulic systems therefore do not “sweat” at the fitting joints.
- **No phantom leaks** – Lubrication is not mandatory for the assembly of steel EO weld nipples. The machine operator will not be irritated about lubricant coming out of the fittings once the hydraulic system gets hot.
- **Universal** – The EO2-FORM machine can cold-form all common steel tubes used in hydraulic systems (the EO2-FORM process also allows the use of stainless steel and exotic materials such as CuNiFe; please ask for separate catalogue). EO2-FORM tools cover metric tube from 6 to 42 mm OD. Thin wall tube of 1 mm wall thickness can be formed, too.
- **Superior vibration resistance** – The new EO2-FORM process achieves a smooth structural transformation of the tube wall allowing superior vibration resistance.
- **Durability** – The elastomeric seal does not require any re-tightening even after years of operation under extreme working conditions.
- **Efficient** – Compared to welding or brazing, EO2-FORM is much less time consuming. Special tube preparation and finishing are not necessary. Forming uses only a fraction of the energy needed for brazing or welding.
- **Quality** – Tube clamping and tooling are fully automated. Therefore, high and consistent quality is achieved without manual adjustment.
- **Noise reduction** – Compared to other forming methods, the EO2-FORM process results in a smooth inner contour of the tube that does not allow the accumulation of air, dirt or other sources of trouble. Less pressure drop, heat and noise is created.
- **Re-usability** – EO2-FORM connections can be disassembled and reassembled many times. There is no wear or widening of the vulnerable fitting inner cone.
- **Approved** – Both, EO-2 high pressure tube fittings and the EO2-FORM process are tested and approved by independent organisations such as Germanischer Lloyd and Det Norske Veritas (DNV).
- **Small bending radii** – The compact clamping device and special dies are suitable for forming short tube ends.
- **Clean** – The EO2-FORM process is environmentally clean and safe. As no heat is used, hazards from chemicals, fumes or heat do not occur.

EO weld nipple



The leakfree performance of EO Weld nipples is assured by an O-ring seal.

Introduction

EO-weld nipples have been introduced to the market in the late 60's. The simple bite ferrules off the 60's were designed for hydraulic applications of pre-war time and did not match growing market demands on high pressure performance, impulse and vibration resistance. Also, the single bite ferrule was easy to over- or undertighten. Most assembly workshops could not afford assembly machines so that large size fittings often failed due to underassembly. Still, European customers preferred to stay with the established EO fitting body range, as it provides unbeaten advantages like: full metric system, repair possible with just two wrenches and 3 series of different design and pressure performance.

EO weld nipples provide all these benefits based on replacing the bite type ring by a welded connection. Today, modern solutions like EO2-FORM and O-Lok® provide the same performance without the effort of welding.

Applications

EO weld nipples are used for applications where the advantages of the EO program are appreciated and the rigidity of a solid weld connection is required. EO weld nipples are traditionally used for heavy duty applications such as hydraulic presses, mining, steel mills and shipbuilding.

Today, many users of weld nipples are switching to modern "Dry Technology" fittings using reliable assembly methods such as O-Lok®/Parflange® or EO-2/EOMAT.

Function of the EO weld nipple

The wide EO fitting range allows welded tube connections. Therefore, the EO weld nipple has to be welded onto the tube end.

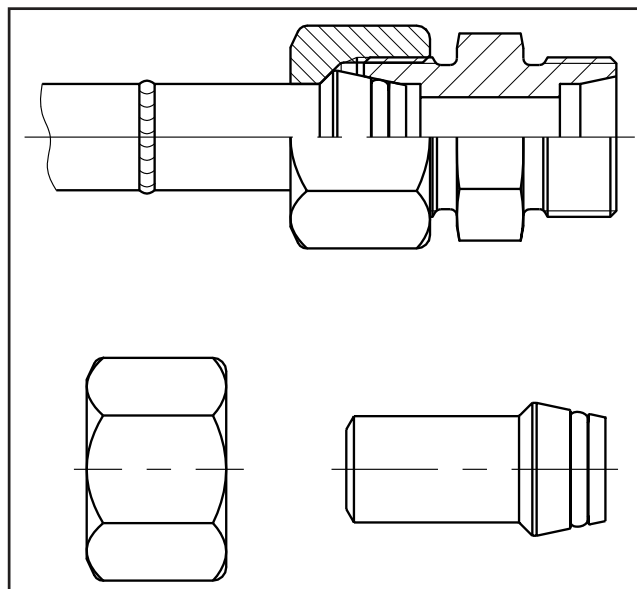

EO-Weld Nipples match to all fittings of the wide EO-range.

Using the standard EO nut, this weld nipple can then be connected to the tube joint of any EO tube fitting.

EO weld nipples are available for L and S-series tubes of 6–38/42 mm diameter. A broad range of weld nipple fittings including reducers or elbows covers most applications.

The use of EO weld nipples allows remakeable pipe systems based on rigid weld connections.

Features, advantages and benefits of the EO weld nipple

EO weld nipples feature most advantages of the attractive EO fitting program. The specific benefits of the EO weld nipple program are:

- **Low quality tube** – Unlike bite-type or flared fittings, dimensional tolerances and rough tube surface are not very critical. Therefore weld nipples are suitable for countries where only poor quality tube is available.
- **Sealing capability** – An elastomeric seal forms the primary sealing element, thus assuring leakfree sealing. Even low-viscosity media such as water or gas are hermetically sealed. Hydraulic systems therefore do not "sweat" at fittings.
- **Durability** – The O-ring seal is assembled with a high initial compression. It does not require any retightening

even after years of operation under extreme working conditions.

- **Failure mode** – Unlike bite type fittings there is little danger of tube blow off if the fitting is not properly tightened. A loose joint shows excessive leakage before total failure.
- **Reusability/Remakeability** – EO weld nipples can be disassembled and reassembled many times. There is no wear or widening up of vulnerable inner fitting cone. Damaged O-rings can easily be replaced.
- **Smooth edge** – Under extreme working conditions, weld nipples are most likely to crack at the dimensional step just under the nut. In an additional rolling process this critical edge is smoothed for increased vibration strength.
- **Stress-free** – By welding, little deviations on tube cutting or bending can be compensated. Tension-free pipework is not likely to break even under extreme working conditions.
- **Welding process** – EO weld nipples are designed to be used for most popular welding processes.

Introduction to O-Lok® Plus



The O-Lok® fitting was developed by Parker Tube Fittings Division in the USA in the early 1980's. This product has proven to be extremely effective in eliminating leaks at the higher pressures found in today's hydraulic systems.

The O-Lok® Plus fitting is an O-ring face seal (O.R.F.S.) type fitting that consists of a nut, a body, an O-ring and a sleeve. As shown in Fig. 1 the tube is flanged to 90° using the patented Parflange® system (or the tube may be brazed instead to a braze-type sleeve). When the fitting is assembled, it compresses an O-Ring in the precision-machined groove in the fitting body to form a leak-tight seal.

O-Lok® Plus fittings are suitable for a wide range of tube wall thickness and are also readily adaptable to inch or metric tubing and hose connections.



Before tightening the nut



After tightening the nut

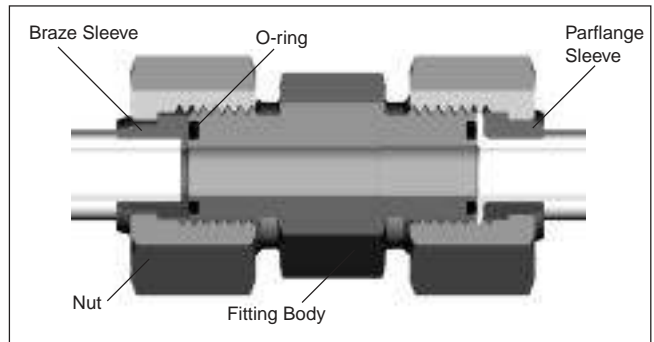

Fig. 1 – O-Lok Union cutaway with flanged and brazed assemblies

O-Lok® Plus

The last twenty years of experience supplying O-Lok® Plus have been well used in terms of listening to customer needs and refining design and material details to achieve the optimum mix of headline performance and a long trouble-free service life. After extensive product testing, it has been recognised that Parker O-Lok® Plus fittings can be uprated to higher performance levels. The O-Lok® Plus fitting system is characterised by the words.

'Durability' and 'leakfree performance'.

- **Pressure Plus** – Larger fitting sizes nominal pressure increased
 - 20 from 280 to 420 bar*
 - 24 from 280 to 350 bar*

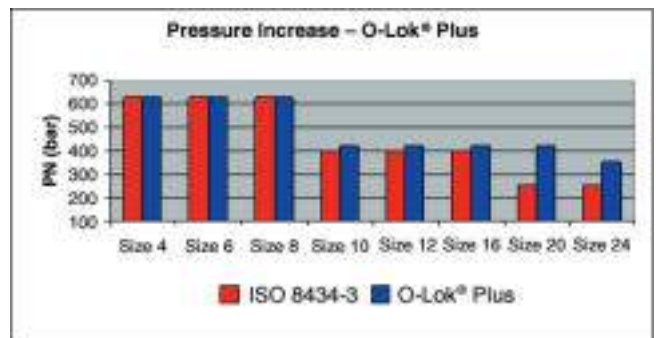

- **Flange Seal Plus** – A development of the patented Parflange® system, the Flange Seal gives a cold-formed tube end connection to eliminate the need for costly brazing in Hose – Tube and Tube – Tube connections.
- **Plating Plus** – Resistance to white rust corrosion increased and exceeds international standards.

*For detailed pressure ratings see chapter C.

- **Cleanliness Plus** – Contamination is the biggest source of early component failure in hydraulic systems. Parker O-Lok® Plus fittings meet all requirements from the factory to the point of use – backed up by individual bagging.
- **CORG Plus** – All Parker O-Lok® Plus fittings are manufactured with Captive O-Ring Grooves as standard.
- **Range Plus** – Parker offers the widest range of catalogue standard materials, seal combinations, styles and sizes in the industry. Only Parker has all this.

Applications

The original development of the O-Lok® Plus fitting was heavily influenced to meet the needs of international mobile equipment companies, mining, site clearance, agricultural and other heavy duty equipment. Today, the O-Lok® Plus fitting is becoming an industry standard hydraulic fitting system for rugged duty equipment mounted on tracks or wheels. Equipment in these fields of application endure some of the highest levels of use, sometimes round the clock operation, in tough environments with extremes of temperature and mechanical stress. The simple, but effective design of the O-Lok® Plus connection when used with the Parflange® tube preparation technology mean that long term 'fit and forget' performance is ensured, despite the physical conditions.

Simple, low torque assembly, no tube entry breakaway feature, 2"/50 mm max. tube size, and the ease of use with inch or metric tubing also make O-Lok® Plus eminently suitable for general hydraulic applications in hydraulic presses, injection moulding equipment, shipbuilding, machine tools and a range of other areas. Anywhere in fact where a high quality leak-free tube or hose connection is needed.

Function of O-Lok® Plus fittings

The O-Lok® Plus fitting consists of four main components: a body, a sleeve, an O-ring and a nut.

The O-Lok® Plus fitting body

There are over 40 different body configurations to choose from for specific applications. The body face has a groove, which contains a high durometer O-ring that is held captive during installation. In addition, the O-Lok® Plus fitting body shapes are all forged for added strength and longer service life.

Straight fittings are made from cold drawn barstock. The cold drawing process ensures consistent dimensional tolerances, improved strength and consistent surface finish.



Fig 1 – Captive O-ring Groove (CORG) cutaway

CORG Groove

O-Lok® Plus fittings are manufactured with a Captive O-ring Groove (CORG) design for prevention of O-ring fall out prior to final assembly. The international standards for ORFS fittings contain two versions of the O-ring groove. The original design had straight sides and under certain conditions of tolerance between the O-ring and the groove, it was possible for the O-ring to be dislodged. As a further refinement of the O-Lok® Plus fitting, Parker introduced the CORG groove as standard production in all its plants in 1998.

O-ring

From the design of the system, the O-ring compression gives excellent sealing characteristics from low pressure, low temperature circumstances found in winter during machine storage, to full pressure, high temperature cycles.

The O-Lok® Plus fitting nut

Smaller size O-Lok® Plus fitting nuts are cold-formed to provide a more tightly packed grain structure, resulting in a much stronger component. Larger size nuts are made of warm-forged steel-blanks.

The O-Lok® Plus Parflange® sleeve

The preferred method of making an O-Lok® Plus tube connection is by using the Parker Parflange® process to create the 90° flange on the tube end. A flange sleeve is used to support the flange and the tube, and provides the contact shoulder for the nut. After the Parflange® process, the sleeve is permanently fixed on the end of the tube reinforcing the joint.

The O-Lok® Plus connection using the Parflange® method can be made with either metric or inch tubing by choosing the appropriate sleeves and tooling.

Parflange® sleeves from Parker are manufactured to exacting tolerances and geometry to work with the Par-

Function of fittings

flange[®] machine and tooling, producing the robust, reinforced tube end connection. Failure to use the correct components can result in premature joint failure in the final application.

The O-Lok[®] Plus braze sleeve

The braze sleeve provides the mating surface between the tube and the fitting body. Secondly, the braze sleeve, as the name implies, is attached to the tube through silver brazing. The braze provides holding power as well as a method to seal the joint. It also has a flat and smooth contact shoulder for the nut to connect the tube to the fitting body.

O-Lok[®] Plus braze sleeves are manufactured to exacting dimensions. Tightly toleranced dimensions are required to prevent binding in the nut when torqued, to provide a flat and smooth sealing surface against the O-ring, and to give the appropriate clearance for silver brazing to the tube.

The O-Lok[®] Plus connection can be made with either metric or inch tubing by choosing the appropriate braze sleeve.

The O-Lok[®] Plus reducing braze sleeves

O-Lok[®] Plus braze sleeves are manufactured in both even and reducing sizes. The reducing sleeves make it easy to adapt a larger face seal fitting to a smaller tube connection.

O-Lok[®] Plus fitting function

The O-Lok[®] Plus fitting body face contains a high durometer O-ring that is held captive in a precision machined groove. As the nut is tightened onto the fitting body, the O-ring is compressed between the body and flat face of the tube flange or braze sleeve to form a tight, positive seal (see Fig. 1).

As the two faces come in contact, further tightening of the nut produces a sharp rise in assembly torque. A solid pull of the wrench at this point, to the recommended assembly torque, completes the assembly.

The sharp torque rise gives a “solid feel” at assembly, and minimises the possibility of over tightening.

Because the sealing surfaces are flat and perpendicular to the assembly forces, they remain virtually free of distortion during assembly, giving O-Lok[®] Plus fittings virtually unlimited remakeability. The O-ring should be inspected at each disassembly and replaced when necessary.

The Flange Seal System

Parker's new Flange Seal Fitting System, provides an efficient, fast, and economical method to connect a tube line

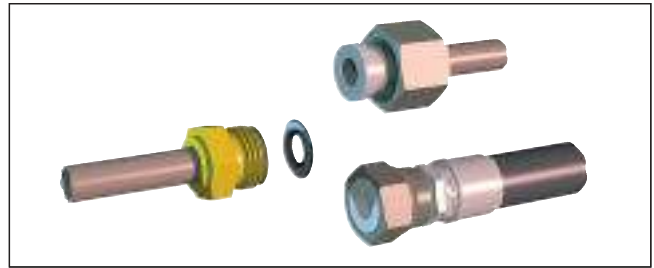

Flange-Seal fitting system

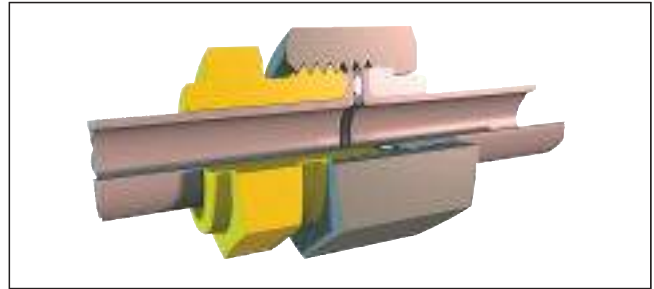

Dry Technology connection

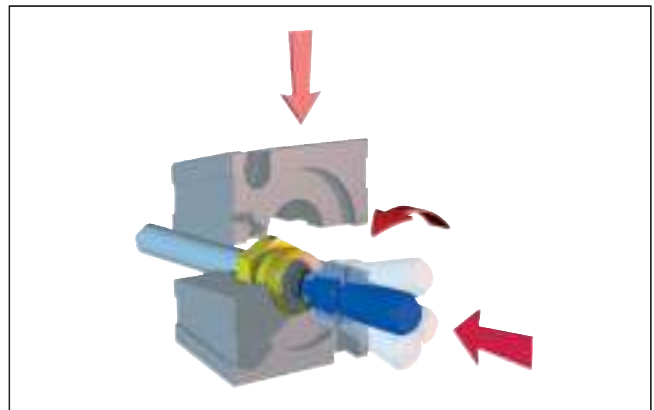

Orbital flanging

to a hose assembly, or another tube line. It replaces the need for conventional braze-on male ORFS ends by a modern tube preparation method. By eliminating the brazing operation, this creates several advantages – flexibility of batch sizes, and production location, safer finished result, fewer process stages, all resulting in cost reduction opportunities.

The Flange Seal System is a development of the patented and proven Parflange[®] process to create a 90° flange on the tube end. A custom-designed bonded elastomeric seal is positioned between the Flange Seal tube line and the mating hose/tube assembly. The seal is designed with rubber tabs on the outside diameter, allowing it to be securely positioned within the tube nut or hose end swivel prior to assembly. When assembled by tightening the nut, the seal is compressed between the two flat surfaces, providing a leak-tight connection.

Flange Seal features, advantages and benefits

- Eliminates potential leak path and reduces costs
- Reduced assembly costs
- Leak free connection, lower assembly and rework costs
- Assures reliable sealing
- Reduced tube preparation cost
- Flexible, reduced batch sizes, lower stock costs
- Safer process
- Reduced cost and complexity
- Better asset utilisation

For full details see brochure 4353/UK.

O-Lok Plus: Features, advantages and benefits

- **Leak-free** – The O-Lok® Plus fitting system provides a leak-free, 'fit and forget' performance due to the elastomeric sealing design. O-Lok® Plus fittings form part of Tube Fitting Division's 'Dry Technology' family of products.
- **Pressure rating** – With pressure ratings up to 630 bar, the O-Lok® Plus system meets the requirements of today's high pressure hydraulic systems.
- **Heavy duty capability** – In addition to high pressure resistance, O-Lok® Plus fittings have been tested and proven in the heaviest duty applications known against the effects of shock and vibration, and are becoming the 'fitting of choice' in construction equipment.
- **Corrosion resistance** – O-Lok® Plus fittings achieve corrosion resistance, far above industry standards.
- **Flexibility** – O-Lok® Plus is available in steel, stainless steel and brass (on request). By selecting body materials and changing industry standard sized O-rings, the O-Lok® Plus system can adapt to the extremes of temperatures and specified fluid media.
- **Hose or tube connections** – O-Lok® Plus fittings can be used equally well as a tube fitting or a high performance hose adapter.
- **Ease of tube preparation** – The patented Parflange® tube preparation system flanges the tube end to 90 degrees to give a high quality seal face against the fitting O-ring seal.
- **Ease of tube preparation** – the new Flange Seal system allows the elimination of costly brazing for hose – tube and tube – tube connections.
- **Tube materials** – O-Lok® Plus fittings can be used with most tube materials, such as high and low-grade steel or stainless steel, copper and aluminium.
- **Metric or inch tube compatibility** – Just by changing the tube sleeve, either inch or metric O.D. tube can be used. Customer tube specifications can be followed without changing the complete fitting system. O-Lok® Plus is one of the few designs of tube fitting to allow this.
- **Range of standard sizes** – the O-Lok® Plus system is available in sizes to suit from 6 mm/1/4" to 50 mm/2" tubes, or their equivalent hose sizes. No other manufacturer makes this range as standard.
- **Ease of assembly** – Because the system design requires no component deformation or tube forming during the final assembly, the O-Lok® Plus fitting is exceptionally easy to assemble, requiring lower assembly torque than comparable fittings of similar working pressure.
- **Consistency of assembly** – At final assembly, metallic faces are in direct contact, giving a clear signal to the assembler. After this point, a short sharp pull is all that is needed to complete the joint. This short assembly tightening angle means that fittings are much easier to assemble in areas with poor access or little space.
- **Visible quality check** – Due to the design, quality checking prior to final assembly is simple and therefore reliable.
- **No tube entry** – O-Lok® Plus fittings and the corresponding tube end both have a flat face. This means that tube lines can be more easily installed without 'springing', and during maintenance, it is easier to disassemble hydraulic components without completely stripping the line.
- **Breadth of fitting styles** – O-Lok® Plus is available as standard in over forty basic fitting body styles, making it a flexible system.
- **Worldwide availability** – O-Lok® Plus fittings are available worldwide for the Parker network of sales locations and Certified Distributors, giving back-up wherever it is needed.
- **Standardised** – Parker O-Lok® Plus fittings conform to the relevant international standards (SAE J1453 & ISO8434-3), which means that specification of the fitting system is easy, consistent and low cost compared to writing 'in-house' standards.

Parflange® orbital flaring process and the Flange Seal* system

The Parflange® process

With the Parflange® process, the tube to sleeve attachment is achieved mechanically during an orbital cold forming process with a Parflange® machine. The process progressively flares then flanges the tube. The final dwell action in the cycle ensures that the seal surface produced is smooth and flat, and also eliminates springback effects in the material. This flange provides both the holding power and sealing surface (eliminating the braze joint, and hence, a potential leak path found with brazed sleeve attachment). The only sealing point is between the fitting body and the tube flange face via the high durometer O-ring.

The flanging process is very fast and requires very little cleaning prior to or after flanging. Thus, the process enhances the integrity of the joint and reduces cost.



Parflange 1025

The Parflange® process utilises an orbital cold flow forming process to produce a flat, smooth, rigidly supported 90° sealing surface on the tube end. The process progressively flares then flanges the tube.

*See brochure 4353 for full details.



Parflange 1040

The Parflange® process conforms to the requirements for mechanical tube forming shown in the SAE J1453 standard, and has been specified after extensive testing by the majority of the large mobile equipment manufacturers.

Flanging with Parflange® eliminates the need for welding or brazing of the sleeve to the tube end.

Parflange® advantages over brazing or welding

- **Faster** – 9 to 12 times the speed of comparable induction brazing.
- **Simple tube preparation** – The Parflange® process does not require any special pre- or post-flange cleaning of the tube and sleeve.
- **Safety** – Unlike brazing, the Parflange® process does not require any flux, braze alloy, post braze cleaner or rust inhibitor. An environmentally safe lubricant applied to the flanging pin is the only additive associated with the Parflange®.



Parflange tools

- **Environment** – The Parflange® process is environmentally clean and safe. It does not require open flame or any form of heating. Additionally, there is no emission of hazardous fumes, as is typical with welding and brazing.
- **Energy** – The Parflange® process uses only a fraction of the energy needed for welding or brazing.
- **Corrosion resistance** – The Parflange® process accommodates the use of plated or unplated components (i.e. tube and sleeve). Thus, the high costs of electroplating assemblies after fabrication is eliminated by using pre-plated tube.

The Parflange® process



For O-Lok®, the sleeve is placed into clamping dies first



Tube is inserted into the tools until it firmly touches the stop at the end



After starting the process, the dies clamp the tube and the flanging pin starts the orbital movement and the forward stroke



While moving, the front pin expands the tube wall from the inside



As soon as the flat working surface of the pin contacts the tube end, the flanging process begins



The front surface is continuously rolled and compressed. From the inside, the tube surface is slightly expanded to clamp the sleeve



As soon as the defined flange contour is achieved, the orbital movement stops and the pin withdraws



The tube end is released and can be taken out of the machine



The connection is ready for assembly

Function of fittings

- **Excellent surface quality** – The Parflange® process eliminates the potential leak path present at the braze or weld joint.

The Parflange® process produces a burnished sealing surface, typically much smoother than the 3.1 μm/125 micro-inch Ra surface smoothness requirement of SAE J1453.

Users of Parflange® and Parker's O-Lok® fittings enjoy all the inherent sealing, reliability, time and cost saving benefits, without the many drawbacks which accompany welding or brazing.

Therefore, Parker strongly recommends the Parflange® process for the assembly of Triple-Lok® and O-Lok® connections. Parflange® machines range from desktop 1025 for flexible workshop use to 1040 for economic industrial production.

Features, advantages and benefits of the Parflange® process for Triple-Lok®, O-Lok® and Flange Seal connections

- **Superior sealing performance** – The patented Parflange® process achieves a sealing surface of unique surface quality and mechanical strength.
- **Superior vibration resistance** – Unlike conventional flaring, the Parflange® process results in a rigid connection of the O-Lok® sleeve on the tube-end. Parflange®/

O-Lok® connections perform much better under reversed bending stress conditions.

- **Easy to use** – No programming or adjustments necessary. High quality results are consistently achieved without manual adjustment.
- **Cost saving** – Compared to brazing or welding, orbital flanging is much less time consuming. Special tube preparation and finishing are not necessary. Flanging uses only a fraction of the energy needed for brazing or welding.
- **Clean** – The Parflange® process is environmental clean and safe. As no heat or chemicals are used, hazards from fumes or heat do not occur.
- **Zinc plated tubing** – The Parflange® process allows the use of zinc-plated tubing. The cost for cleaning, post process plating or painting can be saved.
- **Process/Product concept** – Parflange® machines are specially designed to match Parker O-Lok® and Triple-Lok® standards. Machine, tools and products are fine-tuned for reliable performance.
- **Proven technology** – For more than 10 years, hundreds of Parflange® machines have operated worldwide under heavy duty workshop conditions.

Introduction to Triple-Lok® Plus



The concept of flaring tube to provide a seal and holding power to the connection is very old. It's origin goes back to the early days of the automobile. Different types of flared connections including 45° single and double flares, inverted flare, 30° flare, etc., were developed for coolant, fuel, brake and lube systems of the early automobile.

Pioneered by Parker Hannifin, the Triple-Lok® Plus 37° flared fitting evolved as a higher pressure version of the above connections. Its initial use was in the developing hydraulic systems of agriculture and earth moving machinery, automotive transfer lines and other machine tools.

As exports of machinery increased after World War II, the Triple-Lok® Plus fitting gained worldwide use and accept-

ance. Today it is the most widely used fitting in the world. It enjoys conformance approvals by a range of national and international technical and certifying organisations.

Its appeal is in its simplicity, compact design, ease of assembly, reliability (single sealing point), wide availability and acceptance. It is especially suited for low and medium wall thickness tubing. Triple-Lok® Plus capabilities range from 500 bar for smaller sizes to 140 bar for largest – 2" size. Currently it is used in virtually every application that uses fluid power for motion control.

Triple-Lok® Plus

Parker have supplied more Triple-Lok® Plus fittings than any other manufacturer over the last seventy years. Parker engineers take a leading position in advising both customers and the international standards committees concerning 37° flare fittings. This experience, combined with optimised manufacturing methods and materials have resulted in steady product performance improvements verified by extensive testing in the laboratory. A combination of simple burst tests (with a 4 design factor), impulse and vibration tests have shown Parker Triple-Lok® Plus fittings can be uprated to higher performance levels in the smaller and in the larger sized parts. Additionally, the corrosion protection level has been improved by 100% due to effective process control.

- **Pressure Plus** – Following fitting sizes nominal pressure increased
 - 4 from 350 to 500 bar
 - 5 from 350 to 420 bar
 - 6 from 350 to 420 bar
 - 8 from 350 to 420 bar
 - 20 from 210 to 280 bar
 - 24 from 140 to 210 bar
 - 32 from 105 to 140 bar



Before tightening the nut

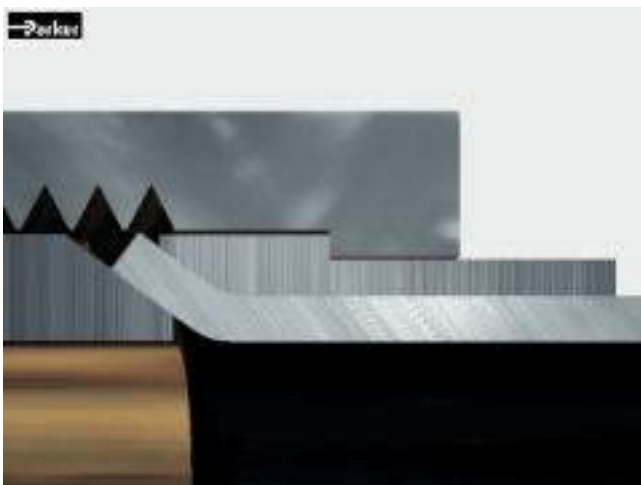

After tightening the nut

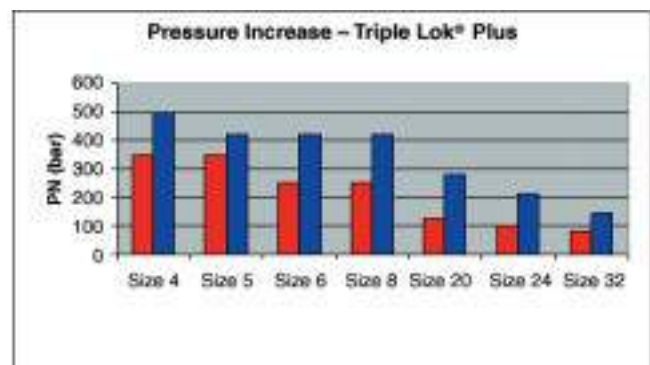

Function of fittings



Fig. C1 – Triple-Lok® fitting components (fitting body with O-ring, sleeve and nut) and assembled Triple-Lok® fitting cutaway

- **Plating Plus** – Resistance to white rust corrosion increased and exceeds far above international standards.
- **Cleanliness Plus** – Contamination is the biggest source of early component failure in hydraulic systems. Parker O-Lok® Plus fittings meet all requirements from the factory to the point of use – backed up by individual bagging.
- **Range Plus** – Parker offers the widest range of catalogue standard materials, seal combinations, styles and sizes in the industry. Only Parker has all this.

This all adds up to an unbeatable combination of performance and customer-friendly features.

Applications

Because of its long history and the heavy influence of American industry worldwide, Triple-Lok® Plus fittings designed to the original American SAE standard are found in almost every branch of hydraulics, from garbage trucks to shipbuilding. They are particularly prevalent in those branches of mobile hydraulics where medium pressure systems are used. The Triple-Lok® Plus fitting system is especially applicable where high volumes of tubes are prepared, and efficient tube flaring equipment can be employed. Still field repairs can be made with hand tools where needed.

Function of Triple-Lok® Plus fittings

The Triple-Lok® Plus fitting design is very simple. It uses an easily produced flare at the tube end to seal and hold fluid under high pressure. The fitting consists of three pieces: the body, sleeve and nut. The tube end is flared to a 37° angle and held between the fitting nose (seat) and the sleeve (support) with the nut as shown in Fig. C1, providing a very effective single seal point between the fitting nose and the tube flare.



The support sleeve serves several important functions:

- It provides a clamping surface against the rear of the tube flare and a bearing shoulder for the nut. This minimises tube twisting during assembly.
- It provides support to the tube flare. The tapered fitting nose tends to wedge open the flare during assembly. The sleeve helps to resist this expansion, allowing the fitting to be tightened adequately.
- It makes the fitting adaptable to both metric and inch O.D. tubing merely by changing the sleeve. This feature has made Triple-Lok® Plus fittings accepted worldwide.

The Triple-Lok® Plus design is also very efficient. It has the smallest seal area of all fitting designs. The seal area is only slightly larger than the fluid flow area. The small seal area results in compactness and low assembly torque compared to the holding power of the joint.

The design was standardised initially as a J.I.C. (Joint Industrial Council) design and was later adopted by the S.A.E. (Society of Automotive Engineers) and I.S.O. (International Standards Organisation) to assure complete dimensional interchangeability between various manufacturers.

Even though many manufacturers conform to the same dimensional standard, there are significant differences in actual performance of the fittings because of a variety of methods of manufacture and quality standards used.

Triple-Lok® Plus fitting components are produced using the best methods of manufacture and state of the art equipment to assure construction integrity, high strength, long service life and high quality.

The Triple-Lok® Plus body – Straight bodies are made from either cold drawn bar stock, or cold-formed construction. All shapes are of one-piece forged construction eliminating potential leak paths of multiple component constructions such as brazed shapes. The Triple-Lok® Plus

steel forged shapes also feature higher hardness for high pressure capability and minimising nose collapse (typical of sizes – 10 and under) during repeated assembly. This compares very favourably to parts of brazed construction, which typically exhibit lower hardness and hence much more nose deformation.

The Triple-Lok® Plus sleeve – Triple-Lok® Plus fitting support sleeves are cold-formed and heat treated for an optimum combination of strength and ductility. Cold forming also eliminates the problems of laps, folds, stringers, etc., associated with sleeves machined from bar stock.

The Triple-Lok® Plus nut – Nuts for all but the three largest sizes (–20, –24 and –32) are cold formed. Cold forming increases material strength and its fatigue properties, imparting high strength and longer service life to the nuts.

Larger nuts which are less severely stressed, are hot forged.

Triple-Lok® Plus fittings sealing function

As seen in Fig. C2, tightening of the nut clamps the tube flare against the body nose, producing a leak tight joint. This clamping onto the 37° cone provides a measure of elasticity to the joint helping it to resist loosening under vibration. The clamping force results in a radial load (F_R) that tends to deform the fitting nose inwards. The resistance of the nose to elastic deformation provides a constant pre-load (similar to a spring washer) keeping it tight.

The clamping force provided by the nut resists the opposing force of the fluid under pressure. The joint remains leak tight as long as the clamping force is higher than the opposing pressure load. Properly assembled Triple-Lok® Plus fittings with appropriate tube will seal consistently under pressure until the tube bursts.

Sealing in Triple-Lok® Plus fittings takes place between two smooth metal surfaces, the fitting nose and inside of the tube flare. Therefore, the sealing surfaces have to be round and smooth, free of any scratches, dents, spiral tool marks, splits or weld beads, in the seal area.

Seamless or welded and redrawn fully annealed tubing is recommended for Triple-Lok® Plus fittings for ease of flaring and tube bending.

Features, advantages and benefits

- **Pressure** – Triple-Lok® Plus fittings are rated up to 500 bar nominal pressure with 4 design factor. Triple-Lok® Plus can be used in more applications.
- **Corrosion resistance** – Triple-Lok Plus® fittings achieve corrosion resistance far above industry standards.
- **Safety** – The flared tube provides a solid and visible stop for the nut. The tube flare means there is no risk of tear out of the tube, thus giving the Triple-Lok® Plus system a reputation for safety.
- **Single seal point** – Triple-Lok® Plus fittings have only one seal (between the fitting nose and flare I.D.). This makes a highly reliable joint that is easily maintained.
- **Easy to assemble** – Small seal area under pressure makes for high-pressure capability at relatively low torque levels. This allows the use of small wrenches for easy installation and maintenance.
- **Wide temperature and media compatibility** – Metal to metal seal allows a range of uses and many applications.
- **Tube materials** – Triple-Lok® Plus fittings can be used with most tube materials, such as high and low-grade steel or stainless steel, copper and aluminium.
- **No minimum tube wall limitation** – Triple-Lok® Plus fittings are suitable for very thin to medium wall tubing. The optimum wall thickness tubing can be used, reducing overall system cost.
- **Ease of installation and maintenance** – Short tube entry means that installation is simplified and minimum tube prying is necessary when maintenance is required on the system. It is easy and quick.
- **Adaptability to metric & inch tubing** – Triple-Lok® Plus fitting sleeves make the system suitable for inch and metric tubing by merely changing the sleeve.
- **Adaptability to hose assembly** – Triple-Lok® Plus fittings allow for direct connection to 37° flare hose assemblies, the most popular industrial hose connection worldwide.
- **Forged shapes** – Triple-Lok® Plus fittings have no braze joints to leak. Forgings provide higher dependability and longer life compared to multiple component brazed constructions.
- **Hard forgings** – High hardness of Triple-Lok® Plus fittings forged shapes minimises the deformation of the 37° nose during assembly, maintaining full flow area and good reuseability.
- **Cold formed sleeves and nuts** – Sleeves and nuts in popular sizes are cold formed for high strength and toughness through optimum grain flow. This imparts high dependability and long service life.
- **International standard design** – Triple-Lok® Plus fittings offer worldwide availability and interchangeability, they conform to SAE and ISO standards. 37° fittings are the most widely used fitting type in the world.
- **Availability** – Triple-Lok® Plus fittings offer the broadest range of sizes and configurations of any fitting. This provides users with the optimum choice of tube fitting options. Standard materials offered are steel, stainless steel and brass.

Adapters – introduction

In addition to the tube fittings described earlier, there are needs for other adapters to complete hydraulic circuits which perform different functions:

- **Thread size adapters** – to reduce or expand the existing thread
- **Thread conversion adapters** – to change from one port thread to another to allow tube fitting or hose connections
- **Hose end adapters** – hose to port, hose to hose etc.
- Blanking plugs.

The range of Tube Fittings products, when used without the tube nut and ring/sleeve, can also be used as hose adapters to allow the corresponding hose assembly to connect to a port.

Adapters are frequently used in maintenance situations, where equipment is used outside the region in which it was manufactured. For example to convert BSPP threads from a European manufacturer to an American thread alternative – UNF or NPT. Adapters are therefore often the most economical way to solve short-term problems.

There are many types of threads used in the Fluid Power industry throughout the world. This section contains adapters with a wide range of those thread types including: NPT, NPTF, NPSM, BSPT, BSPP, SAE, UN/UNF, and Metric. All threads in this section are made to industry specifications with conformance shown in Table F1.

Thread	Standard
NPT	ANSI B1.21.1, FED-STD-H28/7
NPTF	SAE J476, ANSI B1.20.3, FED-STD-H28/8
NPSM	ANSI B1.20.1, FED-STD-28/7
BSPT	BS 21, ISO 7/1
BSPP	BS 2779, ISO 228/1
Metric	ISO 261, ANSI B1.13M, FED-STD-H28/21
UN/UNF*	ANSI B1.1, FED-STD-H28/2

Table F1 – Thread conformance standards

Adapters from Parker Hannifin are manufactured from drawn barstock for straight parts, or from forgings in the case of elbows, tees and crosses, to give higher durability and long term performance. Pressure ratings are based on the same requirements used for the tube fittings product ranges. Parts are corrosion protected also to the same high standard found in other Tube Fitting Division products.

Adapters – function

NPT/NPTF adapters

Commonly known as pipe thread adapters in USA, NPT and NPTF (Dryseal) adapters have tapered threads. These threads feature a 60° flank angle and 1°47" taper, as shown in Fig. F1. Because of the taper, they are commonly used in the USA as adjustable fittings in the elbow and tee forms. It has been found that although NPT/NPTF have a high static pressure capability, they are unreliable in dynamic applications, especially in the larger thread sizes 1" and above. Parker therefore recommends the use of alternative thread forms and sealing, based on elastomeric seals for new applications and designs.

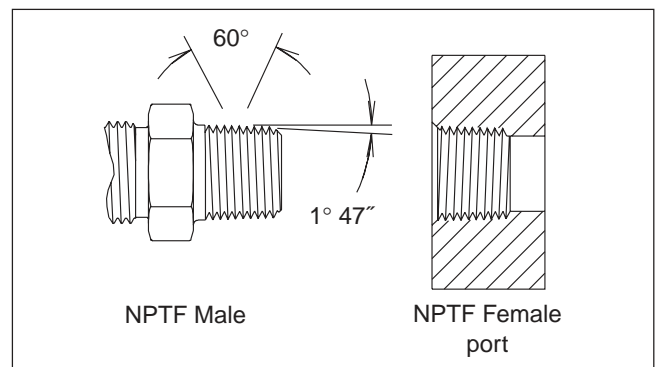

Fig. 1 – NPTF thread

NPT threads when assembled without a sealant, leave a spiral leak path at the crest-root junction as shown in Fig. F2. To seal pressurised fluid, NPT threads need a suitable sealer.

NPTF threads (Dryseal) on the other hand, when assembled, do not leave such spiral leak path. This is because they have controlled truncation at the crest and root, ensuring metal to metal crest-root contact as the male-female thread flanks make contact as seen in Fig. F3. Upon further tightening, the thread crests are flattened out until the flanks also make metal to metal contact as seen in Fig. F4. Theoretically, at least, there is no passage left for the fluid to leak, provided all surfaces are flawless and dimensions exact. In the real world, however, this is not the case and a sealant/lubricant is necessary to achieve a leak free joint even with NPTF threads. Because of the higher surface pressure contact with the NPTF design, Parker manufactures all Stainless steel adapters with the NPT thread form to reduce the possibility of thread galling (Cold welding effects).

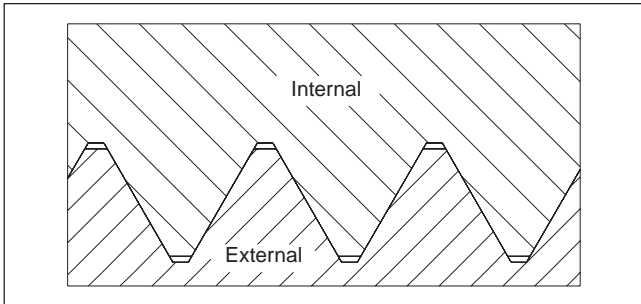

Fig. 2 – NPT – Wrench tight – No Crest-Root contact, Flank contact only.

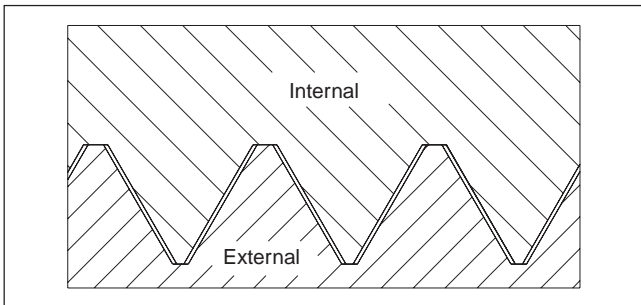

Fig. 3 – NPTF – Hand tight crest-root contact

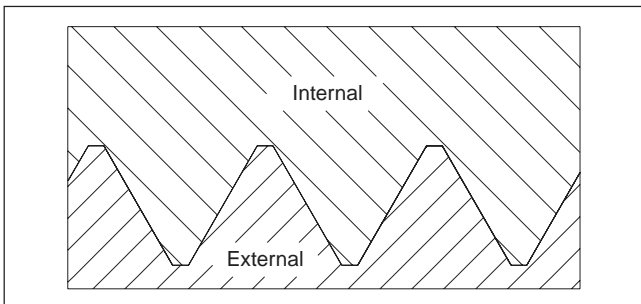

Fig. 4 – NPTF – Wrench tight crest-root and flank contact

Type of sealant/lubricant

Sealant/Lubricant assist in sealing and provide lubrication during assembly, reducing the potential for galling. Pipe thread sealants are available in various forms such as dry pre-applied, tape, paste and anaerobic liquid. Teflon tape, if not applied properly, can contribute to system contamination during assembly and disassembly. Paste sealants can also contribute to system contamination, if not applied properly. They are also messy to work with, and some types require a cure period after component installation, prior to system start up.

BSPT adapters

BSPT threads came from the British gas industry, where the outside diameter of a gas pipe was threaded at the end to allow a connection to be made. The thread form has a 55 degree flank angle, and the thread pitch is different

generally to NPT threads. Therefore the two forms are not compatible. Today the BSPT thread is used in the pneumatics industry, but use on the hydraulics side is limited. In most cases, the BSPT male stud is screwed into a BSPP – parallel – port. Thread engagement in this situation is limited, giving lower holding power compared to NPT equivalents.

To seal BSPT threads, a sealant is always needed, since the sealing function is on the threads. BSPT fittings offer a limited adjustability when using elbow or tee types, and it is easy to overtighten and damage the port thread, stud thread or both. Re-useability is also therefore very limited. For all these reasons, BSPT threads should be limited to lower pressure applications with limited dynamic changes in pressure. Parker Hannifin does not use BSPT threads in it's "Dry Technology" programmes for this reason.

UNF thread adapters

Function of UNF adapters

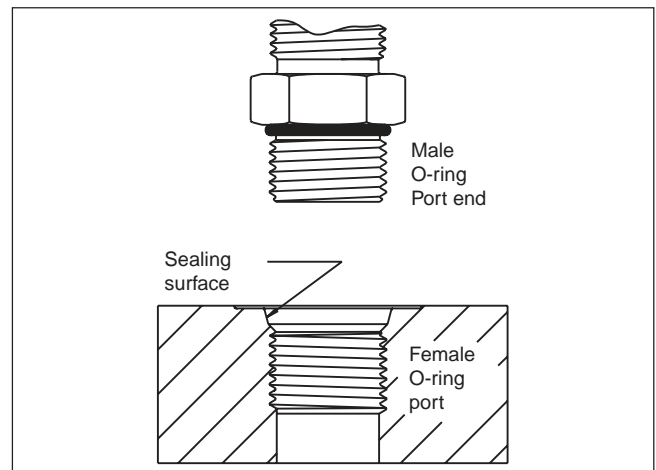

Fig. 5 – UNF port

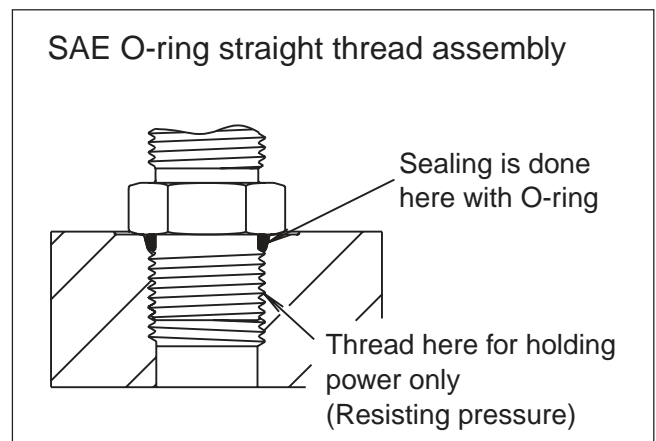

Fig. 6 – UNF port assembly

Function of fittings

Parker fittings incorporating UN/UNF thread, O-ring port studs shown in this section are for connection with the UN/UNF thread ports. They are also known as O-Ring Boss (O.R.B.) connections. When properly assembled, they give performance equal to the best leak-free port connection available.

For this style of connection, the sealing and holding functions are separated. The threads have only the holding function. Thread tolerances are wider between the male stud and female port, and so the sensitivity to damage of the threads is much lower than the NPT for example. Sealing is achieved via a high durometer O-ring seal seated in a specially machined chamfer at the top of the port thread. When energised under pressure, the O-ring seals the only leak path. Good initial compression of the seal, means that the joint is leak tight at low and high pressures.

Features, advantages and benefits

SAE straight thread

- **Elastomeric seal** – SAE straight thread O-ring connections offer a high sealing reliability, especially in dynamic and shock loading applications. The O-ring seal offers a high tolerance to minor surface imperfections and damage.
- **Ease of assembly** – This design is extremely easy to assemble, even for less experienced workers.
- **Infinite positioning of shaped fittings** – Due to the design of shaped fittings, incorporating adjustable SAE straight thread connections, they allow for infinite positioning of the port end. Aligning for tube and hose connections is much easier as compared to tapered threads.
- **Reusability** – Since the sealing and mechanical holding functions are separated, the SAE straight thread male studs can be re-used many times simply by changing the O-ring.

ISO 6149 adapters

The ISO 6149 connection design is similar to the UN/UNF, but with metric threads. The pressure performance of the connections is therefore similar, and also the user-friendly assembly characteristics. This design is recommended by the ISO standards committee for all new applications and designs. The ISO 6149 thread has gained widespread use with OEM's in the agricultural and construction equipment segments. Parker Hannifin offers one of the widest range of tube fittings and adapters to the ISO6149 standard.

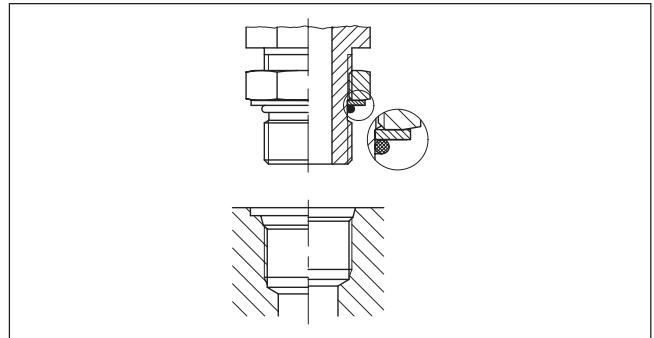

Fig. 7 – Adjustable UNF Port connection

Japanese Industrial Standard (JIS) adapters

JIS adapters are typically used as hose adapters on equipment designed or built in Japan or Korea. Sealing is achieved with a line contact between the surfaces of mating 60 degree cones on the fitting and the hose end. These adapters are made according to the JIS B8363 standard. Although they have the same cone angle and threads as the BSPP 60 degree cone adapters below, they are not interchangeable. (Longer thread lengths on the JIS female swivel fittings lead to threads bottoming out before the seal is made on the corresponding BSPP fitting).

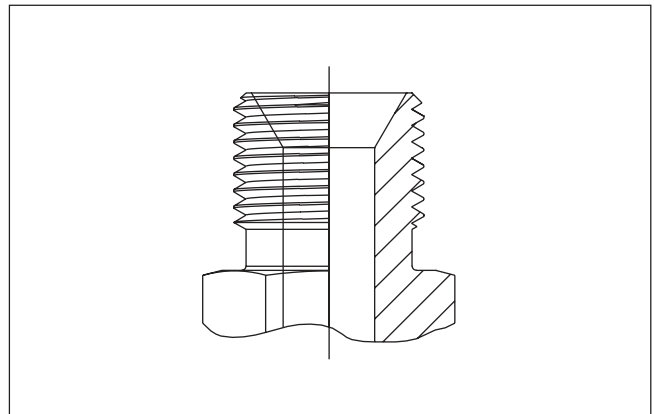

Fig. 8 – JIS adapter

BSPP thread adapters

British Standard Pipe (Parallel) threads are still the most widely type used today in the Fluid Power Industry in Europe. This section is split into two parts, covering the thread adapters and later the BSP hose adapters.

Function of 60 Deg cone

This form of BSPP adapter which has been modified to work as a hose adapter is still popular in the UK, Scandinavia and throughout the rest of Europe. These connections are standardised in BS5200. The bore of the BSPP thread is coned inwards with a 60 degree included angle to

match with a male cone of the same angle on a Swivel Female hose end see figure 9 below. When the nut is tightened, the two cone halves are clamped together to form a metallic seal. This type of connection is flexible in use, since the same thread end could also be used to screw into a BSPP threaded port. In this case a seal would be needed, normally a bonded washer consisting of a metallic outer ring and an elastomeric inner seal part.

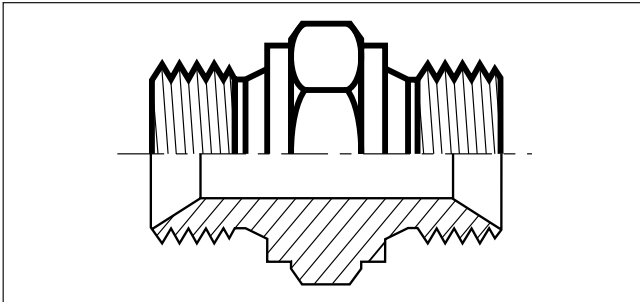

Fig. 9 – BSPP 60° cone adapter

Despite this flexibility, these adapters cannot be used as tube fittings in the same way as Triple-Lok®, O-Lok® or EO fittings, and therefore cannot be classed as a “universal system”.

Many manufacturers produce the elbow and tee adapters by brazing together straight parts. This can result in the fitting being effectively annealed during the brazing process, and therefore the material is left in its softest state. Parker tees and elbows are manufactured from high integrity forgings and offer superior long term performance.

Function of BSPP thread adapters

BSPP thread adapters are designed to work with ports that have been machined with a flat ‘spot face’ concentrically around the thread. This spot face provides a consistent flat sealing area, whether the port is in a machined valve block, or on the face of a pump housing casting. Originally, the sealing was in the form of a copper (or other ductile metal) washer, but today most adapters use some form of elastomeric seal. The four main types are shown below.

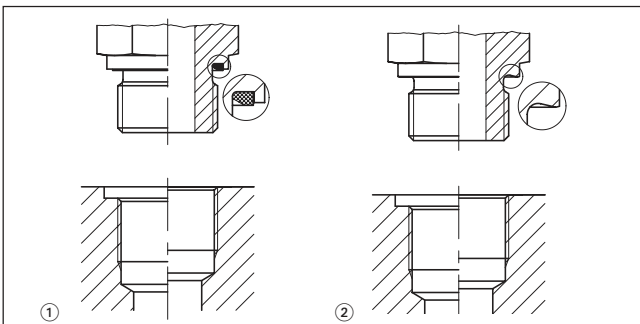

Fig. 10 – ① O-ring with retainer ring; ② Form A

The highest performance is achieved by the ED seal version, followed by the O-ring and retainer ring, bonded washer and lastly the German “Form-B” metallic sealed design. In terms of adjustable fittings, they are only normally available in the O-ring and retainer version. The ED seal design does not lend itself to adjustability.

Metric thread adapters

Metric thread adapters have developed in parallel with the BSPP threaded adapters with a similar design based around the metric thread sizes.

Pipe (NPSM) swivel adapters

Function of NPSM swivels

NPSM swivel adapters are designed for use with male NPT/NPTF hose fittings that have a 30° machined seat. NPSM adapters do not seal on the threads like most NPT thread adapters, they seal on the nose of the NPSM swivel and the seat on the male NPT/NPTF pipe thread. This creates a metal to metal seal as shown in Fig. 11. The most important preparation prior to assembly is to make certain that the mating male NPT/NPTF pipe thread has a 30° seat as shown in Fig. 12.

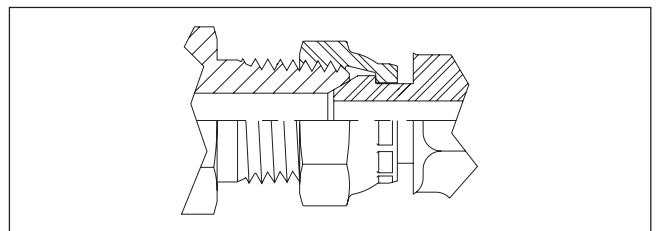

Fig. 11 – Illustration showing how NPSM swivel adapters seal on mating chamfer in male NPT thread

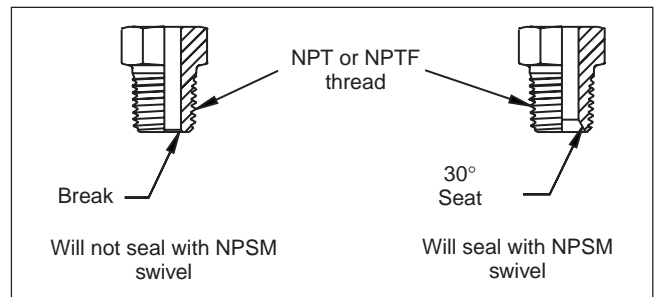

Fig. 12 – Illustration showing the required 30° seat on NPT/NPTF threads for NPSM swivel to seal

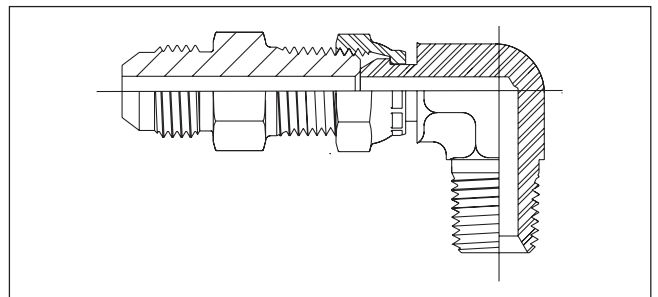
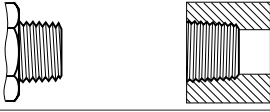
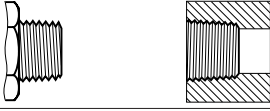
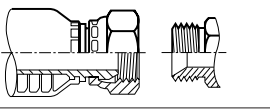
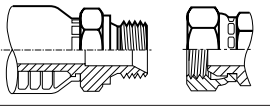
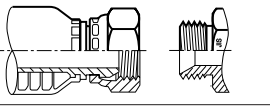
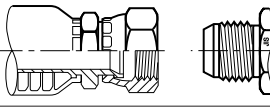
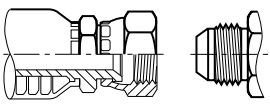
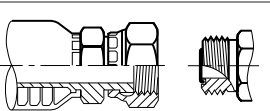

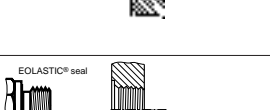
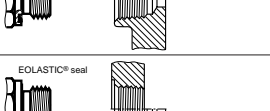
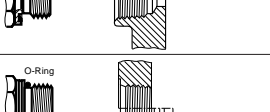
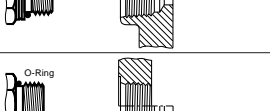
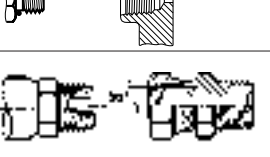

Fig. 13 – Chamfer of NPT/NPTF male thread does not provide appropriate contact for a reliable seal with cone of NPSM swivel

Thread configurations

<p>Taper thread adapters NPTF and</p>		<p>NPTF thread SAE J476-B2</p>
<p>BSPT</p>		<p>BSPT taper thread ISO 7</p>
<p>BSPP 60° cone adapters</p>		<p>BSPP male parallel thread 60° female cone BS5200</p>
<p></p>		<p>BSPP female parallel thread 60° male cone BS5200</p>
<p>JIS adapters</p>		<p>BSPP male parallel thread JIS B8363 60° female cone</p>
<p></p>		<p>BSPP female parallel thread JIS B8363 60° male cone</p>
<p>37° Flare (Triple-Lok®) and</p>		<p>SAE 37° Flare UNF thread SAE J514 ISO 8434-2</p>
<p>ORFS (O-Lok®) adapters</p>		<p>ORFS (O-ring Face Seal) UNF thread SAE J1453 ISO 8434-2</p>
<p>Male studs and female port threads</p>		<p>BSPP parallel thread O-ring and retaining ring according to ISO 1179</p>
<p></p>		<p>BSPP parallel thread with ED seal according to ISO 1179-2</p>
<p></p>		<p>Metric parallel thread with ED seal according to ISO 9974-2</p>
<p></p>		<p>Metric straight thread ISO 6149-2+3</p>
<p></p>		<p>UN/UNF threads SAE J475 thread ISO 11926-2/-3</p>
<p>NPSM female Swivel adapters</p>		<p>Hose adapters National pipe straight thread for mechanical joint 30° cone male / NPTF male thread. SAE J516</p>



Systematic fitting selection

Introduction

Product selection

Ultimate target is to find the “best solution”. This optimum solution provides high system reliability, easy assembly characteristics, low maintenance effort and avoids the use of exotic components.

This “best solution” is not the ultimately achievable technology, but an adequate solution which fulfils the requirements of the individual application with minimum system cost.

The “best solution” looks different depending on the specific criteria of the given application.

Dry Technology

Modern TFDE fittings are designed for high reliability, easy assembly and lowest total cost performance.

These products are marked *Dry Technology* and indicated grey in selection charts.

Parker recommends to select only *Dry Technology* products for all new designs.

Design criteria for fitting selection

Step 1

First clarify all design criteria for the given application or project.

Step 2

Then determine the “best solution” product. Use selection charts on following pages.

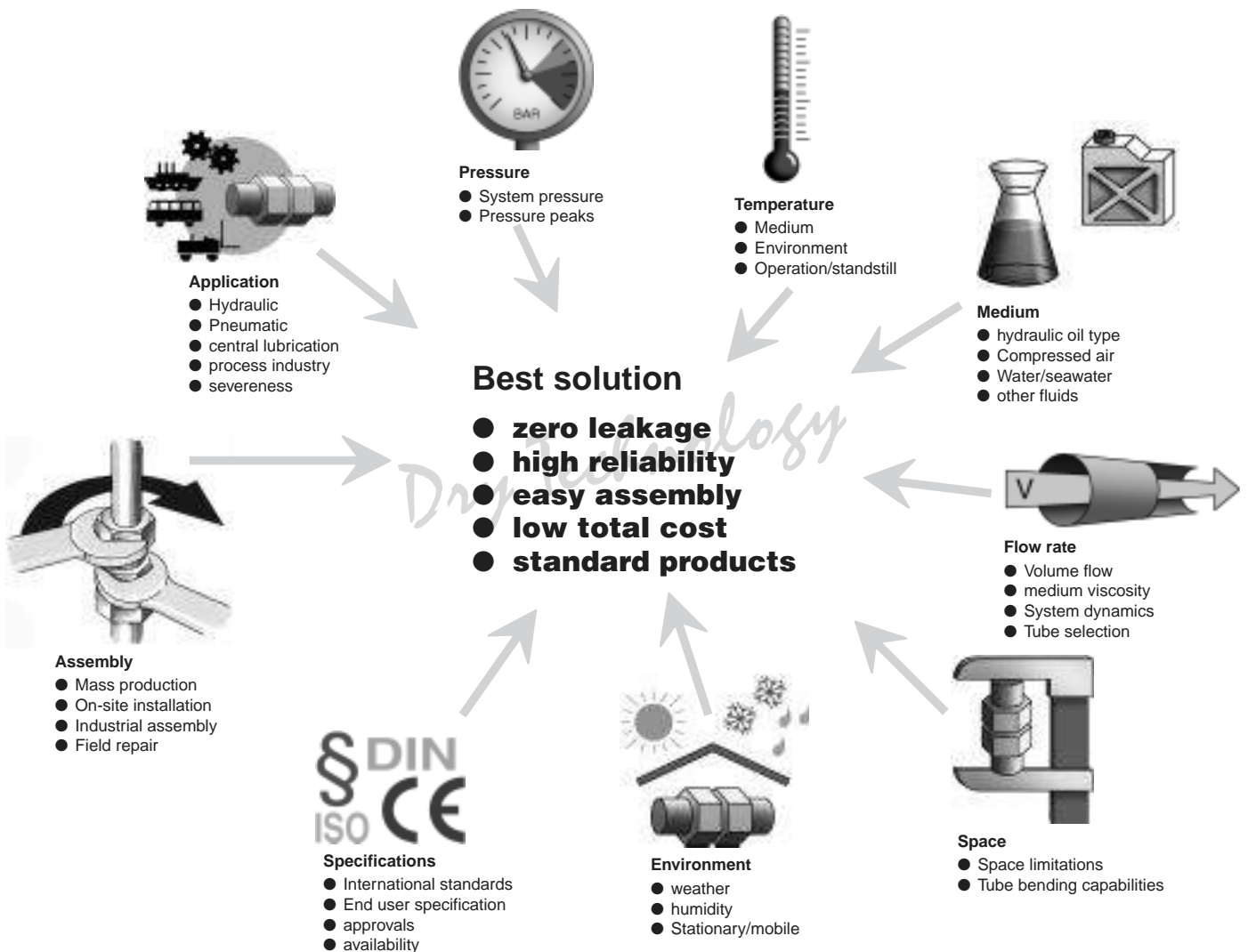

Material selection: Fitting material

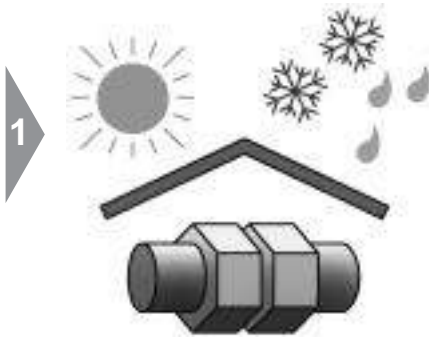

Environment

- select fitting material with suitable corrosion resistance



Medium

- select compatible fitting material

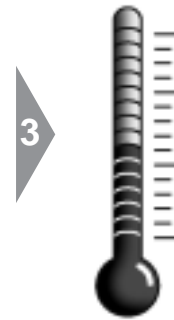

Temperature

- check suitability

Tube Material: Fitting material:	Steel, zinc-plated Steel, zinc-plated	Stainless steel Stainless steel	Copper Brass	Stainless steel Steel	Plastic Steel, Stainless steel, Brass
Performance characteristics:					
Pressure capability	Excellent	Excellent	Good	Excellent	Low
External temperature capability	Very good	Excellent	Very good	Very good	Depending on tube and material
Corrosion resistance	Good	Excellent	Very good	Good	Good
Internal media compatibility	Good	Excellent	Very good	Good	Good
Current use	Standard material combination for general use in hydraulic systems	Standard material combination for use with aggressive media or application in corrosive	Low to medium pressure applications in corrosive environment Use with compressed air (condensed water) or slightly corrosive media (water)	Special material combination for slightly corrosive environments	Special material combination for low pressure applications
Typical applications:	Machine tools, Mobile construction equipment	Shipbuilding, Offshore exploration, Process engineering, Paper machines	Central lubrication systems, Pneumatics, cooling water tubes	Some airbrake systems in railway industry wet machining area on machine tools	Pneumatic systems on machine tools central lubrication and airbrakes in truck industry

Material selection: Sealing material

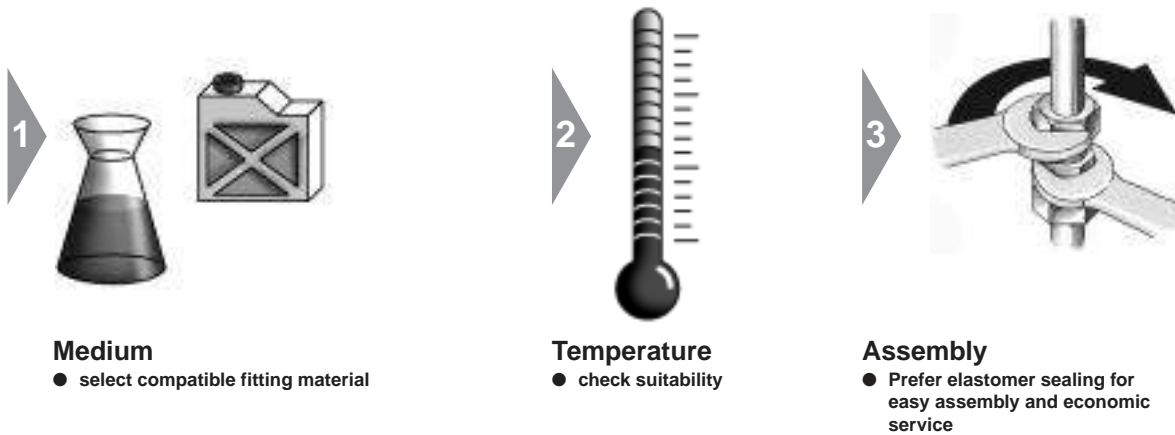

Sealing technology	metal-to-metal	nitrile rubber (NBR)-Elastomer	Fluorcarbon (FKM)-Elastomer
Performance characteristics:			
High pressure capability	Good	Excellent	Excellent
Low temperature capability	Excellent	Very good	Good
High temperature capability	Excellent	Good	Very Good
Media compability	Excellent	Good	Very Good
Long term reliability	Good	Excellent	Excellent
Assembly characteristics:			
Ease of initial assembly	Good	Excellent	Excellent
Repeated assembly	Good	Excellent	Excellent
Replacement of seal	Not possible	Easy	Easy
Current use	Suitable for aggressive media respectively for very low or very high temperatures	General use in – hydraulic – pneumatic – lubrication – airbrake systems	Hydraulic and pneumatic systems with high operating temperature process engineering: some aggressive media
Typical applications	Process engineering Agricultural Equipment	Machine tools Hydraulic presses Mobile construction equipment	Steelmill equipment Casting machines

LL/L/S Series selection for EO fittings



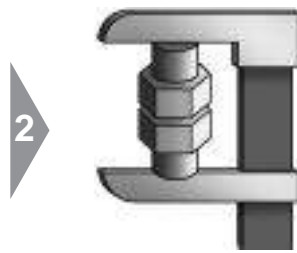

1 Pressure
 ● select series with adequate pressure performance



2 Space
 ● select series according to available space

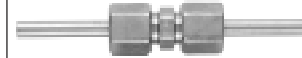

3 Specification
 ● prefer L or S series for best availability

			
Series	LL	L	S
Example of order code	G06ZLLA3C	G06ZLA3C	G06ZSA3C
Design	very Light	Light	Rigid
Performance PN	100 bar	160–500 bar	315–800 bar
Suitability for heavy duty applications	Good	Good	Excellent
Tube dimension	4, 6, 8, 10, 12 mm	6, 8, 10, 12, 15, 18, 22, 28, 35, 42 mm	6, 8, 10, 12, 14, 16, 20, 25, 30, 38 mm
Assembly Tightening effort Space requirement	Very low Very low	Normal Low	High High
Current use	Very light design for space-limited assemblies in low to medium pressure applications	medium to high pressure fitting for general use in hydraulic and pneumatic systems	Rigid design for use in heavy-duty applications
Typical applications	Central lubrication Airbrake systems fuel lines oil/gas stoves micro hydraulics	machine tools agricultural vehicles	hydraulic presses plastic injection molding steel mills shipbuilding Mobile construction equipment

Tube end selection



Pressure

- select connection type with adequate pressure performance
- prefer elastomeric seal for most reliable sealing performance

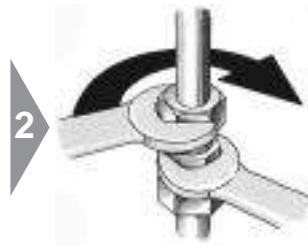

Assembly

- select product with adequate assembly process

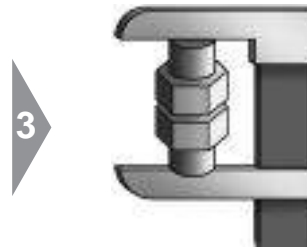

Space

- select most suitable product



Specification

- fitting type according to project specification

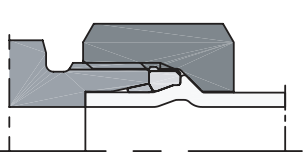
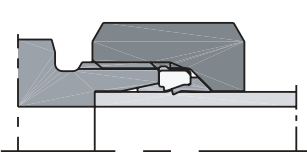
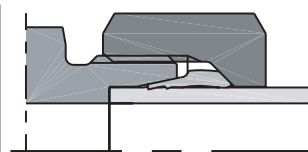

Type	EO PSR/DPR Metal seal bite type	EO-2 Soft seal bite type	EO2-FORM Tube forming
Sealing method	Metal seal	Elastomeric seal	Elastomeric seal
International Standard	ISO 8434-1	ISO 8434-1	ISO 8434-1/4
National Standards	DIN 2353 DIN 3861	DIN 2353 DIN 3861	DIN 2353
Tube compatibility	Metal and plastic tube (steel, stainless steel, copper, aluminium, polyamide ...)		Steel, stainless steel, copper alloy
Available sizes (Tube O.D.)	4 LL-12LL 6L-42L 6S-38S	4LL-6LL 6L-42L 6S-38S	Tube O.D. 6 to 42 mm 6L-42L 6S-38S
Performance seal reliability	Very good	Excellent	Excellent
Assembly Tube preparation Installation Field repair	Excellent Good Very good	Excellent Very good Excellent	Good Excellent Use EO2
Space requirements	Excellent	Excellent	Good
Current use	Most popular fitting for metric tube		Heavy duty alternative to EO/EO2 and EO wld nipple
	Traditional bite type fitting new designs	Global popularity for all	
Typical applications	General use in hydraulic, pneumatic, lubrication and coupling systems		General use in high pressure applications
	Agricultural equipment Process engineering	Hydraulic presses Injection Molding Mobile equipment Heavy machinery Ship building	Hydraulic presses Injection Molding Mobile equipment Heavy machinery Ship building

Tube end selection



Pressure

- select connection type with adequate pressure performance
- prefer elastomeric seal for most reliable sealing performance



Assembly

- select product with adequate assembly process

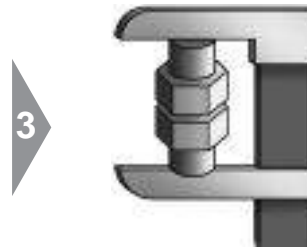

Space

- select most suitable product



Specification

- fitting type according to project specification

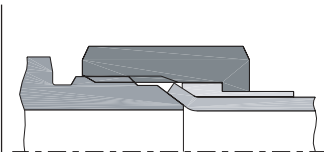
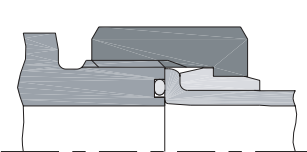
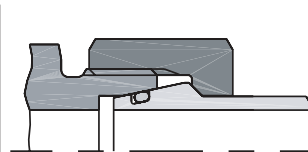

Type	EO SKA Weld nipple	O-Lok® O-Ring Face Seal (ORFS)	Triple-Lok® 37° Flare
Sealing method	Elastomeric seal	Elastomeric seal	Metal seal
International Standard	ISO 8434-4	ISO 8434-3	ISO 8434-2
National Standards	DIN 2353 DIN 3865	SAE J1453/J516	SAE J514 / J516
Tube compatibility	Weldable steel and stainless steel	Metal tube (steel, stainless steel, copper, aluminium)	
Available sizes (Tube O.D.)	6L-42L 6S-38S	Tube O.D. 6 to 50 mm Tube O.D. 1/4" to 2"	Tube O.D. 6 to 42 mm Tube O.D. 1/8" to 2"
Performance seal reliability	Excellent	Excellent	Very good
Assembly Tube preparation Installation Field repair	Difficult Excellent Difficult	Good Excellent Use braze adapter	Good Excellent Hand flaring
Space requirements	Excellent	Very good	Good
Current use	Limited use in Northern Europe and Asia	Heavy duty <i>Dry Technology</i> alternative to Triple-Lok® Most popular fitting for inch tube (metric tube on request) Mainly used in North America slowly gaining acceptance in Europe and Japan.	Used throughout the world with major usage in North America
Typical applications	Limited use for special applications Heavy machinery Ship building power plants	Hydraulic presses Injection Molding Mobile equipment Heavy machinery Ship building	General use in hydraulic, pneumatic, lubrication and coupling systems Agricultural equipment* Process engineering

Flange type selection

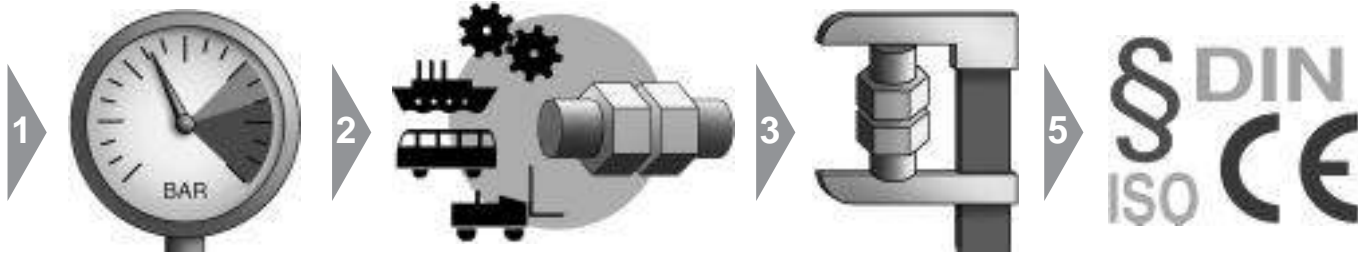

Pressure

- select flange type connection with adequate pressure performance

Application

- select suitable flange type for specific application

Space

- select flange type according to available space

Specification

- select flange type according to project specification

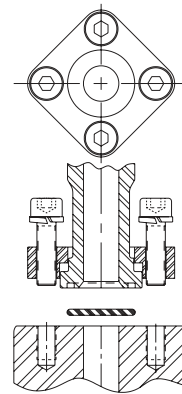
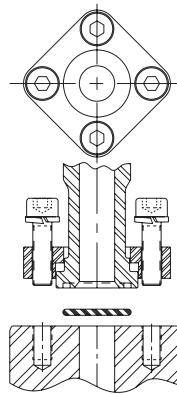
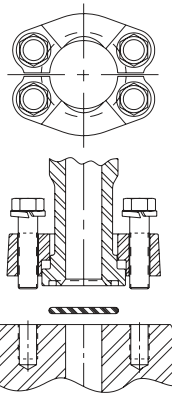

Flange type	Four screw split flange	Four screw one piece square flange	Cetop flange
Sealing method	Elastomeric seal	Elastomeric seal	Elastomeric seal
International standard	ISO 6162-1/-2	ISO 6164 (1994)	
National standard	SAE J518		Cetop
Tube compatibility	Combines weld and thread connections	Weld connection	Weld connection
Available sizes (Tube O.D.)	1/2" up to 5"	3/8" up to 4"	3/8" up to 4"
Performance seal reliability	Excellent	Excellent	Excellent
Assembly Tube preparation Installation Field repair	Good Excellent Good	Difficult Excellent Difficult	Difficult Excellent Difficult
Space requirements	Low	Low	Low
Used screws	metric screws according to: – DIN 912-8.8 (ISO 4762-8.8) or – DIN 912-10.9 (ISO 4762-10.9) UNC screws according to ASA B 18.3	metric screws according to: – DIN 912-8.8 (ISO 4762-8.8) or – DIN 912-10.9 (ISO 4762-10.9)	metric screws according to: – DIN 912-8.8 (ISO 4762-8.8) or – DIN 912-10.9 (ISO 4762-10.9)
Current use	Widely used throughout the world	Mainly used in Germany	Mainly used in Europe
Typical applications	Agriculture Hydraulic Offshore Ship building Cranes	Agriculture Hydraulic Offshore Ship building Cranes	Agriculture Hydraulic Offshore Ship building Cranes

Port/Stud selection



1

Pressure

- select connection with adequate pressure performance



2

Temperature

- Use elastomeric seal when suitable

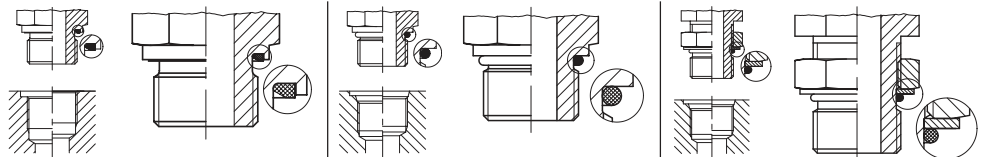

Port end selection:	Male stud with EOLASTIC-seal	Male stud with O-Ring seal	Male stud adjustable with O-Ring seal
Port description metric	Male stud with EOLASTIC-sealing	Male stud with O-ring sealing	Male stud adjustable with O-ring sealing
Thread	Metric	Metric	Metric
Example of order code EO =	GE12ZLMEDA3C	GE012ZLMA3C	VEE12ZSMORA3C
Example of order code Triple-Lok® =	8M16F82EDMXS	8M16F87OMXS;	8M18V87OMXS
Example of order code O-Lok® =	8M16F82EDMLOS	8M16F87OMLOS	8M18V87OMLOS
Thread standard (Example)	M 16 1.5 ISO 261; ISO 724; DIN 13-T5-T7	M 16 1.5 ISO 261; ISO 724; DIN 13-T5-T7	M 18 1.5 ISO 261; ISO 724; DIN 13-T5-T7
Male stud standard	DIN 3852 T11, type E ISO 9974-2	ISO 6149-2/3 DIN 3852 T3, type F	ISO 6149-2/3
Port tapping standard	DIN 3852 T1, type X, Y ISO 9974-1	ISO 6149-1 DIN 3852 T3, type W	DIN 3852 T3, Form W ISO 6149-1
Performance characteristics – pressure capacity – sealing characteristics – additional sealant required	Very high Excellent No	Very high Excellent No	High Very good No
Current use	Solid, soft sealing male studs. Known worldwide. Well suitable for using with gas and high pressure hydraulics.	New safe sealing system for all areas of application, especially suitable for high pressure hydraulics. Standard sealing for the future. Identifying marking for metric version is a groove at the collar.	New safe adjustable sealing system for all areas of application, especially suitable for high pressure hydraulics. Standard sealing for the future.
	Well suitable for softening for counter material (e.g. housing of Al-alloy).		
Port description inch	Male stud with EOLASTIC-sealing	Male stud with O-ring sealing	Male stud adjustable with O-ring sealing
Thread	BSP	UN/UNF threads	UN/UNF threads
Example of order code EO =	GE12ZLR1/4EDA3C	GE12ZL3/4UNFA3C	VEE12ZL3/4UNFA3C
Example of order code Triple-Lok® =	8-4F42EDMXS	8F50XS	8V50MXS
Example of order code O-Lok® =	8-4F42EDMLOS	8F50MLOS	8V50MLOS
Thread standard (Example)	G1/4A DIN/ISO 228-T1 BS 2779	GB: 1/4 BSPP Japan: 1/4 PF	3/4-16 UNF ISO 725/ANSI B1.1-1974
Male stud standard	DIN 3852 T11, type E ISO 1179-2	ISO 11926-2/3	ISO 11926-2/3
Port tapping standard	DIN 3852 T2, type X, Y ISO 1179-1	ISO 11926-1	ISO 11926-1
Performance characteristics – pressure capacity – sealing characteristics – additional sealant required	Very high Excellent No	Very high Excellent No	High Very good No
Current use	Solid, soft sealing male studs. Known worldwide. Well suitable for softening counter material (e.g. housing of Al-alloy). Well suitable for using with gas and high pressure hydraulics.	Predecessor of metric sealing system. Often used in USA. Well suitable for softening counter material (e.g. housing of Al-alloy). Well suitable for using with gas.	Predecessor of metric adjustable sealingsystem. Often used in USA. Well suitable for softening counter material (e.g. housing of Al-alloy).

Port/Stud selection

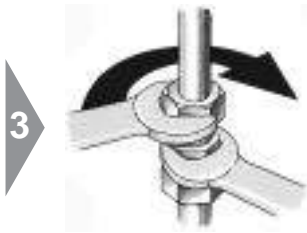

Assembly

- prefer O-Ring/ ED-seal for easy assembly and economic service
- avoid tapered threads



Application

- select standard connection for specific application

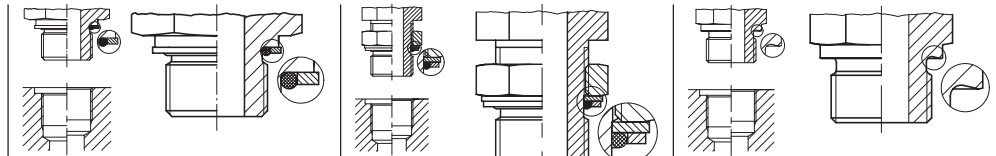

Port end selection:	Male stud O-ring retainer ring	Male stud adjustable with O-ring seal and Backup washer	Male stud with sealing by cutting face
Port description metric	Male stud adjustable with O-ring sealing	Male stud adjustable with O-ring sealing	Male stud with sealing by cutting face
Thread	Metric	Metric	Metric
Example of order code EO =	—	VEE12ZSMA3C	GE12LMA3C
Example of order code Triple-Lok® =	8M16F80MXS	8M18V80MXS	—
Example of order code O-Lok® =	—	8M18V80MLOS	—
Thread standard (Example)	M 18 1.5 ISO 261; ISO 724; DIN 13-T5-T7	M 18 1.5 ISO 261; ISO 724; DIN 13-T5-T7	M 16 1.5 ISO 261; ISO 724; DIN 13-T5-T7
Male stud standard	—	—	DIN 3852 T3, type B ISO 9974-3
Port tapping standard	DIN 3852 T1, type X, Y ISO 9974-1	DIN 3852 T1, type X, Y ISO 9974-1	DIN 3852 T1, type X, Y ISO 9974-1
Performance characteristics – pressure capacity – sealing characteristics – additional sealant required	Medium Good No	Medium to high Good No	High Medium to good No
Current use	Used in Europe and Asia-Pacific areas.	New adjustable sealing system for all areas of application.	Suitable for aggressive media respectively for very low or high temperatures, where elastic sealing cannot be used.
	Well suitable for soften counter material/e. g. housing of Al-alloy.		
Port description inch	Male stud adjustable with O-ring sealing	Male stud adjustable with O-ring sealing and Backup washer	Male stud with sealing by cutting face
Thread	BSP	BSP	BSP
Example of order code EO =	—	VEE12ZLRA3C	GE12LR1/4A3C
Example of order code Triple-Lok® =	8-F40MXS	8V40MXS	—
Example of order code O-Lok® =	—	8V40MLOS	—
Thread standard (Example)	G3/8A DIN/ISO 228-T1	G3/8A DIN/ISO 228-T1	G1/4A DIN/ISO 228-T1, BS 2779
Further standards	GB: 1/4 BSPP, Japan 1/4 PF	GB: 1/4BSPP, Japan: 1/4PF	GB: 1/4BSPP, Japan: 1/4PF
Male stud standard	ISO 1179-2	ISO 1179-3	DIN 3852 T2, type B, ISO 1179-4
Port tapping standard	ISO 1179-1; DIN 3852 T2, type X, Y	ISO 1179-1; DIN 3852 T2, type X, Y	DIN 3852 T2, type X, Y, ISO 1179-1
Performance characteristics – pressure capacity – sealing characteristics – additional sealant required	High Very good No	Medium to high Good No	High Medium to good No
Current use	Used in Europe and Asia-pacific areas. Well suitable for soften counter material (e.g. housing of Al-alloy).	Solid, soft sealing male studs. Known worldwide.	Suitable for aggressive media respectively for very low or high temperatures, where elastic sealing cannot be used.

Port/Stud selection



Specification

- select connection type according to project specification
- prefer international standards
- select ISO 6149 for new designs

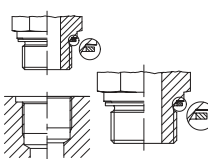
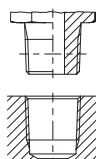
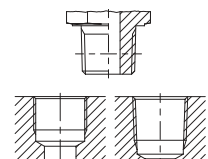
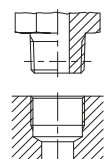
Port end selection:	 Male stud with sealing by metal sealing ring	 Male stud with sealing by taper thread	 Male stud with sealing by taper thread	 Male stud with sealing by taper thread
Port description metric	Male stud with sealing by metal sealing ring	Male stud with sealing by taper thread	—	Male stud with sealing by taper thread
Thread	Metric	NPT	—	Metric
Example of order code EO =	GE12LMAA3C	GE12L1/2NPTA3C	—	GE08LLMA3C
Example of order code Triple-Lok® =	—	8-8FMTXSS	—	—
Example of order code O-Lok® =	—	8-8FLOSS	—	—
Thread standard (Example)	M 16 1,5; ISO 261; ISO 724; DIN 13-T5-T7	1/2-14NPT ANSI B1.20.1-1983	—	M 10 1 keg DIN 158
Male stud standard	DIN 3852 T1, type A DIN 7603 (Sealing washer)	ANSI B1.20.1-1983	—	DIN 3852 T1, type C
Port tapping standard	DIN 3852 T1, type X, Y ISO 9974-1	ANSI B1.20.1-1983	—	DIN 3859 T1, type Z (parallel)
Performance characteristics – pressure capacity – sealing characteristics – additional sealant required	Low Medium No	Very high Medium Yes	—	Low Medium Yes
Current use	Partly used for pneumatics and gas applications.	Mainly used in North America. Some used in rest of the world. Male studs and port tapping are tapered. Sealing only achieved with fluid or plastic sealing material.	—	Only for low requirements due to parallel port. Leakfree performance is only achieved with fluid or plastic thread sealing material. Mainly used in Germany.
Port description inch	Male stud with sealing by metal sealing ring	Male stud with sealing by taper thread	Male stud with sealing by taper thread	Male stud with sealing by taper thread
Thread	BSPP	NPTF	BSPT	Shorter BSPT
Example of order code EO =	GE12LR1/4AA3C	—	GE12LR1/2KLA3C* *)	GE12LR1/4KEGA3C
Example of order code Triple-Lok® =	—	12FMTXS	8-8F3MXS	—
Example of order code O-Lok® =	—	12FLOS	—	—
Thread standard (Example)	G1/4A DIN/ISO 228-T1 BS 2779	3/4-14NPTF ANSI B1.20.3-1983	R1/2 ISO 7; DIN 2999-1 BS 21	R1/4 (short) DIN 3858
Further standards	GB: 1/4BSPP; Japan: 1/4PF	—	GB: 1/4 BSPT; Japan: 1/4 PT	—
Male stud standard	DIN 3852 T2, type A DIN 7603 (Sealing washer)	SAEJ 476a	ISO 7; DIN 2999-1	DIN 3852 T2, type C
Port tapping standard	DIN 3852 T2, type X, Y ISO 1179-1	SAEJ 476a ANSI B1.20.3	ISO 7/1-Rp/Rc; DIN 2999-Rc BS 21-Rp/Rc; Japan PT-Port	DIN 3852 T2, type Z (parallel)
Performance characteristics – pressure capacity – sealing characteristics – additional sealant required	Low Medium No	Very high Medium Recommended	Medium Medium Yes	Low Medium Yes
Current use	More and more unimportant. Partly used for pneumatics.	Mainly used in North America. Male studs and port tapping are tapered. The same as NPT except that closer tolerances are held to assure metal to metal contact (dryseal thread).	Mainly used in GB and Asia-Pacific areas. Male studs are tapered. Ports are mainly tapered, but can be parallel also. Leakfree performance is only achieved with fluid or plastic thread sealing material. ***Male stud end not included in the catalogue!	Only for low requirements due to parallel port. Leakfree performance is only achieved with fluid or plastic thread sealing material. Mainly used in Germany. Not to be used for BSPT ports and PT ports (Japanese Standard) due to poor thread engagement!

Orientable Fitting Selection



Pressure

- pre-select orientable fitting with sufficient pressure performance
- prefer elastomeric seal for most reliable sealing performance



Flow Rate

- select optimum solution for best flow rate and available space

Type	90° tube bend and male stud		Swivel Elbow		Adjustable Elbow
EO:	GE12LMA3C	GE12ZLMEDCF	EVW	EW	WEE
Triple-Lok®:	FMTX, F3MX	F82EDMX	—	F82EDMX+C6MX	C80MX
O-Lok®:	—	F82EDMLO	—	F82EDMLO+C6MLO	C80MLO
Design	DPR/PSR Triple-Lok® Metal sealed port	EO-2 O-Lok® Elastomeric sealed port	Adjustable elbow with pre-assembled EO-DPR/PSR	Adjustable elbow with swivel nut connection	Adjustable Elbow with adjustable male stud
Sealing method	Metal	Elastomeric	Metal	Elastomeric	Elastomeric
Performance	Good	Excellent	Good	Excellent	Very good
pressure	Good	Excellent	Good	Excellent	Good
Seal reliability	Excellent	Excellent	Very good	Very good	Very good
Flow characteristics	Bulky	Bulky	Good	Good	Very good
Compactness	Very good	Excellent	Good	Excellent	Very good
Assembly/Installation	Good	Excellent	Good	Excellent	Difficult
Field repair	Tube Outside Diameter 4 mm to 42 mm for DPR/PSR Triple-Lok® 6 mm to 50 mm and 1/4 in to 2 in	Tube Outside Diameter 4 mm to 42 mm for DPR/PSR/EO-2 Triple-Lok® and O-Lok® 6 mm to 50 mm and 1/4 in to 2 in	Tube Outside Diameter 6 mm to 42 mm for DPR/PSR	Tube Outside Diameter 6 mm to 42 mm for for DPR/PSR/EO-2 Triple-Lok® and O-Lok® 6 mm to 50 mm and 1/4 in to 2 in	Tube Outside Diameter 4 mm to 42 mm for DPR/PSR/EO-2 Triple-Lok® and O-Lok® 6 mm to 50 mm and 1/4 in to 2 in
Available sizes	Metric ISO 9974-3 BSPP ISO 1179-4 DIN 3852 Form B NPT/NPFT	Metric ISO 6149 Metric ISO 9974-2 BSPP ISO 1179-2 UN/UNF	Metric ISO 9974-3 BSPP ISO 1179-4 DIN 3852 Form B NPT/NPFT	Metric ISO 6149 Metric ISO 9974-2 BSPP UN/UNF	Metric ISO ISO 6149 Metric ISO 9974-2 BSPP ISO 1179-2 UN/UNF
Available threads	preferred use is not critical when space		not for new design	general use	general use
Current use	Agricultural Equipment process engineering	All hydraulic + pneumatic systems	Agricultural Equipment process engineering	All hydraulic + pneumatic systems	All hydraulic + pneumatic systems
Typical Applications					

Orientable Fitting Selection

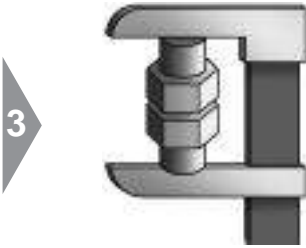

Space

- select optimum solution for available space and best flow

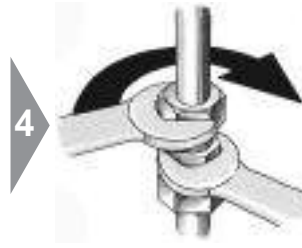

Assembly

- check, if assembly process is suitable

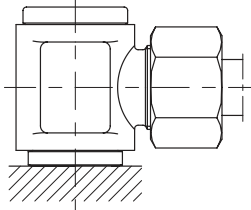
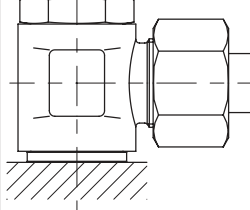
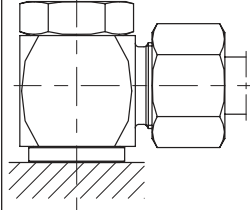
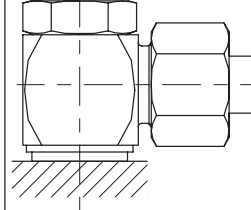
Type	Banjo		High pressure banjo	
				
EO:	DSVW	SWVE	WH DKA	WH KDS
Triple-Lok®:	—	—	—	—
O-Lok®:	—	—	—	—
Design	Fitting body with hollow bolt and cap	Fitting body with hollow bolt	Fitting body with hollow bolt	Fitting body with hollow bolt
Sealing method	Metal	Metal	Metal	Elastomeric
Performance	Low pressure	Good	Very good	Very good
pressure	Good	Good	Good	Good
Seal reliability	Good	Good	Good	Good
Flow characteristics	Good	Good	Good	Good
Compactness	Excellent	Excellent	Excellent	Excellent
Assembly/Installation	Good	Very good	Very good	Excellent
Field repair	Good	Good	Good	Excellent
Available sizes	Tube Outside Diameter 4 mm to 42 mm for DPR/PSR	Tube Outside Diameter 4 mm to 42 mm for DPR/PSR	Tube Outside Diameter 6 mm to 42 mm for DPR/PSR	Tube Outside Diameter 6 mm to 42 mm for DPR/PSR/EO-2
Available threads	— Metric BSPP —	— Metric BSPP —	— Metric BSPP —	— Metric BSPP —
Current use	Low pressure systems only, not for new designs	Low pressure systems only	Best solution for limited application space	
Typical Applications	Airbrake systems Return lines	Low to medium pressure systems	Space critical applications such as: forklift trucks Mobile hydraulics	

Standardization



Specification

- select fittings according to international standardisation
- check specification of end-customer/end user
- consider project-specific guidelines
- avoid non-standard items

ISO-fitting standards				National standards	
EO 24° fittings DIN EN ISO 8434-1/-4 (former: DIN 2353)	Triple-Lok® ISO 8434-2 ● 37° flared fittings	O-Lok® ISO 8434-3 ● O-ring face seal fittings	K4 Adapter ISO 8434-6 ● BSPP 60° cone adapter	P4 Adapter JIS B 8363 JIS BSPP 60° cone dapter	NPSM-Adapter SAE J 516 NPTF 30° cone

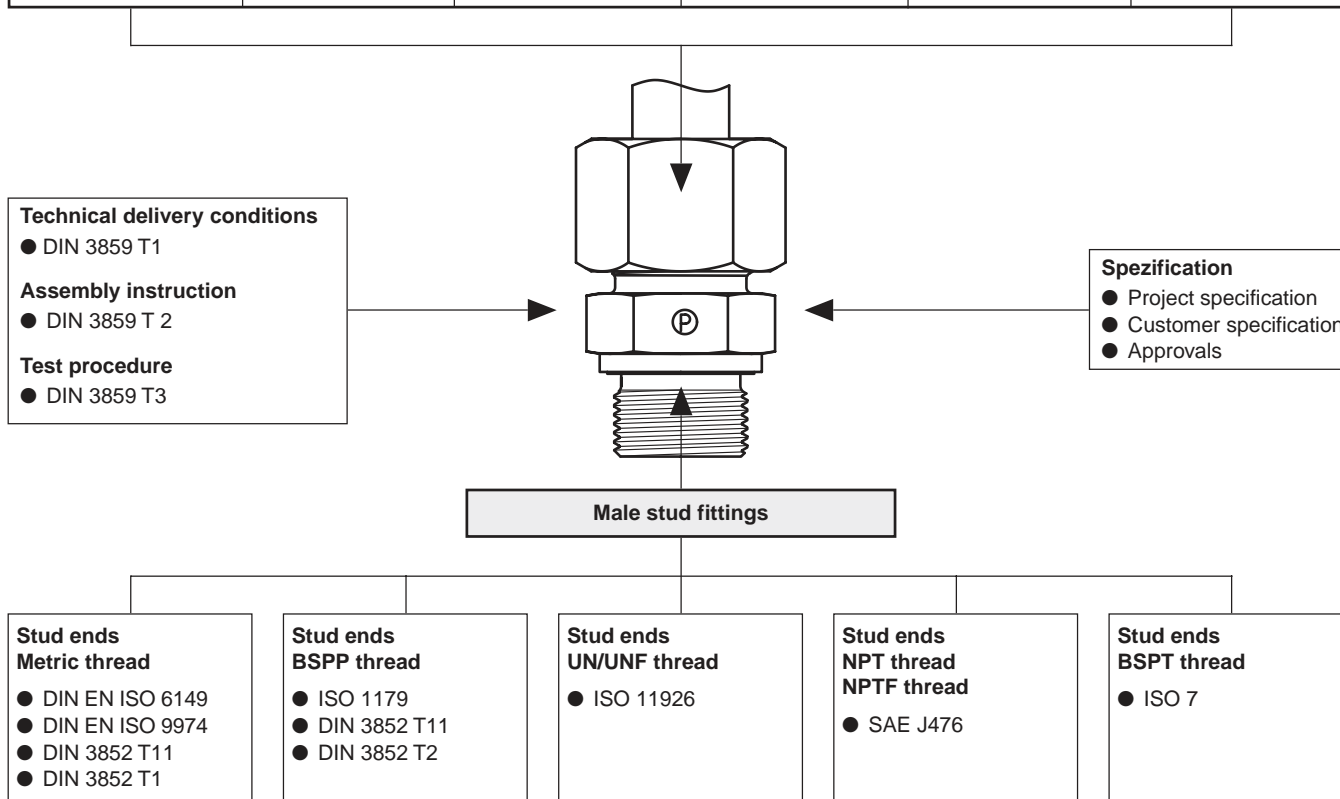

Approvals

Parker tube fittings are recognized by various acceptance organizations, among which are:

- Germanischer Lloyd (GL)
- Lloyds Register of Shipping (LR)
- Det Norske Veritas (DNV)
- American Bureau of Shipping (ABS)
- Russian Maritime Register of Shipping (RMS)
- China Classification Society (CCS)
- Deutscher Verein des Gas- und Wasserfaches (DVGW)

For other applications, Parker tube fittings also approved by diverse national authorities.

Numerous original equipment manufacturers and end-users of various industries have approved Parker tube fittings.

Attention:

Type Approvals usually are limited to certain products, applications, working conditions, validity time or other restrictions. We gladly inform you on your individual application and send out the required documentation.

Tube Specifications

Tubes with metric outside diameters

Tube material Steel	Speci- fication	Construction	Condition	Tolerances OD/ wallthickness	Surface	Suitable fitting systems				Note
						DPR/PSR/ EO-2	EO-2 Form	T- Lok®	O-Lok®	
St 37.4 (=St 35.4, 1.0255)	DIN 2391/ DIN 1630	Seamless cold drawn	NBK, DIN 2391-2	DIN 2391-1-C	phosphated, oiled or A3C (zinc plated and yellow chromated)	X	X	X	X	1)
E 235 (= 1.0308)	EN 10305		+N (= normal annealed)	EN 10305		X	X	X	X	
R37	ISO 3304		NBK (= normal annealed)	ISO 3304		X	X	X	X	2)
St 52.4 (= 1.0580)	DIN 2391		Code NBK, DIN 2391-2	DIN 2391-1		X	X	X	X	1)
E355 (= 1.0580)	EN 10305		+N (= normal annealed)	EN 10305		X	X	X	X	
R50	ISO 3304		NBK (= normal annealed)	ISO 3304		X	X	X	X	1)

Tube material Stainless steel	Speci- fication	Construction	Condition	Tolerances OD/ wallthickness	Surface	Suitable fitting systems				Note
						DPR/PSR/ EO-2	EO-2 Form	T- Lok®	O-Lok®	
1.4571 (= TP 316 Ti)	DIN 2391	Seamless cold drawn	fully annealed, DIN 17458 "m"	DIN 2391-1	plain	X	X	X	(X)	5)
1.4541 (= TP 321)						X	X	X	(X)	6)
1.4404 (= TP 316L)	EN ISO 1127 or ASTM A269		fully annealed	D4/T3* (EN ISO 1127)		X	(X)	X	X	7)
1.4301 (= TP 304)						X	(X)	X	X	8)
1.4401 (= TP 316)	EN ISO 1127	Welded tube	DIN 17457-K2 for OD 6–12 mm, cold drawn welded (CDW) with smooth outer surface for OD 14–42 mm	plain, weldseam approx. invisible	X				10)	
1.4301 (= TP 304)										
1.4541 (= TP 321)					X					

Tube material Copper	Speci- fication	Construction	Condition	Tolerances OD/ wallthickness	Surface	Suitable fitting systems				Note
						DPR/PSR/ EO-2	EO-2 Form	T- Lok®	O-Lok®	
R 290	EN 1057	Seamless tube	EN 1057	EN 1057	clean, smooth plain	X		X		11)

- 1) Recommended EO standard precision tubes for high pressure hydraulic applications. Tight tolerances for easy handling.
Good bendability and weldability.
 - 2) Tolerance on large tube OD's not as tight as EO tube.
 - 3) Precision tubes for very high pressure hydraulic applications. Tight tolerances for easy handling.
Good bendability and weldability.
 - 4) Tolerance on large tube OD's not as tight as EO tube.
 - 5) Recommended EO standard precision tubes for high pressure hydraulic applications. Tight tolerances (same as steel tubes) for easy handling.
Good weldability and corrosion resistance. () = on request
 - 6) Recommended EO standard precision tubes for high pressure hydraulic applications. Tight tolerances (same as steel tubes) for easy handling.
Good weldability. () = on request
 - 7) Common tube, OD. tolerance not as tight as EO tube. Good weldability and corrosion resistance. () = Suitable up to OD. 20 mm
 - 8) Common tube, OD. tolerance not as tight as EO tube. () = Suitable up to OD. 20 mm
 - 9) Common tube, OD. tolerance not as tight as EO tube. () = Suitable up to OD. 20 mm
 - 10) Used in Pneumatic (low pressure) applications.
 - 11) R290 is recommended class (replaced F30 = hard)
- * = For DPR/PSR/EO-2 systems: thin walled tubes which need a support sleeve require tighter tolerance class T4.

Systematic fitting selection

Tube Specifications

Tubes with imperial (inch) outside diameters

Tube material Steel	Specification	Construction	Condition	Tolerance OD/ wallthickness	Surface	Suitable		Note
						T- Lok®	O-Lok®	
Carbon steel C-1010 ¹⁾²⁾	SAE J524 (AMS 5050 J, ASTM A179)	Seamless	Fully annealed	SAE J524 (AMS 5050 J, ASTM A179)	plain, oiled	X	X	1)
	SAE J525	Welded and drawn		SAE J525		X	X	2)

Tube material Steel	Specification	Construction	Condition	Tolerance OD/ wallthickness	Surface	Suitable		Note
						T- Lok®	O-Lok®	
1.4404 (= TP 316L)	ASTM A269, ASTM A213	Seamless	Fully annealed	ASTM A269, ASTM A213	plain	X	X	3)
1.4301 (= TP 304)						X	X	4)
1.4401 (= TP 316)						X	X	
1.4404 (= TP 316L)	X	X						
1.4301 (= TP 304)	ASTM A249, ASTM A269	Welded and drawn	ASTM A249, ASTM A269	X	X			
1.4401 (= TP 316)				X	X			

Tube material Copper	Specification	Construction	Condition	Tolerance OD/ wallthickness	Surface	Suitable		Note
						T- Lok®	O-Lok®	
Copper	SAE J528 (ASTM B-75)	Seamless	Soft annealed, Temper 0	SAE J528 (ASTM B-75)	plain	X	X	4)

- 1) Recommended EO tubes for Hydraulic/Pneumatic applications
- 2) Common tubes in North-America
- 3) Recommended tubes for Hydraulic/Pneumatic applications. Good weldability and corrosion resistance
- 4) Tubes in North-America
- 5) Common tubes in North-America

Fitting selection summary

Traditional bite-type fittings have been originally developed and designed for operating conditions of fluidpower systems completely different from today's and future market requirements.

New products and improved assembly technologies have been developed and introduced by Parker to fulfill today's and future requirements of the operators of fluidpower equipment. This new tube fitting generation and the according assembly methods are classified as Dry Technology. All qualifying products are explicitly Dry Technology-labelled throughout this catalogue.

For all new designs of

- hydraulic systems
- pneumatic systems,
- coolant systems,
- lubrication systems and
- sprinkler systems

only Dry Technology-classified components should be selected.

Fully annealed

Dry technology versus traditional technology

EO-2 versus bite type

- + Elastomeric seal
- + Sufficient seal volume to compensate tube tolerance
- + High degree of fine sealing
- + Long-term reliability without retightening
- + No air ingress
- + Clear hit-home-feel at assembly
- + Easy assembly check
- + Integrated preassembly tool
- + No stress of inner cone of fitting body
- + No wear of preassembly tools
- + Direct assembly of stainless steel tubes possible (EO-2)
- + No galling of stainless steel threads
- + Existing tools and EOMAT machines can be used for efficient assembly (EO-2)
- + All parts integrated in Functional Nut (EO-2)
- + No confusion of individual ferrules
- + Less handling effort
- + Unlimited repeated assembly
- + Seal can be individually replaced
- + ISO-standardized (ISO 8434/DIN 2353)
- + Milliontimes proven product since 1993 (EO-2)
- + Interchangeable with EO Progressive Ring (EO-2)
- Higher component cost than traditional bite-type fittings
- + Low total cost
- + Best value for enduser
- + Specified mandatory from various industries, such as:
automotive production, injection molding, mobile equipment, shipbuilding and offshore exploration
- + Globally gaining popularity

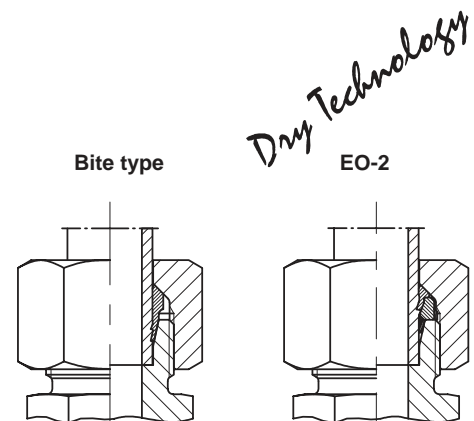

Systematic fitting selection

O-Lok® versus traditional Triple-Lok®

- + Higher pressure resistance than Triple-Lok®
- + Elastomeric seal
- + Sufficient seal volume to compensate tube tolerance
- + High degree of fine sealing
- + Long-term reliability without retightening
- + No air ingress
- + Clear hit-home-feel at assembly
- + Easy assembly check
- + Easy installation of flat-face components
- + Superior vibration resistance
- + Parflange® orbital flanging technology
- + Unlimited repeated assembly
- + Seal can be individually replaced
- + ISO-standardized (ISO 8434)
- + Milliontimes proven product
- Higher component cost than Triple-Lok®
- Parflange® machine required
- + braze sleeves can be used for field repair
- + Low total cost
- + Best value for enduser
- + Specified mandatory from various industries, such as:
agricultural equipment, mobile construction machines, injection molding
- + Globally gaining popularity

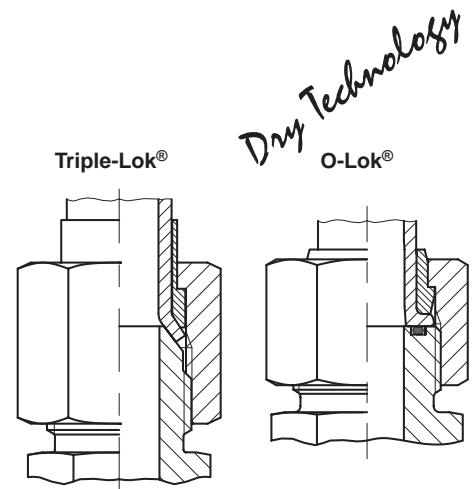

EO2-FORM versus traditional Weld nipple

- + Safe, form-fit connection
- + Easy assembly process
- + trouble-free with zinc-plated tube
- + Elastomeric seal
- + Sufficient seal volume to compensate tube tolerance
- + High degree of fine sealing
- + Long-term reliability without retightening
- + No air ingress
- + Clear hit-home-feel at assembly
- + Easy assembly check
- + Easy tube preparation
- + Easy quality inspection
- + No rework of welding
- + Use of existing EO-2 seals
- + Unlimited repeated assembly
- + Seal can be individually replaced
- + ISO-standardized (ISO 8434)
- + Basic product EO-2 is milliontimes proven
- + Interchangeable with EO Progressive Ring (EO-2)
- + No new or additional components required
- Higher component cost than traditional bite-type fittings
- EO2-FORM machine required
- + EO-2 can be used for field repair
- + Low total cost
- + Best value for enduser
- + Approved for application in hydraulic presses, injection molding, lifts, waterlocks and shipbuilding
- + Globally gaining popularity

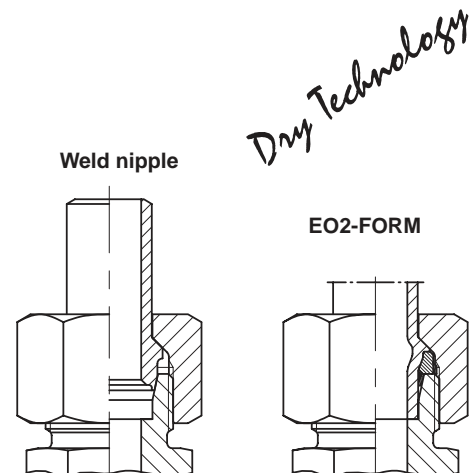

Swivel adjustable versus traditional standpipe

- + Elastomeric seal
- + High degree of fine sealing
- + Long-term reliability without retightening
- + No air ingress
- + Superior pressure rating
- + High mechanical strength
- + No blow-out at incomplete assembly
- + Easy fitting installation
- + No stress of inner cone of fitting body
- + No wear of preassembly tools
- + Unlimited repeat assembly
- + Seal can be individually replaced
- + ISO-standardized (ISO 8434/DIN 2353)
- + Milliontimes proven product since 1970
- + Interchangeable with EO standpipe fittings
- Higher component cost than traditional standpipe fittings
- + Low total cost
- + Best value for enduser
- + Specified mandatory from various industries, such as:
automotive production, injection molding, mobile equipment, shipbuilding and offshore exploration
- + Most frequently used and still gaining popularity

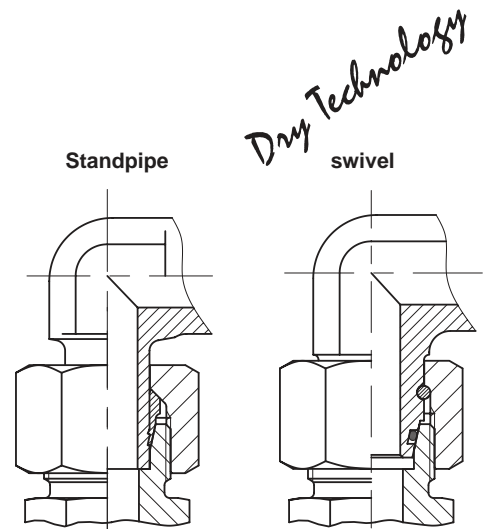

Male stud with Elastomeric or O-ring seal versus traditional Metal seal tapered thread

- + Elastomeric seal
- + High degree of fine sealing
- + Long-term reliability without retightening
- + No air ingress
- + Superior pressure rating
- + Clear hit-home-feel at assembly
- + No damage to port surface
- + Assembly and performance almost independant of port material
- + Low assembly torques
- + No metal sealing edge which may be damaged at transport or handling
- + Unlimited repeat assembly
- + Seal can be individually replaced
- + ISO - standardized (ISO 1179/ISO 6149/ISO 11926)
- + Milliontimes proven product since 1964
- + Interchangeable with traditional fittings
- + Wider product range and better availability
- Higher component cost than traditional bite-type fittings
- + Low total cost
- + Best value for enduser
- + Specified mandatory from various industries, such as:
automotive production, injection molding, mobile equipment, shipbuilding and offshore exploration
- + Most frequently used and still gaining popularity

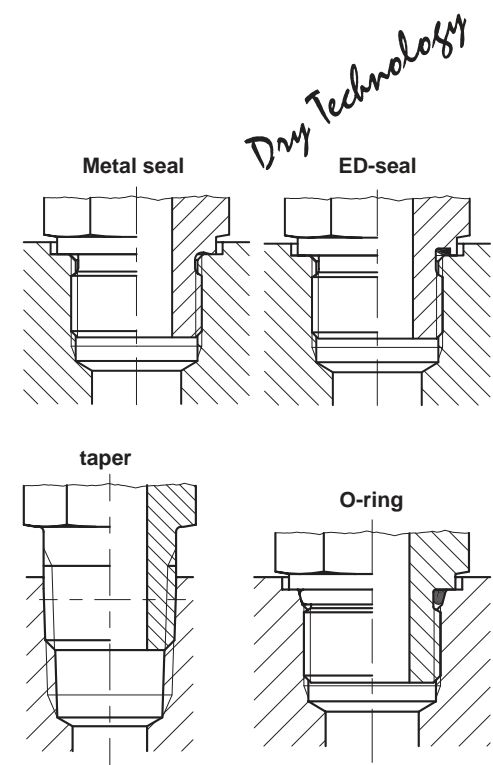

Systematic fitting selection

Locknut Adjustables versus tapered thread

- + Elastomeric seal
- + High degree of fine sealing
- + Long-term reliability without retightening
- + No air ingress
- + Good flow characteristic
- + 360° orientable
- + More compact than swivel orientable combination
- + No additional sealant required
- + Clear hit-home-feel at assembly
- + No damage to port surface
- + Assembly and performance almost independant of port material
- + Low assembly torques
- + Unlimited repeatet assembly
- + Seal can be individually replaced
- + Interchangeable with traditional fittings
- + Available in 90°, 45° elbow, T- and Run-T-configuration
- Machined spot surface required
- + Lower price than Banjo fittings
- + Low total cost
- + Best value for enduser
- + Globally gaining popularity

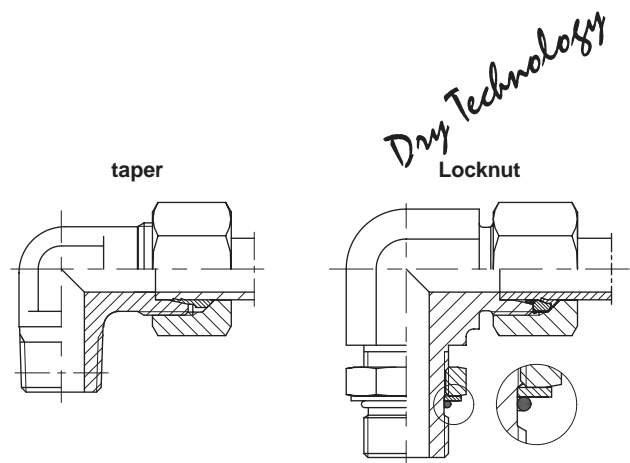

High pressure banjo versus traditional low pressure elbow

- + Elastomeric seal
- + High degree of fine sealing
- + Long-term reliability without retightening
- + No air ingress
- + 360° orientable
- + Compact design
- + Suitable for high pressure applications
- + Matching small spot surface
- + Clear hit-home-feel at assembly
- + No damage to port surface
- + Assembly and performance almost independant of port material
- + Seal does not fall off
- + Only one hollow bolt needs to be tightened
- + No hidden screw
- + Unlimited repeatet assembly
- + Seal can be individually replaced
- + Milliontimes proven product since 1980
- + Interchangeable with traditional fittings
- + Available in 90°elbow and T-configuration
- Slight flow restriction
- + Low total cost
- + Best value for enduser
- + Globally gaining popularity

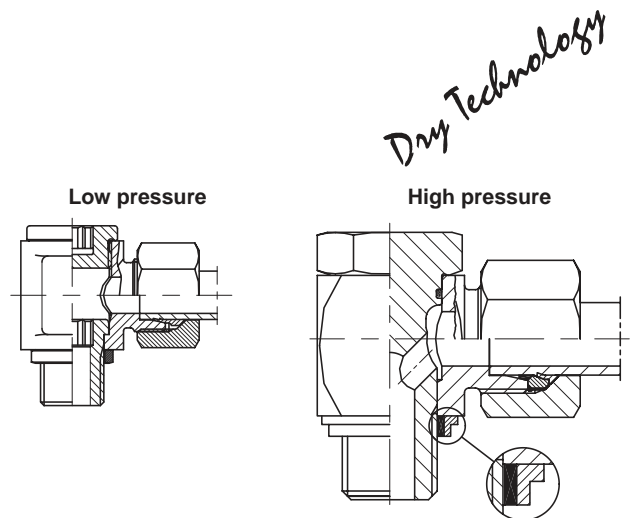



EO[®] Ermeto Original
Performance data



Pressure rating

Nominal pressure PN

The Nominal pressure PN is a figure relating to the pressure rating of a fluid component for continuous dynamic applications. It is rounded to correspond to internationally standardised ratings. Logical series of fittings are grouped together, with the nominal pressure of the group being that of the "lowest common denominator" within the group.

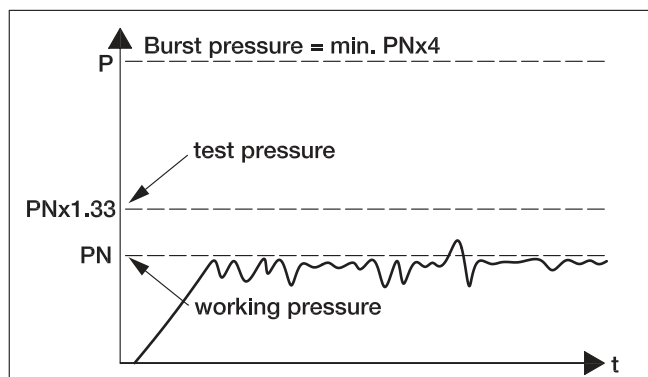

Internationally, these nominal pressures are recognised and serve to match common sizes of components together. Parker tube fittings meet or exceed common standardized pressure ratings.

To prove the long term dynamic load resistance, components are tested under pressure impulse conditions of PNx1.33, at 1Hz for **1 million cycles**. Static test burst pressures are at least 4 times the PN value.

Exception: for ball valves the static test burst pressures are at least 1.5 times the PN value according to DIN 3230 T5 and ISO 5108.

Conversion chart

Bar	Mpa	PSI
100	10.0	1450
160	16.0	2321
210	21.0	3045
315	31.5	4569
350	35.0	5075
400	40.0	5801

Pressure reductions and temperatures

Required pressure reductions (dependant on the material) with reference to the catalogue pressures for higher temperatures. Both metal fitting material and elastomeric sealing compound have to be selected according to the temperature range of the system.

Attention: Fluid Compatibility see page C5.

Fittings material	Pressure reduction of permissible operating temperatures TB in °C														
	-60	-50	-40	-35	-25	+20	+50	+100	+120	+150	+175	+200	+250	+300	+400
Steel, fittings						0%				11%	19%		28%		
Steel, tubes						0%					19%		27%		
Stainless steel, fittings						0%				11%		20%		30%	
Stainless steel, tubes						0%		5.5%	11.5%		21.5%		29%		34%
Brass, fittings															
Sealing material NBR (e.g. Perbunan)															
Sealing material FKM (e.g. Viton)															
Sealing material EPDM ¹⁾															

- Permissible operating temperature
- Ambient temperature of hydraulic and pneumatic applications
- Temperature not permissible

Perbunan = registered trademark of Bayer
 Viton = registered trademark of DuPont
¹⁾ EPDM is not compatible with oil (not normally held in Stock)

Calculation example:
 PN fitting 16S/71 = 400 bar
 Temperature = 200°C
 Material = Stainless steel
 Pressure reduction fittings = 20%
 Pressure reduction tubes = 21,5%
 PN tube 16 x 2.5/71, DIN 2413 III = 362 bar

Formula:

$$PN_{\text{fitting } 200^{\circ}\text{C}} = \frac{400 \text{ bar}}{100\%} \times (100\% - 20\%) = 320 \text{ bar}$$

$$PN_{\text{tube } 200^{\circ}\text{C}} = \frac{362 \text{ bar}}{100\%} \times (100\% - 21,5\%) = 284 \text{ bar}$$

Materials

Fittings	Raw material	Material				Fitting type									
						EO				O-Lok®			Triple-Lok®		
		Designation ²⁾	Material No.	Standard	US Designation ²⁾	Bodies	Nuts	Ferrules	Weld fittings	Bodies	Nuts	Sleeves	Bodies	Nuts	Sleeves
Steel	Barstock	11SMnPb30	1.0718	DIN EN 10277-3	SAE 12L14	X				X		X	X		X
	Free cutting steel	11SMn30	1.0715	DIN EN 10277-3	SAE 1213	X									
		46S20	1.0727	DIN EN 10277-3	SAE 1146	X									
	Forgings Free cutting steel	15S10	1.0710	DIN 1651		X									
		11SMn30 modified	1.0715	DIN EN 10087	SAE 1213 modified					X			X		
		36SMn14	1.0764	DIN EN 10087		X									
	Extrusion steel	C10C	1.0214	DIN EN 10263	SAE C1010		X				X	X		X	X
		Weldable steel	C15	1.0401	DIN 10277-3					X					
	Other	Steel at the manufacturers discretion special heat treated							X						X
	Stainless steel	Barstock	X6CrNiMoTi 17-12-2	1.4571	DIN EN 10088	ANSI 316Ti	X	X		X					
X2CrNiMo 17-13-2			1.4404	DIN EN 10088	ANSI 316L					X	X	X	X	X	X
Forgings		X6CrNiMo Ti17-12-2	1.4571	DIN EN 10088	ANSI 316Ti	X	X		X						
		X5CrNiMo 17-12-2	1.4401	DIN EN 10088	ANSI 316					X	X	X	X	X	X
Other		Stainless steel at the manufacturers discretion special heat treated							X						
Brass	Barstock	CuZn35Ni2	2.0540	DIN 17660		X	X	X							
				ASTM B16/B453	CA360/345				X	X	X	X	X	X	
	Forgings	CuZn35Ni2	2.0540	DIN 17660		X									
				ASTM B124	CA377				X			X			

- 1) Non standard fitting types like e.g. banjo fittings, rotary fittings, adjustable fittings with locknut and flanges might be made from different materials.
 2) Equivalent materials may be used

Sealings	NBR	e.g. N552-90, Perbunan (registered trademark of Bayer)
	FKM	e.g. V894-90, Viton (registered trademark of DuPont)
	EPDM	e.g. E540-80
	PTFE	e.g. Teflon (registered trademark of DuPont)
	POM	e.g. Delrin (registered trademark of DuPont)

Surface treatment

Parker tube fittings from steel are delivered worldwide with a high quality surface protection: galvanic zinc or galvanic zinc cobalt plated and yellow chromated (A3C/Q3C according DIN/ISO 4042). New Generation fittings are delivered with even higher quality surface protection: galvanic zinc plated and bright passivated with special sealer (shortcut CF).

Why zinc plated?

The requirements for corrosion resistance of tube fittings have been increasing in the past few years. Increasingly tube systems are not painted. Higher demands are requested also for an optical point of view.

The traditional black-grey surface “phosphated and oiled” (Znphr5f – DIN 50942) used for tube connections in the past does not longer meet these demands. An galvanized deposit zinc layer offers the following advantages: The corrosion resistance increases significantly due to a plating of min. 8 µ and additional sealing by chromating process. In case of scratches or nicks – which aren’t avoidable during the assembling – zinc develops a cathodical protection of the steel fitting body against localized corrosion and abrasion.

The corrosion resistance of the CF surface is 400% above standard zinc plated surfaces to meet highest requirements. The CF surface is also Chromium⁶ free to

avoid any contamination in the manufacturing process and meets future regulations as e.g. European “End of Life Vehicles“ directive.

The gold yellow or silver bright colour due to the chromating or passivation process offers an attractive appearance.

All major TFDE manufacturing locations are equipped with own modern galvanic plants. The process control is special orientated to the tube fitting product.

The users of Parker fittings profit from:

- homogeneous thickness of plating (average 13 µ), measured on outside contour for good screwable threads
- high quality above-average concerning avoidance of nicks
- very good corrosion resistance

Continuous corrosion tests like salt spray tests according to ISO 9227/5% NaCl show an average resistance of: 100 h in contrast to white rust and 350 h in contrast to red rust for A3C/Q3C surface and 500 h in contrast to white rust and 700 h in contrast to red rust for CF surface

Particular fitting series or fitting components and valves are delivered with other or modified surfaces for functional reasons or for better differentiation.

Material	Fitting system	Fitting type	Surface protection / Surface									
			A3C / Q3C Zinc/Zinc Cobalt plated, yellow chromated	A3C + Glide coating	CF Zinc plated bright passivated	CF + Glide coating	A3K Zinc plated bright passivated	Znphr5f black phosphated	Plain no coating	Plain + Glide coating	Plain + Inside silver	
New Generation steel	E02-Plus	Fitting bodies			X							
		Functional nuts				X						
	E0-Plus	Fitting body			X							
		Nuts				X						
		Progressive stop rings					X					
	E02-FORM	Bodies and nuts from E0-plus are used										
Steel	E0-2	Fitting bodies	X									
		Functional nuts	X									
	E0	Fitting bodies	X									
		Nuts		X								
		Progressive stop rings					X					
		Weld fittings						X				
			Functional nuts		X							
		E02-FORM	Bodies and nuts from E0 are used									
	O-Lok®	Fitting bodies	Fitting bodies	X								
			Nuts	X								
		Parflange® sleeves	Parflange® sleeves	X								
Brazing sleeves									X			
Triple-Lok®	Fitting bodies	Fitting bodies	X									
		Nuts	X									
	Sleeves	X										

Material	Fitting system	Fitting type	Surface protection / Surface										
			A3C / Q3C Zinc/Zinc Cobalt plated, yellow chromated	A3C + Glide coating	CF Zinc plated bright passivated	CF + Glide coating	A3K Zinc plated bright passivated	Znphr5f black phosphated	Plain no coating	Plain + Glide coating	Plain + Inside silver		
Stainless steel	EO-2	Fitting bodies								X			
		Functional nuts up to 12-L/10-S										X	
		Functional nuts from 15-L/12-S											X
	EO	Fitting bodies								X			
		Nuts up to 12-L/10-S										X	
		Nuts from 15-L/12-S											X
		Progressive rings							X				
	EO2-FORM	Bodies and nuts from EO are used											
	O-Lok®	Fitting bodies									X		
		Nuts									X		
		Sleeves									X		
	Triple-Lok®	Fitting bodies									X		
Nuts										X			
Sleeves										X			
Brass	All systems	Fitting bodies								X			
		Nuts								X			
		Sleeves & ferrules								X			

A3C/Q3C/A3K according to DIN EN ISO 4042 / Znphr5f according to DIN EN ISO 3892 and DIN 50942

Fluid compatibility

Both metal fitting material and elastomeric seal compound have to be selected according to the fluid used. Standard recommendations for static seals based on experience and sealing compound manufacturers specification. For use of sealing compounds that are used for dynamic seals like rotary fittings or non-return-valves, see note at end of table.

Fluid	Fitting material			Sealing material		
	Steel	Stainless steel	Brass	NBR	FKM	EPDM
Aceton	2	1	1	3	3	1
Acetylen	2	1	3	3	3	2
Air (oil free)	1	1	1	1	1	1
Ammoniac liquid	2	1	3	2	3	1
Ammoniac gas, cold	1	1	3	1	3	1
Animal oils (Lard oil)	2	2	2	1	1	2
Aral, Vitam BAF	1	1	X	1	1	3
Argon	1	1	1	1	1	1
Aromatic fuel – 50%	X	X	X	2	1	3
Aromatic solvents	X	2	X	2	1	X
Asphalt	3	1	3	2	1	3
ASTM-Oil, no.1	1	1	1	1	1	3
ASTM-Oil, no.2	1	1	1	1	1	3
ASTM-Oil, no.3	1	1	1	1	1	3
ASTM-Oil, no.4	1	1	1	2	1	3
ATF oil	1	1	1	1	1	3
Automotive brake fluid	1	1	1	3	3	1
Benzene	1	1	1	3	1	3
Brine (sodium chloride)	X	1	X	1	1	1
Butane	1	1	3	1	1	3
Carbon bisulphide	1	1	3	3	1	X
Carbon dioxide	1	1	1	1	2	1
Carbon oxide	1	1	1	1	1	1
Castrol, Biotec HVX	1	1	X	1	1	3
Chlorine (dry)	3	1	3	3	1	X

Performance data

Fluid	Fitting material			Sealing material		
	Steel	Stainless steel	Brass	NBR	FKM	EPDM
Compressed air	1	1	1	1	1	1
Crude oil	2	1	3	2	1	3
Cutting oil	1	1	X	1	3	1
DEA, Econa E22	1	1	X	1	X	3
DEA, Econa E46	1	1	X	1	X	3
Diesel fuel	1	1	1	1	1	3
ECOOL	1	1	X	1	1	X
ESSO, Univis 13	1	1	X	1	1	3
ESSO, Univis 26	1	1	X	1	1	3
ESSO, Univis 32	1	1	X	1	1	3
ESSO, Univis 46	1	1	X	1	1	3
Ethanol (Ethylalkohol)	1	1	1	1	3	1
Ether	1	1	1	3	3	2
FINA, Biohydran RS 38	1	1	X	1	1	3
Flue gas	3	1	3	3	2	X
FRAGOL, Hydrolub 125	1	1	X	1	X	3
Freon 11	X	X	1	2	2	3
Freon 12	1	3	1	2	1	3
Freon 22	3	1	1	3	2	3
Fuel oil	1	1	1	1	1	3
Gasoline	2	1	1	2	1	3
Gas, liquid propane (LPG)	1	1	1	1	1	3
Gas, natural	2	1	2	1	1	3
Glycerien	2	1	2	1	1	1
Glykol (Ethylenglykol)	1	1	2	1	1	1
Heating fuel oil	1	1	1	1	1	3
Helium	1	1	1	1	1	1
Houghton Safe 1120	1	1	X	3	1	1
Houghton Safe 620	1	1	X	1	2	1
Hydraulicoil – Petroleum base	1	1	1	1	1	3
Hydraulicoil – Water base	1	1	X	2	1	3
Hydrochloric acid	3	2	3	3	1	2
Hydrogene	3	1	X	3	3	3
Hydrogene peroxide	3	1	3	3	1	2
Hydrolube	1	1	1	1	1	1
Jet fuel	1	1	1	1	1	3
Jod	3	1	3	2	1	2
Kerosine	1	1	1	1	1	3
Lubricating oil SAE 10,20,30,40,50	1	1	1	1	1	3
Methane	1	1	1	1	1	3
Methanol	1	1	1	1	3	1
MIL-F-8192 (JP-9)	1	1	1	3	1	3
MIL-H-5606	1	1	1	1	1	3
MIL-H-6083	1	1	1	1	1	3
MIL-H-7083	1	1	1	1	2	1
MIL-H-8446 (MLO-8515)	1	1	2	2	1	3
MIL-L-2104 & 2104B	1	1	1	1	1	3
MIL-L-7808	2	1	3	2	1	3
Mineral oil	1	1	1	1	1	3
Natural gas	1	1	2	1	1	3
Natural gas , untreated	3	1	3	3	3	3
Natural mineral oil	1	1	3	2	1	3
Neon	3	1	1	1	1	1
Nitric acid	3	1	3	3	2	3
Nitrogene	1	1	1	1	1	1
Oil	1	1	3	1	1	3
Oxygen (gas, cold)	3	1	2	3	3	3
Ozon	1	1	3	3	1	1

Fluid	Fitting material			Sealing material		
	Steel	Stainless steel	Brass	NBR	FKM	EPDM
Petrolatum	1	1	1	1	1	3
Petroleum oil	1	1	1	1	1	3
Phosphor acid	3	3	1	3	1	2
Plantohyd 32 S	1	1	X	1	X	3
Plantohyd 40 N	1	1	X	1	1	3
Propane	1	1	1	1	1	3
R134A	1	1	1	3	3	1
Sea water	3	2	3	1	1	1
SHELL, Naturelle HF-E-46	1	1	X	1	1	3
SHELL, Tellus Oil DO 32	1	1	X	1	1	3
Silicone oil	1	1	X	1	1	1
Skydrol 500	1	1	3	3	3	1
Skydrol 7000	1	1	3	3	2	1
Soap solutions	3	1	3	1	1	1
Steam	2	1	2	3	3	1
Stoddard solvent	1	1	2	1	1	3
Sulphur dioxide	3	1	3	3	3	1
Sulphuric acid	3	2	3	3	1	3
Terpentine	2	1	3	1	1	3
Toluol	1	1	1	3	2	3
Transmission fluid	1	1	1	1	1	3
Trichlorethane	2	1	X	3	1	3
Water	2	1	1 ¹⁾	1	2	1
Xylol	1	1	1	3	1	3

Applicability: 1 = satisfactory
 2 = fair
 3 = not recommended
 X = insufficient data

NBR = e.g. Perbunan (registered trademark of Bayer)
 FKM = e.g. Viton (registered trademark of DuPont)

¹⁾ Brass is resistant against season crack under normal circumstances. If overloaded (e.g. by overassembly) the resistance especially against ammoniacal and nitric derivatives can be negatively influenced. This might cause the defect of the connection.

This fluid compatibility chart is only applicable on so called "static seals", such as O-rings and profile sealing rings (e.g. ED-seal, DOZ-seal) in tube fitting and flange systems. For fluid compatibility data of valves, rotary fittings or other multi-function components please review the relevant product pages.

Biodegradable oils

Due to environmental concerns and new legislation biodegradable oils are rapidly gaining importance for both mobile and stationary applications. Optimistic estimations say that the market share of biodegradable oils will reach 50 % by 2005 with some 80 % being synthetic ester types (HEES). The usage of non-inflammable fluids will remain limited to special applications like mining, steel mills and heavy machines.

Media

Biodegradable oils can be classified into 3 categories:

HEPG (Glycol based fluids)

- + Wide temperature range (–45°C ... 100°C)
- + Very stable against ageing
- + NBR and FKM seals are compatible
- + Moderate viscosity change with temperature
- + Water soluble
- Not mixable with mineral oils or HEES, HETG types
- Careful flushing recommended when changing from mineral oil
- Paints can be dissolved
- Care required with material compatibility (eg. do not use any zinc containing materials)
- Density > 1,100 kg/m³ possible design changes
- Price?

HETG (Vegetable-based fluids)

- + Mixable with mineral oils
- + Normal sealing material are compatible (e.g. NBR or FKM)
- + Good lubricating properties
- + Paint resistant to fluid
- + Viscosity changes with temperature are moderate
- Limited temperature range (–25° C to +70° C)
- Max. temperature not to be exceeded
- Limited lifetime
- UV and ozone sensitive
- Beware of water take-up (cracking?)
- Price?

HEES (Synthetic ester based fluids)

- + Wide temperature range (–30° C ... +90° C or over 100° C with some variants)
- + Good lifetime
- + Mixable with mineral oils
- + Normal sealing materials compatible (FKM and NBR recommended)
- + Machine paints resistant to fluid
- + Viscosity changes with temperature are moderate
- + Good lubricating properties
- Danger of hydrolysis with water take-up (filters, dryer, occlusion)
- Price?

Compatibility

Generally, TFDE steel fittings with standard NBR seals are suitable for most applications.

	–20° C 80° C	80° C 120° C
HEPG	NBR	Not suitable
Polyalkylenglycol	FKM	for Oil
HETG	NBR	–
Vegetable Oil	FKM	FKM
HEES	NBR	–
Synthetic ester	FKM	FKM

Suitable sealing compounds

Experience shows that media compatibility is not a critical issue for static seals used on tube fittings. In doubt please contact TFDE application engineering.

Pragmatic approach

If there is doubt about switching over to softseal fitting systems (ISO6149/Eolastic/O-Lok[®]/EO-2), it might be a good idea to have a close look on the existing hydraulic system. If NBR seals perform well on hoses, cylinders, valves or filters there is nothing to worry about standard TFDE fittings. Usually the design engineers know when special seal compounds like FKM have to be used.

Flow characteristics

Hydraulic systems are in most cases only rated with a flow velocity defined on the basis of experience. The pressure losses in lines are not taken into account, or measured later on when testing the system. As the pressure losses increase proportionally greater than the flow resistance, it is important to achieve the best rating of the system, that they are already taken into account when planning the tube connections. Calculation is not as difficult as it is often thought, and this chapter is intended to provide a guideline. Besides, it provides information on how excessive pressure losses can be avoided, because pressure losses result in losses in performance and excessive heat. Noise occurs, and possibly cavitation in suction lines.

Medium

All indication given with regard to flow restrictions and to flow properties refer exclusively to liquids. For gaseous media, the variable density of the gas must additionally be taken into account.

Units

$$c = \text{Flow velocity} \left[\frac{\text{m}}{\text{s}} \right]$$

$$d = \text{Pipe inside diameter [m]}$$

$$L = \text{Pipe length [m]}$$

$$p = \text{Pressure [Pa], 1 bar} = 100000 \text{ Pa}$$

$$\dot{V} = \text{Flow rate} \left[\frac{\text{m}^3}{\text{s}} \right], 1 \frac{\text{m}^3}{\text{s}} = 60000 \frac{\text{l}}{\text{min}}$$

$$\lambda = \text{Pipe friction factor}$$

$$v(T) = \text{Kinematic viscosity of the medium depending on temperature} \left[\frac{\text{m}^2}{\text{s}} \right]$$

$$\rho(T) = \text{Density of the medium depending on temperature} \left[\frac{\text{kg}}{\text{m}^3} \right]$$

$$\zeta = \text{Individual pressure loss coefficient}$$

Only base units have been used. This has the advantage that the formula do not contain correction factors and there is no danger of confusion, e.g. that values are used with the wrong unit. In case values are given in other units – the flow rate is e.g. often given in l/min – it is advisable to convert them into the base units before starting calculation.

Pressure losses in pipe lines

To calculate pressure losses in pipe lines, it must first be determined whether there is a laminar or a turbulent flow. Laminar flow is homogenous and without turbulence. In case of turbulent flow, the losses increase much more quickly.

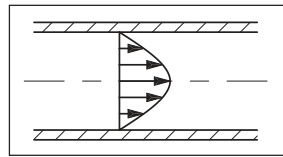

Flow profile with laminar flow

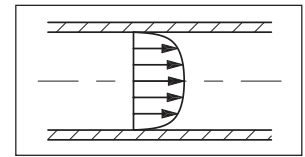

Flow profile with turbulent flow

The kind of flow is defined by the Reynolds' number. With a Reynolds' number of more than 2320, the flow changes to turbulent. The Reynold number is calculated according to the formula:

$$Re = \frac{c \cdot d}{v(T)}$$

The Reynolds' number is a non-dimensional number. The critical fluid velocity at which the flow regime can change, is thus calculated from:

$$c_{cr} = 2320 \cdot \frac{v(T)}{d} \left[\frac{\text{m}}{\text{s}} \right]$$

With a given flow rate, the fluid velocity can be calculated according to the formula:

$$c = \frac{\dot{V} \cdot 4}{d^2 \cdot \pi} \left[\frac{\text{m}}{\text{s}} \right]$$

Subsequently, the pipe friction factor λ can be calculated. The pipe friction factor λ is a function of the Reynold number and also depends on the roughness of the pipe. As hydraulically smooth pipes can generally be assumed in hydraulic applications, the pipe friction factor λ is calculated according to the following formula:

$$\text{laminar flow, (Re} < 2320\text{): } \lambda = \frac{64}{Re}$$

$$\text{turbulent flow, (Re} > 2320\text{): } \lambda = \frac{0.3164}{\sqrt[4]{Re}}$$

Finally, if all factors are known, the pressure loss in a certain pipe line can be calculated according to the formula:

$$\Delta p = \lambda \cdot \frac{L}{d} \cdot \frac{\rho(T) \cdot c^2}{2} \text{ [Pa]}$$

Calculation of individual losses

A hydraulic system does not only incorporate pipes, but also valves, fittings, pipe bends etc. that cause flow losses. These individual losses are often much higher than the pipe losses and are calculated according to the following formula:

$$\Delta p = \zeta \cdot \rho(T) \cdot \frac{c^2}{2} \text{ [Pa]}$$

Performance data

The pressure loss coefficient ζ relates to an individual hydraulic component. It covers circulation, impact and separation losses of the flow in a component. In most cases, valve or fitting manufacturers state the pressure loss coefficient of their products. The ζ values are not completely constant. The values increase in the case of very low fluid velocities. The following diagram shows the typical course of the ζ values for a component, depending on the fluid velocity, as it has been determined through a series of tests in the laboratory of the Parker Hannifin GmbH.

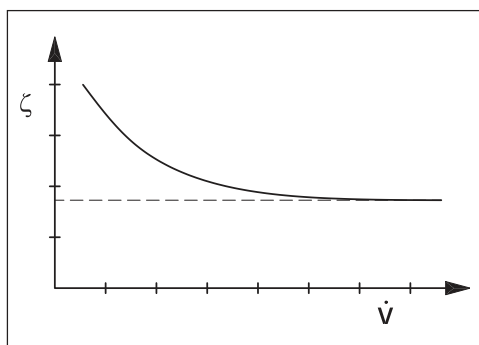

As only the flow resistances at nominal power, i.e. at higher fluid velocities, are generally calculated to rate a hydraulic plant, they may therefore be slight variations for individual sizes.

Straight fittings, e.g. G, GE, EGE, HMTX, F...MTX, F6...MX, HMLO, F...MLO, F6...MLO, ...

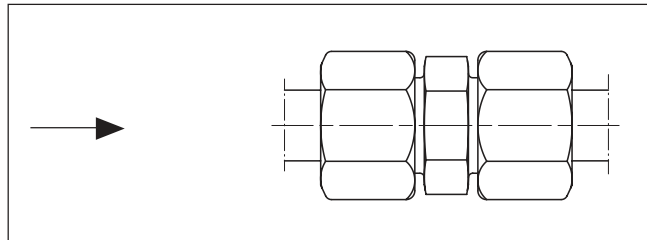

If there is a step change between the bore of the fitting and the inside diameter of the pipe, the conditions applicable to reducers (see below) are valid.

In a normal case, however, the pressure loss is very small, so that it cannot be measured by normal methods.

Literature gives a pressure loss coefficient of 0.01 to 0.05.

Reducers, e.g. RED, GR, TRMTX, TRMLO, ...

With reducers, distinction must be made between a cross section increase or reduction. The fluid velocity taken as a basis to calculate the pressure loss is always the velocity at the outlet of the flow.

Extension of the cross section:

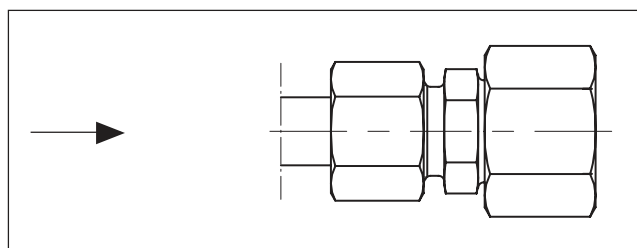

$$\zeta = \left(\frac{A_2}{A_1} - 1 \right)^2$$

With A_1 ... Inlet cross section area
 A_2 ... Outlet cross section area

The formula stated is valid for a transition angle $> 60^\circ$, and thus also for EO fittings.

It is difficult to state a figure, as the program of reducers is extensive.

With an RED style of fitting, the pressure loss coefficient ζ can vary between 1.5 and 5000, always referred to the flow velocity at the outlet.

Reduction of the cross section:

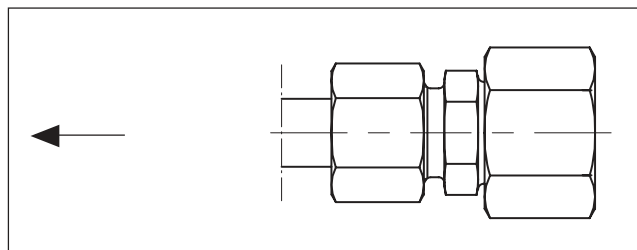

A_2/A_1	0.80	0.60	0.40	0.20
ζ	0.15	0.25	0.35	0.42

Elbow connectors, e.g. W, EW, EMTX, C...MTX, EMLO, C...MLO, ...

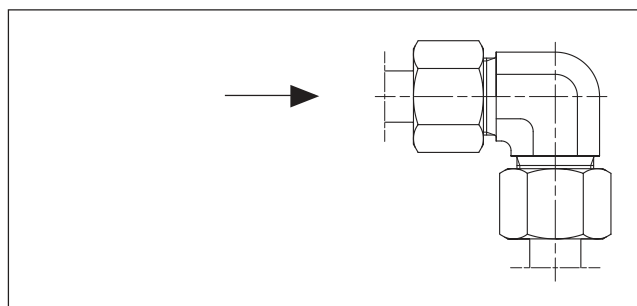

Type	Pressure loss coefficient ζ
W, EMTX, EMLO	1
EW, C...MTX, C...MLO	1

Pipe bends

With pipe bends, the pressure loss coefficient results from the ratio of bend radius to inside diameter (R/d).

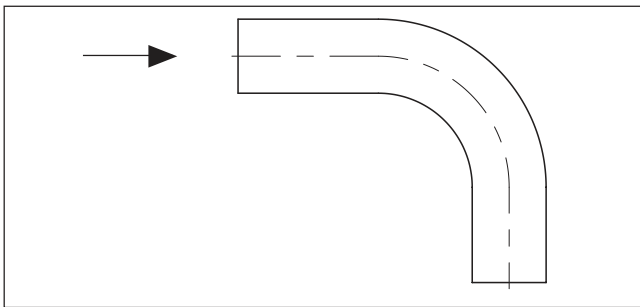

Bend radius/Inside diameter	Pressure loss coefficient ζ
2	0.21
4	0.14
6 and more	0.11

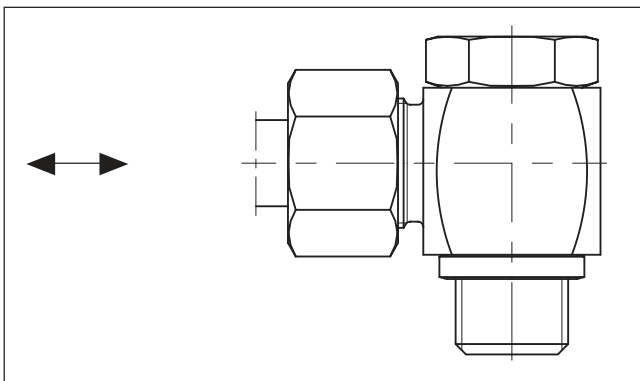
Banjo fittings

Type	Pressure loss coefficient ζ
WH	3 ... 6
SWVE	6 ... 9
DSVW	approx. 4

With WH and SWVE, the pressure loss depends on the position of the banjo bolt cross hole drilling to the tube connection aperture. The pressure loss coefficient is therefore given as a range.

Manifolds and Tee/Cross fittings

The pressure loss coefficient depends on whether the medium is divided or flows together, and in what ratio the medium is divided.

Index a: The medium flows straight through the manifold.
Index b: The medium flows through the cross branch of the manifold.

Flow division (to/from T branch)	Pressure loss coefficient ζ in case of pipe branching		Pressure loss coefficient ζ in case of pipe junction	
	\dot{V}_b / \dot{V}	ζ_a	ζ_b	ζ_a
0.6	0.07	0.95	0.40	0.47
0.8	0.20	1.10	0.50	0.73
1.0	0.35	1.30	0.60	0.92

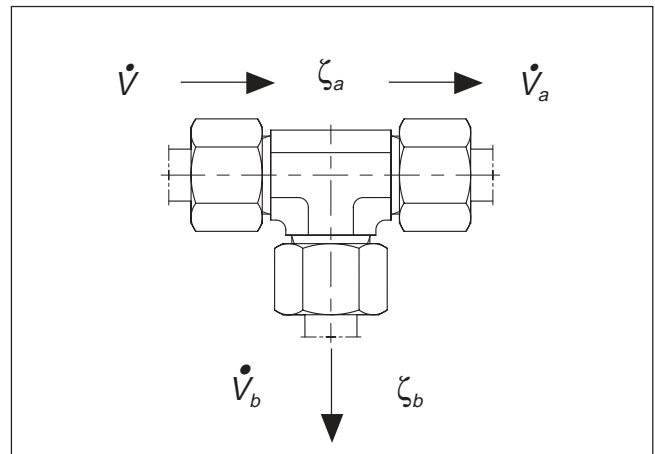

Pipe branching

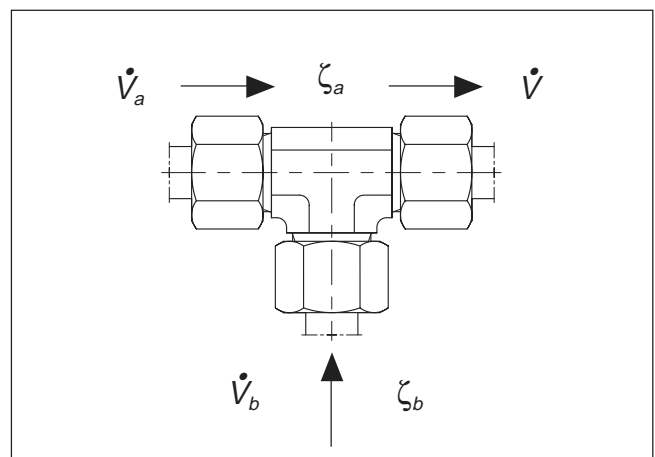

Pipe junction

Performance data

Valves, e.g. RHD, DV, VDHA, ...

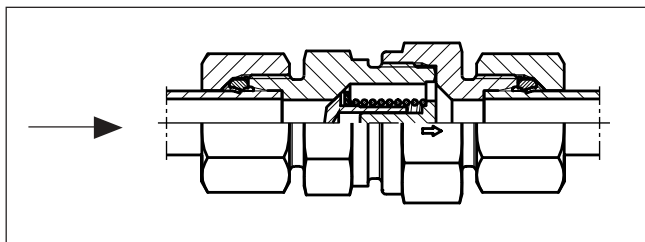

Type	Pressure loss coefficient ζ
RH ...	5,0
DV	5.5
LD	4.0
VDHA	5.0
VDHB	5.5

The pressure loss coefficient stated is always valid for the fully opened valve.

Calculation of the pressure loss Δp – example a WH 16-SR/A3C (Banjo fitting).

The pressure loss Δp is calculated according to the following formula:

$$\Delta p = \zeta \cdot \rho(T) \cdot \frac{c^2}{2} \text{ [Pa]}$$

To calculate pressure loss at a flow rate of 20 l/min is to be calculated.

The following values are known:

Pipe inside diameter $d = 12 \text{ mm} = 0.012 \text{ m}$

Density of the medium $\rho = 869,4 \text{ kg/m}^3$

(Oil manufacturer's data sheet)

Pressure loss coefficient $\zeta = 4.5$

(Average value for WH fittings)

$$\text{Flow rate } \dot{V} = \left[\frac{20}{60000} \right] = 0.000333 \left[\frac{\text{m}^3}{\text{s}} \right]$$

$$\text{Fluid velocity } c = \frac{\dot{V} \cdot 4}{d_2 \cdot \pi} = \frac{0.000333 \cdot 4}{0.012^2 \cdot \pi} = 2.95 \left[\frac{\text{m}}{\text{s}} \right]$$

The thus resulting flow loss is then:

$$\Delta p = 4.5 \cdot 869.4 \cdot \frac{2.95^2}{2} = 17000 \text{ [Pa]} = 0.17 \text{ [bar]}$$

Flow diameter and wall thickness

Determining tube size for hydraulic systems

Proper tube material, type and size for a given application and type of fitting is critical for efficient and trouble free operation of the fluid system. Selection of proper tubing involves choosing the right tube material, and determining the optimum tube size (O.D. and wall thickness).

Proper sizing of the tube for various parts of a hydraulic system results in an optimum combination of efficient and cost effective performance.

A tube that is too small causes high fluid velocity, which has many detrimental effects. In pressure lines, it causes high friction losses and turbulence, both resulting in high pressure drops and heat generation. High heat accelerates wear in moving parts and rapid aging of seals and hoses, all resulting in reduced component life. High heat generation also means wasted energy, and hence, low efficiency.

Too large tubes increase system cost. Thus, optimum tube sizing is very critical. The following is a simple procedure for sizing the tubes.

Determine required flow diameter

Use table to determine recommended flow diameter for the required flow rate and type of line.

The table is based on the following recommended flow velocities:

$$\text{Pressure lines} - 3 - 5 \left[\frac{\text{m}}{\text{s}} \right]$$

$$\text{Return lines} - 2 - 4 \left[\frac{\text{m}}{\text{s}} \right]$$

$$\text{Suction lines} - 1 \left[\frac{\text{m}}{\text{s}} \right]$$

Avoid flow rates > 8 m/s!
The resulting forces are high and can destroy the tube lines.

If you desire to use different velocities than the above, use one of the following formula to determine the required flow diameter.

$$\text{Tube - I.D. [mm]} = 4.61 * \sqrt{\frac{\text{Flow} \left[\frac{\text{ltr.}}{\text{min}} \right]}{\text{Velocity} \left[\frac{\text{m}}{\text{s}} \right]}}$$

Determine required wall thickness

Use 2nd table to determine recommended wall thickness for the required working pressure and flow diameter of the line. Therefore choose an working pressure which is equal or higher than the required working pressure.

For other tubes and tube materials you have to calculate the wall thickness and working pressure acc. to the formula shown in the tube chapter.

Maximum flow l/min	Flow diameter in millimeters		
	5 m/s Pressure lines	3 m/s Return lines	1 m/s Suction lines
1	2.1	2.7	4.6
2	2.9	3.8	6.5
3	3.6	4.6	8.0
4	4.1	5.3	9.2
5	4.6	6.0	10.3
6	5.1	6.5	11.3
7	5.5	7.0	12.2
8	5.8	7.5	13.0
9	6.2	8.0	13.8
10	6.5	8.4	14.6
12	7.1	9.2	16.0
14	7.7	10.0	17.2
16	8.2	10.6	18.4
18	8.7	11.3	19.6
20	9.2	11.9	20.6
22	9.7	12.5	21.6
24	10.1	13.0	22.6
26	10.5	13.6	23.5
28	10.9	14.1	24.4
30	11.3	14.6	25.3
32	11.7	15.1	26.1
34	12.0	15.5	26.9
36	12.4	16.0	27.7
38	12.7	16.4	28.4
40	13.0	16.8	29.2
45	13.8	17.9	30.9
50	14.6	18.8	32.6
55	15.3	19.7	34.2
60	16.0	20.6	35.7
65	16.6	21.5	37.2
70	17.2	22.3	38.6
75	17.9	23.1	39.9
80	18.4	23.8	41.2
85	19.0	24.5	42.5
90	19.6	25.3	43.7
95	20.1	25.9	44.9
100	20.6	26.6	46.1
110	21.6	27.9	48.4
120	22.6	29.2	50.5
130	23.5	30.3	52.6
140	24.4	31.5	54.5
150	25.3	32.6	56.5
160	26.1	33.7	58.3
170	26.9	34.7	60.1
180	27.7	35.7	61.8
190	28.4	36.7	63.5
200	29.2	37.6	65.2
220	30.6	39.5	68.4
240	31.9	41.2	71.4
260	33.2	42.9	74.3
280	34.5	44.5	77.1
300	35.7	46.1	79.8
320	36.9	57.6	82.5
340	38.0	49.1	85.0
360	39.1	50.5	87.5
380	40.2	51.9	89.9
400	41.2	53.2	92.2
450	43.7	56.5	97.8
500	46.1	59.5	103.1



Tube wall thickness

Flow diameter [mm]	Max. working pressure [bar] for steel tubes St37.4 NBK calculated acc. to DIN 2413 III for dynamic load										
	Tube wall thickness [mm]										
	0.5	1	1.5	2	2.5	3	3.5	4	5	6	8
1.0	551	692	757	794	818						
1.5	458	614	692	740	771	794					
2.0	391	551	638	692	730	757	778	794			
2.5	342	500	591	651	692	723	747	766	794		
3.0	303	458	551	614	659	692	719	740	771	794	
4.0	248	391	485	551	600	638	668	692	730	757	794
5.0	209	342	433	500	551	591	624	651	692	723	766
6.0	181	303	391	458	509	551	585	614	659	692	740
7.0	160	273	357	422	474	516	551	581	628	664	715
8.0	143	248	328	391	443	485	521	551	600	638	692
9.0	129	227	303	365	415	458	494	524	575	614	671
10.0	118	209	282	342	391	433	469	500	551	591	651
11.0	108	194	264	321	370	411	447	478	529	570	632
12.0	100	181	248	303	351	391	427	458	509	551	614
13.0	93	170	233	287	333	373	408	439	491	533	597
14.0	87	160	221	273	318	357	391	422	474	516	581
15.0	82	151	209	260	303	342	376	406	458	500	565
16.0	77	143	199	248	290	328	361	391	443	485	551
17.0	73	136	190	237	278	315	348	378	429	471	537
18.0	69	129	181	227	267	303	336	365	415	458	524
19.0	66	123	173	218	257	292	324	353	403	445	512
20.0	63	118	166	209	248	282	313	342	391	433	500
21.0	60	113	160	202	239	273	303	331	380	422	489
22.0	58	108	154	194	231	264	294	321	370	411	478
23.0	55	104	148	188	223	256	285	312	360	401	468
24.0	53	100	143	181	216	248	277	303	351	391	458
25.0	51	97	138	175	209	240	269	295	342	382	448
26.0	49	93	133	170	203	233	261	287	333	373	439
27.0	48	90	129	165	197	227	254	280	325	365	430
28.0	46	87	125	160	192	221	248	273	318	357	422
29.0	44	85	121	155	186	215	241	266	310	349	414
30.0	43	82	118	151	181	209	235	260	303	342	406
31.0	42	80	115	147	177	204	230	254	297	335	399
32.0	40	77	111	143	172	199	224	248	290	328	391
33.0	39	75	108	139	168	194	219	242	284	321	384
34.0	38	73	106	136	164	190	214	237	278	315	378
35.0	37	71	103	132	160	185	209	232	273	309	371
36.0	36	69	100	129	156	181	205	227	267	303	365
37.0	35	68	98	126	153	177	200	222	262	298	359
38.0	34	66	96	123	149	173	196	218	257	292	353
39.0	33	64	93	121	146	170	192	213	252	287	347
40.0	33	63	91	118	143	166	188	209	248	282	342
42.0	31	60	87	113	137	160	181	202	239	273	331
44.0	30	58	84	108	132	154	175	194	231	264	321
46.0	29	55	80	104	127	148	168	188	223	256	312
48.0	27	53	77	100	122	143	163	181	216	248	303
50.0	26	51	75	97	118	138	157	175	209	240	295
52.0	25	49	72	93	114	133	152	170	203	233	287
54.0	24	48	69	90	110	129	147	165	197	227	280
56.0	24	46	67	87	107	125	143	160	192	221	273
58.0	23	44	65	85	103	121	139	155	186	215	266
60.0	22	43	63	82	100	118	135	151	181	209	260
65.0	20	40	58	76	93	110	126	141	170	197	245
70.0	19	37	55	71	87	103	118	132	160	185	232
75.0	18	35	51	67	82	97	111	125	151	175	220
80.0	17	33	48	63	77	91	105	118	143	166	209



Dimensioning

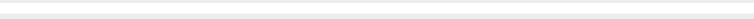

Index

Overview EO 24° cone connections	D3
Not recommended	D4
EO 24° cone end (DIN 3861/ISO 8434-1)/dimension	D4
EO 24°-DKO swivel connector (DIN 3861/DIN EN ISO 8434-4)/dimensions	D5
Overview O-Lok® connections	D6–D7
O-Lok® end (ISO 8434-3/SAE J1453)/dimensions	D8
O-Lok® swivel connector (ISO 8434-3/SAE J1453)/dimensions	D9
Overview Triple-Lok® connections	D10–D11
Triple-Lok® end (ISO 8434-2/SAE J1514)/dimensions	D12
Triple-Lok® swivel connector (ISO 8434-3/SAE J514)/dimensions	D13
DIN 60° cone end (DIN 7631)/dimensions	D14
Adapter 60° cone end (ISO/DIS 8434-6)/dimensions	D15
NPSM Swivel adapters (SAE J516)/dimensions	D16
Port end dimensions for tube fittings	D17–D19

Overview EO 24° cone connections

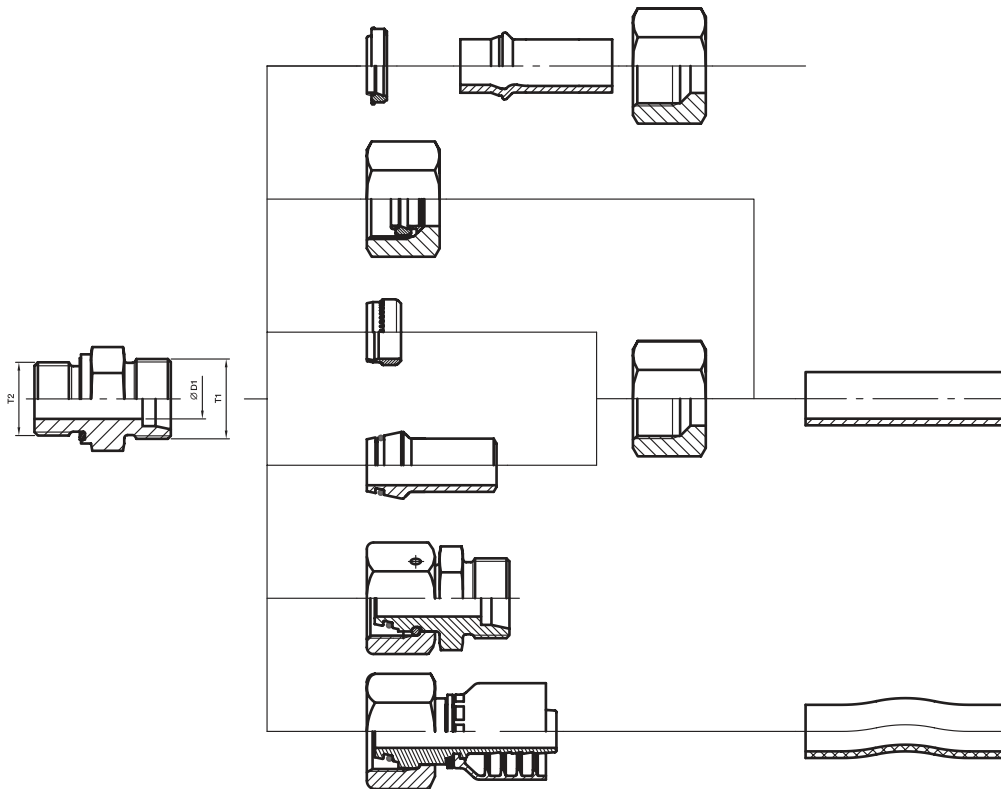

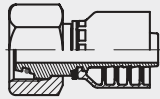
Size	D1 Tube O.D. mm	T1 Thread metric	Thread O.D. mm	T2 Port thread				
				BSP	metric	BSP tap. (short)	metric tapered	
LL	04	M 08×1	8.0	G 1/8 A	M 08×1	R 1/8 tap.	M 08×1 tap.	
	05	M 10×1	10.0	G 1/8 A	M 08×1			
	06	M 10×1	10.0	G 1/8 A	M 10×1	R 1/8 tap.	M 10×1 tap.	
	08	M 12×1	12.0	G 1/8 A	M 10×1	R 1/8 tap.	M 10×1 tap.	
	10	M 14×1	14.0	G 1/4 A		R 1/4 tap.		
	12	M 16×1	16.0	G 1/4 A		R 1/4 tap.		
L	06	M 12×1.5	12.0	G 1/8 A	M 10×1		M 10×1 tap.	1CAxx-6-yy
	08	M 14×1.5	14.0	G 1/4 A	M 12×1.5		M 12×1.5 tap.	1CAxx-8-yy
	10	M 16×1.5	16.0	G 1/4 A	M 14×1.5		M 14×1.5 tap.	1CAxx-10-yy
	12	M 18×1.5	18.0	G 3/8 A	M 16×1.5		M 16×1.5 tap.	1CAxx-12-yy
	15	M 22×1.5	22.0	G 1/2 A	M 18×1.5		M 18×1.5 tap.	1CAxx-15-yy
	18	M 26×1.5	26.0	G 1/2 A	M 22×1.5		M 22×1.5 tap.	1CAxx-18-yy
	22	M 30×2	30.0	G 3/4 A	M 26×1.5		M 26×1.5 tap.	1CAxx-22-yy
	28	M 36×2	36.0	G 1 A	M 33×2			1CAxx-28-yy
	35	M 45×2	45.0	G 1 1/4 A	M 42×2			1CAxx-35-yy
	42	M 52×2	52.0	G 1 1/2 A	M 48×2			1CAxx-42-yy
S	06	M 14×1.5	14.0	G 1/4 A	M 12×1.5		M 12×1.5 tap.	1C9xx-6-yy
	08	M 16×1.5	16.0	G 1/4 A	M 14×1.5		M 14×1.5 tap.	1C9xx-8-yy
	10	M 18×1.5	18.0	G 3/8 A	M 16×1.5		M 16×1.5 tap.	1C9xx-10-yy
	12	M 20×1.5	20.0	G 3/8 A	M 18×1.5		M 18×1.5 tap.	1C9xx-12-yy
	14	M 22×1.5	22.0	G 1/2 A	M 20×1.5		M 20×1.5 tap.	1C9xx-14-yy
	16	M 24×1.5	24.0	G 1/2 A	M 22×1.5		M 22×1.5 tap.	1C9xx-16-yy
	20	M 30×2	30.0	G 3/4 A	M 27×2			1C9xx-20-yy
	25	M 36×2	36.0	G 1 A	M 33×2			1C9xx-25-yy
	30	M 42×2	45.0	G 1 1/4 A	M 42×2			1C9xx-30-yy
	38	M 52×2	52.0	G 1 1/2 A	M 48×2			1C9xx-38-yy

xx - Fitting Series • yy - Hose Size
From Parker hose fitting (HPDE and PFDE)

Dimensioning

Not recommended

	Reason
	<p>High risk of hose blow off. For ferrule assembly special hardened tools are required.</p>
	<p>With the use of the Universal-connection high risk of cracks in 24° cone area of stud ends sizes 6-L up to 18-L.</p>

EO 24° cone end (DIN 3861/ISO 8434-1)/dimension

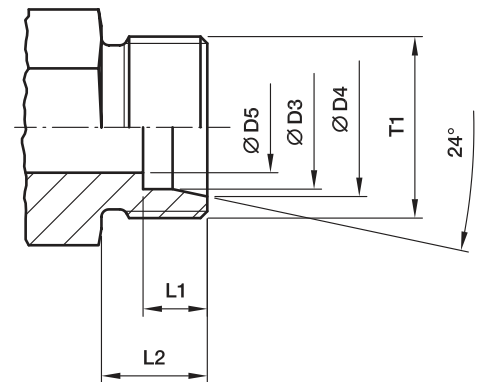

Tube O.D. Size	T1	Ø D3 mm	Ø D4 mm	Ø D5 mm	L1 mm	L2 mm
04-LL	M 8×1	04	5.0	3.0	4.1	8
06-LL	M 10×1	06	7.0	4.5	5.6	8
08-LL	M 12×1	08	9.5	6.0	5.6	9
10-LL	M 14×1	10	11.5	8.0	5.6	9
12-LL	M 16×1	12	13.5	10.0	6.1	9
06-L	M 12×1.5	06	8.1	4.0	7.1	10
08-L	M 14×1.5	08	10.1	6.0	7.1	10
10-L	M 16×1.5	10	12.3	8.0	7.1	11
12-L	M 18×1.5	12	14.3	10.0	7.1	11
15-L	M 22×1.5	15	17.3	12.0	7.1	12
18-L	M 26×1.5	18	20.3	15.0	7.6	12
22-L	M 30×2	22	24.3	19.0	7.6	14
28-L	M 36×2	28	30.3	24.0	7.6	14
35-L	M 45×2	35	38.0	30.0	10.6	16
42-L	M 52×2	42	45.0	36.0	11.1	16
06-S	M 14×1.5	06	8.1	4.0	7.1	12
08-S	M 16×1.5	08	10.1	5.0	7.1	12
10-S	M 18×1.5	10	12.3	7.0	7.6	12
12-S	M 20×1.5	12	14.3	8.0	7.6	12
14-S	M 22×1.5	14	16.3	10.0	8.1	14
16-S	M 24×1.5	16	18.3	12.0	8.6	14
20-S	M 30×2	20	22.9	16.0	10.6	16
25-S	M 36×2	25	27.9	20.0	12.1	18
30-S	M 42×2	30	33.0	25.0	13.6	20
38-S	M 52×2	38	41.0	32.0	16.1	22

EO 24°-DKO swivel connector (DIN 3865/DIN EN ISO 8434-4)/dimensions

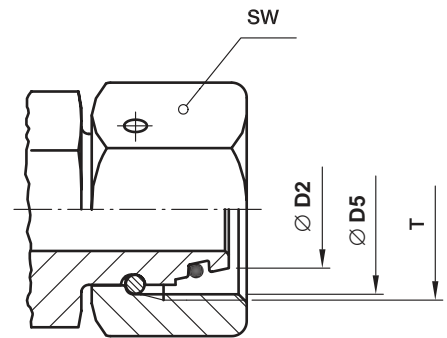

Tube O.D. Size	T	Ø D2 mm	Ø D5 mm Thread core diameter	SW mm
06-L	M 12×1.5	5.5	10.38	14
08-L	M 14×1.5	7.5	12.38	17
10-L	M 16×1.5	9.7	14.38	19
12-L	M 18×1.5	11.7	16.38	22
15-L	M 22×1.5	14.7	20.38	27
18-L	M 26×1.5	17.7	24.38	32
22-L	M 30×2	21.7	27.84	36
28-L	M 36×2	27.7	33.84	41
35-L	M 45×2	34.5	42.84	50
42-L	M 52×2	41.5	49.84	60
06-S	M 14×1.5	5.5	12.38	17
08-S	M 16×1.5	7.5	14.38	19
10-S	M 18×1.5	9.7	16.38	22
12-S	M 20×1.5	11.7	18.38	24
14-S	M 22×1.5	13.5	20.38	27
16-S	M 24×1.5	15.5	22.38	30
20-S	M 30×2	19.5	29.84	36
25-S	M 36×2	24.5	33.84	46
30-S	M 42×2	29.5	39.84	50
38-S	M 52×2	37.5	49.84	60

Overview O-Lok® connections

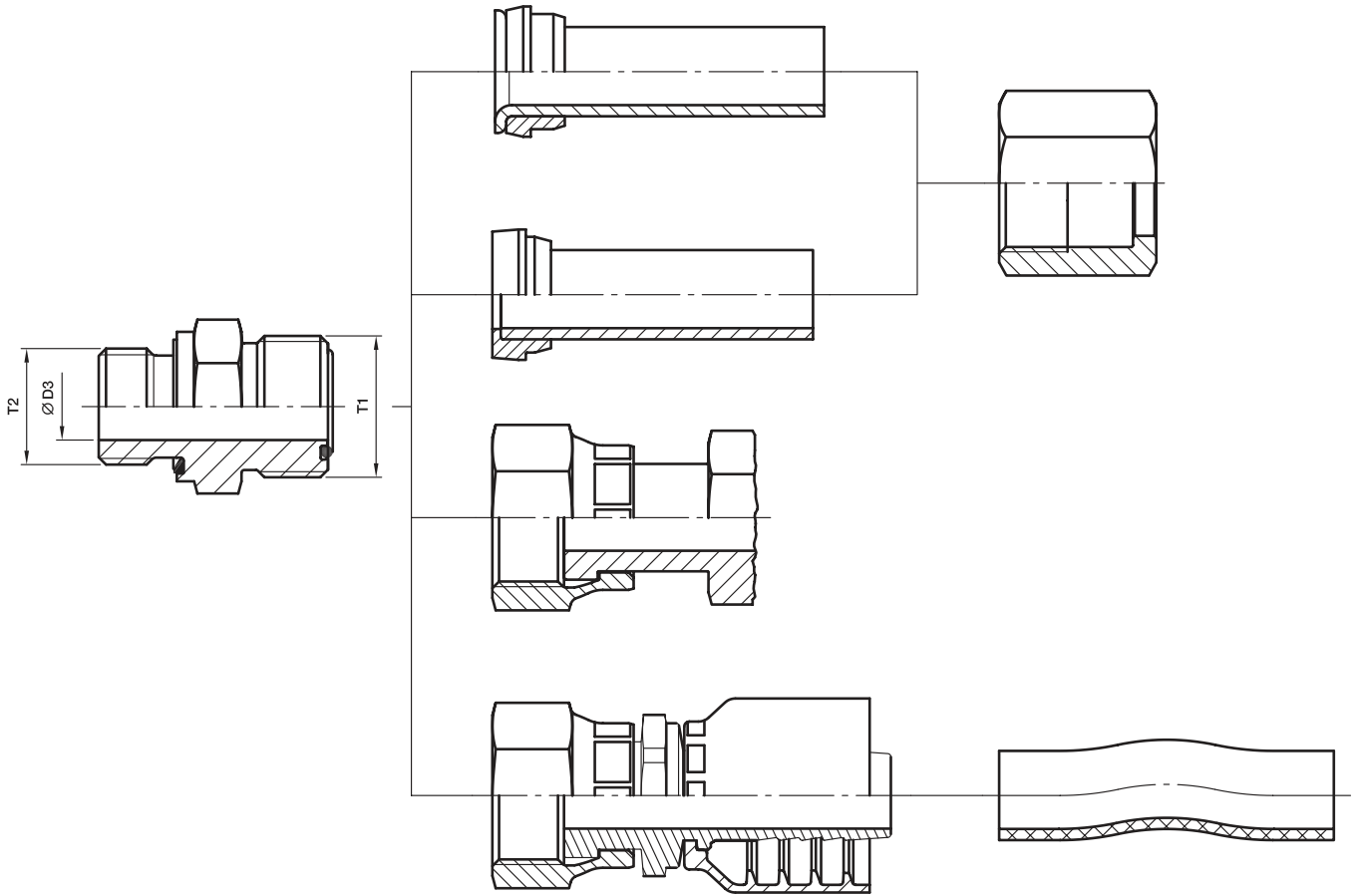

Overview O-Lok® connections

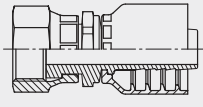
Size	Tube				T1 Thread UN/UNF	Ø D3 Bore diameter mm	T2 Port thread				
	Metric tube O.D. mm	Wall thickness mm	Inch tube O.D. inch	Wall thickness inch			BSP	UN/UNF	NPTF	metric	
4	6	1.5	1/4	0.065	9/16-18	4.0	G 1/8 A	7/16-20	1/8	M 12x1.5	1JCxx-4-yy
4-4	6	1.5	1/4	0.065		4.5	G 1/4 A		1/4		
4-6	6	1.5	1/4	0.065		4.5	G 3/8 A	9/16-18	3/8		
4-8	6	1.5	1/4	0.065		4.5	G 1/2 A	3/4-16			
6	8	2.0	5/16	0.095	1 1/16-16	6.5	G 1/4 A	9/16-18	1/4	M 16x1.5	1JCxx-6-yy
6	10	2.0	5/16	0.095	1 1/16-16	6.5	G 1/4 A	9/16-18	1/4	M 16x1.5	
6-2	10	2.0	5/16	0.095		4.5	G 1/8 A				
6-4	10	2.0	5/16	0.095		4.5		7/16-20			
6-6	10	2.0	5/16	0.095		6.5	G 3/8 A		3/8		
6-8	10	2.0	5/16	0.095		6.5	G 1/2 A	3/4-16	1/2		
6-10	10	2.0	5/16	0.095		6.5		7/8-14			
6-12	10	2.0	5/16	0.095	6.5	G 3/4 A					
8	12	3.0	1/2	0.095	1 3/16-16	9.5	G 3/8 A	3/4-16	3/8	M 18x1.5	1JCxx-8-yy
8-4	12	3.0	1/2	0.095		7.5	G 1/4 A				
8-6	12	3.0	1/2	0.095		9.5		9/16-18			
8-8	12	3.0	1/2	0.095		9.5	G 1/2 A	1/2			
8-10	12	3.0	1/2	0.095		9.5		7/8-14			
8-12	12	3.0	1/2	0.095		9.5	G 3/4 A	1 1/16-12	3/4		
8-16	12	3.0	1/2	0.095		9.5		1 5/16-12			
10	14	2.0				1-14	12.5	G 1/2 A	7/8-14		
10	15	2.0			1-14	12.5	G 1/2 A	7/8-14	1/2	M 22x1.5	1JCxx-10-yy
10	16	3.0	5/8	0.120	1-14	12.5	G 1/2 A	7/8-14	1/2	M 22x1.5	
10-6	16	3.0	5/8	0.120		10.0	G 3/8 A				
10-8	16	3.0	5/8	0.120		9.5		3/4-16			
10-12	16	3.0	5/8	0.120		12.5	G 3/4 A	1 1/16-12	3/4		
10-16	16	3.0	5/8	0.120		12.5	G 1 A				
12	18	2.0			1 3/16-12	15.5	G 3/4 A	1 1/16-12	3/4	M 27x2	1JCxx-20-yy
12	20	3.5	3/4	0.156	1 3/16-12	15.5	G 3/4 A	1 1/16-12	3/4	M 27x2	
12-8	20	3.5	3/4	0.156		9.5	G 1/2 A	3/4-16	1/2		
12-10	20	3.5	3/4	0.156		12.5		7/8-14			
12-16	20	3.5	3/4	0.156		12.5	G 1 A	1 5/16-12	1		
12-20	20	3.5	3/4	0.156		12.5	G 1 1/4 A				
16	22	2.5			1 7/16-12	20.5	G 1 A	1 5/16-12	1	M 33x2	1JCxx-16-yy
16	25	4.0	1	0.188	1 7/16-12	20.5	G 1 A	1 5/16-12	1	M 33x2	
16-12	25	4.0	1	0.188		15.5	G 3/4 A	1 1/16-12	3/4		
16-20	25	4.0	1	0.188		20.5	G 1 1/4 A	1 5/8-12			
16-24	25	4.0	1	0.188		20.5	G 1 1/2 A				
20	28	3.0			1 11/16-12	26.0	G 1 1/4 A	1 5/8-12	1 1/4	M 42x2	1JCxx-20-yy
20	30	4.0			1 11/16-12	26.0	G 1 1/4 A	1 5/8-12	1 1/4	M 42x2	
20	32	4.0	1 1/4	0.188	1 11/16-12	26.0	G 1 1/4 A	1 5/8-12	1 1/4	M 42x2	
20-16	32	4.0	1 1/4	0.188		21.5	G 1 A	1 5/16-12			
20-24	32	4.0	1 1/4	0.188		26.0	G 1 1/2 A	1 7/8-12			
24	35	3.0			2-12	32.0	G 1 1/2 A	1 7/8-12	1 1/2	M 48x2	1JCxx-24-yy
24	38	5.0	1 1/2	0.220	2-12	32.0	G 1 1/2 A	1 7/8-12	1 1/2	M 48x2	
24-20	38	5.0	1 1/2	0.220	27.5	G 1 1/4 A	1 5/8-12				
32	50	3.0	2	0.120	2 1/2-12	45.0	G 2A	2 1/2-12		M 60x2	—

xx - Fitting Series • yy - Hose Size
From Parker hose fitting (HPDE and PFDE)

Dimensioning

O-Lok® end (ISO 8434-3/SAE J1453)/dimensions

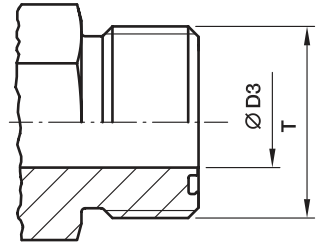

Size	Tube O.D.		T	T	Ø D3 mm
	inch	mm	UN/UNF	Major thread Ø mm	
4	1/4	6	9/16-18	14.0	5.0
6	5/16, 3/8	8, 10	1 1/16-16	17.0	6.5
8	1/2	12	1 3/16-16	20.5	9.5
10	5/8	14, 15, 16	1-14	25.0	12.5
12	3/4	18, 20	1 3/16-12	30.0	15.5
16	7/8, 1	22, 25	1 7/16-12	36.0	20.5
20	1 1/4	28, 30, 32	1 11/16-12	42.5	26.0
24	1 1/2	35, 38	2-12	50.5	32.0
32	2	50	2 1/2-12	63.0	45.0

All dimensions shown are nominal for identification only.

Small deviations may be found between SAE J1453 or ISO 8484-3 on bore sizes.

O-Lok[®] swivel connector (ISO 8434-3/SAE J1453)/dimensions

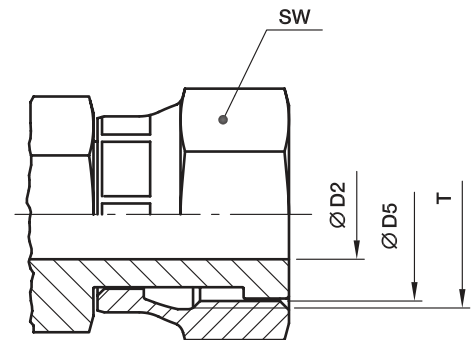

Size	Tube O.D.		T UN/UNF	Ø D5 Thread core diameter mm	SW mm	Ø D2 mm
	inch	mm				
4	1/4	6	9/16-18	12.5	17	4.0
6	5/16, 3/8	8, 10	1 1/16-16	16.0	22	6.5
8	1/2	12	1 3/16-16	19.0	24	9.0
10	5/8	14, 15, 16	1-14	23.0	30	11.5
12	3/4	18, 20	1 3/16-12	28.0	36	14.0
16	7/8, 1	22, 25	1 7/16-12	34.0	41	20.0
20	1 1/4	28, 30, 32	1 11/16-12	40.5	50	26.0
24	1 1/2	35, 38	2-12	48.0	60	32.0

All dimensions shown are nominal for identification only.

Small deviations may be found between SAE J1453 or ISO 8484-3 on bore sizes.

Overview Triple-Lok® connections

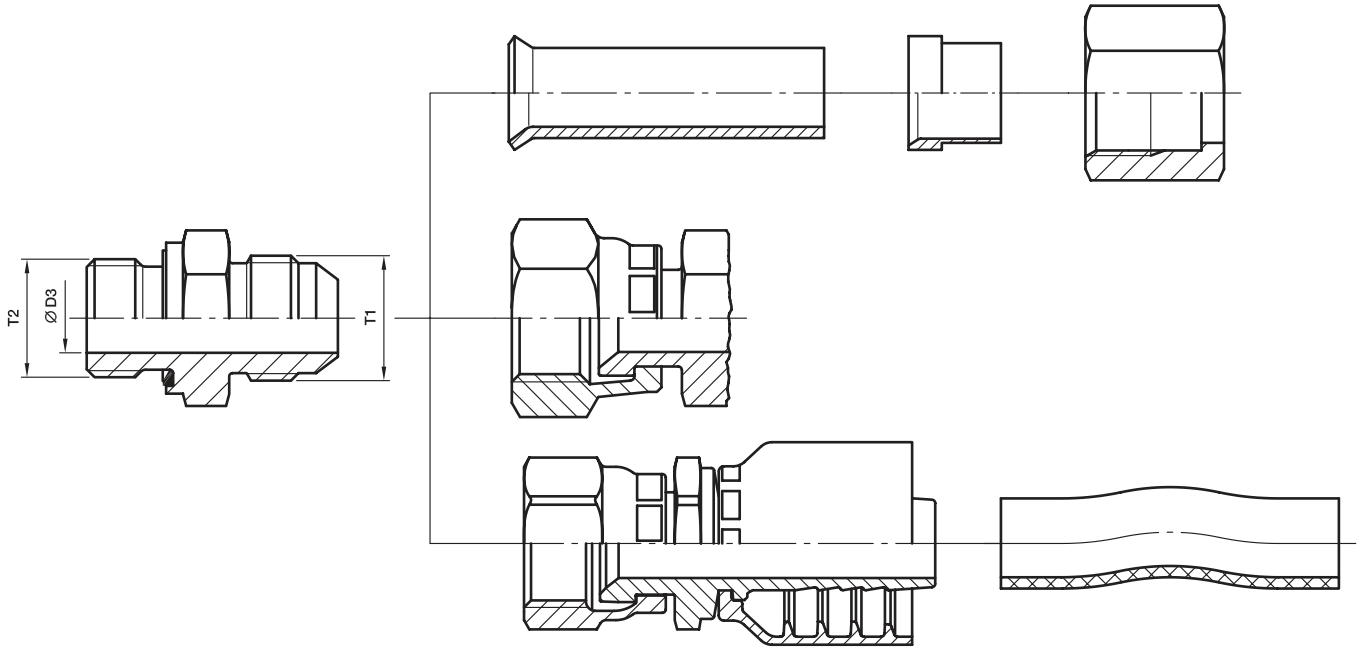

Overview Triple-Lok® connections

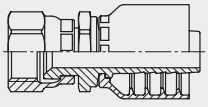
Size	Tube				T1 Thread UN/UNF	∅ D3 Bore diameter mm	T2 Port thread			
	Metric tube O.D. mm	Wall thickness mm	Inch tube O.D. inch	Wall thickness inch			BSPP (BSPT, NPTF)	UN/UNF	metric	
4	6	1.5	1/4	0.065	7/16-20	4.5	G 1/8 A	7/16-20	M 10×1.0	168xx-4-yy
4-4	6	1.5	1/4	0.065		4.5	G 1/4 A			
4-5	6	1.5	1/4	0.065		4.5		1/2-20		
4-6	6	1.5	1/4	0.065		4.5	G 3/8 A	9/16-18		
4-8	6	1.5	1/4	0.065		4.5	G 1/2 A			
5	8	1.5	5/16	0.065	1/2-20	6.0	G 1/8 A	1/2-20	M 12×1.5	168xx-5-yy
5-4	8	1.5	5/16	0.065		6.0	G 1/4 A			
5-6	8	1.5	5/16	0.065		6.0	G 3/8 A			
5-8	8	1.5	5/16	0.065		6.0	G 1/2 A			
6-2	10	1.5	3/8	0.065		9/16-18	7.5	G 1/8 A		
6	10	1.5	3/8	0.065	7.5		G 1/4 A	9/16-18		
6-6	10	1.5	3/8	0.065	7.5		G 3/8 A			
6-8	10	1.5	3/8	0.065	7.5		G 1/2 A	3/4-16		
8-4	12	2.0	1/2	0.083	3/4-16		10.0	G 1/4 A		M 16×1.5 M 18×1.5
8	12	2.0	1/2	0.083		10.0	G 3/8 A	3/4-16		
8-8	12	2.0	1/2	0.083		10.0	G 1/2 A			
8-10	12	2.0	1/2	0.083		10.0		7/8-14		
8-12	12	2.0	1/2	0.083		10.0	G 3/4 A	1 1/16-12		
10-6	14, 15, 16	2.5	5/8	0.095	7/8-14	12.5	G 3/8 A		M 18×1.5 M 22×1.5	168xx-10-yy
10-8	14, 15, 16	2.5	5/8	0.095		12.5		3/4-16		
10	14, 15, 16	2.5	5/8	0.095		12.5	G 1/2 A	7/8-14		
10-12	14, 15, 16	2.5	5/8	0.095		12.5	G 3/4 A	1 1/16-12		
12-8	18, 20	3.0	3/4	0.109		1 1/16-12	15.5	G 1/2 A		
12-10	18, 20	3.0	3/4	0.109	15.5			7/8-14		
12	18, 20	3.0	3/4	0.109	15.5		G 3/4 A	1 1/16-12		
12-16	18, 20	3.0	3/4	0.109	15.5		G 1 A	1 5/16-12		
14	22	3.0	7/8	0.109	1 3/16-12		18.0	G 3/4 A	1 3/16-12	M 27×2.0
14-16	22	3.0	7/8	0.109		18.0	G 1 A	1 5/16-12		
16-12	25	3.0	1	0.120	1 5/16-12	21.5	G 3/4 A	1 1/16-12	M 33×2.0	106xx-16-yy
16	25	3.0	1	0.120		21.5	G 1 A	1 5/16-12		
16-20	25	3.0	1	0.120		21.5	G 1 1/4 A	1 5/8-12		
20-12	28, 30, 32	3.0	1 1/4	0.120	1 5/8-12	27.5	G 3/4 A		M 42×2.0	106xx-20-yy
20-16	28, 30, 32	3.0	1 1/4	0.120		27.5	G 1 A			
20	28, 30, 32	3.0	1 1/4	0.120		27.5	G 1 1/4 A	1 5/8-12		
24-20	35, 38	4.0	1 1/2	0.120	1 7/8-12	33.0	G 1 1/4 A		M 48×2.0	106xx-24-yy
24	35, 38	4.0	1 1/2	0.120		33.0	G 1 1/2 A	1 7/8-12		
28-24	42	3.0			2 1/4-12	39.0	G 1 1/2 A			—
32	50	3.5	2	0.134	2 1/2-12	45.0	G 2 A	2 1/2-12		106xx-32-yy

xx - Fitting Series • yy - Hose Size
From Parker hose fitting
(HPDE and PFDE)

Triple-Lok® end (ISO 8434-2/SAE J1514)/dimensions

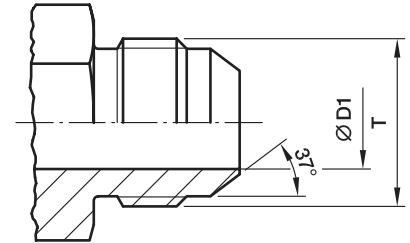

Size	Tube O.D.		T UN/UNF	T Major thread Ø mm	Ø D1 mm
	inch	mm			
4	1/4	6	7/16-20	11.0	4.5
5	5/16	8	1/2-20	12.5	6.0
6	3/8	10	9/16-18	14.0	7.5
8	1/2	12	3/4-16	19.0	10.0
10	5/8	14, 15, 16	7/8-14	22.0	12.5
12	3/4	18, 20	1 1/16-12	27.0	15.5
14	7/8	22	1 3/16-12	30.0	18.0
16	1	25	1 5/16-12	33.0	21.5
20	1 1/4	28, 30, 32	1 5/8-12	41.0	27.5
24	1 1/2	35, 38	1 7/8-12	47.5	33.0
28*	1 3/4	42	2 1/4-12	57.0	39.0
32	2	—	2 1/2-12	63.5	45.0

*Size 28 is not part of SAE J 1514 or ISO 8434-2.

All dimensions shown are nominal for identification only.

Small deviations may be found between SAE J1453 or ISO 8484-3 on bore sizes.

Suitable Flare

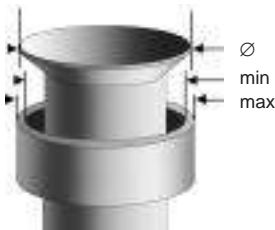

Tube O.D.		Ø D	
mm	inch	Min.	Max.
6	1/4"	8.0	9.7
8	5/16"	9.5	1.3
10	3/8"	11.2	12.7
12	1/2"	14.9	17.3
14		17.9	20.2
15		17.9	20.2
16	5/8"	17.9	20.2
18		22.3	24.7
20	3/4"	22.3	24.7
22	7/8"	25.5	27.8
25	1"	28.7	31.0
28		35.8	38.9
30		35.8	38.9
32	1.1/4"	35.8	38.9
35		41.4	45.3
38	1.1/2"	41.4	45.3
42		50.9	54.8
	2"	55.8	61.2

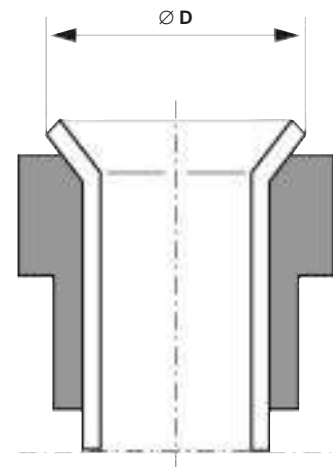

37°-Flare acc. ISO 8434-2 not compatible with Flare according DIN 3949.

Triple-Lok® swivel connector (ISO 8434-3/SAE J514)/dimensions

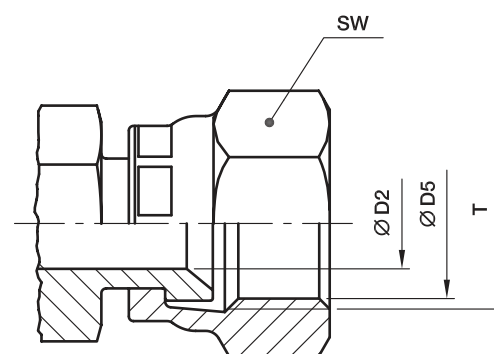

Size	Tube O.D.		T UN/UNF	SW mm	Ø D5 Thread core diameter mm	Ø D2 mm
	Inch	mm				
4	1/4	6	7/16-20	17	10.0	4.4
5	5/16	8	1/2-20	17	11.5	6.0
6	3/8	10	9/16-18	19	13.0	7.5
8	1/2	12	3/4-16	22	17.5	9.9
10	5/8	14, 15, 16	7/8-14	27	20.5	12.3
12	3/4	18, 20	1 1/16-12	32	25.0	15.5
14	7/8	22	1 3/16-12	35	28.0	18.0
16	1	25	1 5/16-12	38	31.0	21.5
20	1 1/4	28, 30, 32	1 5/8-12	50	39.0	27.5
24	1 1/2	35, 38	1 7/8-12	60	45.5	33.0
32	2	—	2 1/2-12	75	61.5	45.0

All dimensions shown are nominal for identification only.

Small deviations may be found between SAE J1453 or ISO 8484-3 on bore sizes.

Dimensioning

DIN 60° cone end (DIN 7631)/dimensions

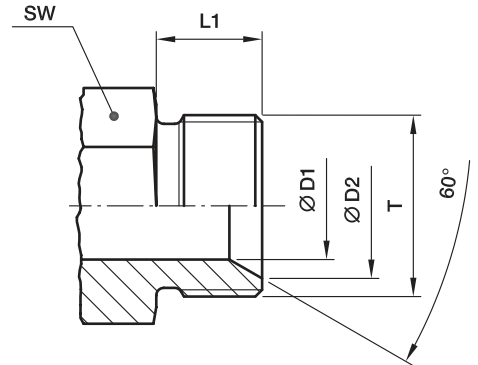

Tube O.D. mm	T	Ø D1 mm	Ø D2 mm	L1 mm	SW mm
4-5	M 10×1.5	3	8.0	8	11
06	M 12×1.5	4	9.0	10	12
08	M 14×1.5	6	11.0	10	14
10	M 16×1.5	8	13.0	11	17
12	M 18×1.5	10	15.0	11	19
15	M 22×1.5	12	19.0	12	24
18	M 26×1.5	15	22.0	12	27
22	M 30×1.5	19	26.0	14	32
28	M 38×1.5	25	33.0	14	41
35	M 45×1.5	32	40.0	16	46
42	M 52×1.5	39	47.0	16	55

Adapter 60° cone end (ISO/DIS 8434-6)/dimensions

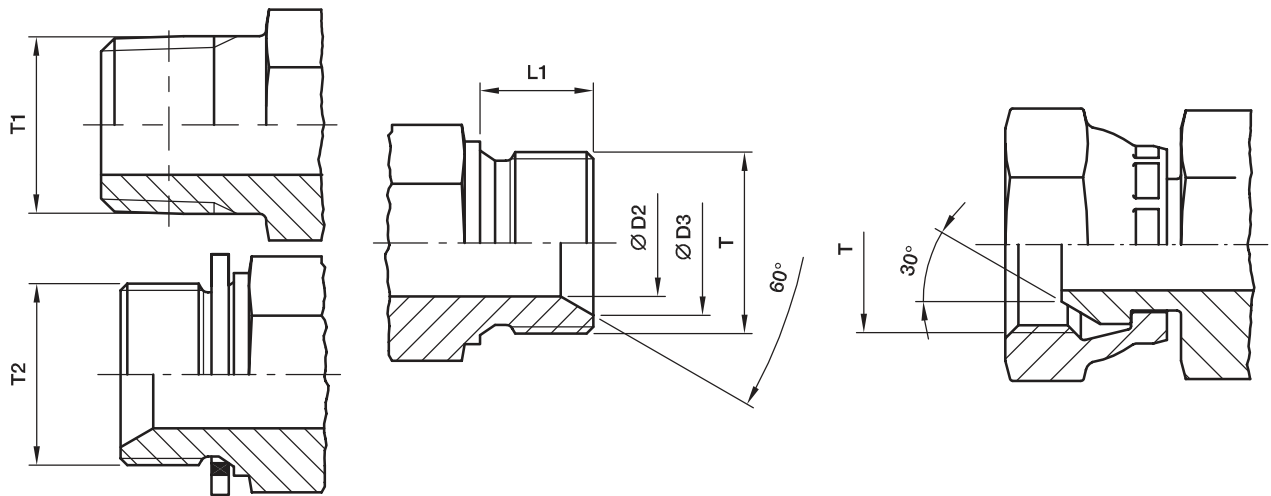

Size	T BSPP	D2 mm	D3 mm	L1 mm	T1		T2 BSPP
					BSPT	NPT(F)	
02	G 1/8 A	3.5	7.5	8	1/8	1/8	1/8
					1/4	1/4	
04	G 1/4 A	4.7	10.4	11	1/4	1/4	1/4
					1/8	1/8	
					3/8	3/8	
06	G 3/8 A	7.9	14.0	12	3/8	3/8	3/8
					1/4	1/4	
					1/2	1/2	
08	G 1/2 A	11.1	17.5	14	1/2	1/2	1/2
					3/8	3/8	
						3/4	
10	G 5/8 A	14.3	19.3	16	1/2		1/2
					3/4		
12	G 3/4 A	16.7	22.9	16	3/4	3/4	3/4
					1/2	1/2	
					1	1	
16	G 1 A	22.2	28.7	19	1	1	1
					3/4	3/4	
20	G 1 1/4 A	28.6	36.8	22	1 1/4		3/4
24	G 1 1/2 A	33.3	42.7	22	1 1/2		1
32	G 2 A	46.0	54.6	25			1 1/2

NPSM Swivel adapters (SAE J516)/dimensions

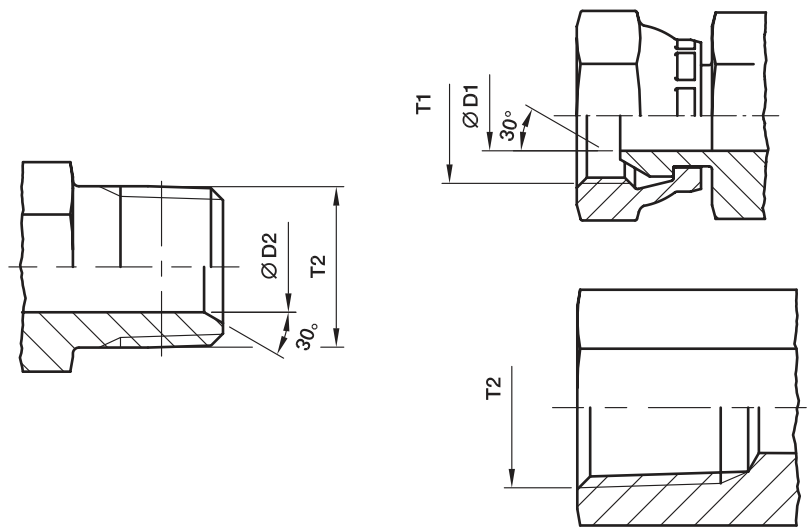

Size	T1 Thread NPSM	Ø D1 mm	Ø D2 mm	T2 Thread NPTF
2-2	1/8-27	4.0	5.0	1/8-27
2-4	1/4-18	5.6	7.0	1/8-27
4-4	1/4-18	5.6	7.0	1/4-18
4-6	3/8-18	8.8	10.0	1/4-18
4-8	1/2-14	12.0	13.5	1/4-18
6-4	1/4-18	5.6	7.0	3/8-18
6-6	3/8-18	8.8	10.0	3/8-18
6-8	1/2-14	12.0	13.5	3/8-18
8-4	1/4-18	5.6	7.0	3/4-16
8-6	3/8-18	8.8	10.0	1/2-14
8-8	1/2-14	12.0	13.5	1/2-14
8-12	3/4-14	16.3	18.0	1/2-14
10-6	3/8-18	8.8	10.0	7/8-14
10-8	1/2-14	12.0	13.5	7/8-14
10-12	3/4-14	16.3	18.0	7/8-14
12-6	3/8-18	8.8	10.0	3/4-14
12-8	1/2-14	12.0	13.5	3/4-14
12-12	3/4-14	16.3	18.0	3/4-14
12-16	1-11 1/2	21.4	28.9	
16-12	3/4-14	16.3	13.5	1-11 1/2
16-16	1-11 1/2	21.4	28.9	1-11 1/2
16-20	1 1/4-11 1/2	29.0	32.0	1-11 1/2
20-16	1-11 1/2	21.4	28.9	1 1/4-11 1/2
20-20	1 1/4-11 1/2	29.0	32.0	1 1/4-11 1/2
24-24	1 1/2-11 1/2	34.5	38.0	1 1/2-11 1/2
32-32	2-11 1/2	46.0	49.0	2-11 1/2

Male stud ends/Port end dimensions for tube fittings

Preferred male stud ends for hydraulic applications

For reconstructions the metric version is recommended according to ISO 6149

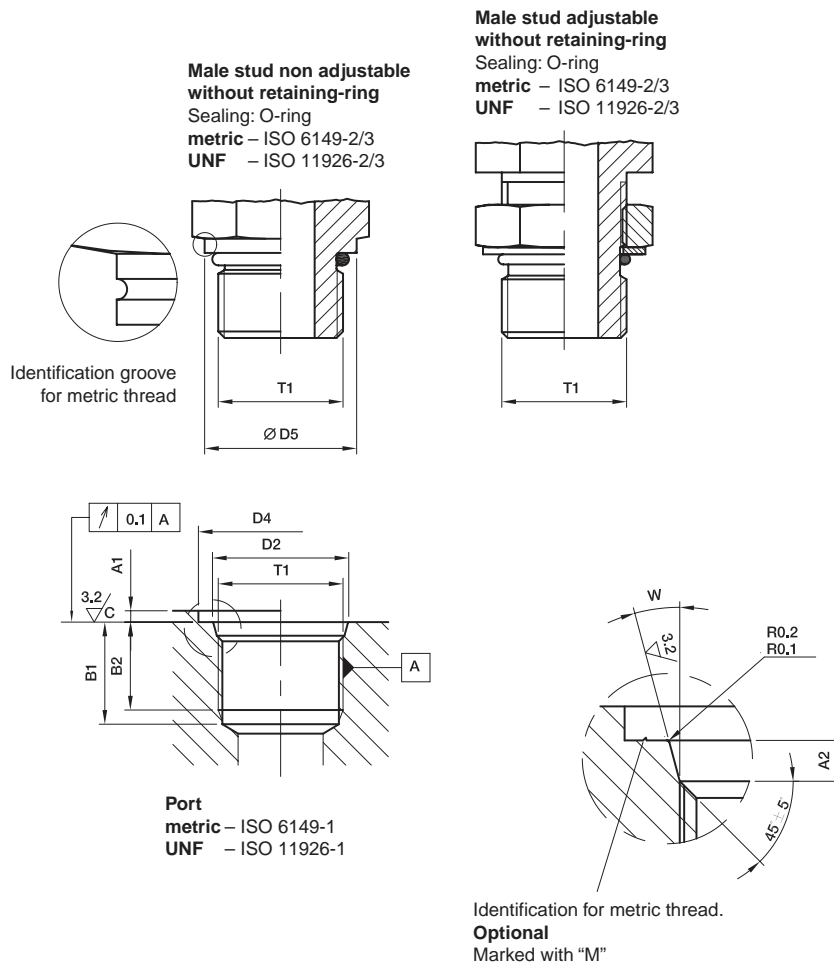

Thread T1	D5	D4.1 min.	D4.2 min.	D2 0.1	A1 max.	A2 0.4	B1 min.	B2 min.	W ± 1°	Identification internal	
										Thread minor diameter	Thread minor diameter
M 8×1	11.8	14	17	9.10	1.0	1.6	11.5	10.0	12°	8.00	6.92
M 10×1	13.8	16	20	11.10	1.0	1.6	11.5	10.0	12°	10.00	8.92
M 12×1.5	16.8	19	23	13.80	1.5	2.4	14.0	11.5	15°	12.00	10.38
M 14×1.5	18.8	21	25	15.80	1.5	2.4	14.0	11.5	15°	14.00	12.38
M 16×1.5	21.8	24	28	17.80	1.5	2.4	15.5	13.0	15°	16.00	14.38
M 18×1.5	23.8	26	30	19.80	2.0	2.4	17.0	14.5	15°	18.00	16.38
M 22×1.5	26.8	29	34	23.80	2.0	2.4	18.0	15.5	15°	22.00	20.38
M 27×2	31.8	34	40	29.40	2.0	3.1	22.0	19.0	15°	27.00	24.84
M 33×2	40.8	43	49	35.40	2.5	3.1	22.0	19.0	15°	33.00	30.84
M 42×2	49.8	52	60	44.40	2.5	3.1	22.5	19.5	15°	42.00	39.84
M 48×2	54.8	57	66	50.40	2.5	3.1	25.0	22.0	15°	48.00	45.84
7/16-20 UNF-2B	13.8	21	—	12.40	1.6	2.4	14.0	11.5	12°	11.11	9.74
9/16-18 UNF-2B	16.8	25	—	15.65	1.6	2.5	15.5	12.7	12°	14.29	12.76
3/4-16 UNF-2B	21.8	30	—	20.60	2.4	2.5	17.5	14.3	15°	19.05	17.33
7/8-14 UNF-2B	26.8	34	—	23.95	2.4	2.5	20.0	16.7	15°	22.23	20.26
1 1/16-12 UN-2B	31.8	41	—	29.15	2.4	3.3	23.0	19.0	15°	26.99	24.69
1 5/16-12 UN-2B	40.8	49	—	35.50	3.2	3.3	23.0	19.0	15°	33.34	31.04
1 5/8-12 UN-2B	49.8	58	—	43.50	3.2	3.3	23.0	19.0	15°	41.28	38.99
1 7/8-12 UN-2B	54.8	65	—	49.85	3.2	3.3	23.0	19.0	15°	47.63	45.33

Port end dimensions for tube fittings

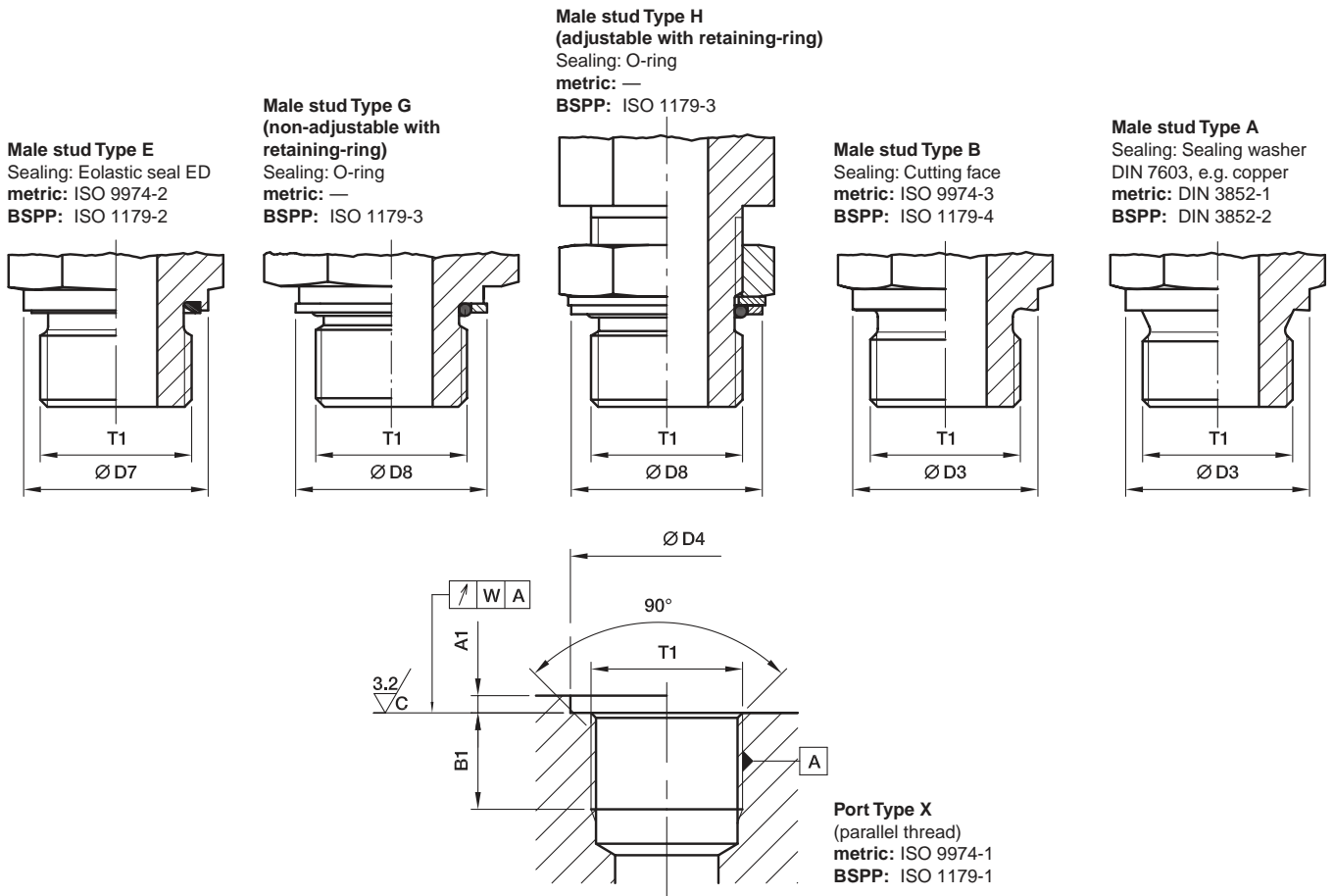

Thread T1	Ø D3 mm	Ø D7 mm	D8		D4 min. small	D4 ^{+0.4} wide	A1 max.	B1 min.	W	Identification internal	
			small	wide						Thread major diameter	Thread minor diameter
M 8×1			12.8	13.15					0.1	8.00	6.92
M 10×1	13.9	13.9	14.8	14.75	15	20	1.0	8	0.1	10.00	8.92
M 12×1.5	16.9	16.9	17.8	17.75	18	25	1.5	12	0.1	12.00	10.38
M 14×1.5	18.9	18.9	19.8	19.75	20	25	1.5	12	0.1	14.00	12.38
M 16×1.5	20.9	21.9	22.8	21.75	23	28	1.5	12	0.1	16.00	14.38
M 18×1.5	22.9	23.9	24.8	23.75	25	30	2.0	12	0.1	18.00	16.38
M 20×1.5	24.9	25.9	26.8	25.75	27	34	2.0	14	0.1	20.00	18.38
M 22×1.5	26.9	26.9	27.8	27.75	28	34	2.5	14	0.1	22.00	20.38
M 26×1.5	30.9	31.9	32.8	31.75	33	42	2.5	16	0.2	26.00	24.38
M 27×2	31.9	31.9	32.8	32.75	33	42	2.5	16	0.2	27.00	24.84
M 33×2	38.9	39.9	40.8	39.75	41	47	2.5	18	0.2	33.00	30.84
M 42×2	48.9	49.9	50.8	49.75	51	58	2.5	20	0.2	42.00	39.84
M 48×2	54.9	54.9	55.8	54.95	56	65	2.5	22	0.2	48.00	45.84
G 1/8 A	13.8	13.9	14.8	15.00	15	19	1.0	8	0.1	9.73	8.57
G 1/4 A	17.8	18.9	19.8	19.5	20	25	1.5	12	0.1	13.16	11.45
G 3/8 A	21.8	21.9	22.8	23.5	23	28	2.0	12	0.1	16.66	14.95
G 1/2 A	25.8	26.9	27.8	28.5	28	34	2.5	14	0.1	20.96	18.63
G 3/4 A	31.8	31.9	32.8	34.5	33	42	2.5	16	0.2	26.44	24.12
G 1 A	38.8	39.9	40.8	43.5	41	47	2.5	18	0.2	33.25	30.29
G 1 1/4 A	48.8	49.9	50.8	52.5	51	58	2.5	20	0.2	41.91	38.95
G 1 1/2 A	54.8	54.9	55.8	60.00	56	65	2.5	22	0.2	47.80	44.85

Port end dimensions for tube fittings

Male stud NPT/F
Sealing: Tapered thread¹⁾
NPT ANSI/ASME B 1.20.1-1983
NPTF ANSI/ASME B 1.20.3-1976

Male stud BSPT
Sealing: Tapered thread¹⁾
ISO 7/BS 21/DIN 2999-1

Male stud Type C
Sealing: Tapered thread short¹⁾
metric DIN 3852-1
Inch DIN 3852-2

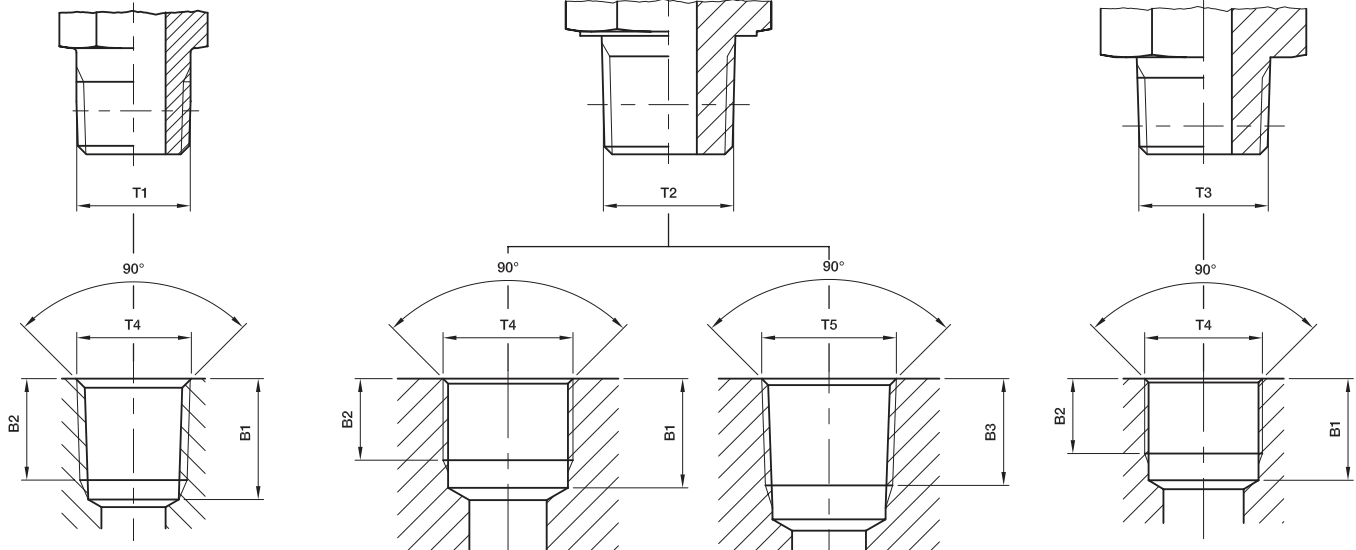

Port NPT/F (taper)
NPT ANSI/ASME B 1.20.1-1983
NPTF ANSI/ASME B 1.20.3-1976

Port BSPP (parallel)
ISO 7/1-Rp
BS 21-Rp (ISO 1179-1)

Port BSPT (taper)
ISO 7/1-Rc/BS 21-Rc
DIN 2999-Rc (Japan: PT)

Port (parallel)
metric DIN 3852-1
Inch DIN 3852-2

Thread T1	Thread T2	Thread T3	Thread T4	Thread T5	B1 min.	B2 min.	B3 min.
1/8-27 NPT/F* 1/4-18 NPT/F* 3/8-18 NPT/F* 1/2-14 NPT/F* 3/4-14 NPT/F* 1-11.5 NPT/F* 1 1/4-11.5 NPT/F* 1 1/2-11.5 NPT/F*			1/8-27 NPT/F* 1/4-18 NPT/F* 3/8-18 NPT/F* 1/2-14 NPT/F* 3/4-14 NPT/F* 1-11.5 NPT/F* 1 1/4-11.5 NPT/F* 1 1/2-11.5 NPT/F*		11.6 16.4 17.4 22.6 23.1 27.8 28.3 28.3	6.9 10.0 10.3 13.6 14.1 16.8 17.3 17.3	
	R 1/8 R 1/4 R 3/8 R 1/2 R 3/4 R 1 R 1 1/4 R 1 1/2		Rp 1/8 Rp 1/4 Rp 3/8 Rp 1/2 Rp 3/4 Rp 1 Rp 1 1/4 Rp 1 1/2	Rc 1/8 Rc 1/4 Rc 3/8 Rc 1/2 Rc 3/4 Rc 1 Rc 1 1/4 Rc 1 1/2	9.7 12.0 13.5 17.6 19.1 21.4 21.4 22.4	7.9 11.2 12.0 15.0 16.0 19.1 19.9 20.6	7.4 11.0 11.4 15.0 16.3 19.0 21.4 21.4
		M 8×1 tap. M 10×1 tap. M 12×1.5 tap. M 14×1.5 tap. M 16×1.5 tap. M 18×1.5 tap. M 20×1.5 tap. M 22×1.5 tap.	M 8×1 M 10×1 M 12×1.5 M 14×1.5 M 16×1.5 M 18×1.5 M 20×1.5 M 22×1.5		10.0 10.0 13.5 13.5 13.5 13.5 15.5 15.5	5.5 5.5 8.5 8.5 8.5 8.5 10.5 10.5	
		R 1/8 tap. R 1/4 tap. R 3/8 tap. R 1/2 tap.	Rp 1/8 Rp 1/4 Rp 3/8 Rp 1/2		8.5 12.5 12.5 16.5	5.5 8.5 8.5 10.5	

*In the EO fitting range only NPT thread is manufactured.

In the Triple-Lok®, O-Lok® and adapters fitting range for steel NPTF thread is manufactured and for stainless steel NPT thread is manufactured.

1)Tightness can only be achieved by liquid or plastic sealing aids.



Tube assembly



Table of contents

Safety instructions	E4
General	E5
Selection of assembly process	E6
EO Progressive Stop Ring PSR assembly instructions	E8
EO Progressive Ring DPR assembly instructions	E12
EO-2 assembly instructions	E16
Checking instructions for EO assembly tools	E20
EO2-FORM assembly instructions	E21
Checking instructions for EO2-FORM tools	E26
Weld fitting assembly	E27
O-Lok® assembly instructions	E28
Triple-Lok® assembly instructions	E32
Checking instructions for O-Lok® / Triple-Lok®	E35
Flange-Seal assembly instructions	E36



Safety instructions

Tube fittings are safe high-pressure connections



A carefully assembled Parker tube fitting will provide a sealed joint even up to tube burst. Experience has shown that break-downs, re-tightening and leaks can be avoided by following these safety instructions. Please review your fitting procedures.

General safety instructions

- Uncomplete assembly will reduce the pressure and vibration capability of a fitting. It can reduce the life cycle time of a connection and leakage can occur. In extreme cases the connection can fail due to tube shear or tube crack.
- After opening a tube connection, the unit has to be retightened with the same force used during prior assembly. Undertightening can result in leakage and can reduce the vibration resistance. Overtightening can reduce the possibilities of repeated assembly. In extreme cases the components can be destroyed.
- Parker tube fittings are intended solely for connections for fluid applications.
- Observe tube recommendations. Non-standard materials or tolerances lead to incorrect assembly.
- Do not use ball bearings, fitting pins or tapered pins, coins or washers instead of the correct Parker blanking plug as blanking parts for 24° cones.
- Tube connection and fitting body once assembled, should remain together. Fitting body is to be used once only for pre-assembly.
- Air bleeding of tube fittings which are under pressure can be dangerous.
- Tube under tension can lead to vibration failure. Tube length and bend angles are to be adhered to precisely. Fix tube lines with tube clamps.
- Tubes are not to be clamped to one another but to suitable fixed points. Plate brackets, cable connections and fixing elements are not suitable. Tubes are not mountings on which to integrate other components e.g. filters, ventilators or shut-off valves.
- Prevent oscillation, pressure surges and inherent strain by using flexible hoses for example.
- Under and overtightening of fittings during assembly reduces the capacity for withstanding pressure and vibration loads and therefore reduces the life of the tube fitting. Leaks from the tube can occur under these circumstances.
- When dismantling/transporting and re-assembling, make sure that no dirt enters the system, that the connection elements (threads, sealing surfaces) are not damaged, seals are not lost and tubes are not bent or flattened. We recommend the use of suitable protective caps.
- Disassembled fittings are to be checked for accuracy and damage and replaced if necessary.
- Do not use hand cutters or tube cutters.

- Dirt and metal contamination can lead to damage to the system and leaks.
- The operating parameters given (e.g. pressure, temperature, medium compatibility) are to be adhered to.
- Avoid flow rates > 8 m/s. The resulting forces are high and can destroy the tube lines.
- Relevant guidelines (e.g. CE, ISO, BG, TÜV, DIN) are to be observed.
- Weld fittings are manufactured out of weldable materials. No other fittings are suitable for welding.
- EO-Niromont and Parflange 1040LUBSS are high-performance lubricants. The use of other lubricants generally leads to an increase in assembly force.
- The tools and lubricants recommended by Parker guarantee safe assembly.
- Components and tooling of different manufacturers are not necessarily compatible. For complete safety, use only Parker components.
- Fittings are to be handled with care.
- Tubelines need to be adapted tension free of the relevant connectors before assembly. An easy turning of the nut is required for the complete thread length. Otherwise leakage can occur. In extreme cases with additional vibrations tube cracks can occur.
- Vibrations have to be clamped by tube clamps. Independent vibrating units need to be separated with hoses. Otherwise tube cracks can occur.

Specific safety instructions for assembly

- During a progressive ring and EO-2 fitting assembly the tube has to bottom up in the stud or in the tool. Without tube bottoming the ring cannot bite sufficiently. Under load the connection can fail due to tube shear.
- Correctly flared tubes are essential for leak free performance of Triple-Lok® fittings. Special care must be taken over the flare diameter and surface finish.
- Preset bite type fittings (PSR / DPR) need a final assembly according to assembly instructions.
- Stainless steel progressive ring fittings have to be preassembled in hardened tools. Otherwise the connection may fail under load due to tube shear.
- Do not assemble progressive rings and functional nuts on self-made standpipe stud ends. There is a risk of false assembly with the result of connection shear under load.
- The use of steel cutting rings for stainless steel tubes or other unauthorised tool combinations leads to incorrect assembly.

In case of doubt please contact your Parker representative!

General

Assembly of Parker tube fittings always follows the same pattern:



Material combinations

- Use recommended tube material
- Select suitable components according to tube material

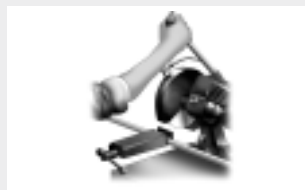

Tube preparation

- Cut and deburr thoroughly
- Follow recommendations for minimum straight tube length
- Apply support sleeves when necessary

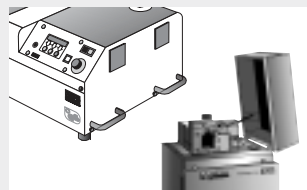

Machine assembly

- Preferred and most efficient method
- Recommended for large O.D. (30mm+) EO/EO2-fittings
- Parflange® recommended for 37° flaring



Manual assembly

- Economical for assembly of small quantities
- Suitable for small O.D. tube
- For repair work
- Hand flaring does not provide reliable results



Assembly check

- Check assembly tube preparation result
- ⚠ Incorrect assemblies must be corrected or scrapped













Final installation













- Final fitting assembly according to instruction
- Do not assemble under tension
- Clamp onto rigid fixtures
- Tighten tube clamps after final fitting installation



Tube assembly









Selection of assembly process for bite systems



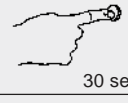

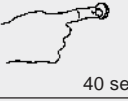



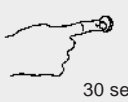

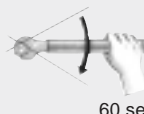
Manual assembly for field repair					
Process			Product		
Procedure	Equipment	Process / Time*	DPR	PSR	EO2
Pre-assembly using EOMAT II machine		 30 sec.	ideal for workshop assembly	ideal for workshop assembly	ideal for workshop assembly
Pre-assembly using EOMAT III machine		 30 sec.	ideal for serial production	ideal for serial production	ideal for serial production
Tube forming using EO2-FORM F2 machine		 40 sec.	not applicable	not applicable	not applicable
Tube flaring using Parflange® 1025 machine		 45 sec.	not applicable	not applicable	not applicable
Tube flaring using Parflange® 1040 machine		 30 sec.	not applicable	not applicable	not applicable

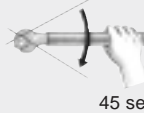
Workshop machines for industrial assembly					
Process			Product		
Procedure	Equipment	Process/Time*	DPR	PSR	EO2
Direct in fitting		 60 sec.	field repair only not for efficient production and tubes larger than 22mm OD not for stainless steel	field repair only not for efficient production and tubes larger than 22mm OD preferred method for PSR not for stainless steel	field repair only not for efficient production and tubes larger than 22mm OD
Pre-assembly in vice		 45 sec.	field repair only not for efficient production	field repair only not for efficient production	field repair only not for efficient production
Flaring in vice		 120 sec.	not applicable	not applicable	not applicable
Pre-assembly using HVM-B device		 30 sec.	final assembly in fitting must be 1/2 turn not for tubes larger than 15mm OD not for stainless steel	final assembly in fitting must be 1/2 turn not for tubes larger than 15mm OD not for stainless steel	not applicable
Pre-assembly using EO-KARRYMAT		 60 sec.	ideal for repair jobs and small on-site installations not suitable for industrial production	ideal for repair jobs and small on-site installations not suitable for industrial production	ideal for repair jobs and small on-site installations not suitable for industrial production
Tube flaring using 1015 device		 60 sec.	not applicable	not applicable	not applicable

*Average for total assembly time of medium size fitting including assembly check and final tightening

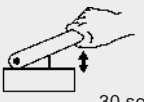
Selection of assembly process for tube forming systems

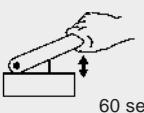
Manual assembly for field repair					
Procedure	Process		Product		
	Equipment	Process / Time*	EO2-FORM	Triple-Lok®	O-Lok®
Pre-assembly using EOMAT II machine		 30 sec.	not applicable	suitable for workshop assembly preferred process is Parflange	not applicable
Pre-assembly using EOMAT III machine		 30 sec.	not applicable	suitable for workshop assembly preferred process is Parflange	not applicable
Tube forming using EO2-FORM F2 machine		 40 sec.	ideal for workshop assembly and serial production	not applicable	not applicable
Tube flaring using Parflange® 1025 machine		 45 sec.	not applicable	ideal for workshop assembly not recommended for mass production not suitable for assembly of SS tubes over 25mm	ideal for workshop assembly not recommended for mass production not suitable for assembly of SS tubes over 25mm
Tube flaring using Parflange® 1040 machine		 30 sec.	not applicable	ideal for workshop assembly and serial production	ideal for workshop assembly and serial production automatic sleeve feeder available for mass production

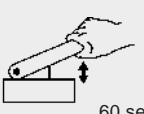
Workshop machines for industrial assembly					
Procedure	Process		Product		
	Equipment	Process/Time*	EO2-FORM	Triple-Lok®	O-Lok®
Direct in fitting		 60 sec.	not possible use EO2 for field repair	not possible use 1015 device or hand flaring tools for field repair	not possible use braze sleeves for field repair
Pre-assembly in vice		 45 sec.	not possible use EO2 for field repair	not possible use 1015 device or hand flaring tools for field repair	not possible use braze sleeves for field repair
Flaring in vice		 120 sec.	not applicable	field repair only not for efficient production not for stainless steel tubes	not possible use braze sleeves for field repair
Pre-assembly using HVM-B device		 30 sec.	not applicable	not applicable	not applicable
Pre-assembly using EO-KARRYMAT		 60 sec.	not possible use EO2 for field repair	not applicable	not applicable
Tube flaring using 1015 device		 60 sec.	not possible use EO2 for field repair	ideal for repair jobs and small on-site installations not suitable for industrial production	not applicable

*Average for total assembly time of medium size fitting including assembly check and final tightening



EO-Progressiv Stop Ring PSR assembly instructions

Only for New Generation PSR fittings

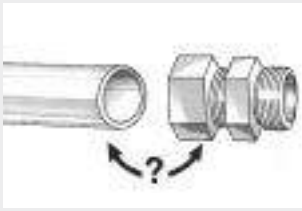

Material combinations

- Select suitable EO Progressive Stop Ring PSR fitting

Tube material	EO Progressive Stop Ring PSR material	EO fitting material	Assembly instructions
Steel	Steel	Steel	
Plastic e.g. Polyamide	Steel	Steel	Support sleeve E required



Tube preparation

- Cut and deburr thoroughly
- Do not assemble under tension
- Clamp onto rigid fixtures



1

- Cut tube squarely
- max $\pm 1^\circ$ deviation
- ⚠ Do not use pipe cutters
- EO tube-cutting tool (AV) for manual cutting



2

- Minimum lengths of straight tube-ends, $H=2 \times$ nut length
- Use swivel union "GZ" instead of short tubes



3

- Remove internal and external burrs
- max. chamfer 0.3mm x 45°
- Recommendation: In-Ex Tube Deburring Tool 226



Support sleeves VH

- Support sleeve VH for thin wall or soft metal tubes
- See catalogue assembly instruction booklet for VH application



Tube insert E

- Support sleeve E for plastic tubes



1

- Insert support sleeve like shown



2

- Drive VH into tube-end

VH selection chart for EO Progressive Stop Ring PSR

For steel tubes material ST 37.4

Wall thickness	4	5	6	8	10	12	14	15	16	18	20	22	25	28	30	35	38	42
3																	●	●
2.5																	●	●
2																	●	●
1.5																	●	●
1																	●	●
0.75			●															

- Support sleeve required
- Support sleeve required for heavily loaded lines (vibrations)

EO Progressive Stop Ring PSR assembly instructions

Only for New Generation PSR fittings

100% Pre-assembly with Eomat/EO-Karrymat

- Preferred and
- Most efficient method
- ⚠ HVMB-device not suitable for 100% assembly of PSR fittings



EOMAT II



EOMAT III/A



EO-KARRYMAT

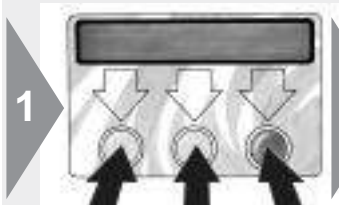

1

- EOMAT II: Adjustment according to pressure chart on machine (PSR)
- EOMAT III/A: Menu selection (PSR)
- EO-KARRYMAT: Refer to chart on machine (PSR)
- Non-EOMAT-machines: Check suitability



2

- The assembly cones (MOK) must be checked regularly (after 50 pre-assemblies) with cone gauges (KONU)
- The rear of the gauge must protrude slightly above the top face of the cone or may be flush
- Check insertion depth according to MOK checking instructions



3

- Insert proper tools
- Clean and lubricate assembly cones regularly
- EO-KARRYMAT: Close valve on handpump
- 2-piece backing plates for 35-L and 42-L



4

- Slide nut and progressive stop ring PSR as shown onto the end of the tube

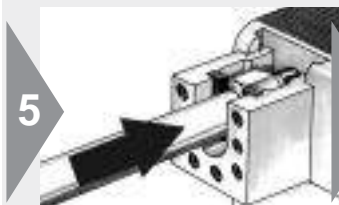

5

- Place tube with progressive stop ring PSR and nut into the die
- Press tube-end firmly into the assembly cone



6

- Hold tube firmly
- EOMAT: Press and hold start button
- Use support and foot switch for long tubes
- EO-KARRYMAT: Operate handpump until assembly pressure is reached



7

- After completion of pre-assembly, remove the tube for assembly check
- EO-KARRYMAT: Open valve on handpump



8

- ⚠ Check to make sure that a visible collar covers the front of the first cutting edge
- It does not matter if the ring can be rotated on the tube-end

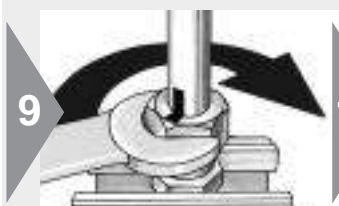

9

- Assemble fitting until wrench-tight (without spanner extension)
- ⚠ Mark position of nut

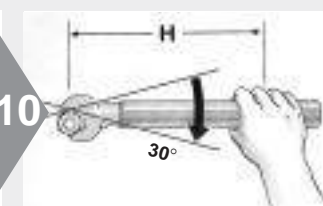

10

- ⚠ Then tighten fitting firmly by 30° (1/2 flat)
- ⚠ Recommended to use spanner extension for sizes over 20 mm O.D. (see chart)
- Assembly torques are available on request

Spanner length

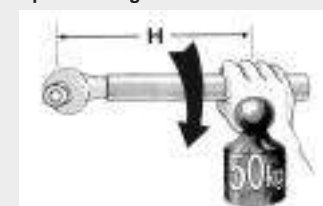

Size	Spanner length H [mm]
22-L	400
28-L 20-S	500
35-L 25-S	800
42-L 30-S	1000
38-S	1200



EO Progressive Stop Ring PSR assembly instructions

Only for New Generation PSR fittings

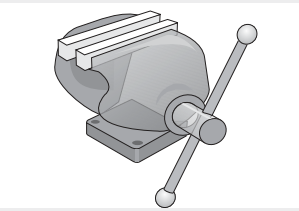

100% Pre-assembly in vice with VOMO

- Reliable method for repair jobs
- Only economic for assembly of small quantities
- For tubes over 25mm, EO-KARRYMAT is recommended



- 1**
- Cones of pre-assembly bodies VOMO must be checked regularly (after 50 pre-assemblies) with cone gauges (KONU)
 - ⚠ The rear of the gauge must protrude slightly above the top face of the cone or may be flush
 - Check insertion depth according to VOMO checking instructions
 - Clean and lubricate assembly cone and thread regularly



- 2**
- Use pre-assembly tool VOMO
 - Fitting body may be used one time only and components must stay together
 - Screw on nut until finger-tight



- 3**
- ⚠ Press tube-end firmly into the assembly cone

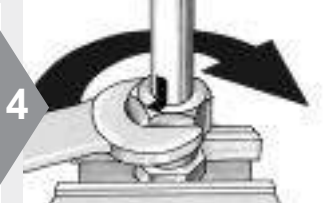

- 4**
- ⚠ Mark position of the nut
 - Tighten the nut by 1 1/2 turns
 - ⚠ Recommended to use spanner extension for sizes over 20mm O.D. (**see chart**)



- 5**
- Assembly check:**
- Loosen nut
 - ⚠ Check to make sure that a visible collar covers the front of the first cutting edge
 - ⚠ It does not matter if the ring can be rotated on the tube-end



- 6**
- Assemble fitting until wrench-tight (without spanner extension)
 - ⚠ Mark position of nut

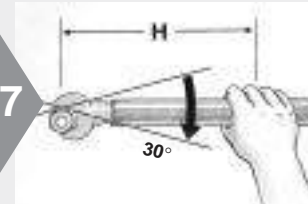

- 7**
- ⚠ Then tighten fitting firmly by 30° (1/2 flat)
 - ⚠ Recommended to use spanner extension for sizes over 20 mm O.D. (**see chart**)
 - Assembly torques are available on request

Spanner length

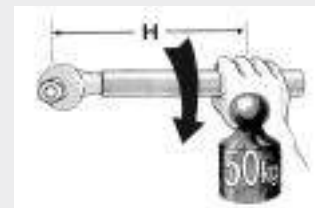

Size	Spanner length H [mm]
22-L	400
28-L 20-S	500
35-L 25-S	800
42-L 30-S	1000
38-S	1200

EO Progressive Stop Ring PSR assembly instructions

Only for New Generation PSR fittings

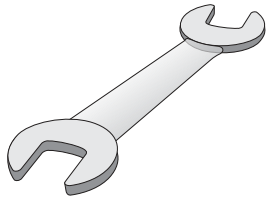

Direct assembly

- Simple procedure for single assemblies of small dimensions
- Not economic for series assembly
- ⚠ Tubes \varnothing 30, 35, 38 and 42 mm must be pre-assembled in vice



1

- ⚠ Lubrication of threads will reduce wear and assembly forces



2

- Screw on nut until finger-tight
- Press tube-end firmly into fitting body

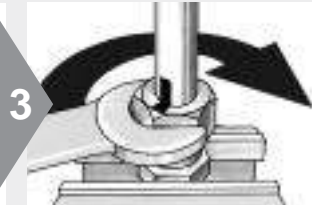
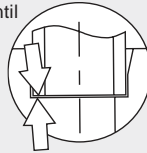

3

- Mark position of the nut
- Tighten the nut by $1\frac{1}{2}$ turns
- ⚠ Recommended to use spanner extension for sizes over 20 mm O.D. (see chart)



4

- Assembly check:**
- Loosen nut
 - ⚠ Check to make sure that a visible collar covers the front of the first cutting edge
 - It does not matter if the ring can be rotated on the tube-end

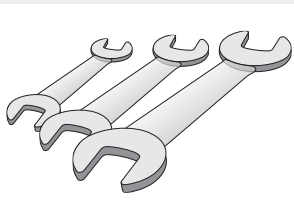

Repeated assembly

- Each time the tube-end has been disconnected, the fitting must be properly tightened again
- ⚠ EO Progressive Stop Rings PSR cannot be replaced, once assembled



1

- First assemble fitting until wrench tight (without spanner extension)

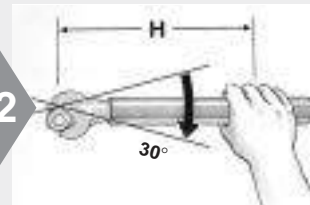

2

- Then tighten fitting firmly by 30° ($\frac{1}{2}$ flat)
- Assembly torques are available on request
- ⚠ Recommended to use spanner extension for sizes over 20 mm O.D. (see chart)

Spanner length

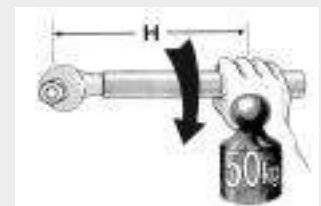

Size	Spanner length H [mm]
22-L	400
28-L 20-S	500
35-L 25-S	800
42-L 30-S	1000
38-S	1200

EO Progressive Ring DPR assembly instructions

Also applicable for New Generation PSR fittings

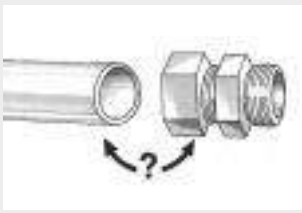

Material combinations

- Select suitable EO progressive ring fitting

Tube material	EO-Fitting body	assembly instructions
Steel	Steel	
Stainless Steel	Stainless Steel	Pre-assembly by machine or hardened tool required
Copper	Brass	
Plastic e.g. Polyamide	Steel or Brass	Support sleeve E required
Stainless Steel	Steel	Stainless Steel PSR/DPR must be used Pre-assembly by machine or hardened tool required



Tube preparation

- Cut and deburr thoroughly
- Do not assemble under tension
- Clamp onto rigid fixtures



1

- Cut tube squarely
- max $\pm 1^\circ$ deviation
- ⚠ Do not use pipe cutters
- EO tube-cutting tool (AV) for manual cutting



2

- Min. length of straight tube ends
H = 2x nut size
- Use swivel union "GZ" instead of short tubes



3

- Remove internal and external burrs
- max. chamfer 0.3mm x 45°
- Recommendation: In-Ex Tube Deburring Tool 226



Support sleeves VH

- Support sleeve VH for thin wall or soft metal tubes
- See chart for VH selection



Tube insert E

- Support sleeve E for plastic tubes



1

- Insert support sleeve like shown



2

- Drive VH into tube-end

- Support sleeve required
- Support sleeve required for heavily loaded lines (vibrations)

VH selection chart for EO Progressive Ring
For steel tubes material ST 37.4
and for stainless steel tubes material 1.4571 and 1.4541

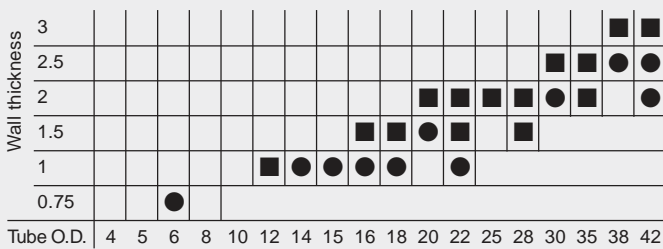

For soft metal tubes (e. g. copper)

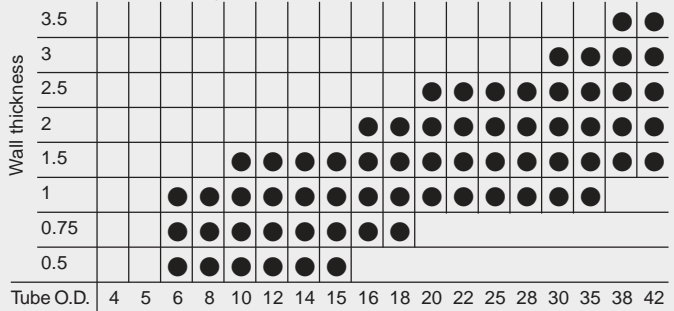

EO Progressive Ring DPR assembly instructions

Also applicable for New Generation PSR fittings

Pre-assembly with Eomat/EO-Karrymat

- Preferred and
- Most efficient method
- HVM-B device not recommended



EOMAT II



EOMAT III/A



EO-KARRYMAT

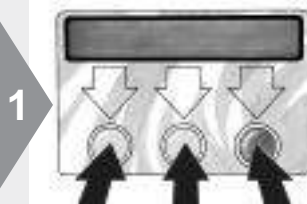

1

- EOMAT II: Adjustment according to pressure chart on machine (DPR)
- EOMAT III/A: Menu selection (DPR)
- EO-KARRYMAT: Refer to chart on machine (DPR)
- Non-EOMAT-machines: Check suitability



2

- The assembly cones (MOK) must be checked regularly (after 50 pre-assemblies) with cone gauges (KONU)
- The rear of the gauge must protrude slightly above the top face of the cone or may be flush
- Check insertion depth according to MOK checking instructions



3

- Insert proper tools
- Clean and lubricate assembly cones regularly
- EO-KARRYMAT: Close valve on handpump
- 2-piece backing plates for 35-L and 42-L



4

- Slide nut and progressive ring as shown onto the end of the tube

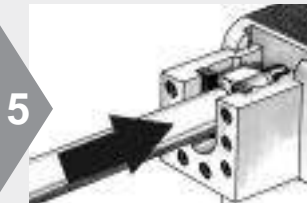

5

- Place tube with progressive ring and nut into the die
- Press tube-end firmly into the assembly cone



6

- Hold tube firmly
- EOMAT: Press and hold start button
- Use support and foot switch for long tubes
- EO-KARRYMAT: Operate handpump until assembly pressure is reached



7

- After completion of pre-assembly, remove the tube for assembly check
- EO-KARRYMAT: Open valve on handpump



8

- ⚠ Check to make sure that a visible collar covers the front of the first cutting edge
- It does not matter if the ring can be rotated on the tube end



9

- ⚠ Threads of stainless steel fittings must be lubricated
- Use EO-NIROMONT special high-performance lubricant for stainless steel fittings

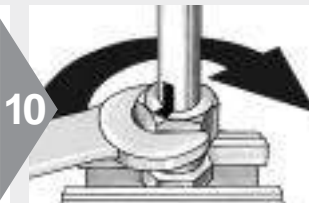

10

- Assemble fitting until wrench-tight
- ⚠ Mark position of nut

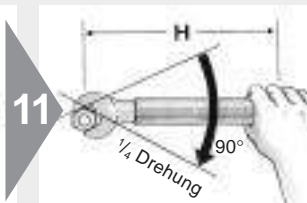

11

- ⚠ Then tighten fitting firmly by 1/4 turn (1 1/2 flats)
- ⚠ Recommended to use spanner extension for sizes over 20 mm O.D. (see chart)
- ⚠ Threads on stainless steel must be lubricated

Spanner length

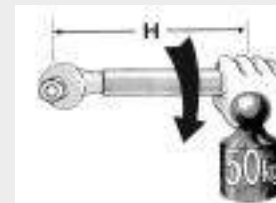

Size	Spanner length H [mm]
18-L 16-S	300
22-L	400
28-L 20-S	500
35-L 25-S	900
42-L 30-S	1200
38-S	1500



EO Progressive Ring DPR assembly instructions

Also applicable for New Generation PSR fittings

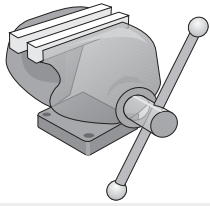

Pre-assembly in vice with VOMO

- Reliable method for repair jobs
- Only economic for assembly of small quantities
- ⚠ Stainless steel EO progressive rings must be preassembled using a hardened tool (VOMO)
- For tubes over 25mm, EO-KARRYMAT / EOMAT is recommended



- 1
- ⚠ For stainless steel assembly threads must be lubricated
 - Use EO-NIROMONT special high-performance lubricant for stainless steel fittings



- 2
- Cones of pre-assembly bodies must be checked regularly (after 50 pre-assemblies) with cone gauges (KONU)
 - ⚠ The rear of the gauge must protrude slightly above the top face of the cone or may be flush
 - Check insertion depth according to VOMO checking instructions (see chart)
 - Clean and lubricate assembly cone and thread regularly



- 3
- Use pre-assembly tool VOMO
 - Fitting body may be used one time only (not for stainless steel)
 - Screw on nut until finger-tight



- 4
- ⚠ Press tube-end firmly into the assembly cone

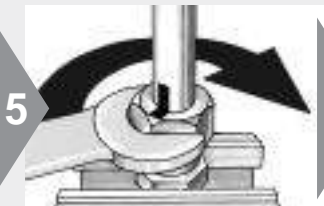
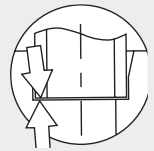

- 5
- ⚠ Mark position of the nut
 - Tighten the nut by 1 1/4 turns
 - ⚠ Recommended to use spanner extension for sizes over 20 mm O.D.



- 6
- Assembly check:**
- Loosen nut
 - ⚠ Check to make sure that a visible collar covers the front of the first cutting edge
 - ⚠ It does not matter if the ring can be rotated on the tube-end



- 7
- Assemble fitting until wrench-tight (without spanner extension)
 - ⚠ Mark position of nut

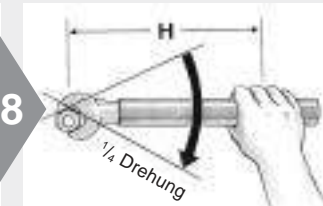

- 8
- ⚠ Then tighten fitting firmly by 1/4 turn (1 1/2 flats)
 - ⚠ Recommended to use spanner extension for sizes over 20 mm O.D. (see chart)

Spanner length

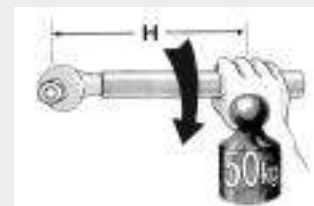

Size	Spanner length H [mm]
18-L 16-S	300
22-L	400
28-L 20-S	500
35-L 25-S	900
42-L 30-S	1200
38-S	1500

EO Progressive Ring DPR assembly instructions

Also applicable for New Generation PSR fittings

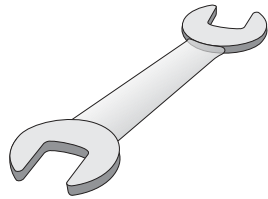

Direct assembly

- Simple procedure for single assemblies of small dimensions
- Not economic for series assembly
- ⚠ Tubes Ø 30, 35, 38 and 42 mm must be pre-assembled in vice
- ⚠ Stainless steel connections have to be assembled using pre-assembly tool (VOMO)



- 1
- ⚠ Lubrication of threads will reduce wear and assembly forces
 - ⚠ Threads on stainless steel fittings must be lubricated
 - ⚠ Use EO-NIROMONT special high-performance lubricant for stainless steel fittings



- 2
- Screw on nut until finger-tight
 - ⚠ Press tube-end firmly into fitting body

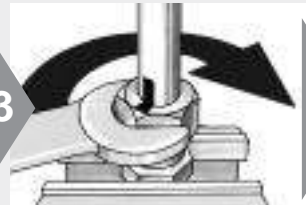
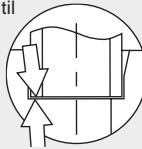

- 3
- Mark position of the nut
 - Tighten the nut by 1½ turns
 - ⚠ Recommended to use spanner extension for sizes over 20 mm O.D. (see chart)
 - Fitting body may be used one time only



- 4
- Assembly check:**
- Loosen nut
 - ⚠ Check to make sure that a visible collar covers the front of the first cutting edge
 - It does not matter if the ring can be rotated on the tube-end

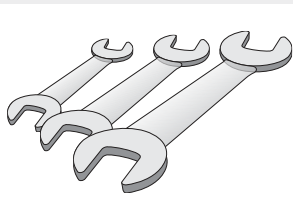

Repeated assembly

- Each time the tube-end has been disconnected, the fitting must be properly tightened again
- ⚠ EO progressive rings cannot be replaced, once assembled



- 1
- ⚠ Threads on stainless steel fittings must be lubricated
 - ⚠ Use EO-NIROMONT special high-performance lubricant for stainless steel fittings



- 2
- Each time the fitting has been loosened, re-assembly must be performed with the same torque as initial assembly
 - The body must be held rigid
 - ⚠ Recommended to use spanner extension for sizes over 20 mm O.D. (see chart)

Spanner length

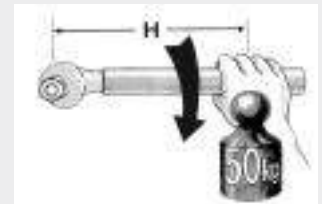

Size	Spanner length H [mm]
18-L 16-S	300
22-L	400
28-L 20-S	500
35-L 25-S	900
42-L 30-S	1200
38-S	1500

EO-2 assembly instructions

Detailed assembly-instructions are included in each EO-2 product box.
Details on Eomat setting and selection of support sleeves can be found there as well.



Tube preparation

- Cut and deburr thoroughly
- Do not assemble under tension
- Clamp onto rigid fixtures



Material combinations

- Select suitable FM-type



1

- Cut tube squarely
- max $\pm 1^\circ$ deviation
- ⚠ Do not use pipe cutters
- EO tube-cutting tool (AV)



2

- Remove internal and external burrs
- max. chamfer 0.3mm x 45°
- Seal can be damaged by large burrs

	Steel tube	Stainless Steel tube	Plastic tube
Steel fitting	FM...A3C	FM...SSA	FM...A3C+E
Stainless Steel fitting	—	FM...71	FM...71+E



Support sleeves VH

- Support sleeve VH for thin wall or soft metal tubes



Tube insert E

- Tube insert E for plastic tubes



1

- Support-sleeve selection: see instruction shipped with product box



2

- Drive VH into tube-end



Replacement of sealing ring/Repeated assembly

- Sealing ring DOZ can be changed separately



1

- After disassembly, sealing ring can be pulled off the tube-end
- Check for damage and replace if necessary
- Abrasion on outer rubber parts does not effect performance



2

- Assemble fitting until wrench-tight (without spanner extension)

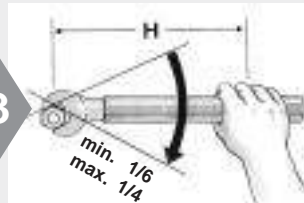

3

- ⚠ Then tighten fitting firmly by min $\frac{1}{6}$ (max $\frac{1}{4}$) turn (1 to $1\frac{1}{2}$ flats)
- ⚠ Recommended to use spanner extension for sizes over 20 mm O.D. (see chart)

Spanner length

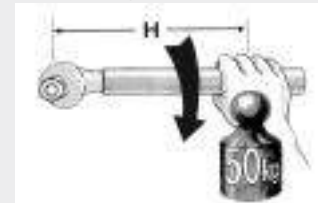

Size	Spanner length H [mm]
22-L	400
28-L 20-S	500
35-L 25-S	800
42-L 30-S	1000
38-S	1200

EO-2 assembly instructions

Assembly with Eomat/EO-Karrymat

- Preferred and Most efficient method
- HVM-B device is not suitable for EO-2



EOMAT II



EOMAT III/A



EO-KARRYMAT

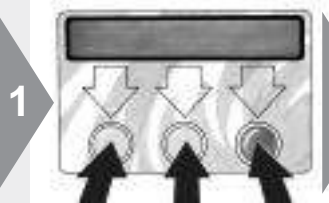

1

- EOMAT II: Adjustment according to pressure on machine (see instructions shipped with product box)
- EOMAT III/A: Menu selection
- EO-KARRYMAT: Refer to chart on machine
- Non-EOMAT-machines: check suitability



2

- Check insertion depth according to MOK checking instructions
- Use special EO-2 MOK (silver) for Tube-OD 25 mm and larger. Advantages: easy and safe assembly

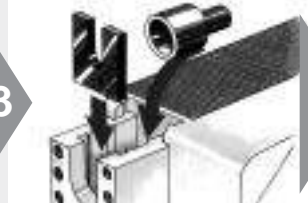

3

- Insert proper tools
- 2-piece tube backing plates for 35-L and 42-L
- EO-KARRYMAT: Close valve on handpump

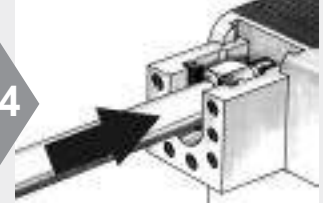
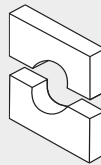

4

- Place tube with functional nut into the die
- Press tube-end firmly into the assembly cone
- Hold back nut for easy tube insertion

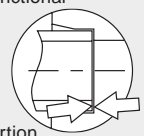

5

- Hold tube firmly
- EOMAT: Press and hold start button
- Use support and foot switch for long tubes
- EO-KARRYMAT: Operate handpump until assembly pressure is reached. Then open valve on handpump



6

- Assembly check:**
- Gap between sealing ring and retaining ring must be closed
 - A little relaxation (approx. 0.2 mm) is allowed

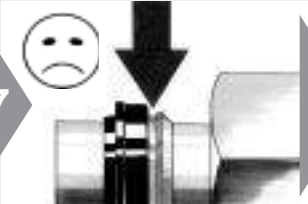

7

- ⚠ Gap not closed:**
- Check all components, tube, machine, tools and pressure setting
 - Repeat assembly with increased pressure if necessary



8

- ⚠ Threads of stainless steel fittings must be lubricated
- ⚠ Use EO-NIROMONT special high-performance lubricant for stainless steel fittings



9

- Assemble fitting until wrench-tight (without spanner extension)

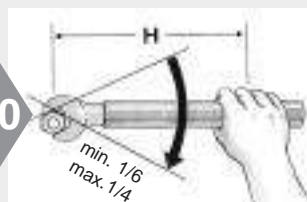

10

- ⚠ Then tighten fitting firmly by min 1/6 (max. 1/4) turn (1 to 1 1/2 flats)
- ⚠ Recommended to use spanner extension for sizes over 20 mm O.D. (see chart)

Spanner length

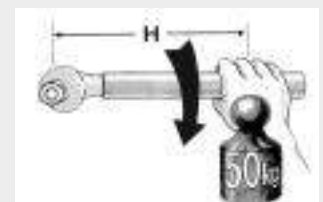

Size	Spanner length H [mm]
22-L	400
28-L 20-S	500
35-L 25-S	800
42-L 30-S	1000
38-S	1200

EO-2 assembly instructions

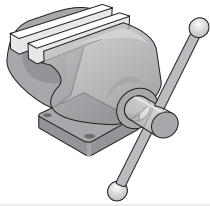

Assembly in vice

- Reliable method
- Only economic for assembly of small quantities

1



- ⚠ Threads on stainless steel fittings must be lubricated
- ⚠ Use EO-NIROMONT special high-performance lubricant for stainless steel fittings

2



Ok?

- Check insertion depth according to VOMO checking instructions
- Use pre-assembly tool VOMO
- Fitting body may be used one time only and components must stay together

3



- Push functional nut onto tube-end
- Advantage: Easy tube insertion, particularly large dimensions

4



- ⚠ Press tube-end firmly into the assembly cone
- Screw on nut until finger-tight

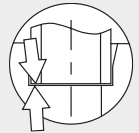

5

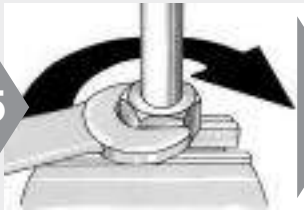

- Tighten until sharp increase of resistance (approx. 1 to 1 1/2 turns)
- ⚠ Recommended to use spanner extension for sizes over 20 mm O.D. (see chart)

6



- Assembly check:**
- Gap between sealing ring and retaining ring must be closed
 - A little relaxation (approx. 0.2 mm) is allowed

7

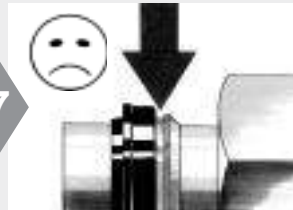

- ⚠ **Gap not closed:** Check all components including tube

8



- Assemble fitting until wrench-tight (without spanner extension)

9

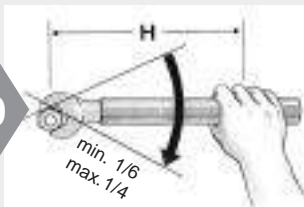

- ⚠ Then tighten fitting firmly by min 1/6 (max. 1/4) turn (1 to 1 1/2 flats)
- ⚠ Recommended to use spanner extension for sizes over 20 mm O.D. (see chart)

Spanner length

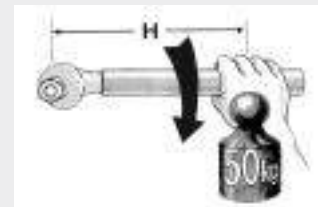

Size	Spanner length H [mm]
22-L	400
28-L 20-S	500
35-L 25-S	800
42-L 30-S	1000
38-S	1200

EO-2 assembly instructions

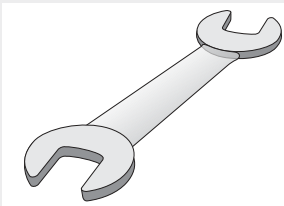

Direct assembly

- Simple procedure for single assemblies of small dimensions
- Not economic for series assemblies
- ⚠ Tubes Ø 30, 35, 38 and 42 mm must be pre-assembled in vice

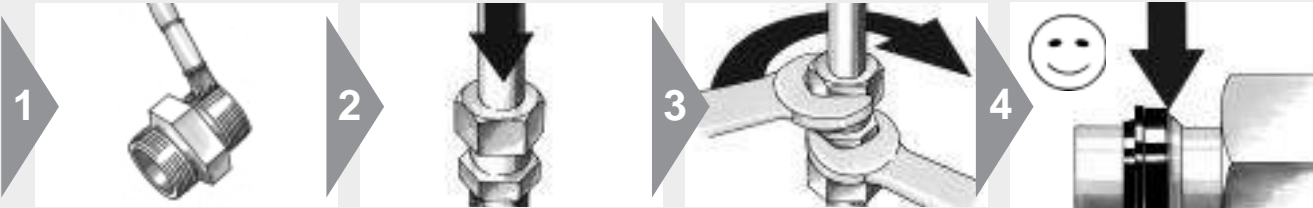

- 1
- ⚠ Threads on stainless steel fittings must be lubricated
 - ⚠ EO-NIROMONT is a special high-performance lubricant for stainless steel fittings

- 2
- ⚠ Press tube-end firmly into the assembly cone
 - Turn back nut for easy tube insertion

- 3
- Tighten until sharp increase of resistance (approx. 1 to 1 1/2 turns)
 - ⚠ Recommended to use spanner extension for sizes over 20 mm O.D. (see chart)

- 4
- Assembly check:**
- Gap between sealing ring and retaining ring must be closed
 - A little relaxation (approx. 0.2 mm) is allowed



- 5
- ⚠ **Gap not closed:** Check all components including tube



- 6
- Assemble fitting until wrench-tight (without spanner extension)

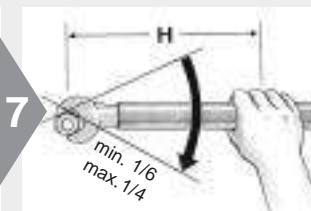

- 7
- ⚠ Then tighten fitting firmly by min 1/6 (max 1/4) turn (1 to 1 1/2 flats)
 - ⚠ Recommended to use spanner extension for sizes over 20 mm O.D. (see chart)

Spanner length

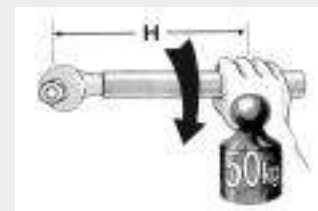

Size	Spanner length H [mm]
22-L	400
28-L 20-S	500
35-L 25-S	800
42-L 30-S	1000
38-S	1200

Checking instructions for EO assembly tools

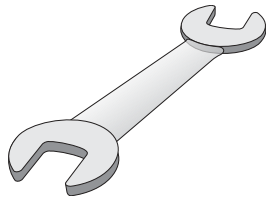

VOMO tools for manual pre-assembly in vice MOK for use in EO assembly machines

- ⚠ Use of damaged, worn or non-suitable tooling may result in fitting failure or machine damage
- ⚠ Tools must be checked regularly, at least after 50 assemblies
- ⚠ Worn tools must be replaced ⚠ Use only genuine Parker tools
- ⚠ Tools must be kept clean and lubricated

1



- Clean cone surface for checking
- Visual checks:
Cone must be free of wear, damage or cracks

2



- Check for deformation of geometry
- ⚠ Special cone gauge KONU must be used
- KONU cone gauges are precision measuring devices and must be handled accordingly

3

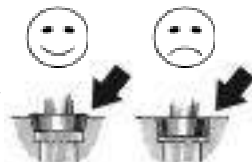

- Check contour:
The rear of the gauge must protrude slightly above the top face of the cone or may be flush

4

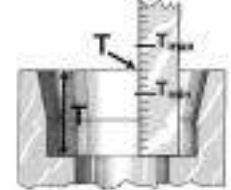

- Check insertion depth

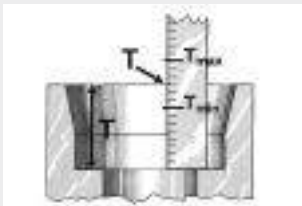

- Insertion depth T

Table: Tool for presetting tool (Mok and Vomo)

Type	T _{min}	T _{max}	Type	T _{min}	T _{max}
6-L	6.95	7.05	6-S	6.95	7.05
8-L	6.95	7.05	8-S	6.95	7.05
10-L	6.95	7.05	10-S	7.45	7.55
12-L	6.95	7.05	12-S	7.45	7.55
15-L	6.95	7.05	14-S	7.95	8.05
18-L	7.45	7.55	16-S	8.45	8.55
22-L	7.45	7.55	20-S	10.45	10.55
28-L	7.45	7.55	25-S	11.95	12.05
35-L	10.45	10.55	30-S	13.45	13.55
42-L	10.95	11.05	38-S	15.95	16.05

EO2-FORM assembly instructions



Material combinations

- Select suitable materials
- See catalogue for exact tube specifications

Material selection chart

Tube material	Fitting and nut material	Sealing material
Steel	Steel	Steel/NBR or Steel/FKM
Stainless Steel	Stainless Steel	Stainless Steel/FKM/NBR
Stainless Steel	Steel	Steel/NBR or Steel/FKM



Tube preparation

- Cut and deburr thoroughly
- Cut and bend tubes exactly

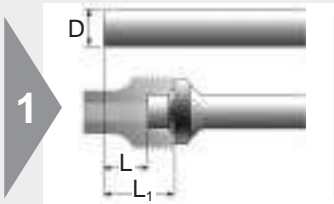

1

- Take extra length into account (see tube preparation chart)

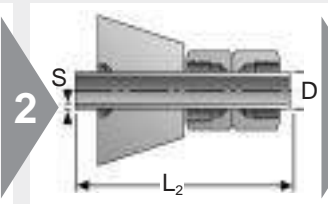

2

- Minimum lengths L_2 of straight tubes (see chart)

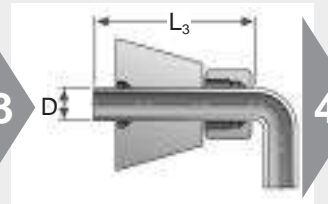

3

- Minimum lengths L_3 of straight tube-ends before bend (see chart)



4

- Cut tube squarely
- max $\pm 1^\circ$ deviation
- ⚠ Do not use pipe cutters
- EO tube-cutting tool (AV) for manual cutting



5

- Remove internal and external burrs
- max. chamfer 0.3mm x 45°
- Clean tube thoroughly

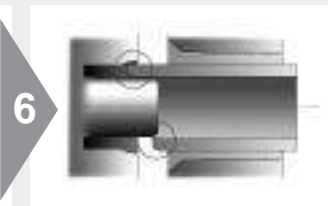

6

- Chips, dirt, internal or external burrs and paint prevent correct tube insertion
- ⚠ Dirty tubes result in worn-out or damaged tools



EO2-FORM assembly instructions

Tube preparation chart - Series L

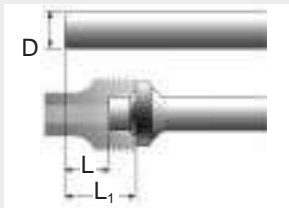

● Extra length

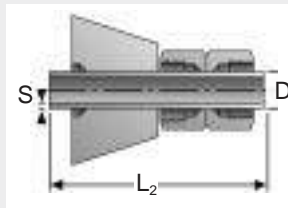

● Minimum tube length

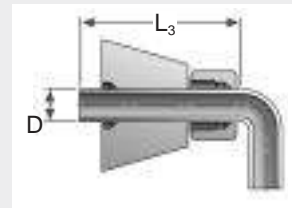

● Minimum straight length before bend

Tube-OD Series	S Wall thickness	L Steel	L Stainless Steel	L ₁ Steel	L ₁ Stainless Steel	L ₂	L ₃																																																																																																																																																																	
6L	1	8.5	8.5	15.5	15.5	90	63																																																																																																																																																																	
	1.5	6	6	13	13			8L	1	8.5	9	15.5	16	92	65	1.5	5.5	6	12.5	13	10L	1	5.5	5.5	12.5	12.5	95	68	1.5	5	6.5	12	13.5	12L	1	5	6	12	13	95	70	1.5	5	6	12	13	15L	1.5	5.5	7	12.5	14	102	75	2	5.5	7	12.5	14	18L	2.5	5.5	7	12.5	14	110	80	1.5	5.5	7	13	14.5	22L	2	5.5	7	13	14.5	120	90	3	5.5		13		28L	1.5	6	8	13.5	15.5	140	98	2	6	8	13.5	15.5	35L	2.5					170	115	3					42L	1.5	6.5	7.5	14	15	190	125	2	7	8.5	17.5	19	42L	3	8.5	10.5	19	21	190	125	3.3					42L	4					190	125	5					42L	2	7.5	9	18.5	20	190	125	3	9	11.5	20	22.5	42L	4	9		20
8L	1	8.5	9	15.5	16	92	65																																																																																																																																																																	
	1.5	5.5	6	12.5	13			10L	1	5.5	5.5	12.5	12.5	95	68	1.5	5	6.5	12	13.5	12L	1	5	6	12	13	95	70	1.5	5	6	12	13	15L	1.5	5.5	7	12.5	14	102	75	2	5.5	7	12.5	14	18L	2.5	5.5	7	12.5	14	110	80	1.5	5.5	7	13	14.5	22L	2	5.5	7	13	14.5	120	90	3	5.5		13		28L	1.5	6	8	13.5	15.5	140	98	2	6	8	13.5	15.5	35L	2.5					170	115	3					42L	1.5	6.5	7.5	14	15	190	125	2	7	8.5	17.5	19	42L	3	8.5	10.5	19	21	190	125	3.3					42L	4					190	125	5					42L	2	7.5	9	18.5	20	190	125	3	9	11.5	20	22.5	42L	4	9		20		190	125										
10L	1	5.5	5.5	12.5	12.5	95	68																																																																																																																																																																	
	1.5	5	6.5	12	13.5			12L	1	5	6	12	13	95	70	1.5	5	6	12	13	15L	1.5	5.5	7	12.5	14	102	75	2	5.5	7	12.5	14	18L	2.5	5.5	7	12.5	14	110	80	1.5	5.5	7	13	14.5	22L	2	5.5	7	13	14.5	120	90	3	5.5		13		28L	1.5	6	8	13.5	15.5	140	98	2	6	8	13.5	15.5	35L	2.5					170	115	3					42L	1.5	6.5	7.5	14	15	190	125	2	7	8.5	17.5	19	42L	3	8.5	10.5	19	21	190	125	3.3					42L	4					190	125	5					42L	2	7.5	9	18.5	20	190	125	3	9	11.5	20	22.5	42L	4	9		20		190	125																							
12L	1	5	6	12	13	95	70																																																																																																																																																																	
	1.5	5	6	12	13			15L	1.5	5.5	7	12.5	14	102	75	2	5.5	7	12.5	14	18L	2.5	5.5	7	12.5	14	110	80	1.5	5.5	7	13	14.5	22L	2	5.5	7	13	14.5	120	90	3	5.5		13		28L	1.5	6	8	13.5	15.5	140	98	2	6	8	13.5	15.5	35L	2.5					170	115	3					42L	1.5	6.5	7.5	14	15	190	125	2	7	8.5	17.5	19	42L	3	8.5	10.5	19	21	190	125	3.3					42L	4					190	125	5					42L	2	7.5	9	18.5	20	190	125	3	9	11.5	20	22.5	42L	4	9		20		190	125																																				
15L	1.5	5.5	7	12.5	14	102	75																																																																																																																																																																	
	2	5.5	7	12.5	14			18L	2.5	5.5	7	12.5	14	110	80	1.5	5.5	7	13	14.5	22L	2	5.5	7	13	14.5	120	90	3	5.5		13		28L	1.5	6	8	13.5	15.5	140	98	2	6	8	13.5	15.5	35L	2.5					170	115	3					42L	1.5	6.5	7.5	14	15	190	125	2	7	8.5	17.5	19	42L	3	8.5	10.5	19	21	190	125	3.3					42L	4					190	125	5					42L	2	7.5	9	18.5	20	190	125	3	9	11.5	20	22.5	42L	4	9		20		190	125																																																	
18L	2.5	5.5	7	12.5	14	110	80																																																																																																																																																																	
	1.5	5.5	7	13	14.5			22L	2	5.5	7	13	14.5	120	90	3	5.5		13		28L	1.5	6	8	13.5	15.5	140	98	2	6	8	13.5	15.5	35L	2.5					170	115	3					42L	1.5	6.5	7.5	14	15	190	125	2	7	8.5	17.5	19	42L	3	8.5	10.5	19	21	190	125	3.3					42L	4					190	125	5					42L	2	7.5	9	18.5	20	190	125	3	9	11.5	20	22.5	42L	4	9		20		190	125																																																														
22L	2	5.5	7	13	14.5	120	90																																																																																																																																																																	
	3	5.5		13				28L	1.5	6	8	13.5	15.5	140	98	2	6	8	13.5	15.5	35L	2.5					170	115	3					42L	1.5	6.5	7.5	14	15	190	125	2	7	8.5	17.5	19	42L	3	8.5	10.5	19	21	190	125	3.3					42L	4					190	125	5					42L	2	7.5	9	18.5	20	190	125	3	9	11.5	20	22.5	42L	4	9		20		190	125																																																																											
28L	1.5	6	8	13.5	15.5	140	98																																																																																																																																																																	
	2	6	8	13.5	15.5			35L	2.5					170	115	3					42L	1.5	6.5	7.5	14	15	190	125	2	7	8.5	17.5	19	42L	3	8.5	10.5	19	21	190	125	3.3					42L	4					190	125	5					42L	2	7.5	9	18.5	20	190	125	3	9	11.5	20	22.5	42L	4	9		20		190	125																																																																																								
35L	2.5					170	115																																																																																																																																																																	
	3							42L	1.5	6.5	7.5	14	15	190	125	2	7	8.5	17.5	19	42L	3	8.5	10.5	19	21	190	125	3.3					42L	4					190	125	5					42L	2	7.5	9	18.5	20	190	125	3	9	11.5	20	22.5	42L	4	9		20		190	125																																																																																																					
42L	1.5	6.5	7.5	14	15	190	125																																																																																																																																																																	
	2	7	8.5	17.5	19			42L	3	8.5	10.5	19	21	190	125	3.3					42L	4					190	125	5					42L	2	7.5	9	18.5	20	190	125	3	9	11.5	20	22.5	42L	4	9		20		190	125																																																																																																																		
42L	3	8.5	10.5	19	21	190	125																																																																																																																																																																	
	3.3							42L	4					190	125	5					42L	2	7.5	9	18.5	20	190	125	3	9	11.5	20	22.5	42L	4	9		20		190	125																																																																																																																															
42L	4					190	125																																																																																																																																																																	
	5							42L	2	7.5	9	18.5	20	190	125	3	9	11.5	20	22.5	42L	4	9		20		190	125																																																																																																																																												
42L	2	7.5	9	18.5	20	190	125																																																																																																																																																																	
	3	9	11.5	20	22.5			42L	4	9		20		190	125																																																																																																																																																									
42L	4	9		20		190	125																																																																																																																																																																	

EO2-FORM assembly instructions

Tube preparation chart - Series S

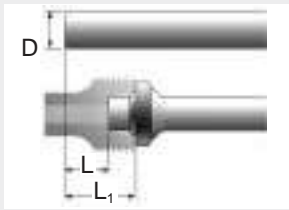

● Extra length

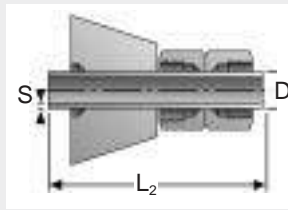

● Minimum tube length

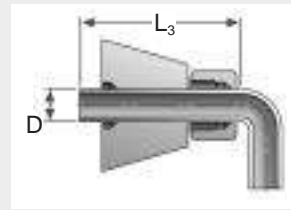

● Minimum straight length before bend

Tube-OD Series	S Wall thickness	L Steel	L Stainless Steel	L ₁ Steel	L ₁ Stainless Steel	L ₂	L ₃
6S	1	8.5	8.5	15.5	15.5	92	65
	1.5	6	6	13	13		
	2	5.5		12.5			
8S	1	8.5	9	15.5	16	95	68
	1.5	5.5	6	12.5	13		
	2	5		12			
10S	1.5	5	6.5	12.5	14	100	70
	2	5.5	6.5	13	14		
12S	1.5	5	6.5	12.5	14	100	72
	2	5	6.5	12.5	14		
16S	1.5	5.5	7	14	15.5	110	80
	2	5.5	7	14	15.5		
	2.5	5.5	7	14	15.5		
	3	5.5	7	14	15.5		
20S	2	7	8.5	17.5	19	135	98
	2.5	7	8.5	17.5	19		
	3	7	8.5	17.5	19		
	3.5	7		17.5			
25S	2	8.5	10.5	20.5	22.5	155	112
	2.5	8.5	10.5	20.5	22.5		
	3	8.5	10.5	20.5	22.5		
	4	8.5		20.5			
30S	3	8.5	10.5	22	24	165	122
	4	9.5	11	23	24.5		
	5	8.5		22			
	2.5		11		27		
38S	3	11	11	27	27	190	135
	3.5	11		27			
	4	11	12	27	28		
	5	11	13	27	29		
	6	11.5		27.5			
	7	11.5		27.5			



EO2-FORM assembly instructions



Tube forming with EO2-FORM F2

- Reliable forming method

<p>1</p>	<p>2</p>	<p>3</p>	<p>4</p>
<ul style="list-style-type: none"> ⚠ Change tool only when drive switched off (button O) ⚠ Obey safety instructions 	<ul style="list-style-type: none"> ● Select suitable forming die according to tube material, outer diameter and wall thickness 	<ul style="list-style-type: none"> ● Select suitable clamping dies according to tube outer diameter ⚠ Keep stainless tube clamping dies separate from other tube materials to prevent contact corrosion 	<ul style="list-style-type: none"> ● Check clamping dies for dirt, wear and damage
<p>5</p>	<p>6</p>	<p>7</p>	<p>8</p>
<ul style="list-style-type: none"> ● Check forming die for dirt, wear and damage 	<ul style="list-style-type: none"> ● Use magnetic holder to insert forming die ● Turn clockwise to lock bayonet fixture 	<ul style="list-style-type: none"> ● Insert clamping dies in holder ● Pins must lock in drill holes ● Use handling pin for easy die insertion 	<ul style="list-style-type: none"> ● Switch on drive (button I) ● Each time the drive is switched on, the reset button (R) must be pressed first ● The automatic tool recognition is initiated ⚠ Clamping dies will close Reset button (R) must be held until it lights up ● Lighten of reset button (R) indicates "ready to start"
<p>9</p>	<p>10</p>	<p>11</p>	<p>12</p>
<ul style="list-style-type: none"> ⚠ Make sure tube-end is free of burrs, chips and dirt ⚠ Lubricate inside and outside of tube-end ● Use EO-NIROMONT for best performance 	<ul style="list-style-type: none"> ● Insert tube-end with nut into open tool until it firmly touches the stop at the end ⚠ Press tube-end firmly into the tube stop ● Do not turn tube-end anti-clockwise 	<ul style="list-style-type: none"> ● Press and hold start button until tube is clamped ● Instead of start-button foot-switch can be used ⚠ Hold tube firmly until clamping dies are closed ● Use support for long tubes ⚠ Do not reach into tool area while machine is working 	<ul style="list-style-type: none"> ● Tube can be taken out after the clamping dies are open ● Reset button (R) lights up and the machine is ready for the next operation ● Check tools regularly (approx. 50 assemblies) for dirt and wear ● Remove tools for cleaning ● Clean clamping dies with wire brush ● Clean forming die using compressed air ● Replace worn-out tooling

EO2-FORM assembly instructions



Assembly check

- Check assembly result
- ⚠ Incorrect assemblies must be scrapped

Tube OD check

Tube Ø-Series	min Ø [mm]	max Ø [mm]
6-L/S	9	10.2
8-L/S	11	12.2
10-L	13.2	14.2
12-L	15.2	16.2
15-L	18.5	20.2
18-L	21.5	24
22-L	26	27.7
28-L	32	33.7
35-L	39.5	42.5
42-L	46.5	49.5
10-S	13.5	15.5
12-S	15.5	17.5
16-S	19.5	21.5
20-S	24.5	27.5
25-S	30	34
30-S	35	39
38-S	43	47

1

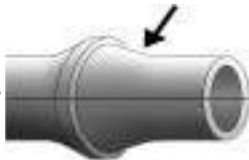

- Sealing surface (arrow) must be free of scratches and damage

2

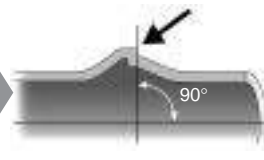

- Check contour: Contact surface for sealing ring (arrow) must be flat, at right angle to tube

3



- Check outer diameter Ø... (see chart)
- ⚠ Incorrect tube-ends must be scrapped. Tools must be cleaned and checked

Installation

- ⚠ Tube must fit without tension



1



- Place sealing ring (DOZ) onto tube-end

2



- Threads of stainless steel fittings must be lubricated
- EO-NIROMONT is a special high-performance lubricant for stainless steel fittings

3



- Tube must fit without tension
- Assemble fitting until wrench-tight (without spanner extension)

4

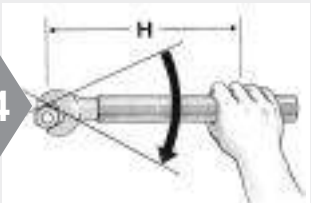

- ⚠ Then tighten fitting firmly by 1/6 turn (1 flat)
- ⚠ Recommended to use spanner extension for sizes over 20 mm O.D. (see chart)
- ⚠ Incorrect assembly reduces performance and reliability of the connection

Spanner length

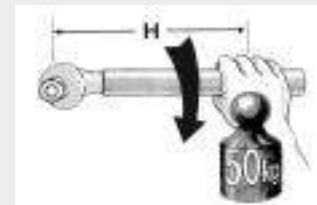

Size	Spanner length H [mm]
22-L	400
28-L 20-S	500
35-L 25-S	800
42-L 30-S	1000
38-S	1200

Checking instructions for EO2-FORM tools



Forming pin and clamping dies for EO2-FORM machine

- ⚠ Use of damaged, worn or non-suitable tooling may result in fitting failure and damage of machine
- ⚠ Tools must be checked regularly, at least after 50 assemblies
- ⚠ Worn tools must be replaced
- ⚠ Use only genuine Parker tools
- ⚠ Tools must always be kept clean and lubricated

1



- Clean forming pin for checking
- Do not disassemble

2



- Visual check:
Surface must be free of wear and damage
- Use air blowgun to remove chips and dirt

3



- Clean clamping pin for checking
- Do not disassemble
- Pins must not be loose or damaged

4



- Visual check:
Grip surface must be clean and free of wear
- Use wire-brush to remove metal particles from grip surface

Weld fitting



Weld fitting assembly

- EO weld nipple and weld fitting
- ⚠ Use weldable material
- ⚠ Depending on application or project specification, special requirements may apply for: Tube preparation, welding process, operator qualification, inspection of welding connection and surface finish



Tube preparation

- Cut and deburr thoroughly
- Do not assemble under tension
- Clamp onto rigid fixtures

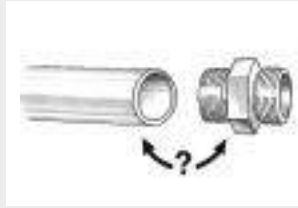

Material combinations

- Select suitable tube material

Fitting material	Tube specification
Steel	Weldable Steel
Stainless Steel	Weldable Stainless Steel

1



- Cut tube squarely
- max $\pm 1^\circ$ deviation
- ⚠ Do not use pipe cutters
- EO tube-cutting tool (AV) for manual cutting

2

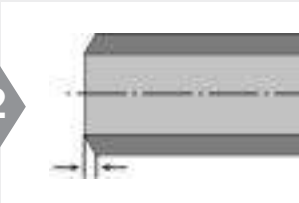

- Bevel tube-end similar to weld nipple bevel

Assembly

3



- Slide nut onto tube-end
- Weld fitting onto tube-end
- Fitting and tube must be aligned
- ⚠ Remove all elastomeric seals before welding

4



- Clean welding
- Calibrate inner diameter
- Check welding quality
- Surface protection if necessary

5

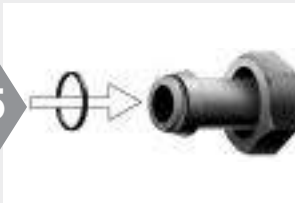

- Assemble O-ring
- Lubricate O-ring for easy assembly
- Avoid damage or twisting of O-ring

6



- ⚠ Threads of stainless steel fittings must be lubricated
- ⚠ Use EO-NIROMONT special high-performance lubricant for stainless steel fittings

7



- Screw on nut by hand until handtight

8

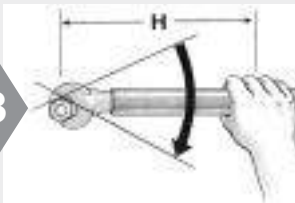

- ⚠ Then tighten fitting firmly by $\frac{1}{4}$ turn ($1\frac{1}{2}$ flats)



O-Lok® assembly instructions



Tube selection

- Select suitable tube material

Steel tube		Stainless Steel tube	
Cold drawn seamless	Welded & redrawn	Cold drawn seamless	
NF A 49330	NF A 49341	NF A 49341	
ISO 3304 R	DIN2393	DIN 17458 DA/T3	
DIN 2391C pt 1	BS 3602/2	ASTM A 269	
BS 3602 pt1	SAE J525	1.4571 on request	
SAE J524			



Tube preparation

- Cut and deburr thoroughly

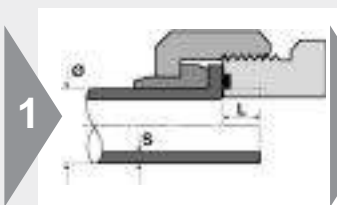

1

- Calculate tube length before cutting
- Add extra length "L"



2

- Minimum length of straight tube-ends (see chart below)



3

- Cut tube squarely
- max. $\pm 1^\circ$ deviation
- ⚠ Do not use pipe cutters
- Use tube-cutting tool AV for manual cutting



4

- Remove internal and external burrs
- max. chamfer 0.3mm x 45°
- Recommendation: In-Ex Tube Deburring Tool 226
- ⚠ Proper deburring and cleaning of inner diameter essential for sealing surface quality

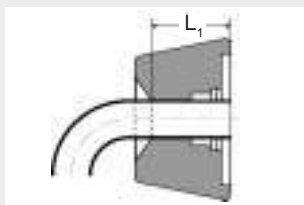

Metric tube [mm]		Minimum straight length to start to bend L1 [mm]	Extra length ~ L [mm] for Tube Wall thickness											
Tube Ø	Wall thickness		1	1.5	2	2.5	3	3.5	4	5				
6	1.0 - 1.5	40	4.5	5.5										
8	1.0 - 2.0	40	5.0	5.0										
10	1.0 - 2.0	40	2.5	4.0	3.5									
12	1.0 - 3.0	50	3.5	4.5	4.5	4.0	4.0							
14	1.5 - 2.0	50			5.0									
15	1.0 - 2.0	50		4.5	5.0									
16	1.5 - 3.0	50		3.0	3.0	3.0	2.5							
18	1.5 - 2.0	50		6.0	5.5									
20	2.0 - 3.5	50			3.5	4.0	4.0	3.5						
22	1.5 - 2.5	50			6.5	7.0								
25	2.0 - 4.0	50				4.0	4.5					4.0		
28	1.5 - 3.0	50			6.0	7.0								
30	2.0 - 4.0	50			5.0		5.0				5.0			
32	2.0 - 4.0	50					3.5				3.5			
35	2.0 - 3.0	50					7.0							
38	2.0 - 5.0	50					5.0				5.0	4.5		
50	3.0	50					4.0							

Inch tube [inch]		Minimum straight length to start to bend L1 [mm]	Extra length ~ L [inch] Tube Wall thickness											
Tube Ø	Wall thickness		0.028"	0.035"	0.049"	0.065"	0.083"	0.095"	0.109"	0.120"	0.134"	0.156"	0.188"	
1/4	0.020 - 0.065	40	4.5	5.0	4.0									
3/8	0.020 - 0.095	40		3.5	3.5	4.0	4.0	4.0						
1/2	0.028 - 0.095	50		3.5	3.5	3.5	3.5	3.5						
5/8	0.035 - 0.120	50			4.0	4.0	3.0	4.5	4.0	4.5				
3/4	0.035 - 0.156	50			4.0	4.0	3.0	2.5	3.5	4.0	4.5			
1	0.035 - 0.188	50				3.5	2.5	4.5	4.5	5.0				
1 1/4	0.049 - 0.188	50					4.0	3.0	3.0	3.0	4.0	4.5	4.5	
1 1/2	0.049 - 0.220	50					4.5	4.5	5.0	5.0	5.0	6.0	5.5	
2	0.083 - 0.120	50						4.0	4.0		5.0			

O-Lok® assembly instructions



O-Lok® machine flanging and assembly

- Preferred and
- Most efficient method
- Parflange® recommended



- Parflange® machines:
- Select flaring pin according to tube dimensions
 - Use special "SS" pin for stainless steel tube
 - Pin must be clean and free of wear, damage and metal particles
 - Keep flaring pin clean and lubricate regularly



- Select flanging dies according to tube dimensions
- Use special "SS" dies for stainless steel tube to avoid contact corrosion
- Grip surface must be clean and free of wear
- Use only genuine Parker tooling for flanging O-Lok®



- Load pin into machine
- Ensure lubricating system is filled with oil (1040LUBSS)



- Place sleeve in lower die half
- Locate upper die half onto lower half



- Place the dies in the die housing



- Slide nut onto tube before flanging!
- Open threads towards machine



- ⚠ Press tube firmly into the die against the tube stop



- Pull down the handle to clamp the tube in the dies (1025)
- 1040 die clamping automatic in cycle
- Press button to start flanging cycle
- ⚠ Keep hands clear off the working area



- Parflange® 1025: Unclamp the dies
- Remove tube from machine
- Use die separator to free tube
- Parflange® 1040: Die unclamping is automatic

E

O-Lok® assembly instructions

Checking of flange



- 1**
- Clean flange for inspection
 - ⚠ Check sealing surface for cracks, burrs, scratches and pitting



- 2**
- Dimensional check of the flare
 - Flare O.D. should not exceed outside sleeve diameter
 - Flare O.D. should not be less than smaller diameter of front of sleeve
 - When in doubt, measure

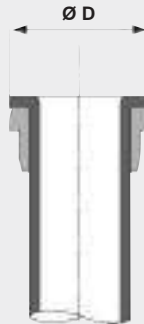

Tube O.D.		Ø D	
mm	In.	min. [mm]	max. [mm]
6	1/4	12.10	12.75
8		14.90	15.75
10	3/8	14.90	15.75
12	1/2	18.00	18.90
14		22.20	23.45
15		22.20	23.45
16	5/8	22.20	23.45
18		26.20	27.80
20	3/4	26.20	27.80
22		32.40	34.20
25	1	32.40	34.20
28		39.00	40.55
30		39.00	40.55
32	1 1/4	39.00	40.55
35		47.00	48.50
38	1 1/2	47.00	48.50
50	2	58.90	60.60

Installation in fitting



- 1**
- Lubricate O-ring
 - Steel fittings:
 - ⚠ No thread lubrication
 - Stainless steel fittings:
 - Lubrication required
 - EO-NIROMONT is a special high-performance lubricant for stainless steel fittings



- 2**
- Thread nut onto body
 - Tighten to full metal contact
 - Mark body and nut as quality check

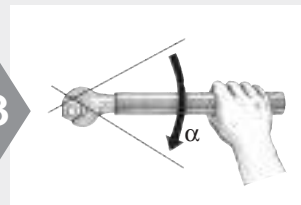

- 3**
- Tighten to recommended torque level
 - Or tighten with spanner the number of flats indicated α
 - Torque method recommended
 - 1 flat = 60°

Tightening recommendation

Metric tube [mm]	Inch tube [inch]	SAE dash size	SAE thread	Assembly torque Nm -0% + 10%		α flats from wrench resistance method*	
				Steel	Stainless Steel	Tube	Swivel nut
6	1/4	-4	9/16-18	25	32	1/4 - 1/2	1/2 - 3/4
8	5/16	-6	11/16-16	40	50	1/4 - 1/2	1/2 - 3/4
10	3/8	-6	11/16-16	40	50	1/4 - 1/2	1/2 - 3/4
12	1/2	-8	13/16-16	65	70	1/4 - 1/2	1/2 - 3/4
14		-10	1-14	80	100	1/4 - 1/2	1/2 - 3/4
15		-10	1-14	80	100	1/4 - 1/2	1/2 - 3/4
16	5/8	-10	1-14	8	100	1/4 - 1/2	1/2 - 3/4
18		-12	1.3/16-12	115	145	1/4 - 1/2	1/3 - 1/2
20	3/4	-12	1.3/16-12	115	145	1/4 - 1/2	1/3 - 1/2
22		-16	1.7/16-12	150	190	1/4 - 1/2	1/3 - 1/2
25	1	-16	1.7/16-12	150	190	1/4 - 1/2	1/3 - 1/2
28		-20	1.11/16-12	190	235	1/4 - 1/2	1/3 - 1/2
30		-20	1.11/16-12	190	235	1/4 - 1/2	1/3 - 1/2
32	1 1/4	-20	1.11/16-12	190	235	1/4 - 1/2	1/3 - 1/2
35		-24	2-12	245	305	1/4 - 1/2	1/3 - 1/2
38	1 1/2	-24	2-12	245	305	1/4 - 1/2	1/3 - 1/2
50	2	-32	2.1/2-12	490	-	-	-

* "Flats From Wrench Resistance" Method for steel and stainless steel

O-Lok® Montageanleitung assembly instructions



O-Lok®: Replacement of O-ring

● Parker CORG assembly tool should be used for O-Lok® fitting with captive O-Ring groove (O-Lok®)



1

● Insert the O-ring into the slot located on the side of the tool



2

● Position the open end of the tool over the tube-end of the fitting



3

● Push the piston of the tool until the O-ring is released into the fitting groove

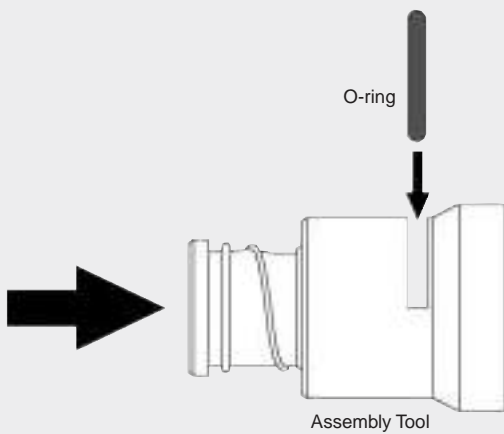

● Function of Parker CORG assembly tool



Triple-Lok® assembly instructions



Tube selection

- Select suitable tube material

Steel tube		Stainless Steel tube
Cold drawn seamless	Welded & redrawn	Cold drawn seamless
NF A 49330	NF A 49341	
ISO 3304 R	DIN2393	NF A 49341
DIN 2391C pt 1	BS 3602/2	DIN 17458 DA/T3
BS 3602 pt1	SAE J525	ASTM A 269
SAE J524		



Tube preparation

- Cut and deburr thoroughly

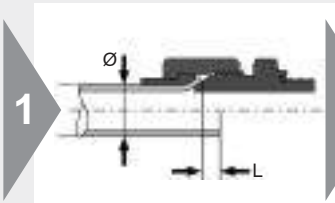

1

- Calculate tube length before cutting
- Add extra length "L"



2

- Minimum length L₁ of straight tube-ends (see chart below)



3

- Cut tube squarely
- max. ±1° deviation
- ⚠ Do not use pipe cutters
- Use tube-cutting tool AV for manual cutting



4

- Remove internal and external burrs
- max. chamfer 0.3mm x 45°
- Recommendation: In-Ex Tube Deburring Tool 226
- ⚠ Proper deburring and cleaning of inner diameter essential for sealing surface quality

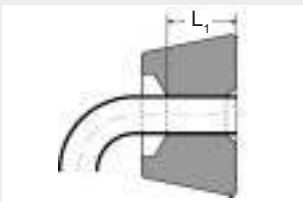

Tube preparation chart

Metric tube [mm]		Inch tube [inch]		extra length ~ L [mm]	Minimum straight length to start to bend L1 [mm]
Tube Ø	Wall thickness	Tube Ø	Wall thickness		
6	1.0 - 1.5	1/4	0.020 - 0.065	2	40
8	1.0 - 1.5	5/16	0.020 - 0.065	2	40
10	1.0 - 1.5	3/8	0.020 - 0.065	2	42
12	1.0 - 2.5	1/2	0.028 - 0.083	2.5	43
14	1.5 - 2.0			2.5	52
15	1.0 - 2.5			2.5	52
16	1.5 - 2.5	5/8	0.035 - 0.095	2.5	52
18	1.5 - 3.0			3	56
20	2.0 - 3.0	3/4	0.035 - 0.109	3	57
22	1.5 - 3.0			3	58
25	2.0 - 3.0	1	0.035 - 0.120	3	58
28	1.5 - 3.0			4	65
30	2.0 - 3.0			4	65
32	2.0 - 3.0	1 1/4	0.049 - 0.120	4	65
35	2.0 - 3.0			4	70
38	2.0 - 4.0	1 1/2	0.049 - 0.120	4	70
42	2.0 - 3.0			5	80
		2	0.058 - 0.134	5	90

Triple-Lok® assembly instructions

Triple-Lok® machine flaring and assembly

- Preferred and
- Most efficient method
- Parflange® recommended



Parflange® machines:

- Select flaring pin according to tube dimensions
- Use special "SS" pin for stainless steel tube
- Pin must be clean and free of wear and damage
- Load tooling into machine
- Keep flaring pin clean and lubricate regularly

- Select flaring dies according to tube dimensions
- Use special "SS" dies for stainless steel tube
- Grip surface must be clean and free of wear
- Use only genuine Parker tooling for flaring Triple-Lok®

- Load tooling into machine
- 1015 flarer: Pin is integrated
- EOMAT: Use flare fixture, pin is integrated
- 1015 flarer and EOMAT: Lubricate flaring pin regularly

- Slide nut and sleeve as shown onto the tube-end



- ⚠ Press tube firmly into the die against the tube stop
- Parflange® 1025/1040: Clamp tube
- 1015 flarer: Close valve on handpump
- Flaring pin must be lubricated using 1040LUBSS

- Hold tube firmly
- Parflange® 1025/1040: Press start button
- 1015 flarer: Operate handpump until correct flaring pressure is reached
- EOMAT II/III: Press and hold start button
- ⚠ Keep hands clear off the working area

- 1015 flarer: Open valve on handpump
- Parflange® 1025: Unclamp the dies
- Parflange® 1040: Die unclamping is automatic
- Remove tube from machine
- Use die separator to free tube

E

Triple-Lok® assembly instructions

Checking of flange



- Clean flare for inspection
- ⚠ Check sealing surface for cracks, burrs, scratches and pitting

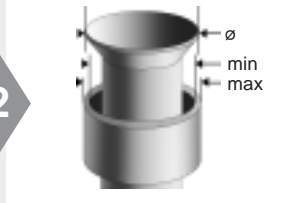

- Dimensional check of the flare
- Flare O.D. should not exceed outside sleeve diameter
- Flare O.D. should not be less than smaller diameter of front of sleeve
- When in doubt, measure

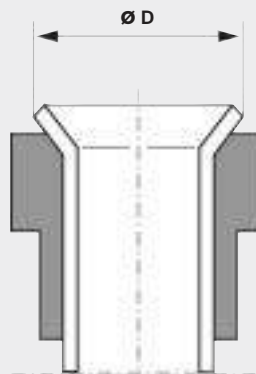

Tube O.D.		ø D	
mm	inch	Min.	Max.
6	1/4"	8	9.7
8	5/16"	9.5	11.3
10	3/8"	11.2	12.7
12	1/2"	14.9	17.3
14		17.9	20.2
15		17.9	20.2
16	5/8"	17.9	20.2
18		22.3	24.7
20	3/4"	22.3	24.7
22	7/8"	25.5	27.8
25	1"	28.7	31
28		35.8	38.9
30		35.8	38.9
32	1.1/4"	35.8	38.9
35		41.4	45.3
38	1.1/2"	41.4	45.3
42	2"	50.9	54.8
		55.8	61.2

Installation



- Steel fittings: No lubrication
- ⚠ Stainless steel fittings: Lubrication required
- Use EO-NIROMONT special high-performance lubricant for stainless steel fittings



- Thread nut onto body
- Tighten to full metal contact (finger tight)
- Mark body and nut as quality check
- Tighten with spanner the number of flats indicated

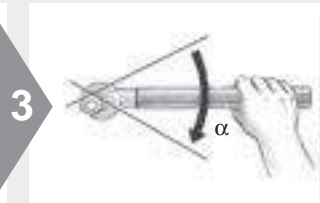

- Use EO-NIROMONT lubricant for stainless steel fittings
- Use spanner extension for larger fittings (28mm+)

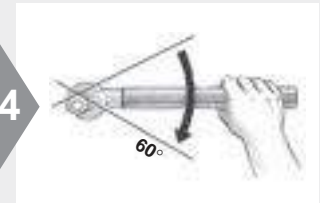

- 1 flat = 60°

Tightening recommendation

Metric tube [mm]	Inch tube [inch]	SAE thread	α flats from finger tight method*		Assembly torque* Nm -0% + 10%	
			tube	Swivel nut	steel	stainless steel
6	1/4	7/16-20	2	2	15	30
8	5/16	1/2-20	2	2	20	40
10	3/8	9/16-18	1.1/2	1.1/4	30	60
12	1/2	3/4-16	1.1/2	1	60	115
14		7/8-14	1.1/2	1	75	145
15		7/8-14	1.1/2	1	75	145
16	5/8	7/8-14	1.1/2	1	75	145
18		1.1/16-12	1.1/4	1	110	180
20	3/4	1.1/16-12	1.1/4	1	110	180
22	7/8	1.3/16-12	1	1	135	225
25	1	1.5/16-12	1	1	175	255
28		1.5/8-12	1		260	295
30		1.5/8-12	1	1	260	295
32	1.1/4	1.5/8-12	1	1	260	295
35		1.7/8-12	1		340	345
38	1.1/2	1.7/8-12	1	1	340	345
42		2.1/4-12	1	1	380	400
	2	2.1/2-12	1	1	450	470

* "Flats From Finger Tight" Method for steel and stainless steel

Checking instructions for O-Lok® / Triple-Lok® tools



Tools for Parflange® machines

- ⚠ Use of damaged, worn or non-suitable tooling may result in fitting failure and damage of machine
- ⚠ Tools must be checked regularly, at least after 50 assemblies
- ⚠ Worn tools must be replaced
- ⚠ Use only genuine Parker tools
- ⚠ Tools must always be kept clean and lubricated

1



- Clean pin for checking

2



- Visual check:
Surface must be free of wear and damage

3



- Clean die halves for checking
- ⚠ Do not disassemble
- Fixing pins must not be loose or damaged

4



- Visual check:
Grip surface must be clean and free of wear
- Use wire-brush to remove metal particles from grip surface



Adjustment of Parflange® dies

- Parflange® dies can be adjusted to correct deviations of flare diameter
- ⚠ Re-adjustment of dies will not help if general machine setting is incorrect or components are damaged (worn tube-stop, lose screw connections)

1



- To reduce the flare diameter, turn the screws anti-clockwise
- ⚠ Re-adjust both screws simultaneously

2



- To increase the flare diameter, turn the screws clockwise
- ⚠ Re-adjust both screws simultaneously

3



- Adjust the screws in small stages
- Then check flare diameter
- ⚠ Lock screws to prevent misadjustment

Flange-Seal assembly instructions



Tube selection

- Select suitable tube material

Steel tube

Cold drawn seamless	Welded & redrawn
NF A 49330	NF A 49341
ISO 3304 R	DIN2393
DIN 2391C pt 1	BS 3602/2
BS 3602 pt1	SAE J525
SAE J524	



Tube preparation

- Cut and deburr thoroughly

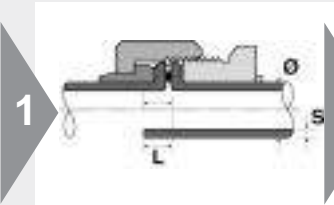

1

- Calculate tube length before cutting
- Add extra length "L" (see chart below)



2

- Minimum length of straight tube-ends (see chart below)



3

- Cut tube squarely
- max. $\pm 1^\circ$ deviation
- ⚠ Do not use pipe cutters
- Use tube-cutting tool AV for manual cutting



4

- Remove internal and external burrs
- max. chamfer 0.3mm x 45°
- Recommendation: In-Ex Tube Deburring Tool 226
- ⚠ Proper deburring and cleaning of inner diameter essential for sealing surface quality

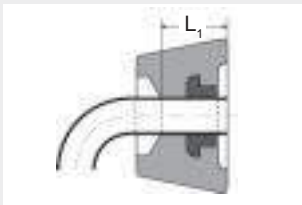

Metric tube [mm]		Minimum straight length to start to bend L1 [mm]	Extra length ~ L [mm] for tube wall thickness							
Tube Ø	Wall thickness		1	1.5	2	2.5	3	3.5	4	
6	1.0 - 1.5	50	4.5	5.5						
8	1.0 - 2.0	50	5.0	5.0						
10	1.0 - 2.0	50	2.5	4.0	3.5					
12	1.0 - 2.5	50	3.5	4.5	4.5	4.0				
16	1.5 - 3.0	50		3.0	3.0	3.0	2.5			
20	2.0 - 3.5	65			3.5	4.0	4.0	3.5		

Inch tube [inch]		Minimum straight length to start to bend L1 [mm]	Extra length ~ L [mm] for tube wall thickness [inch]										
Tube Ø	Wall thickness		0.028"	0.035"	0.049"	0.065"	0.083"	0.095"	0.109"	0.120"	0.134"	0.156"	0.188"
1/4	0.020 - 0.065	40	4.5	5.0	4.0								
3/8	0.020 - 0.095	40		3.5	3.5	4.0	4.0	4.0					
1/2	0.028 - 0.095	50		3.5	3.5	3.5	3.5	3.5					
5/8	0.035 - 0.120	50			4.0	4.0	3.0	4.5	4.0	4.5			
3/4	0.035 - 0.134	50			4.0	4.0	3.0	2.5	3.5	4.0	4.5		

Flange-Seal assembly instructions



Parflange® 1040



Parflange® 1025

Flange-Seal machine flanging and assembly

- Preferred and
- Most efficient method
- Parflange® recommended

1



Parflange® machines:

- Select flaring pin according to tube dimensions
- Use standard O-Lok® pins
- Pin must be clean and free of wear, damage and metal particles
- Keep flaring pin clean and lubricate regularly

2



- Select flanging dies according to tube dimensions
 - Use special Flange-Seal dies
 - Grip surface must be clean and free of wear
 - Use only genuine Parker tooling for flanging
- ⚠ Note limitation on wall thickness for tube-tube connections

3



- Load pin into machine
- Ensure lubricating system is filled with oil (1040LUBSS)

4



- Place threaded sleeve (LHP) in lower die half
- Locate upper die half onto lower half

5



- Place the dies in the die housing

6



- ⚠ Press tube firmly into the die against the tube stop

7



- Pull down the handle to clamp the tube in the dies (1025)
 - 1040 die clamping automatic in cycle
 - Press button to start flanging cycle
- ⚠ Keep hands clear of the working area

E

Flange-Seal assembly instructions

9



- Parflange® 1025:
Unclamp the dies
- Remove tube from machine
- Use die separator to free tube
- Parflange® 1040:
Die unclamping is automatic

10



- Clean flange for inspection
- ⚠ Check sealing surface for cracks, burrs, scratches and pitting

11

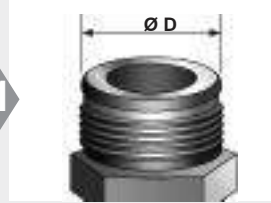

- Dimensional check of the flare

Tube O.D.		Ø D	
mm	In.	min. [mm]	max. [mm]
6	1/4	12.10	12.75
8		14.90	15.75
10	3/8	14.90	15.75
12	1/2	18.00	18.90
16	5/8	22.20	23.45
20	3/4	26.20	27.80

12



- Place seal into loose tube nut
- Tighten to full metal contact
- Tighten to recommended torque level

Tightening recommendation

Metric tube [mm]	Inch tube [inch]	SAE dash size	SAE thread	Assembly torque Nm -0% + 10% Steel
6	1/4	-4	9/16-18	25
8		-6	11/16-16	40
10	3/8	-6	11/16-16	40
12	1/2	-8	13/16-16	65
16	5/8	-10	1-14	80
20	3/4	-12	1.3/16-12	115

System component guide - Flange-Seal system - Metric tubes

Tube O.D. (mm)	Con. dash size	Flange-Seal fitting	Seal element	Die tool*	Pin tool
6	4	LHMPS6	4PLS	M4018006XxxxMLHP	B3018006XxxxM
8	6	LHMPS8	6PLS	M4018008XxxxMLHP	B3018008XxxxM
10	6	LHMPS10	6PLS	M4018010XxxxMLHP	B3018010XxxxM
12	8	LHMPS12	8PLS	M4018012XxxxMLHP	B3018012XxxxM
16	10	LHMPS16	10PLS	M4018016XxxxMLHP	B3018016XxxxM
20	12	LHMPS20	12PLS	M4018020XxxxMLHP	B3018020XxxxM

*xxx: Insert tube wall thickness according to tooling list
 *Example 1: Metric tube tooling for 8x1.5mm
 Die: M4018008x1.5MLHP Pin: B3018008x1.5M

System component guide - Flange-Seal system - Inch tubes

Tube O.D. (inch)	Con. dash size	Flange-Seal fitting	Seal element	Die tool*	Pin tool
1/4	4	4LHP-S	4PLS	M4004Xxxx180LHP	B4004Xxxx180
3/8	6	6LHP-S	6PLS	M4006Xxxx180LHP	B4006Xxxx180
1/2	8	8LHPS	8PLS	M4008Xxxx180LHP	B4008Xxxx180
5/8	10	10LHP-S	10PLS	M4010Xxxx180LHP	B4010Xxxx180
3/4	12	12LHP-S	12PLS	M4012Xxxx180LHP	B4012Xxxx180

*xxx: Insert tube wall thickness according to tooling list
 *Example 2: Inch tube tooling for 1/2x0.083"
 Die: M4008x083180LHP Pin: B4008x083180



Fitting assembly



Table of contents

Port connections M	F4
Port connections BSPP	F5
Port connections UNF	F6
Port connections TAPER	F7
Adjustable fittings with locknut.....	F8
EO swivels	F9
Triple-Lok® / O-Lok® swivels	F10
Flanges	F11
Replacement / DA	F12
Tube bending	F13
Tube line fabrication guide	F14



Port connections

Assembly of metric straight port connections



- Metric Thread
DIN ISO 6149-2/3
ISO 9974-2/3
DIN 3852 T1/T2

1



2



3

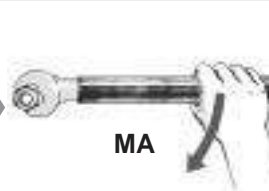

- ⚠ Threads of stainless steel fittings must be lubricated
- EO-NIROMONT is a special high-performance lubricant for stainless steel fittings
- Screw in until handtight
- Then tighten according to chart

Assembly torques for metric threads

Product Series	Tube O.D.	Thread size T mm	Straight male stud fittings with port tapping					O-ring with sealing and retaining-ring	Non-return valves RHV/RHZ Form E with ED-sealing Nm	EO Banjo fittings		Adjustable ends		Blanking plugs	
			Form A for sealing washer Nm	Form B with face Nm	Form E with ED-sealing Nm	Form F with O-ring-sealing Nm	WH / TH Nm			SWVE Nm	O-ring and retaining-ring Nm	O-ring Nm	VSTI-ED Form E with ED-sealing Nm	VSTI-OR Form F with O-ring sealing Nm	
EO L Triple-Lok®	6	M10 x 1.0	9	18	18	15	18	18	18	18	18	15	12	20	
	8	M12 x 1.5	20	30	25	25	35	25	45	35	35	25	25		
	10	M14 x 1.5	35	45	45	35	45	35	55	50	45	35	35		
	12	M16 x 1.5	45	65	55	40	55	50	80	60	55	40	50		
	15	M18 x 1.5	55	80	70	45	70	100	80	70	45	65	65		
	18	M22 x 1.5	65	140	125	60	160	125	140	120	180	60	90		
	22	M27 x 2.0	90	190	180	100	250	145	320	130	180	100	135		
	28	M33 x 2.0	150	340	310	160	310	210	360		310	160	225		
	35	M42 x 2.0	240	500	450	210	450	360	540		450	210	360		
	42	M48 x 2.0	290	630	540	260	540	540	700		600	260	360		
EO S O-Lok®	6	M12 x 1.5	20	35	35	35		35	45	35	35	35		35	
	8	M14 x 1.5	35	55	55	45		45	55	50	60	45		45	
	10	M16 x 1.5	45	70	70	55		55	80	60	95	55		55	
	12	M18 x 1.5	55	110	90	70		70	100	80	120	90		70	
	14	M20 x 1.5	55	150	125	80		100	125	110			80	80	
	16	M22 x 1.5	65	170	135	100		125	135	120	190	100		100	
	20	M27 x 2.0	90	270	180	170		135	320	135	190	170		170	
	25	M33 x 2.0	150	410	310	310		210	360		500	310		310	
	30	M42 x 2.0	240	540	450	330		360	540		600	330		330	
	38	M48 x 2.0	290	700	540	420		540	700		600	420		420	

Tolerance of tightening torques listed in above table: +10%
 Note: Lubricate stud with hydraulic oil before screwing in! Tightening torques relate to counterpart made of steel.

Port connections

Assembly of BSPP straight port connections

- BSPP thread G
ISO 1179-1
DIN 3852 T2

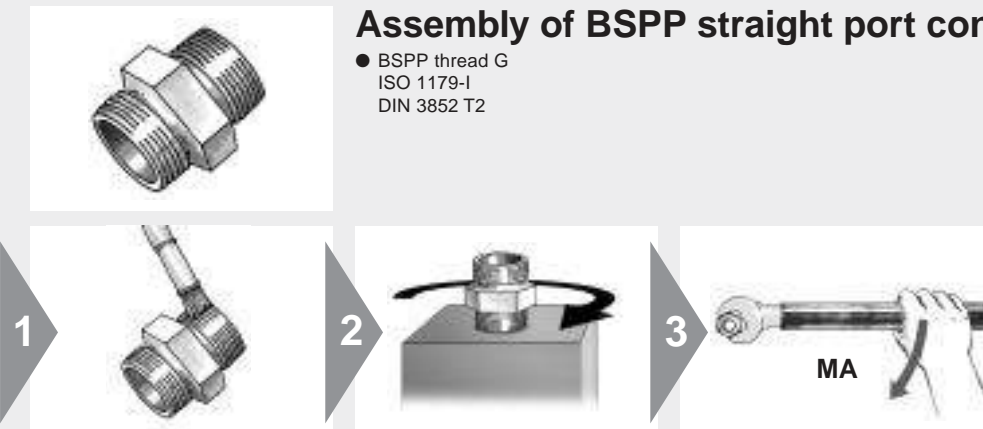

- ⚠ Threads of stainless steel fittings must be lubricated
- EO-NIROMONT is a special high-performance lubricant for stainless steel fittings
- Screw in until handtight
- Then tighten according to chart

Assembly torques for BSPP threads

Product Series	Tube O.D.	Thread size T inch	Straight male stud fittings with port tapping				Non-return valves RHV / RHZ Form E with ED-sealing	EO Banjo fittings		Adjustable ends O-ring and retaining-ring Nm	Blanking plugs Form E with ED-sealing Nm
			Form A for sealing washer Nm	Form B with cutting face Nm	Form E with ED-sealing Nm	with O-ring sealing and retaining-ring		WH / TH Nm	SWVE Nm		
EO L Triple-Lok®	6	G 1/8A	9	18	18	18	18	18	18	18	13
	8	G 1/4A	35	35	35	35	35	45	40	35	30
	10	G 1/4A	35	35	35	35	35	45	40	35	
	12	G 3/8A	45	70	70	70	50	70	65	70	60
	15	G 1/2A	65	140	110	90	85	120	90	110	80
	18	G 1/2A	65	100	110	90	65	120	90	110	
	22	G 3/4A	90	180	180	180	140	230	125	180	140
	28	G 1A	150	330	310	310	190	320		310	200
	35	G 1 1/4A	240	540	450	450	360	540		450	400
42	G 1 1/2A	290	630	540	540	540	700		540	450	
EO S O-Lok®	6	G 1/8A								25	
	6	G 1/4A	35	55	55		45	45	40	55	
	8	G 1/4A	35	55	55		45	45	40	55	
	10	G 3/8A	45	90	80		60	70	65	90	
	12	G 3/8A	45	90	80		60	70	65	90	
	14	G 1/2A	65	150	115		145	120	90	110	
	16	G 1/2A	65	130	115		100	120	90	110	
	20	G 3/4A	90	270	180		145	230	125	115	
	25	G 1A	150	340	310		260	320		420	
	30	G 1 1/4A	240	540	450		360	540		550	
38	G 1 1/2A	290	700	540		540	700		600		

Tolerance of tightening torques listed in above table: +10%
 Note: Lubricate stud with hydraulic oil before screwing in! Tightening torques relate to counterpart made of steel.

Port connections

Assembly of SAE straight port connections

- UN/UNF thread
ISO 11926-2/3



1



2



3



⚠ Threads of stainless steel fittings must be lubricated

- EO-NIROMONT is a special high-performance lubricant for stainless steel fittings

● Screw in until handtight

● Then tighten according to chart

Assembly torques for UNF threads

Product	Thread size T ISO 11296	Series EO / Triple-Lok® and O-Lok®	
		Assembly torque non-adjustable end Nm	Assembly torque adjustable end Nm
Series	inch		
EO L Triple-Lok®	7/16-20 UN(F)	23	18
	1/2-20 UN(F)	28	28
	9/16-18 UN(F)	34	34
	3/4-16 UN(F)	60	55
	7/8-14 UN(F)	115	80
	1.1/16-12 UN(F)	140	100
	1.5/16-12 UN(F)	210	150
	1.5/8-12 UN(F)	290	290
EO S O-Lok®	1.7/8-12 UN(F)	325	325
	7/16-20 UN(F)	20	20
	1/2-20 UN(F)	40	40
	9/16-18 UN(F)	46	46
	3/4-16 UN(F)	80	80
	7/8-14 UN(F)	135	135
	1.1/16-12 UN(F)	185	185
	1.5/16-12 UN(F)	270	270
1.5/8-12 UN(F)	340	340	
	1.7/8-12 UN(F)	415	415

Tolerance of tightening torques listed in above table: + 10%
 Note: Lubricate stud with hydraulic oil before screwing in!
 Tightening torques relate to counterpart made of steel.

Port connections

Assembly of tapered thread port connections

- NPT / NPTF thread
ANSI / ASME B 1.20.1 - 1983



1



2



3

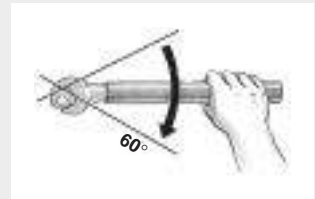
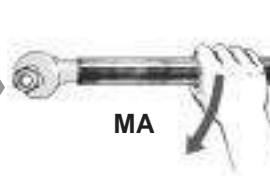

⚠ Threads of stainless steel fittings must be lubricated

- EO-NIROMONT is a special high-performance lubricant for stainless steel fittings

● Screw in until handtight

● Then tighten according to chart

● one flat = 60°

Tightening of NPT/NPTF thread

Size	Thread	Assembly TFFT
	T NPT/F	
4	1/8-27 NPT/F	2.0-3.0
6	1/4-18 NPT/F	2.0-3.0
8	3/8-18 NPT/F	2.0-3.0
10	1/2-14 NPT/F	2.0-3.0
12	3/4-14 NPT/F	2.0-3.0
16	1-11 1/2 NPT/F	1.5-2.5
20	1 1/4-11 1/2 NPT/F	1.5-2.5
24	1 1/2-11 1/2 NPT/F	1.5-2.5

In the EO fitting range only **NPT** thread is manufactured.

In the **Triple-Lok®** and **O-Lok®** fitting range for **steel NPTF** thread is manufactured and for stainless steel NPT thread is manufactured.

F

Adjustable fittings with locknut



Assembly of the orientable joint

(EO: e.g. WEE, VEE, TEE, LEE - Triple-Lok® / O-Lok®: C4, V4, S4, R4)

⚠ Assembly steps must be done in right order

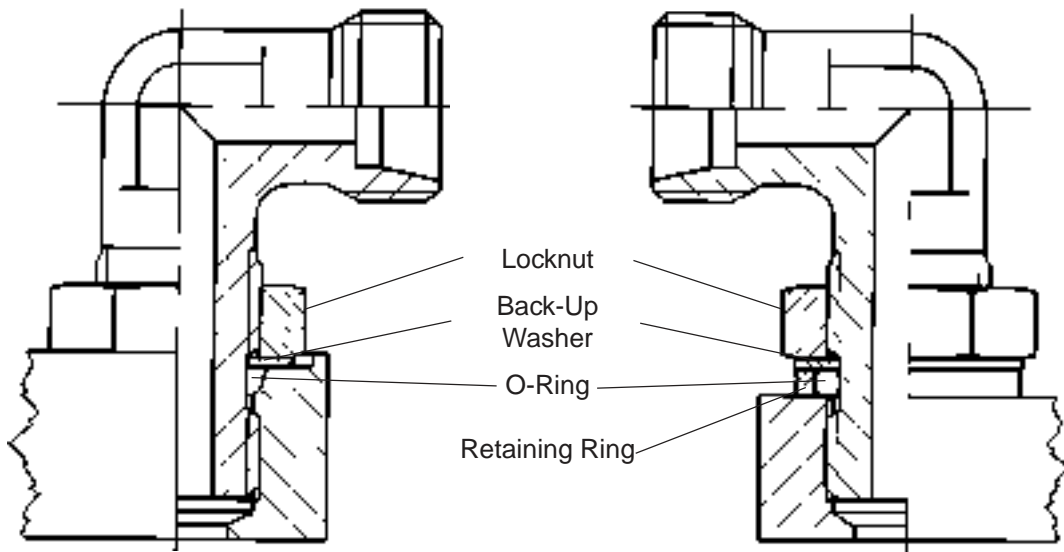

● Fitting *without* Retaining Ring for ISO 6149 or UN/UNF ports

● Fitting *with* Retaining Ring for BSPP or Metric Parallel ports with wide or **SMALL** spot faces

1



● Screw back locknut as far as possible

⚠ O-ring and back-up washer in the non-threaded section should be placed nearest to the locknut

● Lubricate the O-ring
● With BSPP and metric parallel version slip retaining ring over the O-ring



2



● Screw the fitting in the port by hand until retaining ring or back-up washers bottom



3



● To adjust direction, turn back to a maximum of one full turn

4



● Screw locknut handtight
● Assemble locknut until wrenchtight
● Hold body in desired position and tighten locknut



EO swivels



Assembly of EO swivel nut fittings

(e.g. EW, ET, EL, EGE, RED, VKA, SKA)

- Final assembly of swivel nut fittings must be made in appropriate fittings

1



- ⚠ Threads of stainless steel fittings must be lubricated
- EO-NIROMONT is a special high-performance lubricant for stainless steel fittings

2



- Screw on nut by hand until handtight

3



- ⚠ Then tighten fitting firmly by 1/4 turn (1 1/2 flats)



Final assembly of factory pre-assembled EO-standpipe fittings

(e.g. EVW, EVT, EVL, EVGE, KOR)

- For all fittings delivered pre-assembled from the factory the final assembly is performed in the appropriate fitting body

1



- ⚠ Threads of stainless steel fittings must be lubricated
- EO-NIROMONT is a special high-performance lubricant for stainless steel fittings

2

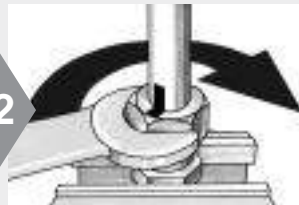

- Assemble fitting until wrench tight (without spanner extension)
- ⚠ Mark position of nut

3

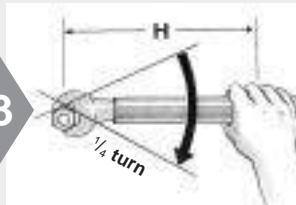

- ⚠ Then tighten fitting firmly by 1/4 turn (1 1/2 flats)
- ⚠ Recommended to use spanner extension for sizes over 20 mm O.D. (see chart)

Spanner length

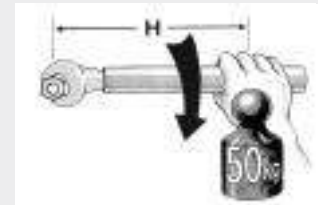

Size	Spanner length H [mm]
18-L 16-S	300
22-L	400
28-L 20-S	500
35-L 25-S	900
42-L 30-S	1200
38-S	1500

Triple-Lok®/O-Lok® swivels



Assembly of Triple-Lok® and O-Lok® swivel nut fittings

e.g.: Triple-Lok®: C6MX, V6MX, R6MX, S6MX, BBMTX

O-Lok®: C6MLO, V6MLO, S6MLO, R6MLO, A0EL6

● Final assembly of swivel nut fittings must be made in appropriate fittings

1



2



3

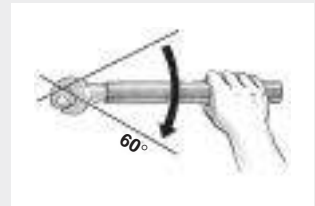
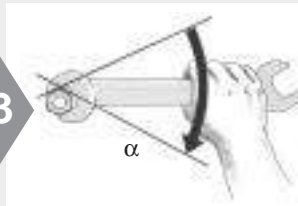

⚠ Threads of stainless steel fittings must be lubricated

- EO-NIROMONT is a special high-performance lubricant for stainless steel fittings

● Screw on nut by hand until handtight

● Then tighten according to chart

● one flat = 60°

Assembly torques for Triple-Lok® and O-Lok® swivel nut fittings

O-Lok®

Size	Metric tube mm	Inch tube inch	Thread UN/UNF	Nm	FFWR
4	6	1/4	9/16-18	25	1/2
6	8	5/16	11/16-16	40	1/2
6	10	5/16	11/16-16	55	1/2
8	12	1/2	13/16-16	80	1/2
10	14, 15, 16	5/8	1-14	115	1/2
12	18, 20	3/4	1.3/16-12	130	1/2
16	22, 25	1	1.7/16-12	150	1/2
20	28, 30, 32	1 1/4	1.11/16-12	190	1/2
24	35, 38	1 1/2	2-12	245	1/2
32	50	2	2.1/2-12	490	1/2

Triple-Lok®

Size	Metric tube mm	Inch tube inch	Thread UN/UNF	Nm	FFFT
4	6	1/4	7/17-20	15	2
5	8	5/16	1/2-20	20	2
6	10	3/8	9/16-18	45	1 1/4
8	12	1/2	3/4-16	60	1
10	14, 15, 16	5/8	7/8-14	75	1
12	18, 20	3/4	1.1/16-12	100	1
16	22, 25	7/8, 1	1.5/16-12	150	1
20	30, 32	1 1/4	1.5/8-12	180	1
24	38	1 1/2	1.7/8-12	200	1
28	42		2.1/4-12	220	1
32		2	2.1/2-12	250	1

Assembly torques shown in chart are for **non-lubricated carbon steel zinc plated components**.

For stainless steel fittings, lubricate all mating surfaces and tighten to upper end of torque tolerance.

Recommended assembly torques are for connections consisting of all Parker manufactured components.

Flanges



Assembly of flanges

- SAE flange adapters
- SAE 4 bolt flanges
- Gear pump flanges
- CETOP square flanges

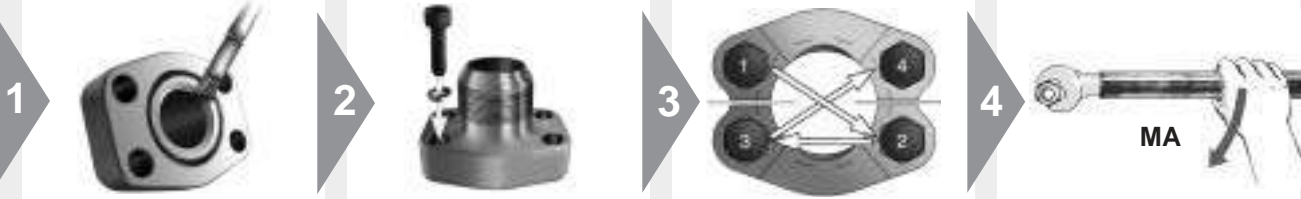

- Make sure sealing surfaces are free of burrs, nicks, scratches or any contamination
- Lubricate the O-ring with system fluid or compatible lubricant
- Position flange and clamp halves
- Place lock washers on bolts and bolt through clamp halves
- Hand tighten bolts
- Torque bolts in diagonal sequence in small increments to the appropriate torque level listed in chart
- Tighten bolts according to chart

3000 PSI Series (Code 61) Flange recommended screws torque

Dash size	Flange size	Inch screws (J518)	Torque Nm ¹⁾	Metric screws (ISO 6162)	Torque Nm ¹⁾
8	1/2	5/16-18	17 ± 2	M8	24
12	3/4	3/8-16	25 ± 4,5	M10	50
16	1	3/8-16	31 ± 4,5	M10	50
20	1-1/4	7/16-14	41 ± 5	M12*	50
24	1-1/2	1/2-13	52 ± 6	M12	42
32	2	1/2-13	60 ± 6	M14*	135
40	2-1/2	1/2-13	85 ± 9	M12	92
48	3	5/8-11	144 ± 15	M16	210
56	3-1/2	5/8-11	125 ± 8	M16	210
64	4	5/8-11	125 ± 8	M16	210
80	5	5/8-11	125 ± 8	M16	210

*Does not meet ISO 6162 specification

6000 PSI Series (Code 62) Flange recommended screws torque

Dash size	Flange size	Inch screws (J518)	Torque NM ¹⁾	Metric screws (ISO 6162)	Torque Nm ¹⁾
8	1/2	5/16-18	24	M8	24
12	3/4	3/8-16	43	M10	50
16	1	7/16-14	70	M12	92
20	1-1/4	1/2-13	105	M14*	130
24	1-1/2	5/8-11	210	M16	210
32	2	3/4-10	310	M20	400

*Does not meet ISO 6162 specification

Hydraulic Flange recommended screws torque

Socket screw bolt circle (LK)	Socket head cap screws	Tightening torques Nm ¹⁾
LK30	M6	10
LK35	M6	10
LK40	M6	10
LK51	M10	49
LK55	M8	25
LK56	M10	49
LK62	M10	49
LK72.5	M12	85

1) Tolerances: max. 10%
min. 0%

Replacement of an EO Bite type connection



Distance piece adapter DA

- EO distance piece adapters allow replacement bite type connections on existing pipework easily or retrofitting using EO-2
- The existing tubes can be re-used

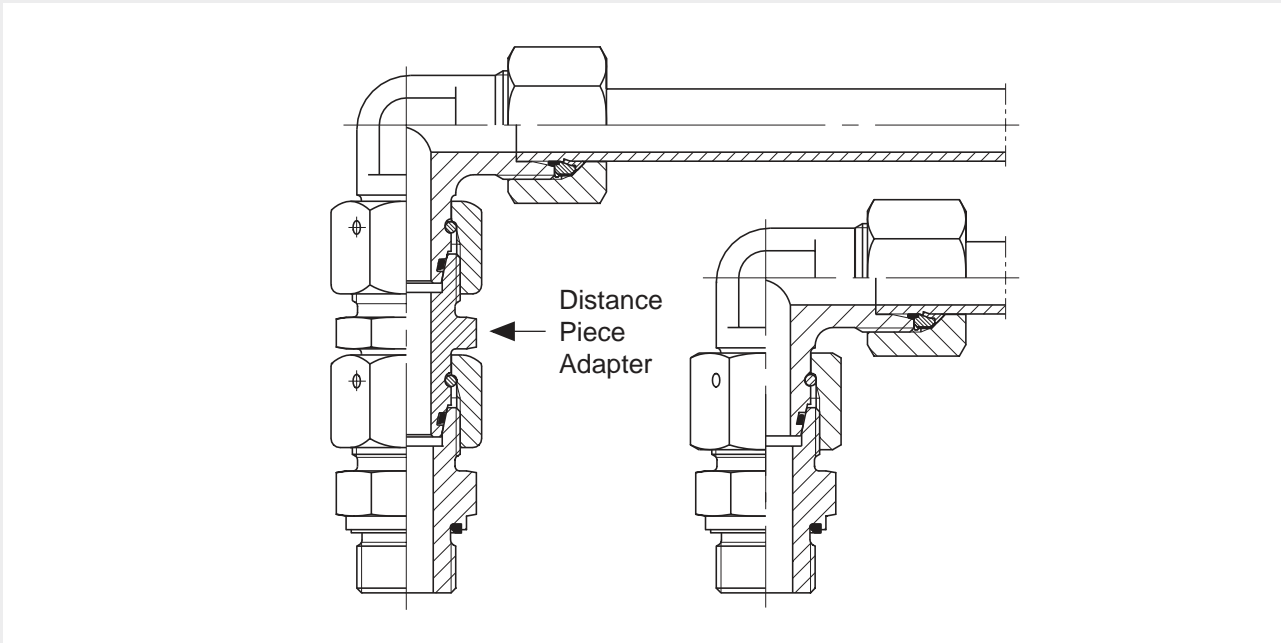

- Use as an extension for stacked assemblies



- 1
- Cut length L off tube-end (see "DA" chapter I)
 - Scrap obsolete nut

- 2
- Assemble new EO-2 functional nut or EO PSR/DPR and nut

- 3
- Thread on
 - Then tighten distance piece adapter onto tube-end

Tube bending

Instructions for EO hand bending equipment

- For on-site piping jobs
- Not for mass production

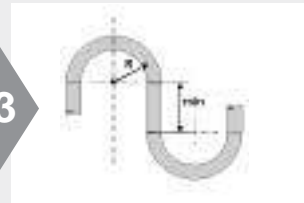

- ⚠ Think the whole process through and plan each individual step before starting
- ⚠ First bend and then cut ends to length
- Gather all dimensions like minimum straight lengths, extra length for flaring, bending radius, tube lengths for bows, etc.

- Consider steps
- Plan for clamping

- Check bending equipment specifications for limitations

- Start with first elbow
- Leave tube-end longer if in doubt

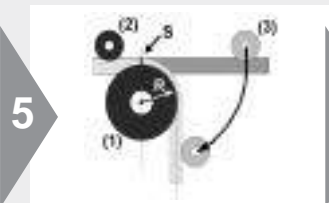

- ⚠ Mark start of bend on tube (S)
- Adjust tube between bending roll (1), clamping roll (2) and pressure roll (3)
- Bend tube by pulling lever

- Check for angularity
- Correct angle if necessary
- Gather all dimensions for next bending operation

- ⚠ Mark start of bend on tube
- Continue bending
- Check and correct each result before starting next bend

- After the last bend, check tube for angularity and dimensions
- Now cut both tube-ends to correct length
- Make sure that tube fits without tension

F

Tube line fabrication guide for leak free systems

Every hydraulic, pneumatic and lubrication system requires some form of tube fabrication and fitting installation for completion. Proper fabrication and installation are essential for the overall efficiency, leak free performance, and general appearance of any system.

After sizing the tube lines and selecting the appropriate style of fitting, consider the following in the design of your system:

1. Accessibility of joints
2. Proper routing of lines
3. Adequate tube line supports
4. Available fabricating tools

- Keep tube lines away from components that require regular maintenance:

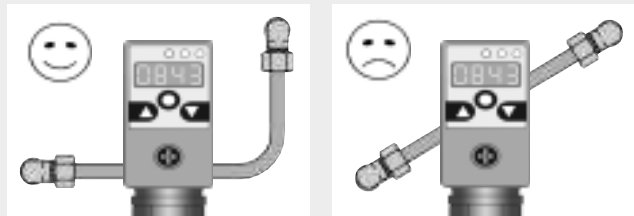

- Right-angled – parallel – clear
- Have a neat appearance and allow for easy trouble-shooting, maintenance and repair:

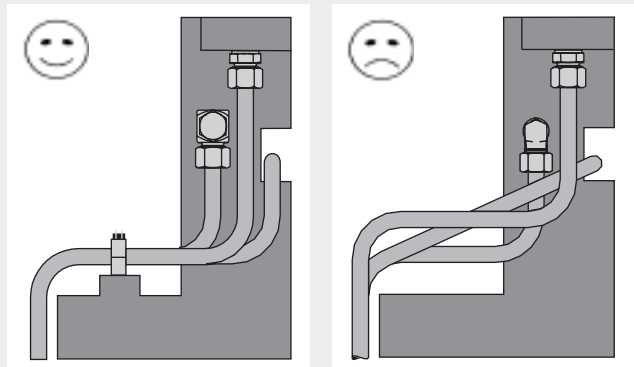

- Example for tube to hose connection:

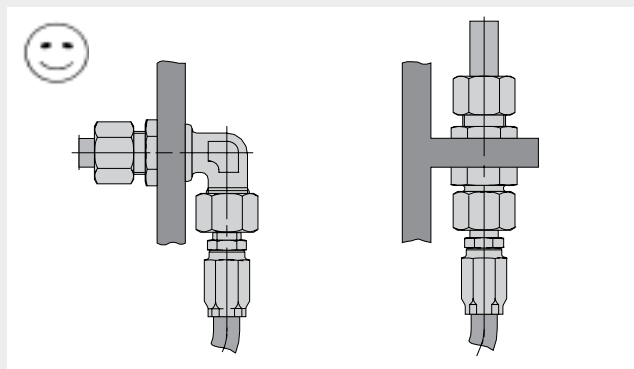

Tube line fabrication guide for leak free systems

- Do not use tube lines to support other tubes
- Always fix tubes onto a rigid point with tube clamps
- Do not use cable channels to support tubes

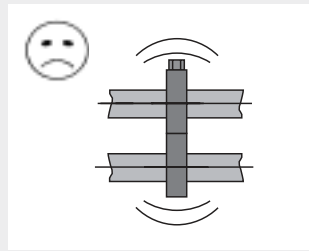
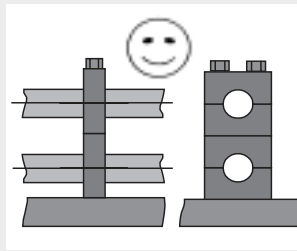

- Use appropriate tube clamps:

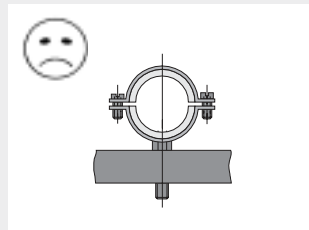
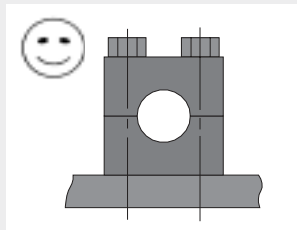

- Avoid excessive strain on joint:
A strained joint will eventually leak

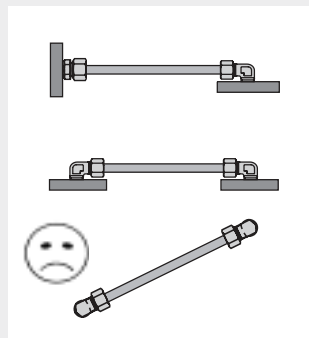
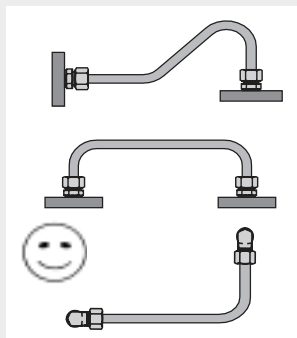

- Allow for expansion effects

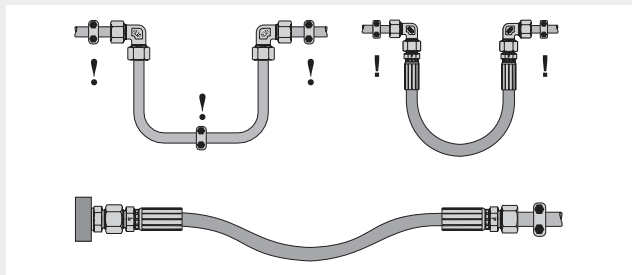

- Avoid short tube length:
- ⚠ Short tube lengths increase chance of fatigue fractures
- Use adapter GZR or swivel connector for swivel fittings instead of short tube lengths

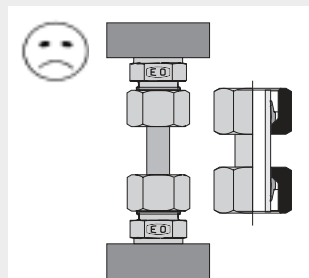
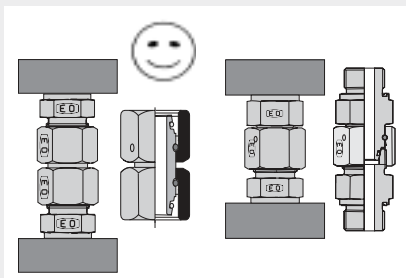

F

Tube line fabrication guide for leak free systems

- Support against actuating forces:

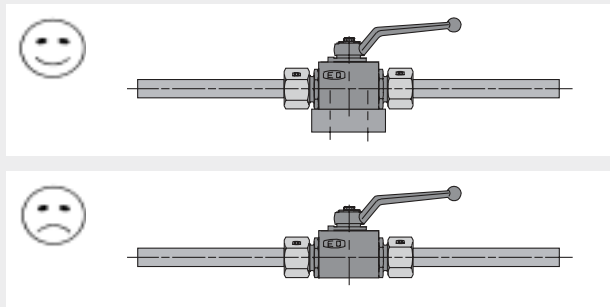

Recommended tools for tube line fabrication:

Cutting:

EO Tube cutting tool AV

EO Combined tube bending and cutting tool BAV

Tube cutters:

Steel: Type Kloskut;

Stainless Steel: Type 635 B-EX,

Type 218 B-SS Tru-Kut Sawing Vice

Deburring:

Parker deburring tool no. 226 DEBURR

Bending:

EO Combined tube bending and cutting tool BAV

EO Tube bending tool BV 6/18, BV 20/25

EO Tube bending tool BVP (programmable)

Tube lines have to be supported in certain distances:

Use sufficient tube clamps to support weight

Use sufficient tube clamps to protect joints from vibration

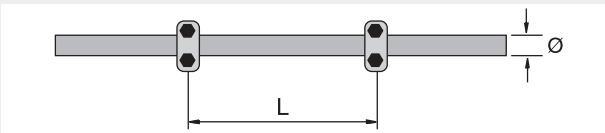

Tube O. D. [mm]	L [m]
6,0 – 12,7	1,0
12,7 – 22,0	1,2
22,0 – 32,0	1,5
32,0 – 38,0	2,0
38,0 – 57,0	2,7
57,0 – 75,0	3,0
75,0 – 76,1	3,5
76,1 – 88,9	3,7
88,9 – 102,0	4,0
102,0 – 114,0	4,5
114,0 – 168,0	5,0
168,0 – 219,0	6,0

Vibration has to be eliminated near by the connectors:

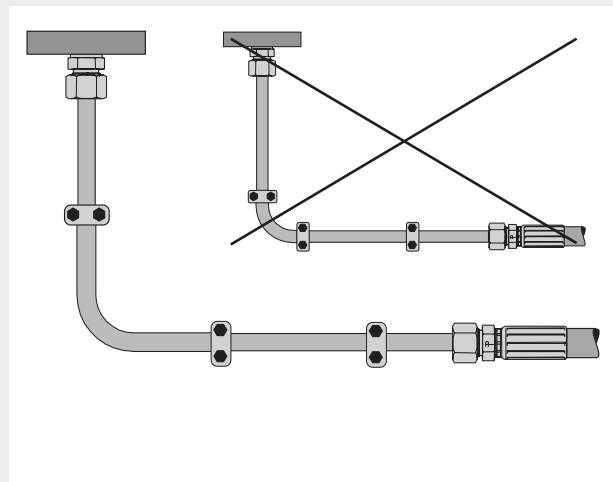

Allow expansion and contraction. Do not hamper expansion and contraction near by tube bends:

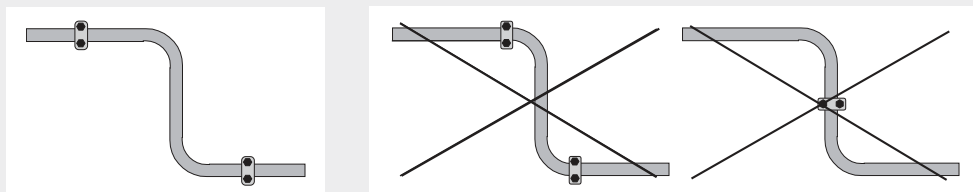



Trouble shooting guide

Trouble shooting

DPR/PSR Problem	Probable cause	Suggested solution
Leak	Insufficiently tightened, shallow bite	Tighten the nut according to correct number of turns, direct assembly only for maintenance/repair
		Use correct spanners and spanner extensions especially for larger sizes and stainless steel fittings, use of recommended pre-assembly machines
		Mark nut and body to indicate correct assembly
		Use recommended lubrication
		Use of pre-assembly machines e.g. EO-KARRYMAT, EOMAT II, EOMAT III/A
		Pre-assemble joints away from installation to ensure proper bite
		Check visible collar
	Tube not bottomed into fitting shoulder	Cut tube to correct length
		Observe min. straight length before tube bend
		Use hacksaw and guide not a plumbing – style tube cutter
		Carefully deburr tube end – no heavy chamfers
		Push tube firmly into cone
		Check visible collar
	Damaged fitting	Check for damage, replace damaged parts
		Handle all components carefully
Contamination between sealing surfaces	Keep all components clean	
Hidden crack	Check for cracks, replace if necessary	
Mismatch of components	Select all components according to system application and product specification	
	Use genuine Parker components	
Phantom leak, from assembly lubricant	Carefully identify proper source of leak	
	Don't over use lubricant	
Tube fractured behind the nut	Fatigue failure of tube under vibration	Review final tightening process, undertightening reduces vibration resistance
		Stress free installation
		Proper use of clamps
		Bulkhead connection and hose to isolate joints from vibration
		Make sure that operating conditions (pressure, corrosion, temperature, pressure peaks ...) do not exceed fitting performance
Crack	Insufficiently tightened, shallow bite	Tighten the nut according to correct number of turns
		Use correct spanners and spanner extensions especially for larger sizes and stainless steel fittings
		Mark nut and body to indicate correct assembly
		Use recommended lubrication
		Pre-assemble joints away from installation to ensure proper bite
		Check visible collar

DPR/PSR Problem	Probable cause	Suggested solution	
Crack	Severe working conditions	Make sure that operating conditions (pressure, corrosion, temperature, pressure peaks, ...) do not exceed fitting performance	
Tube blow out	Standpipe fitting, improper final assembly	Use swivel nut fitting	
	Cold welded threads on stainless steel fittings	Use "EODUR" stainless steel fittings from Parker (with silver plated nut threads) and always lubricate threads with EO Niromont fluid (not hydraulic oil)	
	Use of worn or unsuitable pre-assembly tools	Check tools regularly and replace worn tools	
		Keep tooling clean and oiled plus check cone regularly with "KONU" cone gauges every 50 assemblies	
		Tube not bottomed into fitting shoulder	Cut tube to correct length
			Observe min. straight length before tube bend
	Severe working conditions	Use hacksaw and guide not a plumbing – style tube cutter	
		Carefully deburr tube end – no heavy chamfers	
		Push tube firmly into cone	
	Ring installed in wrong direction	Check visible collar	
		Make sure that operating conditions (pressure, corrosion, temperature, pressure peaks, flow rate, ...) do not exceed fitting performance	
Check visible collar			
Steel ring used on stainless steel tube	Install ring in proper orientation		
	Use pre-assembled fitting or EO-2		
Stainless steel fitting not pre-assembled	Always check assembly before final installation		
	Use stainless steel bite rings for stainless steel tube, preassembly necessary		
Fitting body used as preassembly tool	Pre-assemble joint away from installation		
	Use specified preassembly tools/machines		
Short tube end fracture	Use specified preassembly tools, machine preset preferred		
	Fatigue failure	Use swivel nut adapter (GZ ...)	



EO-2 Problem	Probable cause	Suggested solution
Leak	Insufficiently tightened, shallow bite	Use of pre-assembly machines e. g. EO-KARRYMAT, EOMAT II, EOMAT III/A
		Insufficiently tightened
	Use correct spanners and spanner extensions especially for larger sizes and stainless steel fittings	
	Use recommended lubrication	
	Pre-assemble joints away from installation to ensure proper bite	
	Use original EO pre-assembly tools	
	Check closed gap	
Tube not bottomed into fitting shoulder	Cut tube to correct length	
	Observe min. straight length before tube bend	

Trouble shooting

EO-2 Problem	Probable cause	Suggested solution
Leak	Tube not bottomed into fitting shoulder	Use hacksaw and guide not a plumbing – style tube cutter
		Use EO-2 MOK for big sizes
		Carefully deburr tube end – no heavy chamfers
		Push tube firmly into cone
	Damaged fitting	Check for damage Handle all components carefully
	Damage to fitting cone	Make sure tube is bottomed at assembly
	Contamination between sealing surfaces	Keep all components clean
	Hidden crack	Check for cracks, replace if necessary
	Mismatch of components	Select all components according to system application and product specification Use genuine Parker components
	Phantom leak from assembly lubricant	Carefully identify proper source of leak Don't over use lubricant
Sealing ring (DOZ) missing	Use plugs for transport of preassembled tubes. Check assembly before final installation	
Tube fractured behind the nut	Fatigue failure of tube under vibration	Stress free installation
		Proper use of clamps
		Bulkhead connection and hose to isolate joints from vibration
Severe working conditions	Make sure that operating conditions (pressure, corrosion, temperature, pressure peaks ...) do not exceed fitting performance	
Crack	Insufficiently tightened	Use correct spanners and spanner extensions especially for larger sizes and stainless steel fittings
		Use recommended lubrication
		Pre-assemble joints away from installation to ensure proper bite
		Use original EO preassembly tools
		Check closed gap
Tube blow out	Cold welded threads on stainless steel fittings	Use "EODUR" stainless fittings from Parker (with silver plated nut threads) and always lubricate threads with EO Niromont fluid (not hydraulic oil)
		Tube not bottomed into fitting shoulder
	Tube not bottomed into fitting shoulder	Cut tube to correct length
		Observe min. straight length before tube bend
		Use hacksaw and guide not a plumbing – style tube cutter
		Carefully deburr tube end – no heavy chamfers
		Push tube firmly into cone
	Use EO-2 MOK for big sizes	
	Severe working conditions	Make sure that operating conditions (pressure, corrosion, temperature, pressure peaks, flow rate ...) do not exceed fitting performance
	Fitting undertightened	Tighten the nut until cap between retaining and sealing ring is closed
Use correct spanners and spanner extensions especially for larger sizes and stainless steel fittings		

EO-2 Problem	Probable cause	Suggested solution
Tube blow out	Fitting undertightened	Mark nut and body to indicate correct assembly
		Use recommended lubrication
		Pre-assemble joints away from installation to assure proper bite
Short tube end fracture	FM ... steel is used	Use exclusively FM stainless steel with stainless steel on stainless steel tube, for combination of steel fitting/ stainless steel tube use FM ... SSA nut
	Fatigue failure	Use swivel nut adapter (GZ ...)

EO2-FORM Problem	Probable cause	Suggested solution
Leak	Insufficiently tightened, shallow bite	Use correct spanners and spanner extensions especially for larger sizes and stainless steel fittings
	Damaged fitting	Check for damage
		Handle all components carefully
	Damage of fitting cone	Make sure tube is bottomed at assembly
	Contamination between sealing surfaces	Keep all components clean
	Hidden crack	Check for cracks, replace if necessary
	Mismatch of components	Select all components according to system application and product specification
		Use genuine Parker components
	Phantom leak from assembly lubricant	Carefully identify proper source of leak
		Don't over use lubricant
Sealing ring (DOZ) missing	Use plugs for transport of preassembled tubes. Check assembly before final installation	
Incorrect tube forming	Check assembly before installation	
	Use correct tool according to tube diameter, wall thickness and material	
	Regularly check tools for wear and damage	
	Replace damaged tooling	
	Use specified lubricant 1040 LUBSS on forming process	
Misalignment	Stress free installation. Flanged tube end needs contact to stud ends before final tightening. Check length and bends of tubing to ensure this	
Crack	Fatigue failure of tube under vibration	Stress free installation
		Proper use of clamps
		Bulkhead connection and hose to isolate joints from vibration
Severe working conditions	Make sure that operating conditions (pressure, corrosion, temperature, pressure peaks ...) do not exceed fitting performance	



Trouble shooting

O-Lok® Problem	Probable cause	Suggested solution
Leak	Damaged O-ring	Hold sealing surfaces together until nut is firmly tightened
	Missing O-ring	Use genuine Parker O-Lok® fittings with Captive O-ring groove (CORG)
	Extruded O-ring	Ensure proper alignment
		Tightened to proper torque
		Use genuine Parker O-Lok® fittings with Captive O-ring groove (CORG)
	Pinched O-ring due to air bleeding	Use bleed valves (PNLOBA/FNLBA) or test points EMA and hose for bleeding
	Phantom leak from assembly lubricant	Carefully identify proper source of leak
		Don't over use lubricant
	Uvertightening	Use correct spanners and spanner extensions especially for larger sizes and stainless steel fittings. Use recommended torque or FFFT method
Damaged fitting	Check for damage	
	Handle all components carefully	
Poor surface quality of flange	Spiral marks can be avoided by proper deburring of tubes, particular the tube I.D.	
	Clean tools, remove metal particles from pin	
Hidden crack	Check for cracks, replace if necessary	
Tube fractured behind the nut	Fatigue failure of tube under vibration	Stress free installation
		Proper use of clamps
		Bulkhead connection and hose to isolate joints from vibration
Severe working conditions	Make sure that operating conditions (pressure, corrosion, temperature, pressure peaks ...) do not exceed fitting performance	
Crack	Fatigue failure of tube under vibration	Stress free installation
		Proper use of clamps
		Bulkhead connection and hose to isolate joints from vibration
	Severe working conditions	Make sure that operating conditions (pressure, corrosion, temperature, pressure peaks ...) do not exceed fitting performance

Triple-Lok® Problem	Probable cause	Suggested solution
Leak	Damaged fitting	Check for damage
		Handle all components carefully
	Contamination between sealing surfaces	Keep all components clean
	Hidden crack	Check for cracks, replace if necessary
	Mismatch of components	Select all components according to system application and product specification
		Use genuine Parker components
	Phantom leak from assembly lubricant	Carefully identify proper source of leak
Don't over use lubricant		

Triple-Lok® Problem	Probable cause	Suggested solution
Leak	Undertightening	Use correct spanners and spanner extensions especially for larger sizes and stainless steel fittings. Use recommended torque or FFFT method
	Scratches in Tube ID and flare area	Use Parflange process to improve surface quality
Tube fractured behind the nut	Fatigue failure of tube under vibration	Stress free installation
		Proper use of clamps
		Bulkhead connection and hose to isolate joints from vibration
Crack	Fatigue failure of tube under vibration	Stress free installation
		Proper use of clamps
		Bulkhead connection and hose to isolate joints from vibration
	Severe working conditions	Make sure that operating conditions (pressure, corrosion, temperature, pressure peaks ...) do not exceed fitting performance



Weld nipples Problem	Probable cause	Suggested solution
Leak	Misalignment	Stress free installation
		Fix weld nipple to tube in application before finishing the welding
	Damaged O-ring	Inspect O-ring before final installation. Make sure that O-ring is not twisted at installation lubricate O-ring
	Missing O-ring	Assemble proper O-ring
	Extruded O-ring	Ensure proper alignment
	Pinched O-ring due to air bleeding	Use bleed valves (PNLOBA/FNLBA) or test points EMA and hose for bleeding
	Phantom leak from assembly lubricant	Carefully identify proper source of leak
		Don't over use lubricant
Undertightening	Use correct spanners and spanner extensions especially for larger sizes and stainless steel fittings	
Damaged fitting		Check for damage
		Handle all components carefully
Tube fractured behind the nut	Fatigue failure of tube under vibration	Stress free installation
		Proper use of clamps
		Bulkhead connection and hose to isolate joints from vibration
	Severe working conditions	Make sure that operating conditions (pressure, corrosion, temperature, pressure peaks ...) do not exceed fitting performance
Crack	Fatigue failure of tube under vibration	Stress free installation
		Proper use of clamps
		Bulkhead connection and hose to isolate joints from vibration
	Severe working conditions	Make sure that operating conditions (pressure, corrosion, temperature, pressure peaks ...) do not exceed fitting performance

Trouble shooting

Flanges connection Problem	Probable cause	Suggested solution
Leak	Misalignment	Stress free installation
	Damaged O-ring	Inspect O-ring before final installation. Make sure that O-ring is not twisted at installation lubricate O-ring
	Missing O-ring	Assemble proper O-ring
	Extruded O-ring	Ensure proper alignment Tightened bolts to recommended torque
	Pinched O-ring due to air bleeding	Use bleed valves (PNLOBA/FNLBA) or test points EMA and hose for bleeding
	Phantom leak from assembly lubricant	Carefully identify proper source of leak Don't over use lubricant
	Undertightening	Use correct spanners and spanner extensions especially for larger sizes and stainless steel fittings
	Unequal tightening	For flanges with more than 2 screws: see assembly instruction in what order the screws need to be tightened
	Damaged fitting	Check for damage Handle all components carefully
Tube fractured behind the nut	Fatigue failure of tube under vibration	Stress free installation
		Proper use of clamps Bulkhead connection and hose to isolate joints from vibration
	Severe working conditions	Make sure that operating conditions (pressure, corrosion, temperature, pressure peaks ...) do not exceed fitting performance
Crack	Fatigue failure of tube under vibration	Stress free installation
		Proper use of clamps Bulkhead connection and hose to isolate joints from vibration
		Severe working conditions

Leaks from ports Problem	Probable cause	Suggested solution
Leak	O-ring sealing is missing/damaged	Replace with new O-ring
	Fitting not tightened properly, Undertightening	Retighten to appropriate specification
	Undertightened at initial assembly	Use correct spanners and spanner extensions especially for larger sizes and stainless steel fittings Use recommended lubrication
	Adjustable stud not assembled properly	Repeat with appropriate assembly torque
	O-ring pinched	Proper assembly procedure
	Fitting vibrates loose	Redesign system Clamping/Check the assembly torque Stressed joints
	Threads damaged	Replace fitting
	Use of tapered threads (NPT/BSPT/+++)	Use fittings with soft sealing O-ring/ED sealing

Leak from port Problem	Probable cause	Suggested solution
Leak	Port stud end Form B	Sealing edge Form B is damaged replace fitting
	Sealing surface is damaged	Rework sealing surface
Fitting vibrates loose	Undertightened at initial assembly	Tighten the nut according to correct torque Use correct spanners and spanner extensions especially for larger sizes and stainless steel fittings
	Torsion forces on assembly	Use clamps or bulkhead fittings to isolate twisting hose Avoid stress at initial assembly
	Fractured stud	Severe overtightening Fatigue failure of tube under vibration Severe working conditions



Triple-Lok® 1025/1040/1015/1020		
Problem	Probable cause	Suggested solution
Tube slips in die during flanging or flaring	Tube undersized	Use tube within tolerance
	Die grip surface dirty	Clean with solvent
	Die grip surface worn	(do not use any wire brush) Replace Die
Flange/flare diameter too small	Tube slipped in die	See problem "Tube slips in die ..."
	Incorrect pin	Use correct pin for tube size
	Die needs adjustment/incorrect die.	Contact Parker Rep./Use correct die
	Tube was not inserted to tube stop	Insert tube to tube stop
Flange/flare diameter too large	Tube forced against tube stop	Do not force tube against tube stop
	Die needs adjustment/incorrect die	Contact Parker Rep./Use correct die
	Incorrect pin and/or tube wall	Use correct pin for tube size
Flange/flare out of round	Tube not cut squarely	Cut tube squarely, within $\pm 1^\circ$
	Tube not supported properly	Support tube in line with dies
	Obstruction in die holder	Clean and remove debris
	Tube wall thickness varies	Use good quality tube
	Incorrect pin and/or tube wall	Use correct pin for tube size
Cracked flange/flare	Poor tube quality	Use recommended quality tube
	Too hard tube	Use recommended quality tube
	Heavy chatter during deburring	Eliminate chatter in deburring
Scored, pitted flange/ flare surface	Improper/lack of lubrication on pin	Use recommended lubricant
	Tube not properly deburred	Deburr and remove filings
	Tube not properly cleaned	Clean to remove filings
	Pin not cleaned	Keep pin clean but lubricated
Tube slips in die during flanging or flaring	Tube undersized	Use tube within tolerance
	Die grip surface dirty	Clean with solvent
	Die grip surface worn	(do not use any wire brush) Replace Die

Trouble shooting

O-Lok® 1025/1040 Problem	Probable cause	Suggested solution
Flange/flare diameter too large	Tube forced against tube stop	Do not force tube against Tube stop
	Die needs adjustment/	Contact Parker
	Incorrect die	Use correct die
	Incorrect pin and/or tube wall	Use correct pin for tube size
	Sleeve not located properly in die	Locate sleeve in die cavity correctly
Flange/flare not round	Tube not cut squarely	Cut tube squarely, within $\pm 1^\circ$
	Tube not supported properly	Support tube in line with dies
	Obstruction in die holder	Clean and remove debris
	Tube wall thickness varies	Use good quality tube
	Incorrect pin and/or tube wall	Use correct pin for tube size
Cracked flange/flare	Poor tube quality	Use recommended quality tube
	Tube too hard	Use recommended quality tube
	Heavy chatter during deburring	Eliminate chatter in deburring
Scored, pitted flange/flare surface	Improper/lack of lubrication on pin	Use recommended lubricant
	Tube not properly deburred	Deburr tube and remove filings
	Tube not properly cleaned	Clean tube to remove filings
	Pin not cleaned	Keep pin clean and lubricated
Flange pin breaks during flanging	Incorrect pin and/or tube wall/ or wrong pin for tube material	Use correct pin for tube size/material















Assembly tooling











Assembly tooling

Index

<p>Manual assembly tools for EO/EO2</p>	 <p>VOMO p. H5</p> <p>KONU p. H6</p>	<p>Manual assembly devices</p>  <p>HVM-B p. H8</p>	 <p>EO-KARRYMAT p. H10</p>
<p>Assembly machines for EO/EO2, Triple-Lok®</p>	 <p>EOMAT II p. H12</p>	 <p>EOMAT III/A p. H16</p>	
<p>Forming machine for EO2-FORM</p>	 <p>EO2-FORM F2 p. H24</p>		
<p>Manual flaring tools for Triple-Lok®</p>	 <p>1004/210A p. H28</p>	 <p>Impact flarer p. H28</p>	 <p>1015 p. H28</p>
<p>Parflange®-Machines for O-Lok®/Triple-Lok®</p>	 <p>1025 p. H38</p>	 <p>1040 p. H38</p>	
<p>Lubricants</p>	 <p>NIROMONT p. H43</p>	 <p>LUBSS p. H43</p>	

Index

<p>Cutting, bending and deburring tools</p>	 <p>AV 6/42 p. H44</p>	 <p>BAV 6/12 p. H45</p>	 <p>IN-EX 226 p. H45</p>
<p>Tube bending tools</p>	 <p>BV 6/18 p. H46</p>	 <p>BV 20/25 p. H47</p>	
<p>Hand-tools</p>	 <p>Par-Lok wrench p. H48</p>	 <p>WKZ - Tool box p. H49</p>	
<p>O-Ring assembly tools for O-Lok®</p>	 <p>O-Lok® CORG p. H50</p>	 <p>O-Ring Pick p. H50</p>	
<p>Port manufacturing tools</p>	 <p>Counterbore p. H51</p>	 <p>Thread taps p. H51</p>	
<p>Thread identification</p>	 <p>Thread ID kit p. H53</p>	 <p>Portboard p. H53</p>	
<p>Training equipment/Books</p>	 <p>Training case p. H54</p>	 <p>Presentation case p. H55</p>	 <p>Pocket book p. H56</p>



Parker tube fabricating equipment

Equipment described in this section is designed to make strong, accurate tubing systems easier and more dependable. Every time you make up a tubing circuit, you want to be sure you get strong dependable joints, accurate kink-free bends and a neat system that will stand up to years of hard service. You want to fabricate the system with the least effort and risk of errors.

Parker tube fabricating equipment is designed to help you get all these benefits. Parker has been leading the way in use of tubing and in fittings design for over 60 years. All this experience has shown Parker engineers a host of ways to make tube fabricating equipment more efficient and trouble free. You'll find them all in the equipment featured here – from improvements that help you make accurate concentric flares, to bender designs that make kink-free bending easier. They'll all help you get better tubing systems with less work and less risk of mistakes in fabrication.

Nomenclature

Order assembly equipment by specification and order code as listed in this catalogue.

Most TFDE tube fabricating tools carry simple 3-, 4- or 6-digit part numbers. In some cases order codes for accessories are constructed from numbers which, where applicable, identify the size or sizes of tubing they are intended to handle. Size number may either precede or follow basic order code. In other cases (as for lubricants) simple identification by name is used.

Machine selection

Parker offers a variety of assembly devices and machines for different products and different applications.

Refer to overview in chapter E for machine recommendation.

Service

Assembly machines and standard tooling for TFDE connectors are available from stock for immediate service.

Both purchasing and leasing are possible depending on machine type and volume of business. For limited projects, assembly equipment can be provided on a rental basis via our certified distributor network.

Special "demo"-equipment is available for sales presentations and fairs.

Technical support

TFDE machine service procedures ensure that reliable machine function and fitting performance is achieved when using genuine Parker assembly equipment.

All machines come with detailed operating manuals. Parker distributors and sales representatives are trained to give

advice on operation and application. Experienced application engineers at TFDE are available when it comes to special application of TFDE assembly equipment.

In case of machine malfunction, spare machines can be provided on short notice so that production can continue. In the meantime, damaged machinery is checked and repaired at the TFDE machine repair facility. Well trained and experienced engineers take personal care that the machines return properly repaired and tested.



Experienced engineers support proper operation of TFDE assembly machinery

TFDE also offers a machine maintenance and calibration service. Standard spare parts like oil filters can be ordered from stock.

Repair procedure

Please contact your Parker Service Center for problem solving/repair. Your correspondent will organise the repair and arrange a spare machine if required. Please do not send in machines without notice to your sales correspondent. To assure optimum service, all machine shipments must include a documentation with information about: Machine type, serial number, purchase data, problem description, contact name, phone number and complete address for return.

Manual assembly tools for EO/EO-2

VOMO – Pre-assembly tools for EO/EO-2 tube connections

Simple but essential tool for the manual presetting of EO-fittings.

The use of a VOMO assures that the bite ring securely cuts into the tube without damage on the inner fitting cone.

Pre-assembly using VOMO or EOMAT must be done for all connections of:

- EO-2 with large tube dimensions (Tube OD 30 mm and above)
- EO-Progressive Stop Ring/Progressive Ring with stainless steel tube or standpipe fittings (E.g.: “BE”-type hose fitting).

For proper use, see EO assembly instructions. VOMO tools wear out and then may cause assembly failures. VOMO’s must be checked regularly with “KONU” cone gauges (max. after 50 assemblies) and replaced when damaged or worn out.

Specifications:

Material: hardened tool steel

Sizes: 4 LL – 12 LL,
6 L – 42 L,
6 S – 38 S

Pre-assembly of: EO-2 and Progressive Stop Ring PSR/EO progressive Stop Ring DPR

Features, advantages and benefits of pre-assembly tools:

1. **Marking notch** – A special notch engraves a circular mark onto the tube end to verify that it was properly bottomed at assembly. Failures caused by improper tube cutting or bottoming in VOMO can be recognised before final installation.



2. **Flexible** – A VOMO can be used anywhere to assure safe fitting assembly – even at assembly sites where EOMAT technology is not available.
3. **Safe** – Hazardous blowout of incorrect assembled standpipe hose fittings or stainless steel tube can be avoided by VOMO-assembly.
4. **Efficient** – There is no doubt that VOMO-presetting contributes to save time and effort in bite-type assembly. The little investment pays back immediately.
5. **Special** – VOMO tools are specifically designed and manufactured to match EO-fitting standards.

Series	Tube o.d. mm	Pre-assembly tools Order code	Cone gauges Order code
LL	4	VOMO04LLX	KONU04+06LLX
	6	VOMO06LLX	KONU06+08LLX
	8	VOMO08LLX	
	10	VOMO10LLX	KONU10+12LLX
	12	VOMO12LLX	
L	6	VOMO06LX	KONU06+08LX ¹⁾
	8	VOMO08LX	KONU10+12LX ¹⁾
	10	VOMO10LX	
	12	VOMO12LX	KONU15+18LX
	15	VOMO15LX	
	18	VOMO18LX	KONU22+28LX
	22	VOMO22LX	
	28	VOMO28LX	KONU35+42LX
	35	VOMO35LX	
	42	VOMO42LX	
S	6	VOMO06SX	KONU06+08LX ¹⁾
	8	VOMO08SX	KONU10+12LX ¹⁾
	10	VOMO10SX	
	12	VOMO12SX	KONU14+16SX
	14	VOMO14SX	
	16	VOMO16SX	KONU20+25SX
	20	VOMO20SX	
	25	VOMO25SX	KONU30+38SX
	30	VOMO30SX	
	38	VOMO38SX	

1) Cone gauges for tube o.d.6 to 12 mm are identical in series L and S.



Assembly tooling

KONU – Cone gauge for EO/EO-2 tube connections

Cone gauges are essential for monitoring wear on pre-assembly tools like VOMO, MOK or MOS.

KONU must be regularly used to prevent assembly failures caused by worn out or damaged tools (DIN 3859-2: max. each 50th assembly).

For proper use see EO assembly instructions.

Specifications:

Material: hardened tool steel

Sizes: 4 LL – 12 LL,
6 L – 42 L,
6 S – 38 S
(Sizes 6 L – 12 L
are identical to 6 S – 12 S)

Features, advantages and benefits of cone gauges:

- Special** – KONU are high precision gauges specifically designed and manufactured to match EO standards.
- Practical** – For easy handling and less inventory, each KONU gauge is suitable for two sizes.
- ISO 9001** – Simple but effective method to assure ISO 9001 specification for monitoring tools.
- Maintenance tool** – A leaking fitting can be easily checked and replaced if worn-out.



Series	Tube o.d. mm	Cone gauges Order code
LL	4	KONU04+05LLX
	6	KONU06+08LLX
	8	KONU06+08LLX
	10	KONU10+12LLX
L	12	KONU10+12LLX
	6	KONU06+08LX ¹⁾
	8	KONU06+08LX ¹⁾
	10	KONU10+12LX ¹⁾
	12	KONU10+12LX ¹⁾
	15	KONU15+18LX
	18	KONU15+18LX
	22	KONU22+28LX
S	28	KONU22+28LX
	35	KONU35+42LX
	42	KONU35+42LX
	6	KONU06+08LX ¹⁾
	8	KONU06+08LX ¹⁾
	10	KONU10+12LX ¹⁾
	12	KONU10+12LX ¹⁾
	14	KONU14+16SX
	16	KONU14+16SX
	20	KONU20+25SX
25	KONU20+25SX	
30	KONU30+38SX	
38	KONU30+38SX	

¹⁾ Cone gauges for tube o.d. 6 to 12 are identical in series L and S.

Checklist “depth measurement” for pre-assembly tooling (MOK and VOMO)

Type	T _{min}	T _{max}	Type	T _{min}	T _{max}
6-L	6.95	7.05	6-S	6.95	7.05
8-L	6.95	7.05	8-S	6.95	7.05
10-L	6.95	7.05	10-S	7.45	7.55
12-L	6.95	7.05	12-S	7.45	7.55
15-L	6.95	7.05	14-S	7.95	8.05
18-L	7.45	7.55	16-S	8.45	8.55
22-L	7.45	7.55	20-S	10.45	10.55
28-L	7.45	7.55	25-S	11.95	12.05
35-L	10.45	10.55	30-S	13.45	13.55
42-L	10.95	11.05	38-S	15.95	16.05

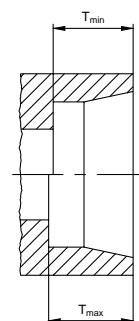

Manual assembly devices for EO/EO-2 tube connections

Machine selection guide

Manual assembly devices are available to reduce assembly time and effort. High assembly quality and consistency assures reliable fitting performance. EO assembly devices are manually operated and do not need any external power supply.



Due to the low weight, easy handling and simple but reliable design, the EO assembly devices are the ideal tool for tube preparation of small quantities.

For efficient mass production, manual devices are not suitable, therefore EOMAT machines are recommended.

Features, advantages and benefits

- 1. Flexible** – Manual assembly devices are portable and do not need any power supply. Therefore they are ideal for on-site tube assembly, repair and plant maintenance.
- 2. Economic** – Manual assembly devices close the gap in between manual fitting pre-assembly in a vice and the Eomat technology. The devices contribute to save time and effort in bite type assembly. The little investment pays back immediately.
- 3. Controlled assembly** – After pre-assembly, the tube joint can be easily inspected before final installation. Therefore, this mandatory step in fitting assembly is less likely to be forgotten.
- 4. Special** – Each device has been especially developed for the efficient use in a certain application. The HVM-B is a handy tool for the quick pre-assembly of EO Progressive rings onto soft steel tube. The EO-KARRYMAT is a real problem solver when it comes to on-site assembly of medium to large EO-Progressive rings and EO-2 fittings onto steel and stainless steel tube.

How to select the ideal assembly device for your application:

	HVM-B 	EO-KARRYMAT 
Assembly method EO-2: PSR/DPR/D: Triple-Lok®:	not suitable Stroke controlled not suitable	Pressure controlled Pressure controlled not suitable
Tube specification Material: Outside diameter/mm: Wall thickness:	Steel 4–15 mm no limitation	Steel, Stainless Steel 6–42 mm no limitation
Tool specification	Special assembly cones MOSI and plates HL	Standard assembly cones MOK and plates GHP
Operation drive	Lever with eccentric cam	Handpump
Process control	Assembly stroke determined by tool geometry	Pressure control according to selection chart
Preassembly is equal to EO-2: PSR: D/DPR:	– 1 turn 1 turn	Gap closed 1½ turn 1¼ turn
Performance Overall cycle time:	10 secs.	30–60 secs.
Application	Simple tool for quick pre-assembly of small dimension EO-Progressive rings onto steel tubes	Most efficient for one-site assembly of medium to large DPR- and EO-2 connections onto any suitable tube material



Assembly tooling

HVM-B Pre-assembly tool

This pre-installation tool is a simple tool for a quick and safe pre-assembly of EO-Progressive Stop Ring/Progressive ring. The tool is very handy and can be used at any site provided a vice is available. Suitable for LL, L and S series and tube sizes from 4 to 15 mm O.D.

Attention:

- ⚠ **Not suitable for EO-2 assembly.**
- ⚠ **Not suitable for stainless steel progressive ring assembly.**
- ⚠ **Final assembly of 1/2 turn in fitting body required.**

Specifications:

For pre-assembly of: EO Progressive Stop Ring/Progressive Ring

Pre-assembly equals: 1 turn of nut

For assembly check and fitting installation see assembly instructions chapter E.

Tube O.D.: 4 to 15 mm
 Series: LL, L and S
 Tube and fitting material: Steel
 Weight: approx. 7.0 kg (without tools)

Features, advantages and benefits of pre-assembly tool:

1. **Special** – HVM-B is designed and manufactured to match EO-DPR standards.
2. **Vice mounted** – For easy workshop use, the HVM-B can be clamped into any vice.
3. **Flexible** – A HVM-B can be used anywhere to assure safe fitting assembly – even at assembly sites where EOMAT technology is not available.
4. **Efficient** – There is no doubt that HVM-B-presetting contributes to save time and effort in bite-type assembly. The little investment pays back immediately.

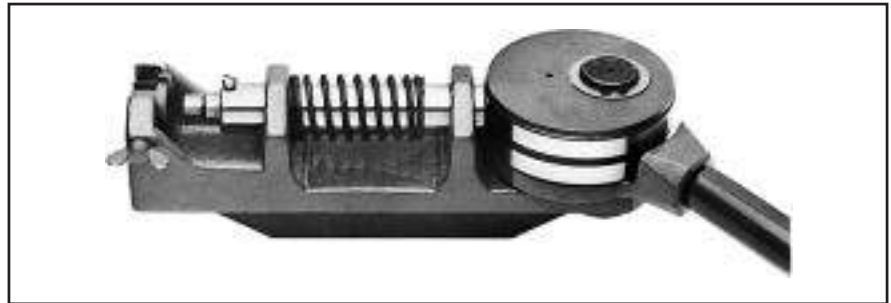

Type	Order code
HVM-B Pre-assembly tool device without tools	HVMBKPLX
Spare parts	
center bearing pin	HVMB02X
excenter roll	HVMB-03-1X

Series	Tube o.d. mm	Tube location plate Order code	Assembly cone Order code	Cone gauge Order code
LL	4	HL04X	MOSI04LLX	KONU04+05LLX
	5	HL05X	MOSI05LLX	
	6	HL06X	MOSI06LLX	KONU06+08LLX
	8	HL08X	MOSI08LLX	
	10	HL10X	MOSI10LLX	KONU10+12LLX
	12	HL12X	MOSI12LLX	
L	6	HL06X	MOSI06LX	KONU06+08L/X ¹⁾
	8	HL08X	MOSI08LX	
	10	HL10X	MOSI10LX	KONU10+12L/X ¹⁾
	12	HL12X	MOSI12LX	
	15	HL15X	MOSI15LX	KONU15+18L/X
S	6	HL06X	MOSI06SX	KONU06+08L/X ¹⁾
	8	HL08X	MOSI08SX	
	10	HL10X	MOSI10SX	KONU10+12L/X ¹⁾
	12	HL12X	MOSI12SX	
	14	HL14X	MOSI14SX	KONU14+16SX

1) Cone gauges for tube o.d. 6 to 12 are identical in series L and S.

HVM-B Pre-assembly tool

1



2



3



4



5



How to use

- Clamp HVM-B into vice.
- Select required assembly cone (MOS-I) and insert.
- The assembly cones are marked with tube O.D. and series (e.g. 10-L).

- Insert the tube location plate – HL – of corresponding size and fasten with screw.
- The tube location plates are marked with tube O.D. (e.g. "10").

- Slip nut "M" and Progressive Stop Ring PSR/ Progressive ring "DPR" (or cutting ring "D") over tube end and insert into pre-assembly tool.
- Nut position must be in front of tube location plate – HL – !

- Hold tube against stop in the assembly cone.

- Pull lever to turn the eccentric cam (Pre-assembly).

Attention

⚠ For assembly check and final assembly see PSR/DPR instructions.

Attention:

⚠ At final assembly nut must be tightened by 1/2 turn.

H

EO-KARRYMAT portable pre-assembly device for EO tube connections



Type	Order code
EO-KARRYMAT assembly device complete device including handpump and carrying case, including operation manual. Tools (assembly cone MOK and baching plate GHP) must be ordered separately.	EO-KARRYMAT
Promotion leaflet UK/DE	4044-DE/UK
Separate operating manual UK/DE/FR/IT	4044-T
Spare parts	
Handpump	82C-2HP
Pressure gauge	EO-KARRYMAT/MANO
Pressure chart sticker	EO-KARRYMAT/CHART
Cover hinge	EO-KARRYMAT/HINGE

The EO-KARRYMAT is a dependable device for safe and efficient bite-type presetting. It allows pre-assembly of even large dimension steel and stainless steel tube at assembly sites where EOMAT technology is not available. The EO-KARRYMAT consists of a hydraulic drive and a handpump. The hydraulic assembly pressure can be read on a gauge. The EO-KARRYMAT comes as one unit with all components firmly attached to a practical carrying frame.

Specifications:

For pre-assembly of: EO PSR/DPR and EO-2

Pre-assembly equals:
EO Progressive Stop
Ring (PSR): 1½ turn of nut
EO Progressive ring (DPR): 1¼ turn of nut
EO-2 "Gap closed"

For assembly check and fitting installation see assembly instructions chapter E.

Tube O.D.: 6 to 42 mm
Series: L and S
Tube and fitting material: Steel and stainless steel
Weight: approx. 28 kg
Oil: HLP23-1.22 (filled before delivery)

Features, advantages and benefits of EO-KARRYMAT:

1. **Ideal** – With some 28 kg, the EO-KARRYMAT is portable and does not need any power supply. Therefore

the EO-KARRYMAT is the ideal tool for on-site tube assembly, repair and plant maintenance.

2. **Economic** – The EO-KARRYMAT closes the gap in between manual fitting pre-assembly in a vice and the EOMAT technology. EO-KARRYMAT assembly is far less hard work as manual assembly but it achieves the dependent assembly result of the EOMAT assembly machine.

3. **"Must" for stainless steel** – As direct assembly of stainless steel tubes in bite type fittings results in failure, a special pre-assembly process is mandatory according to ISO 8483 / DIN 3859 and all manufacturers instructions. The EO-KARRYMAT fulfils this requirement.

4. **Dependent** – The use of the EO-KARRYMAT is far less demanding than manual fitting assembly using wrenches. It helps to prevent failures caused by insufficient fitting assembly which is most critical on large dimension steel and stainless steel tube.

5. **Controlled assembly** – After pre-assembly, the tube joint can be easily inspected before final assembly. Therefore, this mandatory step in fitting assembly is less likely to be forgotten.

6. **Special** – The EO-KARRYMAT has been especially developed for the efficient on-site assembly of EO Progressive ring and EO-2 fittings. The tools are designed according to a new EO-patent which allows safe as-

sembly of even large dimension steel and stainless steel tubes without excessive hard work.

The applications:

- Repair workshops
- Mobile repair service
- Plant maintenance in process engineering, paper production, power plants, offshore exploration, industrial production
- On-site assembly of tubing systems

Tube OD ∅ [mm]	EO-2 P [bar]	PSR P [bar]	DPR P [bar]
6	60	40	40
8	70	50	50
10	80	60	60
12	90	70	70
14	110	85	80
15	110	85	80
16	120	95	90
18	120	110	100
20	170	140	120
22	140	130	130
25	230	170	150
28	170	150	140
30	310	220	200
35	260	190	180
38	350	290	240
42	310	240	220

Installation	min. 1/6 max. 1/4	30°	1/4 turns
	min 60° -max 90°	~30°	~90°

Assembly machines for EO/EO-2 and Triple-Lok®

Machine selection guide

EOMAT assembly is much more cost efficient than manual assembly of EO-fittings. Assembly time and effort are greatly reduced. Proper and consistent pre-assembly support safe and leakfree fitting performance.

EOMAT machines are specifically designed to match EO-2, EO PSR/DPR rings and Triple Lok® standards. Assembly is achieved with high precision and repeatability.



EOMAT machines are available in several versions to serve individual applications. All machines are designed for reliable workshop use even under severe construction site working conditions. Tool handling and machine operation are simple.

How to select the ideal EOMAT machine for your application:

Features, advantage and benefits:

- 1. Universal** – Assembly of EO-2, EO PSR/DPR rings and 37° flaring for Triple-Lok® can be done with just 1 machine.
- 2. Efficient** – With a cycle time of some 15 seconds the EOMAT machine greatly saves assembly time and effort. The investment pays back soon.
- 3. Safe** – Proper pre-assembly greatly reduces the danger of leaking fittings or even hazardous tube blow out.
- 4. Strong** – Even 37° flaring of large size stainless steel tube is done within few seconds.
- 5. Flexible** – All tube dimensions from 6 to 42 mm can be machined. All common tube materials are covered, even plastic tube (EO-2 and PSR/DPR only).
- 6. Marking notch** – A special notch engraves a circular mark onto the tube end to verify that it was properly bottomed at assembly. Failures caused by improper tube cutting or bottoming in VOMO can be recognised before final installation.
- 7. Reliable** – For more than 20 years, hundreds of EOMAT machines are operated under heavy duty workshop conditions.



	EOMAT II		EOMAT III	
				
Assembly method: EO-2 D/PSR/DPR Triple-Lok®	Pressure controlled Pressure controlled Conventional 37° flaring		Pressure controlled Stroke controlled Conventional 37° flaring	
Tube specification: Material	Steel, Stainless Steel		Steel, Stainless Steel, Aluminium, Copper, Monel or CuNiFe, plastic tube such as nylon polyurethane, PVC or teflon (EO-2/DPR only)	
Outside diameter/mm	6–42 mm		4–42 mm	
Wall thickness: EO-2/PSR/DPR Triple Lok®	No limitation 6×1 to 38×4 or 42×3 mm (Tube O.D. x wall thickness)		No limitation 6×1 to 38×4 or 42×3 mm (Tube O.D. x wall thickness)	
Operation: Setting	Manual pressure adjustment according to selection chart Depending on: Assembly type; Tube dimension; Tube material		Menu selection of assembly type and tube dimension Automatic adjustment and control of process parameter	
Process control	Pressure gauge		Microprocessor Warning message for most typical assembly failures Yes, 26 memory locations Display warning when too low Display warning when too high Accessory	
Memory function	No			
Oil level control	Visual control			
Oil temperature control	No			
Foot operating switch	Not available			
Performance	3 Phase/400 V (380 V)		3 Phase/400 V (380 V)	
Overall cycle time (sec.):	1 Phase/230 V (220 V)		1 Phase/230 V (220 V)	
EO-2 presetting	12	15	10	13
PSR/DPR presetting	15	18	12	15
37° flaring	15	18	12	15
Continuous operating:	80 %	80 %	100 %	100 %
Weight	approx. 62 kg	approx. 60 kg	approx. 100 kg	approx. 98 kg
Application	Simple workshop tool for use on construction site	Only at assembly sites where 3 phase power supply is not available	Efficient production machine for low-cost and high quality assembly	Only at assembly sites where 3 phase power supply is not available

EOMAT II assembly and flaring machine

General

The EOMAT II is an electro-hydraulic machine for the assembly of:

EO-2 EO PSR/DPR and Triple-Lok® 37° flared tube fittings.

Compared to manual assembly it greatly reduces assembly time, effort and cost and also guarantees leakfree performance of constant high-quality fitting assemblies.

Common tube materials such as steel (ST 37.4 BK, ST 52.4 BK), stainless steel (1.4571/1.4541/316Ti or similar) and copper can be pre-assembled.

The tool range covers all metric tube sizes from 4 to 42 mm outer diameter. The required operating pressure is variable and set at the pressure gauge. The unit may therefore be used for a variety of different applications. The standard version is for 380 V supply, a 220 V version is also available on request. The tooling for either EO-2/PSR/DPR pre-assembly or tube flaring may be manually replaced, without the use of tools.

Technical data

Oil:
Esso Nuto H 32 or equal, 3.3L
(Reference oil change, see label on unit)
Operating pressure:
Variable from 15 to 200 bar
Dimensions:
Width 540 mm, height 245 mm, depth 420 mm

400 (380) V version

Hydraulic pump:
1.8 kW – 4.3 l/min
Feedrate: 8.3 mm/sec.
Electrical connection:
380 V/ 3~ / 50 Hz / 4.3 A
Connection cable:
5 m – CEE 16 A
Weight: 62 kg

230 (220) V version

Hydraulic pump:
1.3 kW – 2.5 l/min
Feedrate: 4.8 mm/sec.
Electrical connection:
230 (220) V/ 1~ / 50 Hz / 8.3 A
Connection cable:
5 m – Earth plug
Weight: 60 kg

We reserve the right to make modifications in the course of further technical development.

Features, advantages and benefits:

- Universal** – Assembly of EO-2, EO-PSR/DPR and 37° flaring for Triple-Lok® can be done with just 1 machine.
- Efficient** – With a cycle time of some 15 seconds the EOMAT II greatly saves assembly time and effort. The investment pays back soon.
- Safe** – Proper pre-assembly greatly reduces the danger of leaking fittings or even hazardous tube blow out.
- Strong** – Even 37° flaring of large size stainless steel tube is done within few seconds.
- Flexible** – All tube dimensions from 4 to 42 mm can be pre-assembled. All common tube materials are covered.
- Workshop tool** – With a 80 kg, the EOMAT II can be brought to an assembly site.
- Marking notch** – All VOMO tools feature a special notch in the bottom surface which is designed to engrave a circular groove into the tube-end at assembly. A missing of this mark indicates that the tube-end has not been properly bottomed at assembly.
- Reliable** – For more than 20 years, hundreds of machines are operated under heavy duty workshop conditions.

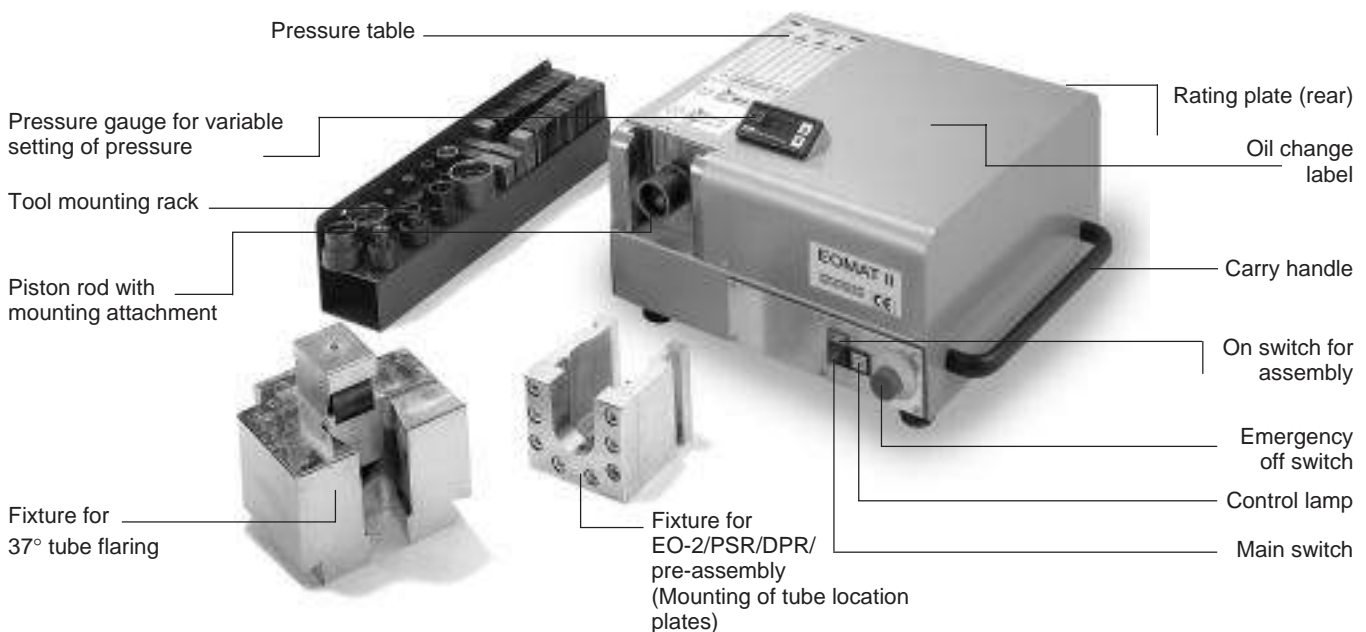

EOMAT II assembly and flaring machine

Basic operation for EO-2

Functional nuts

See EO-2 instructions for fitting assembly

1. Adjust EO-2 pressure according to chart (A)
2. Insert the pre-assembly fixture in the tool mounting weight approx. 5.5 kg).
3. Select the assembly cone (MOK) and backing plate (GHP) in accordance with the tube size and type.
4. Place and lock the assembly cone in the tool holder. Place the backing plate in the slot in the fixture.
5. Slide the EO-2 functional nut onto the tube, which has been cut off square and deburred.
6. Place the tube with the EO-2 functional nut in the pre-assembly fixture between backing plate and assembly cone.
7. Press the tube against the stop in the assembly cone. Hold the tube in this position. Press and hold the start button until the pre-assembly process is complete.
8. Take the assembled tube connection out of the location plate. See EO-2 assembly instruction (chapter E) for assembly check and installation instructions.
9. Check assembly result before final installation.



Basic operation for EO PSR/DPR ferrules

See PSR/DPR instructions for fitting assembly

1. Adjust PSR/DPR pressure according to chart (A)
2. Insert the pre-assembly fixture in the tool mounting (weight approx. 5.5 kg).
3. Select the assembly cone (MOK) and backing plate (GHP) in accordance with the tube size and type. Check the assembly cone using a cone gauge.
4. Place the assembly cone in the tool holder. Place the backing plate in the slot in the fixture.
5. Oil the ring, nut and assembly cone.
6. Slide the nut and ring onto the tube, which has been cut off square and deburred.
7. Place the tube with nut and progressive ring or cutting ring in the pre-assembly fixture between backing plate and assembly cone.
8. Press the tube against the stop in the assembly cone. Hold the tube in this position. Press and hold the start button until the pre-assembly process is completed.
9. Take the pre-assembled tube out of the backing plate. See EO PSR/DPR assembly instruction (chapter E) for assembly check and installation instructions.
10. Check assembly result before final installation.

Basic operation for 37° tube flaring

See Triple-Lok® instructions for fitting assembly

1. Adjust Triple-Lok® pressure according to chart (A)
2. Insert the tube flaring fixture in the toolmounting (weight approx. 19.5 kg).
3. Lubricate the flaring pin.
4. Insert the flaring die set corresponding to the tube size.
5. Push the nut and support sleeve onto the tube.
6. Push the tube through the flaring die hole to the stop plate. To prevent misalignment, longer tubes are to be supported during the flaring process.
7. Press the start button (or right-hand foot switch) and hold until the display reads "RELEASE START BUTTON". The flaring procedure is completed.
8. Lift the tube with the flaring die upwards out of the fixture.
9. To release the tube, place the flaring die set in the opening provided in the fixture and tilt the tube to one side.
10. Check assembly result before final installation.



Important!

Only proceed with pre-assembly when a tube with nut and cutting ring has been placed in the fixture (failure to observe this can result in damage to the tools). Longer tubes are to be suitably supported during pre-assembly. The assembly cones are to be regularly checked for correct dimensions using the cone gauge and should be replaced when necessary.

Caution: do not reach into the working area of the pre-assembly fixture while it is operating!











Important!

Do not drive the flaring pin into the flaring die without a tube in position. The roughened surface of the flaring die must be absolutely free of oil and grease to prevent the tube from slipping.

Caution: do not reach into the working area of the flaring fixture while it is operating!

EOMAT II assembly and flaring machine

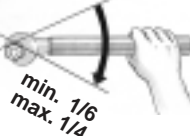
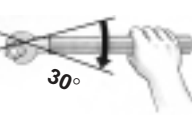
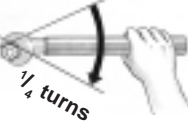
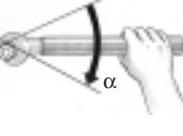
Pressure setting chart A

		<h1>EOMAT II</h1> 				
 Tube-OD Ø (mm)	 EO-2 P (bar)	 PSR P (bar)	 DPR P (bar)	 Triple-Lok® P (bar)		
6	30	25	25	20		
8	35	30	30	20		
10	45	35	35	35		
12	50	40	40	35		
14	60	50	45	45		
15	60	50	45	60		
16	70	55	55	60		
18	70	65	60	70		
20	100	80	70	95		
22	80	75	75	95		
25	130	100	90	105		
28	100	90	85	125		
30	180	125	115	135		
35	150	110	105	155		
38	200	170	140	165		
42	180	140	130	185		
 Installation	 min. 1/6 max. 1/4 min 60° – max 90°	 30° ~ 30°	 1/4 turns ~ 90°	 α min 60° – max 90°		
	Steel (ST 37.4 BK, ST 52.4 BK, . . .) Stainless Steel (ST 1.4571, 1.4541, 1.4301, 316 Ti, . . .)					

The given values are a guide. The results of pre-assembly and/or tube flaring are therefore always to be checked. For detailed instructions on tube preparation, tool selection, assembly check and final installation see chapter E.

EOMAT II assembly and flaring machine

Ordering

Type	Order code
EOMAT II Basic machine Ready to use, including operation manual Filled with hydraulic oil Without EO assembly fixture/Flaring fixture Without tools for EO-assembly/37° flaring Basic machine 400 V, 3 Phase, 50 Hz Basic machine 230 V, 1 Phase, 50 Hz	EOMATII380VX EOMATII220VX
Fixture for PSR/DPR/EO-2 assembly	EOMATSCHNEIDRX
37° Flaring fixture for Triple-Lok®	EOMATBOERDELBX
EOMAT II promotion leaflet UK	4042/UK
EOMAT II promotion leaflet DE	4042/DE
EOMAT II operating manual UK/DE/FR/IT	4042-OM/UK/DE/FR/IT

Assembly fixtures, tools, cone gauges, and lubricant must be ordered separately

Assembly tools for PSR/DPR/EO2 see page H5.

37° flaring tools for Triple-Lok® see page H28.

Spare parts

Type	Order code
Fixing clip for MOK	EOMAT/CLIP
37° flaring pin	EOMAT/FLAREPIN
O-ring for flaring pin	EOMAT/FLAREORING
Tube stop assembly for flaring block	EOMAT/FLAREHOUSING
Breath air filter for oil tank	EOMATII/AIRFILTER
Pressure chart sticker	EOMATII/CHART
Digital pressure adjustment display	SCE-025-01
Pressure switch for digital display	SCP-250-12-06
Pressure adjustment panel complete pressure switch and gauge for old version EOMATII	EOMATII/SWITCH-MECH

EOMAT III assembly and flaring machine with electronic control

General

The EOMAT III/A is an “electronically” controlled hydraulic drive unit for the assembly of:

**EO-2
EO PSR/DPR
Triple-Lok® 37° flared tube fittings.**

Compared to manual assembly it greatly reduces assembly time, effort and cost and also guarantees leakfree performance of constant high-quality fitting assemblies.

Common tube materials such as steel, (ST 37.4 BK, ST 52.4 BK) stainless steel (1.4571/ 1.4541/ 316Ti), aluminum, copper and even plastic (EO-2/PSR/DPR only) can be machined. The tool range covers all metric tube sizes from 4 to 42 mm outer diameter.

The required operating pressure depends on the assembly type and the tube dimensions, and it is automatically selected by a microprocessor. A multifunction display provides information about the current

operating data. Frequently used assembly data or special applications can be memorized; 26 memory locations are available for this purpose. These features allow for individual use of the unit. The standard version is for 380 V power supply; other voltage types and frequencies are available at extra charge.

The tools are the same as those of the EOMAT II and III versions and the fixtures for either the pre-assembly of cutting rings or for flaring tubes may be changed manually without using tools.

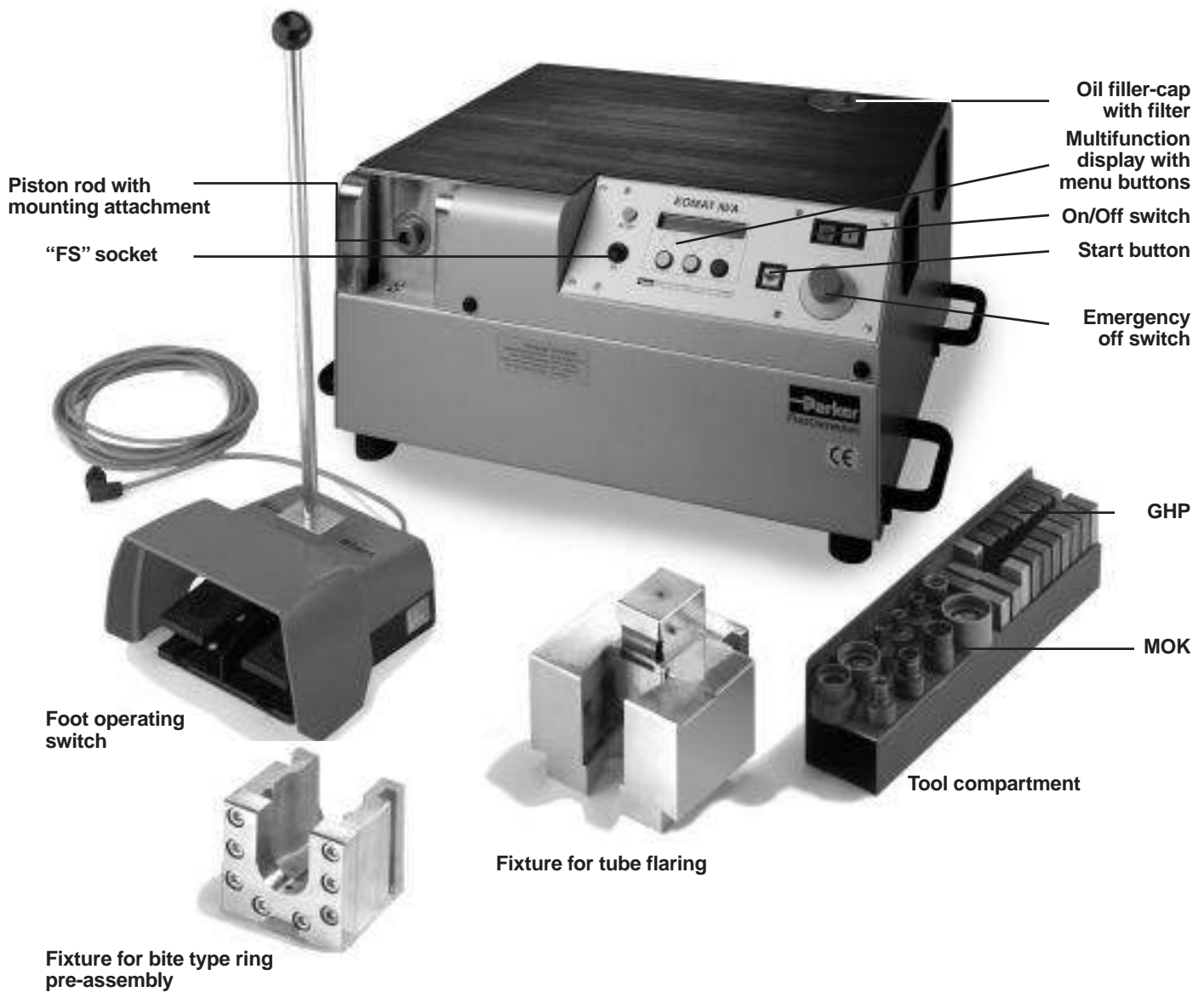

EOMAT III assembly and flaring machine with electronic control

Features, advantages and benefits of EOMAT III/A:

1. **Universal** – Assembly of EO-2, EO PSR/DPR and 37° flaring for Triple-Lok® can be done with just 1 machine.
2. **Efficient** – With a cycle time of some 10 seconds the EOMAT III/A greatly saves assembly time and effort. The investment pays back soon.
3. **Industrial production** – sufficient hydraulic oil volume and intelligent energy management allow continuous 24-hour operation without overheating. The drive unit is designed to last millions of cycles.
4. **Menu selection** – Operation is as easy as selecting the intended assembly process (EO-2/PSR/DPR/ 37° flare) and tube dimension. No pressure charts are necessary.
5. **Bite control** – In PSR and DPR-mode, the axial movement of the Progressive ring is controlled with an accuracy of 0.01 mm (0.0004 inch). This assures reliable leakfree fitting performance independent of lubrication or dimensional and hardness tolerances.
6. **Error messages** – All process parameter are controlled by the built-in microprocessor. Clear messages for typical failures are shown on the multifunction display.
7. **Safe** – Proper pre-assembly greatly reduces the danger of leaking fittings or even hazardous tube blow out.
8. **Strong** – Even 37° flaring of large size stainless steel tube is done within few seconds.
9. **Flexible** – All tube dimensions from 4 to 42 mm can be machined. All common tube materials are covered, even plastic tube (EO-2/PSR/DPR only).

10. **Marking notch** – All VOMO tools feature a special notch in the bottom surface which is designed to engrave a circular groove into the tube-end at assembly. A missing of this mark indicates that the tube-end has not been properly bottomed at assembly.
11. **No tool wear** – When the machine is only used for pre-assembly of EO-2 fittings, the VOMO tools do not wear. This prevents fitting failures caused by worn-out pre-assembly tools.
12. **Three languages display** – English/German/French can be easily selected for the display.
13. **Memory locations** – 26 memory locations are available to store regularly used specific assembly data.
14. **Foot switch** – For easy handling of long tubes and time efficient series production a foot switch is available.
15. **Machine monitoring** – A warning will be shown on the display when hydraulic oil level is low or oil temperature is high to avoid machine damage.

Technical specifications

Oil

Esso Nuto H 32 or equivalent, capacity 15 l (oil change once per year or every 2000 hours. Oil drain screw on the underside of the unit).

Working pressure:

Electronically adjusted from 12 to 200 bar.

Dimensions:

Width 690 mm, height 530 mm, depth 320 mm.

Hydraulic pump:

1.1 kW – 5.4 l/min.

Feed speed:

19 mm/sec, working stroke 8.7 mm/sec, return speed 13.3 mm/sec.

Electrical connection:

400 (380) V/3 Phase /50 Hz /2.8 A (standard). Other specifications on request.

Power cable:

5 m – CEE 16 A, with phase inverter.

Weight: 100 kg.

Technical specifications of the electronic control

Display:

LCD display, 2 Lines with 24 characters each. Character height 5.5 mm.

“MENU” buttons:

Three buttons for entering the menu. The button functions appear in the lower line of the LCD display.

“FS” socket:

For connecting the foot operating switch, plug connection: DIN 41524, 3-pole.

Ambient conditions:

Ambient temperature: 0 ... +50°C.
Storage temperature: –25 ... +60°C.

General:

Lithium battery for data memory.
Service life min. 5 years.

Initial operation

Phase polarity

Switch on the unit. Correct phase-polarity is checked by a trial run without tool and without fixtures. Press and hold down the start button (lit up). If the start button is not lit up, keep pressing the green menu button until the start button lights up. When phase-polarity is correct, the piston moves forward to the stop and then returns. The display shows the command „RELEASE START BUTTON“. When phase-polarity is incorrect, the piston does not move. In this case, switch off the unit and switch over the phase inverter in the plug, using a screw-driver.



EOMAT III assembly and flaring machine with electronic control

Basic operation for EO-2 functional nuts

See EO-2 instructions for fitting assembly

1. Pressure is automatically adjusted by the menu selection button (see paragraph "operating the multi-function display").
2. Insert the pre-assembly fixture in the tool mounting weight approx. 5.5 kg).
3. Select the assembly cone (MOK) and backing plate (GHP) in accordance with the tube size and type.
4. Place and lock the assembly cone in the tool holder. Place the backing plate in the slot in the fixture.
5. Slide the EO-2 functional nut onto the tube, which has been cut off square and deburred.
6. Place the tube with the EO-2 functional nut in the pre-assembly fixture between backing plate and assembly cone.
7. Press the tube against the stop in the assembly cone. Hold the tube in this position. Press and hold the start button (or right-hand foot switch) until the display gives the command "RELEASE START BUTTON". The pre-assembly process is complete.
8. Take the assembled tube connection out of the location plate. Loosen nut and check that the gap between the sealing ring and retaining ring is closed.
9. Check assembly before final installation.

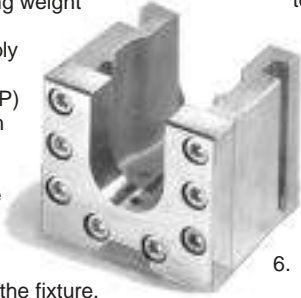

Basic operation for EO PSR/DPR rings

See PSR/DPR instructions for fitting assembly

1. Pressure is automatically adjusted by the menu selection button (see paragraph "operating the multi-function display").
2. Insert the pre-assembly fixture in the tool mounting (weight approx. 5.5 kg).
3. Select the assembly cone (MOK) and backing plate (GHP) in accordance with the tube size and type. Check the assembly cone using a cone gauge.
4. Place the assembly cone in the tool holder. Place the backing plate in the slot in the fixture.
5. Oil the ring, nut and assembly cone.
6. Slide the nut and ring onto the tube, which has been cut off square and deburred.
7. Place the tube with nut and ring or cutting ring in the pre-assembly fixture between backing plate and assembly cone.
8. Press the tube against the stop in the assembly cone. Hold the tube in this position. Press and hold the start button (or right-hand foot switch) until the display gives the command "RELEASE START BUTTON". The pre-assembly process is completed.
9. Take the pre-assembled tube out of the backing plate. The progressive ring or cutting ring has cut into the tube leaving a visible raised collar (check!).
10. Check assembly before final installation.

Basic operation for 37° tube flaring

See Triple-Lok® instructions for fitting assembly

1. Pressure is automatically adjusted by the menu selection button (see paragraph "operating the multi-function display").
2. Insert the tube flaring fixture in the tool mounting (weight approx. 19.5 kg).
3. Lubricate the flaring pin.
4. Insert the flaring die set corresponding to the tube size.
5. Push the nut and support sleeve onto the tube.
6. Push the tube through the flaring die hole to the stop plate. To prevent misalignment, longer tubes are to be supported during the flaring process.
7. Press the start button (or right-hand foot switch) and hold until the display reads "RELEASE START BUTTON". The flaring procedure is completed.
8. Lift the tube with the flaring die upwards out of the fixture.
9. To release the tube, place the flaring die set in the opening provided in the fixture and tilt the tube to one side.
10. Check assembly before final installation.



Important!

Only proceed with pre-assembly when a tube with nut and cutting ring has been placed in the fixture (failure to observe this can result in damage to the tools). Longer tubes are to be suitably supported during pre-assembly. The assembly cones are to be regularly checked for correct dimensions using the cone gauge and should be replaced when necessary.

Caution: do not reach into the working area of the pre-assembly fixture while it is operating!

Important!

Do not drive the flaring pin into the flaring die without a tube in position. The roughened surface of the flaring die must be absolutely free of oil and grease to prevent the tube from slipping.

Caution: do not reach into the working area of the flaring fixture while it is operating!

EOMAT III assembly and flaring machine with electronic control

Operation

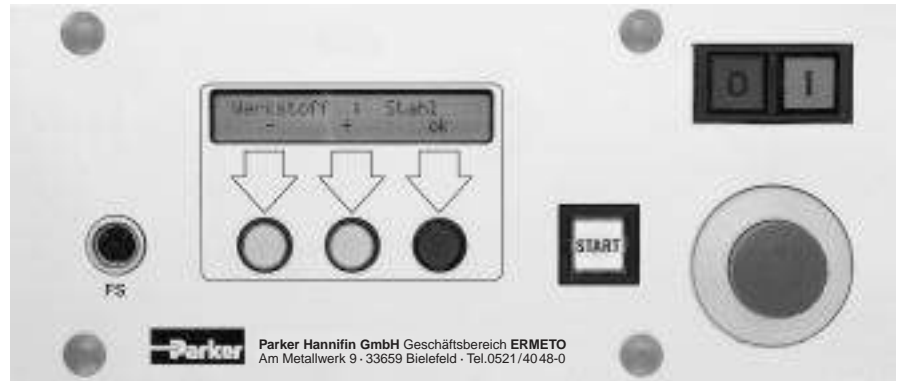

Choice of language (German/English/French)

1. To change the language, switch off the unit.
2. Switch the unit on again, holding down the green menu button.
3. The following image appears on the display after a few seconds:

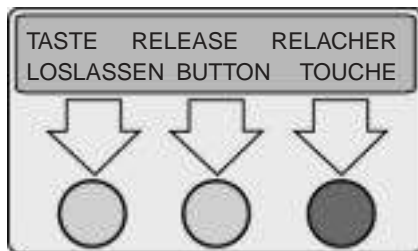

4. After releasing the green menu button, the languages are indicated:

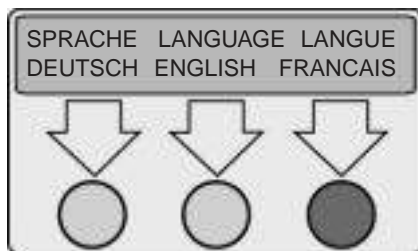

5. For German, press the left-hand yellow button; for English, press the right-hand yellow button; for French press the green button. All further information appears in the selected language, even after the unit has been switched off.

Entering a password

1. To change the password, switch off the unit.
2. Switch the unit on again, holding down the left-hand yellow menu button.
3. The following image appears on the display after a few seconds:

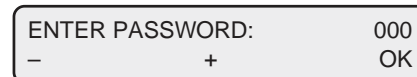

4. Using a yellow button (+ or -), enter the 1st number (flashes). Acknowledge with the green button. Enter the 2nd and the 3rd number in the same way. The following image appears on the display:

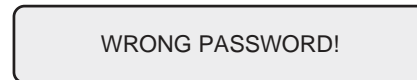

- 5a. This image disappears after a few seconds and the image of paragraph 3 appears.
- 5b. or the following image appears on the display:



- With the left-hand yellow button "CHANGE", a new password can be entered with the same procedure as under paragraph 4. With the right-hand yellow button "ON" the password protection will be switched on. Whenever one of the three menu buttons is pressed (i.e. the assembly parameters are to be modified), the password must be entered. With the green button "OFF" the password protection is switched off. All assembly parameters can be altered now without entering the password.
6. The password is preset as "000" in the factory.
 7. If a wrong password has been entered try again. This menu item can only be exited by switching off the unit.

Menu selection for standard range for steel and stainless steel

All settings are permanently programmed. Only assembly type, material and tube dimensions must be entered.

Example:

Pre-assembly with progressive ring, steel material, tube dimension 16 × 2 mm

1. The display shows the data of the last setting (random example):

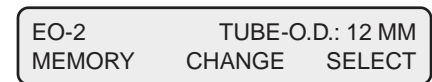

2. Press the green "SELECT" button. The start button is now not operating.

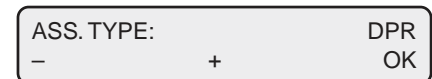

3. Using a yellow button (+ or -), select the assembly type until "DPR" appears. Acknowledge with the green "OK" button:

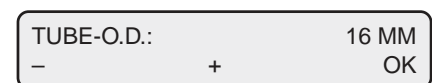

4. Using a yellow button (+ or -), select the tube outside diameter. Acknowledge with the green "OK" button. All required data have now been entered and the display shows the following:

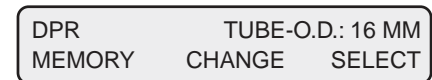

5. The start button is now ready (lights up). The assembly procedure can now begin as described in machine operation manual or assembly instructions chapter E.

EOMAT III assembly and flaring machine with electronic control

Operation

Programming memory locations for special applications

For special applications, individual assembly pressures and retention times can be entered and memorised. These are normally not available and can only be determined by trial assemblies. If necessary, please consult our technical service team. 26 memory locations are available, identified by the letters A to Z.

Example:

Enter and memorise: preassembly of progressive ring, tube o.d. 16 mm.

1. Select assembly type and tube o.d. as in the standard range:

DPR	TUBE O.D.: 16 MM
MEMORY	CHANGE SELECT

2. Press the right-hand yellow "CHANGE" button. The start button is now not operating.

ASS. PRESSURE:	36 BAR
-	+ OK

3. The assembly pressure for a special tube (19–200 bar) can now be individual entered using a yellow button (+ or –). Acknowledge with the green "OK" button.

RETENTION TIME:	1.0 SEC
-	+ OK

4. Using a yellow button (+ or –), adjust the retention time (0 to 9 sec). One second is normally sufficient. Acknowledge with the green "OK" button. The display now always shows the memory location "A".

A:	35 BAR	0.5 SEC
-	+ OK	

5. Using a yellow button (+ or –), another memory location (A–Z) can be selected. In our example, memory location "A" is to be overwritten. Acknowledge with the green "OK" button. The display now indicates the selected memory location, the assembly pressure and the retention time:

A:	45 BAR	1.0 SEC
MEMORY	CHANGE	SELECT

6. The memorising procedure is completed. The start button is now ready (lights up). The memorised assembly procedure can now begin as described from paragraph 2 in the section "Assembly of EO-2 functional nuts", "Pre-assembly of PSR/DPR rings" or "flaring tubes".

Retrieving memory locations:

e.g. Memory location "A".

1. The display shows the data of the last setting (random example):

DPR	TUBE-O.D.: 10 MM
MEMORY	CHANGE SELECT

2. Press left-hand yellow "MEMORY" button. The start button is now not operating. The display now always shows memory location "A":

A:	45 BAR	1.0 SEC
-	+ OK	

3. With a yellow button (+ or –), select the required memory location and acknowledge with the green "OK" button:

A:	45 BAR	1.0 SEC
MEMORY	CHANGE	SELECT

4. The start button is now ready (lights up). The assembly procedure can now begin as described from paragraph 2 in the sections "Assembly of EO-2 functional nuts", "Pre-assembly of PSR/DPR rings" or "flaring tubes".

Display during operation (Example):

LL	TUBE-O.D.: 10 MM
30° C	6 BAR ABORT

or

A:	45 BAR	1.0 SEC
30° C	6 BAR	ABORT

Oil temperature and pressure are shown for control. The current assembly procedure can be interrupted at any time with the green "ABORT" button or with the left-hand foot operating switch.

Display alarms:

TO LITTLE ASS. TRAVEL
INCOMPETE! CONTINUE

Check the assembly. For example, if pre-assembly action was carried out without tool or without progressive ring and nut. Press green "CONTINUE" button.

TOO HIGH PRESSURE
OVERTIGHTENED! CONTINUE

This image only appears in case of displacement-controlled assembly types LL and DPR. For example, if an already assembled tube has been inserted. Press green "CONTINUE" button.

FLARE	TUBE-O.D.: 16 MM
WRONG FIXTURE!	

The inserted fixture does not fit to the selected assembly type. The check of the fixture is valid only for assemblies of the EO standard range. Insert the correct fixture. The "during operation" display will be shown. The start button is now ready (lights up).

INSUFFICIENT OIL LEVEL

Switch off the unit. Check for leaks. Refill with oil.

OIL TEMPERATURE TOO HIGH

Switch off the unit and leave to cool.

EOMAT III assembly and flaring machine with electronic control

Ordering

Type	Order code
EOMAT III Basic machine Ready to use, including operation manual Filled with hydraulic oil Without EO assembly fixture/Flaring fixture Without tools for EO-assembly/37° flaring Basic machine 400 V, 3 Phase, 50 Hz Basic machine 230 V, 1 Phase, 50 Hz	EOMATIII/A380VX EOMATIII/A220VX
Fixture for PSR/DPR/EO-2 assembly	EOMATSCHNEIDRX
37° Flaring fixture for Triple-Lok®	EOMATBOERDELBX
Foot switch for use with long tubes	EOMATIIIFUSSX
EOMAT III promotion leaflet UK	4043-1/UK
EOMAT III promotion leaflet DE	4043-1/DE
EOMAT III operating manual UK/DE/FR/IT	4043-OM/UK/DE/FR/IT

Assembly fixtures, tools, cone gauges, and lubricant must be ordered separately

Assembly tools for PSR/DPR/EO2 see page H5.

37° flaring tools for Triple-Lok® see page H28.

Spare parts

Type	Order code
Fixing clip for MOK	EOMAT/CLIP
37° flaring pin	EOMAT/FLAREPIN
O-ring for flaring pin	EOMAT/FLAREORING
Tube stop assembly for flaring block	EOMAT/FLAREHOUSING
Oil filter	G01991
air breather filter for oil tank	EOMATIII/AIRFILTER
Emergency cut off switch	EOMATIII/NOTAUS
Control unit complete machine control assembly including front panel, display, pushbuttons	EOMAT3
Pressure/temperature sensor	SCPT-600-10-07



Assembly tooling

EO PSR/DPR and EO-2 assembly tools for EOMAT/EO-KARRYMAT



Assembly cone MOK



Tube locating plate GHP



Cone gauge conu for MOK



Assembly fixture must be installed on EOMAT II/III

Size		Order code			
Series	Tube o.d.	Assembly cone for EO PSR/DPR	Assembly cone for EO2/MOK/EO-2 ⁴⁾	Backing plates GHP	Cone gauges KONU
LL³	4	MOK04LLX	same as MOK for PSR/DPR	GHP04X	KONU04+05LLX
	6	MOK06LLX		GHP06X	KONU06+08LLX
	8	MOK08LLX		GHP08X	
	10	MOK10LLX		GHP10X	KONU10+12LLX
	12	MOK12LLX		GHP12X	
L	6	MOK06LX	same as MOK for PSR/DPR	GHP06X ¹	KONU06+08L/SX ¹
	8	MOK08LX		GHP08X ¹	KONU10+12L/SX ¹
	10	MOK10LX		GHP10X ¹	
	12	MOK12LX		GHP12X ¹	KONU15+18LX
	15	MOK15LX		GHP15X	
	18	MOK18LX	GHP18X	KONU22+28LX	
	22	MOK22LX	GHP22X		
	28	MOK28LX	MOKEO228LX	GHP28X	KONU35+42LX
	35	MOK35LX	MOKEO235LX	GHP35X ²	
42	MOK42LX	MOKEO242LX	GHP42X ²		
S	6	MOK06SX	same as MOK for PSR/DPR	GHP06X ¹	KONU06+08L/SX ¹
	8	MOK08SX		GHP08X ¹	KONU10+12L/SX ¹
	10	MOK10SX		GHP10X ¹	
	12	MOK12SX		GHP12X ¹	KONU14+16SX
	14	MOK14SX		GHP14X	
	16	MOK16SX	GHP16X	KONU20+25SX	
	20	MOK20SX	GHP20X		
	25	MOK25SX	MOKEO225LX	GHP25X	KONU30+38SX
	30	MOK30SX	MOKEO230LX	GHP30X	
	38	MOK38SX	MOKEO238LX	GHP38X	

Flaring tools see 1015 machine

1. Backing plates, cone gauges and flaring die sets for series L and S for tube outer diameter 6, 8, 10 and 12 are the same.
2. **Note:** For the assembly of EO-2 functional nuts FM 35L and FM42L the two-part backing plates GHP 35 and 42 must be used.
3. Assembly tools for LL-series for EOMAT III only.
4. Special MOK for easy tube insertion.

Tool mounting rack

Practical rack for storing 10 pieces each assembly cone MOK and backing plate GHP.

Type	Order code
Tool mounting rack for GHP and MOK	EOMATWERKZEUGAUFN.X



Ferulok assembly tools for EOMAT/EO-KARRYMAT



Assembly cone



Back-up plate

Size		Order code	
Dash size	Tube O.D. inch	Assembly cone	Back-up plate
4	1/4	975867-4	976521-4
6	3/8	975867-6	976521-6
8	1/2	975867-8	976521-8
10	5/8	975867-10	976521-10
12	3/4	975867-12	976521-12
14	7/8	975867-14	976521-14
16	1	975867-16	976521-16
20	1 1/4	975867-20	976521-20
24	1 1/2	975867-24	976521-24
32	2	975867-32	976521-32

Assembly tools for inch tube bite type FERULOK.
 FERULOK fittings see TFD US-Catalogue 4300.
 Machine setting according to correspondant size EO DPR.



F2 forming machine for EO2-FORM high pressure tube connections

The EO2-FORM F2 machine is designed to economically cold-form hydraulic tube for EO2-FORM connections. During this process, the tube end is compressed in between forming dies. This results in a special tube profile which matches the genuine EO-2 fitting components. The use of EO-2 seals provides leak-free performance and full interchangeability to the complete Ermeto Original product range according to DIN EN ISO 8434-1/ DIN 2353.

EO2-FORM is an attractive solution for high pressure tube connection that combines the advantages of welding, flaring and the proven EO-2 technology. The rigidity and low tightening torques of a weld connection are achieved by the unique cold forming process. Unlike other flaring systems, the deformation for EO2-FORM connections is relatively small and much more a compression process than flaring. This results in a high strength of the mechanical connection. During fitting assembly, standard EO-2 seals are fitted onto the tube end. The EO-2 seal achieves leakfree performance even under severe working conditions. For easy operation and high efficiency, the EO2-FORM process is completely automated. Manual adjustment of tools or pressure settings is not required. To assure reliable function, the machine has a powerful drive and the tools are made of high-strength material. The EO2-FORM F2 machine is designed for practical workshop use. Tools are available in a wide range and the short clamping length allows compact tube bends. Special tube treatment, heat or chemicals are not required. Zinc-plated tube can be used. A practical tool compartment inside the machine housing allows orderly and clean tool storage.

The EO2-FORM F2 machine is suitable for almost any hydraulic tube material in metric dimensions from 6 mm to 38/42 mm tube OD. Depending on tube dimension and material, the deformation is done in around 10 seconds. Total cycle time is

15 seconds on average. All machine components, including the hydraulic power pack, are integrated into the machine housing. The only external connection is the electrical power supply. To allow transportation, the machine is mounted on wheels.



F2 forming machine for EO2-FORM high pressure tube connections

Specifications

Cold-forming of hydraulic tube-ends

- Elastomerically sealed high pressure tube connection using EO-2 seal element
- suitable for EO tube fittings according to DIN EN ISO 8434-1
- Tube dimensions (tube OD × wall thickness mm)
- steel tube ST37.4: 6 × 1 to 38 × 7/42 × 4. Stainless steel tube 1.4571: 6 × 1 to 38 × 5/42 × 3
- exotic tube materials, such as CuNiFe or Super-Duplex on request
- Cycle time: 15 to 20 seconds
- standard power supply: 400V 50Hz
- Dimensions: Width 600 mm, height 115 mm, depth 660 mm Weight: approx. 300 kg.

Features, advantages and benefits

1. **Process/Product concept** – The EO2-FORM technology is not a stand-alone machine or a new fitting system. It is a product extension of the EO-2 range which has existed since 1993. Exactly the same seal elements are used.
2. **Cost saving** – Compared to welding or brazing, EO2-FORM is much less time consuming. Special tube preparation and finishing are not necessary. Cold forming uses only a fraction of the energy needed for brazing or welding.
3. **Superior vibration resistance** – The patented EO2-FORM process achieves a smooth structural transformation of the tube wall. There are no sharp edges or notches to reduce the vibration resistance.
4. **Superior mechanical strength** – The working contact area of the

EO2-FORM connection is the flat front surface of the metal support ring which is made of heat-treated, high-strength steel or stainless steel. This provides superior mechanical strength without settling, loosening or need for re-tightening.

5. **Single-button-operation** – Tube clamping and forming process are completely automated. The operator does not need to adjust the tooling. A start button is all that is needed to operate the machine.
6. **Universal** – The EO2-FORM machine can cold-form all common steel and stainless steel tube materials for hydraulic pipework. Even exotic materials such as CuNiFe or Super-Duplex can be formed. EO2-FORM tools cover metric tube sizes from 6 to 42 mm OD.
7. **Quick tool change** – Simple hand tools allow easy replacement of forming pin and dies. All tools are stored in a practical compartment inside the machine housing.
8. **Thin-wall tube** – The process is limited to a minimum wall thickness of 1 mm. No additional sleeves for thin-wall tube are required.
9. **Short tube ends** – The compact clamping device and special dies are suitable for machining complex tube bends.
10. **Noise/energy loss reduction** – The EO2-FORM process results in a smooth inner contour of the tube. Less pressure drop, heat and noise is created. No hidden corners allow the accumulation of air, dirt or other sources of trouble.
11. **Clean** – The EO2-FORM process is environmental clean and safe.

As no heat is used, hazards from fumes or heat do not occur.

12. **Zinc plated tubing** – The EO2-FORM process allows the use of zinc-plated tubing. The cost for cleaning or painting are saved.
13. **Quality** – Tube clamping and tool functions are fully automated. Proper joint geometry and seal dimensions are achieved by using standard EO-2 sealing rings. Therefore high and consistent quality is achieved without manual adjustment.
14. **Proven Technology** – Since 1993, millions of EO-2 fittings have operated worldwide under heavy duty conditions, providing leak-free hydraulic systems.
15. **No restrictions** – The process allows to use EO-2 elastomeric sealing technology even for applications where bite-type connectors are not permitted by safety standards, for example hydraulic presses, cranes, lifts or ship canal systems locks.
16. **Approved** – Both EO-2 high pressure tube fittings and the EO2-FORM process are tested and approved by independent organisations such as Germanischer Lloyd, Det Norske Veritas (DNV) and others.
17. **Applications** – Many customers already appreciate the easy assembly characteristics and leak-free performance of EO-2 fittings. EO2-FORM allows the use of this elastomeric sealing technology even for applications where bite-type connectors are not admitted by safety standards, like for hydraulic presses, cranes, lifts or ship canal systems/locks. Compared to welding or brazing, the EO2-FORM process is much faster and more comfortable.

Assembly tooling

F2 Forming machine for EO-2-FORM high pressure tube connections

Ordering

Type	Order code
Forming machine F2, ready to use, including operation manual, without tooling. Cold-forming of EO-2-FORM connections In special transport container Power supply 400 V/50 Hz/3-Phases	EO2FORMF2400V
Lubricant for tools Volume 0,1 L	1040LUBCAN
Lubricant for tools Volume 1,0 L	1040LUBSS
EO2-FORM F2 promotion leaflet UK	4028/UK
EO2-FORM F2 promotion leaflet DE	4028/DE
Operating manual UK/DE/FR/IT	4029/UK/DE/FR/IT
Foot switch	F2/FOOTSWITCH

EO2-FORM machines are shipped in a special container which should be kept for all transports to avoid damage.

Ordering

Type	Order code
Holder for forming pin	F2/PINHOLDER
Holder for clamping die segments	F2/DIEHOLDER
Oil filter	F2/OILFILTER
Air filter	F2/AIRFILTER
Top tray	F2/TOPTRAY
Emergency stop switch (red)	F2/STOPSWITCH
“Start” switch (black with symbol)	F2/STARTSWITCH
“On” switch (green)	F2/ONSWITCH
“Reset” switch (blue)	F2/RESETSWITCH
“Off” switch (red)	F2/OFFSWITCH
Front panel counter	F2/FRONTCOUNTER
Front wheel	F2/FRONTROLL
Back wheel	F2/BACKROLL
High pressure hose	F2/HOSE
Pin for clamping die	F2/DIEBOLT
Pin for forming pin	F2/PINBOLT
Locking screw for forming pin	F2/PINSCREW



Foot switch



Holder for forming pin



Holder for clamping die segments



Pin for forming pin

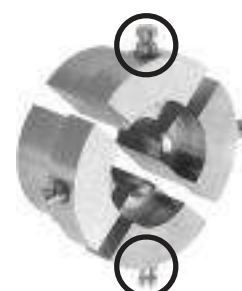

Pin for clamping die

F2 Forming machine for EO2-FORM high pressure tube connections



Clamping die set MF2EO-2



Forming pin BF2EO-2

Tube O.D. Ø	Clamping dies for steel and stainless steel tubes Order code	 Ø × s	Forming pin for steel tubes Order code	Forming pins for stainless steel tubes Order code ¹⁾
06-L/S	MF2EO206	06 × 1 06 × 1.5	BF2EO206X1S BF2EO206X1.5S	BF2EO206X1SS BF2EO206X1.5SS
08-L/S	MF2EO208	08 × 1 08 × 1.5	BF2EO208X1S BF2EO208X1.5S	BF2EO208X1SS BF2EO208X1.5SS
10-L	MF2EO210	10 × 1 10 × 1.5	BF2EO210LX1S BF2EO210LX1.5S	BF2EO210LX1SS BF2EO210LX1.5SS
10-S	MF2EO210	10 × 2 10 × 3	BF2EO210SX2S BF2EO210SX3S	BF2EO210SX2SS
12-L	MF2EO212	12 × 1.5 12 × 2	BF2EO212LX1.5S BF2EO212LX2S	BF2EO212LX1.5SS BF2EO212LX2SS
12-S	MF2EO212	12 × 2 12 × 3	BF2EO212SX2S BF2EO212SX3S	BF2EO212SX2SS BF2EO212SX3SS
15-L	MF2EO215	15 × 1 15 × 1.5 15 × 2	BF2EO215X1S BF2EO215X1.5S BF2EO215X2S	BF2EO215X1.5SS BF2EO215X2SS
16-S	MF2EO216	16 × 2 16 × 2.5	BF2EO216X2S BF2EO216X2.5S	BF2EO216X2SS BF2EO216X2.5SS
18-L	MF2EO218	18 × 1.5 18 × 2	BF2EO218X1.5S BF2EO218X2S	BF2EO218X1.5SS BF2EO218X2SS
20-S	MF2EO220	20 × 2 20 × 2.5 20 × 3 20 × 3.5	BF2EO220X2S BF2EO220X2.5S BF2EO220X3S BF2EO220X3.5S	BF2EO220X2SS BF2EO220X2.5SS BF2EO220X3SS
22-L	MF2EO222	22 × 1.5 22 × 2	BF2EO222X1.5S BF2EO222X2S	BF2EO222X1.5SS BF2EO222X2SS
25-S	MF2EO225	25 × 2.5 25 × 3 25 × 4	BF2EO225X2.5S BF2EO225X3S BF2EO225X4S	BF2EO225X2.5SS BF2EO225X3SS
28-L	MF2EO228	28 × 2	BF2EO228X2S	BF2EO228X2SS
30-S	MF2EO230	30 × 3 30 × 4	BF2EO230X3S BF2EO230X4S	BF2EO230X3SS BF2EO230X4SS
35-L	MF2EO235	35 × 2 35 × 3	BF2EO235X2S BF2EO235X3S	BF2EO235X2SS BF2EO235X3SS
38-S	MF2EO238	38 × 4 38 × 5 38 × 6/7	BF2EO238X4S BF2EO238X5S BF2EO238X6S	BF2EO238X4SS BF2EO238X5SS
42-L	MF2EO242	42 × 2 42 × 3	BF2EO242X2S BF2EO242X3S	BF2EO242X2SS BF2EO242X3SS

Please select clamping die and forming pin according to tube dimension and material.

1) All forming pins for stainless steel tubing are marked with a blue dot on front surface.



Manual flaring tools for Triple-Lok® tubes

Flaring tool selection guide



Manual flaring devices are available for on-site assembly and field repair of Triple-Lok® tube connections.

Manual flaring tools range from simple impact flarers to handpump-operated workshop devices. Flaring result and fitting performance depends strongly on the skill and effort of operator. Hand flaring tools are not recommended for efficient industrial production.

Features, advantages and benefits of hand flaring tools

- 1. Flexible** – Manual flaring tools are portable and do not need any power supply. Therefore they are ideal for on-site assembly and field repair.
- 2. Special** – Each device has been especially developed to match Parker Triple-Lok® standards. The tube connections will fit properly without rework.

How to select the ideal flaring device for your application:

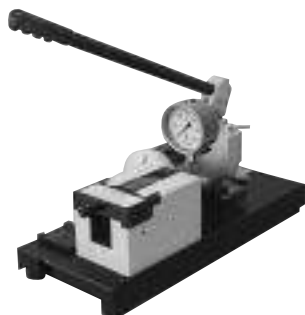
	Hand flaring tools 1004/210A	Impact flaring tool	Flaring device 1015
			
Assembly method Triple-Lok® O-Lok®	impact flaring not suitable	impact flaring not suitable	conventional flaring not suitable
Tube specification Material Dimension metric tube Dimension inch tube Limitations	copper, steel 6 to 16 mm (1004) 1/8" to 5/8" (210A) see specification	copper, steel, stainless steel 6 to 38 mm 1/4" to 1 1/2" see specification	steel, stainless steel 6 to 38 mm 1/4" to 1 1/2" see specification 1015
Tools Clamping dies Flaring pin	one device integral part of device	vice block pin plus hammer	Flaring die M15 ... (same dies used EOMAT) integral part of device
Operation Flaring Process control Tube clamping	hammer blows manual manual clamping	hammer blows manual manual	handpump pressure according to chart automatic clamping
Specifications Design Weight Dimension (W x L x H)	flaring device for use in vice approx. 1.5 kg –	Hand tools for use in vice – –	desktop approx. 40 kg 250 x 600 x 600 mm
Performance Overall cycle time Quality	approx. 60 secs. dependant on operator	approx. 60 secs dependant on operator	approx. 60 secs consistent result
Application	on-site repair jobs only; Limited to small dimensions. Limited to single assemblies, not for industrial production, emergency repairs until industrial flared tube is available for replacement.		Efficient for on-site flaring of small quantities not for mass production

Manual flaring tools for Triple-Lok® tubes

These 37° flaring tools are for use with copper, aluminum alloy, and thin wall steel or stainless steel tubes. A vice block is clamped together with the tube end into a vicener. Flaring pin is used with a hammer. Separate tooling sets for each tube size in metric and inch dimensions are available.

These hand tools are suitable for small on-site repair jobs. They are not suitable for thick-wall tubing and industrial production. A rigid vice must be available at the assembly site.

Features, advantages and benefits

1. **Light** – Hand flaring tools can be used at any assembly site where a proper workshop is not available
2. **Quick** – Hand flaring tools can be used for temporary repair until a proper spare tube has been made by machine

Applications

- Field repair of agricultural and construction vehicles
- Small, local repair workshops
- Mobile repair service

Combination impact flarer 1004 for small dimension metric tube



Specifics

Design: Hand flaring tool for small on-site repair jobs
Operation: Flaring pin Impact
37° Flaring: Triple-Lok® connection – ISO 8434-2/ SAE J514
Tube material: copper, aluminum and low carbon steel
Tube diameter: 6 to 16 mm metric tube
Wall thickness: max 15% of tube O.D.
Requirements: Rigid vice and hammer

Operation

1. Clamp tube end flush in block halves
2. Clean and lubricate tube end and flaring pin
3. Form the flare by a few sharp hammer blows
4. Use pre-flaring pin for tube O.D. 20 mm/3/4" and larger
5. Release vice and unclamp tube

See chapter E for detailed instructions on Triple-Lok® assembly

Ordering

Type	Order code
Combination impact flarer Complete device including Combination dies and pin	1004-74M
Tool lubricant 0.1L can	1040LUBCAN

Combination impact flarer 210A for small dimension inch tube



Specifics

Design: Hand flaring tools for small on-site repair jobs
Operation: Flaring pin Impact
37° Flaring: Triple-Lok® connection – ISO 8434-2/ SAE J514
Tube material: copper, aluminum and low carbon steel
Tube diameter: 1/8" to 5/8" inch
Wall thickness: max 15% of tube-O.D.
Requirements: Rigid vice and hammer

Operation

1. Clamp tube end flush in block halves
2. Clean and lubricate tube end and flaring pin
3. Form the flare by a few sharp hammer blows
4. Release vice and unclamp tube

See chapter E for detailed instructions on Triple-Lok® assembly

Ordering

Type	Order code
Combination impact flarer Complete device including Combination dies and pin	210A
Tool lubricant 0.1L can	1040LUBCAN



Impact flaring tools for metric and inch tube

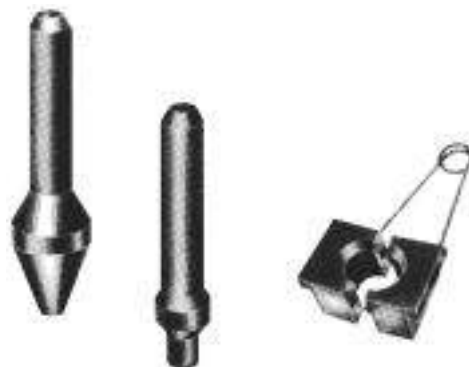

Specifications

Design: Hand flaring tools for small on-site repair jobs

Operation: Impact flaring pin

37° Flaring: Triple-Lok® connection – ISO 8434-2/ SAE J514

Tube material: copper, aluminum, steel and stainless steel tube

Tube diameter: 6 to 38 mm/1/4" to 1 1/2"

Wall thickness: max 15% of tube-O.D., max 10% of tube O.D. for tubes larger 20 mm tube O.D.

Requirements: Rigid vice and hammer

Operation

1. Clamp tube end flush in block halves
2. Clean and lubricate tube end and flaring pin
3. Form the flare by a few sharp hammer blows
4. Use pre-flaring pin for tube O.D. 20 mm/3/4" and larger
5. Release vice and unclamp tube

See chapter E for detailed instructions on Triple-Lok® assembly

Tools for metric tube				Tools for inch tube			
Rohr A.D. mm	Pre-flaring pin Order code	Flaring Order code	Vice block Order code	Tube-O.D. inch	Pre-flaring pin Order code	Flaring Order code	Vice block Order code
06		P17408	M27406	1/4"		P17408	M04742
08		P17408	M05742	5/16"		P17408	M05742
10		P17408	M27410	3/8"		P17408	M06742
12		P17414	M27412	1/2"		P17414	M08742
14		P17414	M27414				
15		P17414	M27415				
16		P17414	M27416	5/8"		P17414	M10742
18		P17418	M27418				
20	P1E	P17418	M27420	3/4"	P1E	P17418	M12742
25	P1E	P17422	M27425	1"	P1E	P17422	M16742
30	P1E	P17432	M27430		P1E		
32	P1E	P17432	M27432	1.1/4"	P1E	P17432	M20742
38	P1E	P17438	M24742	1.1/2"	P1E	P17438	M24742

Type	Order code
Tool lubricant 0,1L can	1040LUBCAN

Portable 37° flaring device 1015

The 1015 flarer is a portable device for on-site 37° flaring of tube for Triple-Lok® connections. It allows flaring of even large dimension steel and stainless steel tube at assembly sites where Parflange® technology is not available.

The 1015 flarer consists of a hydraulic cylinder and a hand-pump. The hydraulic flaring pressure can be read on a gauge. The 1015 flaring device comes as one unit with all components firmly attached to a practical carrying frame. Flaring tools consist of a die set for each tube O.D. and must be ordered separately. The flaring pin is integrated into the device.



Specifications

Design:	Portable hand flaring device for on-site assembly
37° Flaring:	Triple-Lok® connection – ISO 8434-2/SAE J514
Tube material:	copper, aluminum, steel and stainless steel tube
Tube diameter:	metric: 6 to 38mm Inch: 1/4" to 1 1/2"
Maximum capacity:	Steel tube 38 × 4 mm/1 1/2" × 0.156" (tube O.D. × wall thickness) Stainless steel tube 25 × 3 mm/1" × 0.095"
Tube specification:	Fully annealed seamless cold drawn or welded precision tube
Tools:	Flaring pin is integral part of machine Clamping dies "M15 ..." (Also used on EOMAT)
Tool lubrication:	Lubricant 1040LUBCAN/1040LUBSS
Hydraulic oil:	HLP 23 0.5L (filled before delivery)
Dimensions:	250 × 600 × 600mm
Weight:	40 kg

Features, advantages and benefits

1. **Flexible** – The 1015 flaring device can be used at any assembly site where a proper workshop is not available
2. **Economic** – The 1015 device closes the gap in between hand flaring and professional Parflange® machines. It is far less hard work than hand flaring and achieves consistent flaring quality.

Applications

- On-site assembly of small hydraulic systems
- Field repair of agricultural and construction vehicles
- Repair workshops and plant maintenance
- Mobile repair service

Operation

1. Clean and lubricate tube end and flaring pin
2. Lift the die fixture cover
3. Insert clamping dies and close die fixture cover
4. Push in tube to stop
5. Form the flare by operating handpump
6. Refer to chart on machine for correct pressure
7. Open cover and lift out dies to remove tube

See chapter E for detailed instructions on Triple-Lok® assembly

Ordering

Type	Order code
Manual flaring device 1015 (Complete unit with handpump and flaring pin, tank filled with hydraulic oil, without die sets including operation manual)	1015-1C
Tool lubricant 0.1L can	1040LUBCAN
Tool lubricant 1.0L refill	1040LUBSS
1015 promotion leaflet UK/DE	4370/UK/DE
1015 operating manual UK/DE/FR/IT	4390-B3

Spare parts

Type	Order code
Flaring block complete	1015/FLAREBLOCK
Spare flaring Pin	1015/FLAREPIN
O-ring for flaring pin	1015/B08
Closure handle	1015/B11
Tube stop assembly	1015/B12
Spring with screws	1015/B13
Pressure gauge	1015/MANO

37° flaring tools for 1015 device and EOMAT II/III machine



Flaring die set M1574

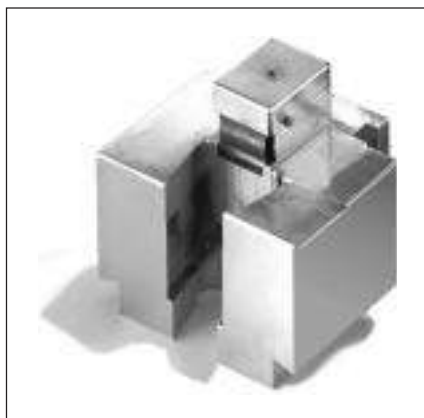

Flaring fixture must be installed on EOMAT II/III

Flaring dies for metric tube		Flaring dies for inch tube	
Tube O.D. mm	Order code	Tube O.D. in.	Order code
6	M157406-1	1/4"	M047415-1
8	M157408-1	5/16"	M157408-1
10	M157410-1	3/8"	M067415-1
12	M157412	1/2"	M087415
14	M157414		
15	M157415		
16	M157416	5/8"	M107415
18	M157418		
20	M157420	3/4"	
25	M157425	1"	M167415
30	M157430		
32	M157432	1.1/4"	M207415
38	M157438	1.1/2"	M157438
42	M157442		

Flaring diameters acc. to ISO 8434-2/SAE J514 for Triple-Lok®.

Flaring pins are integrated in 1015 device and flaring fixture for EOMAT II/III machine.

Flaring dies are **not** interchangeable with Parflange® tools for 1025/1040-machines.

Assembly machines for O-Lok® and Triple-Lok®

Parflange® machine selection guide

Parflange® 1025 and Parflange® 1040 are orbital flaring machines designed to cold-form high pressure tube connections. The unique feature of the patented Parflange® process is that the deformation of the tube end is achieved by rolling rather than by just pushing a tool into the tube end. The Parflange® machine smoothly compresses the tube material and achieves a high strength joint with a polished surface of the tube end. O-Lok® sleeves are firmly fixed onto the tube end, resulting in a very rigid high-pressure tube connection.

Features, advantages and benefits

- 1. Superior sealing performance** – The patented Parflange® process achieves a sealing surface of unique surface quality and mechanical strength.
- 2. Superior vibration resistance** – Unlike conventional flaring, the Parflange® process results in a rigid connection of the O-Lok® sleeve on the tube-end. Parflange®/O-Lok® connections perform much better under reversed bending stress conditions.
- 3. Easy to use** – No programming or adjustments necessary. High quality results are consistently achieved without manual adjustments.
- 4. Cost saving** – Compared to brazing or welding, orbital flanging is much less time consuming. Special tube preparation and finishing are not necessary.

Flanging uses only a fraction of the energy needed for brazing or welding.

- 5. Clean** – The Parflange® process is environmental clean and safe. As no heat or chemicals are used, hazards from fumes or heat do not occur.
- 6. Zinc plated tubing** – The Parflange® process allows the use of zinc-plated tubing. The cost for cleaning, post process plating or painting is saved.
- 7. Process/Product concept** – Parflange® machines are especially designed to match Parker O-Lok® and Triple-Lok® standards. Machine, tools and products are fine-tuned for reliable performance.
- 8. Proven technology** – For more than 10 years, hundreds of Parflange® machines have operated worldwide under heavy duty workshop conditions.

How to select the ideal Parflange® Machine for your application:

Machine selection chart	Parflange® 1025		Parflange® 1040
Assembly method Triple-Lok® O-Lok®	Orbital flaring 37° Orbital flanging 180°		Orbital flaring 37° Orbital flanging 180°
Tube specification Material Dimension metric tube Dimension inch tube Limitations	Steel, Stainless Steel 6 × 1 to 38 × 4 mm/42 × 3 mm 1/4" × 0.028" to 1 1/2" × 0.120" not suitable for 1.4571 (316 Ti) tube see specification 1025		Steel, Stainless Steel 6 × 1 to 38 × 4 mm/42 × 3 mm 1/4 × 0.028 to 1 1/2" × 0.120" not suitable for 1.4571 (316 Ti) tube see specification 1040
Tools Clamping dies Flaring/flanging pin	special Parflange® tools M40 ... (old: M30 ...) B30 ...		special Parflange® tools M40 ... B30 ...
Operation Setting Standard sleeve feeding Optional sleeve feeding Tube clamping Flanging/Flaring Process control	automatic adjustment manual loading not available manual clamping automatic drive semi automatic		automatic adjustment manual loading O-Lok® sleeve feeder hydraulic clamping automatic drive fully automatic
Specifications Design Weight Dimension (W × L × H)	desktop approx. 85 kg 390 × 670 × 460 mm		stand-alone approx. 300 kg 700 × 840 × 1035 mm
Performance Version Voltage Overall cycle time Design Weight	1.5 kW 400 V 3 Phase approx. 50 secs. approx. desktop 85 kg	1.1 kW 230 V 1 Phase approx. 60 secs. desktop 85 kg	4 kW 400 V 3 Phase approx. 15 secs. stand-alone 300 kg
Application	Ideal for projects and workshop use and maintenance High quality result No mass production	on-site repair jobs where 3phase power supply is not available	Efficient production machine for low-cost and high-quality assembly



Parflange® 1025 workshop machine for O-Lok® and Triple-Lok®



The Parflange® 1025 machine is designed to cold-form high pressure tube connections for O-Lok® and Triple-Lok® connection. It uses the patented Parflange® orbital flaring process. The Parflange® 1025 machine smoothly compresses the tube material and achieves a high strength joint with a polished surface of the tube end. O-Lok® and SAE flange sleeves are firmly fixed onto the tube end, resulting in a very rigid high-pressure tube connection.

The 1025 is the smallest machine of the Parflange® machine programme. It is recommended for low-volume assembly jobs of small to medium tube dimensions. Maximum tube capacity is 38 x 4 mm/1 1/2" (steel tube) and 25 x 2.5 mm/1" stainless steel tube (3 Phase version). Its advantage is the quick and easy change of tooling and the simple operation without manual adjustments or programming. The machine is transportable so that it can be moved to any assembly site with electrical power supply.

The Parflange® 1025 comes ready to be used. Parflange® tools are purchased separately. For each tube dimension, special clamping dies and Parflange® pins are required.

Specifications

Purpose: 180° flanging for O-Lok® and 37° flaring for Triple-Lok®

Process:	Orbital flaring and flanging according to Parflange® process
Design:	Desktop machine for workshop use
Tube material:	steel and stainless steel tube
Tube diameter:	metric: 6 to 38 mm Inch: 1/4 to 1 1/2"
Maximum capacity:	Steel tube 42 x 3/1 1/2 x 0.120 (tube O.D. x wall thickness) Stainless steel tube 25 x 3/1 x 0.095
Tube specification:	fully annealed seamless cold drawn or welded precision tube
Limitations:	Not suitable for Titanium-Stabilised stainless steel tube material (316Ti, 1.4571)
Operation:	Manual clamping, automatic flanging/flaring
Cycle time:	approx. 15 to 20 secs.
Tools:	Flaring pin B30 ... and clamping dies M40 ...
Tool clamping:	Manual, by eccentric lever
Tool lubrication:	Automatic lubrication device
Lubricant:	1040LUBSS (filled when delivered)
Hydraulic oil:	HLP 23 0.5L (filled when delivered)
Installation:	rigid workbench and electrical power supply required
Dimensions:	390 x 670 x 460 mm
Weight:	60 kg

Features, advantages and benefits

1. **Superior sealing performance** – The patented Parflange® process achieves a sealing surface of unique surface quality and mechanical strength.
2. **Superior vibration resistance** – Unlike conventional flaring, the Parflange® process results in a rigid connection of the O-Lok® sleeve on the tube-end. Parflange®/O-Lok® connections perform much better under reversed bending stress conditions.
3. **Easy to use** – No programming or adjustments necessary. High quality results are consistently achieved without manual adjustments.
4. **Quality** – Machine setting, tool control and even lubrication are fully automated so that high and consistent quality results are achieved without manual adjustments.
5. **Small bending radii** – The compact clamping device and special dies are suitable for flanging short tube ends.
6. **Cost saving** – Compared to brazing or welding, orbital flanging is much less time consuming. Special tube preparation and finishing are not necessary. Flanging uses only a fraction of the energy needed for brazing or welding.
7. **Clean** – The Parflange® process is environmental clean and safe. As no heat or chemicals are used, hazards from fumes or heat do not occur.
8. **Zinc plated tubing** – The Parflange® process allows the use of zinc-plated tubing. The cost for cleaning or painting can be saved.
9. **High tool lifetime** – The Parflange® 1025 machine is equipped with an automatic lubrication device. The tools will not wear rapidly if the operator does not lubricate regularly.
10. **Process/Product concept** – Parflange® machines are especially designed to match Parker O-Lok® and Triple-Lok® standards. Machine, tools and products are fine-tuned for reliable performance.
11. **Proven technology** – Since more than 10 years, hundreds of Parflange® machines have operated worldwide under heavy duty workshop conditions.

Applications

Workshop use, project work, plant maintenance, on-site assembly.

Not for efficient mass production

Ordering

Type	Order code
Parflange® 1025 Basic machine Ready to use, Including operating manual, Filled with hydraulic oil and lubricant Without Parflange® tools	
Basic machine 400 V, 3 Phase, 50 Hz	1025-380VTRI50
Basic machine 230 V, 1 Phase, 50 Hz	1025-220VNMONO50
1025 promotion leaflet UK	4390-P2-UK
1025 promotion leaflet DE	4390-P2-DE
1025 operating manual UK/DE/FR/IT	4395-B5

Parflange® machines are shipped in a special container which should be kept for all transports to avoid damage.

Spare parts

Type	Order code
Tool lubricant qty: 1L	1040/LUBSS
Hydraulic oil qty: 1L	1025/HYDROBT15
Drive belt	1025/028BELT
Came guide and with screw	1025/0281031
Hydraulic tank seal kit	1025/0281042
Lubrication kit	1025/028-1200



Parflange® 1040 production machine for O-Lok® and Triple-Lok®



The Parflange® 1040 is an orbital flaring machine designed to cold-form high pressure tube connections. The unique feature of the patented Parflange® process is that the deformation of the tube end is achieved by rolling rather than by just pushing a tool into the tube end. The Parflange® machine smoothly compresses the tube material and achieves a high strength joint with a polished surface of the tube end. O-Lok® and SAE flange sleeves are firmly fixed onto the tube end, resulting in a very rigid high-pressure tube connection.

The 1040 is the heavy-duty, mass production machine of the Parflange® machine programme. It is recommended for industrial production of all sizes Triple-Lok® and O-Lok® tube connections. Maximum tube capacity is 38 mm/1 1/2 tube O.D. The powerful drive, and the fast, automatic process allow short cycle times for efficient production. Its advantage is the quick and easy change of tooling and the simple operation without manual adjustments or programming. Tube clamping and tool lubrication are done automatically.

The Parflange® 1040 comes ready to be used. Parflange® tools have to be purchased separately. For each tube dimension, special clamping dies and Parflange® pins are required. The machine can be moved on wheels. Additionally to the electrical supply, an air pressure connection is required for the integrated lubrication device.

For industrial mass production of O-Lok® connections, a special sleeve feeder is available. This sleeve feeding device increases the productivity, particularly of high volume – single tube dimension jobs.

Specifications 1040

Purpose:	180° Flanging for O-Lok® and 37° Flaring for Triple-Lok®
Process:	Orbital flaring and flanging according to Parflange® process
Design:	Stand-alone machine for industrial production
Tube material:	steel and stainless steel tube
Tube diameter:	metric: 6 to 38 mm Inch: 1/4 to 1 1/2"
Maximum capacity:	Steel tube 38 × 5 mm/ 1 1/2" × 0.188 (tube O.D. × wall thickness) Stainless steel tube 38 × 4 mm/1 1/2" × 0.156
Tube specification:	fully annealed seamless cold drawn or welded precision tube
Limitations:	Not suitable with titanium stabilised stainless steel tube material (316Ti, 1.4571)
Operation:	Automatic clamping, automatic flanging/flaring Optional automatic sleeve feeder available
Cycle time:	approx. 15 to 20 secs.
Tools:	Flaring pin B30 ... and clamping dies M40 ...
Tool clamping:	automatic
Tool lubrication:	Automatic lubrication device
Lubricant:	1040LUBSS (filled when delivered)
Hydraulic oil:	HLP 23 XXL (filled when delivered)
Installation:	electrical power and compressed air (6 bar) supply required
Dimensions:	700 x 840 x 1035 mm
Weight:	306 kg

Applications

Industrial production of Triple-Lok® and O-Lok® connections, High quantity/large diameter assembly projects, Large diameter stainless steel assembly jobs

Features, advantages and benefits of the 1040

- Superior sealing performance** – The patented Parflange® process achieves a sealing surface of unique surface quality and mechanical strength.
- Superior vibration resistance** – Unlike conventional flaring, the Parflange® process results in a rigid connection of the O-Lok® sleeve on the tube-end. Parflange/O-Lok® connections perform much better under reversed bending stress conditions.
- Efficient** – The short cycle time and the automatic process allow efficient mass production.
- Quality** – Tube clamping, tool control and even lubrication is fully automated so that high and consistent quality results are achieved without manual adjustments.
- Low-cost mass production** – The machine can be equipped with an automated sleeve feeder. The Parflange® 1040 then is the perfect solution for low-cost mass production.
- Universal** – The Parflange® 1040 can do 37° flaring for Triple-Lok® connectors and flange tubes for both O-Lok® fittings (ORFS). Parflange® tools cover metric tube from 6 to 38 mm O.D. and inch tube from 1/4 to 1 1/2" O.D.
- Heavy duty** – The rigid machine design allows use for mass production of even large stainless steel tube connections.
- Easy to use** – The clamping and flanging process is fully automated. Manual tool manipulation is not required.
- Cost saving** – Compared to welding or brazing, orbital flanging is much less time consuming. Special tube preparation and finishing are not necessary. Flanging uses only a fraction of the energy needed for brazing or welding.
- Clean** – The Parflange® process is environmentally clean and safe. As no heat or chemicals are used, hazards from fumes or heat do not occur.
- Zinc plated tubing** – The Parflange® process allows the use of zinc-plated tubing. The cost for cleaning post process plating, or painting can be saved.
- High tool lifetime** – The Parflange® 1040 machine is equipped with an automatic lubrication device. The operator does not have to lubricate the tools regularly to prevent rapid wear.
- Process/Product concept** – Parflange® machines are especially designed to match O-Lok®, Triple-Lok® and SAE-flange standards. Machine, tools and products are fine-tuned for reliable performance.
- Proven technology** – For more than 10 years, hundreds of Parflange® machines have operated worldwide under heavy duty workshop conditions.

Ordering

Type	Order code
Parflange® 1040 Basic machine Ready to use, including operation manual, filled with hydraulic oil and lubricant Without Parflange® tools Basic machine 400 V, 3 Phase, 50 Hz	1040-EU400V
1040 promotion leaflet UK	4390-P1-UK
1040 promotion leaflet DE	4390-P1-DE
1040 operating manual UK/DE/FR/IT	4395-B11/ UK/DE/FR/IT

Feeder for O-Lok® sleeves (not suitable for Triple-Lok®)

Sleeve feeder	Order code
For attaching on Parflange® 1040 machine Complete kit including all connectors and installation/operating manual without sleeve feeding rails	1040-FEEDER
Sleeve feeding rails for 1040 sleeve feeder are ordered separately for each tube O.D.	
6 mm/1/4"	1040/025GS-04
8–10 mm/3/8"	1014/025GS-06
12 mm/1/2"	1014/025GS-08
14–15–16 mm/5/8"	1014/025GS-10
18–20 mm/3/4"	1014/025GS-12
22–25 mm/1"	1014/025GS-16
28–30–32 mm/1 1/4"	1014/025GS-20
35–35 mm/1 1/2"	1014/025GS-24

Spare parts

Type	Order code
Drive belt	1025/028BELT
Hydraulic oil filter cartridge	G01991
Tool lubricant qty: 1L	1040/LUBSS
Adjustable spray line	1040/LMC0102
Tube stop (lever only)	1040/0142205
Tube stop kit (complete assembly)	1040/0142228

Parflange® machines and feeders are shipped in special container which should be kept for all transports to avoid damage.



Tooling for Parflange® machines

Machine and tool selection



Parflange® 1025



Parflange® 1040

Parflange® 1025 machines flanging capacity for O-Lok®

Tube material	220 V 1.1 kW	380 V 1.5 kW
	Max. tube size mm (inch)	
Steel ST37	38 × 2 (1½ × .083)	38 × 3 (1½ × .120")
Stainless steel 304L/316L*	25 × 2 (1 × .083)	25 × 2.5 (1 × .095)
Steel ST52	25 × 2 (1 × .083)	25 × 2.5 (1 × .095)

Parflange® 1040 machines flanging capacity for O-Lok®

Tube material	Max. tube size mm (inch)
Steel ST37	38 × 5/50 × 3 (2 × .120)
Steel ST52	38 × 4 (1½ × .156)
Stainless steel 304L/316L*	38 × 4 (1½ × .156)

Parflange® 1025 machines flaring capacity for Triple-Lok®

Tube material	Elect. power of machine	
	220 V 1.1 kW	380 V 1.5 kW
Max. tube size mm (inch)		
Steel TU 37 B	38 × 4 (1½ × .120)	38 × 4 (1½ × .120)
Stainless steel 304L/316L* Steel TU 52 B	38 × 4 (1½ × .120)	38 × 4 (1½ × .120)
Stainless steel Duplex (or PW 400)	Not recommended	25 × 2.5 (1 × .095)

Parflange® 1040 machines flaring capacity for Triple-Lok®

Tube material	Elect. power of machine
	220/380 V 4 kW
Max. tube size mm (inch)	
Steel TU 37 B	38 × 4/42 × 3 (1½ × .120)
Steel TU 52 B	38 × 4/42 × 3 (1½ × .120)
Stainless steel 304L/316L*	38 × 4/42 × 3 (1½ × .120)
Stainless steel Duplex (or PW 400)	38 × 3.6

● Tooling for Parflange® machines

- Pins B 30 ... are common to all Parflange® machines
- Dies M 40 ... can be used on Parflange® 1040, Parflange® 1025, or Parflange® 1030 (Nb: M 30 dies have been phased out).
- Dies M 30 ... can be used only on Parflange® 1030 and 1025 machines
See table following for the selection of the correct pins and dies

Parflange® tool identification



Parflange® tools for O-Lok®

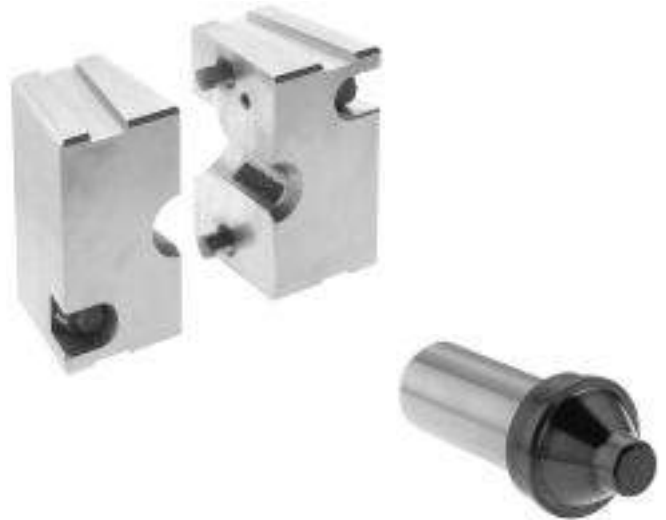

Parflange® tools for Triple-Lok®



Tooling for metric tubing

Metric die numbering system

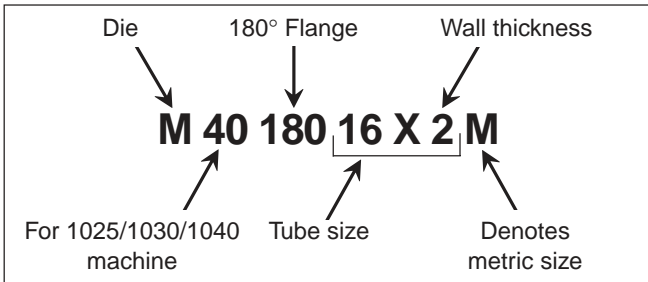

Metric pin numbering system

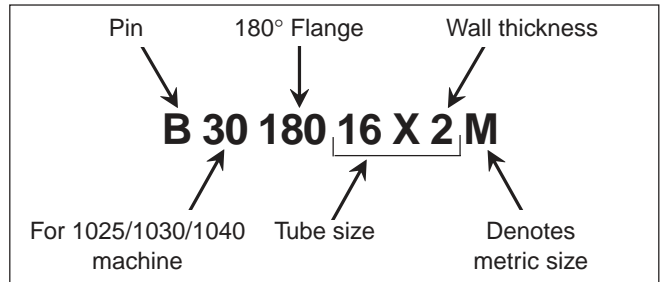

Tooling for inch tubing

Die numbering system

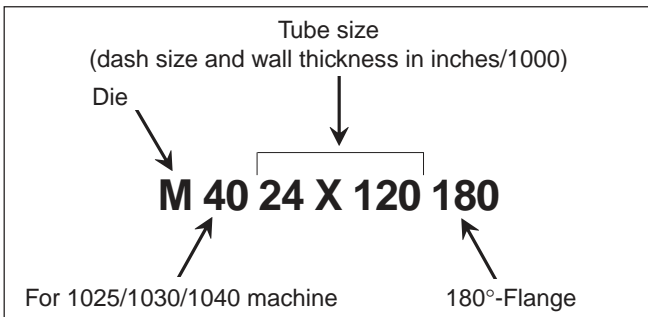

Pin numbering system

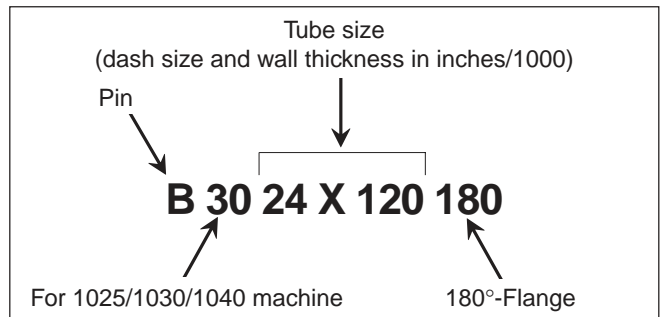

Parflange® tools for stainless steel tubes have different dimensions and are specially coated. These tools are marked with suffix "SS".

Assembly tooling

Parflange® tools for O-Lok®

Parflange® tooling – Order codes for Parflange® 1040, Parflange® 1025 and Parflange® 1030

Metric tube

Tube size (O.D. × wall thickness) mm	Flange pin Order code	1040 flange die Order code
6 × 1** 6 × 1.5	B3018006X1M B3018006X1.5M	M4018006X1M M4018006X1.5M
8 × 1** 8 × 1.5** 10 × 1** 10 × 1.5** 10 × 2	B3018008X1M B3018008X1.5M B3018010X1M B3018010X1.5M B3018010X2M	M4018008X1M M4018008X1.5M M4018010X1M M4018010X1.5M M4018010X2M
12 × 1** 12 × 1.5** 12 × 2**	B3018012X1M B3018012X1.5M B3018012X2M	M4018012X1M M4018012X1.5M M4018012X2M
15 × 1.5** 15 × 2	B3018015X1.5M B3018015X2M	M4018015X1.5M M4018015X2M
16 × 1 16 × 1.5** 16 × 2** 16 × 2.5	B3018016X1M B3018016X1.5M B3018016X2M B3018016X2.5M	M4018016X1M M4018016X1.5M M4018016X2M M4018016X2.5M
18 × 1 18 × 1.5** 18 × 2	B3018018X1M B3018018X1.5M B3018018X2M	M4018018X1M M4018018X1.5M M4018018X2M
20 × 2** 20 × 2.5** 20 × 3	B3018020X2M B3018020X2.5M B3018020X3M	M4018020X2M M4018020X2.5M M4018020X3M
22 × 1.5** 22 × 2 22 × 2.5	B3018022X1.5M B3018022X2M B3018022X2.5M	M4018022X1.5M M4018022X2M M4018022X2.5M
25 × 2** 25 × 2.5** 25 × 3 25 × 4	B3018025X2M B3018025X2.5M B3018025X3M B3018025X4M	M4018025X2M M4018025X2.5M M4018025X3M M4018025X4M
28 × 2 28 × 2.5	B3018028X2M B3018028X2.5M	M4018028X2M M4018028X2.5M
30 × 2 30 × 3** 30 × 4	B3018030X2M B3018030X3M B3018030X4M	M4018030X2M M4018030X3M M4018030X4M
32 × 3 32 × 4	B3018032X3M B3018032X4M	M4018032X3M M4018032X4M
35 × 3	B3018035X3M	M4018035X3M
38 × 3** 38 × 4** 38 × 5	B3018038X3M B3018038X4M B3018038X5M	M4018038X3M M4018038X4M M4018038X5M
50 × 3	B3018050X3M	M4018050X3M

Inch tube

Tube size (O.D. × wall thickness) inch	Flange pin Order code	1040 flange die Order code
1/4 × .028 1/4 × .035*** 1/4 × .049***	B3004X028180 B3004X035180 B3004X049180	M4004X028180 M4004X035180 M4004X049180
3/8 × .035*** 3/8 × .049*** 3/8 × .065***	B3006X035180 B3006X049180 B3006X065180	M4006X035180 M4006X049180 M4006X065180
1/2 × .035*** 1/2 × .049*** 1/2 × .065*** 1/2 × .083***	B3008X035180 B3008X049180 B3008X065180 B3008X083180	M4008X035180 M4008X049180 M4008X065180 M4008X083180
5/8 × .049*** 5/8 × .065*** 5/8 × .083*** 5/8 × .095***	B3010X049180 B3010X065180 B3010X083180 B3010X095180	M4010X049180 M4010X065180 M4010X083180 M4010X095180
3/4 × .049*** 3/4 × .065*** 3/4 × .083*** 3/4 × .095*** 3/4 × .109*** 3/4 × .120***	B3012X049180 B3012X065180 B3012X083180 B3012X095180 B3012X109180 B3012X120180	M4012X049180 M4012X065180 M4012X083180 M4012X095180 M4012X109180 M4012X120180
1 × .065*** 1 × .083*** 1 × .095*** 1 × .109*** 1 × .120*** 1 × .134**	B3016X065180 B3016X083180 B3016X095180 B3016X109180 B3016X120180 B3016X134180	M4016X065180 M4016X083180 M4016X095180 M4016X109180 M4016X120180 M4016X134180
1 1/4 × .095*** 1 1/4 × .109*** 1 1/4 × .120*** 1 1/4 × .134 1 1/4 × .148 1 1/4 × .156 1 1/4 × .188	B3020X095180 B3020X109180 B3020X120180 B3020X134180 B3020X148180 B3020X156180 B3020X188180	M4020X095180 M4020X109180 M4020X120180 M4020X134180 M4020X148180 M4020X156180 M4020X188180
1 1/2 × .065 1 1/2 × .083 1 1/2 × .095 1 1/2 × .109 1 1/2 × .120*** 1 1/2 × .134 1 1/2 × .156 1 1/2 × .188	B3024X065180 B3024X083180 B3024X095180 B3024X109180 B3024X120180 B3024X134180 B3024X156180 B3024X188180	M4024X065180 M4024X083180 M4024X095180 M4024X109180 M4024X120180 M4024X134180 M4024X156180 M4024X188180
2 × .083 2 × .095 2 × .120	B3032X083180 B3032X095180 B3032X120180	M4032X083180 M4032X095180 M4032X120180

Notes:

1) These sizes are presently available for flanging stainless steel tubing (AISI 304 L and 316 L). Use the suffix "SS" after the steel order code (Eg. B3018012X1.5MSS).

2) These sizes available in Parker USA for flanging stainless steel tubing (AISI 304 L and 316 L).

Parflange® tools for Triple-Lok®

Metric tube

Tube size (O.D. × wall thickness) mm	Flare pin Order code	Flare die Order code
6×1** 6×1.5	B300746X1M B300746X1.5M	M4007406M M4007406M
8×1** 8×1.5	B300748X1M B300748X1.5M	M4007408M M4007408aM
10×1** 10×1.5**	B3007410X1M B3007410X1.5M	M4007410M M4007410M
12×1	on request	
12×1.5** 12×2	B3007412X1.5M B3007412X2M	M4007412M M4007412M
15×1.5** 15×2	B3007415X1.5M B3007415X2M	M4007415M M4007415M
16×1.5** 16×2**	B3007416X1.5M B3007416X2M	M4007416M M4007416M
18×1.5** 18×2	 B3007418X2M	M4007419M M4007419X1.5M M4007418M
20×2** 20×2.5** 22×2	B3007420X2M B3007420X2.5M B3007422X2M	M4007420M M4007420M M4007422M
25×2.5** 25×3	B3007425X2.5M B3007425X3M	M4007425M M4007425M
28×2 28×2.5	on request on request	
30×2 30×2.5 30×3**	on request B3007430X2.5M B3007430X3M	M4007430M M4007430M
32×3	B3007432X3M	M4007432M
38×4**	B3007438X4M	M4007438M
42×3	B3007442X3M	M4007442M

Inch tube

Tube size (O.D. × wall thickness) inch	Flare pin Order code	Flare die Order code
1/4×0.028 1/4×0.035 1/4×0.049	on request B3004X035074 B3004X049074	M4004074 M4004074
3/8×0.049 3/8×0.065	B3006X049074 B3006X065074	M4006074 M4006074
5/16×0.035 5/16×0.049 5/16×0.065	B3005X035074 B3005X049074 B3005X064074	M4007408M M4007408M M4007408M
1/2×0.065 1/2×0.083	B3008X065074 B3008X083074	M4008074 M4008074
5/8×0.065 5/8×0.083 5/8×0.095	on request B3010X083074 B3010X095074	M4010074 M4010074
3/4×0.095 3/4×0.109	B 3012X095074 B 3012X109074	M 4012074 M 4012074
1×0.083 1×0.095 1×0.109 1×0.120	B 3016X083074 B 3016X095074 B 3016X109074 B 3016X120074	M 4016074 M 4016074 M 4016074 M 4016074
1-1/4×0.095 1-1/4×0.120	B3020X095074 B3020X120074	M4020074 M4020074
1-1/2×0.120	B3024X120074	M4024074

Notes:

**These sizes are presently available for flaring stainless steel tubing (304 L and 316 L).
Use the suffix "SS" after the steel order code (e.g. B3007416X1.5MSS).



Parflange® tools for Flange Seal

Flange-seal tools are not suitable for O-Lok®



Clamping die set M ... 180



Parflange® pin B ... 180

Metric tube

Tube size (O.D. × wall thickness) mm	Flange pin Order code	Flange die Order code
6×1	B3018006X1M	M4018006X1MLHP
8×1 8×1.5	B3018008X1M B3018008X1.5M	M4018008X1MLHP M4018008X1.5MLHP
10×1 10×1.5 10×2	B3018010X1M B3018010X1.5M B3018010X2M	M4018010X1MLHP M4018010X1.5MLHP M4018010X2MLHP
12×1 12×1.5	B3018012X1M B3018012X1.5M	M4018012X1MLHP M4018012X1.5MLHP
16×2	B3018016X2M	M4018015X2MLHP
20×2.5	B3018020X2.5M	M4018020X2.5MLHP
25×2.5 25×3	B3018025X2.5M B3018025X3M	M4018025X2.5MLHP M4018025X3MLHP

Inch tube

Tube size (O.D. × wall thickness) mm	Flange pin Order code	Flange die Order code
1/4×0.035 1/4×0.049	B4004X035180 B4004X049180	M4004X035180LHP M4004X049180LHP
3/8×0.049 3/8×0.065	B4006X049180 B4006X065180	M4006X049180LHP M4006X065180LHP
1/2×0.049 1/2×0.065 1/2×0.083	B4008X049180 B4008X065180 B400810X083180	M4008X049180LHP M4008X065180LHP M4008X083180LHP
5/8×0.065	B401010X065180	M4010X065180LHP
5/8×0.083	B401010X083180	M4010X083180LHP
3/4×0.065 3/4×0.083	B4012X065180 B4012X083180	M4012X065180LHP M4012X083180LHP
1×0.095	B4016X095180	M4016X095180LHP

Lubricants

NIROMONT lubricant for fitting assembly

LUBSS/LUBCAN lubricant for flaring and forming tools

NIROMONT is a high-performance lubricant which has been especially developed for the assembly of bite-type fittings.

For best individual application, EO-Niromont is available in a small tin (paste) or plastic bottle (liquid).

LUBSS/LUBCAN is a special lubricant for flaring dies, Parflange® tools and EO2-FORM tooling. It allows high-quality tube forming without excessive tool wear.

1040 LUBSS is the standard Lubricant for the Parflange® machine automatic tool lubrication system.



NIROMONT

Features, advantages and benefits of NIROMONT lubricant:

1. **Highly effective** – Niromont dramatically reduces assembly effort. This helps to prevent fitting failure resulting from insufficient assembly.
2. **Cost saving** – Tools in assembly machines will last much longer, resulting in high-quality tube forming with excellent sealing surface.
3. **No cold welding** – Cold welding of stainless steel threads is impossible when EO-Niromont is properly applied.
4. **Liquid** – Penetrates even small gaps.
5. **Paste** – Stays in place for a while. Ideal for application on pre-assembly tools.
6. **Compatible** – NIROMONT and LUBSS/LUBCAN do not effect fitting surfaces or seal materials.



LUBSS



LUBCAN

Ordering

Type	Order code
NIROMONT Assembly lubricant paste (130 g)	EONIROMONTPASTX
NIROMONT Assembly lubricant liquid (250 cc)	EONIROMONTFLUCESSX
Forming tool lubricant can (100 cc)	1040LUBCAN
Forming tool lubricant refill (1 L)	1040LUBSS

Cutting and bending tools

AV 6/42 – Tube saw square

Provides a neat and quick method of cutting tube at right angles. The exact cut is achieved by hardened guides. We recommend using deeper-section sawblades that cut in both directions for best results. The AV 6/42 can be used in a vice or just be clamped onto the tube for cutting.

Specifications:

Tube. O.D.: 6–42 mm
Weight: approx. 0.7 kg

Type	Order code
Tube cutting tool	AV06/42KPLX
Spare hardened guides	AV06/4208X

Features, advantages and benefits of tube saw square:

1. **Square cut** – Exact tube preparation greatly reduces leakage caused by assembly failures.
2. **Contour clamping** – Tube is not distorted by clamping.
3. **No vice required** – For workshop application AV 6/42 can simply be clamped onto the tube without using a vice or other attachment.
4. **Replaceable guides** – Worn out guides can easily be replaced to maintain neat cutting result.
5. **Light** – At only 0.7 kg, the AV 6/42 should be carried in the toolbox of every hydraulic tube fitter.



Cutting and bending tools

BAV 6/12 – Combined tube bending and cutting tool

The BAV 6/12 is a workshop device for neat tube cutting and simple but exact bending of small dimension EO-tube. Relatively small bending radii can be achieved.

The exact cut is achieved with hardened guides and using sawblades which are notched on both sides. The BAV 6/12 can be used in a vice or just be clamped onto a workbench.

Specifications:

Tube. OD: 6–12 mm
Weight: approx. 2 kg

Type	Order code
Combined tube bending and cutting tool including 3 bending rolls for 6 to 12 mm tube and bending lever	BAV6/12KPLX
Spare Parts	
Spare hardened guide	BAV6/1206X
Bending roll 6/8 mm	BAV06/1209X
Bending roll 10 mm	BAV06/1210X
Bending roll 12 mm	BAV06/1211X
Bending pin	BAV06/1207X
lever complete	BAV06/1220KPLX

Bending dimensions in mm			
Rolls for tube O.D.	6/8	10	12
Bending radius	19/20	25	26



Features, advantages and benefits of combined tube bending and cutting tool:

- Bending and cutting** – The BAV 6/12 is a light multi-purpose tool for all small dimension tube assemblies.
- Square cut** – Exact tube preparation greatly reduces leakage caused by assembly failures.
- No vice required** – For workshop application BAV 6/12 can simply be clamped onto a workbench.
- Small bending radii** – Compact tube bends allow tight assemblies.
- Light** – At only 2 kg, the BAV 6/12 can be easily brought to the assembly site.
- Optimised bending roller contour** – Special shape of bending roller allows small bends without tube flattening.

In-Ex tube deburring tool 226

Material: Aluminum with hardened steel blades
Tube-O.D.: 4 to 42 mm
Weight: 0.12 kg

Type	Order code
Tube deburrer	226
Replacement blades	226 blades

Features, advantages and benefits of In-Ex tube deburring tool 226:

- Proper deburring** – Exact tube preparation greatly reduces leakage caused by assembly failures.
- Replaceable blades** – Worn out blades can easily be replaced to maintain neat deburring result.
- Light** – At only 0.12 kg, the In-Ex tube deburring tool should be carried in the toolbox of every hydraulic tube fitter.



Cutting and bending tools

BV 6/18 – Tube bending tool

The BV/6/18 is a flexible bending device for simple but exact bending of EO-tube up to 18 mm tube O.D. The high quality bending results are achieved by 6 interchangeable bending rollers.

The fixing roller can be individually adjusted to produce a precise bend transition.

Specifications:

Tube-O.D.: 6–18 mm

Weight: approx. 4 kg

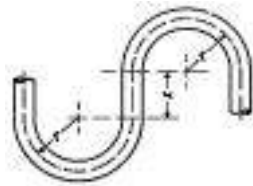

Type	Order code
Tube bending tool complete device including 6 bending rolls for 6 to 18 mm tube and bending lever	BV6/18KPLX
Spare Parts	
Bending roll 6/8 mm	BV06/1812X
Bending roll 10/12 mm	BV06/1803X
Bending roll 14 mm	BV06/1804X
Bending roll 15 mm	BV06/1805X
Bending roll 16 mm	BV06/1806X
Bending roll 18 mm	BV06/1807X
Fixing roll	BV06/1802X
Lever complete	BV06/1808KPLX

Rolls for tube O.D.	r	≈ X
6	33.0	35
8	34.0	35
10	35.5	35
12	36.5	35
14	36.5	35
15	44.0	38
16	44.0	38
18	51.5	42

Features, advantages and benefits of tube-bending tool:

- 1. Vice mounted** – For easy workshop use, the BV can be clamped into a vice.
- 2. Small bending radii** – Compact tube bends allow tight assemblies.
- 3. Light** – At only 4 kg, the BV 6/18 can be easily brought to each assembly site.
- 4. Optimised bending roller contour** – Special shape of bending roller allows small bends without tube flattening.

BV 20/25 – Tube bending tool

The BV 20/25 allows bending of medium size tube at the assembly site. The bending lever shows two universal studs. A bar extension can either be ordered or locally made.

Specifications:

Tube-O.D.: 20–25 mm
 3 bending segments: 20, 22, 25 mm
 Bending radius: $r = 86,5$ mm
 $x = 52$ mm
 Weight: approx. 15 kg (without bar extension)

Type	Order code
BV 20/25 Tube bending tool bending device including 3 bending segments for tube O.D. 20 to 25 mm including bending lever without bar extension tube	BV20/25KPLX
Spare Parts	
Bending segment 20 mm	BV20/2501X
Bending segment 22 mm	BV20/2502X
Bending segment 25 mm	BV20/2503X
Fixing arm	BV20/2505X
Lever complete	BV20/2506KPLX
Bar extension tube	BV20/2510X

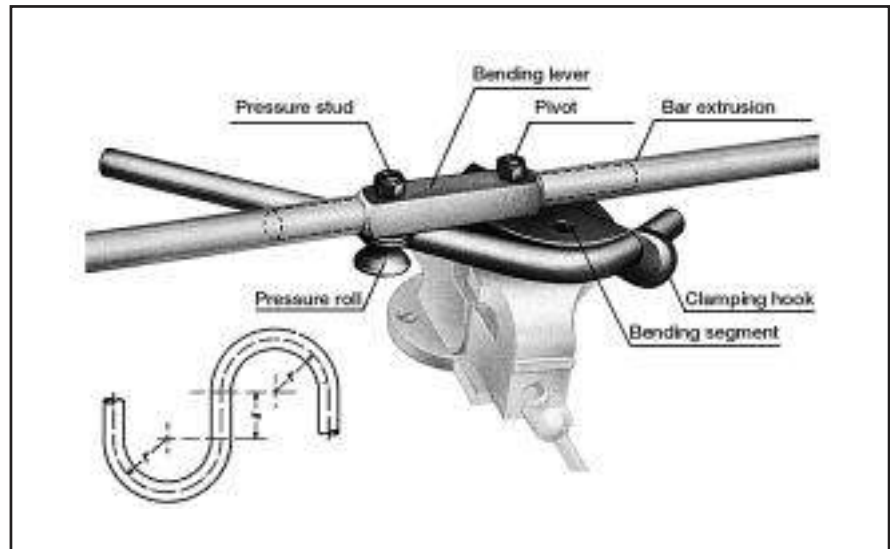

Features, advantages and benefits of tube-bending tool:

- Rigid design** – The solid design and the bar extension allow manual bending without heating the tube.
- Optimised bending roller contour** – Special shape of bending roller allows small bends without tube flattening.
- Shaped clamping** – Tube is not distorted by clamping.
- Small bending radii** – Compact tube bends allow for compact assemblies.
- Vice mounted** – For easy workshop use, the BV can be clamped into a vice.



Hand-tools

Par-Lok wrench

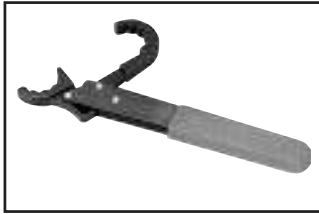

Par-Lok wrench

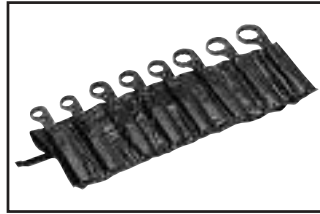

Par-Lok wrench kit



O-Lok® wrench kit



Triple-Lok® & Ferulok wrench kit

360° Snap-action ratchet wrench for hex sizes from 10 mm to 41 mm and inch sizes from 3/8" to 2 1/4" across flats. Inch sizes meet US government specifications and are listed as NSN-5120-00-474-7227.

Install tube fittings more quickly

Easy access ratchet wrench speeds fittings installation in tight locations. Rugged, snap-action jaws can be opened over tube lines, locked onto fitting hex and ratcheted within 1/8 turn. Full six point contact prevents fitting distortion common with wrench slippage. Ideal for tube line installations where compact runs required multiple fittings make-up, disassembly and remakes.

Specifications

Par-Lok wrenches are available individually or in different kit combinations. Par-Lok jaws are constructed from drop-forged, high carbon steel material with a black conversion coat finish. Par-Lok handles are made from heavy gauge steel material, heat treated and with a corrosion resistant black finish. Solid stainless steel rivets and tempered jaw springs are designed into every wrench for maximum strength.

O-Lok® wrench kit

Six piece wrench set for use with O-Lok® body and nut sizes -4, -6, -8. Kit contains wrenches for hex sizes 5/8", 1 1/16", 3/4", 13/16", 7/8" and 15/16".

Triple-Lok® & Ferulok wrench kit

Five piece wrench set for use with Triple-Lok® and Ferulok body and nut sizes -4, -6, -8, -10, -12. Kit contains wrenches for hex sizes 9/16", 11/16", 7/8", and 1" and 1 1/4".

Features, advantages and benefits

of Par-Lok wrench:

1. **360°** – No slipping and hexagon damage.
2. **Snap-mechanism** – Ideal for tube fitting assembly.
3. **Light** – Par-Lok wrenches belong in the standard toolbox of each fitting engineer.

Inch Sizes				Metric Sizes	
Hex Size	Order code	Hex Size	Order code	Hex Size	Order code
3/8	860062-6	1 1/8	860062-18	10 mm	860063-10
7/16	860062-7	1 1/4	860062-20	11 mm	860063-11
1/2	860062-8	1 3/8	860062-22	12 mm	860063-12
9/16	860062-9	1 1/2	860062-24	13 mm	860063-13
5/8	860062-10	1 5/8	860062-26	14 mm	860063-14
11/16	860062-11	1 7/8	860062-30	16 mm	860063-16
3/4	860062-12	2	860062-32	17 mm	860063-17
13/16	860062-13	2 1/4	860062-36	19 mm	860063-19
7/8	860062-14	Full kit of all	860062-KIT2	21 mm	860063-21
15/16	860062-15	eight wrenches		22 mm	860063-22
1	860062-16	O-Lok® kit	860062-LKIT	24 mm	860063-24
Full kit	860062-KIT	(six wrenches)		27 mm	860063-27
of all eleven sizes		Triple-Lok®/Ferulok kit	860062-UKIT	30 mm	860063-30
		(five wrenches)		32 mm	860063-32
				36 mm	860063-36
				41 mm	860063-41
				Full kit	860063-KIT
				of all ten sizes	
				10 to 22 mm	

WZK – Tool boxes

Tools which are regularly used for tube preparation and bending are available in organized tool boxes. Two sets are available:

Features, advantages and benefits:

1. **Well organised** – Nothing gets dirty, damaged, lost or forgotten.
2. **Practical** – In one box you take everything to the assembly site.
3. **Rigid** – The solid metal box is suitable for daily workshop use.

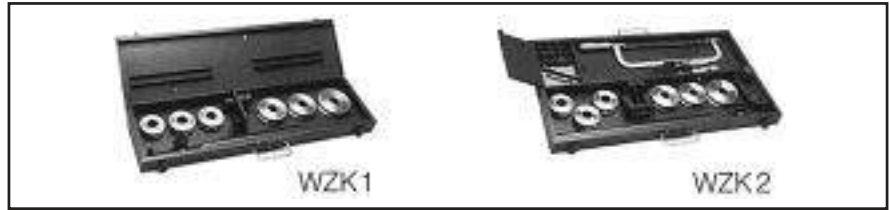

Type	Content	Order code
Toolbox WZK1	BV6/18 tube bending tool	WZK1KOMPLX
Toolbox WZK2	BV6/18 tube Bending tool, AV6/42 tube saw square, Hacksaw, Flat file, Deburring tool, fixture for assembly cones VOMO and cone gauge KONU	WZK2KOMPLX



O-ring assembly tools

CORG O-ring installation tool for O-Lok®

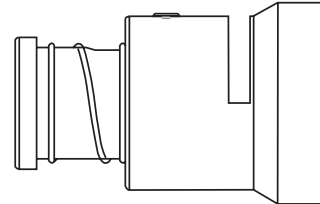

Parker's CORG Assembly Tools are designed to facilitate the installation of the O-ring into the half-dovetail groove of the O-ring face seal fitting. They are available in sizes –4 to –32 (6 mm to 50 mm/1/4" to 2" tube).

Ordering

CORG tool Order code	Fitting size	O-ring size
CORG-4	– 4	2-011
CORG-6	– 6	2-012
CORG-8	– 8	2-014
CORG-10	–10	2-016
CORG-12	–12	2-018
CORG-16	–16	2-021
CORG-20	–20	2-025
CORG-24	–24	2-029
CORG-32	–32	2-135

Operation

See chapter F “Fitting assembly” for detailed instructions

The CORG assembly tool is easy to use and can be operated in just a few steps:

1. Insert the O-ring into the slot located on the side of the tool.
2. Position the open end of the tool over the ORFS end of the fitting.
3. With the fitting end bottomed inside the tool, push the piston of the tool until the O-ring is released into the fitting groove.

O-ring pick for O-Lok®



O-ring pick

A plastic O-ring pick to allow easy removal of O-rings without causing damage to the fitting.

Ordering

Type	Order code
Plastic O-ring pick device	O-RINGPICK

Features, advantages and benefits of O-Ring installation tools

1. **Special** – O-ring installation tools are especially designed for O-Lok® fittings with CORG groove. O-rings are not torn or damaged at assembly.
2. **Cost saving** – O-ring installation tools are easy to use and save time and cost when O-rings need to be assembled.

Port cutting tools

Counterbore tools and thread taps for metric ports

For manufacturing metric ports to ISO 6149 (Details see chapter D).

These tools allow correct manufacturing of metric port connections. Counterbore tools and thread taps are made of high speed tool steel.

Ordering counterbore tools

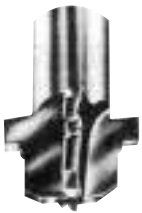

ISO 6149 Port size	Order code	
	Large Spot face	Small Spot face
M08 1	R1449A	R1449B
M10 1	R1450A	R1450B
M12 1.5	R1451A	R1451B
M14 1.5	R1452A	R1452B
M16 1.5	R1453A	R1453B
M18 1.5	R1454A	R1454B
M22 1.5	R1455A	R1455B
M27 2	R1456A	R1456B
M33 2	R1457A	R1457B
M42 2	R1458A	R1458B
M48 2	R1459A	R1459B

Ordering thread taps



Part thread ISO	Order code
M08	M08 1-GMTAP
M10	M10 1-GMTAP
M12	M12 1.5-GMTAP
M14	M14 1.5-GMTAP
M16	M16 1.5-GMTAP
M18	M18 1.5-GMTAP
M22	M22 1.5-GMTAP
M27	M27 2-GMTAP
M33	M33 2-GMTAP
M42	M42 2-GMTAP
M48	M48 2-GMTAP

Counterbore tools and thread taps for straight SAE thread ports

For manufacturing UNF ports to SAE J 1926-1 (details see chapter D)

These tools allow correct manufacturing of UNF port connections. Counterbore tools and thread taps are made of high speed tool steel.

counterbore tools

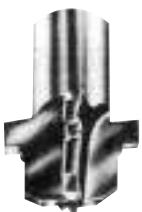

Use with UNF thread size	SAE dash size	Order code
5/16-24	2	Y-34730
3/8-24	3	Y-34731
7/16-20	4	Y-34732
1/2-20	5	Y-34733
9/16-18	6	Y-34734
3/4-16	8	Y-34735
7/8-14	10	Y-34736
1 1/16-12	12	Y-34737
1 3/16-12	14	Y-34738
1 5/16-12	16	Y-34739
1 5/8-12	29	Y-34740
1 7/8-12	24	Y-34741
2 1/2-12	32	Y-34743

thread taps



UNF thread size	SAE dash size	Order code
5/16-24	2	5/16X24 UNF-2B
3/8-24	3	3/8X24 UNF-2B
7/16-20	4	7/16X20 UNF-2B
1/2-20	5	1/2X20UNF-2B
9/16-18	6	9/16X18 UNF-2B
3/4-16	8	3/4X16 UNF-2B
7/8-14	10	7/8X14 UNF-2B
1 1/16-12	12	1 1/16X12 UNF-2B
1 3/16-12	14	1 3/16X12 UNF-2B
1 5/16-12	16	1 5/16X12 UNF-2B
1 5/8-12	29	1 5/8X12 UNF-2B
1 7/8-12	24	1 7/8X12 UNF-2B
2 1/2-12	32	2 1/2X12 UNF-2B

Operation of port cutting tools

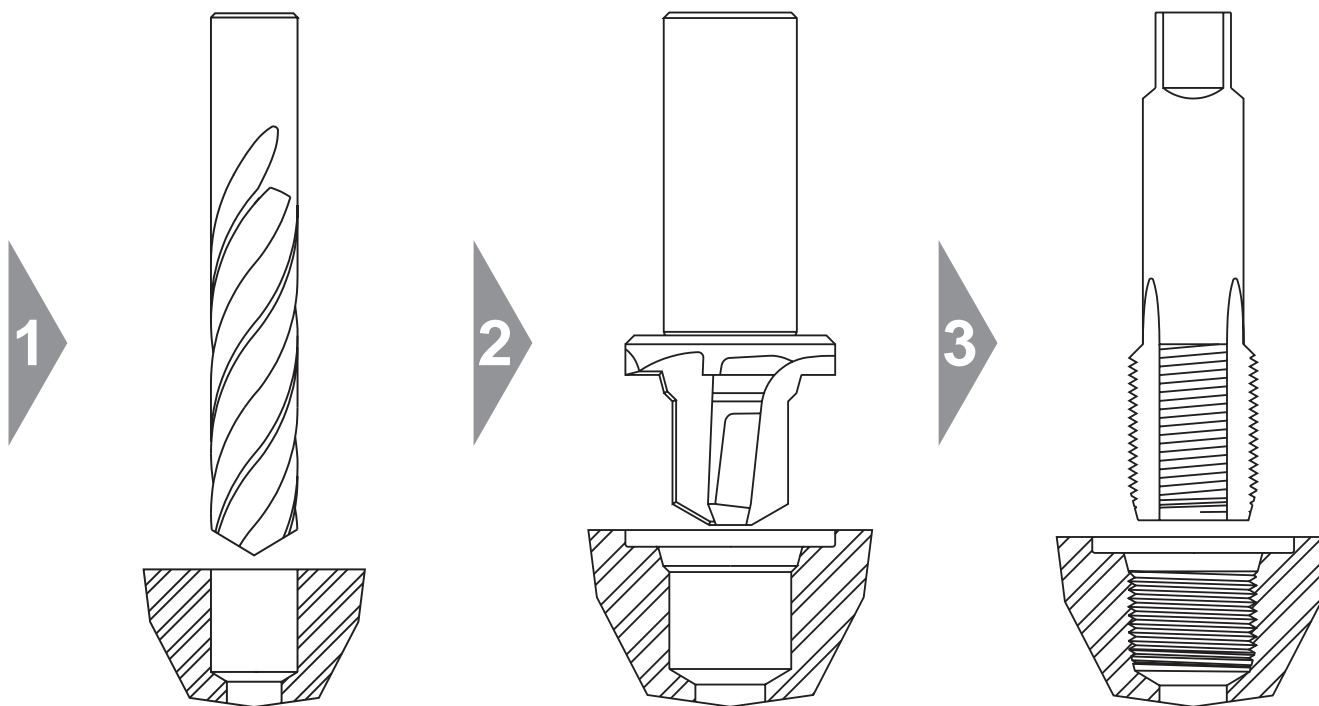

1. Pilot hole drilling

2. Port counterboring

3. Thread tapping

Note:

All dimensions must be according to relevant standards. See chapter D for details.

It is necessary to create a spotface surface which is flat and perpendicular to the port. Smooth finish to prevent leakage or O-ring extrusion.

Thread identification

Thread identification kit

The thread identification tools are beneficial in the assistance of the identification of international threads such as:

- European threads (Metric, BSPP, BSPT threads) and
- U.S. threads (NPT and SAE straight threads UNF)

The Thread Identification Kit is equipped with thread gauges, a set of callipers, thread profiles, and an instruction booklet.

The components of the thread ID Kit are no high precision gauges but simple instruments for workshop use.



Ordering

Type	Order code
Thread identification kit	MIK-1

Portboard

Portboards are suitable for thread identification of male stud connectors. The two portboards are machined with female threads for quick and easy identification by simply screwing the appropriate male port end.

- European (Metric, BSPP/BSPT threads)
- U.S. (NPT and SAE straight threads UNF)

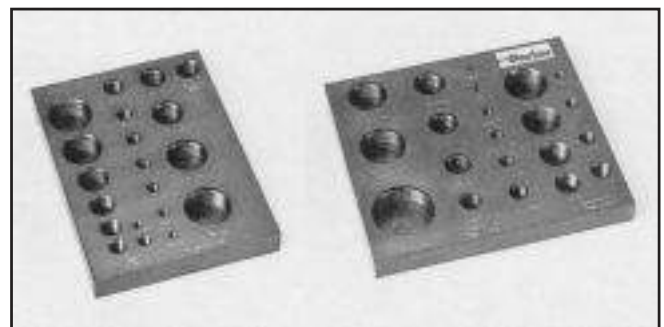

Ordering

Type	Order code
Portboard for NPT and SAE straight threads	Portboard A
Portboard for Metric and BSPP/BSPT threads	Portboard B

Training equipment

Sample case for assembly training

These practical cases are designed to support on-site assembly training. The rigid plastic boxes include sufficient nuts and rings or flare sleeves to do many hands-on assembly training. Properly cut and deburred tube-ends are also included so that functional fitting presentations, assembly machine demonstrations and proper in-depth assembly training are easy to conduct. An assortment of selected fitting bodies represent fittings like male stud ED-seal/O-Ring seal or adjustable elbows which need specific assembly procedures. For better overview and easy handling, the components are stored in individual plastic trays.

Two different sample cases are available for DIN (EO/EO2/EO2-FORM) and SAE (O-Lok®/Triple-Lok®) product training. Sample tube size is 16 2 mm, steel and stainless steel tube. These prepared tube pieces can be ordered separately for refill of the cases.

Specification

Case:	rigid plastic case with individual trays
Case dimension:	410 320 80 mm
Total weight:	approx. 10 kg
Tube size:	16 2 mm
Tube material:	steel and stainless steel

Ordering

Type		Order code
Sample case EO/EO2/EO2-FORM		DIN-CASE
Sample case O-Lok®/Triple-Lok®		SAE-CASE
Spare steel tube ends	10 pieces	R16X2X140VZ
Spare stainless steel tube ends	10 pieces	R16X2X14071

Case content

DIN CASE		SAE CASE	
Type	approx. qty	Type	approx. qty
Tube end components:		Tube end components:	
EO nuts/EO2 functional nuts FM	20	Triple-Lok®/O-Lok® nuts	20
PSR/DPR rings	50	Triple-Lok®/O-Lok® sleeves	50
EO2/EO2-FORM seal DOZ	50	Tube pieces (steel and stainless steel)	30
Tube pieces (steel and stainless steel)	30		
EO fitting bodies (steel):		Triple-Lok®/O-Lok® fitting bodies (steel):	
Tube to Tube unions	10	Tube to Tube unions	10
Male stud BSPP with ED-seal	5	Male stud BSPP with ED-seal	5
Male stud metric with O-ring	2	Male stud metric with O-ring	2
High pressure banjo	1	Male stud UNF with O-ring	2
Swivel nut elbow	1	Swivel nut elbow	2
Swivel union	1	Swivel union	2
Adjustable locknut elbow 90°/45°	1	Adjustable locknut elbow 90°/45°	2
Swivel reducer	1		
Distance piece adapter	1		



Please note:

Case content is continuously updated according to new product additions. Assembly tools are not included.

Features, advantages and benefits

- 1. Practical** – The cases and the content have been selected from experienced trainers for use with TFDE products.
- 2. Efficient** – The use of these case saves preparation time and effort.
- 3. Impressive** – Customers on workshop level will be impressed on the simple but professional training equipment.
- 4. Give-away samples** – Samples of the assemblies can stay at the customer. This will help to illustrate product function and demonstrate TFDE products.
- 5. Dry Technology** – As both, traditional and *Dry Technology* products are included, this case is a powerful and convincing sales tool particularly on workshop level.

Sample case for product presentation

This representative case is designed to support product presentations. The sample case includes cut-off samples of all TFDE tube fitting systems. Essential components like nuts and rings are added as individual samples.

The case looks representative and is of rigid design. All components are assorted in a black foam tray. The inside of the cover shows drawings of each product.

Specification

Case: rigid plastic case with foam tray
 Case dimension: 325 275 54 mm
 Total weight: approx. 1,8 kg
 Sample size: 16 2 mm
 Sample material: steel, stainless steel and brass

Ordering

Type	Order code
Showcase Tube fitting systems	SHOWCASESS

Case content

Cross sections (one piece each):	EO DPR/PSR, EO2, EO2-FORM, EO Weld Nipple, Triple-Lok®, O-Lok®
----------------------------------	--

Please note:

Case content is continuously updated according to new product additions.

Features, advantages and benefits

- 1. Essential sales tool** – The case is a powerful tool to illustrate the function and explain the components of each TFDE fitting system. It will contribute to visualize the features, advantages and benefits of the superior Parker products.
- 2. Practical** – The cases is light and easily can be brought to any customer visit. It also can be used at a distributors sales desk.
- 3. Efficient** – The use of these case saves preparation time and effort.
- 4. Impressive** – Customers on workshop level will be impressed on the simple but professional training equipment.
- 5. Durable** – As most components are made of stainless steel, the samples will stay bright and shiny even when they are used and touched regularly.
- 6. Dry Technology** – As both, traditional and *Dry Technology* products are included, this case is a powerful and convincing sales tool particularly on non-technician level.



Training aids

The “Leak-free Hydraulic Connectors” pocket book

The 226th volume in the series “The Technology Library”, entitled “Leak-free Hydraulic Connectors”, has been published by “Verlag Moderne Industrie”. It represents the most comprehensive treatment of high pressure connection technology presently available in the English language. Organised according to the fitting system, not only the latest developments in connecting and assembly technology but also national and international standards as well as market trends are clearly described. Each chapter is rounded off with detailed advice on practical application.



Specification

Title: Leak-free Hydraulic Connectors
Contents: Standards, operating principles and assembly for tube fittings
Author: Bernd Schmehl, Parker Hannifin, Ermeto Division
Publisher: Verlag Moderne Industrie, Landsberg/Lech 2002, Germany
This edition: 96 pages, 48 colour illustrations, hardback
ISBN-Nr: ISBN 3-478-93267-X

Ordering

Item	Ordering code
Single copy	TFDEBOOKUK
Sales display 20 copies	TFDEBOOKPACK20UK

Or:

Individual copies can be obtained from bookshops. A counter-top display unit containing 20 books is available to distributors.

Ordering code
TFDEBOOKPACK20UK

Features, advantages and benefits

- Up-to-date knowledge** – This pocket book is ideal for those who are new to this field and who want to find their way quickly and easily into the subject. But also for users whose professional training goes back over many years, this pocket book makes for interesting reading, containing as it does information on and evaluation of the latest product solutions and assembly technology.
- Practical** – The publication is intended not only as a reference book but also as something that can be read when travelling. It is ideally suited as a gift.
- Competitor-neutral** – To a large extent the contents lean more towards international standards and less to manufacturer-specific products. This pocket book is therefore ideal for use in teaching and in-house training and further education.
- Problemsolver** – Leakage problems occur frequently in hydraulic systems. The book helps to determine and eliminate the causes. For new projects, it can be consulted for the specification and planning of assembly work.



EO[®] Ermeto Original
DIN fittings



Visual index

Fitting components	<p>FM p. 18</p> <p>FORM p. 110</p> <p>M p. 112</p> <p>D p. 113</p> <p>PSR p. 113</p> <p>DPR p. 113</p>
	<p>S p. 114</p>
Tube to tube	<p>G p. 115</p> <p>GR p. 116</p> <p>W p. 117</p> <p>T p. 118</p> <p>TR p. 119</p> <p>K p. 121</p>
	<p>SV p. 122</p> <p>WSV p. 123</p>
Tube to swivel	<p>EW p. 124</p> <p>EV p. 125</p> <p>ET p. 126</p> <p>EL p. 127</p> <p>EVW p. 128</p> <p>EVT p. 129</p>
	<p>EVL p. 130</p> <p>DA p. 131</p> <p>RED p. 132</p> <p>KOR (Steel/Brass) p. 136</p> <p>KOR (Stainless steel) p. 140</p>
Swivel to swivel	<p>GZ p. 142</p> <p>GZR S.43</p>
Male stud connector	<p>GEO p. 145</p> <p>GE-M-ED p. 146</p> <p>GE-R-ED p. 147</p> <p>GE-R p. 149</p> <p>GE-R(KEG) p. 151</p> <p>GE-M p. 152</p>

Visual index

Male stud connector

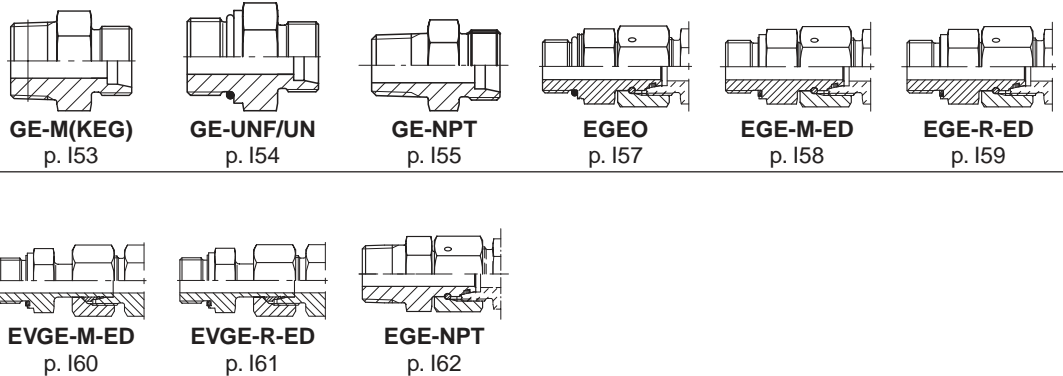

Swivel adjustable

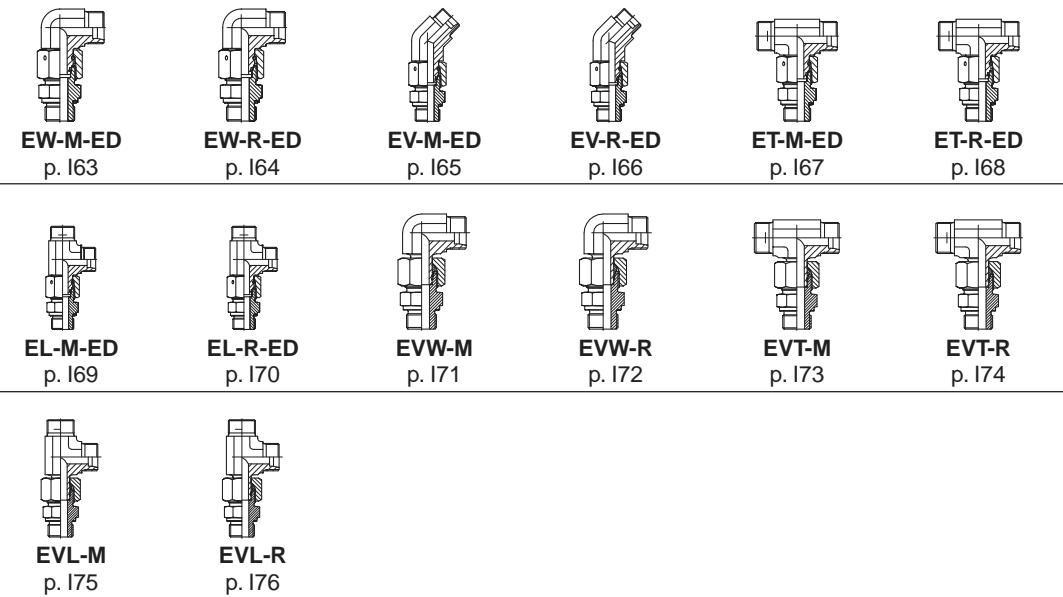

Locknut adjustable

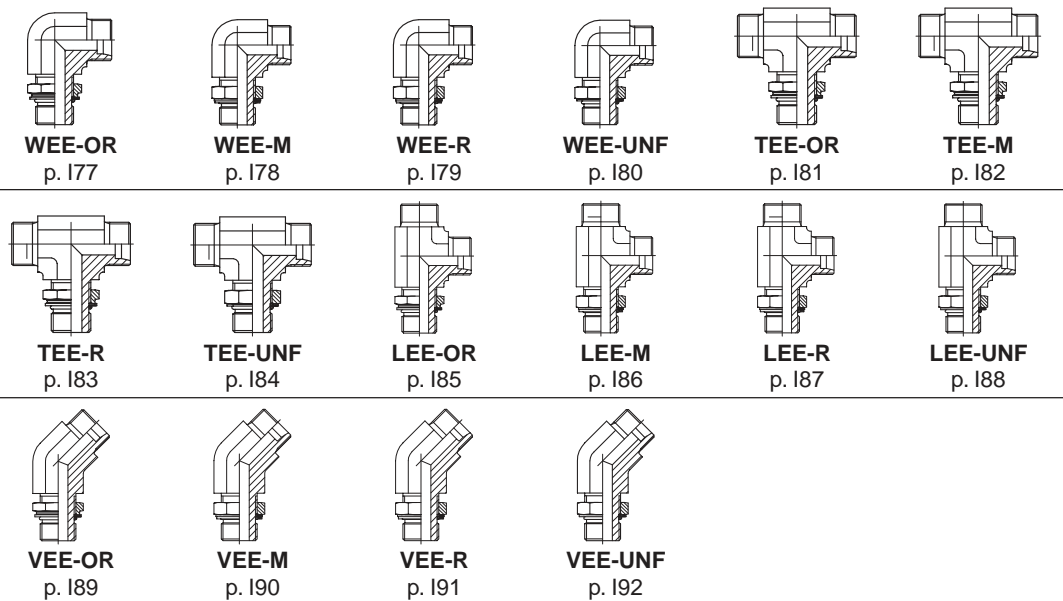

Visual index

Banjo fittings

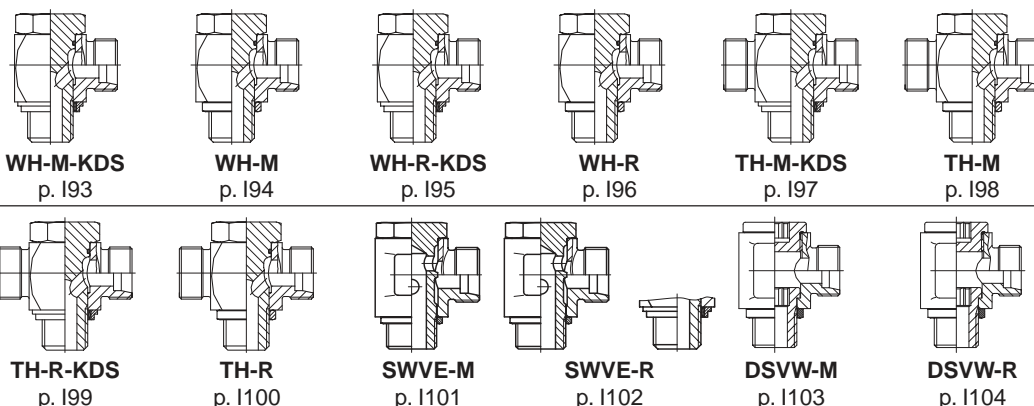

Non adjustable

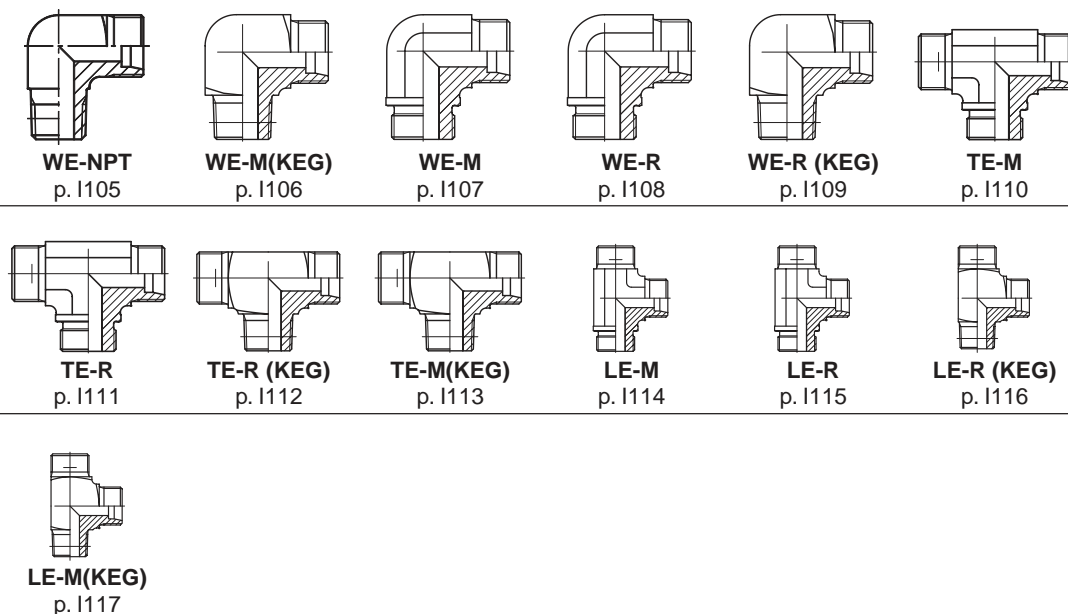

Tube to female

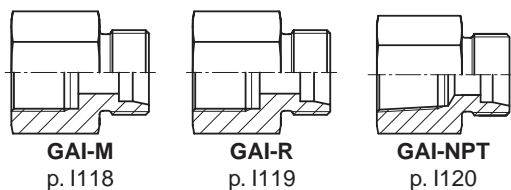

Port reducers

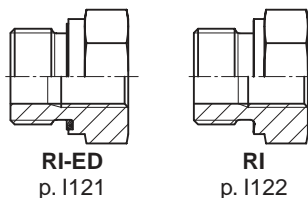

Pressure gauge adapter

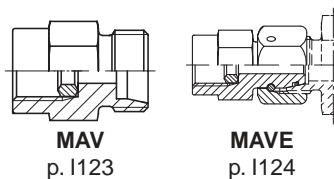

Visual index

Plugs

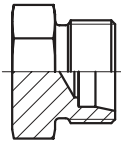

ROV
p. 1125

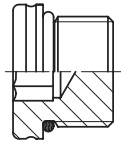

VSTI M-OR
p. 1126

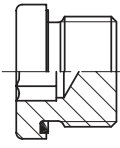

VSTI M/R-ED
p. 1127

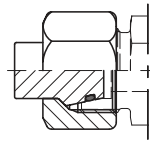

VKA
p. 1128

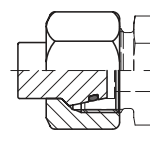

VKAM
p. 1129

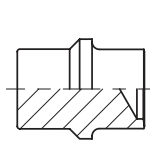

BUZ
p. 1130

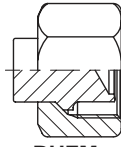

BUZM
p. 1131

Components



GM
p. 1132

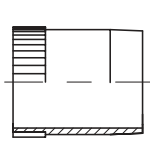

VH
p. 1133

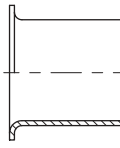

E
p. 1134



DOZ
p. 1135



ED
p. 1136

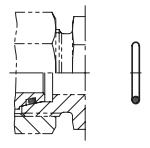

OR
p. 1137



DK1
p. 1140



KDS
p. 1141



KD
p. 1142



DKAZ
p. 1143



DKA
p. 1144

How to order

DIN fittings



GE-R-ED Male stud connector

Male BSPP thread – ED-seal (ISO 1179) / EO 24° cone end

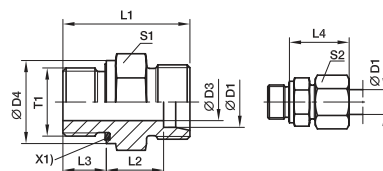

X1) Elastic-sealing ED

Series	D1	T1	D3	D4	L1	L2	L3	L4	S1	S2	Weight g/1 piece	Order code*	PN (bar) ¹⁾			
													CF	A3C	71	MS
S ²⁾	06	G1/4A	4	19	32,0	13,0	12	28	19	17	35	GE06SREDO MD	800	630	630	400
	06	G1/8A	4	14	27,5	12,5	8	27	14	17	21	GE06SR1/8ED OMD	315	315	315	
	06	G3/8A	4	22	34,5	15,5	12	30	22	17	52	GE06SR3/8ED OMD	630	630	630	
	06	G1/2A	4	27	39,0	18,0	14	33	27	17	83	GE06SR1/2ED OMD	630	630	630	
	08	G1/4A	5	19	34,0	15,0	12	30	19	19	41	GE08SREDO MD	800	630	630	400
	08	G3/8A	5	22	34,5	15,5	12	30	22	19	57	GE08SR3/8ED OMD	800	630	630	
	08	G1/2A	5	27	39,0	18,0	14	33	27	19	89	GE08SR1/2ED OMD	630	400	400	
	10	G3/8A	7	22	34,5	15,0	12	31	22	22	55	GE10SREDO MD	800	630	630	400
	10	G1/4A	5	19	34,0	14,5	12	31	19	22	42	GE10SR1/4ED OMD	800	630	630	
	10	G1/2A	7	27	39,0	17,5	14	34	27	22	97	GE10SR1/2ED OMD	630	630	630	
	12	G3/8A	8	22	36,5	17,0	12	33	22	24	62	GE12SREDO MD	630	630	630	400
	12	G1/4A	5	19	36,0	16,5	12	33	22	24	61	GE12SR1/4ED OMD	630	630	630	
	12	G1/2A	8	27	39,0	17,5	14	34	27	24	99	GE12SR1/2ED OMD	630	630	630	
	14	G1/2A	10	27	41,0	19,0	14	37	27	27	96	GE14SREDO MD	630	630	630	400
	14	G3/8A	8	22	38,5	18,5	12	36	24	27	74	GE14SR3/8ED OMD	630	630	630	
	14	G3/4A	10	32	45,0	21,0	16	39	32	27	138	GE14SR3/4ED OMD	400	400	400	
	16	G1/2A	12	27	41,0	18,5	14	37	27	30	91	GE16SREDO MD	630	400	400	250
	16	G3/8A	8	22	38,5	18,0	12	36	27	30	83	GE16SR3/8ED OMD	630	400	400	
	16	G3/4A	12	27	45,0	20,5	16	39	32	30	152	GE16SR3/4ED OMD	420	400	400	
	20	G3/4A	16	32	47,0	20,5	16	42	32	36	149	GE20SREDO MD	420	400	400	250
	20	G1/2A	12	27	45,0	20,5	14	42	32	36	142	GE20SR1/2ED OMD	420	400	400	
	20	G1A	16	40	51,0	22,5	18	44	41	36	265	GE20SR1ED OMD	420	400	400	
	20	G11/4A	16	50	53,0	22,5	20	44	50	36	404	GE20SR11/4ED OMD	420	400	400	
	25	G1A	20	40	53,0	23,0	18	47	41	46	266	GE25SREDO MD	420	400	400	250
	25	G1/2A	12	27	49,0	23,0	14	47	41	46	228	GE25SR1/2ED OMD	420	400	400	
	25	G3/4A	16	32	51,0	23,0	16	47	41	46	255	GE25SR3/4ED OMD	420	400	400	
	25	G11/4A	20	50	55,0	23,0	20	47	50	46	411	GE25SR11/4ED OMD	400	400	400	
	25	G11/2A	20	55	60,0	26,0	22	50	55	46	549	GE25SR11/2ED OMD	315	315	315	
	30	G11/4A	25	50	57,0	23,5	20	50	50	50	418	GE30SREDO MD	420	400	400	250
	30	G1A	20	40	55,0	23,5	18	50	46	50	344	GE30SR1ED OMD	420	400	400	
	30	G11/2A	25	55	62,0	26,5	22	53	55	50	530	GE30SR11/2ED OMD	315	315	315	
	38	G11/2A	32	55	64,0	26,0	22	57	55	60	563	GE38SREDO MD	420	315	315	400
	38	G11/4A	25	50	62,0	26,0	20	57	55	60	575	GE38SR11/4ED OMD	420	315	345	

¹⁾ Pressure shown = item deliverable

²⁾ S = heavy series

PN (bar) = PN (MPa) / 10

Delivery without nut and ring. Information on ordering complete fittings or alternative sealing materials see page 17.

*Ergänzen Sie bitte die Bestellzeichen mit den Kennbuchstaben für das gewünschte Material.

Order code suffixes			
Material	Suffix surface and material	Example	Standard sealing material (no additional suffix needed)
Steel, zinc plated, chrome ⁶⁾ -free	CF	GE16SREDO MDCF	NBR
Stahl, zinc yellow plated	A3C	GE16SREDO MDA3C	NBR
Stainless Steel	71	GE16SREDO MD71	VIT
Brass	MS	GE16SREDO MDMS	NBR

The right way to order made easy!

Step 1

Selecting order code

- 1.1 All fitting sizes available in our fitting program are clearly listed in the index at the front of this catalogue.
- 1.2 Open the catalogue at the corresponding page containing detailed information of the product of your choice.
- 1.3 Select the required fitting size! The basic order code is printed in bold type on the right-hand side of the table of dimensions.

Example: **GE16SREDO**MD

Step 2

Selecting material, surface and sealing-material

Now simply add the corresponding code for the surface and material variant of the product you require to the basic order code. This code is contained in the table printed at the bottom of every page.

2.1 Alternative sealing material

Example: chromium⁶⁾-free steel fitting with ED-seal in FKM material (e. g. Viton).
GE16SRED+OMD+VIT+CF = GE16SREDVITOMDCF

Example: Stainless steel fitting with ED-seal in NBR material (e. g. Perbunan).
GE16SREDO+MD+NBR+71 = GE16SREDNBROMD71

Step 3

When ordering fittings complete with nuts and rings

- 3.1. Metal sealed cutting rings PSR/DPR/D: For these types please delete the 'OMD' or 'X' suffixes.
 Example: **GE16SREDCF**
- 3.2. Soft sealed EO-2 functional nut: For these types please delete the 'OMD' or 'X' suffixes and add a 'Z' before the series suffix (LL, L, S)
 Example: **order with EO-2 functional nut**
GE16(+Z)SREDCF = GE16ZSREDCF

Viton = registered trademark of Bayer
 Perbunan = registered trademark of DuPont

The corresponding order variant is contained in the table printed at the bottom of every DIN chapter.

How to order EO-Fittings:

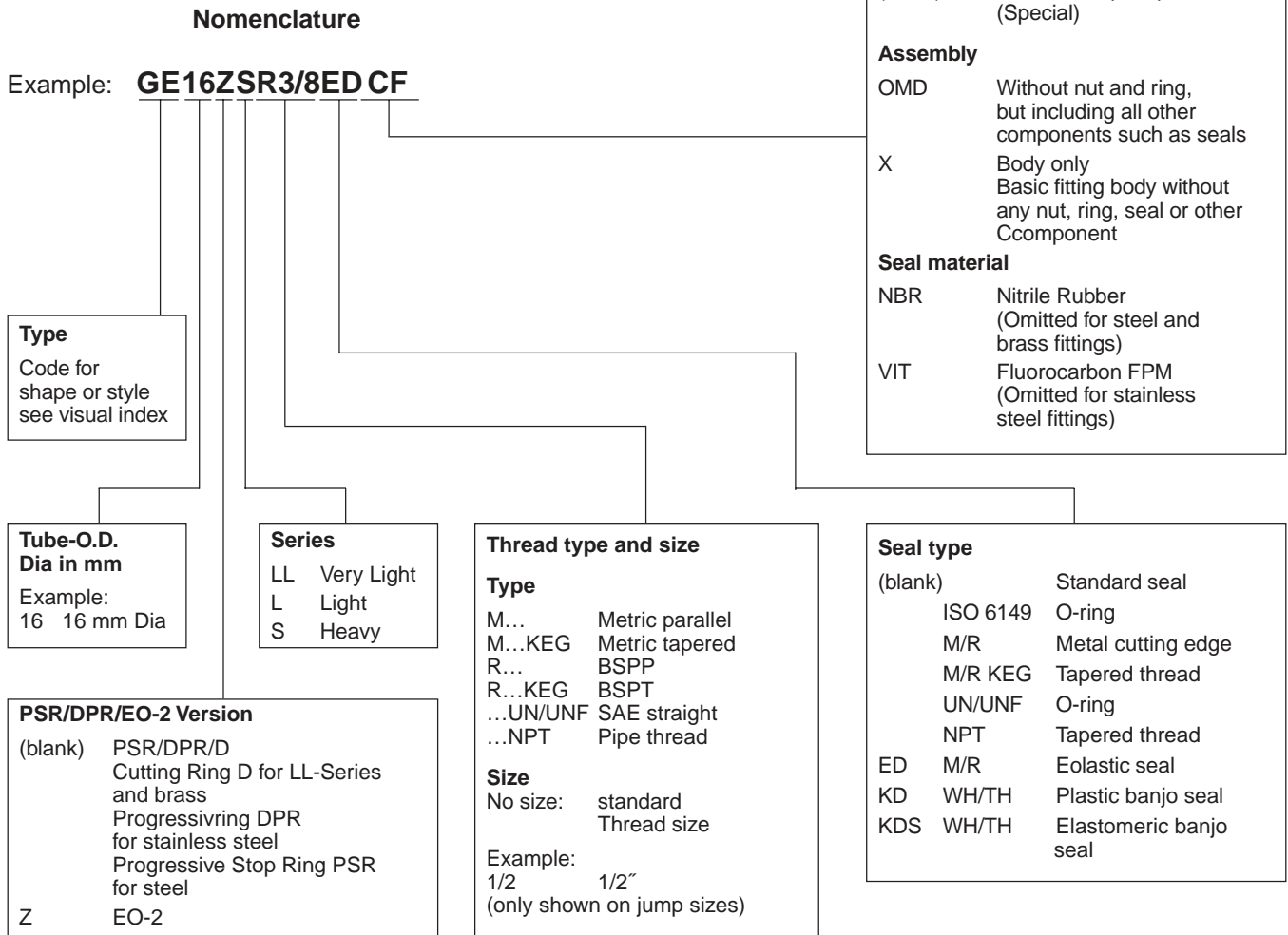

Examples			
Order code	Description	Order code	Description
GE12ZSR1/2EDCF	Straight male stud, EO-2, 20 mm tube O.D., heavy series, G 1/2 BSPP, Eolastic seal, complete with nut and ring, chromium ⁶ -free steel fitting, all seals NBR	EVT08LOMDMS	Adjustable standpipe branch tee, 8 mm tube O.D., light series, brass fitting without nut and ring, standpipe preassembled with nut and ring.
GE12LR71X	Straight male stud, 12 mm tube O.D., light series, G 3/8 BSPP, metal seal type B, stainless steel fitting, body only	EL38VITOMDA3C	Adjustable swivel nut run tee 38 mm tube O.D., heavy series, zinc-plated steel fitting without nut and ring. Swivel nut end with FKM seal
		DOZ04LL	Spare seal for EO-2 joints, 4 mm O.D., very light series, steel with nitrile rubber seal

FM EO2-Functional nut

for steel tubes

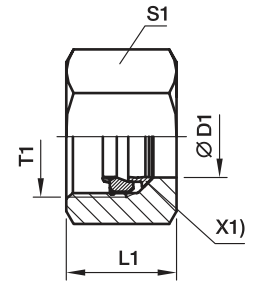

X1) Retaining ring

Series	D1	T1	L1	S1	Order code								Weight g/1 piece
					FM...CF Steel, zinc plated Cr6 free passiv. +Sealing		FM...VITCF Steel, zinc plated Cr6 free passiv. +Sealing		FM...A3C Steel, zinc yellow plated A3C		FM...VITA3C Steel, zinc yellow plated A3C		
					Sealing NBR	PN (bar)	Sealing FKM	PN (bar)	Sealing NBR	PN (bar)	Sealing FKM	PN (bar)	
LL	04	M8 1	11.0	10	—	—	—	—	FM04LLA3C	100	—	—	5
	06	M10 1	11.5	12	—	—	—	—	FM06LLA3C	100	—	—	6
L	06	M12 1.5	14.5	14	FM06LCF	500	FM06LVITCF	500	FM06LA3C	315	FM06LVITA3C	315	12
	08	M14 1.5	14.5	17	FM08LCF	500	FM08LVITCF	500	FM08LA3C	315	FM08LVITA3C	315	17
	10	M16 1.5	15.5	19	FM10LCF	500	FM10LVITCF	500	FM10LA3C	315	FM10LVITA3C	315	22
	12	M18 1.5	15.5	22	FM12LCF	400	FM12LVITCF	400	FM12LA3C	315	FM12LVITA3C	315	30
	15	M22 1.5	17.0	27	FM15LCF	400	FM15LVITCF	400	FM15LA3C	315	FM15LVITA3C	315	48
	18	M26 1.5	18.0	32	FM18LCF	400	FM18LVITCF	400	FM18LA3C	315	FM18LVITA3C	315	70
	22	M30 2	20.0	36	FM22LCF	250	FM22LVITCF	250	FM22LA3C	160	FM22LVITA3C	160	94
	28	M36 2	21.0	41	FM28LCF	250	FM28LVITCF	250	FM28LA3C	160	FM28LVITA3C	160	106
	35	M45 2	24.0	50	FM35LCF	250	FM35LVITCF	250	FM35LA3C	160	FM35LVITA3C	160	160
	42	M52 2	24.0	60	FM42LCF	250	FM42LVITCF	250	FM42LA3C	160	FM42LVITA3C	160	244
S	06	M14 1.5	16.5	17	FM06SCF	800	FM06SVITCF	800	FM06SA3C	630	FM06SVITA3C	630	20
	08	M16 1.5	16.5	19	FM08SCF	800	FM08SVITCF	800	FM08SA3C	630	FM08SVITA3C	630	23
	10	M18 1.5	17.5	22	FM10SCF	800	FM10SVITCF	800	FM10SA3C	630	FM10SVITA3C	630	37
	12	M20 1.5	17.5	24	FM12SCF	630	FM12SVITCF	630	FM12SA3C	630	FM12SVITA3C	630	39
	14	M22 1.5	20.5	27	FM14SCF	630	FM14SVITCF	630	FM14SA3C	630	FM14SVITA3C	630	60
	16	M24 1.5	20.5	30	FM16SCF	630	FM16SVITCF	630	FM16SA3C	400	FM16SVITA3C	400	72
	20	M30 2	24.0	36	FM20SCF	420	FM20SVITCF	420	FM20SA3C	400	FM20SVITA3C	400	121
	25	M36 2	27.0	46	FM25SCF	420	FM25SVITCF	420	FM25SA3C	400	FM25SVITA3C	400	221
	30	M42 2	29.0	50	FM30SCF	420	FM30SVITCF	420	FM30SA3C	400	FM30SVITA3C	400	248
	38	M52 2	32.5	60	FM38SCF	420	FM38SVITCF	420	FM38SA3C	315	FM38SVITA3C	315	367

$$\frac{\text{PN (bar)}}{10} = \text{PN (MPa)}$$

FM EO2-Functional nut

for stainless steel tubes

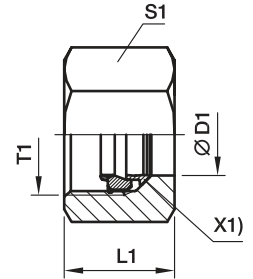

X1) Retaining ring

Series	D1	T1	L1	S1	Order code								Weight g/1 piece	
					FM...71 Stainless Steel		FM...NBR71 Stainless Steel		FM...SSA Steel, zinc plated Cr6 free passiv. +Sealing, Retaining ring: Stainless Steel		FM...VITSSA Steel, zinc plated Cr6 free passiv. +Sealing, Retaining ring: Stainless Steel			
					Sealing FKM	PN (bar)	Sealing NBR	PN (bar)	Sealing NBR	PN (bar)	Sealing FKM	PN (bar)		
LL	04	M8 1	11.0	10	—	—	—	—	FM04LLASSA	100	—	—	5	
	06	M10 1	11.5	12	—	—	—	—	FM06LLSSA	100	—	—	6	
L	06	M12 1.5	14.5	14	FM06L71	315	FM06LNBR71	315	FM06LSSA	315	FM06LVITSSA	315	12	
	08	M14 1.5	14.5	17	FM08L71	315	FM08LNBR71	315	FM08LSSA	315	FM08LVITSSA	315	17	
	10	M16 1.5	15.5	19	FM10L71	315	FM10LNBR71	315	FM10LSSA	315	FM10LVITSSA	315	22	
	12	M18 1.5	15.5	22	FM12L71	315	FM12LNBR71	315	FM12LSSA	315	FM12LVITSSA	315	30	
	15	M22 1.5	17.0	27	FM15L71	315	FM15LNBR71	315	FM15LSSA	315	FM15LVITSSA	315	48	
	18	M26 1.5	18.0	32	FM18L71	315	FM18LNBR71	315	FM18LSSA	315	FM18LVITSSA	315	70	
	22	M30 2	20.0	36	FM22L71	160	FM22LNBR71	160	FM22LSSA	160	FM22LVITSSA	160	94	
	28	M36 2	21.0	41	FM28L71	160	FM28LNBR71	160	FM28LSSA	160	FM28LVITSSA	160	106	
	35	M45 2	24.0	50	FM35L71	160	FM35LNBR71	160	FM35LSSA	160	FM35LVITSSA	160	160	
	42	M52 2	24.0	60	FM42L71	160	FM42LNBR71	160	FM42LSSA	160	FM42LVITSSA	160	244	
	S	06	M14 1.5	16.5	17	FM06S71	630	FM06SNBR71	630	FM06SSSA	630	FM06SVITSSA	630	20
		08	M16 1.5	16.5	19	FM08S71	630	FM08SNBR71	630	FM08SSSA	630	FM08SVITSSA	630	23
		10	M18 1.5	17.5	22	FM10S71	630	FM10SNBR71	630	FM10SSSA	630	FM10SVITSSA	630	37
		12	M20 1.5	17.5	24	FM12S71	630	FM12SNBR71	630	FM12SSSA	630	FM12SVITSSA	630	39
14		M22 1.5	20.5	27	FM14S71	630	FM14SNBR71	630	FM14SSSA	630	FM14SVITSSA	630	60	
16		M24 1.5	20.5	30	FM16S71	400	FM16SNBR71	400	FM16SSSA	400	FM16SVITSSA	400	72	
20		M30 2	24.0	36	FM20S71	400	FM20SNBR71	400	FM20SSSA	400	FM20SVITSSA	400	121	
25		M36 2	27.0	46	FM25S71	400	FM25SNBR71	400	FM25SSSA	400	FM25SVITSSA	400	221	
30		M42 2	29.0	50	FM30S71	400	FM30SNBR71	400	FM30SSSA	400	FM30SVITSSA	400	248	
38		M52 2	32.5	60	FM38S71	315	FM38SNBR71	315	FM38SSSA	315	FM38SVITSSA	315	367	

$$\frac{\text{PN (bar)}}{10} = \text{PN (MPa)}$$

EO2-FORM Functional Nut

for steel tubes

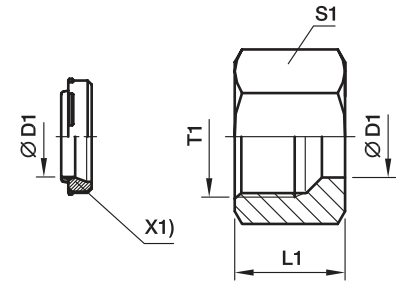

X1) Sealing (DOZ)

Series	D1	T1	L1	S1	Order code				Weight g/1 piece	
					FORM...CF Steel, zinc plated Cr6 free passiv. +Sealing	FORM...VITCF Steel, zinc plated Cr6 free passiv. +Sealing	FORM...A3C Steel, zinc yellow plated A3C	FORM...VITA3C Steel, zinc yellow plated A3C		Sealing NBR
L	06	M12 1.5	14.5	14	FORM06LCF	FORM06LVITCF	FORM06LA3C	FORM06LVITA3C	11	
	08	M14 1.5	14.5	17	FORM08LCF	FORM08LVITCF	FORM08LA3C	FORM08LVITA3C	16	
	10	M16 1.5	15.5	19	FORM10LCF	FORM10LVITCF	FORM10LA3C	FORM10LVITA3C	20	
	12	M18 1.5	15.5	22	FORM12LCF	FORM12LVITCF	FORM12LA3C	FORM12LVITA3C	27	
	15	M22 1.5	17.0	27	FORM15LCF	FORM15LVITCF	FORM15LA3C	FORM15LVITA3C	45	
	18	M26 1.5	18.0	32	FORM18LCF	FORM18LVITCF	FORM18LA3C	FORM18LVITA3C	67	
	22	M30 2	20.0	36	FORM22LCF	FORM22LVITCF	FORM22LA3C	FORM22LVITA3C	88	
	28	M36 2	21.0	41	FORM28LCF	FORM28LVITCF	FORM28LA3C	FORM28LVITA3C	99	
	35	M45 2	24.0	50	FORM35LCF	FORM35LVITCF	FORM35LA3C	FORM35LVITA3C	162	
	42	M52 2	24.0	60	FORM42LCF	FORM42LVITCF	FORM42LA3C	FORM42LVITA3C	233	
	S	06	M14 1.5	16.5	17	FORM06SCF	FORM06SVITCF	FORM06SA3C	FORM06SVITA3C	19
		08	M16 1.5	16.5	19	FORM08SCF	FORM08SVITCF	FORM08SA3C	FORM08SVITA3C	22
		10	M18 1.5	17.5	22	FORM10SCF	FORM10SVITCF	FORM10SA3C	FORM10SVITA3C	34
		12	M20 1.5	17.5	24	FORM12SCF	FORM12SVITCF	FORM12SA3C	FORM12SVITA3C	38
14		M22 1.5	20.5	27	FORM14SCF	FORM14SVITCF	FORM14SA3C	FORM14SVITA3C	57	
16		M24 1.5	20.5	30	FORM16SCF	FORM16SVITCF	FORM16SA3C	FORM16SVITA3C	71	
20		M30 2	24.0	36	FORM20SCF	FORM20SVITCF	FORM20SA3C	FORM20SVITA3C	115	
25		M36 2	27.0	46	FORM25SCF	FORM25SVITCF	FORM25SA3C	FORM25SVITA3C	216	
30		M42 2	29.0	50	FORM30SCF	FORM30SVITCF	FORM30SA3C	FORM30SVITA3C	242	
38		M52 2	32.5	60	FORM38SCF	FORM38SVITCF	FORM38SA3C	FORM38SVITA3C	366	

EO2-FORM Functional Nut

for stainless steel tubes

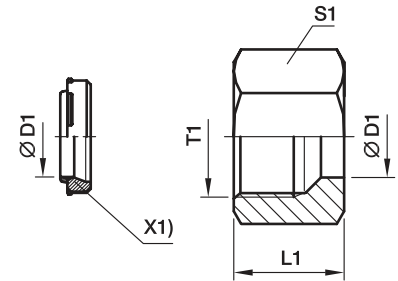

X1) Sealing (DOZ)

Series	D1	T1	L1	S1	Order code				Weight g/1 piece
					FORM...71 Stainless Steel Sealing FKM	FORM...NBR71 Stainless Steel Sealing NBR	FORM...CF Steel, zinc plated Cr6 free passiv. +Sealing Sealing NBR	FORM...VITCF Steel, zinc Cr6 free passiv. +Sealing Sealing FKM	
L	06	M12 1.5	14.5	14	FORM06L71	FORM06LNBR71	FORM06LCF	FORM06LVITCF	11
	08	M14 1.5	14.5	17	FORM08L71	FORM08LNBR71	FORM08LCF	FORM08LVITCF	16
	10	M16 1.5	15.5	19	FORM10L71	FORM10LNBR71	FORM10LCF	FORM10LVITCF	21
	12	M18 1.5	15.5	22	FORM12L71	FORM12LNBR71	FORM12LCF	FORM12LVITCF	27
	15	M22 1.5	17.0	27	FORM15L71	FORM15LNBR71	FORM15LCF	FORM15LVITCF	46
	18	M26 1.5	18.0	32	FORM18L71	FORM18LNBR71	FORM18LCF	FORM18LVITCF	68
	22	M30 2	20.0	36	FORM22L71	FORM22LNBR71	FORM22LCF	FORM22LVITCF	89
	28	M36 2	21.0	41	FORM28L71	FORM28LNBR71	FORM28LCF	FORM28LVITCF	101
	35	M45 2	24.0	50	FORM35L71	FORM35LNBR71	FORM35LCF	FORM35LVITCF	165
	42	M52 2	24.0	60	FORM42L71	FORM42LNBR71	FORM42LCF	FORM42LVITCF	237
S	06	M14 1.5	16.5	17	FORM06S71	FORM06SNBR71	FORM06SCF	FORM06SVITCF	19
	08	M16 1.5	16.5	19	FORM08S71	FORM08SNBR71	FORM08SCF	FORM08SVITCF	22
	10	M18 1.5	17.5	22	FORM10S71	FORM10SNBR71	FORM10SCF	FORM10SVITCF	35
	12	M20 1.5	17.5	24	FORM12S71	FORM12SNBR71	FORM12SCF	FORM12SVITCF	39
	14	M22 1.5	20.5	27	FORM14S71	FORM14SNBR71	FORM14SCF	FORM14SVITCF	58
	16	M24 1.5	20.5	30	FORM16S71	FORM16SNBR71	FORM16SCF	FORM16SVITCF	71
	20	M30 2	24.0	36	FORM20S71	FORM20SNBR71	FORM20SCF	FORM20SVITCF	117
	25	M36 2	27.0	46	FORM25S71	FORM25SNBR71	FORM25SCF	FORM25SVITCF	219
	30	M42 2	29.0	50	FORM30S71	FORM30SNBR71	FORM30SCF	FORM30SVITCF	246
	38	M52 2	32.5	60	FORM38S71	FORM38SNBR71	FORM38SCF	FORM38SVITCF	372

M Nut - EO 24° Cone end

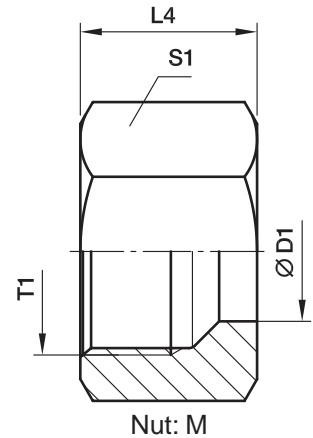

Series	D1	T1	L4	S1	Weight g/1 piece	Order code*	PN (bar) ¹⁾			
							CF	A3C	71	MS
LL ²⁾	04	M8 1	11.0	10	4	M04LL	100	100	100	63
	06	M10 1	11.5	12	6	M06LL	100	100	100	63
	08	M12 1	12.0	14	7	M08LL	100	100	100	63
	10	M14 1	12.5	17	11	M10LL	100	100	100	63
	12	M16 1	13.0	19	13	M12LL	100	100	100	63
L ³⁾	06	M12 1.5	14.5	14	10	M06L	500	315	315	200
	08	M14 1.5	14.5	17	15	M08L	500	315	315	200
	10	M16 1.5	15.5	19	18	M10L	500	315	315	200
	12	M18 1.5	15.5	22	25	M12L	400	315	315	200
	15	M22 1.5	17.0	27	42	M15L	400	315	315	200
	18	M26 1.5	18.0	32	62	M18L	400	315	315	200
	22	M30 2	20.0	36	82	M22L	250	160	160	100
	28	M36 2	21.0	41	89	M28L	250	160	160	100
	35	M45 2	24.0	50	137	M35L	250	160	160	100
	42	M52 2	24.0	60	216	M42L	250	160	160	100
S ⁴⁾	06	M14 1.5	16.5	17	17	M06S	800	630	630	400
	08	M16 1.5	16.5	19	20	M08S	800	630	630	400
	10	M18 1.5	17.5	22	31	M10S	800	630	630	400
	12	M20 1.5	17.5	24	34	M12S	630	630	630	400
	14	M22 1.5	20.5	27	53	M14S	630	630	630	400
	16	M24 1.5	20.5	30	66	M16S	630	400	400	250
	20	M30 2	24.0	36	102	M20S	420	400	400	250
	25	M36 2	27.0	46	202	M25S	420	400	400	250
	30	M42 2	29.0	50	219	M30S	420	400	400	250
	38	M52 2	32.5	60	339	M38S	420	315	315	200

¹⁾ Pressure shown = item deliverable

²⁾ LL = very light series; ³⁾ L = light series; ⁴⁾ S = heavy series

$$\frac{PN \text{ (bar)}}{10} = PN \text{ (MPa)}$$

*Please add the **suffixes** below according to the material/surface required.

Order code suffixes		
Material	Suffix surface and material	Example
Steel, zinc plated, chrome ⁶ -free	CFX	M16SCFX
Steel, zinc yellow plated	A3CX	M16SA3CX
Stainless Steel	71X	M16S71X
Brass	MSX	M16SMSX

PSR Progressive stop ring - DPR Progressive ring - D Cutting ring

for EO 24° cone end

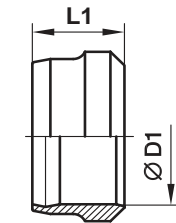
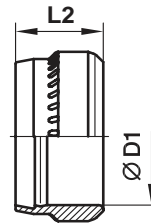
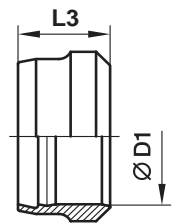

 Cutting ring:
D

 Progressive stop ring:
PSR

 Progressive ring:
DPR

Series	D1	Cutting ring D						Progressive stop ring PSR			Progressive ring DPR			Weight g/1 pc.			
		L1	Order code* Steel, zinc plated Cr6 free passiv.		Stainless Steel		Brass	PN (bar)	L2	Order code Steel, zinc plated Cr6 free passiv.		PN (bar)	L3		Order code Stainless Steel		PN (bar)
LL	04	6.0	D04LLX	100	D04LL71X	100	D04LLMSX	63	—	—	—	—	—	—	—	—	0.3
	06	7.0	D06LLX	100	D06LL71X	100	D06LLMSX	63	—	—	—	—	—	—	—	—	0.8
	08	7.0	D08LLX	100	D08LL71X	100	D08LLMSX	63	—	—	—	—	—	—	—	—	1.0
	10	7.0	D10LLX	100	D10LL71X	100	D10LLMSX	63	—	—	—	—	—	—	—	—	1.3
	12	7.5	D12LLX	100	D12LL71X	100	D12LLMSX	63	—	—	—	—	—	—	—	—	1.6
L	06	9.5	—	—	—	—	D06LMSX	200	9.5	PSR06LX	500	9.0	DPR06L71X	315	1.7		
	08	9.0	—	—	—	—	D08LMSX	200	9.5	PSR08LX	500	9.0	DPR08L71X	315	2.2		
	10	10.0	—	—	—	—	D10LMSX	200	10.0	PSR10LX	500	9.5	DPR10L71X	315	3.1		
	12	10.0	—	—	—	—	D12LMSX	200	10.0	PSR12LX	400	9.8	DPR12L71X	315	3.5		
	15	10.0	—	—	—	—	D15LMSX	200	10.0	PSR15LX	400	9.5	DPR15L71X	315	4.5		
	18	10.0	—	—	—	—	D18LMSX	200	10.0	PSR18LX	400	9.5	DPR18L71X	315	5.5		
	22	10.5	—	—	—	—	D22LMSX	100	10.5	PSR22LX	250	10.5	DPR22L71X	160	7.3		
	28	10.5	—	—	—	—	D28LMSX	100	10.5	PSR28LX	250	11.0	DPR28L71X	160	9.4		
	35	13.0	—	—	—	—	D35LMSX	100	13.0	PSR35LX	250	13.5	DPR35L71X	160	20.0		
	42	13.5	—	—	—	—	D42LMSX	100	13.0	PSR42LX	250	13.5	DPR42L71X	160	23.0		
S	06	9.5	—	—	—	—	D06SMSX	400	9.5	PSR06SX	800	9.0	DPR06S71X	630	1.7		
	08	9.0	—	—	—	—	D08SMSX	400	9.5	PSR08SX	800	9.0	DPR08S71X	630	3.2		
	10	10.0	—	—	—	—	D10SMSX	400	10.0	PSR10SX	800	9.5	DPR10S71X	630	3.1		
	12	10.0	—	—	—	—	D12SMSX	400	10.0	PSR12SX	630	9.8	DPR12S71X	630	3.5		
	14	10.0	—	—	—	—	D14SMSX	400	10.0	PSR14SX	630	9.5	DPR14S71X	630	3.9		
	16	10.5	—	—	—	—	D16SMSX	250	10.0	PSR16SX	630	9.5	DPR16S71X	400	5.6		
	20	12.5	—	—	—	—	D20SMSX	250	13.0	PSR20SX	420	12.5	DPR20S71X	400	11.4		
	25	12.5	—	—	—	—	D25SMSX	250	13.0	PSR25SX	420	12.5	DPR25S71X	400	13.3		
	30	13.0	—	—	—	—	D30SMSX	250	13.0	PSR30SX	420	12.5	DPR30S71X	400	19.3		
	38	13.5	—	—	—	—	D38SMSX	200	13.0	PSR38SX	420	13.0	DPR38S71X	315	22.5		

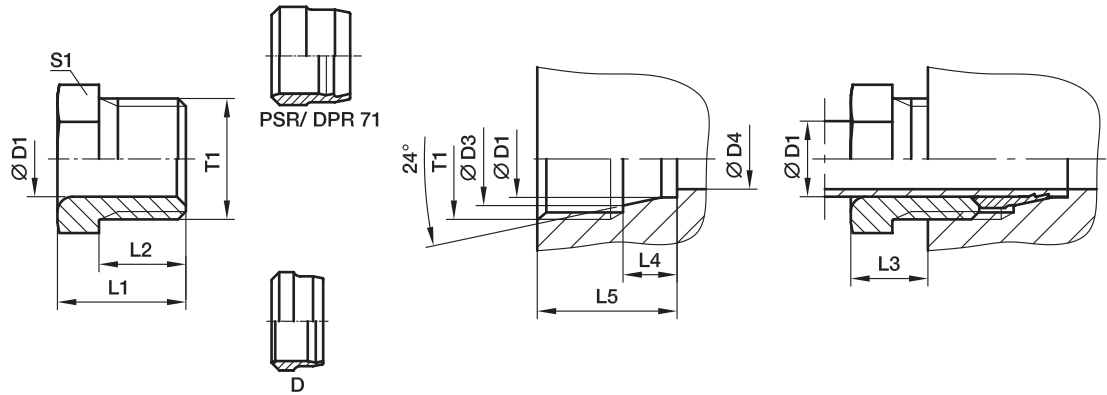
$$\frac{\text{PN (bar)}}{10} = \text{PN (MPa)}$$

S Sleeve screw

for thread holes according to DIN 3854



Series	D1 	T1	D3	D4	L1	L2	L3	L4	L5	S1	Weight g/1 piece	Order code*	PN (bar) ¹⁾		
													CF	A3C	71
LL ²⁾	04	M8 1	5.0	3.0	12	8.0	6	4.0	12.5	8	3	S04LL	100	100	100
	06	M10 1	7.5	4.5	13	9.0	7	5.5	14.5	10	4	S06LL	100	100	100
	08	M12 1	9.5	6.0	14	9.5	7	5.5	14.5	12	6	S08LL	100	100	100
L ³⁾	06	M12 1.5	8.1	4.0	16	11.5	10	7.0	18.5	12	9	S06L	315	315	315
	08	M14 1.5	10.1	6.0	16	11.5	10	7.0	18.5	14	11	S08L	315	315	315
	10	M16 1.5	12.3	8.0	17	11.5	10	7.0	18.5	17	15	S10L	315	315	315
	12	M18 1.5	14.3	10.0	18	12.0	10	7.0	19.0	19	19	S12L	315	315	315

¹⁾ Pressure shown = item deliverable

²⁾ LL = very light series; ³⁾ L = light series

$$\frac{\text{PN (bar)}}{10} = \text{PN (MPa)}$$

*Please add the **suffixes** below according to the material/surface required.

Order code suffixes		
Material	Suffix surface and material	Example
Steel, zinc plated, chrome ⁶ -free	CFX	S10LCFX
Steel, zinc yellow plated	A3CX	S10LA3CX
Stainless Steel	71X	S10L71X

G Union

EO 24° cone end

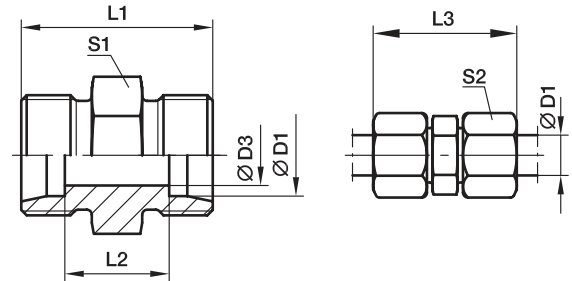

Series	D1	D3	L1	L2	L3	S1	S2	Weight g/1 piece	Order code*	PN (bar) ¹⁾			
										CF	A3C	71	MS
LL ²⁾	04	3.0	20	12	31	9	10	5	G04LL	100	100	100	63
	06	4.5	20	9	32	11	12	7	G06LL	100	100	100	63
	08	6.0	23	12	35	12	14	10	G08LL	100	100	100	63
	10	8.0	23	12	35	14	17	13	G10LL	100	100	100	63
	12	10.0	23	11	35	17	19	16	G12LL	100	100	100	63
L ³⁾	06	4.0	24	10	39	12	14	12	G06L	500	315	315	200
	08	6.0	25	11	40	14	17	16	G08L	500	315	315	200
	10	8.0	27	13	42	17	19	23	G10L	500	315	315	200
	12	10.0	28	14	43	19	22	28	G12L	400	315	315	200
	15	12.0	30	16	46	24	27	51	G15L	400	315	315	200
	18	15.0	31	16	48	27	32	69	G18L	400	315	315	200
	22	19.0	35	20	52	32	36	90	G22L	250	160	160	100
	28	24.0	36	21	54	41	41	137	G28L	250	160	160	100
	35	30.0	41	20	63	46	50	214	G35L	250	160	160	100
	42	36.0	43	21	66	55	60	296	G42L	250	160	160	100
S ⁴⁾	06	4.0	30	16	45	14	17	26	G06S	800	630	630	400
	08	5.0	32	18	47	17	19	37	G08S	800	630	630	400
	10	7.0	32	17	49	19	22	44	G10S	800	630	630	400
	12	8.0	34	19	51	22	24	60	G12S	630	630	630	400
	14	10.0	38	22	57	24	27	77	G14S	630	630	630	400
	16	12.0	38	21	57	27	30	90	G16S	630	400	400	250
	20	16.0	44	23	66	32	36	143	G20S	420	400	400	250
	25	20.0	50	26	74	41	46	251	G25S	420	400	400	250
	30	25.0	54	27	80	46	50	330	G30S	420	400	400	250
	38	32.0	61	29	90	55	60	545	G38S	420	315	315	200

¹⁾ Pressure shown = item deliverable

²⁾ LL = very light series; ³⁾ L = light series; ⁴⁾ S = heavy series

$$\frac{\text{PN (bar)}}{10} = \text{PN (MPa)}$$

Delivery without nut and ring. Information on ordering complete fittings see page I7.

*Please add the **suffixes** below according to the material/surface required.

Order code suffixes		
Material	Suffix surface and material	Example
Steel, zinc plated, chrome ⁶ -free	CFX	G16SCFX
Steel, zinc yellow plated	A3CX	G16SA3CX
Stainless Steel	71X	G16S71X
Brass	MSX	G16SMSX

GR Straight reducer

EO 24° cone end

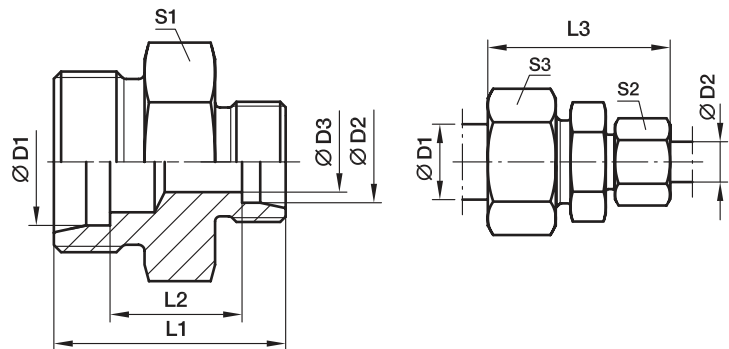

Series	D1	D2	D3	L1	L2	L3	S1	S2	S3	Weight g/1 piece	Order code*	PN (bar) ¹⁾			
												CF	A3C	71	MS
LL ²⁾	06	04	3.0	20	10.5	32	11	10	12	7	GR06/04LL	100	100	100	63
	08	04	3.0	22	12.5	34	12	10	14	9	GR08/04LL	100	100	100	63
	08	06	4.5	22	11.0	34	12	12	14	11	GR08/06LL	100	100	100	63
L ³⁾	08	06	4.0	25	11.0	40	14	14	17	16	GR08/06L	500	315	315	200
	10	06	4.0	26	12.0	41	17	14	19	21	GR10/06L	500	315	315	200
	10	08	6.0	26	12.0	41	17	17	19	21	GR10/08L	500	315	315	200
	12	06	4.0	27	13.0	42	19	14	22	26	GR12/06L	400	315	315	200
	12	08	6.0	27	13.0	42	19	17	22	26	GR12/08L	400	315	315	200
	12	10	8.0	28	14.0	43	19	19	22	29	GR12/10L	400	315	315	200
	15	10	8.0	29	15.0	45	24	19	27	46	GR15/10L	400	315	315	200
	15	12	10.0	29	15.0	45	24	22	27	45	GR15/12L	400	315	315	200
	18	10	8.0	30	15.5	46	27	19	32	65	GR18/10L	400	315	315	200
	18	12	10.0	30	15.5	46	27	22	32	64	GR18/12L	400	315	315	200
	18	15	12.0	31	16.5	48	27	27	32	65	GR18/15L	400	315	315	200
	22	12	10.0	32	17.5	48	32	22	36	80	GR22/12L	250	160	160	100
	22	15	12.0	33	18.5	50	32	27	36	89	GR22/15L	250	160	160	100
	22	18	15.0	33	18.0	50	32	32	36	89	GR22/18L	250	160	160	100
	28	18	15.0	34	19.0	52	41	32	41	142	GR28/18L	250	160	160	100
	28	22	19.0	36	21.0	54	41	36	41	139	GR28/22L	250	160	160	100
	35	22	19.0	39	21.0	59	46	36	50	202	GR35/22L	250	160	160	100
	35	28	24.0	39	21.0	59	46	41	50	206	GR35/28L	250	160	160	100
	42	35	30.0	43	21.5	66	55	50	60	330	GR42/35L	250	160	160	100
	S ⁴⁾	08	06	4.0	32	18.0	47	17	17	19	35	GR08/06S	800	630	630
10		06	4.0	32	17.5	48	19	17	22	41	GR10/06S	800	630	630	400
10		08	5.0	32	17.5	48	19	19	22	42	GR10/08S	800	630	630	400
12		06	4.0	34	19.5	50	22	17	24	56	GR12/06S	630	630	630	400
12		08	5.0	34	19.5	50	22	19	24	57	GR12/08S	630	630	630	400
12		10	7.0	34	19.0	51	22	22	24	59	GR12/10S	630	630	630	400
14		10	7.0	36	20.5	54	24	22	27	70	GR14/10S	630	630	630	400
14		12	8.0	36	20.5	54	24	24	27	72	GR14/12S	630	630	630	400
16		10	7.0	36	20.0	54	27	22	30	80	GR16/10S	630	400	400	250
16		12	8.0	36	20.0	54	27	24	30	87	GR16/12S	630	400	400	250
16		14	10.0	36	21.5	57	27	27	30	79	GR16/14S	630	400	400	250
20		10	7.0	40	22.0	60	32	22	36	129	GR20/10S	420	400	400	250
20		12	8.0	40	22.0	60	32	24	36	131	GR20/12S	420	400	400	250
20		16	12.0	42	23.0	63	32	30	36	134	GR20/16S	420	400	400	250
25		16	12.0	46	25.5	68	41	30	46	236	GR25/16S	420	400	400	250
25		20	16.0	48	25.5	71	41	36	46	235	GR25/20S	420	400	400	250
30		20	16.0	50	26.0	74	46	36	50	299	GR30/20S	420	400	400	250
30		25	20.0	52	26.5	77	46	46	50	317	GR30/25S	420	400	400	250
38		30	25	59	29.5	87	55	50	60	522	GR38/30S	420	315	315	200

¹⁾ Pressure shown = item deliverable

²⁾ LL = very light series; ³⁾ L = light series; ⁴⁾ S = heavy series

$$\frac{\text{PN (bar)}}{10} = \text{PN (MPa)}$$

Delivery without nut and ring. Information on ordering complete fittings see page I7.

*Please add the **suffixes** below according to the material/surface required.

Order code suffixes		
Material	Suffix surface and material	Example
Steel, zinc plated, chrome ⁶ -free	CFX	GR16/12SCFX
Steel, zinc yellow plated	A3CX	GR16/12SA3CX
Stainless Steel	71X	GR16/12S71X
Brass	MSX	GR16/12SMSX

W Union elbow

EO 24° cone end

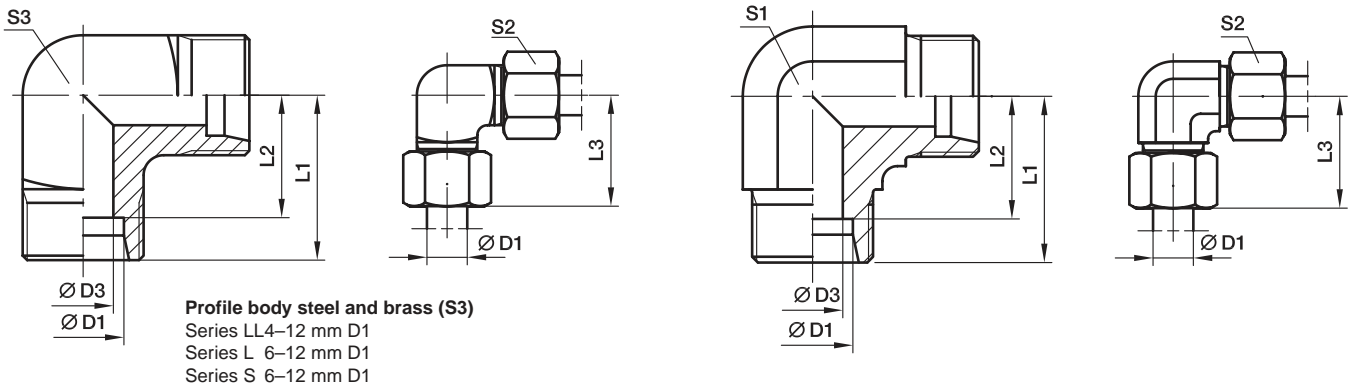

Series	D1	D3	L1	L2	L3	S1	S2	S3	Weight g/1 piece	Order code*	PN (bar) ¹⁾				
											CF	A3C	71	MS	
LL ²⁾	04	3.0	15	11.0	21	9	10	9	13	W04LL	100	100	100	63	
	06	4.5	15	9.5	21	9	12	11	15	W06LL	100	100	100	63	
	08	6.0	17	11.5	23	12	14	12	23	W08LL	100	100	100	63	
	10	8.0	18	12.5	24	12	17	14	32	W10LL	100	100	100	63	
	12	10.0	19	13.0	25	14	19	17	41	W12LL	100	100	100	63	
L ³⁾	06	4.0	19	12.0	27	12	14	12	29	W06L	500	315	315	200	
	08	6.0	21	14.0	29	12	17	14	43	W08L	500	315	315	200	
	10	8.0	22	15.0	30	14	19	17	54	W10L	500	315	315	200	
	12	10.0	24	17.0	32	17	22	19	80	W12L	400	315	315	200	
	15	12.0	28	21.0	36	19	27		81	W15L	400	315	315	200	
	18	15.0	31	23.5	40	24	32		140	W18L	400	315	315	200	
	22	19.0	35	27.5	44	27	36		178	W22L	250	160	160	100	
	28	24.0	38	30.5	47	36	41		340	W28L	250	160	160	100	
	35	30.0	45	34.5	56	41	50		458	W35L	250	160	160	100	
	42	36.0	51	40.0	63	50	60		776	W42L	250	160	160	100	
	S ⁴⁾	06	4.0	23	16.0	31	12	17	14	52	W06S	800	630	630	400
		08	5.0	24	17.0	32	14	19	17	74	W08S	800	630	630	400
10		7.0	25	17.5	34	17	22	19	97	W10S	800	630	630	400	
12		8.0	29	21.5	38	17	24	22	137	W12S	630	630	630	400	
14		10.0	30	22.0	40	19	27		145	W14S	630	630	630	400	
16		12.0	33	24.5	43	24	30		162	W16S	630	400	400	250	
20		16.0	37	26.5	48	27	36		221	W20S	420	400	400	250	
25		20.0	42	30.0	54	36	46		424	W25S	420	400	400	250	
30		25.0	49	35.5	62	41	50		603	W30S	420	400	400	250	
38		32.0	57	41.0	72	50	60		1010	W38S	420	315	315	200	

¹⁾ Pressure shown = item deliverable

²⁾ LL = very light series; ³⁾ L = light series; ⁴⁾ S = heavy series

$\frac{\text{PN (bar)}}{10} = \text{PN (MPa)}$

Delivery without nut and ring. Information on ordering complete fittings see page I7.

*Please add the **suffixes** below according to the material/surface required.

Order code suffixes		
Material	Suffix surface and material	Example
Steel, zinc plated, chrome ⁶ -free	CFX	W16SCFX
Steel, zinc yellow plated	A3CX	W16SA3CX
Stainless Steel	71X	W16S71X
Brass	MSX	W16SMSX

T Union tee

EO 24° cone end

profile body steel and brass (S3)

Series LL4-10 mm D1

Series L 6+ 8 mm D1

Series S 6 mm D1

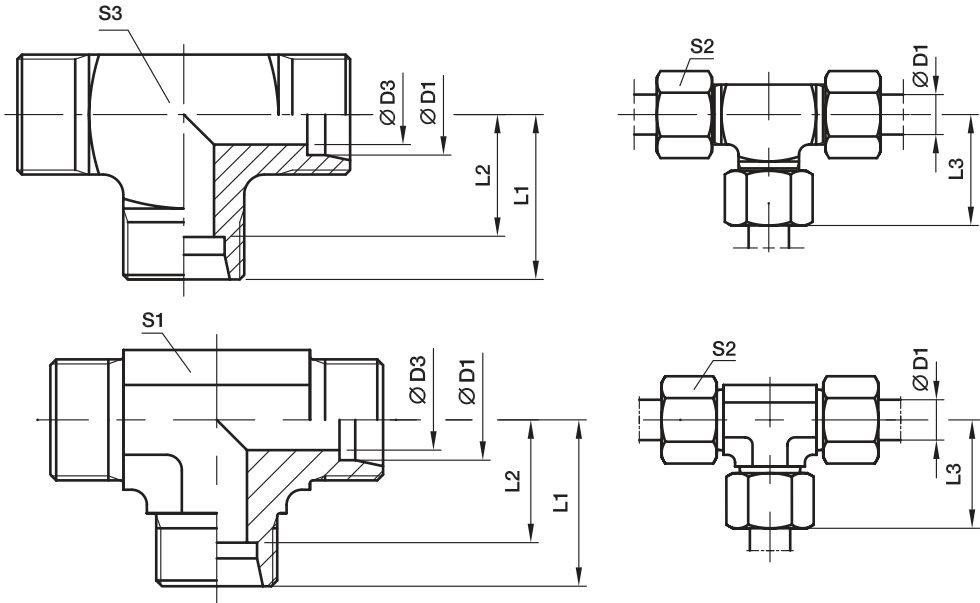

Series	D1	D3	L1	L2	L3	S1	S2	S3	Weight g/1 piece	Order code*	PN (bar) ¹⁾			
											CF	A3C	71	MS
LL ²⁾	04	3.0	15	11.0	21	9	10	9	19	T04LL	100	100	100	63
	06	4.5	15	9.5	21	9	12	11	20	T06LL	100	100	100	63
	08	6.0	17	11.5	23	12	14	12	27	T08LL	100	100	100	63
	10	8.0	18	12.5	24	12	17	14	39	T10LL	100	100	100	63
	12	10.0	21	15.0	27	14	19	19	45	T12LL	100	100	100	63
L ³⁾	06	4.0	19	12.0	27	12	14	12	37	T06L	500	315	315	200
	08	6.0	21	14.0	29	12	17	14	53	T08L	500	315	315	200
	10	8.0	22	15.0	30	14	19		48	T10L	500	315	315	200
	12	10.0	24	17.0	32	17	22		65	T12L	400	315	315	200
	15	12.0	28	21.0	36	19	27		106	T15L	400	315	315	200
	18	15.0	31	23.5	40	24	32		179	T18L	400	315	315	200
	22	19.0	35	27.5	44	27	36		225	T22L	250	160	160	100
	28	24.0	38	30.5	47	36	41		396	T28L	250	160	160	100
	35	30.0	45	34.5	56	41	50		567	T35L	250	160	160	100
	42	36.0	51	40.0	63	50	60		905	T42L	250	160	160	100
S ⁴⁾	06	4.0	23	16.0	31	12	17	14	68	T06S	800	630	630	400
	08	5.0	24	17.0	32	14	19		70	T08S	800	630	630	400
	10	7.0	25	17.5	34	17	22		91	T10S	800	630	630	400
	12	8.0	29	21.5	38	17	24		117	T12S	630	630	630	400
	14	10.0	30	22.0	40	19	27		136	T14S	630	630	630	400
	16	12.0	33	24.5	43	24	30		202	T16S	630	400	400	250
	20	16.0	37	26.5	48	27	36		289	T20S	420	400	400	250
	25	20.0	42	30.0	54	36	46		545	T25S	420	400	400	250
	30	25.0	49	35.5	62	41	50		758	T30S	420	400	400	250
	38	32.0	57	41.0	72	50	60		1264	T38S	420	315	315	200

¹⁾ Pressure shown = item deliverable

²⁾ LL = very light series; ³⁾ L = light series; ⁴⁾ S = heavy series

$$\frac{\text{PN (bar)}}{10} = \text{PN (MPa)}$$

Delivery without nut and ring. Information on ordering complete fittings see page 17.

*Please add the **suffixes** below according to the material/surface required.

Order code suffixes		
Material	Suffix surface and material	Example
Steel, zinc plated, chrome ⁶ -free	CFX	T16SCFX
Steel, zinc yellow plated	A3CX	T16SA3CX
Stainless Steel	71X	T16S71X
Brass	MSX	T16SMSX

TR Tee Reducer

EO 24° cone end

Profile body steel and brass (S1)
 Series LL 4-8 mm D1, D2, D3
 Series L 6+8 mm D1, D2, D3

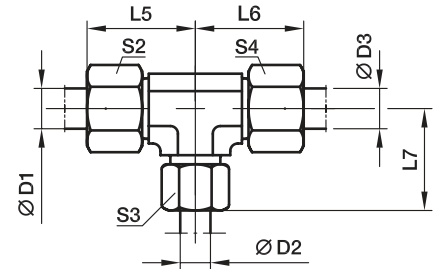
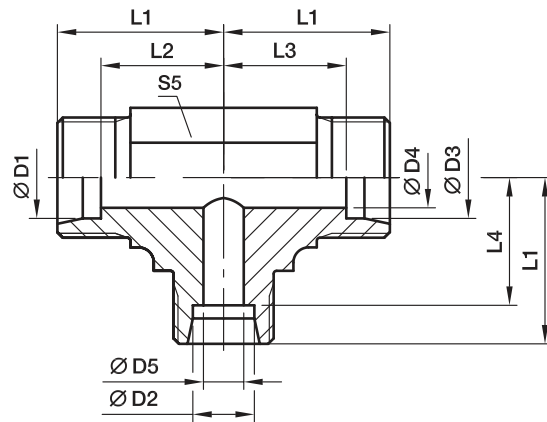
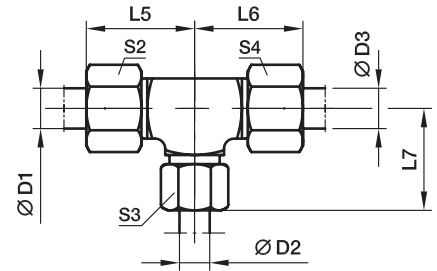
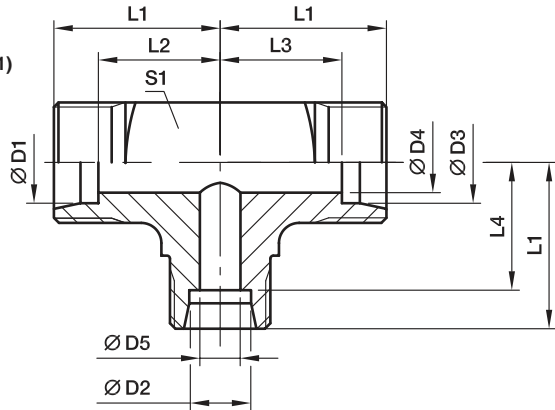

Series	D1, D2, D3			D4	D5	L1	L2	L3	L4	L5	L6	L7	S1	S2	S3	S4	S5	Weight g/1 piece	Order code*	PN (bar) ¹⁾			
	Ø	Ø	Ø																	CF	A3C	71	MS
LL ²⁾	04	08	04	3.0	6	17	13.0	13.0	11.5	23	23	23	12	10	14	10	12	27	TR04/08/04LL	100	100	100	63
	06	04	06	4.5	3	15	9.5	9.5	11.0	21	21	21	11	12	10	12	9	18	TR06/04/06LL	100	100	100	63
L ³⁾	06	08	06	4.0	6	21	14.0	14.0	14.0	29	29	29	14	14	17	14	12	54	TR06/08/06L	500	315	315	200
	08	06	08	6.0	4	21	14.0	14.0	14.0	29	29	29	14	17	14	17	12	53	TR08/06/08L	500	315	315	200
	06	10	06	4.0	8	22	15.0	15.0	15.0	30	30	30	14	14	19	14	14	53	TR06/10/06L	500	315	315	200
	08	10	08	6.0	8	22	15.0	15.0	15.0	30	30	30	17	19	17	14	14	50	TR08/10/08L	500	315	315	200
	10	06	10	8.0	4	22	15.0	15.0	15.0	30	30	30	19	14	19	14	14	46	TR10/06/10L	500	315	315	200
	10	08	10	8.0	6	22	15.0	15.0	15.0	30	30	30	19	17	19	14	14	43	TR10/08/10L	500	315	315	200
	10	10	06	4.0	8	22	15.0	15.0	15.0	30	30	30	19	19	14	14	14	49	TR10/10/06L	500	315	315	200
	08	12	08	6.0	10	24	17.0	17.0	17.0	32	32	32	17	22	17	17	17	67	TR08/12/08L	400	315	315	200
	12	06	12	10.0	4	24	17.0	17.0	17.0	32	32	32	22	14	22	17	17	66	TR12/06/12L	400	315	315	200
	12	08	08	6.0	6	24	17.0	17.0	17.0	32	32	32	22	17	17	17	17	66	TR12/08/08L	400	315	315	200
	12	08	12	10.0	6	24	17.0	17.0	17.0	32	32	32	22	17	22	17	17	68	TR12/08/12L	400	315	315	200
	12	10	10	8.0	8	24	17.0	17.0	17.0	32	32	32	22	19	19	17	17	67	TR12/10/10L	400	315	315	200
	12	10	12	10.0	8	24	17.0	17.0	17.0	32	32	32	22	19	22	17	17	67	TR12/10/12L	400	315	315	200
	12	12	10	8.0	10	24	17.0	17.0	17.0	32	32	32	22	22	19	17	17	64	TR12/12/10L	400	315	315	200
	10	15	10	8.0	12	28	21.0	21.0	21.0	36	36	36	19	27	19	19	19	105	TR10/15/10L	400	315	315	200
	12	15	12	10.0	12	28	21.0	21.0	21.0	36	36	36	22	27	22	19	19	102	TR12/15/12L	400	315	315	200
	15	06	15	12.0	4	28	21.0	21.0	21.0	36	36	36	27	14	27	19	19	107	TR15/06/15L	400	315	315	200
	15	10	15	12.0	8	28	21.0	21.0	21.0	36	36	36	27	19	27	19	19	105	TR15/10/15L	400	315	315	200
	15	12	12	10.0	10	28	21.0	21.0	21.0	36	36	36	27	22	22	19	19	101	TR15/12/12L	400	315	315	200
	15	12	15	12.0	10	28	21.0	21.0	21.0	36	36	36	27	22	27	19	19	105	TR15/12/15L	400	315	315	200
15	15	12	10.0	12	28	21.0	21.0	21.0	36	36	36	27	27	22	19	19	103	TR15/15/12L	400	315	315	200	
12	18	12	10.0	15	31	24.0	24.0	23.5	39	39	40	22	32	22	24	24	177	TR12/18/12L	400	315	315	200	
18	10	10	8.0	8	31	23.5	24.0	24.0	40	39	39	32	19	19	24	24	173	TR18/10/10L	400	315	315	200	
18	10	18	15.0	8	31	23.5	23.5	24.0	40	40	39	32	19	32	24	24	182	TR18/10/18L	400	315	315	200	
18	12	18	15.0	10	31	23.5	23.5	24.0	40	40	39	32	22	32	24	24	174	TR18/12/18L	400	315	315	200	

TR Tee Reducer

EO 24° cone end

Series	D1	D2	D3	D4	D5	L1	L2	L3	L4	L5	L6	L7	S1	S2	S3	S4	S5	Weight g/1 piece	Order code*	PN (bar) ¹⁾			
																				CF	A3C	71	MS
L ³⁾	18	15	18	15.0	12	31	23.5	23.5	24.0	40	40	39		32	27	32	24	179	TR18/15/18L	400	315	315	200
	18	18	10	8.0	15	31	23.5	24.0	23.5	40	39	40		32	32	19	24	171	TR18/18/10L	400	315	315	200
	22	10	22	19.0	8	35	27.5	27.5	28.0	44	44	43		36	19	36	27	232	TR22/10/22L	250	160	160	100
	22	12	22	19.0	10	35	27.5	27.5	28.0	44	44	43		36	22	36	27	229	TR22/12/22L	250	160	160	100
	22	15	15	12.0	12	35	27.5	28.0	28.0	44	43	43		36	27	27	27	240	TR22/15/15L	250	160	160	100
	22	15	22	19.0	12	35	27.5	27.5	28.0	44	44	43		36	27	36	27	233	TR22/15/22L	250	160	160	100
	22	18	18	15.0	15	35	27.5	27.5	27.5	44	44	44		36	32	32	27	236	TR22/18/18L	250	160	160	100
	22	18	22	19.0	15	35	27.5	27.5	27.5	44	44	44		36	32	36	27	239	TR22/18/22L	250	160	160	100
	22	22	18	15.0	19	35	27.5	27.5	27.5	44	44	44		36	36	32	27	228	TR22/22/18L	250	160	160	100
	28	10	28	24.0	8	38	30.5	30.5	31.0	47	47	46		41	19	41	36	412	TR28/10/28L	250	160	160	100
	28	12	28	24.0	10	38	30.5	30.5	31.0	47	47	46		41	22	41	36	408	TR28/12/28L	250	160	160	100
	28	15	28	24.0	12	38	30.5	30.5	31.0	47	47	46		41	27	41	36	423	TR28/15/28L	250	160	160	100
	28	18	28	24.0	15	38	30.5	30.5	30.5	47	47	47		41	32	41	36	421	TR28/18/28L	250	160	160	100
	28	22	22	19.0	19	38	30.5	30.5	30.5	47	47	47		41	36	36	36	412	TR28/22/22L	250	160	160	100
	28	22	28	24.0	19	38	30.5	30.5	30.5	47	47	47		41	36	41	36	415	TR28/22/28L	250	160	160	100
	S ⁴⁾	10	06	10	7.0	4	25	17.5	17.5	18.0	34	34	33		22	17	22	17	103	TR10/06/10S	800	630	630
12		08	08	5.0	5	29	21.5	22.0	22.0	38	37	37		24	19	19	17	107	TR12/08/08S	630	630	630	400
12		08	12	8.0	5	29	21.5	21.5	22.0	38	38	37		24	19	24	17	105	TR12/08/12S	630	630	630	400
12		10	12	8.0	7	29	21.5	21.5	21.5	38	38	38		24	22	24	17	114	TR12/10/12S	630	630	630	400
12		16	12	8.0	12	33	25.5	25.5	24.5	42	42	43		24	30	24	24	190	TR12/16/12S	630	400	400	250
16		06	16	12.0	4	33	24.5	24.5	26.0	43	43	41		30	17	30	24	176	TR16/06/16S	630	400	400	250
16		08	16	12.0	5	33	24.5	24.5	26.0	43	43	41		30	19	30	24	208	TR16/08/16S	630	400	400	250
16		10	16	12.0	7	33	24.5	24.5	25.5	43	43	42		30	22	30	24	210	TR16/10/16S	630	400	400	250
16		12	16	12.0	8	33	24.5	24.5	25.5	43	43	42		30	24	30	24	386	TR16/12/16S	630	400	400	250
16		20	16	12.0	16	37	28.5	28.5	26.5	47	47	48		30	36	30	27	296	TR16/20/16S	420	400	400	250
20		10	20	16.0	7	37	26.5	26.5	29.5	48	48	46		36	22	36	27	553	TR20/10/20S	420	400	400	250
20		12	20	16.0	8	37	26.5	26.5	29.5	48	48	46		36	24	36	27	306	TR20/12/20S	420	400	400	250
20		16	20	16.0	12	37	26.5	26.5	28.5	48	48	47		36	30	36	27	285	TR20/16/20S	420	400	400	250
20		25	20	16.0	20	42	31.5	31.5	30.0	53	53	54		36	46	36	36	544	TR20/25/20S	420	400	400	250
25		16	25	20.0	12	42	30.0	30.0	33.5	54	54	52		46	30	46	36	556	TR25/16/25S	420	400	400	250
25		20	25	20.0	16	42	30.0	30.0	31.5	54	54	53		46	36	46	36	544	TR25/20/25S	420	400	400	250
25	30	25	20.0	25	49	37.0	37.0	35.5	61	61	62		46	50	46	41	791	TR25/30/25S	420	400	400	250	

¹⁾ Pressure shown = item deliverable

²⁾ LL = very light series; ³⁾ L = light series; ⁴⁾ S = heavy series

$$\frac{\text{PN (bar)}}{10} = \text{PN (MPa)}$$

Delivery without nut and ring. Information on ordering complete fittings see page I7.

*Please add the **suffixes** below according to the material/surface required.

Order code suffixes		
Material	Suffix surface and material	Example
Steel, zinc plated, chrome ⁶ -free	CFX	TR16/12/16SCFX
Steel, zinc yellow plated	A3CX	TR16/12/16SA3CX
Stainless Steel	71X	TR16/12/16S71X
Brass	MSX	TR16/12/16SMSX

K Union cross

EO 24° cone end

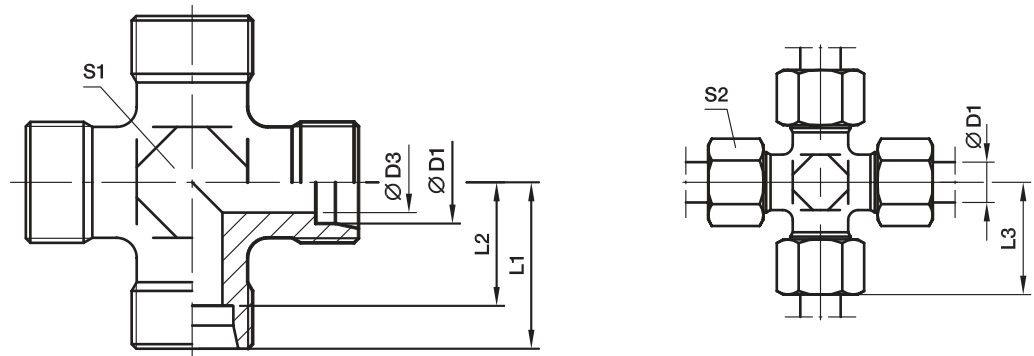

Series	D1	D3	L1	L2	L3	S1	S2	Weight g/1 piece	Order code*	PN (bar) ¹⁾			
										CF	A3C	71	MS
LL ²⁾	04	3.0	15	11.0	21	9	10	13	K04LL	100	100	100	63
	06	4.5	15	9.5	21	9	12	14	K06LL	100	100	100	63
	08	6.0	17	11.5	23	12	14	24	K08LL	100	100	100	63
L ³⁾	06	4.0	19	12.0	27	12	14	35	K06L	315	315	315	200
	08	6.0	21	14.0	29	12	17	40	K08L	315	315	315	200
	10	8.0	22	15.0	30	14	19	52	K10L	315	315	315	200
	12	10.0	24	17.0	32	17	22	69	K12L	315	315	315	200
	15	12.0	28	21.0	36	19	27	130	K15L	315	315	315	200
	18	15.0	31	23.5	40	24	32	188	K18L	315	315	315	200
	22	19.0	35	27.5	44	27	36	251	K22L	160	160	160	100
	28	24.0	38	30.5	47	36	41	392	K28L	160	160	160	100
	35	30.0	45	34.5	56	41	50	618	K35L	160	160	160	100
	42	36.0	51	40.0	63	50	60	905	K42L	160	160	160	100
S ⁴⁾	06	4.0	23	16.0	31	12	17	58	K06S	630	630	630	400
	08	5.0	24	17.0	32	14	19	82	K08S	630	630	630	400
	10	7.0	25	17.5	34	17	22	97	K10S	630	630	630	400
	12	8.0	29	21.5	38	17	24	146	K12S	630	630	630	400
	14	10.0	30	22.0	40	19	27	176	K14S	400	400	400	250
	16	12.0	33	24.5	43	24	30	220	K16S	400	400	400	250
	20	16.0	37	26.5	48	27	36	339	K20S	315	315	315	200
	25	20.0	42	30.0	54	36	46	576	K25S	315	315	315	200
	30	25.0	49	35.5	62	41	50	843	K30S	315	315	315	200
	38	32.0	57	41.0	72	50	60	1350	K38S	315	315	315	200

¹⁾ Pressure shown = item deliverable

²⁾ LL = very light series; ³⁾ L = light series; ⁴⁾ S = heavy series

$$\frac{\text{PN (bar)}}{10} = \text{PN (MPa)}$$

Delivery without nut and ring. Information on ordering complete fittings see page 17.

*Please add the **suffixes** below according to the material/surface required.

Order code suffixes		
Material	Suffix surface and material	Example
Steel, zinc plated, chrome ⁶ -free	CFX	K16SCFX
Steel, zinc yellow plated	A3CX	K16SA3CX
Stainless Steel	71X	K16S71X
Brass	MSX	K16SMSX

SV Bulkhead union

EO 24° cone end

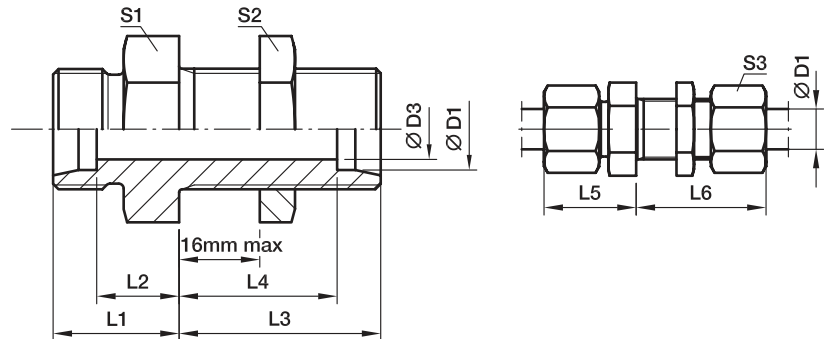

Series	D1	D3	L1	L2	L3	L4	L5	L6	S1	S2	S3	Weight g/1 piece	Order code*	PN (bar) ¹⁾			
														CF	A3C	71	MS
L ³⁾	06	4	14	7.0	34	27.0	22	42	17	17	14	39	SV06LOMD	500	315	315	200
	08	6	15	8.0	34	27.0	23	42	19	19	17	50	SV08LOMD	500	315	315	200
	10	8	17	10.0	35	28.0	25	43	22	22	19	67	SV10LOMD	500	315	315	200
	12	10	17	10.0	36	29.0	25	44	24	24	22	78	SV12LOMD	400	315	315	200
	15	12	19	12.0	38	31.0	27	46	27	30	27	128	SV15LOMD	400	315	315	200
	18	15	21	13.5	40	32.5	30	49	32	36	32	198	SV18LOMD	400	315	315	200
	22	19	24	16.5	42	34.5	33	51	36	41	36	254	SV22LOMD	250	160	160	100
	28	24	26	18.5	43	35.5	35	52	41	46	41	335	SV28LOMD	250	160	160	100
	35	30	29	18.5	47	36.5	40	58	50	55	50	546	SV35LOMD	250	160	160	
	42	36	30	19.0	47	36.0	42	59	60	65	60	758	SV42LOMD	250	160	160	
S ⁴⁾	06	4	19	12.0	36	29.0	27	44	19	19	17	65	SV06SOMD	800	630	630	400
	08	5	20	13.0	36	29.0	28	44	22	22	19	87	SV08SOMD	800	630	630	400
	10	7	22	14.5	37	29.5	31	46	24	24	22	112	SV10SOMD	800	630	630	400
	12	8	22	14.5	38	30.5	31	47	27	27	24	141	SV12SOMD	630	630	630	400
	14	10	25	17.0	40	32.0	35	50	30	30	27	180	SV14SOMD	630	630	630	
	16	12	25	16.5	40	31.5	35	50	32	32	30	201	SV16SOMD	630	400	400	250
	20	16	28	17.5	44	33.5	39	55	41	41	36	462	SV20SOMD	420	400	400	250
	25	20	32	20.0	47	35.0	44	59	46	46	46	492	SV25SOMD	420	400	400	250
	30	25	35	21.5	51	37.5	48	64	50	50	50	631	SV30SOMD	420	400	400	250
	38	32	38	22.0	53	37.0	53	68	65	65	60	1083	SV38SOMD	420	315	315	

¹⁾ Pressure shown = item deliverable

³⁾ L = light series; ⁴⁾ S = heavy series

$$\frac{\text{PN (bar)}}{10} = \text{PN (MPa)}$$

Delivery without nut and ring. Information on ordering complete fittings see page 17.

*Please add the **suffixes** below according to the material/surface required.

Order code suffixes		
Material	Suffix surface and material	Example
Steel, zinc plated, chrome ⁶ -free	CF	SV16SOMDCF
Steel, zinc yellow plated	A3C	SV16SOMDA3C
Stainless Steel	71	SV16SOMD71
Brass	MS	SV16SOMDMS

WSV Bulkhead elbow

EO 24° cone end

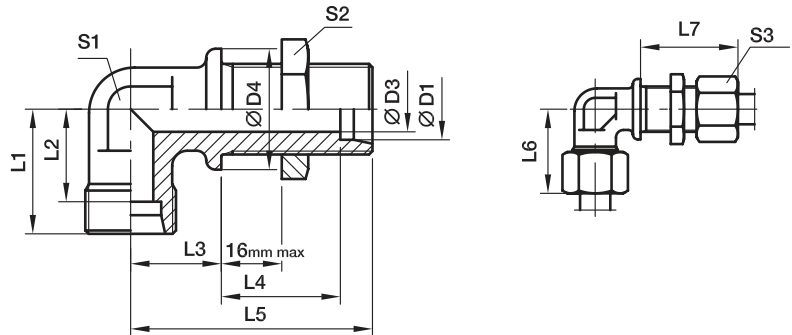

Series	D1	D3	D4	L1	L2	L3	L4	L5	L6	L7	S1	S2	S3	Weight g/1 piece	Order code*	PN (bar) ¹⁾			
																CF	A3C	71	MS
L ³⁾	06	4	17	19	12.0	14	27.0	48	27	42	12	17	14	51	WSV06LOMD	315	315	315	200
	08	6	19	21	14.0	17	27.0	51	29	42	12	19	17	61	WSV08LOMD	315	315	315	200
	10	8	22	22	15.0	18	28.0	53	30	43	14	22	19	78	WSV10LOMD	315	315	315	200
	12	10	24	24	17.0	20	29.0	56	32	44	17	24	22	85	WSV12LOMD	315	315	315	200
	15	12	27	28	21.0	23	31.0	61	36	46	19	30	27	150	WSV15LOMD	315	315	315	200
	18	15	32	31	23.5	24	32.5	64	40	49	24	36	32	238	WSV18LOMD	315	315	315	200
	22	19	36	35	27.5	30	34.5	72	44	51	27	41	36	327	WSV22LOMD	160	160	160	
	28	24	42	38	30.5	34	35.5	77	47	52	36	46	41	482	WSV28LOMD	160	160	160	
	35	30	50	45	34.5	39	36.5	86	56	58	41	55	50	729	WSV35LOMD	160	160	160	
	42	36	60	51	40.0	43	36.0	90	63	59	50	65	60	1091	WSV42LOMD	160	160	160	
S ⁴⁾	06	4	19	23	16.0	17	29.0	53	31	44	12	19	17	72	WSV06SOMD	630	630	630	
	08	5	22	24	17.0	18	29.0	54	32	44	14	22	19	99	WSV08SOMD	630	630	630	
	10	7	24	25	17.5	20	29.5	57	34	46	17	24	22	128	WSV10SOMD	630	630	630	
	12	8	27	29	21.5	21	30.5	59	38	47	17	27	24	168	WSV12SOMD	630	630	630	
	14	10	27	30	22.0	23	32.0	63	40	50	19	30	27	194	WSV14SOMD	630	630	630	
	16	12	30	33	24.5	24	31.5	64	43	50	24	32	30	249	WSV16SOMD	400	400	400	
	20	16	36	37	26.5	30	33.5	74	48	55	27	41	36	390	WSV20SOMD	400	400	400	
	25	20	42	42	30.0	34	35.0	81	54	59	36	46	46	618	WSV25SOMD	400	400	400	
	30	25	50	49	35.5	39	37.5	90	62	64	41	50	50	889	WSV30SOMD	400	400	400	
	38	32	60	57	41.0	43	37.0	96	72	68	50	65	60	1337	WSV38SOMD	315	315	315	

¹⁾ Pressure shown = item deliverable

³⁾ L = light series; ⁴⁾ S = heavy series

$\frac{PN \text{ (bar)}}{10} = PN \text{ (MPa)}$

Delivery without nut and ring. Information on ordering complete fittings see page 17.

*Please add the **suffixes** below according to the material/surface required.

Order code suffixes		
Material	Suffix surface and material	Example
Steel, zinc plated, chrome ⁶ -free	CF	WSV16SOMDCF
Steel, zinc yellow plated	A3C	WSV16SOMDA3C
Stainless Steel	71	WSV16SOMD71
Brass	MS	WSV18LOMDMS

EW Swivel nut elbow

EO 24° cone end / EO 24° DKO swivel

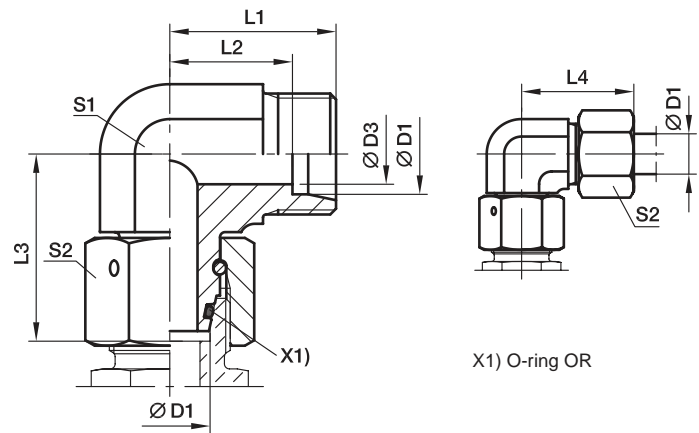

X1) O-ring OR

Series	D1	D3	L1	L2	L3	L4	S1	S2	Weight g/1 piece	Order code*	PN (bar) ¹⁾		
											CF	A3C	71
L ³⁾	06	4	19	12.0	26.0	27	12	14	34	EW06LOMD	500	315	315
	08	6	21	14.0	27.5	29	12	17	43	EW08LOMD	500	315	315
	10	8	22	15.0	29.0	30	14	19	58	EW10LOMD	500	315	315
	12	10	24	17.0	29.5	32	17	22	81	EW12LOMD	400	315	315
	15	12	28	21.0	32.5	36	19	27	128	EW15LOMD	400	315	315
	18	15	31	23.5	35.5	40	24	32	197	EW18LOMD	400	315	315
	22	19	35	27.5	38.5	44	27	36	258	EW22LOMD	250	160	160
	28	24	38	30.5	41.5	47	36	41	370	EW28LOMD	250	160	160
	35	30	45	34.5	51.0	56	41	50	593	EW35LOMD	250	160	160
	42	36	51	40.0	56.0	63	50	60	993	EW42LOMD	250	160	160
S ⁴⁾	06	4	23	16.0	27.0	31	12	17	48	EW06SOMD	800	630	630
	08	5	24	17.0	27.5	32	14	19	65	EW08SOMD	800	630	630
	10	6	25	17.5	30.0	34	17	22	92	EW10SOMD	800	630	630
	12	8	29	21.5	31.0	38	17	24	107	EW12SOMD	630	630	630
	14	9	30	22.0	35.0	40	19	27	146	EW14SOMD	630	630	630
	16	12	33	24.5	36.5	43	24	30	212	EW16SOMD	630	400	400
	20	16	37	26.5	44.5	48	27	36	309	EW20SOMD	420	400	400
	25	20	42	30.0	50.0	54	36	46	547	EW25SOMD	420	400	400
	30	25	49	35.5	55.0	62	41	50	744	EW30SOMD	420	400	400
	38	32	57	41.0	63.0	72	50	60	1222	EW38SOMD	420	315	315

¹⁾ Pressure shown = item deliverable

³⁾ L = light series; ⁴⁾ S = heavy series

$$\frac{\text{PN (bar)}}{10} = \text{PN (MPa)}$$

Delivery without nut and ring. Information on ordering complete fittings or alternative sealing materials see page I7.

*Please add the **suffixes** below according to the material/surface required.

Order code suffixes			
Material	Suffix surface and material	Example	Standard sealing material (no additional suffix needed)
Steel, zinc plated, chrome ⁶ -free	CF	EW16SOMDCF	NBR
Steel, zinc yellow plated	A3C	EW16SOMDA3C	NBR
Stainless Steel	71	EW16SOMD71	VIT

EV Swivel nut 45° elbow

EO 24° cone end / EO 24° DKO swivel

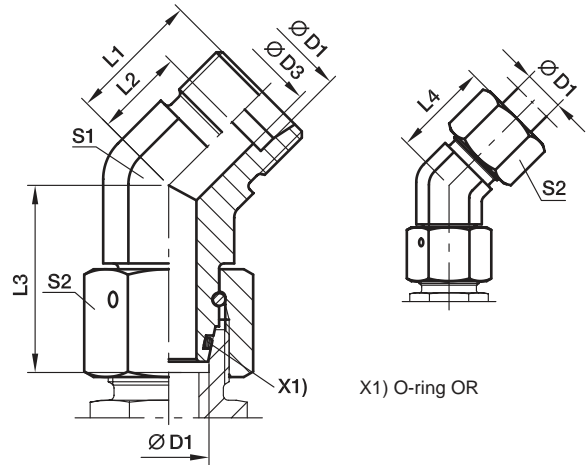

Series	D1	D3	L1	L2	L3	L4	S1	S2	Weight g/1 piece	Order code*	PN (bar) ¹⁾		
											CF	A3C	71
L ³⁾	06	4	16.0	9.0	26.0	24	14	14	37	EV06LOMD	315	315	315
	08	6	19.0	12.0	27.5	27	14	17	49	EV08LOMD	315	315	315
	10	8	19.0	12.0	29.0	27	19	19	77	EV10LOMD	315	315	315
	12	10	21.0	14.0	29.5	29	19	22	86	EV12LOMD	315	315	315
	15	12	24.0	17.0	32.5	32	22	27	144	EV15LOMD	315	315	315
	18	15	24.0	16.5	35.5	33	27	32	210	EV18LOMD	315	315	315
	22	19	26.0	18.5	38.5	35	30	36	270	EV22LOMD	160	160	160
	28	24	30.5	23.0	41.5	40	36	41	385	EV28LOMD	160	160	160
	35	30	37.0	26.5	51.0	48	50	50	805	EV35LOMD	160	160	160
	42	36	37.0	26.0	56.0	49	50	60	887	EV42LOMD	160	160	160
S ⁴⁾	06	4	16.0	9.0	27.0	24	14	17	50	EV06SOMD	630	630	630
	08	5	19.0	12.0	27.5	27	19	19	80	EV08SOMD	630	630	630
	10	7	21.0	13.5	30.0	30	19	22	95	EV10SOMD	630	630	630
	12	8	24.0	16.5	31.0	33	19	24	137	EV12SOMD	630	630	630
	16	12	24.0	15.5	36.5	34	19	30	217	EV16SOMD	400	400	400
	20	16	26.5	16.0	44.5	38	27	36	313	EV20SOMD	400	400	400
	25	20	30.5	18.5	50.0	43	36	46	529	EV25SOMD	400	400	400
	30	25	37.0	23.5	55.0	50	50	50	940	EV30SOMD	400	400	400
38	32	37.0	21.0	63.0	52	50	60	1055	EV38SOMD	315	315	315	

¹⁾ Pressure shown = item deliverable

³⁾ L = light series; ⁴⁾ S = heavy series

$\frac{PN \text{ (bar)}}{10} = PN \text{ (MPa)}$

Delivery without nut and ring. Information on ordering complete fittings or alternative sealing materials see page 17.

*Please add the **suffixes** below according to the material/surface required.

Order code suffixes			
Material	Suffix surface and material	Example	Standard sealing material (no additional suffix needed)
Steel, zinc plated, chrome ⁶⁾ -free	CF	EV16SOMDCF	NBR
Steel, zinc yellow plated	A3C	EV16SOMDA3C	NBR
Stainless Steel	71	EV16SOMD71	VIT

ET Swivel nut branch tee

EO 24° cone end / EO 24° DKO swivel

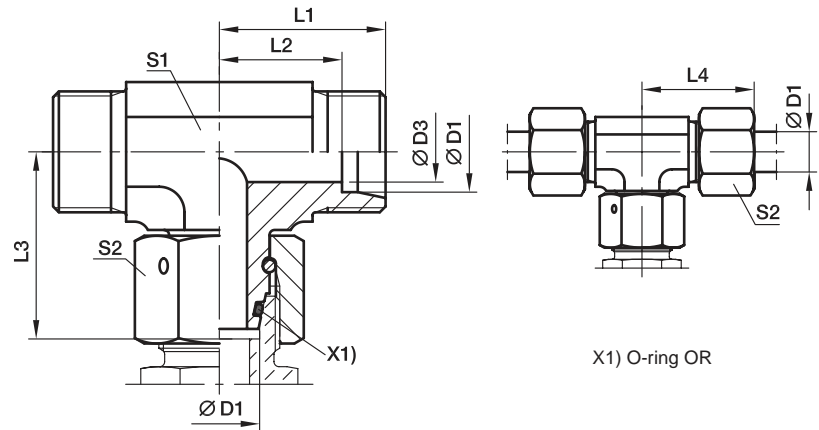

Series	D1	D3	L1	L2	L3	L4	S1	S2	Weight g/1 piece	Order code*	PN (bar) ¹⁾		
											CF	A3C	71
L ³⁾	06	4	19	12.0	26.0	27	12	14	42	ET06LOMD	500	315	315
	08	6	21	14.0	27.5	29	12	17	53	ET08LOMD	500	315	315
	10	8	22	15.0	29.0	30	14	19	71	ET10LOMD	500	315	315
	12	10	24	17.0	29.5	32	17	22	97	ET12LOMD	400	315	315
	15	12	28	21.0	32.5	36	19	27	159	ET15LOMD	400	315	315
	18	15	31	23.5	35.5	40	24	32	239	ET18LOMD	400	315	315
	22	19	35	27.5	38.5	44	27	36	308	ET22LOMD	250	160	160
	28	24	38	30.5	41.5	47	36	41	449	ET28LOMD	250	160	160
	35	30	45	34.5	51.0	56	41	50	679	ET35LOMD	250	160	160
	42	36	51	40.0	56.0	63	50	60	1131	ET42LOMD	250	160	160
S ⁴⁾	06	4	23	16.0	27.0	31	12	17	63	ET06SOMD	800	630	630
	08	5	24	17.0	27.5	32	14	19	79	ET08SOMD	800	630	630
	10	6	25	17.5	30.0	34	17	22	113	ET10SOMD	800	630	630
	12	8	29	21.5	31.0	38	17	24	136	ET12SOMD	630	630	630
	14	9	30	22.0	35.0	40	19	27	173	ET14SOMD	630	630	630
	16	12	33	24.5	36.5	43	24	30	239	ET16SOMD	630	400	400
	20	16	37	26.5	44.5	48	27	36	388	ET20SOMD	420	400	400
	25	20	42	30.0	50.0	54	36	46	652	ET25SOMD	420	400	400
	30	25	49	35.5	55.0	62	41	50	905	ET30SOMD	420	400	400
	38	32	57	41.0	63.0	72	50	60	1462	ET38SOMD	420	315	315

¹⁾ Pressure shown = item deliverable

³⁾ L = light series; ⁴⁾ S = heavy series

$$\frac{\text{PN (bar)}}{10} = \text{PN (MPa)}$$

Delivery without nut and ring. Information on ordering complete fittings or alternative sealing materials see page I7.

*Please add the **suffixes** below according to the material/surface required.

Order code suffixes			
Material	Suffix surface and material	Example	Standard sealing material (no additional suffix needed)
Steel, zinc plated, chrome ⁶ -free	CF	ET16SOMDCF	NBR
Steel, zinc yellow plated	A3C	ET16SOMDA3C	NBR
Stainless Steel	71	ET16SOMD71	VIT

EL Swivel nut run tee

EO 24° cone end / EO 24° DKO swivel

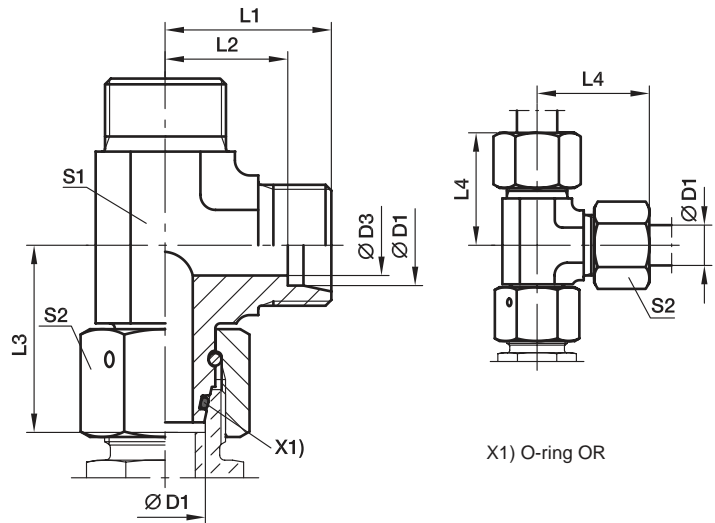

Series	D1	D3	L1	L2	L3	L4	S1	S2	Weight g/1 piece	Order code*	PN (bar) ¹⁾		
											CF	A3C	71
L ³⁾	06	4	19	12.0	26.0	27	12	14	44	EL06LOMD	500	315	315
	08	6	21	14.0	27.5	29	12	17	53	EL08LOMD	500	315	315
	10	8	22	15.0	29.0	30	14	19	68	EL10LOMD	500	315	315
	12	10	24	17.0	29.5	32	17	22	95	EL12LOMD	400	315	315
	15	12	28	21.0	32.5	36	19	27	151	EL15LOMD	400	315	315
	18	15	31	23.5	35.5	40	24	32	233	EL18LOMD	400	315	315
	22	19	35	27.5	38.5	44	27	36	309	EL22LOMD	250	160	160
	28	24	38	30.5	41.5	47	36	41	436	EL28LOMD	250	160	160
	35	30	45	34.5	51.0	56	41	50	666	EL35LOMD	250	160	160
	42	36	51	40.0	56.0	63	50	60	1163	EL42LOMD	250	160	160
S ⁴⁾	06	4	23	16.0	27.0	31	12	17	65	EL06SOMD	800	630	630
	08	5	24	17.0	27.5	32	14	19	84	EL08SOMD	800	630	630
	10	6	25	17.5	30.0	34	17	22	118	EL10SOMD	800	630	630
	12	8	29	21.5	31.0	38	17	24	136	EL12SOMD	630	630	630
	14	9	30	22.0	35.0	40	19	27	173	EL14SOMD	630	630	630
	16	12	33	24.5	36.5	43	24	30	260	EL16SOMD	630	400	400
	20	16	37	26.5	44.5	48	27	36	375	EL20SOMD	420	400	400
	25	20	42	30.0	50.0	54	36	46	655	EL25SOMD	420	400	400
	30	25	49	35.5	55.0	62	41	50	906	EL30SOMD	420	400	400
	38	32	57	41.0	63.0	72	50	60	1472	EL38SOMD	420	315	315

¹⁾ Pressure shown = item deliverable

³⁾ L = light series; ⁴⁾ S = heavy series

$\frac{PN \text{ (bar)}}{10} = PN \text{ (MPa)}$

Delivery without nut and ring. Information on ordering complete fittings or alternative sealing materials see page I7.

*Please add the **suffixes** below according to the material/surface required.

Order code suffixes			
Material	Suffix surface and material	Example	Standard sealing material (no additional suffix needed)
Steel, zinc plated, chrome ⁶ -free	CF	EL16SOMDCF	NBR
Steel, zinc yellow plated	A3C	EL16SOMDA3C	NBR
Stainless Steel	71	EL16SOMD71	VIT

EVW Standpipe elbow

EO 24° cone end / EO stand pipe adjustable

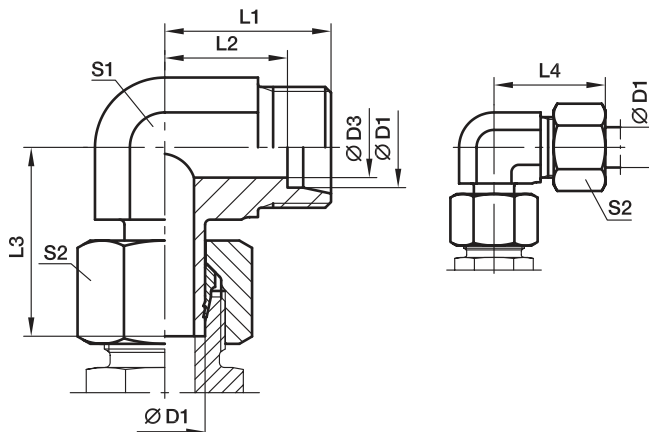

With pre-assembled nut and progressive ring for connection.
Final assembly (in appropriate body) at least 1/4 turn beyond the point of clearly perceptible resistance.

Series	D1	D3	L1	L2	L3	L4	S1	S2	Weight g/1 piece	Order code*	PN (bar) ¹⁾			
											CF	A3C	71	MS
L ³⁾	06	4	19	12.0	26.0	27	12	14	32	EVW06LOMD	315	315	315	200
	08	6	21	14.0	27.5	29	12	17	40	EVW08LOMD	315	315	315	200
	10	8	22	15.0	29.0	30	14	19	54	EVW10LOMD	315	315	315	200
	12	10	24	17.0	29.5	32	17	22	76	EVW12LOMD	315	315	315	200
	15	12	28	21.0	32.5	36	19	27	119	EVW15LOMD	315	315	315	200
	18	15	31	23.5	35.5	40	24	32	192	EVW18LOMD	315	315	315	200
	22	19	35	27.5	38.5	44	27	36	355	EVW22LOMD	160	160	160	100
	28	24	38	30.5	42.0	47	36	41	514	EVW28LOMD	160	160	160	100
	35	30	45	34.5	51.0	56	41	50	536	EVW35LOMD	160	160	160	100
	42	36	51	40.0	60.0	63	50	60	977	EVW42LOMD	160	160	160	100
S ⁴⁾	06	4	23	16.0	27.0	31	12	17	44	EVW06SOMD	630	630	630	400
	08	5	24	17.0	27.5	32	14	19	63	EVW08SOMD	630	630	630	400
	10	7	25	17.5	31.0	34	17	22	95	EVW10SOMD	630	630	630	400
	12	8	29	21.5	31.0	38	17	24	110	EVW12SOMD	630	630	630	400
	14	10	30	22.0	35.0	40	19	27	137	EVW14SOMD	400	400	400	250
	16	12	33	24.5	37.5	43	24	30	211	EVW16SOMD	400	400	400	250
	20	16	37	26.5	44.5	48	27	36	306	EVW20SOMD	400	400	400	250
	25	20	42	30.0	50.0	54	36	46	558	EVW25SOMD	400	400	400	250
	30	25	49	35.5	55.0	62	41	50	724	EVW30SOMD	400	400	400	250
	38	32	57	41.0	66.5	72	50	60	1307	EVW38SOMD	315	315	315	200

1) Pressure shown = item deliverable

3) L = light series; 4) S = heavy series

$$\frac{\text{PN (bar)}}{10} = \text{PN (MPa)}$$

Delivery without nut and ring. Information on ordering complete fittings see page 17.

*Please add the **suffixes** below according to the material/surface required.

Order code suffixes		
Material	Suffix surface and material	Example
Steel, zinc plated, chrome ⁶ -free	CF	EVW16SOMDCF
Steel, zinc yellow plated	A3C	EVW16SOMDA3C
Stainless Steel	71	EVW16SOMD71
Brass	MS	EVW16SOMDMS

EVT Standpipe branch tee

EO 24° cone end / EO stand pipe adjustable

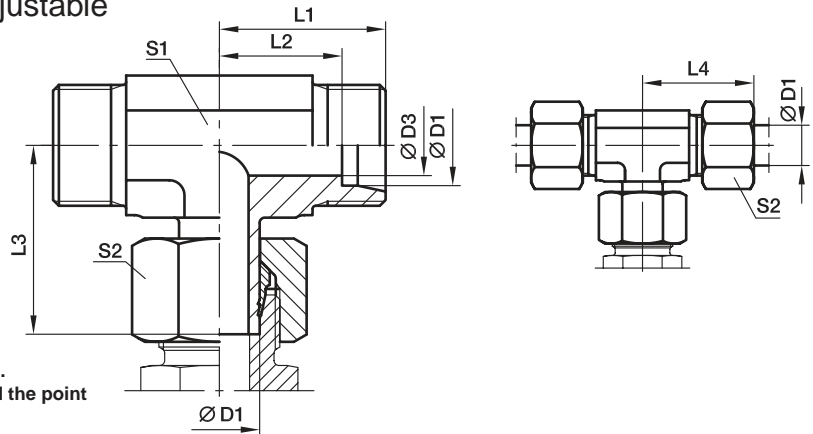

With pre-assembled nut and progressive ring for connection.
Final assembly (in appropriate body) at least 1/4 turn beyond the point of clearly perceptible resistance.

Series	D1	D3	L1	L2	L3	L4	S1	S2	Weight g/1 piece	Order code*	PN (bar) ¹⁾			
											CF	A3C	71	MS
L ³⁾	06	4	19	12.0	26.0	27	12	14	37	EVT06LOMD	315	315	315	200
	08	6	21	14.0	27.5	29	12	17	49	EVT08LOMD	315	315	315	200
	10	8	22	15.0	29.0	30	14	19	66	EVT10LOMD	315	315	315	200
	12	10	24	17.0	30.5	32	17	22	93	EVT12LOMD	315	315	315	200
	15	12	28	21.0	32.5	36	19	27	146	EVT15LOMD	315	315	315	200
	18	15	31	23.5	35.5	40	24	32	201	EVT18LOMD	315	315	315	200
	22	19	35	27.5	38.5	44	27	36	274	EVT22LOMD	160	160	160	
	28	24	38	30.5	43.5	47	36	41	441	EVT28LOMD	160	160	160	
	35	30	45	34.5	54.5	56	41	50	633	EVT35LOMD	160	160	160	
	42	36	51	40.0	60.0	63	50	60	1129	EVT42LOMD	160	160	160	
S ⁴⁾	06	4	23	16.0	27.0	31	12	17	61	EVT06SOMD	630	630	630	
	08	5	24	17.0	29.0	32	14	19	44	EVT08SOMD	630	630	630	
	10	7	25	17.5	31.0	34	17	22	84	EVT10SOMD	630	630	630	
	12	8	29	21.5	33.0	38	17	24	131	EVT12SOMD	630	630	630	
	14	10	30	22.0	35.0	40	19	27	173	EVT14SOMD	400	400	400	
	16	12	33	24.5	37.5	43	24	30	240	EVT16SOMD	400	400	400	
	20	16	37	26.5	44.5	48	27	36	345	EVT20SOMD	400	400	400	
	25	20	42	30.0	50.5	54	36	46	647	EVT25SOMD	400	400	400	
	30	25	49	35.5	56.5	62	41	50	873	EVT30SOMD	400	400	400	
	38	32	57	41.0	66.5	72	50	60	1361	EVT38SOMD	315	315	315	

1) Pressure shown = item deliverable

3) L = light series; 4) S = heavy series

$$\frac{PN \text{ (bar)}}{10} = PN \text{ (MPa)}$$

Delivery without nut and ring. Information on ordering complete fittings see page 17.

*Please add the **suffixes** below according to the material/surface required.

Order code suffixes		
Material	Suffix surface and material	Example
Steel, zinc plated, chrome ⁶ -free	CF	EVT16SOMDCF
Steel, zinc yellow plated	A3C	EVT16SOMDA3C
Stainless Steel	71	EVT16SOMD71
Brass	MS	EVT18LOMDMS

EVL standpipe run tee

EO 24° cone end / EO stand pipe adjustable

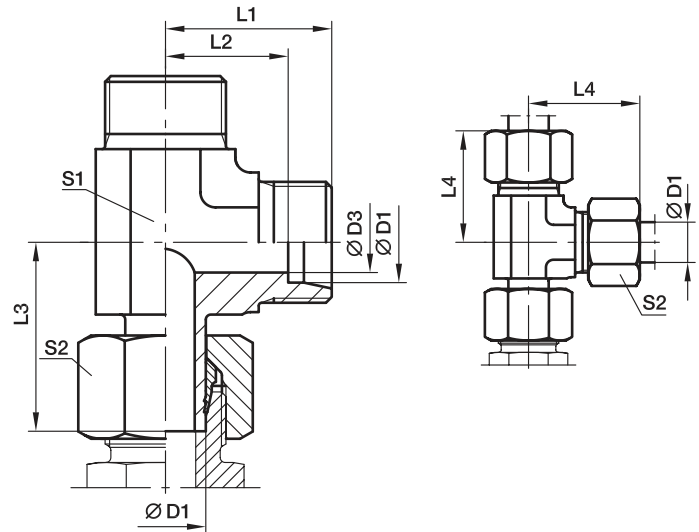

With pre-assembled nut and progressive ring for connection.
Final assembly (in appropriate body) at least 1/4 turn beyond the point of clearly perceptible resistance.

Series	D1	D3	L1	L2	L3	L4	S1	S2	Weight g/1 piece	Order code*	PN (bar) ¹⁾			
											CF	A3C	71	MS
L ³⁾	06	4	19	12.0	26.0	27	12	14	40	EVL06LOMD	315	315	315	200
	08	6	21	14.0	27.5	29	12	17	50	EVL08LOMD	315	315	315	200
	10	8	22	15.0	29.0	30	14	19	64	EVL10LOMD	315	315	315	200
	12	10	24	17.0	30.5	32	17	22	93	EVL12LOMD	315	315	315	200
	15	12	28	21.0	32.5	36	19	27	147	EVL15LOMD	315	315	315	200
	18	15	31	23.5	35.5	40	24	32	229	EVL18LOMD	315	315	315	200
	22	19	35	27.5	39.0	44	27	36	296	EVL22LOMD	160	160	160	
	28	24	38	30.5	43.5	47	36	41	416	EVL28LOMD	160	160	160	
	35	30	45	34.5	54.5	56	41	50	661	EVL35LOMD	160	160	160	
	42	36	51	40.0	60.0	63	50	60	1105	EVL42LOMD	160	160	160	
S ⁴⁾	06	4	23	16.0	27.0	31	12	17	57	EVL06SOMD	630	630	630	
	08	5	24	17.0	29.0	32	14	19	84	EVL08SOMD	630	630	630	
	10	7	25	17.5	32.0	34	17	22	116	EVL10SOMD	630	630	630	
	12	8	29	21.5	33.0	38	17	24	137	EVL12SOMD	630	630	630	
	14	10	30	22.0	35.0	40	19	27	175	EVL14SOMD	400	400	400	
	16	12	33	24.5	37.5	43	24	30	259	EVL16SOMD	400	400	400	
	20	16	37	26.5	44.5	48	27	36	371	EVL20SOMD	400	400	400	
	25	20	42	30.0	50.5	54	36	46	647	EVL25SOMD	400	400	400	
	30	25	49	35.5	56.5	62	41	50	906	EVL30SOMD	400	400	400	
	38	32	57	41.0	66.5	72	50	60	1549	EVL38SOMD	315	315	315	

¹⁾ Pressure shown = item deliverable

³⁾ L = light series; ⁴⁾ S = heavy series

$$\frac{\text{PN (bar)}}{10} = \text{PN (MPa)}$$

Delivery without nut and ring. Information on ordering complete fittings see page 17.

*Please add the **suffixes** below according to the material/surface required.

Order code suffixes		
Material	Suffix surface and material	Example
Steel, zinc plated, chrome ⁶ -free	CF	EVL16SOMDCF
Steel, zinc yellow plated	A3C	EVL16SOMDA3C
Stainless Steel	71	EVL16SOMD71
Brass	MS	EVL18LOMDMS

DA Distance piece adapter

EO 24° DKO swivel / EO 24° cone end

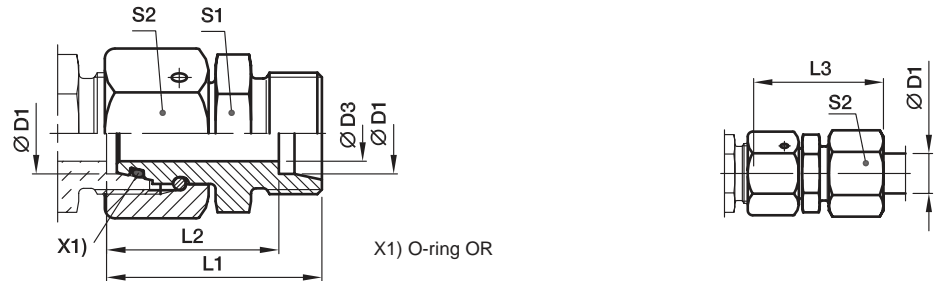

Series	D1	D3	L1	L2	L3	S1	S2	Weight g/1 piece	Order code*	PN (bar) ¹⁾			
										CF	A3C	71	MS
L ³⁾	06	2.5	43.0	36	51	12	14	33	DA06LOMD	500	315	315	200
	08	4.0	43.0	36	51	14	17	46	DA08LOMD	500	315	315	200
	10	6.0	43.0	36	51	17	19	60	DA10LOMD	500	315	315	200
	12	8.0	43.0	36	51	19	22	75	DA12LOMD	400	315	315	200
	15	10.0	43.0	36	51	24	27	118	DA15LOMD	400	315	315	200
	18	13.0	43.5	36	52	27	32	153	DA18LOMD	400	315	315	200
	22	17.0	47.5	40	56	32	36	210	DA22LOMD	250	160	160	100
	28	22.0	47.5	40	57	41	41	279	DA28LOMD	250	160	160	100
	35	28.0	60.5	50	72	46	50	468	DA35LOMD	250	160	160	100
	42	34.0	71.0	60	83	55	60	802	DA42LOMD	250	160	160	100
S ⁴⁾	06	2.5	43.0	36	51	14	17	48	DA06SOMD	800	630	630	400
	08	4.0	43.0	36	51	17	19	64	DA08SOMD	800	630	630	400
	10	6.0	43.5	36	52	19	22	81	DA10SOMD	800	630	630	400
	12	8.0	43.5	36	52	22	24	97	DA12SOMD	630	630	630	400
	14	9.0	48.0	40	58	24	27	133	DA14SOMD	630	630	630	400
	16	11.0	48.5	40	58	27	30	166	DA16SOMD	630	400	400	250
	20	14.0	56.5	46	68	32	36	265	DA20SOMD	420	400	400	250
	25	18.0	62.0	50	74	41	46	466	DA25SOMD	420	400	400	250
	30	23.0	69.5	56	83	46	50	601	DA30SOMD	420	400	400	250
	38	30.0	76.0	60	91	55	60	871	DA38SOMD	420	315	315	200

¹⁾ Pressure shown = item deliverable

³⁾ L = light series; ⁴⁾ S = heavy series

$\frac{PN \text{ (bar)}}{10} = PN \text{ (MPa)}$

Delivery without nut and ring. Information on ordering complete fittings or alternative sealing materials see page I7.

*Please add the **suffixes** below according to the material/surface required.

Order code suffixes			
Material	Suffix surface and material	Example	Standard sealing material (no additional suffix needed)
Steel, zinc plated, chrome ⁶ -free	CF	DA16SOMDCF	NBR
Stahl, zinc yellow plated	A3C	DA16SOMDA3C	NBR
Stainless Steel	71	DA16SOMD71	VIT
Brass	MS	DA16SOMDMS	NBR

RED Tube end reducer

EO 24° DKO swivel / EO 24° cone end

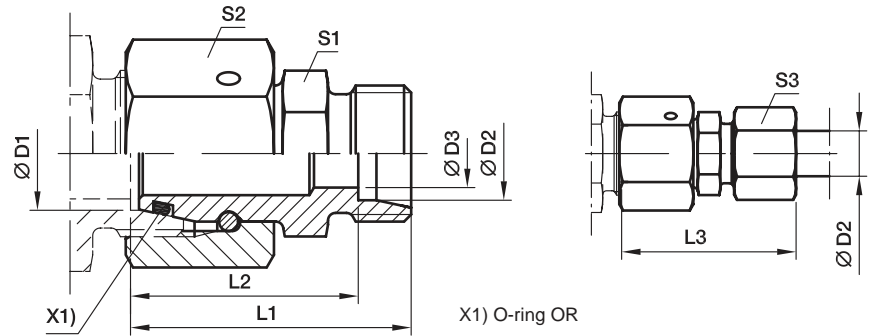

Series 2) 3) 4)	D1	D2	D3	L1	L2	L3	S1	S2	S3	Weight g/1 piece	Order code*	PN (bar) ¹⁾		
												CF	A3C	71
L/LL	06	04	2.5	28.5	24.5	34.0	9	14	10	17	RED06L/04LLOMD	100	100	100
L	08	06	4.0	30.5	23.5	38.0	12	17	14	29	RED08/06LOMD	500	315	315
L	10	06	4.0	32.0	25.0	40.0	14	19	14	36	RED10/06LOMD	500	315	315
L	10	08	6.0	32.0	25.0	40.0	14	19	17	38	RED10/08LOMD	500	315	315
L	12	06	4.0	32.0	25.0	40.0	17	22	14	49	RED12/06LOMD	400	315	315
L	12	08	6.0	32.0	25.0	40.0	17	22	17	49	RED12/08LOMD	400	315	315
L	12	10	8.0	33.0	26.0	41.0	17	22	19	51	RED12/10LOMD	400	315	315
L	15	06	4.0	35.5	28.5	43.0	19	27	14	81	RED15/06LOMD	400	315	315
L	15	08	6.0	35.5	28.5	43.0	19	27	17	85	RED15/08LOMD	400	315	315
L	15	10	8.0	36.5	29.5	44.0	19	27	19	83	RED15/10LOMD	400	315	315
L	15	12	10.0	36.5	29.5	44.0	19	27	22	83	RED15/12LOMD	400	315	315
L	18	06	4.0	35.0	28.0	43.0	24	32	14	109	RED18/06LOMD	400	315	315
L	18	08	6.0	35.0	28.0	43.0	24	32	17	111	RED18/08LOMD	400	315	315
L	18	10	8.0	36.0	29.0	44.0	24	32	19	110	RED18/10LOMD	400	315	315
L	18	12	10.0	36.0	29.0	44.0	24	32	22	110	RED18/12LOMD	400	315	315
L	18	15	12.0	37.0	30.0	45.0	24	32	27	115	RED18/15LOMD	400	315	315
L/S	18	16	12.0	40.0	31.5	49.5	27	32	30	138	RED18L/16SOMD	400	315	315
L	22	06	4.0	39.0	32.0	47.0	27	36	14	158	RED22/06LOMD	250	160	160
L	22	08	6.0	39.0	32.0	47.0	27	36	17	158	RED22/08LOMD	250	160	160
L	22	10	8.0	40.0	33.0	48.0	27	36	19	159	RED22/10LOMD	250	160	160
L	22	12	10.0	40.0	33.0	48.0	27	36	22	157	RED22/12LOMD	250	160	160
L	22	15	12.0	41.0	34.0	49.0	27	36	27	164	RED22/15LOMD	250	160	160
L/S	22	16	12.0	43.0	34.5	52.5	27	36	30	173	RED22L/16SOMD	250	160	160
L	22	18	15.0	41.0	33.5	50.0	27	36	32	167	RED22/18LOMD	250	160	160
L/S	22	20	16.0	45.0	34.5	56.0	32	36	36	203	RED22L/20SOMD	250	160	160
L	28	06	4.0	41.0	34.0	49.0	32	41	14	219	RED28/06LOMD	250	160	160
L	28	08	6.0	41.0	34.0	49.0	32	41	17	221	RED28/08LOMD	250	160	160
L	28	10	8.0	42.0	35.0	50.0	32	41	19	213	RED28/10LOMD	250	160	160
L	28	12	10.0	42.0	35.0	50.0	32	41	22	213	RED28/12LOMD	250	160	160
L	28	15	12.0	43.0	36.0	51.0	32	41	27	218	RED28/15LOMD	250	160	160
L/S	28	16	12.0	45.0	36.5	54.5	32	41	30	227	RED28L/16SOMD	250	160	160
L	28	18	15.0	43.0	35.5	52.0	32	41	32	220	RED28/18LOMD	250	160	160
L	28	22	19.0	45.0	37.5	54.0	32	41	36	222	RED28/22LOMD	250	160	160
L/S	28	25	20.0	50.0	38.0	62.0	41	41	46	300	RED28L/25SOMD	250	160	160
L	35	06	4.0	44.0	37.0	52.0	41	50	14	318	RED35/06LOMD	250	160	160
L	35	08	6.0	44.0	37.0	52.0	41	50	17	318	RED35/08LOMD	250	160	160
L	35	10	8.0	45.0	38.0	53.0	41	50	19	318	RED35/10LOMD	250	160	160
L	35	12	10.0	45.0	38.0	53.0	41	50	22	324	RED35/12LOMD	250	160	160
L	35	15	12.0	46.0	39.0	54.0	41	50	27	328	RED35/15LOMD	250	160	160
L	35	18	15.0	46.0	38.5	55.0	41	50	32	328	RED35/18LOMD	250	160	160
L	35	22	19.0	48.0	40.5	57.0	41	50	36	331	RED35/22LOMD	250	160	160

RED Tube end reducer

EO 24° DKO swivel / EO 24° cone end

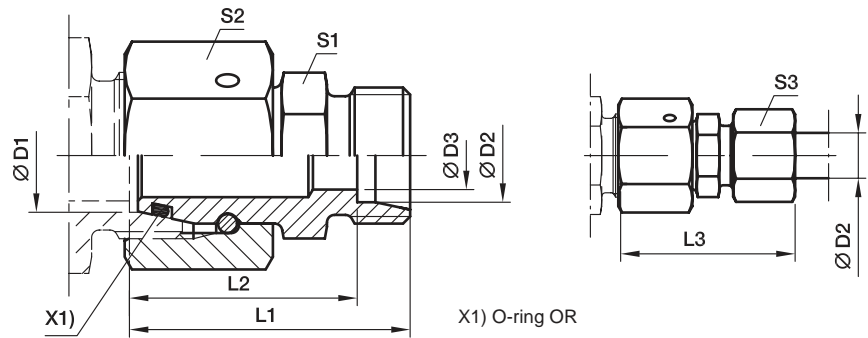

Series 2) 3) 4)	D1	D2	D3	L1	L2	L3	S1	S2	S3	Weight g/1 piece	Order code*	PN (bar) ¹⁾		
												CF	A3C	71
L/S	35	25	20.0	52.0	40.0	64.0	41	50	46	366	RED35L/25SOMD	250	160	160
L	35	28	24.0	48.0	40.5	57.0	41	50	41	327	RED35/28LOMD	250	160	160
L/S	35	30	25.0	55.0	41.5	68.0	46	50	50	435	RED35L/30SOMD	250	160	160
L	42	10	8.0	48.5	41.5	56.0	50	60	19	537	RED42/10LOMD	250	160	160
L	42	12	10.0	48.5	41.5	56.0	50	60	22	538	RED42/12LOMD	250	160	160
L	42	15	12.0	49.5	42.5	58.0	50	60	27	534	RED42/15LOMD	250	160	160
L	42	18	15.0	49.5	42.0	58.0	50	60	32	544	RED42/18LOMD	250	160	160
L	42	22	19.0	51.5	44.0	60.0	50	60	36	543	RED42/22LOMD	250	160	160
L	42	28	24.0	51.5	44.0	61.0	50	60	41	539	RED42/28LOMD	250	160	160
L/S	42	30	25.0	57.5	44.0	70.5	50	60	50	588	RED42L/30SOMD	250	160	160
L	42	35	30.0	53.5	43.0	65.0	50	60	50	541	RED42/35LOMD	250	160	160
L/S	42	38	32.0	61.5	45.5	76.0	55	60	60	701	RED42L/38SOMD	250	160	160

1) Pressure shown = item deliverable

2) LL = very light series; 3) L = light series; 4) S = heavy series

$\frac{PN(\text{bar})}{10} = PN(\text{MPa})$

Delivery without nut and ring. Information on ordering complete fittings or alternative sealing materials see page I7.

*Please add the **suffixes** below according to the material/surface required.

Order code suffixes			
Material	Suffix surface and material	Example	Standard sealing material (no additional suffix needed)
Steel, zinc plated, chrome ⁶ -free	CF	RED18/15LOMDCF	NBR
Steel, zinc yellow plated	A3C	RED18/15LOMDA3C	NBR
Stainless Steel	71	RED18/15LOMD71	VIT

RED Tube end reducer

EO 24° DKO swivel / EO 24° cone end

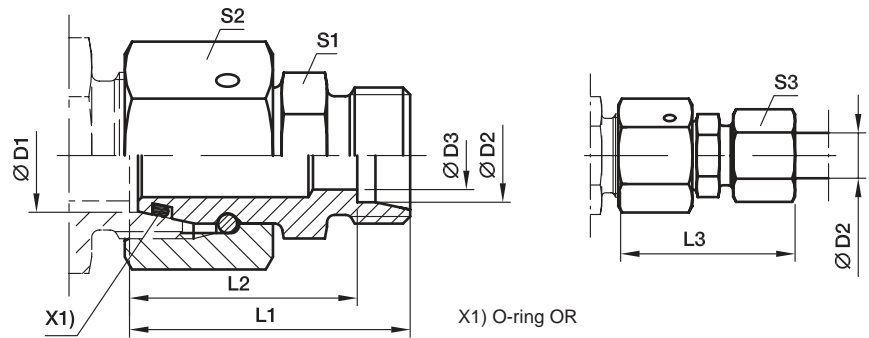

Series ^{3) 4)}	D1	D2	D3	L1	L2	L3	S1	S2	S3	Weight g/1 piece	Order code*	PN (bar) ¹⁾		
												CF	A3C	71
S	08	06	4	34.0	27.0	42	14	19	17	42	RED08/06SOMD	800	630	630
S	10	06	4	34.5	27.5	42	17	22	17	55	RED10/06SOMD	800	630	630
S	10	08	5	34.5	27.5	42	17	22	19	58	RED10/08SOMD	800	630	630
S	12	06	4	36.0	29.0	44	17	24	17	66	RED12/06SOMD	630	630	630
S	12	08	5	36.0	29.0	44	17	24	19	68	RED12/08SOMD	630	630	630
S	12	10	7	37.0	29.5	46	19	24	22	75	RED12/10SOMD	630	630	630
S	14	06	4	38.5	31.5	46	19	27	17	88	RED14/06SOMD	630	630	630
S	14	08	5	38.5	31.5	46	19	27	19	90	RED14/08SOMD	630	630	630
S	14	10	7	38.5	31.0	47	19	27	22	91	RED14/10SOMD	630	630	630
S	14	12	8	38.5	31.0	47	22	27	24	100	RED14/12SOMD	630	630	630
S	16	06	4	39.0	32.0	47	22	30	17	112	RED16/06SOMD	630	400	400
S	16	08	5	39.0	32.0	47	22	30	19	114	RED16/08SOMD	630	400	400
S	16	10	7	39.0	31.5	48	22	30	22	115	RED16/10SOMD	630	400	400
S	16	12	8	39.0	31.5	48	22	30	24	118	RED16/12SOMD	630	400	400
S	16	14	10	41.0	33.0	51	24	30	27	128	RED16/14SOMD	630	400	400
S/L	16	15	11	39.0	32.0	47	24	30	27	120	RED16S/15LOMD	400	315	315
S	20	06	4	43.0	36.0	51	27	36	17	172	RED20/06SOMD	420	400	400
S	20	08	5	43.0	36.0	51	27	36	19	174	RED20/08SOMD	420	400	400
S	20	10	7	43.0	35.5	52	27	36	22	174	RED20/10SOMD	420	400	400
S	20	12	8	43.0	35.5	52	27	36	24	177	RED20/12SOMD	420	400	400
S	20	14	10	45.0	37.0	55	27	36	27	182	RED20/14SOMD	420	400	400
S/L	20	15	12	43.0	36.0	51	27	36	27	173	RED20S/15LOMD	400	315	315
S	20	16	12	45.0	36.5	55	27	36	30	182	RED20/16SOMD	420	400	400
S/L	20	18	14	43.0	35.5	51	27	36	32	178	RED20S/18LOMD	400	315	315
S	25	06	4	45.5	38.5	53	32	46	17	294	RED25/06SOMD	420	400	400
S	25	08	5	45.5	38.5	53	32	46	19	295	RED25/08SOMD	420	400	400
S	25	10	7	45.5	38.0	54	32	46	22	296	RED25/10SOMD	420	400	400
S	25	12	8	45.5	38.0	54	32	46	24	299	RED25/12SOMD	420	400	400
S	25	14	10	47.5	39.5	57	32	46	27	303	RED25/14SOMD	420	400	400
S	25	16	12	47.5	39.0	57	32	46	30	304	RED25/16SOMD	420	400	400
S/L	25	18	15	45.5	38.0	54	32	46	32	299	RED25S/18LOMD	400	315	315
S	25	20	16	49.5	39.0	61	32	46	36	315	RED25/20SOMD	420	400	400
S/L	25	22	18	47.5	40.0	56	32	46	36	304	RED25S/22LOMD	250	160	160
S	30	06	4	51.0	44.0	59	41	50	17	412	RED30/06SOMD	420	400	400
S	30	08	5	51.0	44.0	59	41	50	19	404	RED30/08SOMD	420	400	400
S	30	10	7	51.0	43.5	60	41	50	22	405	RED30/10SOMD	420	400	400
S	30	12	8	51.0	43.5	60	41	50	24	405	RED30/12SOMD	420	400	400
S	30	14	10	53.0	45.0	63	41	50	27	408	RED30/14SOMD	420	400	400
S	30	16	12	53.0	44.5	63	41	50	30	412	RED30/16SOMD	420	400	400
S	30	20	16	55.0	44.5	66	41	50	36	421	RED30/20SOMD	420	400	400

RED Tube end reducer

EO 24° DKO swivel / EO 24° cone end

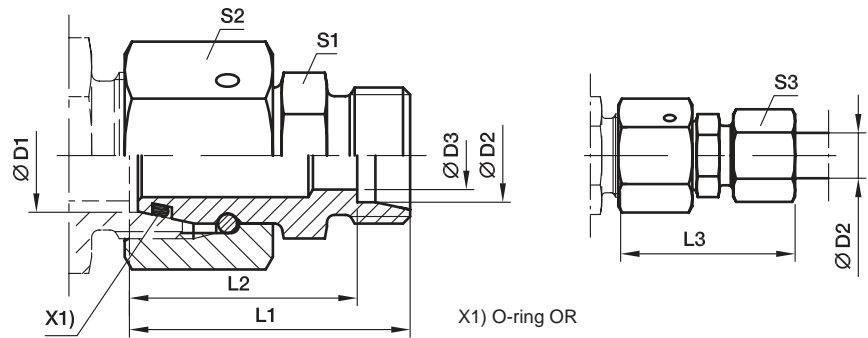

Series ^{3) 4)}	D1	D2	D3	L1	L2	L3	S1	S2	S3	Weight g/1 piece	Order code*	PN (bar) ¹⁾		
												CF	A3C	71
S/L	30	22	19	53.0	45.5	61	41	50	36	406	RED30S/22LOMD	250	160	160
S	30	25	20	57.0	45.0	69	41	50	46	439	RED30/25SOMD	420	400	400
S/L	30	28	23	53.0	45.5	62	41	50	41	406	RED30S/28LOMD	250	160	160
S	38	06	4	54.5	47.5	62	50	60	17	556	RED38/06SOMD	420	315	315
S	38	08	5	54.5	47.5	62	50	60	19	581	RED38/08SOMD	420	315	315
S	38	10	7	54.5	47.0	63	50	60	22	579	RED38/10SOMD	420	315	315
S	38	12	8	54.5	47.0	63	50	60	24	577	RED38/12SOMD	420	315	315
S	38	14	10	56.5	48.5	66	50	60	27	579	RED38/14SOMD	420	315	315
S	38	16	12	56.5	48.0	66	50	60	30	580	RED38/16SOMD	420	315	315
S	38	20	16	58.5	48.0	70	50	60	36	601	RED38/20SOMD	420	315	315
S	38	25	20	60.5	48.5	73	50	60	46	615	RED38/25SOMD	420	315	315
S/L	38	28	24	56.5	49.0	65	50	60	41	573	RED38S/28LOMD	250	160	160
S	38	30	25	62.5	49.0	76	50	60	50	625	RED38/30SOMD	420	315	315
S/L	38	35	30	58.5	48.0	69	50	60	50	588	RED38S/35LOMD	250	160	160

¹⁾ Pressure shown = item deliverable

³⁾ L = light series; ⁴⁾ S = heavy series

$$\frac{\text{PN (bar)}}{10} = \text{PN (MPa)}$$

Delivery without nut and ring. Information on ordering complete fittings or alternative sealing materials see page 17.

*Please add the **suffixes** below according to the material/surface required.

Order code suffixes			
Material	Suffix surface and material	Example	Standard sealing material (no additional suffix needed)
Steel, zinc plated, chrome ⁶⁾ -free	CF	RED16/12SOMDCF	NBR
Steel, zinc yellow plated	A3C	RED16/12SOMDA3C	NBR
Stainless Steel	71	RED16/12SOMD71	VIT

KOR Tube end reducer – Steel and Brass

EO stand pipe adjustable / EO 24° cone end

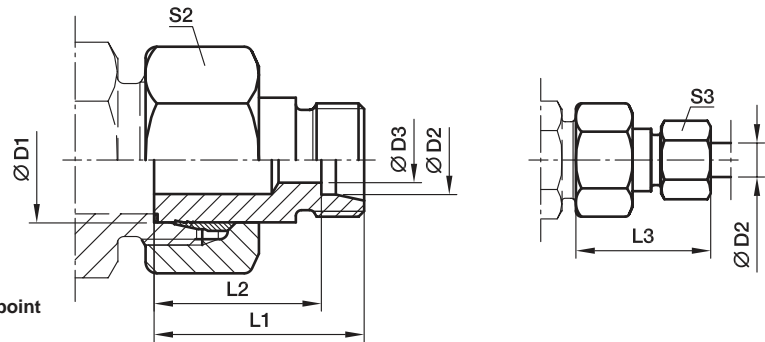

With pre-assembled nut and progressive ring for connection.
Final assembly (in appropriate body) at least 1/4 turn beyond the point of clearly perceptible resistance.

Series 2) 3)	D1	D2	D3	L1	L2	L3	S2	S3	Weight g/1 piece	Order code*	PN (bar) ¹⁾		
											CF	A3C	MS
LL	06	04	3.0	28.5	24.5	34	12	10	16	KOR06/04LLOMD	100	100	
LL	08	04	3.0	28.5	24.5	34	14	10	16	KOR08/04LLOMD	100	100	
LL	08	06	4.5	23.0	17.5	29	14	12	14	KOR08/06LLOMD	100	100	
L/LL	06	04	3.0	28.5	24.5	34	14	10	16	KOR06L/04LLOMD	100	100	
L/LL	08	04	3.0	28.5	24.5	34	17	10	16	KOR08L/04LLOMD	100	100	
L	08	06	4.0	30.5	23.5	38	17	14	27	KOR08/06LOMD	315	315	200
L/LL	10	04	3.0	28.5	24.5	34	19	10	32	KOR10L/04LLOMD	100	100	
L	10	06	4.0	30.5	23.5	38	19	14	34	KOR10/06LOMD	315	315	200
L	10	08	6.0	30.5	23.5	38	19	17	35	KOR10/08LOMD	315	315	200
L/LL	12	04	3.0	28.5	24.5	34	22	10	41	KOR12L/04LLOMD	100	100	
L	12	06	4.0	30.5	23.5	38	22	14	45	KOR12/06LOMD	315	315	200
L	12	08	6.0	30.5	23.5	38	22	17	45	KOR12/08LOMD	315	315	200
L	12	10	8.0	31.5	24.5	39	22	19	46	KOR12/10LOMD	315	315	200
L	15	06	4.0	30.5	23.5	38	27	14	68	KOR15/06LOMD	315	315	200
L	15	08	6.0	30.5	23.5	38	27	17	69	KOR15/08LOMD	315	315	200
L	15	10	8.0	31.5	24.5	39	27	19	70	KOR15/10LOMD	315	315	200
L	15	12	10.0	31.5	24.5	39	27	22	70	KOR15/12LOMD	315	315	200
L	18	06	4.0	31.5	24.5	39	32	14	100	KOR18/06LOMD	315	315	200
L	18	08	6.0	31.5	24.5	39	32	17	102	KOR18/08LOMD	315	315	200
L	18	10	8.0	32.5	25.5	40	32	19	102	KOR18/10LOMD	315	315	200
L	18	12	10.0	32.5	25.5	40	32	22	101	KOR18/12LOMD	315	315	200
L	18	15	12.0	33.5	26.5	42	32	27	106	KOR18/15LOMD	315	315	200
L	22	06	4.0	32.5	25.5	40	36	14	137	KOR22/06LOMD	160	160	100
L	22	08	6.0	32.5	25.5	40	36	17	136	KOR22/08LOMD	160	160	100
L	22	10	8.0	33.5	26.5	41	36	19	138	KOR22/10LOMD	160	160	100
L	22	12	10.0	33.5	26.5	41	36	22	138	KOR22/12LOMD	160	160	100
L	22	15	12.0	34.5	27.5	43	36	27	143	KOR22/15LOMD	160	160	100
L	22	18	15.0	34.5	27.0	43	36	32	143	KOR22/18LOMD	160	160	100
L	28	06	4.0	33.5	26.5	41	41	14	177	KOR28/06LOMD	160	160	100
L	28	08	6.0	33.5	26.5	41	41	17	179	KOR28/08LOMD	160	160	100
L	28	10	8.0	34.5	27.5	42	41	19	180	KOR28/10LOMD	160	160	100
L	28	12	10.0	34.5	27.5	42	41	22	180	KOR28/12LOMD	160	160	100
L	28	15	12.0	35.5	28.5	44	41	27	185	KOR28/15LOMD	160	160	100
L	28	18	15.0	35.5	28.0	44	41	32	184	KOR28/18LOMD	160	160	100
L	28	22	19.0	37.5	30.0	46	41	36	188	KOR28/22LOMD	160	160	100
L	35	06	4.0	38.5	31.5	46	50	14	302	KOR35/06LOMD	160	160	
L	35	08	6.0	38.5	31.5	46	50	17	306	KOR35/08LOMD	160	160	
L	35	10	8.0	39.5	32.5	47	50	19	305	KOR35/10LOMD	160	160	100
L	35	12	10.0	39.5	32.5	47	50	22	304	KOR35/12LOMD	160	160	100
L	35	15	12.0	40.5	33.5	49	50	27	308	KOR35/15LOMD	160	160	100
L	35	18	15.0	40.5	33.0	49	50	32	316	KOR35/18LOMD	160	160	100
L	35	22	19.0	42.5	35.0	51	50	36	310	KOR35/22LOMD	160	160	100
L	35	28	24.0	42.5	35.0	52	50	41	305	KOR35/28LOMD	160	160	100

KOR Tube end reducer – Steel and Brass

EO stand pipe adjustable / EO 24° cone end

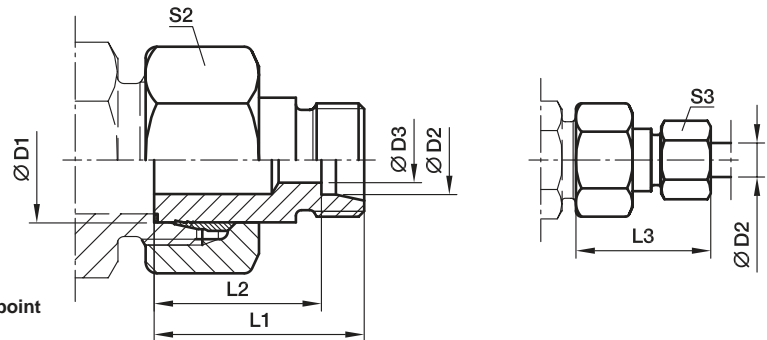

With pre-assembled nut and progressive ring for connection.
Final assembly (in appropriate body) at least 1/4 turn beyond the point of clearly perceptible resistance.

Series ²⁾ ³⁾	D1	D2	D3	L1	L2	L3	S2	S3	Weight g/1 piece	Order code*	PN (bar) ¹⁾		
											CF	A3C	MS
L	42	10	8.0	40.5	33.5	48	60	19	455	KOR42/10LOMD	160	160	
L	42	12	10.0	40.5	33.5	48	60	22	438	KOR42/12LOMD	160	160	
L	42	15	12.0	41.5	34.5	50	60	27	438	KOR42/15LOMD	160	160	100
L	42	18	15.0	41.5	34.0	50	60	32	449	KOR42/18LOMD	160	160	100
L	42	22	19.0	43.5	36.0	52	60	36	461	KOR42/22LOMD	160	160	100
L	42	28	24.0	43.5	36.0	53	60	41	443	KOR42/28LOMD	160	160	100
L	42	35	30.0	45.5	35.0	57	60	50	444	KOR42/35LOMD	160	160	100

¹⁾ Pressure shown = item deliverable

²⁾ LL = very light series; ³⁾ L = light series

$\frac{\text{PN (bar)}}{10} = \text{PN (MPa)}$

Delivery without nut and ring. Information on ordering complete fittings see page I7.

*Please add the **suffixes** below according to the material/surface required.

Order code suffixes		
Material	Suffix surface and material	Example
Steel, zinc plated, chrome ⁶ -free	CF	KOR18/15LOMDCF
Steel, zinc yellow plated	A3C	KOR18/15LOMDA3C
Brass	MS	KOR18/15LOMDMS

KOR Tube end reducer – Steel and Brass

EO stand pipe adjustable / EO 24° cone end

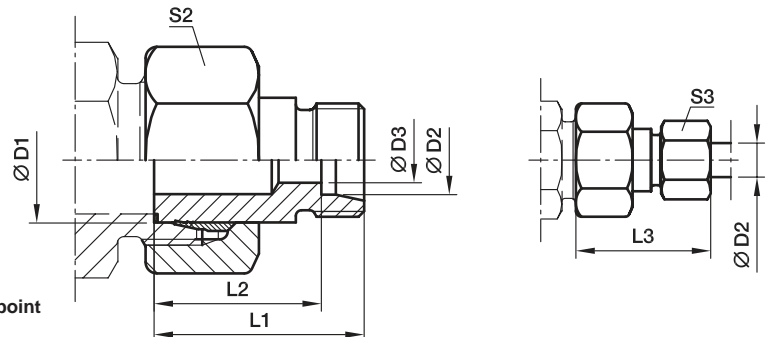

With pre-assembled nut and progressive ring for connection.
Final assembly (in appropriate body) at least 1/4 turn beyond the point of clearly perceptible resistance.

Series	D1	D2	D3	L1	L2	L3	S2	S3	Weight g/1 piece	Order code*	PN (bar) ¹⁾		
											CF	A3C	MS
S ⁴⁾	08	06	4	32	25.0	40	19	17	37	KOR08/06SOMD	630	630	400
	10	06	4	33	26.0	41	22	17	53	KOR10/06SOMD	630	630	400
	10	08	5	33	26.0	41	22	19	55	KOR10/08SOMD	630	630	400
	12	06	4	34	27.0	42	24	17	61	KOR12/06SOMD	630	630	400
	12	08	5	34	27.0	42	24	19	63	KOR12/08SOMD	630	630	400
	12	10	7	34	26.5	43	24	22	64	KOR12/10SOMD	630	630	400
	14	06	4	36	29.0	44	27	17	88	KOR14/06SOMD	630	630	400
	14	08	5	36	29.0	44	27	19	89	KOR14/08SOMD	630	630	400
	14	10	7	36	28.5	45	27	22	91	KOR14/10SOMD	630	630	400
	14	12	8	36	28.5	45	27	24	92	KOR14/12SOMD	630	630	400
16	06	4	36	29.0	44	30	17	106	KOR16/06SOMD	400	400	250	
	08	5	36	29.0	44	30	19	108	KOR16/08SOMD	400	400	250	
	10	7	36	28.5	45	30	22	114	KOR16/10SOMD	400	400	250	
	12	8	36	28.5	45	30	24	115	KOR16/12SOMD	400	400	250	
	14	10	8	38	30.0	48	30	27	116	KOR16/14SOMD	400	400	250
20	06	4	41	34.0	49	36	17	175	KOR20/06SOMD	400	400	250	
	08	5	41	34.0	49	36	19	177	KOR20/08SOMD	400	400	250	
	10	7	41	33.5	50	36	22	178	KOR20/10SOMD	400	400	250	
	12	8	41	33.5	50	36	24	180	KOR20/12SOMD	400	400	250	
	14	10	41	33.0	51	36	27	180	KOR20/14SOMD	400	400	250	
25	06	4	44	37.0	52	46	17	306	KOR25/06SOMD	400	400	250	
	08	5	44	37.0	52	46	19	311	KOR25/08SOMD	400	400	250	
	10	7	44	36.5	53	46	22	313	KOR25/10SOMD	400	400	250	
	12	8	44	36.5	53	46	24	317	KOR25/12SOMD	400	400	250	
	14	10	45	37.0	55	46	27	312	KOR25/14SOMD	400	400	250	
30	06	4	46	39.0	54	50	17	373	KOR30/06SOMD	400	400	250	
	08	5	46	39.0	54	50	19	376	KOR30/08SOMD	400	400	250	
	10	7	46	38.5	55	50	22	376	KOR30/10SOMD	400	400	250	
	12	8	46	38.5	55	50	24	377	KOR30/12SOMD	400	400	250	
	14	10	48	40.0	58	50	27	379	KOR30/14SOMD	400	400	250	
38	06	4	50	43.0	58	60	17	571	KOR38/06SOMD	315	315	200	
	08	5	50	43.0	58	60	19	567	KOR38/08SOMD	315	315	200	
	10	7	50	42.5	59	60	22	571	KOR38/10SOMD	315	315	200	
	12	8	50	42.5	59	60	24	571	KOR38/12SOMD	315	315	200	

KOR Tube end reducer – Steel and Brass

EO stand pipe adjustable / EO 24° cone end

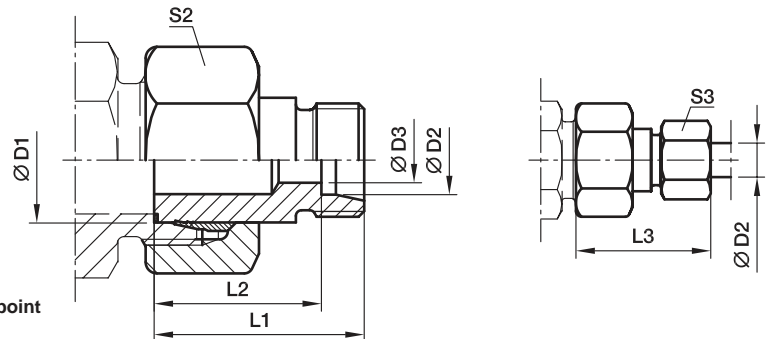

With pre-assembled nut and progressive ring for connection.
Final assembly (in appropriate body) at least 1/4 turn beyond the point of clearly perceptible resistance.

Series	D1	D2	D3	L1	L2	L3	S2	S3	Weight g/1 piece	Order code*	PN (bar) ¹⁾		
											CF	A3C	MS
S ⁴⁾	38	14	10	52	44.0	62	60	27	575	KOR38/14SOMD	315	315	200
	38	16	12	52	43.5	62	60	30	580	KOR38/16SOMD	315	315	200
	38	20	16	54	43.5	65	60	36	593	KOR38/20SOMD	315	315	200
	38	25	20	56	44.0	68	60	46	605	KOR38/25SOMD	315	315	200
	38	30	25	58	44.5	71	60	50	614	KOR38/30SOMD	315	315	200

¹⁾ Pressure shown = item deliverable

⁴⁾ S = heavy series

$$\frac{\text{PN (bar)}}{10} = \text{PN (MPa)}$$

Delivery without nut and ring. Information on ordering complete fittings see page I7.

*Please add the **suffixes** below according to the material/surface required.

Order code suffixes		
Material	Suffix surface and material	Example
Steel, zinc plated, chrome ⁶ -free	CF	KOR16/10SOMDCF
Steel, zinc yellow plated	A3C	KOR16/10SOMDA3C
Brass	MS	KOR16/10SOMDMS

KOR Tube end reducer – Stainless steel

EO stand pipe adjustable / EO 24° cone end

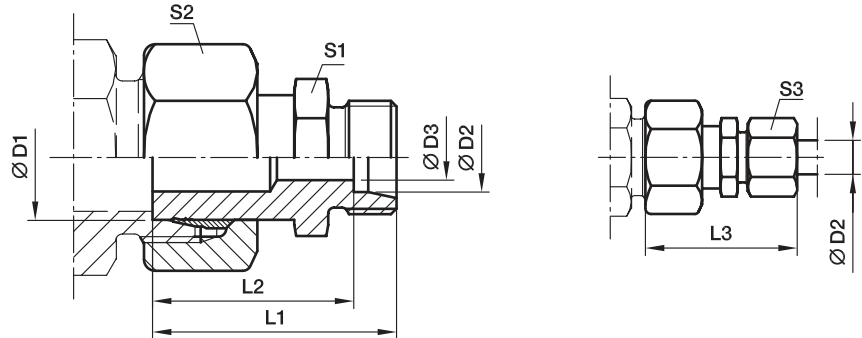

With pre-assembled nut and progressive ring for connection.
Final assembly (in appropriate body) at least 1/4 turn beyond the point of clearly perceptible resistance.

Series	D1	D2	D3	L1	L2	L3	S1	S2	S3	Weight g/1 piece	Order code	PN (bar) ¹⁾
												71
L ³⁾	08	06	4	33.5	26.5	41	12	17	14	32	KOR08/06LOMD71	315
	10	06	4	34.5	27.5	42	12	19	14	39	KOR10/06LOMD71	315
	10	08	6	35.5	28.5	43	14	19	17	40	KOR10/08LOMD71	315
	12	06	4	36.5	29.5	44	14	22	14	49	KOR12/06LOMD71	315
	12	08	6	36.5	29.5	44	14	22	17	53	KOR12/08LOMD71	315
	12	10	8	37.5	30.5	45	17	22	19	55	KOR12/10LOMD71	315
	15	06	4	37.0	30.0	45	17	27	14	79	KOR15/06LOMD71	315
	15	08	6	37.0	30.0	45	17	27	17	78	KOR15/08LOMD71	315
	15	10	8	38.0	31.0	46	17	27	19	85	KOR15/10LOMD71	315
	15	12	10	39.0	32.0	47	19	27	22	84	KOR15/12LOMD71	315
	18	06	4	37.5	30.5	45	19	32	14	112	KOR18/06LOMD71	315
	18	08	6	37.5	30.5	45	19	32	17	113	KOR18/08LOMD71	315
	18	10	8	38.5	31.5	46	19	32	19	113	KOR18/10LOMD71	315
	18	12	10	38.5	31.5	46	19	32	22	122	KOR18/12LOMD71	315
	18	15	12	39.5	32.5	48	24	32	27	131	KOR18/15LOMD71	315
	22	06	4	38.5	31.5	46	24	36	14	154	KOR22/06LOMD71	160
	22	08	6	38.5	31.5	46	24	36	17	155	KOR22/08LOMD71	160
	22	10	8	39.5	32.5	47	24	36	19	156	KOR22/10LOMD71	160
	22	12	10	39.5	32.5	47	24	36	22	157	KOR22/12LOMD71	160
	22	15	12	40.5	33.5	49	24	36	27	160	KOR22/15LOMD71	160
22	18	15	41.5	34.0	50	27	36	32	173	KOR22/18LOMD71	160	
28	06	4	41.0	34.0	49	30	41	14	220	KOR28/06LOMD71	160	
28	08	6	41.0	34.0	49	30	41	17	217	KOR28/08LOMD71	160	
28	10	8	42.0	35.0	50	30	41	19	211	KOR28/10LOMD71	160	
28	12	10	42.0	35.0	50	30	41	22	219	KOR28/12LOMD71	160	
28	15	12	43.0	36.0	51	30	41	27	188	KOR28/15LOMD71	160	
28	18	15	43.0	35.5	52	30	41	32	218	KOR28/18LOMD71	160	
28	22	19	45.0	37.5	54	32	41	36	228	KOR28/22LOMD71	160	
35	06	4	48.5	41.5	56	36	50	14	307	KOR35/06LOMD71	160	
35	08	6	48.5	41.5	56	36	50	17	313	KOR35/08LOMD71	160	
35	10	8	49.5	42.5	57	36	50	19	370	KOR35/10LOMD71	160	
35	12	10	49.5	42.5	57	36	50	22	371	KOR35/12LOMD71	160	
35	15	12	50.5	43.5	59	36	50	27	380	KOR35/15LOMD71	160	
35	18	15	50.5	43.0	59	36	50	32	382	KOR35/18LOMD71	160	
35	22	19	52.5	45.0	61	36	50	36	380	KOR35/22LOMD71	160	
35	28	24	52.5	45.0	62	41	50	41	400	KOR35/28LOMD71	160	
42	10	8	52.5	45.5	60	46	60	19	551	KOR42/10LOMD71	160	
42	12	10	52.5	45.5	60	46	60	22	551	KOR42/12LOMD71	160	
42	15	12	53.5	46.5	62	46	60	27	687	KOR42/15LOMD71	160	
42	18	15	53.5	46.0	62	46	60	32	555	KOR42/18LOMD71	160	
42	22	19	55.5	48.0	64	46	60	36	568	KOR42/22LOMD71	160	
42	28	24	55.5	48.0	65	46	60	41	559	KOR42/28LOMD71	160	
42	35	30	57.5	47.0	69	46	60	50	588	KOR42/35LOMD71	160	

¹⁾ Pressure shown = item deliverable

³⁾ L = light series

$$\frac{\text{PN (bar)}}{10} = \text{PN (MPa)}$$

Delivery without nut and ring. Information on ordering complete fittings see page 17.

KOR Tube end reducer – Stainless steel

EO stand pipe adjustable / EO 24° cone end

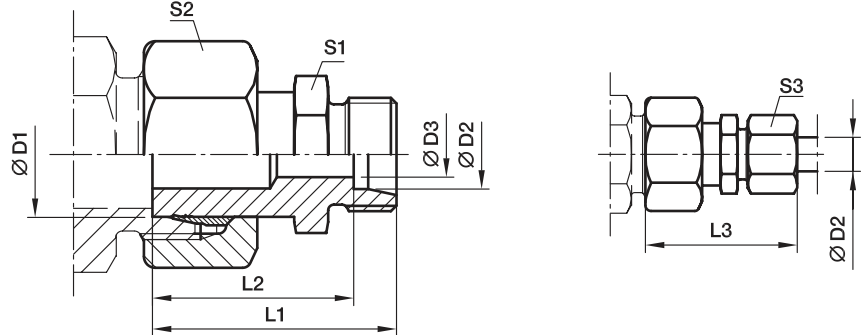

With pre-assembled nut and progressive ring for connection.
Final assembly (in appropriate body) at least 1/4 turn beyond the point of clearly perceptible resistance.

Series	D1	D2	D3	L1	L2	L3	S1	S2	S3	Weight g/1 piece	Order code	PN (bar) ¹⁾	
												71	
S ⁴⁾	08	06	4	36.5	29.5	44	14	19	17	16	KOR08/06SOMD71	630	
	10	06	4	38.5	31.5	46	14	22	17	16	KOR10/06SOMD71	630	
	10	08	5	38.5	31.5	46	17	22	19	14	KOR10/08SOMD71	630	
	12	06	4	38.5	31.5	46	14	24	17	16	KOR12/06SOMD71	630	
	12	08	5	38.5	31.5	46	17	24	19	16	KOR12/08SOMD71	630	
	12	10	7	39.5	32.0	48	19	24	22	27	KOR12/10SOMD71	630	
	14	06	4	40.5	33.5	48	17	27	17	32	KOR14/06SOMD71	630	
	14	08	5	40.5	33.5	48	17	27	19	34	KOR14/08SOMD71	630	
	14	10	7	41.5	34.0	50	19	27	22	35	KOR14/10SOMD71	630	
	14	12	8	41.5	34.0	50	22	27	24	41	KOR14/10SOMD71	630	
	16	06	4	41.0	34.0	49	17	30	17	44	KOR16/06SOMD71	400	
	16	08	5	41.0	34.0	49	17	30	19	45	KOR16/08SOMD71	400	
	16	10	7	42.0	34.5	51	19	30	22	46	KOR16/10SOMD71	400	
	16	12	8	42.0	34.5	51	22	30	24	68	KOR16/12SOMD71	400	
	16	14	10	44.0	36.0	54	24	30	27	69	KOR16/14SOMD71	400	
	20	06	4	46.0	39.0	54	22	36	17	70	KOR20/06SOMD71	400	
	20	08	5	46.0	39.0	54	22	36	19	70	KOR20/08SOMD71	400	
	20	10	7	46.0	38.5	55	22	36	22	100	KOR20/10SOMD71	400	
	20	12	8	46.0	38.5	55	22	36	24	101	KOR20/12SOMD71	400	
	20	14	10	48.0	40.0	58	24	36	27	101	KOR20/14SOMD71	400	
20	16	12	49.0	40.5	59	27	36	30	101	KOR20/16SOMD71	400		
25	06	4	50.5	43.5	58	27	46	17	106	KOR25/06SOMD71	400		
25	08	5	50.5	43.5	58	27	46	19	136	KOR25/08SOMD71	400		
25	10	7	50.5	43.0	59	27	46	22	136	KOR25/10SOMD71	400		
25	12	8	50.5	43.0	59	27	46	24	138	KOR25/12SOMD71	400		
25	14	10	52.5	44.5	62	27	46	27	138	KOR25/14SOMD71	400		
25	16	12	52.5	44.0	62	27	46	30	143	KOR25/16SOMD71	400		
25	20	16	54.5	44.0	66	32	46	36	143	KOR25/20SOMD71	400		
30	06	4	53.0	46.0	61	32	50	17	177	KOR30/06SOMD71	400		
30	08	5	53.0	46.0	61	32	50	19	179	KOR30/08SOMD71	400		
30	10	7	53.0	45.5	62	32	50	22	180	KOR30/10SOMD71	400		
30	12	8	53.0	45.5	62	32	50	24	180	KOR30/12SOMD71	400		
30	14	10	55.0	47.0	65	32	50	27	185	KOR30/14SOMD71	400		
30	16	12	55.0	46.5	65	32	50	30	184	KOR30/16SOMD71	400		
30	20	16	57.0	46.5	68	32	50	36	188	KOR30/20SOMD71	400		
30	25	20	60.0	48.0	72	41	50	46	302	KOR30/25SOMD71	400		
38	06	4	60.0	53.0	68	41	60	17	306	KOR38/06SOMD71	315		
38	08	5	60.0	53.0	68	41	60	19	305	KOR38/08SOMD71	315		
38	10	7	60.0	52.5	69	41	60	22	304	KOR38/10SOMD71	315		
38	12	8	60.0	52.5	69	41	60	24	308	KOR38/12SOMD71	315		
38	14	10	62.0	54.0	72	41	60	27	316	KOR38/14SOMD71	315		
38	16	12	62.0	53.5	72	41	60	30	310	KOR38/16SOMD71	315		
38	20	16	64.0	53.5	75	41	60	36	305	KOR38/20SOMD71	315		
38	25	20	66.0	54.0	78	41	60	46	455	KOR38/25SOMD71	315		
38	30	25	69.0	55.5	82	46	60	50	438	KOR38/30SOMD71	315		

¹⁾ Pressure shown = item deliverable

⁴⁾ S = heavy series

Delivery without nut and ring. Information on ordering complete fittings see page 17.

$$\frac{\text{PN (bar)}}{10} = \text{PN (MPa)}$$

GZ Swivel union

EO 24° DKO swivel

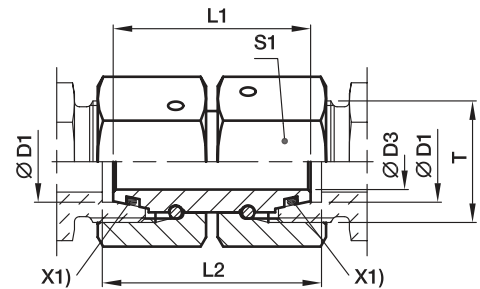

X1) O-ring OR

Series	D1 	D3	L1	L2	S1	Weight g/1 piece	Order code*	PN (bar) ¹⁾		
								CF	A3C	71
L ³⁾	06	2.5	32	33	14	28	GZ06L	500	315	315
	08	4.0	32	33	17	41	GZ08L	500	315	315
	10	6.0	33	34	19	53	GZ10L	500	315	315
	12	8.0	33	34	22	71	GZ12L	400	315	315
	15	10.0	38	39	27	129	GZ15L	400	315	315
	18	13.0	36	38	32	165	GZ18L	400	315	315
	22	17.0	42	44	36	243	GZ22L	250	160	160
	28	22.0	46	48	41	319	GZ28L	250	160	160
	35	28.0	48	52	50	449	GZ35L	250	160	160
	42	34.0	52	57	60	737	GZ42L	250	160	160
S ⁴⁾	06	2.5	32	33	17	41	GZ06S	800	630	630
	08	4.0	33	34	19	54	GZ08S	800	630	630
	10	6.0	33	35	22	74	GZ10S	800	630	630
	12	8.0	36	38	24	95	GZ12S	630	630	630
	14	9.0	39	41	27	131	GZ14S	630	630	630
	16	11.0	39	42	30	172	GZ16S	630	400	400
	20	14.0	44	48	36	261	GZ20S	420	400	400
	25	18.0	46	53	46	477	GZ25S	420	400	400
	30	23.0	52	62	50	605	GZ30S	420	400	400
	38	30.0	52	67	60	826	GZ38S	420	315	315

¹⁾ Pressure shown = item deliverable

³⁾ L = light series; ⁴⁾ S = heavy series

$$\frac{PN \text{ (bar)}}{10} = PN \text{ (MPa)}$$

Information on ordering complete fittings or alternative sealing materials see page I7.

Order code suffixes			
Material	Suffix surface and material	Example	Standard sealing material (no additional suffix needed)
Steel, zinc plated, chrome ⁶⁾ -free	CF	GZ16SCF	NBR
Steel, zinc yellow plated	A3C	GZ16SA3C	NBR
Stainless Steel	71	GZ16S71	VIT

*Please add the **suffixes** below according to the material/surface required.

GZR Swivel reducer

EO 24° DKO swivel

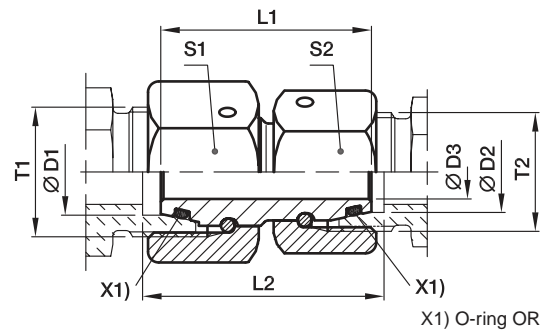

Series 3) 4)	D1	D2	T1	T2	D3	L1	L2	S1	S2	Weight g/1 piece	Order code*	PN (bar) ¹⁾	
												CF	A3C
L/S	06	06	M 14 1.5	M 12 1.5	2.5	32	33.0	17	14	34	GZR06L/06S	500	315
L	08	06	M 14 1.5	M 12 1.5	2.5	32	33.0	17	14	36	GZR08/06L	500	315
L/S	08	08	M 16 1.5	M 14 1.5	4.0	33	34.0	19	17	48	GZR08L/08S	500	315
L	10	06	M 16 1.5	M 12 1.5	2.5	33	34.0	19	14	44	GZR10/06L	500	315
L	10	08	M 16 1.5	M 14 1.5	4.0	33	34.0	19	17	50	GZR10/08L	500	315
L/S	10	10	M 18 1.5	M 16 1.5	6.0	33	34.5	22	19	63	GZR10L/10S	500	315
L	12	06	M 18 1.5	M 12 1.5	2.5	33	34.0	22	14	56	GZR12/06L	400	315
L	12	08	M 18 1.5	M 14 1.5	4.0	33	34.0	22	17	62	GZR12/08L	400	315
L	12	10	M 18 1.5	M 16 1.5	6.0	33	34.0	22	19	65	GZR12/10L	400	315
L/S	12	12	M 20 1.5	M 18 1.5	8.0	36	37.5	24	22	85	GZR12L/12S	400	315
L	15	08	M 22 1.5	M 14 1.5	4.0	38	39.0	27	17	98	GZR15/08L	400	315
L	15	10	M 22 1.5	M 16 1.5	6.0	38	39.0	27	19	101	GZR15/10L	400	315
L	15	12	M 22 1.5	M 18 1.5	8.0	38	39.0	27	22	108	GZR15/12L	400	315
L	18	10	M 26 1.5	M 16 1.5	6.0	36	37.5	32	19	125	GZR18/10L	400	315
L	18	12	M 26 1.5	M 18 1.5	8.0	36	37.5	32	22	132	GZR18/12L	400	315
L	18	15	M 26 1.5	M 22 1.5	10.0	38	39.5	32	27	155	GZR18/15L	400	315
L/S	18	16	M 26 1.5	M 24 1.5	11.0	39	41.5	32	30	177	GZR18L/16S	400	315
L	22	12	M 30 2	M 18 1.5	8.0	42	43.5	36	22	195	GZR22/12L	250	160
L	22	15	M 30x2	M 22 1.5	10.0	42	43.5	36	27	215	GZR22/15L	250	160
L	22	18	M 30 2	M 26 1.5	13.0	42	44.0	36	32	228	GZR22/18L	250	160
L/S	22	20	M 30 2	M 30 2	14.0	44	47.0	36	36	266	GZR22L/20S	250	160
L	28	15	M 36 2	M 22 1.5	10.0	46	47.5	41	27	143	GZR28/15L	250	160
L	28	18	M 36 2	M 26 1.5	13.0	46	48.0	41	32	311	GZR28/18L	250	160
L	28	22	M 36 2	M 30 2	17.0	46	46.0	41	36	309	GZR28/22L	250	160
L/S	28	25	M 36 2	M 36 2	18.0	46	50.5	41	46	419	GZR28L/25S	250	160
L	35	18	M 45 2	M 26 1.5	13.0	48	51.0	50	32	430	GZR35/18L	250	160
L	35	22	M 45 2	M 30 2	17.0	48	51.0	50	36	429	GZR35/22L	250	160
L	35	28	M 45 2	M 36 2	22.0	48	51.0	50	41	415	GZR35/28L	250	160
L/S	35	30	M 45 2	M 42 2	23.0	52	59.0	50	50	577	GZR35L/30S	250	160
L	42	22	M 52 2	M 30 2	17.0	52	55.5	60	36	653	GZR42/22L	250	160
L	42	28	M 52 2	M 36 2	22.0	52	55.5	60	41	648	GZR42/28L	250	160
L	42	35	M 52 2	M 45 2	28.0	52	56.5	60	50	662	GZR42/35L	250	160
L/S	42	38	M 52 2	M 52 2	30.0	52	62.0	60	60	822	GZR42L/38S	250	160
S	08	06	M 16 1.5	M 14 1.5	2.5	33	34.0	19	17	49	GZR08/06S	800	630
S	10	06	M 18 1.5	M 14 1.5	2.5	33	34.5	22	17	60	GZR10/06S	800	630
S	10	08	M 18 1.5	M 16 1.5	4.0	33	34.5	22	19	66	GZR10/08S	800	630
S	12	06	M 20 1.5	M 14 1.5	2.5	36	37.5	24	17	77	GZR12/06S	630	630
S	12	08	M 20 1.5	M 16 1.5	4.0	36	37.5	24	19	82	GZR12/08S	630	630
S	12	10	M 20 1.5	M 18 1.5	6.0	36	38.0	24	22	89	GZR12/10S	630	630
S	16	10	M 24 1.5	M 18 1.5	6.0	39	41.5	30	22	138	GZR16/10S	630	400
S	16	12	M 24 1.5	M 20 1.5	8.0	39	41.5	30	24	143	GZR16/12S	630	400
S/L	16	15	M 24 1.5	M 22 1.5	10.0	39	41.0	30	27	153	GZR16S/15L	400	315
S	20	12	M 30 2	M 20 1.5	8.0	44	47.0	36	24	204	GZR20/12S	420	400

GZR Swivel reducer

EO 24° DKO swivel

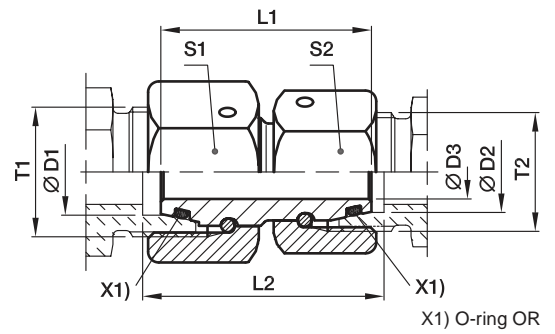

Series 3) 4)	D1	D2	T1	T2	D3	L1	L2	S1	S2	Weight g/1 piece	Order code*	PN (bar) ¹⁾	
												CF	A3C
S	20	16	M 30 2	M 24 1.5	11.0	44	47.5	36	30	232	GZR20/16S	420	400
S/L	20	18	M 30 2	M 26 1.5	13.0	44	47.0	36	32	224	GZR20S/18L	400	315
S	25	16	M 36 2	M 24 1.5	11.0	46	51.0	46	30	224	GZR25/16S	420	400
S	25	20	M 36 2	M 30 2	14.0	46	51.5	46	36	364	GZR25/20S	420	400
S/L	25	22	M 36 2	M 30 2	17.0	46	50.5	46	36	475	GZR25S/22L	250	160
S	30	16	M 42 2	M 24 1.5	11.0	52	58.5	50	30	475	GZR30/16S	420	400
S	30	20	M 42 2	M 30 2	14.0	52	59.0	50	36	500	GZR30/20S	420	400
S	30	25	M 42 2	M 36 2	18.0	52	60.5	50	46	589	GZR30/25S	420	400
S/L	30	28	M 42 2	M 36 2	22.0	52	58.0	50	41	476	GZR30S/28L	250	160
S	38	20	M 52 2	M 30 2	14.0	52	61.5	60	36	671	GZR38/20S	420	315
S	38	25	M 52 2	M 36 2	18.0	52	63.0	60	46	759	GZR38/25S	420	315
S	38	30	M 52 2	M 42 2	23.0	52	64.5	60	50	767	GZR38/30S	420	315
S/L	38	35	M 52 2	M 45 2	28.0	52	61.5	60	50	662	GZR38S/35L	250	160

¹⁾ Pressure shown = item deliverable

³⁾ L = light series; ⁴⁾ S = heavy series

$$\frac{\text{PN (bar)}}{10} = \text{PN (MPa)}$$

Information on ordering complete fittings or alternative sealing materials see page 17.

*Please add the **suffixes** below according to the material/surface required.

Order code suffixes			
Material	Suffix surface and material	Example	Standard sealing material (no additional suffix needed)
Steel, zinc plated, chrome ⁶ -free	CF	GZR16/12SCF	NBR
Steel, zinc yellow plated	A3C	GZR16/12SA3C	NBR

GEO Male stud connector

Male metric thread – O-ring (ISO 6149) / EO 24° cone end

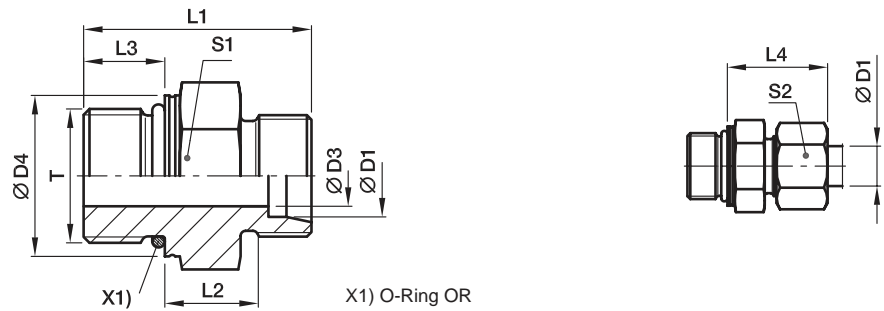

Series	D1	T	D3	D4	L1	L2	L3	L4	S1	S2	Weight g/1 piece	Order code*	PN (bar) ¹⁾		
													CF	A3C	71
LL ²⁾	04	M 08 1	3.0	10.8	20.0	9.5	6.5	19.0	11	10	8	GEO04LLMOMD	100	100	
	04	M 10 1	3.0	12.8	20.0	9.5	6.5	19.0	13	10	11	GEO04LLM10X1OMD	100	100	
	06	M 10 1	4.5	12.8	20.0	8.0	6.5	19.5	13	12	10	GEO06LLMOMD	100	100	
L ³⁾	06	M 10 1	4.5	14.0	24.0	8.5	8.5	23.0	14	14	15	GEO06LMOMD	500	315	315
	08	M 12 1.5	6.0	17.0	28.0	10.0	11.0	25.0	17	17	23	GEO08LMOMD	500	315	315
	10	M 14 1.5	7.5	19.0	29.0	11.0	11.0	26.0	19	19	28	GEO10LMOMD	500	315	315
	12	M 16 1.5	9.0	22.0	31.0	12.5	11.5	27.0	22	22	40	GEO12LMOMD	400	315	315
	15	M 18 1.5	11.0	24.0	33.0	13.5	12.5	29.0	24	27	56	GEO15LMOMD	400	315	315
	18	M 22 1.5	14.0	27.0	35.0	14.5	13.0	31.0	27	32	80	GEO18LMOMD	400	315	315
	22	M 27 2	18.0	32.0	40.0	16.5	16.0	33.0	32	36	104	GEO22LM27X2OMD	250	160	160
	28	M 33 2	23.0	41.0	41.0	17.5	16.0	34.0	41	41	171	GEO28LMOMD	250	160	160
	35	M 42 2	30.0	50.0	44.0	17.5	16.0	39.0	50	50	278	GEO35LMOMD	250	160	160
	42	M 48 2	36.0	55.0	47.5	19.0	17.5	42.0	55	60	340	GEO42LMOMD	250	160	160
S ⁴⁾	06	M 12 1.5	4.0	17.0	31.0	13.0	11.0	28.0	17	17	29	GEO06SMOMD	800	630	630
	08	M 14 1.5	6.0	19.0	33.0	15.0	11.0	30.0	19	19	41	GEO08SMOMD	800	630	630
	10	M 16 1.5	7.0	22.0	35.0	15.0	12.5	31.0	22	22	55	GEO10SMOMD	800	630	630
	12	M 18 1.5	9.0	24.0	38.5	17.0	14.0	33.0	24	24	73	GEO12SMOMD	630	630	630
	16	M 22 1.5	12.0	27.0	42.0	18.5	15.0	37.0	27	30	102	GEO16SMOMD	630	400	400
	20	M 27 2	15.0	32.0	49.5	20.5	18.5	42.0	32	36	169	GEO20SMOMD	420	400	400
	25	M 33 2	20.0	41.0	53.5	23.0	18.5	47.0	41	46	274	GEO25SMOMD	420	400	400
	30	M 42 2	26.0	50.0	56.0	23.5	19.0	50.0	50	50	412	GEO30SMOMD	420	400	400
	38	M 48 2	32.0	55.0	63.5	26.0	21.5	57.0	55	60	580	GEO38SMOMD	420	315	315

¹⁾ Pressure shown = item deliverable

²⁾ LL = very light series; ³⁾ L = light series; ⁴⁾ S = heavy series

$$\frac{PN \text{ (bar)}}{10} = PN \text{ (MPa)}$$

Delivery without nut and ring. Information on ordering complete fittings or alternative sealing materials see page 17.

*Please add the **suffixes** below according to the material/surface required.

Order code suffixes			
Material	Suffix surface and material	Example	Standard sealing material (no additional suffix needed)
Steel, zinc plated, chrome ⁶⁾ -free	CF	GEO16SMOMDCF	NBR
Steel, zinc yellow plated	A3C	GEO16SMOMDA3C	NBR
Stainless Steel	71	GEO16SMOMD71	VIT

GE-M-ED Male stud connector

Male metric thread – ED (ISO 9974) / EO 24° cone end

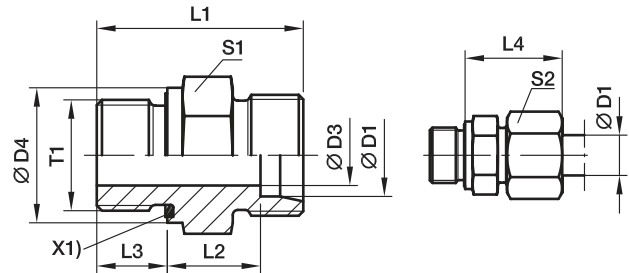

X1) Eolastic-sealing ED

Series	D1	T1	D3	D4	L1	L2	L3	L4	S1	S2	Weight g/1 piece	Order code*	PN (bar) ¹⁾			
													CF	A3C	71	
L ³⁾	06	M10 1	4	14	23.5	8.5	8	23	14	14	13	GE06LMEDOMD	500	315	315	
	08	M12 1.5	6	17	29.0	10.0	12	25	17	17	22	GE08LMEDOMD	500	315	315	
	10	M14 1.5	7	19	30.0	11.0	12	26	19	19	29	GE10LMEDOMD	500	315	315	
	10	M12 1.5	6	17	30.0	11.0	12	26	17	19	23	GE10LM12X1.5EDOMD	315	315	315	
	10	M16 1.5	8	22	31.5	12.5	12	24	22	19	40	GE10LM16X1.5EDOMD	400	315	315	
	10	M18 1.5	8	24	31.5	12.5	12	27	24	19	50	GE10LM18X1.5EDOMD	400	315	315	
	10	M22 1.5	8	27	35.0	14.0	14	29	27	19	80	GE10LM22X1.5EDOMD	400	315	315	
	12	M16 1.5	9	22	31.5	12.5	12	27	22	22	40	GE12LMEDOMD	400	315	315	
	12	M14 1.5	7	19	30.0	11.0	12	26	19	22	30	GE12LM14X1.5EDOMD	400	315	315	
	12	M18 1.5	10	24	31.5	12.5	12	27	24	22	47	GE12LM18X1.5EDOMD	400	315	315	
	12	M22 1.5	10	27	35.0	14.0	14	29	27	22	75	GE12LM22X1.5EDOMD	400	315	315	
	15	M18 1.5	11	24	32.5	13.5	12	29	24	27	51	GE15LMEDOMD	400	315	315	
	15	M16 1.5	9	22	32.0	13.0	12	28	24	27	64	GE15LM16X1.5EDOMD	400	315	315	
	15	M22 1.5	12	27	36.0	15.0	14	30	27	27	77	GE15LM22X1.5EDOMD	400	315	315	
	18	M22 1.5	14	27	36.0	14.5	14	31	27	32	74	GE18LMEDOMD	400	315	315	
	S ⁴⁾	18	M18 1.5	11	24	33.5	14.0	12	30	27	32	68	GE18LM18X1.5EDOMD	400	315	315
		22	M26 1.5	18	32	40.0	16.5	16	33	32	36	103	GE22LMEDOMD	250	160	160
		22	M22 1.5	14	32	38.0	16.5	14	33	32	36	97	GE22LM22X1.5EDOMD	250	160	160
28		M33 2	23	40	43.0	17.5	18	34	41	41	168	GE28LMEDOMD	250	160	160	
35		M42 2	30	50	48.0	17.5	20	39	50	50	281	GE35LMEDOMD	250	160	160	
42		M48 2	36	55	52.0	19.0	22	42	55	60	356	GE42LMEDOMD	250	160	160	
06		M12 1.5	4	17	32.0	13.0	12	28	17	17	30	GE06SMEDOMD	800	630	630	
08		M14 1.5	5	19	34.0	15.0	12	30	19	19	42	GE08SMEDOMD	800	630	630	
10		M16 1.5	7	22	34.5	15.0	12	31	22	22	54	GE10SMEDOMD	800	630	630	
12		M18 1.5	8	24	36.5	17.0	12	33	24	24	71	GE12SMEDOMD	630	630	630	
12		M14 1.5	5	19	36.0	16.5	12	33	22	24	60	GE12SM14X1.5EDOMD	630	630	630	
12		M22 1.5	8	27	39.0	17.5	14	34	27	24	102	GE12SM22X1.5EDOMD	630	400	400	
14	M20 1.5	10	26	41.0	19.0	14	37	27	27	98	GE14SMEDOMD	630	630	630		
16	M22 1.5	12	27	41.0	18.5	14	37	27	30	95	GE16SMEDOMD	630	400	400		
16	M18 1.5	8	24	38.5	18.0	12	36	27	30	88	GE16SM18X1.5EDOMD	630	400	400		
20	M27 2	16	32	47.0	20.5	16	42	32	36	150	GE20SMEDOMD	420	400	400		
25	M33 2	20	40	53.0	23.0	18	47	41	46	264	GE25SMEDOMD	420	400	400		
30	M42 2	25	50	57.0	23.5	20	50	50	50	422	GE30SMEDOMD	420	400	400		
38	M48 2	32	55	64.0	26.0	22	57	55	60	569	GE38SMEDOMD	420	315	315		

¹⁾ Pressure shown = item deliverable

³⁾ L = light series; ⁴⁾ S = heavy series

$$\frac{\text{PN (bar)}}{10} = \text{PN (MPa)}$$

Delivery without nut and ring. Information on ordering complete fittings or alternative sealing materials see page 17.

*Please add the **suffixes** below according to the material/surface required.

Order code suffixes			
Material	Suffix surface and material	Example	Standard sealing material (no additional suffix needed)
Steel, zinc plated, chrome ⁶⁾ -free	CF	GE16SMEDOMDCF	NBR
Steel, zinc yellow plated	A3C	GE16SMEDOMDA3C	NBR
Stainless Steel	71	GE16SMEDOMD71	VIT

GE-R-ED Male stud connector

Male BSPP thread – ED-seal (ISO 1179) / EO 24° cone end

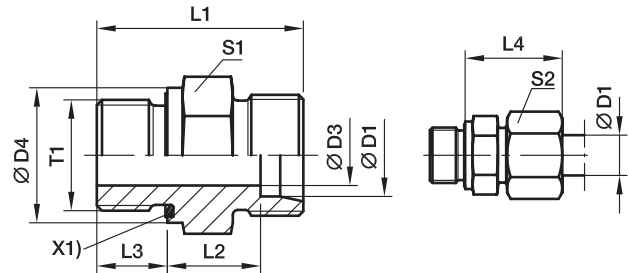

X1) Eolastic-sealing ED

Series	D1	T1	D3	D4	L1	L2	L3	L4	S1	S2	Weight g/1 piece	Order code*	PN (bar) ¹⁾			
													CF	A3C	71	MS
LL ²⁾	04	G1/8A	3	14	20.0	9.5	6.5	19	14	10	10	GE04LLREDOMD	100	100	100	63
	06	G1/8A	4	14	20.0	8.0	6.5	20	14	12	11	GE06LLREDOMD	100	100	100	63
L ³⁾	06	G1/8A	4	14	23.5	8.5	8.0	23	14	14	13	GE06LREDOMD	500	315	315	200
	06	G1/4A	4	19	29.0	10.0	12.0	25	19	14	28	GE06LR1/4EDOMD	500	315	315	200
	06	G3/8A	4	22	30.5	11.5	12.0	26	22	14	44	GE06LR3/8EDOMD	400	315	315	200
	06	G1/2A	4	27	33.0	12.0	14.0	27	27	14	61	GE06LR1/2EDOMD	400	315	315	200
	08	G1/4A	6	19	29.0	10.0	12.0	25	19	17	27	GE08LREDOMD	500	315	315	200
	08	G1/8A	4	14	24.5	9.5	8.0	24	14	17	16	GE08LR1/8EDOMD	500	315	315	200
	08	G3/8A	6	22	30.5	11.5	12.0	26	22	17	45	GE08LR3/8EDOMD	400	315	315	200
	08	G1/2A	6	27	33.0	12.0	14.0	27	27	17	74	GE08LR1/2EDOMD	400	315	315	200
	10	G1/4A	6	19	30.0	11.0	12.0	26	19	19	29	GE10LREDOMD	500	315	315	200
	10	G1/8A	4	14	25.5	10.5	8.0	25	17	19	21	GE10LR1/8EDOMD	500	315	315	200
	10	G3/8A	8	22	31.5	12.5	12.0	27	22	19	43	GE10LR3/8EDOMD	400	315	315	200
	10	G1/2A	8	27	34.0	13.0	14.0	28	27	19	71	GE10LR1/2EDOMD	400	315	315	200
	12	G3/8A	9	22	31.5	12.5	12.0	27	22	22	41	GE12LREDOMD	400	315	315	200
	12	G1/8A	4	14	26.5	11.5	8.0	26	19	22	26	GE12LR1/8EDOMD	315	315	315	200
	12	G1/4A	6	19	31.0	12.0	12.0	27	19	22	31	GE12LR1/4EDOMD	400	315	315	200
	12	G1/2A	10	27	34.0	13.0	14.0	28	27	22	67	GE12LR1/2EDOMD	400	315	315	200
	12	G3/4A	10	32	37.0	14.0	16.0	29	32	22	118	GE12LR3/4EDOMD	250	160	160	100
	15	G1/2A	11	27	35.0	14.0	14.0	29	27	27	72	GE15LREDOMD	400	315	315	200
	15	G3/8A	9	22	32.5	13.5	12.0	29	24	27	54	GE15LR3/8EDOMD	400	315	315	200
	15	G3/4A	12	32	38.0	15.0	16.0	30	32	27	116	GE15LR3/4EDOMD	250	160	160	100
	18	G1/2A	14	27	36.0	14.5	14.0	31	27	32	71	GE18LREDOMD	400	315	315	200
	18	G3/8A	9	22	33.5	14.0	12.0	30	27	32	66	GE18LR3/8EDOMD	400	315	315	200
	18	G3/4A	15	32	38.0	14.5	16.0	31	32	32	110	GE18LR3/4EDOMD	250	160	160	100
	22	G3/4A	18	32	40.0	16.5	16.0	33	32	36	102	GE22LREDOMD	250	160	160	100
	22	G1/2A	14	27	38.0	16.5	14.0	33	32	36	91	GE22LR1/2EDOMD	250	160	160	100
	22	G1A	19	40	43.0	17.5	18.0	34	41	36	189	GE22LR1EDOMD	250	160	160	100
	28	G1A	23	40	43.0	17.5	18.0	34	41	41	170	GE28LREDOMD	250	160	160	100
	28	G3/4A	18	32	41.0	17.5	16.0	34	41	41	159	GE28LR3/4EDOMD	250	160	160	100
	28	G11/4A	24	50	46.0	18.5	20.0	35	50	41	316	GE28LR11/4EDOMD	250	160	160	100
	35	G11/4A	30	50	48.0	17.5	20.0	39	50	50	272	GE35LREDOMD	250	160	160	100
	35	G1A	23	40	46.0	17.5	18.0	39	46	50	226	GE35LR1EDOMD	250	160	160	100
	35	G11/2A	30	55	52.0	19.5	22.0	41	55	50	423	GE35LR11/2EDOMD	250	160	160	100
	42	G11/2A	36	55	52.0	19.0	22.0	42	55	60	343	GE42LREDOMD	250	160	160	100
	42	G1A	23	40	48.0	19.0	18.0	42	55	60	324	GE42LR1EDOMD	250	160	160	100
	42	G11/4A	30	50	50.0	19.0	20.0	42	55	60	348	GE42LR11/4EDOMD	250	160	160	100

1) Pressure shown = item deliverable

2) LL = very light series; 3) L = light series

$$\frac{PN(\text{bar})}{10} = PN(\text{MPa})$$

Delivery without nut and ring. Information on ordering complete fittings or alternative sealing materials see page 17.

 *Please add the **suffixes** below according to the material/surface required.

Order code suffixes			
Material	Suffix surface and material	Example	Standard sealing material (no additional suffix needed)
Steel, zinc plated, chrome ²⁾ -free	CF	GE18LREDOMDCF	NBR
Stahl, zinc yellow plated	A3C	GE18LREDOMDA3C	NBR
Stainless Steel	71	GE18LREDOMD71	VIT
Brass	MS	GE18LREDOMDMS	NBR

GE-R-ED Male stud connector

Male BSPP thread – ED-seal (ISO 1179) / EO 24° cone end

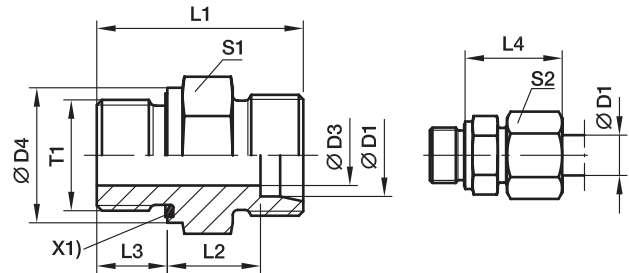

X1) Eolastic-sealing ED

Series	D1	T1	D3	D4	L1	L2	L3	L4	S1	S2	Weight g/1 piece	Order code*	PN (bar) ¹⁾			
													CF	A3C	71	MS
S ⁴⁾	06	G1/4A	4	19	32.0	13.0	12	28	19	17	35	GE06SREDOMD	800	630	630	400
	06	G1/8A	4	14	27.5	12.5	8	27	14	17	21	GE06SR1/8EDOMD	315	315	315	
	06	G3/8A	4	22	34.5	15.5	12	30	22	17	52	GE06SR3/8EDOMD	630	630	630	
	06	G1/2A	4	27	39.0	18.0	14	33	27	17	83	GE06SR1/2EDOMD	630	630	630	
	08	G1/4A	5	19	34.0	15.0	12	30	19	19	41	GE08SREDOMD	800	630	630	400
	08	G3/8A	5	22	34.5	15.5	12	30	22	19	57	GE08SR3/8EDOMD	800	630	630	
	08	G1/2A	5	27	39.0	18.0	14	33	27	19	89	GE08SR1/2EDOMD	630	400	400	
	10	G3/8A	7	22	34.5	15.0	12	31	22	22	55	GE10SREDOMD	800	630	630	400
	10	G1/4A	5	19	34.0	14.5	12	31	19	22	42	GE10SR1/4EDOMD	800	630	630	
	10	G1/2A	7	27	39.0	17.5	14	34	27	22	97	GE10SR1/2EDOMD	630	630	630	
	12	G3/8A	8	22	36.5	17.0	12	33	22	24	62	GE12SREDOMD	630	630	630	400
	12	G1/4A	5	19	36.0	16.5	12	33	22	24	61	GE12SR1/4EDOMD	630	630	630	
	12	G1/2A	8	27	39.0	17.5	14	34	27	24	99	GE12SR1/2EDOMD	630	630	630	
	14	G1/2A	10	27	41.0	19.0	14	37	27	27	96	GE14SREDOMD	630	630	630	400
	14	G3/8A	8	22	38.5	18.5	12	36	24	27	74	GE14SR3/8EDOMD	630	630	630	
	14	G3/4A	10	32	45.0	21.0	16	39	32	27	138	GE14SR3/4EDOMD	400	400	400	
	16	G1/2A	12	27	41.0	18.5	14	37	27	30	91	GE16SREDOMD	630	400	400	250
	16	G3/8A	8	22	38.5	18.0	12	36	27	30	83	GE16SR3/8EDOMD	630	400	400	
	16	G3/4A	12	27	45.0	20.5	16	39	32	30	152	GE16SR3/4EDOMD	420	400	400	
	20	G3/4A	16	32	47.0	20.5	16	42	32	36	149	GE20SREDOMD	420	400	400	250
20	G1/2A	12	27	45.0	20.5	14	42	32	36	142	GE20SR1/2EDOMD	420	400	400		
20	G1A	16	40	51.0	22.5	18	44	41	36	265	GE20SR1EDOMD	420	400	400		
20	G11/4A	16	50	53.0	22.5	20	44	50	36	404	GE20SR11/4EDOMD	400	400	400		
25	G1A	20	40	53.0	23.0	18	47	41	46	266	GE25SREDOMD	420	400	400	250	
25	G1/2A	12	27	49.0	23.0	14	47	41	46	228	GE25SR1/2EDOMD	420	400	400		
25	G3/4A	16	32	51.0	23.0	16	47	41	46	255	GE25SR3/4EDOMD	420	400	400		
25	G11/4A	20	50	55.0	23.0	20	47	50	46	411	GE25SR11/4EDOMD	400	400	400		
25	G11/2A	20	55	60.0	26.0	22	50	55	46	549	GE25SR11/2EDOMD	315	315	315		
30	G11/4A	25	50	57.0	23.5	20	50	50	50	418	GE30SREDOMD	420	400	400	250	
30	G1A	20	40	55.0	23.5	18	50	46	50	344	GE30SR1EDOMD	420	400	400		
30	G11/2A	25	55	62.0	26.5	22	53	55	50	530	GE30SR11/2EDOMD	315	315	315		
38	G11/2A	32	55	64.0	26.0	22	57	55	60	563	GE38SREDOMD	420	315	315	200	
38	G11/4A	25	50	62.0	26.0	20	57	55	60	575	GE38SR11/4EDOMD	420	315	315		

¹⁾ Pressure shown = item deliverable

⁴⁾ S = heavy series

$\frac{PN \text{ (bar)}}{10} = PN \text{ (MPa)}$

Delivery without nut and ring. Information on ordering complete fittings or alternative sealing materials see page 17.

*Please add the suffixes below according to the material/surface required.

Order code suffixes			
Material	Suffix surface and material	Example	Standard sealing material (no additional suffix needed)
Steel, zinc plated, chrome ⁶ -free	CF	GE16SREDOMDCF	NBR
Stahl, zinc yellow plated	A3C	GE16SREDOMDA3C	NBR
Stainless Steel	71	GE16SREDOMD71	VIT
Brass	MS	GE16SREDOMDMS	NBR

GE-R Male stud connector

Male BSPP thread – metal sealing edge (ISO 1179) / EO 24° cone end

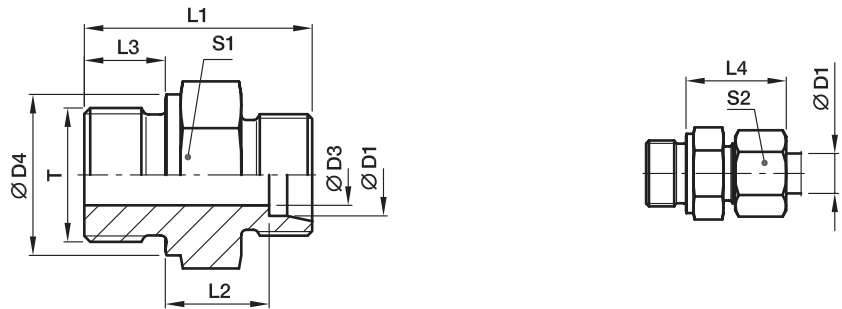

Series	D1	T	D3	D4	L1	L2	L3	L4	S1	S2	Weight g/1 piece	Order code*	PN (bar) ¹⁾			
													CF	A3C	71	MS
L ³⁾	06	G1/8A	4	14	23.5	8.5	8	23.0	14	14	14	GE06LR	315	315	315	200
	06	G1/4A	4	18	29.0	10.0	12	25.0	19	14	60	GE06LR1/4	315	315	315	200
	06	G3/8A	4	22	30.5	11.5	12	26.0	22	14	45	GE06LR3/8	315	315	315	200
	06	G1/2A	4	26	33.0	12.0	14	27.0	27	14	60	GE06LR1/2	315	315	315	200
	08	G1/4A	6	18	29.0	10.0	12	25.0	19	17	26	GE08LR	315	315	315	200
	08	G1/8A	4	14	24.5	8.5	8	23.0	14	17	16	GE08LR1/8	315	315	315	200
	08	G3/8A	6	22	30.5	11.5	12	26.0	22	17	44	GE08LR3/8	315	315	315	200
	08	G1/2A	6	26	33.0	12.0	14	27.0	27	17	74	GE08LR1/2	315	315	315	200
	10	G1/4A	6	18	30.0	11.0	12	26.0	19	19	31	GE10LR	315	315	315	200
	10	G1/8A	4	14	25.5	10.5	8	25.0	17	19	21	GE10LR1/8	315	315	315	200
10	G3/8A	8	22	31.5	12.5	12	27.0	22	19	44	GE10LR3/8	315	315	315	200	
10	G1/2A	8	26	34.0	13.0	14	28.0	27	19	72	GE10LR1/2	315	315	315	200	
12	G3/8A	9	22	31.5	12.5	12	27.0	22	22	43	GE12LR	315	315	315	200	
12	G1/8A	4	14	26.5	11.5	8	26.0	19	22	27	GE12LR1/8	315	315	315	200	
12	G1/4A	6	18	31.0	12.0	12	27.0	19	22	32	GE12LR1/4	315	315	315	200	
12	G1/2A	10	26	34.0	13.0	14	28.0	27	22	67	GE12LR1/2	315	315	315	200	
12	G3/4A	10	32	37.0	14.0	16	29.0	32	22	120	GE12LR3/4	315	315	315	200	
15	G1/2A	11	26	35.0	14.0	14	29.0	27	27	72	GE15LR	250	250	250	160	
15	G3/8A	9	22	32.5	13.5	12	29.0	24	27	56	GE15LR3/8	250	250	250	160	
15	G3/4A	12	32	38.0	15.0	16	30.0	32	27	118	GE15LR3/4	250	250	250	160	
18	G1/2A	14	26	36.0	14.5	14	31.0	27	32	72	GE18LR	250	250	250	160	
18	G3/8A	9	22	33.5	14.0	12	29.5	27	32	69	GE18LR3/8	250	250	250	160	
18	G3/4A	15	32	38.0	14.5	16	30.0	32	32	112	GE18LR3/4	250	250	250	160	
22	G3/4A	18	32	40.0	16.5	16	33.0	32	36	103	GE22LR	160	160	160	100	
22	G1/2A	14	26	38.0	16.5	14	33.0	32	36	91	GE22LR1/2	160	160	160	100	
22	G1A	19	39	43.0	17.5	18	33.5	41	36	184	GE22LR1	160	160	160	100	
28	G1A	23	39	43.0	17.5	18	34.0	41	41	168	GE28LR	160	160	160	100	
28	G1/2A	14	26	39.0	17.5	14	34.0	41	41	141	GE28LR1/2	160	160	160	100	
28	G3/4A	18	32	41.0	17.5	16	34.0	41	41	156	GE28LR3/4	160	160	160	100	
28	G11/4A	24	50	46.0	18.3	20	35.0	50	41	314	GE28LR11/4	160	160	160	100	
35	G11/4A	30	49	48.0	17.5	20	39.0	50	50	276	GE35LR	160	160	160	100	
35	G1/2A	14	26	42.0	17.5	14	39.0	46	50	194	GE35LR1/2	160	160	160	100	
35	G3/4A	18	32	44.0	17.5	16	39.0	46	50	202	GE35LR3/4	160	160	160	100	
35	G1A	23	39	46.0	17.5	18	39.0	46	50	234	GE35LR1	160	160	160	100	
35	G11/2A	30	55	52.0	19.5	22	41.0	55	50	355	GE35LR11/2	160	160	160	100	
42	G11/2A	36	55	52.0	19.0	22	42.0	55	60	349	GE42LR	160	160	160	100	
42	G1A	23	39	48.0	19.0	18	42.0	55	60	327	GE42LR1	160	160	160	100	
42	G11/4A	30	49	50.0	19.0	20	42.0	55	60	336	GE42LR11/4	160	160	160	100	

¹⁾ Pressure shown = item deliverable

³⁾ L = light series

$$\frac{\text{PN (bar)}}{10} = \text{PN (MPa)}$$

Delivery without nut and ring. Information on ordering complete fittings see page I7.

*Please add the suffixes below according to the material/surface required.

Order code suffixes		
Material	Suffix surface and material	Example
Steel, zinc plated, chrome ⁶ -free	CFX	GE18LR CFX
Steel, zinc yellow plated	A3CX	GE18LR A3CX
Stainless Steel	71X	GE18LR 71X
Brass	MSX	GE18LR MSX

GE-R Male stud connector

Male BSPP thread – metal sealing edge (ISO 1179) / EO 24° cone end

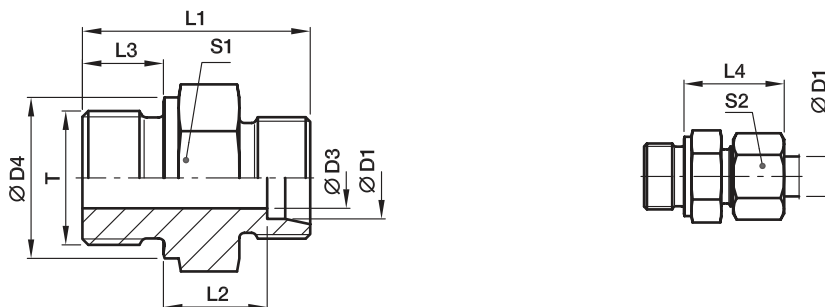

Series	D1	T	D3	D4	L1	L2	L3	L4	S1	S2	Weight g/1 piece	Order code*	PN (bar) ¹⁾			
													CF	A3C	71	MS
S ⁴⁾	06	G1/4A	4	18	32.0	13.0	12	28	19	17	35	GE06SR	400	400	400	250
	06	G1/8A	3	14	27.5	12.5	8	27	14	17	22	GE06SR1/8	400	400	400	
	06	G3/8A	4	22	34.5	15.5	12	30	22	17	57	GE06SR3/8	400	400	400	
	06	G1/2A	4	26	39.0	18.0	14	33	27	17	83	GE06SR1/2	400	400	400	
	08	G1/4A	5	18	34.0	15.0	12	30	19	19	41	GE08SR	400	400	400	250
	08	G3/8A	5	22	34.5	15.5	12	30	22	19	59	GE08SR3/8	400	400	400	
	08	G1/2A	5	26	39.0	18.0	14	33	27	19	100	GE08SR1/2	400	400	400	250
	10	G3/8A	7	22	34.5	15.0	12	31	22	22	56	GE10SR	400	400	400	
	10	G1/4A	5	18	34.0	14.5	12	31	19	22	43	GE10SR1/4	400	400	400	
	10	G1/2A	7	26	39.0	17.5	14	34	27	22	97	GE10SR1/2	400	400	400	
	12	G3/8A	8	22	36.5	17.0	12	33	22	24	62	GE12SR	400	400	400	250
	12	G1/4A	5	18	36.0	16.5	12	33	22	24	57	GE12SR1/4	400	400	400	
	12	G1/2A	8	26	39.0	17.5	14	34	27	24	57	GE12SR1/2	400	400	400	250
	14	G1/2A	10	26	41.0	19.0	14	37	27	27	96	GE14SR	400	400	400	
	14	G3/8A	8	22	38.5	18.5	12	36	24	27	74	GE14SR3/8	400	400	400	
	16	G1/2A	12	26	41.0	18.5	14	37	27	30	92	GE16SR	400	400	400	
	16	G3/8A	8	22	38.5	18.0	12	36	27	30	83	GE16SR3/8	400	400	400	250
	16	G3/4A	12	32	45.0	20.5	16	39	32	30	157	GE16SR3/4	400	400	400	
	20	G3/4A	16	32	47.0	20.5	16	42	32	36	151	GE20SR	400	400	400	250
	20	G1/2A	12	26	45.0	20.5	14	42	32	36	142	GE20SR1/2	400	400	400	
20	G1A	16	39	51.0	22.5	18	44	41	36	273	GE20SR1	250	250	250	160	
20	G11/4A	16	49	53.0	22.5	20	44	50	36	387	GE20SR11/4	160	160	160		
25	G1A	20	39	53.0	23.0	18	47	41	46	267	GE25SR	250	250	250		
25	G3/4A	16	32	51.0	23.0	16	47	41	46	245	GE25SR3/4	250	250	250		
25	G11/4A	20	49	55.0	23.0	20	47	50	46	422	GE25SR11/4	160	160	160		
30	G11/4A	25	49	57.0	23.5	20	50	50	50	422	GE30SR	160	160	160	100	
30	G1A	20	39	55.0	23.5	18	50	46	50	337	GE30SR1	160	160	160		
38	G11/2A	32	55	64.0	26.0	22	57	55	60	560	GE38SR	160	160	160	100	
38	G11/4A	25	49	62.0	26.0	20	57	55	60	578	GE38SR11/4	160	160	160		

1) Pressure shown = item deliverable

4) S = heavy series

$$\frac{PN \text{ (bar)}}{10} = PN \text{ (MPa)}$$

Delivery without nut and ring. Information on ordering complete fittings see page I7.

*Please add the **suffixes** below according to the material/surface required.

Order code suffixes		
Material	Suffix surface and material	Example
Steel, zinc plated, chrome ⁶ -free	CFX	GE16SRCFX
Steel, zinc yellow plated	A3CX	GE16SRA3CX
Stainless Steel	71X	GE16SR71X
Brass	MSX	GE16SRMSX

GE-R(KEG) Male stud connector

Male short BSP taper thread (DIN 3852-2, type C) / EO 24° cone end

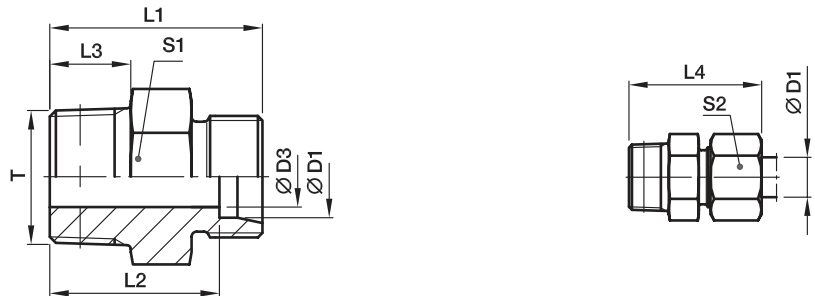

Series	D1	T	D3	L1	L2	L3	L4	S1	S2	Weight g/1 piece	Order code*	PN (bar) ¹⁾			
												CF	A3C	71	MS
LL ²⁾	04	R1/8tap.	3.0	20	16.0	8	26	11	10	8	GE04LLR	100	100	100	63
	06	R1/8tap.	4.5	20	14.5	8	26	11	12	8	GE06LLR	100	100	100	63
	08	R1/8tap.	6.0	22	16.5	8	28	12	14	10	GE08LLR	100	100	100	63
	08	R1/4tap.	6.0	26	20.5	12	32	14	14	18	GE08LLR1/4	100	100	100	63
	10	R1/4tap.	8.0	26	20.5	12	32	14	17	15	GE10LLR	100	100		63
	12	R1/4tap.	8.0	26	20.0	12	32	17	19	18	GE12LLR	100	100		63
	12	R3/8tap.	10.0	26	20.0	12	32	17	19	23	GE12LLR3/8	100	100		63
	L ³⁾	06	R1/8tap.	4.0	22	15.0	8	30	12	14	11	GE06LR1/8KEG	315	315	315
06		R1/4tap.	4.0	27	20.0	12	35	17	14	24	GE06LR1/4KEG	315	315	315	200
08		R1/8tap.	4.0	23	16.0	8	31	17	17	15	GE08LR1/8KEG	315	315	315	200
08		R1/4tap.	6.0	27	20.0	12	35	17	17	22	GE08LR1/4KEG	315	315	315	
10		R1/4tap.	7.0	28	21.0	12	36	17	19	24	GE10LR1/4KEG	315	315	315	
12		R1/4tap.	7.0	29	22.0	12	37	19	22	53	GE12LR1/4KEG	315	315	315	200
12		R3/8tap.	9.0	29	22.0	12	37	19	22	33	GE12LR3/8KEG	315	315	315	
12		R1/2tap.	10.0	31	24.0	14	39	24	22	53	GE12LR1/2KEG	315	315	315	200
15		R3/8tap.	9.0	30	23.0	12	38	24	27	49	GE15LR3/8KEG	315	315	315	200
15		R1/2tap.	11.0	32	25.0	14	40	24	27	59	GE15LR1/2KEG	315	315	315	
18		R1/2tap.	14.0	33	25.5	14	42	27	32	64	GE18LR1/2KEG	315	315	315	
22		R3/4tap.	17.0	37	29.5	16	46	32	36	99	GE22LR3/4KEG	160	160	160	
28		R1tap.	23.0	40	32.5	18	49	41	41	154	GE28LR1KEG	160	160	160	
35		R1 1/4tap.	30.0	45	34.5	20	56	46	50	238	GE35LR11/4KEG	160	160	160	
42	R1 1/2tap.	36.0	49	38.0	22	61	55	60	335	GE42LR11/2KEG	160	160	160		

¹⁾ Pressure shown = item deliverable

²⁾ LL = very light series; ³⁾ L = light series

$$\frac{\text{PN (bar)}}{10} = \text{PN (MPa)}$$

Delivery without nut and ring. Information on ordering complete fittings see page 17.

*Please add the **suffixes** below according to the material/surface required.

Order code suffixes		
Material	Suffix surface and material	Example
Steel, zinc plated, chrome ⁶ -free	CFX	GE06LR1/4KEGCFX
Steel, zinc yellow plated	A3CX	GE06LR1/4KEGA3CX
Stainless Steel	71X	GE06LR1/4KEG71X
Brass	MSX	GE06LR1/4KEGMSX

GE-M Male stud connector

Male metric thread – metal sealing edge (ISO 9974) / EO 24° cone end

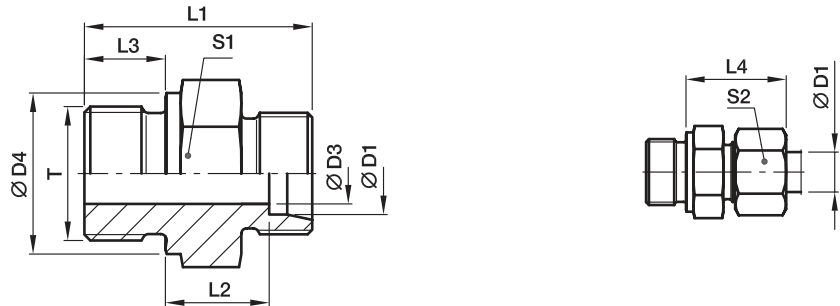

Series	D1	T	D3	D4	L1	L2	L3	L4	S1	S2	Weight g/1 piece	Order code*	PN (bar) ¹⁾			
													CF	A3C	71	MS
L ³⁾	06	M10 1	4	14	23.5	8.5	8	23	14	14	13	GE06LM	315	315	315	200
	08	M12 1.5	6	17	29.0	10.0	12	25	17	17	22	GE08LM	315	315	315	200
	10	M14 1.5	7	19	30.0	11.0	12	26	19	19	31	GE10LM	315	315	315	200
	10	M10 1	4	14	25.5	10.5	8	25	17	19	20	GE10LM10X1	315	315	315	
	10	M12 1.5	6	17	30.0	11.0	12	26	17	19	25	GE10LM12X1.5	315	315	315	
	10	M16 1.5	8	21	31.5	12.0	12	27	22	19	41	GE10LM16X1.5	315	315	315	
	10	M18 1.5	8	23	31.5	12.5	12	27	24	19	50	GE10LM18X1.5	315	315	315	
	10	M22 1.5	8	27	35.0	14.0	14	29	27	19	72	GE10LM22X1.5	315	315	315	
	12	M14 1.5	7	19	30.0	11.0	12	26	19	22	30	GE12LM14X1.5	315	315	315	
	12	M16 1.5	9	21	31.5	12.5	12	27	22	22	40	GE12LMA3C	315	315	315	
	12	M18 1.5	10	23	31.5	12.5	12	27	24	22	47	GE12LM18X1.5	315	315	315	
	12	M22 1.5	10	27	31.5	14.0	14	29	27	22	76	GE12LM22X1.5	315	315	315	
	15	M16 1.5	9	21	32.0	13.0	12	28	24	27	50	GE15LM16X1.5	250	250	250	
	15	M18 1.5	11	23	32.5	13.5	12	29	24	27	52	GE15LM	250	250	250	160
	15	M22 1.5	12	27	36.0	15.0	14	30	27	27	77	GE15LM22X1.5	250	250	250	
	18	M18 1.5	11	23	33.5	14.0	12	30	27	32	68	GE18LM18X1.5	250	250	250	
	18	M22 1.5	14	27	36.0	14.5	14	31	27	32	77	GE18LM	250	250	250	160
	22	M22 1.5	14	27	38.0	16.5	14	33	32	36	92	GE22LM22X1.5	160	160	160	
	22	M26 1.5	18	31	40.0	16.5	16	33	32	36	102	GE22LM	160	160	160	100
	28	M33 2	23	39	43.0	17.5	18	34	41	41	168	GE28LM	160	160	160	100
35	M42 2	30	49	48.0	17.5	20	39	50	50	280	GE35LM	160	160	160	100	
42	M48 2	36	55	52.0	19.0	22	42	55	60	354	GE42LM	160	160	160	100	
S ⁴⁾	06	M12 1.5	4	17	32.0	13.0	12	28	17	17	30	GE06SM	400	400	400	250
	06	M14 1.5	4	19	34.0	15.0	12	30	19	17	42	GE06SM14X1.5	400	400	400	
	08	M14 1.5	5	19	34.0	15.0	12	30	19	19	43	GE08SM	400	400	400	250
	10	M16 1.5	7	21	34.5	15.0	12	31	22	22	54	GE10SM	400	400	400	250
	12	M18 1.5	8	23	36.5	17.0	12	33	24	24	72	GE12SM	400	400	400	250
	12	M14 1.5	5	19	36.0	16.5	12	33	22	24	60	GE12SM14X1.5	400	400	400	
	12	M22 1.5	8	27	39.0	17.5	14	34	27	24	103	GE12SM22X1.5	400	400	400	
	14	M20 1.5	10	25	41.0	19.0	14	37	27	27	95	GE14SM	400	400	400	250
	16	M18 1.5	8	23	38.5	18.0	12	36	27	30	88	GE16SM18X1.5	400	400	400	
	16	M22 1.5	12	27	41.0	18.5	14	37	27	30	97	GE16SM	400	400	400	250
	20	M27 2	16	32	47.0	20.5	16	42	32	36	155	GE20SM	400	400	400	250
	25	M33 2	20	39	53.0	23.0	18	47	41	46	268	GE25SM	250	250	250	160
	30	M42 2	25	49	57.0	23.5	20	50	50	50	421	GE30SM	160	160	160	100
	38	M48 2	32	55	64.0	26.0	22	57	55	60	568	GE38SM	160	160	160	100

¹⁾ Pressure shown = item deliverable

³⁾ L = light series; ⁴⁾ S = heavy series

$$\frac{\text{PN (bar)}}{10} = \text{PN (MPa)}$$

Delivery without nut and ring. Information on ordering complete fittings see page I7.

*Please add the **suffixes** below according to the material/surface required.

Order code suffixes		
Material	Suffix surface and material	Example
Steel, zinc plated, chrome ⁶ -free	CFX	GE16SMCFX
Steel, zinc yellow plated	A3CX	GE16SMA3CX
Stainless Steel	71X	GE16SM71X
Brass	MSX	GE16SMMSX

GE-M(KEG) Male stud connector

Male short metric taper thread (DIN 3852-1, type C) / EO 24° cone end

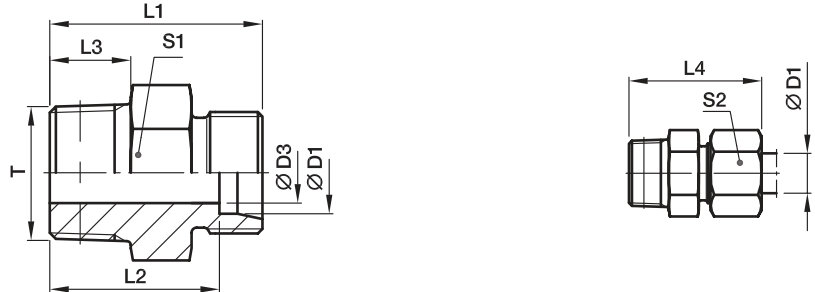

Series	D1	T	D3	L1	L2	L3	L4	S1	S2	Weight g/1 piece	Order code*	PN (bar) ¹⁾			
												CF	A3C	71	MS
LL ²⁾	04	M6 1tap.	2.0	20	16.0	8	26	9	10	5	GE04LLM6X1KEG	100	100		
	04	M8 1tap.	3.0	20	16.0	8	26	10	10	7	GE04LLM	100	100	100	63
	06	M10 1tap.	4.5	20	14.5	8	26	11	12	9	GE06LLM	100	100	100	63
	06	M8 1tap.	3.5	20	14.5	8	26	11	12	9	GE06LLM8X1KEG	100	100		
	08	M10 1tap.	6.0	22	16.5	8	28	12	14	10	GE08LLM	100	100	100	63

¹⁾ Pressure shown = item deliverable

²⁾ LL = very light series

$$\frac{\text{PN (bar)}}{10} = \text{PN (MPa)}$$

Delivery without nut and ring. Information on ordering complete fittings see page I7.

Order code suffixes		
Material	Suffix surface and material	Example
Steel, zinc plated, chrome ⁶ -free	CFX	GE06LLMCFX
Steel, zinc yellow plated	A3CX	GE06LLMA3CX
Stainless Steel	71X	GE06LLM71X
Brass	MSX	GE06LLMMSX

*Please add the **suffixes** below according to the material/surface required.

GE-UNF/UN Male stud connector

Male UNF/UN thread – O-ring (ISO 11926) / EO 24° cone end

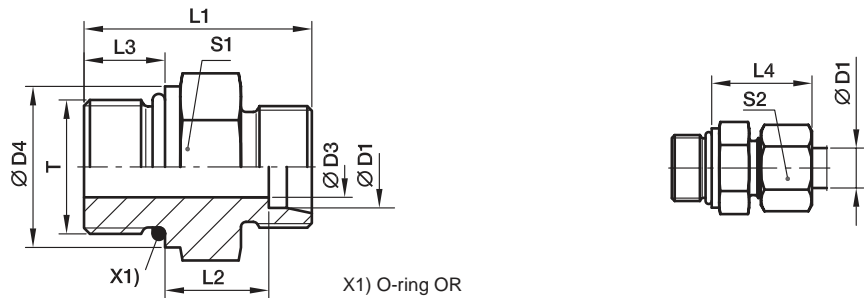

Series	D1	T	D3	D4	L1	L2	L3	L4	S1	S2	Weight g/1 piece	Order code*	PN (bar) ¹⁾		
													CF	A3C	71
L ³⁾	08	7/16-20UNF-2A	5.0	14.4	26	10.0	9.0	25	17	17	21	GE08L7/16UNFOMD	315	315	315
	10	7/16-20UNF-2A	5.0	14.4	27	11.0	10.0	26	17	19	23	GE10L7/16UNFOMD	315	315	315
	12	9/16-18UNF-2A	7.0	17.6	28	11.0	10.0	26	19	22	32	GE12L9/16UNFOMD	315	315	315
	12	3/4-16UNF-2A	10.0	22.3	31	13.0	11.0	28	24	22	52	GE12L3/4UNFOMD	315	315	315
	12	7/8-14UNF-2A	10.0	25.5	34	14.3	12.7	29	27	22	77	GE12L7/8UNFOMD	315	315	315
	15	3/4-16UNF-2A	11.0	22.3	32	14.0	11.0	29	24	27	57	GE15L3/4UNFOMD	315	315	315
	15	7/8-14UNF-2A	12.0	25.5	35	15.3	12.7	30	27	27	81	GE15L7/8UNFOMD	315	315	315
	18	3/4-16UNF-2A	11.0	22.3	33	14.5	11.0	31	27	32	68	GE18L3/4UNFOMD	315	315	315
	18	7/8-14UNF-2A	14.0	25.5	35	14.8	12.7	31	27	32	72	GE18L7/8UNFOMD	315	315	315
	22	7/8-14UNF-2A	14.0	25.5	37	16.8	12.7	33	32	36	94	GE22L7/8UNFOMD	160	160	160
	22	11/16-12UN-2A	18.0	31.9	39	16.5	15.0	33	32	36	103	GE22L11/16UNOMD	160	160	160
	22	15/16-12UN-2A	19.0	38.2	40	17.5	15.0	34	41	36	163	GE22L15/16UNOMD	160	160	160
	28	11/16-12UN-2A	18.0	31.9	40	17.5	15.0	34	41	41	152	GE28L11/16UNOMD	160	160	160
	28	15/16-12UN-2A	23.0	38.2	40	17.5	15.0	34	41	41	163	GE28L15/16UNOMD	160	160	160
	35	15/16-12UN-2A	23.0	38.2	43	17.5	15.0	39	46	50	222	GE35L15/16UNOMD	160	160	160
	35	15/8-12UN-2A	29.0	47.7	43	17.5	15.0	39	50	50	257	GE35L15/8UNOMD	160	160	160
42	15/8-12UN-2A	29.0	47.7	45	19.0	15.0	42	55	60	339	GE42L15/8UNOMD	160	160	160	
S ⁴⁾	08	7/16-20UNF-2A	4.0	16.0	31	15.0	9.0	30	17	19	33	GE08S7/16UNFOMD	630	630	630
	10	9/16-18UNF-2A	6.0	17.6	32	14.5	10.0	31	19	22	42	GE10S9/16UNFOMD	630	630	630
	12	9/16-18UNF-2A	6.0	17.6	32	14.5	10.0	31	22	24	50	GE12S9/16UNFOMD	630	630	630
	12	3/4-16UNF-2A	8.0	22.3	36	17.5	11.0	34	24	24	73	GE12S3/4UNFOMD	630	630	630
	16	3/4-16UNF-2A	10.5	22.3	35	15.5	11.0	34	24	30	90	GE16S3/4UNFOMD	400	400	400
	16	7/8-14UNF-2A	12.0	25.5	40	18.8	12.7	37	27	30	95	GE16S7/8UNFOMD	400	400	400
	20	3/4-16UNF-2A	10.0	22.3	42	20.5	11.0	42	32	36	132	GE20S3/4UNFOMD	400	400	400
	20	7/8-14UNF-2A	12.0	25.5	44	20.8	12.7	42	32	36	141	GE20S7/8UNFOMD	400	400	400
	20	11/16-12UN-2A	16.0	31.9	46	20.5	15.0	42	32	36	163	GE20S11/16UNOMD	400	400	400
	25	11/16-12UN-2A	16.0	31.9	50	23.0	15.0	47	36	46	206	GE25S11/16UNOMD	400	400	400
	25	15/16-12UN-2A	20.0	38.2	50	23.0	15.0	47	41	46	258	GE25S15/16UNOMD	400	400	400
	30	15/16-12UN-2A	20.0	38.2	52	23.5	15.0	50	46	50	327	GE30S15/16UNOMD	400	400	400
	30	15/8-12UN-2A	24.0	47.7	52	23.5	15.0	50	50	50	422	GE30S15/8UNOMD	400	400	400
	38	15/8-12UN-2A	24.0	47.7	57	26.0	15.0	57	55	60	554	GE38S15/8UNOMD	315	315	315

¹⁾ Pressure shown = item deliverable

³⁾ L = light series; ⁴⁾ S = heavy series

$$\frac{\text{PN (bar)}}{10} = \text{PN (MPa)}$$

Delivery without nut and ring. Information on ordering complete fittings or alternative sealing materials see page 17.

*Please add the **suffixes** below according to the material/surface required.

Order code suffixes			
Material	Suffix surface and material	Example	Standard sealing material (no additional suffix needed)
Steel, zinc plated, chrome ⁶⁾ -free	CF	GE16S3/4UNFOMDCF	NBR
Steel, zinc yellow plated	A3C	GE16S3/4UNFOMDA3C	NBR
Stainless Steel	71	GE16S3/4UNFOMD71	VIT

GE-NPT Male stud connector

Male NPT thread (SAE J476) / EO 24° cone end

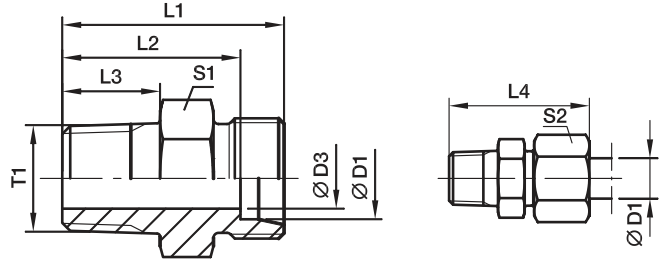

Series	D1	T1	D3	L1	L2	L3	L4	S1	S2	Weight g/1 piece	Order code*	PN (bar) ¹⁾			
												CF	A3C	71	MS
LL ²⁾	04	1/8-27 NPT	3.0	22.0	18.0	10.0	28	11	10	9	GE04LL1/8NPT	100	100	100	
	06	1/8-27 NPT	4.5	22.0	16.5	10.0	28	11	12	9	GE06LL1/8NPT	100	100	100	63
	08	1/8-27 NPT	5.0	24.0	18.5	10.0	30	12	14	11	GE08LL1/8NPT	100	100	100	63
L ³⁾	06	1/8-27 NPT	4.0	24.0	17.0	10.0	32	12	14	12	GE06L1/8NPT	315	315	315	200
	06	1/4-18 NPT	4.0	30.0	23.0	14.5	38	17	14	27	GE06L1/4NPT	315	315	315	200
	06	3/8-18 NPT	4.0	30.0	23.0	14.5	38	19	14	32	GE06L3/8NPT	315	315	315	
	06	1/2-14 NPT	4.0	36.0	29.0	19.5	44	22	14	53	GE06L1/2NPT	315	315	315	
	08	1/8-27 NPT	4.0	25.0	18.0	10.0	33	14	17	16	GE08L1/8NPT	315	315	315	
	08	1/4-18 NPT	6.0	30.0	23.0	14.5	38	17	17	25	GE08L1/4NPT	315	315	315	200
	08	3/8-18 NPT	6.0	30.0	23.0	14.5	38	19	17	34	GE08L3/8NPT	315	315	315	
	08	1/2-14 NPT	6.0	36.0	29.0	19.5	44	22	17	54	GE08L1/2NPT	315	315	315	
	10	1/8-27 NPT	4.0	25.0	18.0	10.0	33	17	19	19	GE10L1/8NPT	315	315	315	
	10	1/4-18 NPT	7.0	31.0	24.0	14.5	39	17	19	25	GE10L1/4NPT	315	315	315	200
	10	3/8-18 NPT	7.0	32.0	25.0	14.5	40	19	19	40	GE10L3/8NPT	315	315	315	
	10	1/2-14 NPT	8.0	37.0	30.0	19.5	45	22	19	54	GE10L1/2NPT	315	315	315	
	10	3/4-14 NPT	8.0	38.0	31.0	19.5	46	30	19	93	GE10L3/4NPT	315	315	315	
	12	1/8-27NPT	4.0	26.0	19.0	10.0	34	19	22	52	GE12L1/8NPT	315	315	315	
	12	1/4-18 NPT	7.0	32.0	25.0	14.5	40	19	22	31	GE12L1/4NPT	315	315	315	200
	12	3/8-18 NPT	8.0	32.0	25.0	14.5	40	19	22	37	GE12L3/8NPT	315	315	315	200
	12	1/2-14 NPT	10.0	37.0	30.0	19.5	45	22	22	62	GE12L1/2NPT	315	315	315	200
	15	3/8-18 NPT	8.0	33.0	26.0	14.5	41	24	27	53	GE15L3/8NPT	315	315	315	
	15	1/2-14 NPT	12.0	38.0	31.0	19.5	46	24	27	63	GE15L1/2NPT	315	315	315	200
	15	3/4-14 NPT	12.0	39.0	32.0	19.5	47	30	27	112	GE15L3/4NPT	315	315	315	
	15	1-11 1/2 NPT	12.0	45.0	38.0	24.5	53	36	27	158	GE15L1NPT	315	315	315	
	18	3/8-18 NPT	8.0	34.0	26.5	14.5	43	27	32	69	GE18L3/8NPT	315	315	315	
	18	1/2-14 NPT	12.0	39.0	31.5	19.5	48	27	32	79	GE18L1/2NPT	315	315	315	200
	18	3/4-14 NPT	15.0	39.0	31.5	19.5	48	30	32	104	GE18L3/4NPT	315	315	315	
	18	1-11 1/2 NPT	15.0	45.0	37.5	24.5	54	36	32	159	GE18L1NPT	315	315	315	
	22	3/8-18 NPT	8.0	36.5	29.0	14.5	45	32	36	91	GE22L3/8NPT	160	160	160	
	22	1/2-14 NPT	12.0	41.0	33.5	19.5	50	32	36	96	GE22L1/2NPT	160	160	160	
	22	3/4-14 NPT	16.0	41.0	33.5	19.5	50	32	36	108	GE22L3/4NPT	160	160	160	100
	22	1-11 1/2 NPT	19.0	47.0	39.5	24.5	56	36	36	174	GE22L1NPT	160	160	160	
	28	3/4-14 NPT	16.0	42.0	34.5	19.5	51	41	41	157	GE28L3/4NPT	160	160	160	
28	1-11 1/2 NPT	21.0	47.0	39.5	24.5	56	41	41	197	GE28L1NPT	160	160	160	100	
28	11/4-1 11/2 NPT	24.0	49.0	41.5	25.0	48	46	41	266	GE28L11/4NPT	160	160	160		
35	1-11 1/2NPT	22.0	50.0	39.5	24.5	61	46	50	280	GE35L1NPT	160	160	160		
35	11/4-11 1/2 NPT	28.0	51.0	40.5	25.0	62	46	50	285	GE35L11/4NPT	160	160	160		
42	11/4- 11 1/2 NPT	28.0	53.0	42.0	25.0	65	55	60	382	GE42L11/4NPT	160	160	160		
42	11/2-11 1/2 NPT	36.0	53.0	42.0	26.0	65	55	60	377	GE42L11/2NPT	160	160	160		

¹⁾ Pressure shown = item deliverable

²⁾ LL = very light series; ³⁾ L = light series

$$\frac{\text{PN (bar)}}{10} = \text{PN (MPa)}$$

Delivery without nut and ring. Information on ordering complete fittings see page 17.

*Please add the suffixes below according to the material/surface required.

Order code suffixes		
Material	Suffix surface and material	Example
Steel, zinc plated, chrome ⁶ -free	CFX	GE18L1/2NPTCFX
Steel, zinc yellow plated	A3CX	GE18L1/2NPTA3CX
Stainless Steel	71X	GE18L1/2NPT71X
Brass	MSX	GE18L1/2NPTMSX

GE-NPT Male stud connector

Male NPT thread (SAE J476) / EO 24° cone end

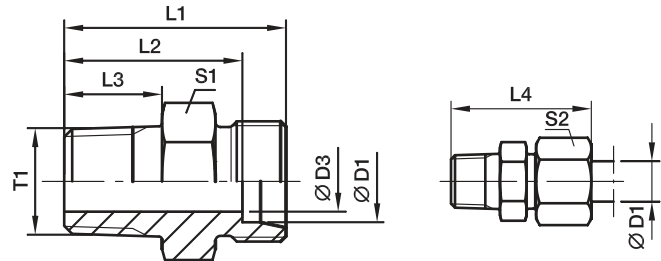

Series	D1	T1	D3	L1	L2	L3	L4	S1	S2	Weight g/1 piece	Order code*	PN (bar) ¹⁾			
												CF	A3C	71	MS
S ⁴⁾	06	1/8-27 NPT	4	28	21.0	10.0	36	14	17	21	GE06S1/8NPT	630	630	630	
	06	1/4-18 NPT	4	35	28.0	14.5	43	17	17	37	GE06S1/4NPT	630	630	630	400
	06	3/8-18 NPT	4	33	26.0	14.5	41	19	17	40	GE06S3/8NPT	630	630	630	
	06	1/2-14 NPT	4	42	35.0	19.5	50	22	17	71	GE06S1/2NPT	630	630	630	
	08	1/4-18 NPT	5	35	28.0	14.5	43	17	19	38	GE08S1/4NPT	630	630	630	400
	08	3/8-18 NPT	5	35	28.0	14.5	43	19	19	46	GE08S3/8NPT	630	630	630	
	08	1/2-14 NPT	5	42	35.0	19.5	50	22	19	73	GE08S1/2NPT	630	630	630	400
	10	1/4-18 NPT	5	35	27.5	14.5	44	19	22	45	GE10S1/4NPT	630	630	630	
	10	3/8-18 NPT	7	35	27.5	14.5	44	19	22	49	GE10S3/8NPT	630	630	630	400
	10	1/2-14 NPT	7	42	34.5	19.5	51	22	22	73	GE10S1/2NPT	630	630	630	400
	10	3/4-14 NPT	7	44	36.5	19.5	53	30	22	125	GE10S3/4NPT	630	630	630	
	12	1/4-18 NPT	5	37	29.5	14.5	46	22	24	57	GE12S1/4NPT	630	630	630	
	12	3/8-18 NPT	8	37	29.5	14.5	46	22	24	62	GE12S3/8NPT	630	630	630	400
	12	1/2-14 NPT	8	42	34.5	19.5	51	22	24	83	GE12S1/2NPT	630	630	630	400
	12	3/4-14 NPT	8	44	36.5	19.5	53	30	24	126	GE12S3/4NPT	630	630	630	
	14	3/8-18 NPT	8	39	31.0	14.5	49	24	27	77	GE14S3/8NPT	630	630	630	
	14	1/2-14 NPT	10	44	36.0	19.5	54	24	27	89	GE14S1/2NPT	630	630	630	400
	14	3/4-14 NPT	10	46	38.0	19.5	56	30	27	130	GE14S3/4NPT	630	630	630	
	14	1-11 1/2 NPT	10	51	43.0	24.5	61	36	27	180	GE14S1NPT	630	630	630	
	16	3/8-18 NPT	8	39	30.5	14.5	49	27	30	84	GE16S3/8NPT	400	400	400	
16	1/2-14 NPT	12	48	39.5	19.5	58	32	30	97	GE16S1/2NPT	400	400	400	250	
16	3/4-14 NPT	12	46	37.5	19.5	56	30	30	130	GE16S3/4NPT	400	400	400		
16	1-11 1/2 NPT	12	51	42.5	24.5	61	36	30	178	GE16S1NPT	400	400	400		
20	1/2-14 NPT	12	48	37.5	19.5	59	32	36	144	GE20S1/2NPT	400	400	400		
20	3/4-14 NPT	16	48	37.5	19.5	59	32	36	149	GE20S3/4NPT	400	400	400	250	
20	1-11 1/2 NPT	16	55	44.5	24.5	66	36	36	243	GE20S1NPT	400	400	400		
25	3/4-14 NPT	16	52	40.0	19.5	64	41	46	240	GE25S3/4NPT	400	400	400		
25	1-11 1/2 NPT	20	57	45.0	24.5	69	41	46	278	GE25S1NPT	400	400	400		
25	11/4-11 1/2 NPT	20	58	46.0	25.0	70	46	46	396	GE25S11/4NPT	400	400	400		
25	11/2-11 1/2 NPT	20	61	49.0	26.0	73	50	46	469	GE25S11/2NPT	400	400	400		
30	3/4-14 NPT	16	54	40.5	19.5	67	46	50	307	GE30S3/4NPT	400	400	400		
30	1-11 1/2 NPT	20	59	45.5	24.5	72	46	50	343	GE30S1NPT	400	400	400		
30	11/4-11 1/2 NPT	25	60	46.5	25.0	73	46	50	397	GE30S11/4NPT	400	400	400		
30	11/2-11 1/2 NPT	25	60	46.5	26.0	73	50	50	440	GE30S11/2NPT	400	400	400		
38	1-11 1/2 NPT	22	64	48.0	24.5	79	55	60	510	GE38S1NPT	315	315	315		
38	11/4-11 1/2 NPT	25	65	49.0	25.0	80	55	60	535	GE38S11/4NPT	315	315	315		
38	11/2-11 1/2 NPT	32	65	49.0	26.0	80	55	60	571	GE38S11/2NPT	315	315	315		

¹⁾ Pressure shown = item deliverable

⁴⁾ S = heavy series

$$\frac{\text{PN (bar)}}{10} = \text{PN (MPa)}$$

Delivery without nut and ring. Information on ordering complete fittings see page I7.

*Please add the **suffixes** below according to the material/surface required.

Order code suffixes		
Material	Suffix surface and material	Example
Steel, zinc plated, chrome ⁶ -free	CFX	GE16S1/2NPTCFX
Steel, zinc yellow plated	A3CX	GE16S1/2NPTA3CX
Stainless Steel	71X	GE16S1/2NPT71X
Brass	MSX	GE16S1/2NPTMSX

EGEO Swivel connector

Male metric thread – O-ring (ISO 6149) / EO 24° DKO swivel

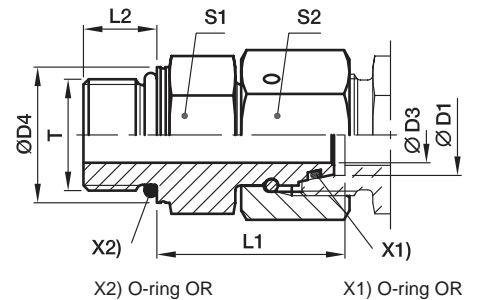

Series	D1 	T	D3	D4	L1	L2	S1	S2	Weight g/1 piece	Order code*	PN (bar) ¹⁾	
											CF	A3C
L ³⁾	06	M 10 1	2.5	13.8	24.5	8.5	14	14	29	EGEO06LM	500	315
	08	M 12 1.5	4.0	16.8	26.5	11.0	17	17	43	EGEO08LM	500	315
	10	M 14 1.5	6.0	18.8	27.5	11.0	19	19	57	EGEO10LM	500	315
	12	M 16 1.5	8.0	21.8	30.5	11.5	22	22	85	EGEO12LM	400	315
	15	M 18 1.5	10.0	23.8	31.5	12.5	24	27	115	EGEO15LM	400	315
	18	M 22 1.5	13.0	26.8	31.5	13.0	27	32	152	EGEO18LM	400	315
	22	M 27 2	17.0	31.8	32.5	16.0	32	36	207	EGEO22LM27X2	250	160
	28	M 33 2	22.0	40.8	35.0	16.0	41	41	294	EGEO28LM	250	160
	35	M 42 2	28.0	49.8	42.5	16.0	50	50	516	EGEO35LM	250	160
	42	M 48 2	34.0	54.8	46.5	17.5	55	60	718	EGEO42LM	250	160
S ⁴⁾	06	M 12 1.5	2.5	16.8	27.0	11.0	17	17	49	EGEO06SM	800	630
	08	M 14 1.5	4.0	18.8	29.5	11.0	19	19	69	EGEO08SM	800	630
	10	M 16 1.5	6.0	21.8	32.0	12.5	22	22	96	EGEO10SM	800	630
	12	M 18 1.5	8.0	23.8	34.0	14.0	24	24	116	EGEO12SM	630	630
	16	M 22 1.5	11.0	26.8	37.0	15.0	27	30	179	EGEO16SM	630	400
	20	M 27 2	14.0	31.8	43.0	18.5	32	36	280	EGEO20SM	420	400
	25	M 33 2	18.0	40.8	48.0	18.5	41	46	502	EGEO25SM	420	400
	30	M 42 2	23.0	49.8	51.0	19.0	50	50	697	EGEO30SM	420	400
	38	M 48 2	30.0	54.8	60.0	21.5	55	60	965	EGEO38SM	420	315

¹⁾ Pressure shown = item deliverable

³⁾ L = light series; ⁴⁾ S = heavy series

$\frac{PN \text{ (bar)}}{10} = PN \text{ (MPa)}$

Information on ordering alternative sealing materials see page 17.

*Please add the **suffixes** below according to the material/surface required.

Order code suffixes			
Material	Suffix surface and material	Example	Standard sealing material (no additional suffix needed)
Steel, zinc plated, chrome ⁶⁾ -free	CF	EGEO16SMCF	NBR
Steel, zinc yellow plated	A3C	EGEO16SMA3C	NBR

EGE-M-ED Swivel connector

Male metric thread – ED-seal (ISO 9974) / EO 24° DKO swivel

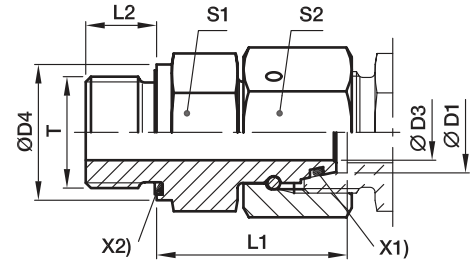

X2) Eolastic-sealing ED X1) O-ring OR

Series	D1	T	D3	D4	L1	L2	S1	S2	Weight g/1 piece	Order code*	PN (bar) ¹⁾		
											CF	A3C	71
L ³⁾	06	M 10 1	2.5	14	24.5	8	14	14	27	EGE06LMED	500	315	315
	08	M 12 1.5	4.0	17	26.5	12	17	17	45	EGE08LMED	500	315	315
	10	M 14 1.5	6.0	19	27.5	12	19	19	57	EGE10LMED	500	315	315
	12	M 16 1.5	8.0	22	30.5	12	22	22	82	EGE12LMED	400	315	315
	12	M 22 1.5	8.0	27	27.0	14	27	22	92	EGE12LM22X1.5ED	400	315	315
	15	M 18 1.5	10.0	24	31.5	12	24	27	113	EGE15LMED	400	315	315
	15	M 22 1.5	10.0	27	32.0	14	27	27	142	EGE15LM22X1.5ED	400	315	315
	18	M 22 1.5	13.0	27	31.5	14	27	32	148	EGE18LMED	400	315	315
	22	M 26 1.5	17.0	32	32.5	16	32	36	203	EGE22LMED	250	160	160
	28	M 33 2	22.0	40	35.0	18	41	41	289	EGE28LMED	250	160	160
	35	M 42 2	28.0	50	42.5	20	50	50	511	EGE35LMED	250	160	160
	42	M 48 2	34.0	55	46.5	22	55	60	711	EGE42LMED	250	160	160
S ⁴⁾	06	M 12 1.5	2.5	17	27.0	12	17	17	47	EGE06SMED	800	630	630
	08	M 14 1.5	4.0	19	29.5	12	19	19	65	EGE08SMED	800	630	630
	10	M 16 1.5	6.0	22	32.0	12	22	22	91	EGE10SMED	800	630	630
	12	M 18 1.5	8.0	24	34.0	12	24	24	112	EGE12SMED	630	630	630
	14	M 20 1.5	9.0	26	36.5	14	27	27	153	EGE14SMED	630	630	630
	16	M 22 1.5	11.0	27	37.0	14	27	30	174	EGE16SMED	630	400	400
	20	M 27 2	14.0	32	43.0	16	32	36	274	EGE20SMED	420	400	400
	25	M 33 2	18.0	40	48.0	18	41	46	497	EGE25SMED	420	400	400
	30	M 42 2	23.0	50	51.0	20	50	50	691	EGE30SMED	420	400	400
	38	M 48 2	30.0	55	60.0	22	55	60	957	EGE38SMED	420	315	315

¹⁾ Pressure shown = item deliverable

³⁾ L = light series; ⁴⁾ S = heavy series

$$\frac{\text{PN (bar)}}{10} = \text{PN (MPa)}$$

Information on ordering alternative sealing materials see page 17.

*Please add the **suffixes** below according to the material/surface required.

Order code suffixes			
Material	Suffix surface and material	Example	Standard sealing material (no additional suffix needed)
Steel, zinc plated, chrome ⁶⁾ -free	CF	EGE16SMEDCF	NBR
Steel, zinc yellow plated	A3C	EGE16SMEDA3C	NBR
Stainless Steel	71	EGE16SMED71	VIT

EGE-R-ED Swivel connector

Male BSPP thread – ED-seal (ISO 1179) / EO 24° DKO swivel

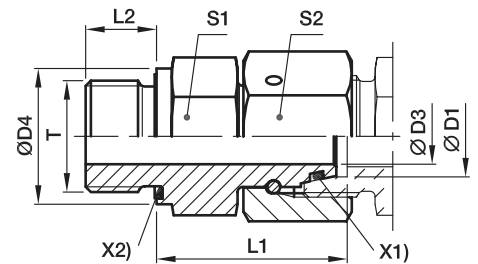

X2) Elastic-sealing ED X1) O-ring OR

Series	D1	T	D3	D4	L1	L2	S1	S2	Weight g/1 piece	Order code*	PN (bar) ¹⁾		
											CF	A3C	71
L ³⁾	06	G 1/8 A	2.5	14	24.5	8	14	14	27	EGE06LRED	500	315	315
	08	G 1/4 A	4.0	19	29.5	12	19	17	28	EGE08LRED	500	315	315
	10	G 1/4 A	6.0	19	27.5	12	19	19	54	EGE10LRED	500	315	315
	10	G 3/8 A	6.0	22	29.0	12	22	19	70	EGE10LR3/8ED	400	315	
	12	G 3/8 A	8.0	22	34.0	12	22	22	95	EGE12LRED	400	315	315
	12	G 1/4 A	6.0	19	27.5	12	19	22	65	EGE12LR1/4ED	400	315	
	12	G 1/2 A	8.0	27	29.5	14	27	22	114	EGE12LR1/2ED	400	315	
	15	G 1/2 A	10.0	27	32.0	14	27	27	137	EGE15LRED	400	315	315
	18	G 1/2 A	13.0	27	31.5	14	27	32	143	EGE18LRED	400	315	315
	18	G 3/4 A	13.0	32	29.5	16	32	32	182	EGE18LR3/4ED	250	160	
	22	G 3/4 A	17.0	32	32.5	16	32	36	200	EGE22LRED	250	160	160
	28	G 1 A	22.0	40	35.0	18	41	41	289	EGE28LRED	250	160	160
	35	G 1 1/4 A	28.0	50	42.5	20	50	50	500	EGE35LRED	250	160	160
	42	G 1 1/2 A	34.0	55	46.5	22	55	60	718	EGE42LRED	250	160	160
S ⁴⁾	06	G 1/4 A	2.5	19	27.0	12	19	17	53	EGE06SRED	800	630	630
	08	G 1/4 A	4.0	19	29.5	12	19	19	64	EGE08SRED	800	630	630
	10	G 3/8 A	6.0	22	32.0	12	22	22	93	EGE10SRED	800	630	630
	12	G 3/8 A	8.0	22	34.0	12	22	24	100	EGE12SRED	630	630	630
	12	G 1/4 A	5.0	19	31.5	12	19	24	140	EGE12SR1/4ED	630	630	
	12	G 1/2 A	8.0	27	35.0	14	27	24	140	EGE12SR1/2ED	630	630	630
	14	G 1/2 A	9.0	27	36.5	14	27	27	157	EGE14SRED	630	630	630
	16	G 1/2 A	11.0	27	37.0	14	27	30	170	EGE16SRED	630	400	400
	20	G 3/4 A	14.0	32	43.0	16	32	36	273	EGE20SRED	420	400	400
	25	G 1 A	18.0	40	48.0	18	41	46	493	EGE25SRED	420	400	400
	30	G 1 1/4 A	23.0	50	51.0	20	50	50	691	EGE30SRED	420	400	
	38	G 1 1/2 A	30.0	55	60.0	22	55	60	934	EGE38SRED	420	315	315

¹⁾ Pressure shown = item deliverable

³⁾ L = light series; ⁴⁾ S = heavy series

$$\frac{\text{PN (bar)}}{10} = \text{PN (MPa)}$$

Information on ordering alternative sealing materials see page 17.

Order code suffixes			
Material	Suffix surface and material	Example	Standard sealing material (no additional suffix needed)
Steel, zinc plated, chrome ⁶⁾ -free	CF	EGE16SREDCF	NBR
Steel, zinc yellow plated	A3C	EGE16SREDA3C	NBR
Stainless Steel	71	EGE16SRED71	VIT

*Please add the **suffixes** below according to the material/surface required.

EVGE-M-ED Standpipe connector

Male metric thread – ED (ISO 9974) / EO standpipe adjustable

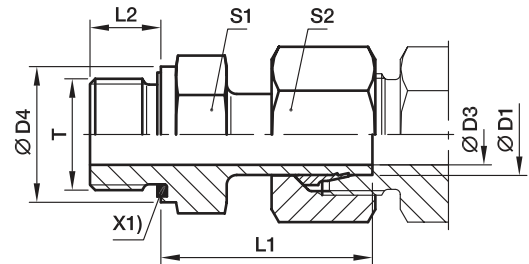

Pre-assembled nut and ring.
Final assembly (in appropriate body) at least 1/4 turn beyond the point of clearly perceptible resistance.

X1) Eolastic-sealing ED

Series	D1	T	D3	D4	L1	L2	S1	S2	Weight g/1 piece	Order code*	PN (bar) ¹⁾		
											CF	A3C	71
L ³⁾	06	M 10 1	3.5	14	24.5	8	14	14	24	EVGE06LMED	315	315	315
	08	M 12 1.5	5.5	17	26.5	12	17	17	38	EVGE08LMED	315	315	315
	10	M 14 1.5	7.0	19	27.5	12	19	19	49	EVGE10LMED	315	315	315
	12	M 16 1.5	9.0	22	30.0	12	22	22	67	EVGE12LMED	315	315	315
	15	M 18 1.5	11.0	24	30.5	12	24	27	95	EVGE15LMED	315	315	315
	18	M 22 1.5	14.0	27	31.5	14	27	32	137	EVGE18LMED	315	315	315
	22	M 26 1.5	18.0	32	32.5	16	32	36	183	EVGE22LMED	160	160	160
	28	M 33 2	23.0	40	35.0	18	41	41	264	EVGE28LMED	160	160	160
	35	M 42x2	29.5	50	42.5	20	50	50	444	EVGE35LMED	160	160	160
	42	M 48 2	35.5	55	46.5	22	55	60	614	EVGE42LMED	160	160	160
S ⁴⁾	06	M 12 1.5	3.5	17	27.0	12	17	17	43	EVGE06SMED	630	630	630
	08	M 14x1.5	4.5	19	29.5	12	19	19	59	EVGE08SMED	630	630	630
	10	M 16 1.5	6.5	22	32.0	12	22	22	82	EVGE10SMED	630	630	630
	12	M 18 1.5	7.5	24	34.0	12	24	24	104	EVGE12SMED	630	630	630
	14	M 20 1.5	9.5	26	36.5	14	27	27	144	EVGE14SMED	630	630	630
	16	M 22 1.5	11.5	27	37.0	14	27	30	162	EVGE16SMED	400	400	400
	20	M 27 2	15.5	32	43.0	16	32	36	254	EVGE20SMED	400	400	400
	25	M 33 2	18.0	40	48.0	18	41	46	493	EVGE25SMED	400	400	400
	30	M 42 2	23.5	50	51.0	20	50	50	654	EVGE30SMED	400	400	400
	38	M 48 2	29.0	55	60.0	22	55	60	962	EVGE38SMED	315	315	315

¹⁾ Pressure shown = item deliverable

³⁾ L = light series; ⁴⁾ S = heavy series

$$\frac{\text{PN (bar)}}{10} = \text{PN (MPa)}$$

Information on ordering alternative sealing materials see page 17.

*Please add the **suffixes** below according to the material/surface required.

Order code suffixes			
Material	Suffix surface and material	Example	Standard sealing material (no additional suffix needed)
Steel, zinc plated, chrome ⁶⁾ -free	CF	EGE16SMEDCF	NBR
Steel, zinc yellow plated	A3C	EGE16SMEDA3C	NBR
Stainless Steel	71	EGE16SMED71	VIT

EVGE-R-ED Standpipe connector

Male BSPP thread – ED-seal (ISO 1179) / EO standpipe adjustable

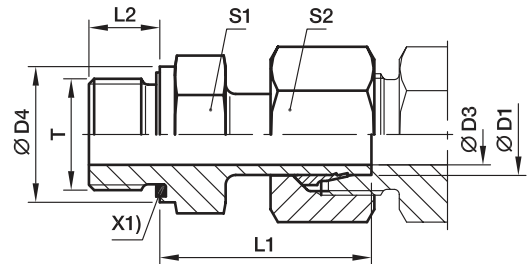

Pre-assembled nut and ring.
Final assembly (in appropriate body) at least 1/4 turn beyond the point of clearly perceptible resistance.

X1) Eolastic-sealing ED

Series	D1	T	D3	D4	L1	L2	S1	S2	Weight g/1 piece	Order code*	PN (bar) ¹⁾			
											CF	A3C	71	MS
L ³⁾	06	G 1/8 A	3.5	14	24.5	8	14	14	24	EVGE06LRED	315	315	315	200
	08	G 1/4 A	4.5	19	29.5	12	19	17	52	EVGE08LRED	315	315	315	200
	10	G 1/4 A	7.0	19	27.5	12	19	19	47	EVGE10LRED	315	315	315	200
	12	G 3/8 A	7.5	22	34.0	12	22	22	87	EVGE12LRED	315	315	315	200
	12	G 1/4 A	7.0	19	28.5	12	19	22	61	EVGE12LR1/4ED	315	315		
	12	G 1/2 A	7.5	27	34.5	14	27	22	121	EVGE12LR1/2ED	315	315	315	
	15	G 1/2 A	11.0	27	31.0	14	27	27	114	EVGE15LRED	315	315	315	200
	18	G 1/2 A	14.0	27	31.5	14	27	32	132	EVGE18LRED	315	315	315	200
	22	G 3/4 A	18.0	32	32.5	16	32	36	183	EVGE22LRED	160	160	160	100
	28	G 1 A	23.0	40	35.0	18	41	41	262	EVGE28LRED	160	160	160	
	35	G 1 1/4 A	29.5	50	42.5	20	50	50	436	EVGE35LRED	160	160	160	
	42	G 1 1/2 A	35.5	55	46.5	22	55	60	615	EVGE42LRED	160	160	160	
S ⁴⁾	06	G 1/4 A	3.5	19	27.0	12	19	17	48	EVGE06SRED	630	630	630	
	08	G 1/4 A	4.5	19	29.5	12	19	19	57	EVGE08SRED	630	630	630	
	10	G 3/8 A	6.5	22	32.0	12	22	22	84	EVGE10SRED	630	630	630	
	12	G 3/8 A	7.5	22	34.0	12	22	24	95	EVGE12SRED	630	630	630	
	12	G 1/2 A	7.5	27	34.5	14	27	24	130	EVGE12SR1/2ED	630	630	630	
	14	G 1/2 A	9.5	27	36.5	14	27	27	149	EVGE14SRED	630	630	630	
	16	G 1/2 A	11.5	27	37.0	14	27	30	158	EVGE16SRED	400	400	400	
	16	G 3/4 A	11.5	32	39.0	16	32	30	222	EVGE16SR3/4ED	400	400		
	20	G 3/4 A	15.5	32	43.0	16	32	36	254	EVGE20SRED	400	400	400	
	25	G 1 A	18.0	40	48.0	18	41	46	485	EVGE25SRED	400	400	400	
	30	G 1 1/4 A	23.5	50	51.0	20	50	50	661	EVGE30SRED	400	400	400	
	38	G 1 1/2 A	29.0	55	60.0	22	55	60	962	EVGE38SRED	315	315	315	

¹⁾ Pressure shown = item deliverable

³⁾ L = light series; ⁴⁾ S = heavy series

$$\frac{\text{PN (bar)}}{10} = \text{PN (MPa)}$$

Information on ordering alternative sealing materials see page 17.

*Please add the **suffixes** below according to the material/surface required.

Order code suffixes			
Material	Suffix surface and material	Example	Standard sealing material (no additional suffix needed)
Steel, zinc plated, chrome ⁶⁾ -free	CF	EVGE16SREDCF	NBR
Steel, zinc yellow plated	A3C	EVGE16SREDA3C	NBR
Stainless Steel	71	EVGE16SRED71	VIT
Brass	MS	EVGE16SREDMS	NBR

EGE-NPT Swivel connector

Male NPT thread (SAE J476) / EO 24° DKO swivel

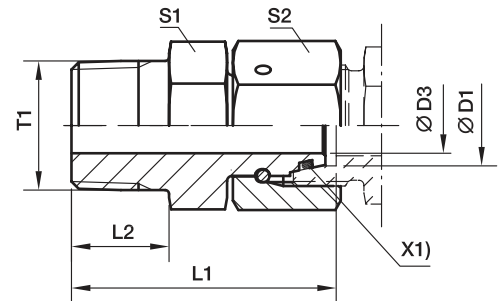

X1) O-ring OR

Series	D1	T1	D3	L1	L2	S1	S2	Weight g/1 piece	Order code*	PN (bar) ¹⁾	
										CF	A3C
L ³⁾	06	1/8-27NPT	2.5	31.5	10.0	11	14	23	EGE06L1/8NPT	315	315
	08	1/4-18NPT	4.0	37.5	14.5	14	17	41	EGE08L1/4NPT	315	315
	10	1/4-18NPT	6.0	38.0	14.5	14	19	44	EGE10L1/4NPT	315	315
	12	3/8-18NPT	8.0	40.0	14.5	19	22	69	EGE12L3/8NPT	315	315
	15	1/2-14NPT	10.0	49.5	19.5	22	27	127	EGE15L1/2NPT	315	315
	18	1/2-14NPT	12.0	49.0	19.5	24	32	142	EGE18L1/2NPT	315	315
	22	3/4-14NPT	16.0	52.0	19.5	27	36	200	EGE22L3/4NPT	160	160
	28	1-11 1/2NPT	22.0	61.0	24.5	36	41	306	EGE28L1NPT	160	160
	35	1 1/4-11 1/2NPT	28.0	65.5	25.0	46	50	486	EGE35L11/4NPT	160	160
	42	1 1/2-11 1/2NPT	34.0	68.5	26.0	50	60	662	EGE42L11/2NPT	160	160
S ⁴⁾	06	1/4-18NPT	2.5	37.5	14.5	14	17	42	EGE06S1/4NPT	630	630
	08	1/4-18NPT	4.0	38.0	14.5	14	19	47	EGE08S1/4NPT	630	630
	10	3/8-18NPT	6.0	40.5	14.5	19	22	75	EGE10S3/8NPT	630	630
	12	3/8-18NPT	8.0	42.0	14.5	19	24	81	EGE12S3/8NPT	630	630
	14	1/2-14NPT	9.0	50.5	19.5	22	27	131	EGE14S1/2NPT	630	630
	16	1/2-14NPT	11.0	51.0	19.5	22	30	145	EGE16S1/2NPT	400	400
	20	3/4-14NPT	14.0	54.0	19.5	27	36	221	EGE20S3/4NPT	400	400
	25	1-11 1/2NPT	18.0	63.5	24.5	36	46	422	EGE25S1NPT	400	400
	30	1 1/4-11 1/2NPT	23.0	70.5	25.0	46	50	628	EGE30S11/4NPT	400	400
	38	1 1/2-11 1/2NPT	30.0	73.5	26.0	50	60	770	EGE38S11/2NPT	315	315

¹⁾ Pressure shown = item deliverable

³⁾ L = light series; ⁴⁾ S = heavy series

$$\frac{\text{PN (bar)}}{10} = \text{PN (MPa)}$$

Information on ordering alternative sealing materials see page 17.

*Please add the **suffixes** below according to the material/surface required.

Order code suffixes			
Material	Suffix surface and material	Example	Standard sealing material (no additional suffix needed)
Steel, zinc plated, chrome ⁶ -free	CF	EGE16S1/2NPTCF	NBR
Steel, zinc yellow plated	A3C	EGE16S1/2NPTA3C	NBR

EW-M-ED Assembled adjustable swivel elbow

EO 24° cone end / Male metric thread – ED-seal (ISO 9974)

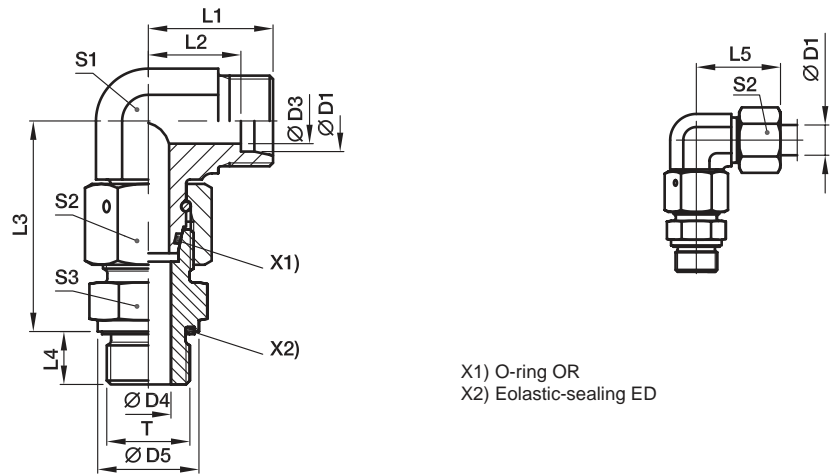

X1) O-ring OR
X2) Eolastic-sealing ED

Series	D1	T	D3	D4	D5	L1	L2	L3	L4	L5	S1	S2	S3	Weight g/1 piece	Order code*	PN (bar) ¹⁾		
																CF	A3C	71
L ³⁾	06	M 10 1	4	4	14	19	12.0	34.5	8	27	12	14	14	47	EW06LMEDOMD	500	315	315
	08	M 12 1.5	6	6	17	21	14.0	37.5	12	29	12	17	17	69	EW08LMEDOMD	500	315	315
	10	M 14 1.5	8	7	19	22	15.0	40.0	12	30	14	19	19	87	EW10LMEDOMD	500	315	315
	12	M 16 1.5	10	9	22	24	17.0	42.0	12	32	17	22	22	111	EW12LMEDOMD	400	315	315
	15	M 18 1.5	12	11	24	28	21.0	46.0	12	36	19	27	24	179	EW15LMEDOMD	400	315	315
	18	M 22 1.5	15	14	27	31	23.5	50.0	14	40	24	32	27	272	EW18LMEDOMD	400	315	315
	22	M 26 1.5	19	18	32	35	27.5	55.0	16	44	27	36	32	360	EW22LMEDOMD	250	160	160
	28	M 33 2	24	23	40	38	30.5	59.0	18	47	36	41	41	538	EW28LMEDOMD	250	160	160
	35	M 42 2	30	30	50	45	34.5	68.5	20	56	41	50	50	843	EW35LMEDOMD	250	160	160
	42	M 48 2	36	36	55	51	40.0	75.0	22	63	50	60	55	1353	EW42LMEDOMD	250	160	160
S ⁴⁾	06	M 12 1.5	4	4	17	23	16.0	40.0	12	31	12	17	17	77	EW06SMEDOMD	800	630	630
	08	M 14 1.5	5	5	19	24	17.0	42.5	12	32	14	19	19	107	EW08SMEDOMD	800	630	630
	10	M 16 1.5	6	7	22	25	17.5	45.0	12	34	17	22	22	146	EW10SMEDOMD	800	630	630
	12	M 18 1.5	8	8	24	29	21.5	48.0	12	38	17	24	24	178	EW12SMEDOMD	630	630	630
	14	M 20 1.5	9	10	26	30	22.0	54.0	14	40	19	27	27	203	EW14SMEDOMD	630	630	630
	16	M 22 1.5	12	12	27	33	24.5	55.0	14	43	24	30	27	307	EW16SMEDOMD	630	400	400
	20	M 27 2	16	16	32	37	26.5	65.0	16	48	27	36	32	459	EW20SMEDOMD	420	400	400
	25	M 33 2	20	20	40	42	30.0	73.0	18	54	36	46	41	812	EW25SMEDOMD	420	400	400
	30	M 42 2	25	25	50	49	35.5	78.5	20	62	41	50	50	1167	EW30SMEDOMD	420	400	400
	38	M 48 2	32	32	55	57	41.0	89.0	22	72	50	60	55	1790	EW38SMEDOMD	420	315	315

¹⁾ Pressure shown = item deliverable

³⁾ L = light series; ⁴⁾ S = heavy series

$\frac{PN(\text{bar})}{10} = PN(\text{MPa})$

Delivery without nut and ring. Information on ordering complete fittings or alternative sealing materials see page 17.

Order code suffixes			
Material	Suffix surface and material	Example	Standard sealing material (no additional suffix needed)
Steel, zinc plated, chrome ⁶⁾ -free	CF	EW16SMEDOMDCF	NBR
Steel, zinc yellow plated	A3C	EW16SMEDOMDA3C	NBR
Stainless Steel	71	EW16SMEDOMD71	VIT

*Please add the **suffixes** below according to the material/surface required.

EW-R-ED Assembled adjustable swivel elbow

EO 24° cone end / Male BSPP thread – ED-seal (ISO 1179)

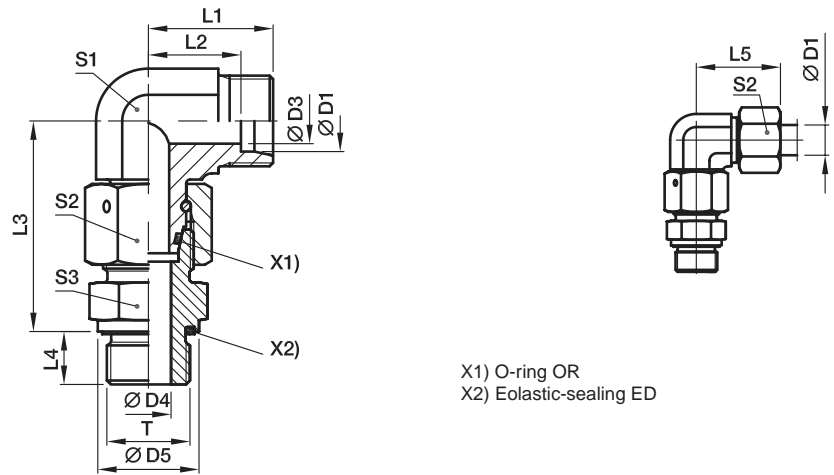

X1) O-ring OR
X2) Eolastic-sealing ED

Series	D1	T	D3	D4	D5	L1	L2	L3	L4	L5	S1	S2	S3	Weight g/1 piece	Order code*	PN (bar) ¹⁾		
																CF	A3C	71
L ³⁾	06	G 1/8 A	4	4	14	19	12.0	34.5	8	27	12	14	14	47	EW06LREDOMD	500	315	315
	08	G 1/4 A	6	6	19	21	14.0	37.5	12	29	12	17	19	69	EW08LREDOMD	500	315	315
	10	G 1/4 A	8	6	19	22	15.0	40.0	12	30	14	19	19	87	EW10LREDOMD	500	315	315
	12	G 3/8 A	10	9	22	24	17.0	42.0	12	32	17	22	22	122	EW12LREDOMD	400	315	315
	15	G 1/2 A	12	11	27	28	21.0	46.5	14	36	19	27	27	199	EW15LREDOMD	400	315	315
	18	G 1/2 A	15	14	27	31	23.5	50.0	14	40	24	32	27	268	EW18LREDOMD	400	315	315
	22	G 3/4 A	19	18	32	35	27.5	55.0	16	44	27	36	32	360	EW22LREDOMD	250	160	160
	28	G 1 A	24	23	40	38	30.5	59.0	18	47	36	41	41	539	EW28LREDOMD	250	160	160
	35	G 1 1/4 A	30	30	50	45	34.5	68.5	20	56	41	50	50	834	EW35LREDOMD	250	160	160
	42	G 1 1/2 A	36	36	55	51	40.0	75.0	22	63	50	60	55	1341	EW42LREDOMD	250	160	160
S ⁴⁾	06	G 1/4 A	4	4	19	23	16.0	40.0	12	31	12	17	19	83	EW06SREDOMD	800	630	630
	08	G 1/4 A	5	5	19	24	17.0	42.5	12	32	14	19	19	106	EW08SREDOMD	800	630	630
	10	G 3/8 A	6	7	22	25	17.5	45.0	12	34	17	22	22	148	EW10SREDOMD	800	630	630
	12	G 3/8 A	8	8	22	29	21.5	48.0	12	38	17	24	22	170	EW12SREDOMD	630	630	630
	14	G 1/2 A	9	10	27	30	22.0	54.0	14	40	19	27	27	242	EW14SREDOMD	630	630	630
	16	G 1/2 A	12	12	27	33	24.5	55.0	14	43	24	30	27	303	EW16SREDOMD	630	400	400
	20	G 3/4 A	16	16	32	37	26.5	65.0	16	48	27	36	32	458	EW20SREDOMD	420	400	400
	25	G 1 A	20	20	40	42	30.0	73.0	18	54	36	46	41	813	EW25SREDOMD	420	400	400
	30	G 1 1/4 A	25	25	50	49	35.5	78.5	20	62	41	50	50	1163	EW30SREDOMD	420	400	400
	38	G 1 1/2 A	32	32	55	57	41.0	89.0	22	72	50	60	55	1784	EW38SREDOMD	420	315	315

¹⁾ Pressure shown = item deliverable

³⁾ L = light series; ⁴⁾ S = heavy series

$\frac{PN(\text{bar})}{10} = PN(\text{MPa})$

Delivery without nut and ring. Information on ordering complete fittings or alternative sealing materials see page 17.

Order code suffixes			
Material	Suffix surface and material	Example	Standard sealing material (no additional suffix needed)
Steel, zinc plated, chrome ⁶⁾ -free	CF	EW16SREDOMDCF	NBR
Steel, zinc yellow plated	A3C	EW16SREDOMDA3C	NBR
Stainless Steel	71	EW16SREDOMD71	VIT

*Please add the **suffixes** below according to the material/surface required.

EV-M-ED Assembled adjustable swivel 45° elbow

EO 24° cone end / Male metric thread – ED-seal (ISO 9974)

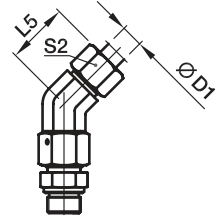
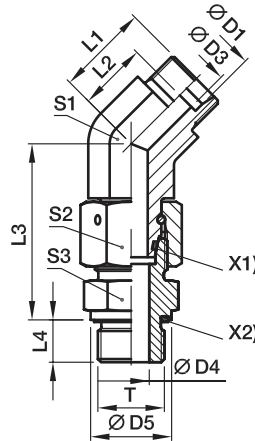

X1) O-ring OR
X2) Elastic-sealing ED

Series	D1	T	D3	D4	D5	L1	L2	L3	L4	L5	S1	S2	S3	Weight g/1 piece	Order code*	PN (bar) ¹⁾		
																CF	A3C	71
L ³⁾	06	M 10 1.0	4	4	14	16.0	9.0	34.5	8	24	14	14	14	44	EV06LMEDOMD	315	315	315
	08	M 12 1.5	6	6	17	19.0	12.0	37.5	12	27	14	17	17	62	EV08LMEDOMD	315	315	315
	10	M 14 1.5	8	7	19	19.0	12.0	40.0	12	27	19	19	19	80	EV10LMEDOMD	315	315	315
	12	M 16 1.5	10	9	22	21.0	14.0	42.0	12	29	19	22	22	110	EV12LMEDOMD	315	315	315
	15	M 18 1.5	12	11	24	24.0	17.0	46.0	12	32	22	27	24	171	EV15LMEDOMD	315	315	315
	18	M 22 1.5	15	14	27	24.0	16.5	50.0	14	33	27	32	27	245	EV18LMEDOMD	315	315	315
	22	M 26 1.5	19	18	32	26.0	18.5	55.0	16	35	30	36	32	339	EV22LMEDOMD	160	160	160
	28	M 33 2.0	24	23	40	30.5	23.0	59.0	18	40	36	41	41	517	EV28LMEDOMD	160	160	160
	35	M 42 2.0	30	30	50	37.0	26.5	68.5	20	48	50	50	50	810	EV35LMEDOMD	160	160	160
	42	M 48 2.0	36	36	55	37.0	26.0	75.0	22	49	50	60	55	1193	EV42LMEDOMD	160	160	160
S ⁴⁾	06	M 12 1.5	4	4	17	16.0	9.0	40.0	12	24	14	17	17	72	EV06SMEDOMD	630	630	630
	08	M 14 1.5	5	5	19	19.0	12.0	42.5	12	27	19	19	19	102	EV08SMEDOMD	630	630	630
	10	M 16 1.5	7	7	22	21.0	13.5	45.0	12	30	19	22	22	132	EV10SMEDOMD	630	630	630
	12	M 18 1.5	8	8	24	24.0	16.5	48.0	12	33	19	24	24	173	EV12SMEDOMD	630	630	630
	16	M 22 1.5	12	12	27	24.0	15.5	55.0	14	34	19	30	27	284	EV16SMEDOMD	400	400	400
	20	M 27 2.0	16	16	32	26.5	16.0	65.0	16	38	27	36	32	435	EV20SMEDOMD	400	400	400
	25	M 33 2.0	20	20	40	30.5	18.5	73.0	18	43	36	46	41	790	EV25SMEDOMD	400	400	400
	30	M 42 2.0	25	25	50	37.0	23.5	78.5	20	50	50	50	50	1132	EV30SMEDOMD	400	400	400
	38	M 48 2.0	32	32	55	37.0	21.0	89.0	22	52	50	60	55	1631	EV38SMEDOMD	315	315	315

¹⁾ Pressure shown = item deliverable

³⁾ L = light series; ⁴⁾ S = heavy series

$$\frac{\text{PN (bar)}}{10} = \text{PN (MPa)}$$

Delivery without nut and ring. Information on ordering complete fittings or alternative sealing materials see page I7.

*Please add the **suffixes** below according to the material/surface required.

Order code suffixes			
Material	Suffix surface and material	Example	Standard sealing material (no additional suffix needed)
Steel, zinc plated, chrome ⁶⁾ -free	CF	EV16SMEDOMDCF	NBR
Steel, zinc yellow plated	A3C	EV16SMEDOMDA3C	NBR
Stainless Steel	71	EV16SMEDOMD71	VIT

EV-R-ED Assembled adjustable swivel 45° elbow

EO 24° cone end / Male BSPP thread – ED-seal (ISO 1179)

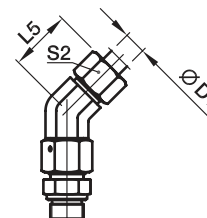
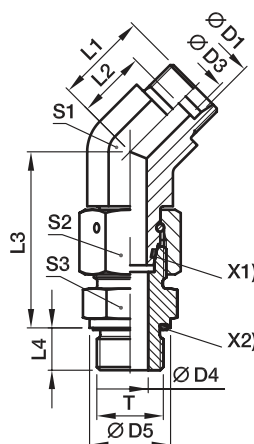

X1) O-ring OR
X2) Eolastic-sealing ED

Series	D1	T	D3	D4	D5	L1	L2	L3	L4	L5	S1	S2	S3	Weight g/1 piece	Order code*	PN (bar) ¹⁾		
																CF	A3C	71
L ³⁾	06	G 1/8 A	4	4	14	16.0	9.0	34.5	8	24	14	14	14	44	EV06LREDOMD	315	315	315
	08	G 1/4 A	6	6	19	19.0	12.0	37.5	12	27	14	17	19	67	EV08LREDOMD	315	315	315
	10	G 1/4 A	8	6	19	19.0	12.0	40.0	12	27	19	19	19	78	EV10LREDOMD	315	315	315
	12	G 3/8 A	10	9	22	21.0	14.0	42.0	12	29	19	22	22	112	EV12LREDOMD	315	315	315
	15	G 1/2 A	12	11	27	24.0	17.0	46.5	14	32	22	27	27	192	EV15LREDOMD	315	315	315
	18	G 1/2 A	15	14	27	24.0	16.5	50.0	14	33	27	32	27	242	EV18LREDOMD	315	315	315
	22	G 3/4 A	19	18	32	26.0	18.5	55.0	16	35	30	36	32	338	EV22LREDOMD	160	160	160
	28	G 1 A	24	23	40	30.5	23.0	59.0	18	40	36	41	41	518	EV28LREDOMD	160	160	160
	35	G 1 1/4 A	30	30	50	37.0	26.5	68.5	20	48	50	50	50	801	EV35LREDOMD	160	160	160
	42	G 1 1/2 A	36	36	55	37.0	26.0	75.0	22	49	50	60	55	1181	EV42LREDOMD	160	160	160
S ⁴⁾	06	G 1/4 A	4	4	19	16.0	9.0	40.0	12	24	14	17	19	78	EV06SREDOMD	630	630	630
	08	G 1/4 A	5	5	19	19.0	12.0	42.5	12	27	19	19	19	101	EV08SREDOMD	630	630	630
	10	G 3/8 A	7	7	22	21.0	13.5	45.0	12	30	19	22	22	134	EV10SREDOMD	630	630	630
	12	G 3/8 A	8	8	22	24.0	16.5	48.0	12	33	19	24	22	165	EV12SREDOMD	630	630	630
	16	G 1/2 A	12	12	27	24.0	15.5	55.0	14	34	19	30	27	280	EV16SREDOMD	400	400	400
	20	G 3/4 A	16	16	32	26.5	16.0	65.0	16	38	27	36	32	434	EV20SREDOMD	400	400	400
	25	G 1 A	20	20	40	30.5	18.5	73.0	18	43	36	46	41	792	EV25SREDOMD	400	400	400
	30	G 1 1/4 A	25	25	50	37.0	23.5	78.5	20	50	50	50	50	1128	EV30SREDOMD	400	400	400
	38	G 1 1/2 A	32	32	55	37.0	21.0	89.0	22	52	50	60	55	1625	EV38SREDOMD	315	315	315

¹⁾ Pressure shown = item deliverable

³⁾ L = light series; ⁴⁾ S = heavy series

$$\frac{\text{PN (bar)}}{10} = \text{PN (MPa)}$$

Delivery without nut and ring. Information on ordering complete fittings or alternative sealing materials see page I7.

*Please add the **suffixes** below according to the material/surface required.

Order code suffixes			
Material	Suffix surface and material	Example	Standard sealing material (no additional suffix needed)
Steel, zinc plated, chrome ⁶⁾ -free	CF	EV16SREDOMDCF	NBR
Steel, zinc yellow plated	A3C	EV16SREDOMDA3C	NBR
Stainless Steel	71	EV16SREDOMD71	VIT

ET-M-ED Assembled adjustable swivel branch tee

EO 24° cone end / Male metric thread – ED-seal (ISO 9974)

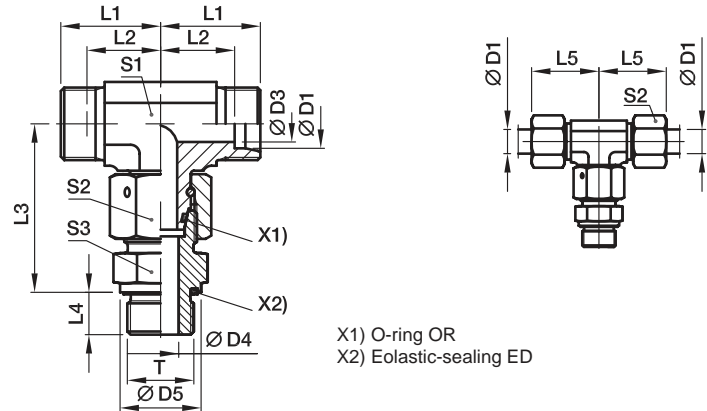

Series	D1	T	D3	D4	D5	L1	L2	L3	L4	L5	S1	S2	S3	Weight g/1 piece	Order code*	PN (bar) ¹⁾		
																CF	A3C	71
L ³⁾	06	M 10 1	4	4	14	19	12.0	34.5	8	27	12	14	14	55	ET06LMEDOMD	500	315	315
	08	M 12 1.5	6	6	17	21	14.0	37.5	12	29	12	17	17	75	ET08LMEDOMD	500	315	315
	10	M 14 1.5	8	7	19	22	15.0	40.0	12	30	14	19	19	98	ET10LMEDOMD	500	315	315
	12	M 16 1.5	10	9	22	24	17.0	42.0	12	32	17	22	22	135	ET12LMEDOMD	400	315	315
	15	M 18 1.5	12	11	24	28	21.0	46.0	12	36	19	27	24	203	ET15LMEDOMD	400	315	315
	18	M 22 1.5	15	14	27	31	23.5	50.0	14	40	24	32	27	310	ET18LMEDOMD	400	315	315
	22	M 26 1.5	19	18	32	35	27.5	55.0	16	44	27	36	32	377	ET22LMEDOMD	250	160	160
	28	M 33 2	24	23	40	38	30.5	59.0	18	47	36	41	41	607	ET28LMEDOMD	250	160	160
	35	M 42 2	30	30	50	45	34.5	68.5	20	56	41	50	50	929	ET35LMEDOMD	250	160	160
	42	M 48 2	36	36	55	51	40.0	75.0	22	63	50	60	55	1478	ET42LMEDOMD	250	160	160
S ⁴⁾	06	M 12 1.5	4	4	17	23	16.0	40.0	12	31	12	17	17	92	ET06SMEDOMD	800	630	630
	08	M 14 1.5	5	5	19	24	17.0	42.5	12	32	14	19	19	126	ET08SMEDOMD	800	630	630
	10	M 16 1.5	6	7	22	25	17.5	45.0	12	34	17	22	22	167	ET10SMEDOMD	800	630	630
	12	M 18 1.5	8	8	24	29	21.5	48.0	12	38	17	24	24	207	ET12SMEDOMD	630	630	630
	14	M 20 1.5	9	10	26	30	22.0	54.0	14	40	19	27	27	287	ET14SMEDOMD	630	630	630
	16	M 22 1.5	12	12	27	33	24.5	55.0	14	43	24	30	27	352	ET16SMEDOMD	630	400	400
	20	M 27 2	16	16	32	37	26.5	65.0	16	48	27	36	32	498	ET20SMEDOMD	420	400	400
	25	M 33 2	20	20	40	42	30.0	73.0	18	54	36	46	41	916	ET25SMEDOMD	420	400	400
	30	M 42 2	25	25	50	49	35.5	78.5	20	62	41	50	50	1328	ET30SMEDOMD	420	400	400
	38	M 48 2	32	32	55	57	41.0	89.0	22	72	50	60	55	2031	ET38SMEDOMD	420	315	315

¹⁾ Pressure shown = item deliverable

³⁾ L = light series; ⁴⁾ S = heavy series

$\frac{PN(\text{bar})}{10} = PN(\text{MPa})$

Delivery without nut and ring. Information on ordering complete fittings or alternative sealing materials see page 17.

Order code suffixes			
Material	Suffix surface and material	Example	Standard sealing material (no additional suffix needed)
Steel, zinc plated, chrome ⁶⁾ -free	CF	ET16SMEDOMDCF	NBR
Steel, zinc yellow plated	A3C	ET16SMEDOMDA3C	NBR
Stainless Steel	71	ET16SMEDOMD71	VIT

*Please add the **suffixes** below according to the material/surface required.

ET-R-ED Assembled adjustable swivel branch tee

EO 24° cone end / Male BSPP thread – ED-seal (ISO 1179)

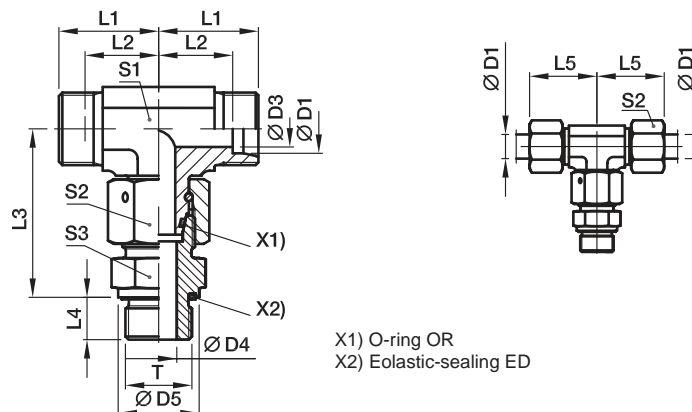

Series	D1	T	D3	D4	D5	L1	L2	L3	L4	L5	S1	S2	S3	Weight g/1 piece	Order code*	PN (bar) ¹⁾		
																CF	A3C	71
L ³⁾	06	G 1/8 A	4	4	14	19	12.0	34.5	8	27	12	14	14	55	ET06LREDOMD	500	315	315
	08	G 1/4 A	6	6	19	21	14.0	37.5	12	29	12	17	19	80	ET08LREDOMD	500	315	315
	10	G 1/4 A	8	6	19	22	15.0	40.0	12	30	14	19	19	98	ET10LREDOMD	500	315	315
	12	G 3/8 A	10	9	22	24	17.0	42.0	12	32	17	22	22	136	ET12LREDOMD	400	315	315
	15	G 1/2 A	12	11	27	28	21.0	46.5	14	36	19	27	27	224	ET15LREDOMD	400	315	315
	18	G 1/2 A	15	14	27	31	23.5	50.0	14	40	24	32	27	306	ET18LREDOMD	400	315	315
	22	G 3/4 A	19	18	32	35	27.5	55.0	16	44	27	36	32	423	ET22LREDOMD	250	160	160
	28	G 1 A	24	23	40	38	30.5	59.0	18	47	36	41	41	608	ET28LREDOMD	250	160	160
	35	G 1 1/4 A	30	30	50	45	34.5	68.5	20	56	41	50	50	920	ET35LREDOMD	250	160	160
	42	G 1 1/2 A	36	36	55	51	40.0	75.0	22	63	50	60	55	1466	ET42LREDOMD	250	160	160
S ⁴⁾	06	G 1/4 A	4	4	19	23	16.0	40.0	12	31	12	17	19	98	ET06SREDOMD	800	630	630
	08	G 1/4 A	5	5	19	24	17.0	42.5	12	32	14	19	19	125	ET08SREDOMD	800	630	630
	10	G 3/8 A	6	7	22	25	17.5	45.0	12	34	17	22	22	169	ET10SREDOMD	800	630	630
	12	G 3/8 A	8	8	22	29	21.5	48.0	12	38	17	24	22	198	ET12SREDOMD	630	630	630
	14	G 1/2 A	9	10	27	30	22.0	54.0	14	40	19	27	27	287	ET14SREDOMD	630	630	630
	16	G 1/2 A	12	12	27	33	24.5	55.0	14	43	24	30	27	348	ET16SREDOMD	630	400	400
	20	G 3/4 A	16	16	32	37	26.5	65.0	16	48	27	36	32	498	ET20SREDOMD	420	400	400
	25	G 1 A	20	20	40	42	30.0	73.0	18	54	36	46	41	918	ET25SREDOMD	420	400	400
	30	G 1 1/4 A	25	25	50	49	35.5	78.5	20	62	41	50	50	1324	ET30SREDOMD	420	400	400
	38	G 1 1/2 A	32	32	55	57	41.0	89.0	22	72	50	60	55	2025	ET38SREDOMD	420	315	315

¹⁾ Pressure shown = item deliverable

³⁾ L = light series; ⁴⁾ S = heavy series

$\frac{PN(\text{bar})}{10} = PN(\text{MPa})$

Delivery without nut and ring. Information on ordering complete fittings or alternative sealing materials see page 17.

Order code suffixes			
Material	Suffix surface and material	Example	Standard sealing material (no additional suffix needed)
Steel, zinc plated, chrome ⁶⁾ -free	CF	ET16SREDOMDCF	NBR
Steel, zinc yellow plated	A3C	ET16SREDOMDA3C	NBR
Stainless Steel	71	ET16SREDOMD71	VIT

*Please add the **suffixes** below according to the material/surface required.

EL-M-ED Assembled adjustable swivel run tee

EO 24° cone end / Male metric thread – ED-seal (ISO 9974)

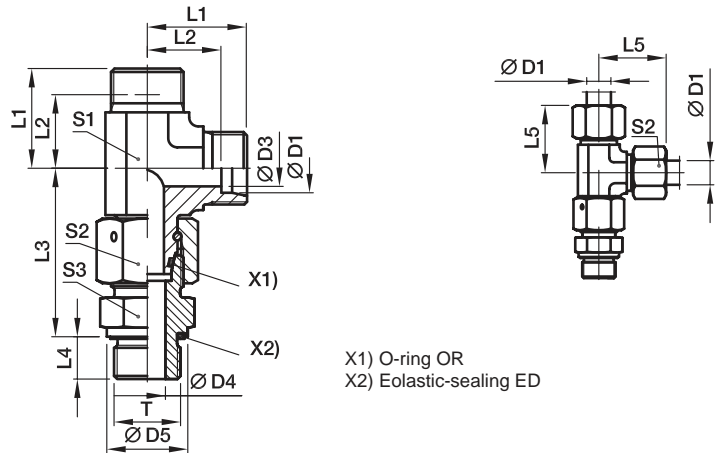

X1) O-ring OR
X2) Eolastic-sealing ED

Series	D1	T	D3	D4	D5	L1	L2	L3	L4	L5	S1	S2	S3	Weight g/1 piece	Order code*	PN (bar) ¹⁾		
																CF	A3C	71
L ³⁾	06	M 10 1	4	4	14	19	12.0	34.5	8	27	12	14	14	55	EL06LMEDOMD	500	315	315
	08	M 12 1.5	6	6	17	21	14.0	37.5	12	29	12	17	17	75	EL08LMEDOMD	500	315	315
	10	M 14 1.5	8	7	19	22	15.0	40.0	12	30	14	19	19	97	EL10LMEDOMD	500	315	315
	12	M 16 1.5	10	9	22	24	17.0	42.0	12	32	17	22	22	135	EL12LMEDOMD	400	315	315
	15	M 18 1.5	12	11	24	28	21.0	46.0	12	36	19	27	24	201	EL15LMEDOMD	400	315	315
	18	M 22 1.5	15	14	27	31	23.5	50.0	14	40	24	32	27	308	EL18LMEDOMD	400	315	315
	22	M 26 1.5	19	18	32	35	27.5	55.0	16	44	27	36	32	404	EL22LMEDOMD	250	160	160
	28	M 33 2	24	23	40	38	30.5	59.0	18	47	36	41	41	605	EL28LMEDOMD	250	160	160
	35	M 42 2	30	30	50	45	34.5	68.5	20	56	41	50	50	947	EL35LMEDOMD	250	160	160
	42	M 48 2	36	36	55	51	40.0	75.0	22	63	50	60	55	1497	EL42LMEDOMD	250	160	160
S ⁴⁾	06	M 12 1.5	4	4	17	23	16.0	40.0	12	31	12	17	17	91	EL06SMEDOMD	800	630	630
	08	M 14 1.5	5	5	19	24	17.0	42.5	12	32	14	19	19	126	EL08SMEDOMD	800	630	630
	10	M 16 1.5	6	7	22	25	17.5	45.0	12	34	17	22	22	169	EL10SMEDOMD	800	630	630
	12	M 18 1.5	8	8	24	29	21.5	48.0	12	38	17	24	24	206	EL12SMEDOMD	630	630	630
	14	M 20 1.5	9	10	26	30	22.0	54.0	14	40	19	27	27	275	EL14SMEDOMD	630	630	630
	16	M 22 1.5	12	12	27	33	24.5	55.0	14	43	24	30	27	354	EL16SMEDOMD	630	400	400
	20	M 27 2	16	16	32	37	26.5	65.0	16	48	27	36	32	526	EL20SMEDOMD	420	400	400
	25	M 33 2	20	20	40	42	30.0	73.0	18	54	36	46	41	919	EL25SMEDOMD	420	400	400
	30	M 42 2	25	25	50	49	35.5	78.5	20	62	41	50	50	1328	EL30SMEDOMD	420	400	400
	38	M 48 2	32	32	55	57	41.0	89.0	22	72	50	60	55	2039	EL38SMEDOMD	420	315	315

¹⁾ Pressure shown = item deliverable

³⁾ L = light series; ⁴⁾ S = heavy series

$\frac{PN(\text{bar})}{10} = PN(\text{MPa})$

Delivery without nut and ring. Information on ordering complete fittings or alternative sealing materials see page 17.

*Please add the **suffixes** below according to the material/surface required.

Order code suffixes			
Material	Suffix surface and material	Example	Standard sealing material (no additional suffix needed)
Steel, zinc plated, chrome ⁶⁾ -free	CF	EL16SMEDOMDCF	NBR
Steel, zinc yellow plated	A3C	EL16SMEDOMDA3C	NBR
Stainless Steel	71	EL16SMEDOMD71	VIT

EL-R-ED Assembled adjustable swivel run tee

EO 24° cone end / Male BSPP thread – ED-seal (ISO 1179)

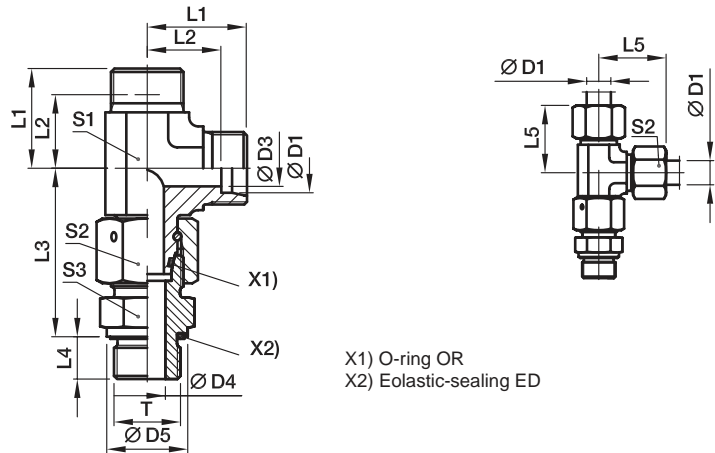

X1) O-ring OR
X2) Eolastic-sealing ED

Series	D1	T	D3	D4	D5	L1	L2	L3	L4	L5	S1	S2	S3	Weight g/1 piece	Order code*	PN (bar) ¹⁾		
																CF	A3C	71
L ³⁾	06	G 1/8 A	4	4	14	19	12.0	34.5	8	27	12	14	14	55	EL06LREDOMD	500	315	315
	08	G 1/4 A	6	6	19	21	14.0	37.5	12	29	12	17	19	80	EL08LREDOMD	500	315	315
	10	G 1/4 A	8	6	19	22	15.0	40.0	12	30	14	19	19	97	EL10LREDOMD	500	315	315
	12	G 3/8 A	10	9	22	24	17.0	42.0	12	32	17	22	22	137	EL12LREDOMD	400	315	315
	15	G 1/2 A	12	11	27	28	21.0	46.5	14	36	19	27	27	222	EL15LREDOMD	400	315	315
	18	G 1/2 A	15	14	27	31	23.5	50.0	14	40	24	32	27	304	EL18LREDOMD	400	315	315
	22	G 3/4 A	19	18	32	35	27.5	55.0	16	44	27	36	32	404	EL22LREDOMD	250	160	160
	28	G 1 A	24	23	40	38	30.5	59.0	18	47	36	41	41	606	EL28LREDOMD	250	160	160
	35	G 1 1/4 A	30	30	50	45	34.5	68.5	20	56	41	50	50	938	EL35LREDOMD	250	160	160
	42	G 1 1/2 A	36	36	55	51	40.0	75.0	22	63	50	60	55	1485	EL42LREDOMD	250	160	160
S ⁴⁾	06	G 1/4 A	4	4	19	23	16.0	40.0	12	31	12	17	19	97	EL06SREDOMD	800	630	630
	08	G 1/4 A	5	5	19	24	17.0	42.5	12	32	14	19	19	125	EL08SREDOMD	800	630	630
	10	G 3/8 A	6	7	22	25	17.5	45.0	12	34	17	22	22	171	EL10SREDOMD	800	630	630
	12	G 3/8 A	8	8	22	29	21.5	48.0	12	38	17	24	22	198	EL12SREDOMD	630	630	630
	14	G 1/2 A	9	10	27	30	22.0	54.0	14	40	19	27	27	269	EL14SREDOMD	630	630	630
	16	G 1/2 A	12	12	27	33	24.5	55.0	14	43	24	30	27	350	EL16SREDOMD	630	400	400
	20	G 3/4 A	16	16	32	37	26.5	65.0	16	48	27	36	32	524	EL20SREDOMD	420	400	400
	25	G 1 A	20	20	40	42	30.0	73.0	18	54	36	46	41	921	EL25SREDOMD	420	400	400
	30	G 1 1/4 A	25	25	50	49	35.5	78.5	20	62	41	50	50	1324	EL30SREDOMD	420	400	400
	38	G 1 1/2 A	32	32	55	57	41.0	89.0	22	72	50	60	55	2033	EL38SREDOMD	420	315	315

¹⁾ Pressure shown = item deliverable

³⁾ L = light series; ⁴⁾ S = heavy series

$\frac{PN(\text{bar})}{10} = PN(\text{MPa})$

Delivery without nut and ring. Information on ordering complete fittings or alternative sealing materials see page 17.

*Please add the **suffixes** below according to the material/surface required.

Order code suffixes			
Material	Suffix surface and material	Example	Standard sealing material (no additional suffix needed)
Steel, zinc plated, chrome ⁶⁾ -free	CF	EL16SREDOMDCF	NBR
Steel, zinc yellow plated	A3C	EL16SREDOMDA3C	NBR
Stainless Steel	71	EL16SREDOMD71	VIT

EVW-M Assembled adjustable standpipe elbow

EO 24° cone end / Male metric thread – metal sealing edge (ISO 9974)

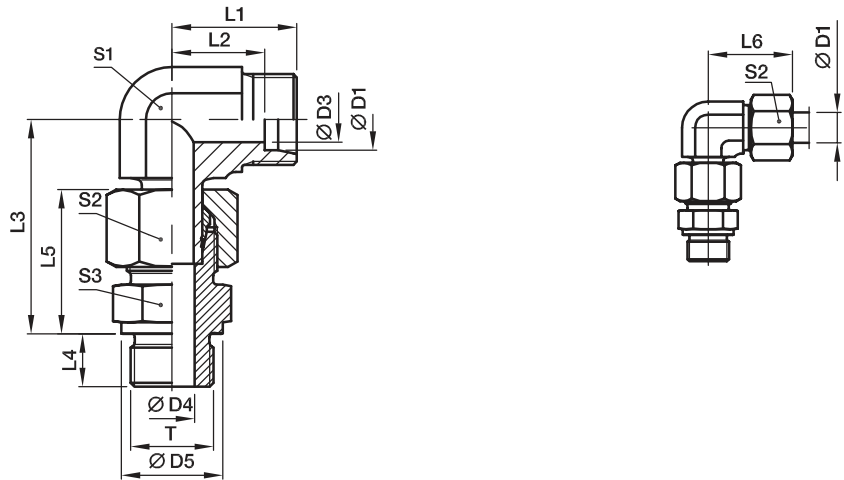

Pre-assembled, complete with straight male stud connector (with cutting face DIN 3852, type B). Final assembly (in appropriate body) at least 1/4 turn beyond the point of clearly perceptible resistance.

Series	D1	T	D3	D4	D5	L1	L2	L3	L4	L5	L6	S1	S2	S3	Weight g/1 piece	Order code*	PN (bar) ¹⁾		
																	CF	A3C	71
L ³⁾	06	M 10 1	4	4	14	19	12.0	34.5	8	23	27	12	14	14	41	EVW06LMOMD	315	315	315
	08	M 12 1.5	6	6	17	21	14.0	37.5	12	25	29	12	17	17	63	EVW08LMOMD	315	315	315
	10	M 14 1.5	8	7	19	22	15.0	40.0	12	26	30	14	19	19	83	EVW10LMOMD	315	315	315
	12	M 16 1.5	10	9	21	24	17.0	42.0	12	27	32	17	22	22	107	EVW12LMOMD	315	315	315
	15	M 18 1.5	12	11	23	28	21.0	46.0	12	29	36	19	27	24	170	EVW15LMOMD	250	250	250
	18	M 22 1.5	15	14	27	31	23.5	50.0	14	31	40	24	32	27	265	EVW18LMOMD	250	250	250
	22	M 26 1.5	19	18	31	35	27.5	55.0	16	33	44	27	36	32	355	EVW22LMOMD	160	160	160
	28	M 33 2	24	23	39	38	30.5	59.5	18	34	47	36	41	41	514	EVW28LMOMD	160	160	160
	35	M 42 2	30	30	49	45	34.5	68.5	20	39	56	41	50	50	791	EVW35LMOMD	160	160	160
	42	M 48 2	36	36	55	51	40.0	79.0	22	42	63	50	60	55	1153	EVW42LMOMD	160	160	160
S ⁴⁾	06	M 12 1.5	4	4	17	23	16.0	40.0	12	28	31	12	17	17	73	EVW06SMOMD	400	400	400
	08	M 14 1.5	5	5	19	24	17.0	42.5	12	30	32	14	19	19	100	EVW08SMOMD	400	400	400
	10	M 16 1.5	7	7	21	25	17.5	46.0	12	31	34	17	22	22	133	EVW10SMOMD	400	400	400
	12	M 18 1.5	8	8	23	29	21.5	48.0	12	33	38	17	24	24	174	EVW12SMOMD	400	400	400
	14	M 20 1.5	10	10	25	30	22.0	54.0	14	37	40	19	27	27	229	EVW14SMOMD	400	400	400
	16	M 22 1.5	12	12	27	33	24.5	56.0	14	37	43	24	30	27	309	EVW16SMOMD	400	400	400
	20	M 27 2	16	16	32	37	26.5	65.0	16	42	48	27	36	32	429	EVW20SMOMD	400	400	400
	25	M 33 2	20	20	39	42	30.0	73.0	18	47	54	36	46	41	826	EVW25SMOMD	250	250	250
	30	M 42 2	25	25	49	49	35.5	78.5	20	50	62	41	50	50	1132	EVW30SMOMD	160	160	160
	38	M 48 2	32	32	55	57	41.0	92.5	22	57	72	50	60	55	1874	EVW38SMOMD	160	160	160

¹⁾ Pressure shown = item deliverable

³⁾ L = light series; ⁴⁾ S = heavy series

$\frac{PN(\text{bar})}{10} = PN(\text{MPa})$

Delivery without nut and ring. Information on ordering complete fittings see page 17.

*Please add the **suffixes** below according to the material/surface required.

Order code suffixes		
Material	Suffix surface and material	Example
Steel, zinc plated, chrome ⁶ -free	CF	EVW16SMOMDCF
Steel, zinc yellow plated	A3C	EVW16SMOMDA3C
Stainless Steel	71	EVW16SMOMD71

EVW-R Assembled adjustable standpipe elbow

EO 24° cone end / Male BSPP thread – metal sealing edge (ISO 1179)

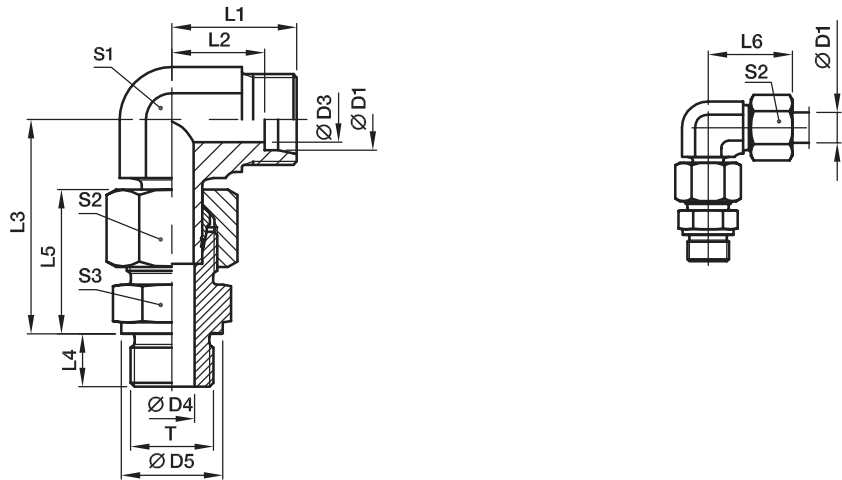

Pre-assembled, complete with straight male stud connector (with cutting face DIN 3852, type B). Final assembly (in appropriate body) at least 1/4 turn beyond the point of clearly perceptible resistance.

Series	D1	T	D3	D4	D5	L1	L2	L3	L4	L5	L6	S1	S2	S3	Weight g/1 piece	Order code*	PN (bar) ¹⁾		
																	CF	A3C	71
L ³⁾	06	G 1/8 A	4	4	14	19	12.0	34.5	8	23	27	12	14	14	47	EVW06LROMD	315	315	315
	08	G 1/4 A	6	6	18	21	14.0	37.5	12	25	29	12	17	19	68	EVW08LROMD	315	315	315
	10	G 1/4 A	8	6	18	22	15.0	40.0	12	26	30	14	19	19	84	EVW10LROMD	315	315	315
	12	G 3/8 A	10	9	22	24	17.0	42.0	12	27	32	17	22	22	118	EVW12LROMD	315	315	315
	15	G 1/2 A	12	11	26	28	21.0	46.5	14	29	36	19	27	27	191	EVW15LROMD	250	250	250
	18	G 1/2 A	15	14	26	31	23.5	50.0	14	31	40	24	32	27	260	EVW18LROMD	250	250	250
	22	G 3/4 A	19	18	32	35	27.5	55.0	16	33	44	27	36	32	355	EVW22LROMD	160	160	160
	28	G 1 A	24	23	39	38	30.5	59.5	18	34	47	36	41	41	542	EVW28LROMD	160	160	160
	35	G 1 1/4 A	30	30	49	45	34.5	68.5	20	39	56	41	50	50	832	EVW35LROMD	160	160	160
	42	G 1 1/2 A	36	36	55	51	40.0	79.0	22	42	63	50	60	55	1303	EVW42LROMD	160	160	160
S ⁴⁾	06	G 1/4 A	4	4	18	23	16.0	40.0	12	28	31	12	17	19	79	EVW06SROMD	400	400	400
	08	G 1/4 A	5	5	18	24	17.0	42.5	12	30	32	14	19	19	98	EVW08SROMD	400	400	400
	10	G 3/8 A	7	7	22	25	17.5	46.0	12	31	34	17	22	22	148	EVW10SROMD	400	400	400
	12	G 3/8 A	8	8	22	29	21.5	48.0	12	33	38	17	24	22	169	EVW12SROMD	400	400	400
	14	G 1/2 A	10	10	26	30	22.0	54.0	14	37	40	19	27	27	230	EVW14SROMD	400	400	400
	16	G 1/2 A	12	12	26	33	24.5	56.0	14	37	43	24	30	27	304	EVW16SROMD	400	400	400
	20	G 3/4 A	16	16	32	37	26.5	65.0	16	42	48	27	36	32	428	EVW20SROMD	400	400	400
	25	G 1 A	20	20	39	42	30.0	73.0	18	47	54	36	46	41	825	EVW25SROMD	250	250	250
	30	G 1 1/4 A	25	25	49	49	35.5	78.5	20	50	62	41	50	50	1134	EVW30SROMD	160	160	160
	38	G 1 1/2 A	32	32	55	57	41.0	92.5	22	57	72	50	60	55	1713	EVW38SROMD	160	160	160

¹⁾ Pressure shown = item deliverable

³⁾ L = light series; ⁴⁾ S = heavy series

$$\frac{\text{PN (bar)}}{10} = \text{PN (MPa)}$$

Delivery without nut and ring. Information on ordering complete fittings see page 17.

*Please add the **suffixes** below according to the material/surface required.

Order code suffixes		
Material	Suffix surface and material	Example
Steel, zinc plated, chrome ⁶ -free	CF	EVW16SROMDCF
Steel, zinc yellow plated	A3C	EVW16SROMDA3C
Stainless Steel	71	EVW16SROMD71

EVT-M Assembled adjustable standpipe branch tee

EO 24° cone end / Male metric thread – metal sealing edge (ISO 9974)

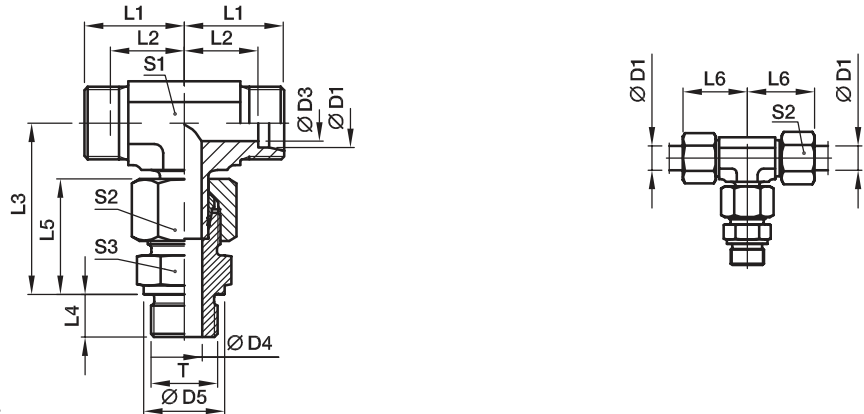

Pre-assembled, complete with straight male stud connector (with cutting face). Final assembly (in appropriate body) at least 1/4 turn beyond the point of clearly perceptible resistance.

Series	D1	T	D3	D4	D5	L1	L2	L3	L4	L5	L6	S1	S2	S3	Weight g/1 piece	Order code*	PN (bar) ¹⁾		
																	CF	A3C	71
L ³⁾	06	M 10 1	4	4	14	19	12.0	34.5	8	23	27	12	14	14	48	EVT06LMOMD	315	315	315
	08	M 12 1.5	6	6	17	21	14.0	37.5	12	25	29	12	17	17	68	EVT08LMOMD	315	315	315
	10	M 14 1.5	8	7	19	22	15.0	40.0	12	26	30	14	19	19	88	EVT10LMOMD	315	315	315
	12	M 16 1.5	10	9	21	24	17.0	43.0	12	27	32	17	22	22	116	EVT12LMOMD	315	315	315
	15	M 18 1.5	12	11	23	28	21.0	46.0	12	29	36	19	27	24	185	EVT15LMOMD	250	250	250
	18	M 22 1.5	15	14	27	31	23.5	50.0	14	31	40	24	32	27	272	EVT18LMOMD	250	250	250
	22	M 26 1.5	19	18	31	35	27.5	55.5	16	33	44	27	36	32	367	EVT22LMOMD	160	160	160
	28	M 33 2	24	23	39	38	30.5	61.0	18	34	47	36	41	41	565	EVT28LMOMD	160	160	160
	35	M 42 2	30	30	49	45	34.5	72.0	20	39	56	41	50	50	905	EVT35LMOMD	160	160	160
	42	M 48 2	36	36	55	51	40.0	79.0	22	42	63	50	60	55	1282	EVT42LMOMD	160	160	160
S ⁴⁾	06	M 12 1.5	4	4	17	23	16.0	40.0	12	28	31	12	17	17	85	EVT06SMOMD	400	400	400
	08	M 14 1.5	5	5	19	24	17.0	44.0	12	30	32	14	19	19	118	EVT08SMOMD	400	400	400
	10	M 16 1.5	7	7	21	25	17.5	47.0	12	31	34	17	22	22	149	EVT10SMOMD	400	400	400
	12	M 18 1.5	8	8	23	29	21.5	50.0	12	33	38	17	24	24	200	EVT12SMOMD	400	400	400
	14	M 20 1.5	10	10	25	30	22.0	54.0	14	37	40	19	27	27	264	EVT14SMOMD	400	400	400
	16	M 22 1.5	12	12	27	33	24.5	55.0	14	37	43	24	30	27	327	EVT16SMOMD	400	400	400
	20	M 27 2	16	16	32	37	26.5	65.0	16	42	48	27	36	32	482	EVT20SMOMD	400	400	400
	25	M 33 2	20	20	39	42	30.0	73.5	18	47	54	36	46	41	906	EVT25SMOMD	250	250	250
	30	M 42 2	25	25	49	49	35.5	80.0	20	50	62	41	50	50	1274	EVT30SMOMD	160	160	160
	38	M 48 2	32	32	55	57	41.0	92.5	22	57	72	50	60	55	1928	EVT38SMOMD	160	160	160

¹⁾ Pressure shown = item deliverable

³⁾ L = light series; ⁴⁾ S = heavy series

$\frac{PN(\text{bar})}{10} = PN(\text{MPa})$

Delivery without nut and ring. Information on ordering complete fittings see page 17.

*Please add the **suffixes** below according to the material/surface required.

Order code suffixes		
Material	Suffix surface and material	Example
Steel, zinc plated, chrome ⁶ -free	CF	EVT16SMOMDCF
Steel, zinc yellow plated	A3C	EVT16SMOMDA3C
Stainless Steel	71	EVT16SMOMD71

EVT-R Assembled adjustable standpipe branch tee

EO 24° cone end / Male BSPP thread – metal sealing edge (ISO 1179)

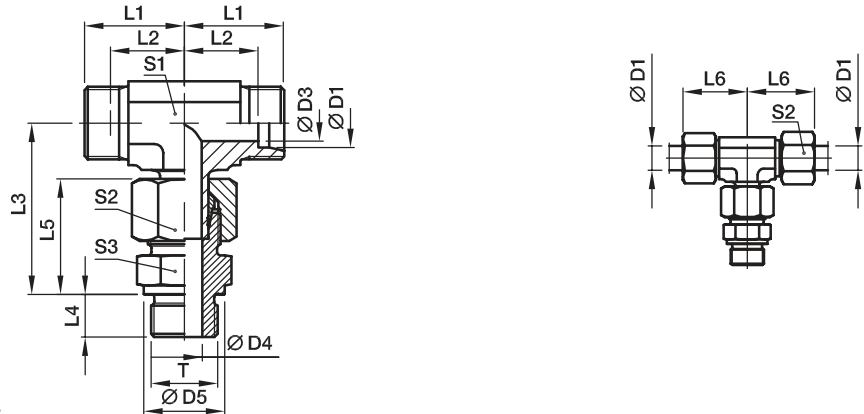

Pre-assembled, complete with straight male stud connector (with cutting face). Final assembly (in appropriate body) at least 1/4 turn beyond the point of clearly perceptible resistance.

Series	D1	T	D3	D4	D5	L1	L2	L3	L4	L5	L6	S1	S2	S3	Weight g/1 piece	Order code*	PN (bar) ¹⁾		
																	CF	A3C	71
L ³⁾	06	G 1/8 A	4	4	14	19	12.0	34.5	8	23	27	12	14	14	48	EVT06LROMD	315	315	315
	08	G 1/4 A	6	6	18	21	14.0	37.5	12	25	29	12	17	19	73	EVT08LROMD	315	315	315
	10	G 1/4 A	8	6	18	22	15.0	40.0	12	26	30	14	19	19	85	EVT10LROMD	315	315	315
	12	G 3/8 A	10	9	22	24	17.0	43.0	12	27	32	17	22	22	118	EVT12LROMD	315	315	315
	15	G 1/2 A	12	11	26	28	21.0	46.5	14	29	36	19	27	27	206	EVT15LROMD	250	250	250
	18	G 1/2 A	15	14	26	31	23.5	50.0	14	31	40	24	32	27	267	EVT18LROMD	250	250	250
	22	G 3/4 A	19	18	32	35	27.5	55.5	16	33	44	27	36	32	367	EVT22LROMD	160	160	160
	28	G 1 A	24	23	39	38	30.5	61.0	18	34	47	36	41	41	565	EVT28LROMD	160	160	160
	35	G 1 1/4 A	30	30	49	45	34.5	72.0	20	39	56	41	50	50	901	EVT35LROMD	160	160	160
	42	G 1 1/2 A	36	36	55	51	40.0	79.0	22	42	63	50	60	55	1277	EVT42LROMD	160	160	160
S ⁴⁾	06	G 1/4 A	4	4	18	23	16.0	40.0	12	28	31	12	17	19	90	EVT06SROMD	400	400	400
	08	G 1/4 A	5	5	18	24	17.0	44.0	12	30	32	14	19	19	116	EVT08SROMD	400	400	400
	10	G 3/8 A	7	7	22	25	17.5	47.0	12	31	34	17	22	22	151	EVT10SROMD	400	400	400
	12	G 3/8 A	8	8	22	29	21.5	50.0	12	33	38	17	24	22	190	EVT12SROMD	400	400	400
	14	G 1/2 A	10	10	26	30	22.0	54.0	14	37	40	19	27	27	265	EVT14SROMD	400	400	400
	16	G 1/2 A	12	12	26	33	24.5	55.0	14	37	43	24	30	27	322	EVT16SROMD	400	400	400
	20	G 3/4 A	16	16	32	37	26.5	65.0	16	42	48	27	36	32	500	EVT20SROMD	400	400	400
	25	G 1 A	20	20	39	42	30.0	73.5	18	47	54	36	46	41	905	EVT25SROMD	250	250	250
	30	G 1 1/4 A	25	25	49	49	35.5	80.0	20	50	62	41	50	50	1275	EVT30SROMD	160	160	160
	38	G 1 1/2 A	32	32	55	57	41.0	92.5	22	57	72	50	60	55	1920	EVT38SROMD	160	160	160

¹⁾ Pressure shown = item deliverable

³⁾ L = light series; ⁴⁾ S = heavy series

$$\frac{\text{PN (bar)}}{10} = \text{PN (MPa)}$$

Delivery without nut and ring. Information on ordering complete fittings see page 17.

*Please add the **suffixes** below according to the material/surface required.

Order code suffixes		
Material	Suffix surface and material	Example
Steel, zinc plated, chrome ⁶ -free	CF	EVT16SROMDCF
Steel, zinc yellow plated	A3C	EVT16SROMDA3C
Stainless Steel	71	EVT16SROMD71

EVL-M Assembled adjustable standpipe run tee

EO 24° cone end / Male metric thread – metal sealing edge (ISO 9974)

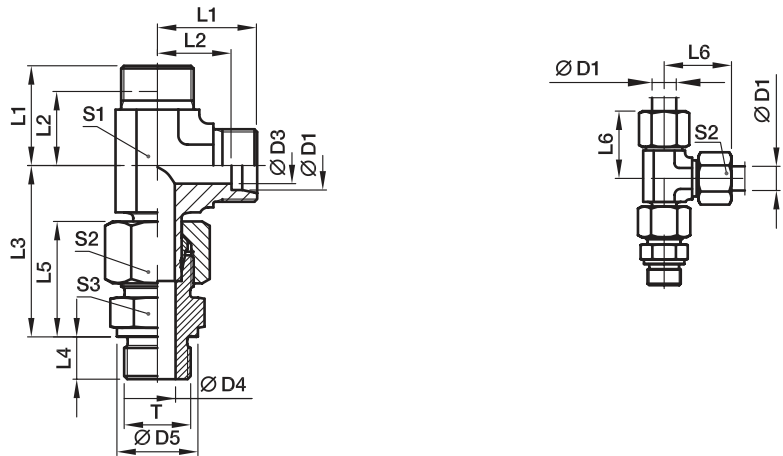

Pre-assembled, complete with straight male stud connector (with cutting face). Final assembly (in appropriate body) at least 1/4 turn beyond the point of clearly perceptible resistance.

Series	D1	T	D3	D4	D5	L1	L2	L3	L4	L5	L6	S1	S2	S3	Weight g/1 piece	Order code*	PN (bar) ¹⁾		
																	CF	A3C	71
L ³⁾	06	M 10 1	4	4	14	19	12.0	34.5	8	23	27	12	14	14	48	EVL06LMOMD	315	315	315
	08	M 12 1.5	6	6	17	21	14.0	37.5	12	25	29	12	17	17	73	EVL08LMOMD	315	315	315
	10	M 14 1.5	8	7	19	22	15.0	40.0	12	26	30	14	19	19	89	EVL10LMOMD	315	315	315
	12	M 16 1.5	10	9	21	24	17.0	43.0	12	27	32	17	22	22	118	EVL12LMOMD	315	315	315
	15	M 18 1.5	12	11	23	28	21.0	46.0	12	29	36	19	27	24	186	EVL15LMOMD	250	250	250
	18	M 22 1.5	15	14	27	31	23.5	50.0	14	31	40	24	32	27	269	EVL18LMOMD	250	250	250
	22	M 26 1.5	19	18	31	35	27.5	55.5	16	33	44	27	36	32	364	EVL22LMOMD	160	160	160
	28	M 33 2	24	23	39	38	30.5	61.0	18	34	47	36	41	41	556	EVL28LMOMD	160	160	160
	35	M 42 2	30	30	49	45	34.5	72.0	20	39	56	41	50	50	900	EVL35LMOMD	160	160	160
	42	M 48 2	36	36	55	51	40.0	79.0	22	42	63	50	60	55	1323	EVL42LMOMD	160	160	160
S ⁴⁾	06	M 12 1.5	4	4	17	23	16.0	40.0	12	28	31	12	17	17	85	EVL06SMOMD	400	400	400
	08	M 14 1.5	5	5	19	24	17.0	44.0	12	30	32	14	19	19	119	EVL08SMOMD	400	400	400
	10	M 16 1.5	7	7	21	25	17.5	47.0	12	31	34	17	22	22	151	EVL10SMOMD	400	400	400
	12	M 18 1.5	8	8	23	29	21.5	50.0	12	33	38	17	24	24	202	EVL12SMOMD	400	400	400
	14	M 20 1.5	10	10	25	30	22.0	54.0	14	37	40	19	27	27	264	EVL14SMOMD	400	400	400
	16	M 22 1.5	12	12	27	33	24.5	56.0	14	37	43	24	30	27	326	EVL16SMOMD	400	400	400
	20	M 27 2	16	16	32	37	26.5	65.0	16	42	48	27	36	32	481	EVL20SMOMD	400	400	400
	25	M 33 2	20	20	39	42	30.0	73.5	18	47	54	36	46	41	904	EVL25SMOMD	250	250	250
	30	M 42 2	25	25	49	49	35.5	80.0	20	50	62	41	50	50	1263	EVL30SMOMD	160	160	160
	38	M 48 2	32	32	55	57	41.0	92.5	22	57	72	50	60	55	1936	EVL38SMOMD	160	160	160

¹⁾ Pressure shown = item deliverable

³⁾ L = light series; ⁴⁾ S = heavy series

$\frac{\text{PN (bar)}}{10} = \text{PN (MPa)}$

Delivery without nut and ring. Information on ordering complete fittings see page 17.

*Please add the **suffixes** below according to the material/surface required.

Order code suffixes		
Material	Suffix surface and material	Example
Steel, zinc plated, chrome ⁶ -free	CF	EVL16SMOMDCF
Steel, zinc yellow plated	A3C	EVL16SMOMDA3C
Stainless Steel	71	EVL16SMOMD71

EVL-R Assembled adjustable standpipe run tee

EO 24° cone end / Male BSPP thread – metal sealing edge (ISO 1179)

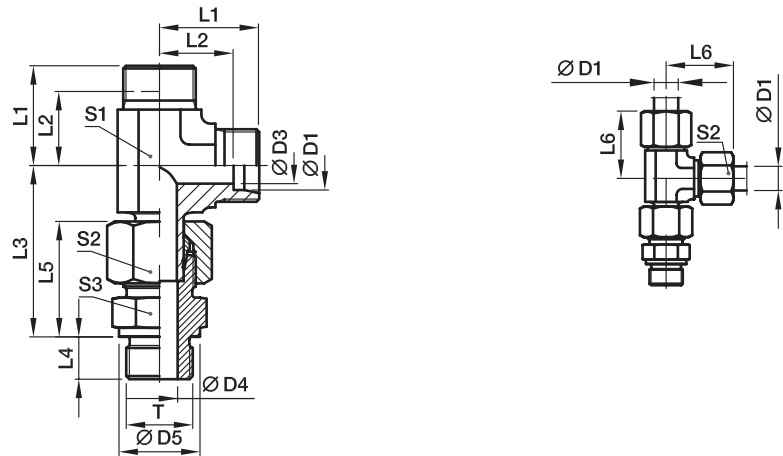

Pre-assembled, complete with straight male stud connector (with cutting face). Final assembly (in appropriate body) at least 1/4 turn beyond the point of clearly perceptible resistance.

Series	D1	T	D3	D4	D5	L1	L2	L3	L4	L5	L6	S1	S2	S3	Weight g/1 piece	Order code*	PN (bar) ¹⁾		
																	CF	A3C	71
L ³⁾	06	G 1/8 A	4	4	14	19	12.0	34.5	8	23	27	12	14	14	48	EVL06LR0MD	315	315	315
	08	G 1/4 A	6	6	18	21	14.0	37.5	12	25	29	12	17	19	73	EVL08LR0MD	315	315	315
	10	G 1/4 A	8	6	18	22	15.0	40.0	12	26	30	14	19	19	87	EVL10LR0MD	315	315	315
	12	G 3/8 A	10	9	22	24	17.0	43.0	12	27	32	17	22	22	120	EVL12LR0MD	315	315	315
	15	G 1/2 A	12	11	26	28	21.0	46.5	14	29	36	19	27	27	207	EVL15LR0MD	250	250	250
	18	G 1/2 A	15	14	26	31	23.5	50.0	14	31	40	24	32	27	264	EVL18LR0MD	250	250	250
	22	G 3/4 A	19	18	32	35	27.5	55.5	16	33	44	27	36	32	365	EVL22LR0MD	160	160	160
	28	G 1 A	24	23	39	38	30.5	61.0	18	34	47	36	41	41	556	EVL28LR0MD	160	160	160
	35	G 1 1/4 A	30	30	49	45	34.5	72.0	20	39	56	41	50	50	895	EVL35LR0MD	160	160	160
	42	G 1 1/2 A	36	36	55	51	40.0	79.0	22	42	63	50	60	55	1318	EVL42LR0MD	160	160	160
S ⁴⁾	06	G 1/4 A	4	4	18	23	16.0	40.0	12	28	31	12	17	19	90	EVL06SR0MD	400	400	400
	08	G 1/4 A	5	5	18	24	17.0	44.0	12	30	32	14	19	19	117	EVL08SR0MD	400	400	400
	10	G 3/8 A	7	7	22	25	17.5	47.0	12	31	34	17	22	22	153	EVL10SR0MD	400	400	400
	12	G 3/8 A	8	8	22	29	21.5	50.0	12	33	38	17	24	22	192	EVL12SR0MD	400	400	400
	14	G 1/2 A	10	10	26	30	22.0	54.0	14	37	40	19	27	27	266	EVL14SR0MD	400	400	400
	16	G 1/2 A	12	12	26	33	24.5	56.0	14	37	43	24	30	27	321	EVL16SR0MD	400	400	400
	20	G 3/4 A	16	16	32	37	26.5	65.0	16	42	48	27	36	32	480	EVL20SR0MD	400	400	400
	25	G 1 A	20	20	39	42	30.0	73.5	18	47	54	36	46	41	903	EVL25SR0MD	250	250	250
	30	G 1 1/4 A	25	25	49	49	35.5	80.0	20	50	62	41	50	50	1265	EVL30SR0MD	160	160	160
	38	G 1 1/2 A	32	32	55	57	41.0	92.5	22	57	72	50	60	55	1928	EVL38SR0MD	160	160	160

¹⁾ Pressure shown = item deliverable

³⁾ L = light series; ⁴⁾ S = heavy series

$$\frac{\text{PN (bar)}}{10} = \text{PN (MPa)}$$

Delivery without nut and ring. Information on ordering complete fittings see page 17.

*Please add the **suffixes** below according to the material/surface required.

Order code suffixes		
Material	Suffix surface and material	Example
Steel, zinc plated, chrome ⁶ -free	CF	EVL16SR0MDCF
Steel, zinc yellow plated	A3C	EVL16SR0MDA3C
Stainless Steel	71	EVL16SR0MD71

WEE-OR Adjustable locknut elbow

EO 24° cone end / Adjustable metric thread – O-ring (ISO 6149)

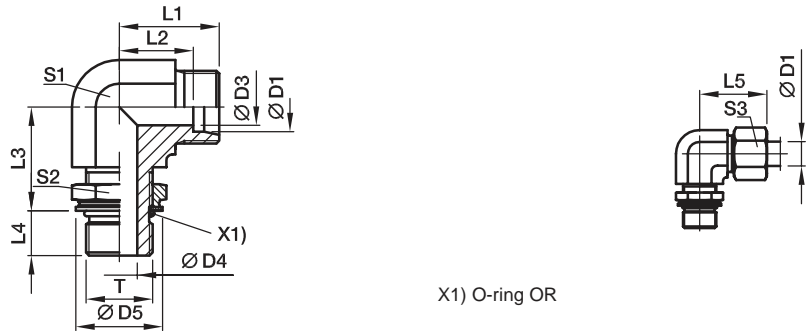

X1) O-ring OR

Series	D1	T	D3	D4	D5	L1	L2	L3	L4	L5	S1	S2	S3	Weight g/1 piece	Order code*	PN (bar) ¹⁾	
																CF	A3C
LL ²⁾	04	M8 1	3.0	4.5	13.3	15	11.3	19.8	7.1	21	12	12	10	24	WEE04LLMOROMD	100	100
	04	M10 1	3.0	6.0	15.3	15	11.3	19.8	7.1	21	11	14	10	29	WEE04LLM10X10ROMD	100	100
	06	M10 1	4.5	6.0	15.3	15	9.8	19.8	7.1	22	14	14	12	22	WEE06LLMOROMD	100	100
	06	M12 1.5	4.5	7.0	18.6	18	12.8	23.2	9.6	25	14	17	12	42	WEE06LLM12X1.5OROMD	100	100
L ³⁾	06	M10 1	4.0	4.5	15.0	21	14.0	20.0	7.0	29	14	14	14	40	WEE06LMOROMD	315	315
	08	M12 1.5	6.0	6.0	18.0	23	16.0	22.0	10.0	31	14	17	17	48	WEE08LMOROMD	315	315
	10	M14 1.5	8.0	7.5	20.0	24	17.0	25.0	10.0	32	19	19	19	84	WEE10LMOROMD	315	315
	12	M16 1.5	10.0	9.0	23.0	26	19.0	26.0	10.0	34	19	22	22	92	WEE12LMOROMD	315	315
	15	M18 1.5	12.0	11.0	25.0	28	21.0	30.0	11.0	36	22	24	27	128	WEE15LMOROMD	315	315
	18	M22 1.5	15.0	14.0	28.0	31	24.0	33.0	12.0	40	27	27	32	204	WEE18LMOROMD	315	315
	22	M27 2	19.0	18.0	33.0	35	28.0	35.0	14.0	44	30	32	36	269	WEE22LM27X2OROMD	160	160
	28	M33 2	24.0	23.0	41.0	38	31.0	38.0	14.0	47	36	41	41	420	WEE28LMOROMD	160	160
	35	M42 2	30.0	30.0	51.0	48	38.0	48.0	14.0	59	50	50	50	958	WEE35LMOROMD	160	160
	42	M48 2	36.0	36.0	56.0	49	38.0	49.0	16.0	61	50	55	60	844	WEE42LMOROMD	160	160
S ⁴⁾	06	M12 1.5	4.0	4.0	18.0	22	15.0	22.0	10.0	30	14	17	17	55	WEE06SMOROMD	400	400
	08	M14 1.5	5.0	6.0	20.0	24	17.0	26.0	10.0	32	19	19	19	90	WEE08SMOROMD	400	400
	10	M16 1.5	7.0	7.0	23.0	25	18.0	27.0	11.0	34	19	22	22	108	WEE10SMOROMD	400	400
	12	M18 1.5	8.0	9.0	25.0	29	22.0	31.0	12.0	38	22	24	24	154	WEE12SMOROMD	400	400
	16	M22 1.5	12.0	12.0	28.0	33	25.0	35.0	14.0	43	27	27	30	242	WEE16SMOROMD	400	400
	20	M27 2	16.0	15.0	33.0	38	28.0	39.0	16.0	49	30	32	36	354	WEE20SMOROMD	400	400
	25	M33 2	20.0	20.0	41.0	42	30.0	44.0	16.0	54	36	41	46	552	WEE25SMOROMD	315	315
	30	M42 2	25.0	26.0	51.0	49	36.0	51.0	17.0	62	50	50	50	1129	WEE30SMOROMD	250	250
38	M48 2	32.0	32.0	56.0	50	34.0	54.0	19.0	65	50	55	60	1123	WEE38SMOROMD	200	200	

¹⁾ Pressure shown = item deliverable

²⁾ LL = very light series; ³⁾ L = light series; ⁴⁾ S = heavy series

$$\frac{\text{PN (bar)}}{10} = \text{PN (MPa)}$$

Delivery without nut and ring. Information on ordering complete fittings or alternative sealing materials see page I7.

*Please add the **suffixes** below according to the material/surface required.

Order code suffixes			
Material	Suffix surface and material	Example	Standard sealing material (no additional suffix needed)
Steel, zinc plated, chrome ⁶ -free	CF	WEE16SMOROMDCF	NBR
Steel, zinc yellow plated	A3C	WEE16SMOROMDA3C	NBR

WEE-M Adjustable locknut elbow

EO 24° cone end / Adjustable metric thread – O-ring + retaining ring

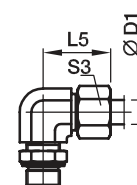
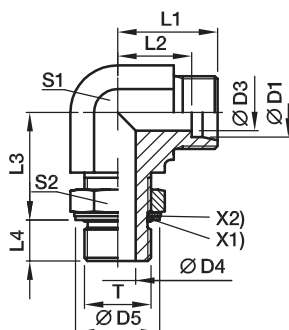

X1) O-ring OR
X2) retaining ring

Series	D1	T	D3	D4	D5	L1	L2	L3	L4	L5	S1	S2	S3	Weight g/1 piece	Order code*	PN (bar) ¹⁾		
																CF	A3C	71
L ³⁾	06	M10 1	4	4.5	15	21	14	20	7	29	14	14	14	39	WEE06LMOMD	315	315	315
	08	M12 1.5	6	6.0	18	23	16	22	10	31	14	17	17	55	WEE08LMOMD	315	315	315
	10	M14 1.5	8	7.5	20	24	17	24	10	32	19	19	19	81	WEE10LMOMD	315	315	315
	12	M16 1.5	10	9.0	23	26	19	25	10	34	19	22	22	92	WEE12LMOMD	315	315	315
	15	M18 1.5	12	11.0	25	28	21	31	11	36	22	24	27	127	WEE15LMOMD	315	315	315
	18	M22 1.5	15	14.0	28	31	24	33	12	40	27	27	32	207	WEE18LMOMD	250	250	250
	22	M27 2	19	18.0	33	35	28	36	14	44	30	32	36	273	WEE22LM27X20MD	160	160	160
	28	M33 2	24	23.0	41	38	31	39	14	47	36	41	41	415	WEE28LMOMD	160	160	160
	35	M42 2	30	30.0	51	48	38	49	14	59	50	50	50	971	WEE35LMOMD	160	160	160
	42	M48 2	36	36.0	56	49	38	50	16	61	50	55	60	914	WEE42LMOMD	160	160	160
S ⁴⁾	06	M12 1.5	4	4.0	18	22	15	22	10	30	14	17	17	55	WEE06SMOMD	315	315	315
	08	M14 1.5	5	6.0	20	24	17	26	10	32	19	19	19	87	WEE08SMOMD	315	315	315
	10	M16 1.5	7	7.0	23	25	18	27	11	34	19	22	22	102	WEE10SMOMD	315	315	315
	12	M18 1.5	8	9.0	25	29	22	31	12	38	22	24	24	146	WEE12SMOMD	315	315	315
	16	M22 1.5	12	12.0	28	33	25	36	14	43	27	27	30	238	WEE16SMOMD	250	250	250
	20	M27 2	16	15.0	33	38	28	39	16	49	30	32	36	348	WEE20SMOMD	250	250	250
	25	M33 2	20	20.0	41	42	30	44	16	54	36	41	46	529	WEE25SMOMD	160	160	160
	30	M42 2	25	26.0	51	49	36	51	17	62	50	50	50	1118	WEE30SMOMD	160	160	160
	38	M48 2	32	32.0	56	50	34	54	19	65	50	55	60	1098	WEE38SMOMD	160	160	160

¹⁾ Pressure shown = item deliverable

³⁾ L = light series; ⁴⁾ S = heavy series

$$\frac{PN \text{ (bar)}}{10} = PN \text{ (MPa)}$$

Delivery without nut and ring. Information on ordering complete fittings or alternative sealing materials see page 17.

*Please add the **suffixes** below according to the material/surface required.

Order code suffixes			
Material	Suffix surface and material	Example	Standard sealing material (no additional suffix needed)
Steel, zinc plated, chrome ⁶⁾ -free	CF	WEE16SMOMDCF	NBR
Steel, zinc yellow plated	A3C	WEE16SMOMDA3C	NBR
Stainless Steel	71	WEE16SMOMD71	VIT

WEE-R Adjustable locknut elbow

EO 24° cone end / Adjustable BSPP thread – O-ring + retaining ring (ISO 1179)
 for ports with small or wide spot face;
 differences in D5 in Stainless Steel are only for ports with wide spot face
 (e.g. WEE16SRBOMD71)

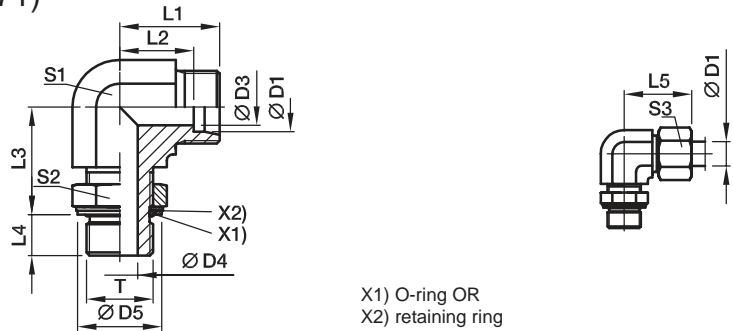

X1) O-ring OR
 X2) retaining ring

Series	D1	T	D3	D4	D5 ⁵⁾	D5 ⁶⁾	L1	L2	L3	L4	L5	S1	S2	S3	Weight g/1 piece	Order code*	PN (bar) ¹⁾		
																	CF	A3C	71
LL ²⁾	04	G 1/8A	3.0	4.5	15		15	11.3	20	7.1	21	11	14	10	27	WEE04LLROMD	250	250	
	06	G 1/8A	4.5	4.5	15		15	11.3	20	7.1	21	11	14	12	27	WEE06LLROMD	250	250	
L ³⁾	06	G 1/8A	4.0	4.5	15	15.0	21	14.0	19	7.0	29	14	14	14	40	WEE06LROMD	315	315	315
	08	G 1/4A	6.0	7.5	20	20.0	23	16.0	23	9.0	31	14	19	17	59	WEE08LROMD	315	315	315
	10	G 1/4A	8.0	7.5	20	20.0	24	17.0	25	9.0	32	19	19	19	82	WEE10LROMD	315	315	315
	12	G 3/8A	10.0	10.0	23	23.5	26	19.0	28	9.0	34	19	22	22	96	WEE12LROMD	250	250	250
	15	G 1/2A	12.0	12.5	28	28.5	28	21.0	30	13.0	36	22	27	27	149	WEE15LROMD	250	250	250
	18	G 1/2A	15.0	12.5	28	28.5	31	24.0	36	13.0	40	27	27	32	221	WEE18LROMD	250	250	250
	22	G 3/4A	19.0	15.5	33	34.5	35	28.0	36	13.0	44	30	36	36	310	WEE22LROMD	160	160	160
	28	G 1A	24.0	21.5	41	43.5	38	31.0	44	15.0	47	36	41	41	455	WEE28LROMD	160	160	160
	35	G 1 1/4A	30.0	27.5	51	52.5	48	38.0	50	15.0	59	50	50	50	1043	WEE35LROMD	160	160	160
	42	G 1 1/2A	36.0	33.0	56	60.0	49	38.0	52	15.0	61	50	55	60	994	WEE42LROMD	160	160	160
S ⁴⁾	06	G 1/4A	4.0	7.5	20	20.0	22	15.0	23	9.0	30	14	19	17	56	WEE06SROMD	315	315	315
	08	G 1/4A	5.0	7.5	20	20.0	24	17.0	27	9.0	32	19	19	19	88	WEE08SROMD	315	315	315
	10	G 3/8A	7.0	10.0	23	23.5	25	18.0	29	9.0	34	19	22	22	98	WEE10SROMD	250	250	250
	12	G 3/8A	8.0	10.0	23	23.5	29	22.0	29	9.0	38	22	22	24	128	WEE12SROMD	250	250	250
	16	G 1/2A	12.0	12.5	28	28.5	33	25.0	36	13.0	43	27	27	30	234	WEE16SROMD	250	250	250
	20	G 3/4A	16.0	15.5	33	34.5	38	28.0	39	12.0	49	30	36	36	344	WEE20SROMD	250	250	250
	25	G 1A	20.0	21.5	41	43.5	42	30.0	44	14.0	54	36	41	46	533	WEE25SROMD	250	250	250
	30	G 1 1/4A	25.0	27.5	51	52.5	49	36.0	49	15.0	62	50	50	50	1085	WEE30SROMD	160	160	160
	38	G 1 1/2A	32.0	33.0	56	60.0	50	34.0	55	15.0	65	50	55	60	1116	WEE38SROMD	160	160	160

1) Pressure shown = item deliverable

2) LL = very light series; 3) L = light series; 4) S = heavy series

$$\frac{PN \text{ (bar)}}{10} = PN \text{ (MPa)}$$

Delivery without nut and ring. Information on ordering complete fittings or alternative sealing materials see page 17.

5) Steel; 6) Stainless Steel

*Please add the **suffixes** below according to the material/surface required.

Order code suffixes			
Material	Suffix surface and material	Example	Standard sealing material (no additional suffix needed)
Steel, zinc plated, chrome ⁵⁾ -free	CF	WEE16SROMDCF	NBR
Steel, zinc yellow plated	A3C	WEE16SROMDA3C	NBR
Stainless Steel	71	WEE16SRBOMD71	VIT

WEE-UNF Adjustable locknut elbow

EO 24° cone end / Adjustable UN/UNF thread – O-ring (ISO 11926)

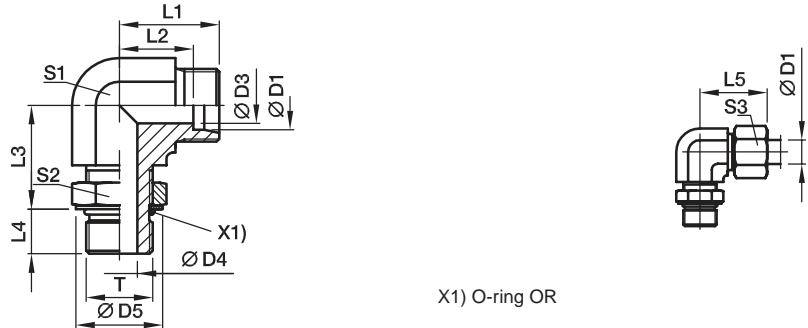

Series	D1	T	D3	D4	D5	L1	L2	L3	L4	L5	S1	S2	S3	Weight g/1 piece	Order code*	PN (bar) ¹⁾	
																CF	A3C
L ³⁾	06	7/16-20 UNF-2A	4	4.5	16.5	21	14	19	10	29	14	14	14	42	WEE06L7/16UNFOMD	315	315
	08	7/16-20 UNF-2A	6	4.5	18.3	23	16	19	10	31	14	14	17	45	WEE08L7/16UNFOMD	315	315
	10	9/16-18 UNF-2A	8	7.5	20.2	24	17	24	10	32	19	17	19	79	WEE10L9/16UNFOMD	315	315
	12	9/16-18 UNF-2A	10	7.5	25.7	26	19	25	11	34	19	17	22	84	WEE12L9/16UNFOMD	315	315
	12	3/4-16 UNF-2A	10	10.0	25.7	26	19	25	13	34	19	22	22	102	WEE12L3/4UNFOMD	315	315
	15	3/4-16 UNF-2A	12	10.0	29.3	28	21	28	13	36	22	22	27	131	WEE15L3/4UNFOMD	315	315
	15	7/8-14 UNF-2A	12	12.5	29.3	28	21	28	15	36	22	27	27	151	WEE15L7/8UNFOMD	315	315
	18	7/8-14 UNF-2A	15	12.5	29.3	31	24	32	15	40	27	27	32	223	WEE18L7/8UNFOMD	315	315
	18	1 1/16-12 UN-2A	15	15.5	29.3	31	24	32	17	40	30	32	32	287	WEE18L11/16UNOMD	315	315
	22	1 1/16-12 UN-2A	19	15.5	36.7	35	28	35	17	44	30	32	36	307	WEE22L11/16UNOMD	160	160
	28	1 5/16-12 UN-2A	24	21.5	44.0	38	31	42	17	47	36	41	41	446	WEE28L15/16UNOMD	160	160
	35	1 5/8-12 UN-2A	30	27.5	55.0	48	38	46	17	59	50	50	50	1043	WEE35L15/8UNOMD	160	160
42	1 7/8-12 UN-2A	36	33.5	55.0	49	38	47	17	61	50	55	60	937	WEE42L17/8UNOMD	160	160	
S ⁴⁾	06	7/16-20 UNF-2A	4	4.5	16.5	22	15	20	12	30	14	14	17	52	WEE06S7/16UNFOMD	400	400
	08	9/16-18 UNF-2A	5	7.5	18.3	24	17	25	12	32	19	17	19	92	WEE08S9/16UNFOMD	400	400
	10	9/16-18 UNF-2A	7	7.5	20.2	25	18	26	12	34	19	17	22	95	WEE10S9/16UNFOMD	400	400
	12	3/4-16 UNF-2A	8	10.0	25.7	29	22	30	14	38	22	22	24	152	WEE12S3/4UNFOMD	400	400
	16	7/8-14 UNF-2A	12	12.5	29.3	33	25	34	16	43	27	27	30	243	WEE16S7/8UNFOMD	400	400
	20	1 1/16-12 UN-2A	16	15.5	36.7	38	28	37	19	49	30	32	36	370	WEE20S11/16UNOMD	400	400
	25	1 1/16-12 UN-2A	20	15.5	44.0	42	30	50	19	54	36	32	46	505	WEE25S11/16UNOMD	400	400
	30	1 5/8-12 UN-2A	25	27.5	55.0	49	36	50	19	62	50	50	50	1105	WEE30S15/8UNOMD	250	250
38	1 7/8-12 UN-2A	32	33.5	55.0	50	34	51	19	65	50	55	60	1106	WEE38S17/8UNOMD	250	250	

¹⁾ Pressure shown = item deliverable

³⁾ L = light series; ⁴⁾ S = heavy series

$$\frac{\text{PN (bar)}}{10} = \text{PN (MPa)}$$

Delivery without nut and ring. Information on ordering complete fittings or alternative sealing materials see page 17.

*Please add the **suffixes** below according to the material/surface required.

Order code suffixes			
Material	Suffix surface and material	Example	Standard sealing material (no additional suffix needed)
Steel, zinc plated, chrome ⁶ -free	CF	WEE16S7/8UNFOMDCF	NBR
Steel, zinc yellow plated	A3C	WEE16S7/8UNFOMDA3C	NBR

TEE-OR Adjustable locknut branch tee

EO 24° cone end / Adjustable metric thread – O-ring (ISO 6149)

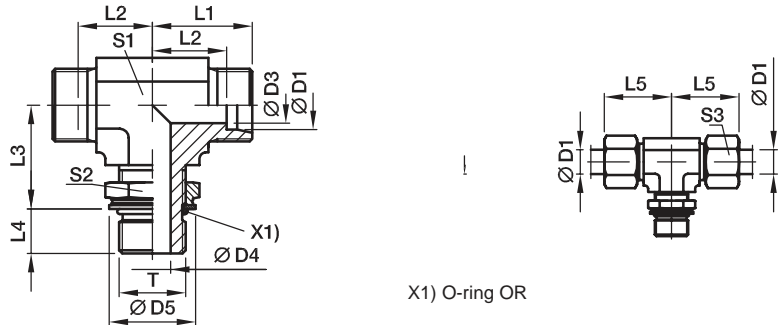

Series	D1	T	D3	D4	D5	L1	L2	L3	L4	L5	S1	S2	S3	Weight g/1 piece	Order code*	PN (bar) ¹⁾	
																CF	A3C
L ³⁾	06	M10 1	4	4.5	15	21	14	20	7	29	14	14	14	53	TEE06LMOROMD	315	315
	08	M12 1.5	6	6.0	18	23	16	22	10	31	14	17	17	63	TEE08LMOROMD	315	315
	10	M14 1.5	8	7.5	20	24	17	25	10	32	19	19	19	111	TEE10LMOROMD	315	315
	12	M16 1.5	10	9.0	23	26	19	26	10	34	19	22	22	110	TEE12LMOROMD	315	315
	15	M18 1.5	12	11.0	25	28	21	30	11	36	22	24	27	163	TEE15LMOROMD	315	315
	18	M22 1.5	15	14.0	28	31	24	33	12	40	27	27	32	272	TEE18LMOROMD	315	315
	22	M27 2	19	18.0	33	35	28	35	14	44	30	32	36	315	TEE22LM27X2OROMD	160	160
	28	M33 2	24	23.0	41	38	31	38	14	47	36	41	41	477	TEE28LMOROMD	160	160
	35	M42 2	30	30.0	51	48	38	48	14	59	50	50	50	477	TEE35LMOROMD	160	160
	42	M48 2	36	36.0	56	49	38	49	16	61	50	55	60	950	TEE42LMOROMD	160	160
S ⁴⁾	06	M12 1.5	4	4.0	18	22	15	22	10	30	14	17	17	72	TEE06SMOROMD	400	400
	08	M14 1.5	5	6.0	20	24	17	26	10	32	19	19	19	118	TEE08SMOROMD	400	400
	10	M16 1.5	7	7.0	23	25	18	27	11	34	19	22	22	131	TEE10SMOROMD	400	400
	12	M18 1.5	8	9.0	25	29	22	31	12	38	22	24	24	192	TEE12SMOROMD	400	400
	16	M22 1.5	12	12.0	28	33	25	35	14	43	27	27	30	295	TEE16SMOROMD	400	400
	20	M27 2	16	15.0	33	38	28	39	16	49	30	32	36	423	TEE20SMOROMD	400	400
	25	M33 2	20	20.0	41	42	30	44	16	54	36	41	46	665	TEE25SMOROMD	315	315
	30	M42 2	25	26.0	51	49	36	51	17	62	50	50	50	1347	TEE30SMOROMD	250	250
38	M48 2	32	32.0	56	50	34	54	19	65	50	55	60	1324	TEE38SMOROMD	200	200	

¹⁾ Pressure shown = item deliverable

³⁾ L = light series; ⁴⁾ S = heavy series

$$\frac{PN \text{ (bar)}}{10} = PN \text{ (MPa)}$$

Delivery without nut and ring. Information on ordering complete fittings or alternative sealing materials see page 17.

*Please add the **suffixes** below according to the material/surface required.

Order code suffixes			
Material	Suffix surface and material	Example	Standard sealing material (no additional suffix needed)
Steel, zinc plated, chrome ⁶⁻ -free	CF	TEE16SMOROMDCF	NBR
Steel, zinc yellow plated	A3C	TEE16SMOROMDA3C	NBR

TEE-M Adjustable locknut branch tee

EO 24° cone end / Adjustable metric thread – O-ring + retaining ring

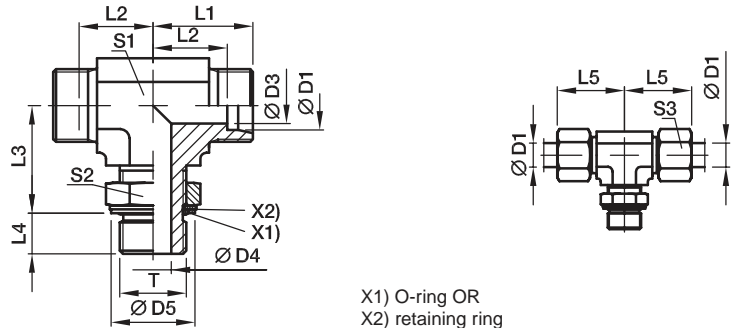

X1) O-ring OR
X2) retaining ring

Series	D1	T	D3	D4	D5	L1	L2	L3	L4	L5	S1	S2	S3	Weight g/1 piece	Order code*	PN (bar) ¹⁾		
																CF	A3C	71
L ³⁾	06	M10 1	4	4.5	15	21	14	20	7	29	14	14	14	52	TEE06LMOMD	315	315	315
	08	M12 1.5	6	6.0	18	23	16	22	10	31	14	17	17	63	TEE08LMOMD	315	315	315
	10	M14 1.5	8	7.5	20	24	17	25	9	32	19	19	19	99	TEE10LMOMD	315	315	315
	12	M16 1.5	10	9.0	23	26	19	26	9	34	19	22	22	106	TEE12LMOMD	315	315	315
	15	M18 1.5	12	11.0	25	28	21	30	11	36	22	24	27	162	TEE15LMOMD	315	315	315
	18	M22 1.5	15	14.0	28	31	24	33	11	40	27	27	32	248	TEE18LMOMD	250	250	250
	22	M27 2	19	18.0	33	35	28	35	14	44	30	32	36	319	TEE22LM27X20MD	160	160	160
	28	M33 2	24	23.0	41	38	31	38	14	47	36	41	41	472	TEE28LMOMD	160	160	160
	35	M42 2	30	30.0	51	48	38	48	14	59	50	50	50	1147	TEE35LMOMD	160	160	160
	42	M48 2	36	36.0	56	49	38	49	16	61	50	55	60	1020	TEE42LMOMD	160	160	160
S ⁴⁾	06	M12 1.5	4	4.0	18	22	15	22	10	30	14	17	17	73	TEE06SMOMD	315	315	315
	08	M14 1.5	5	6.0	20	24	17	26	10	32	19	19	19	124	TEE08SMOMD	315	315	315
	10	M16 1.5	7	7.0	23	25	18	27	11	34	19	22	22	125	TEE10SMOMD	315	315	315
	12	M18 1.5	8	9.0	25	29	22	31	12	38	22	24	24	184	TEE12SMOMD	315	315	315
	16	M22 1.5	12	12.0	28	33	25	35	14	43	27	27	30	291	TEE16SMOMD	250	250	250
	20	M27 2	16	15.0	33	38	28	39	16	49	30	32	36	418	TEE20SMOMD	250	250	250
	25	M33 2	20	20.0	41	42	30	44	16	54	36	41	46	642	TEE25SMOMD	160	160	160
	30	M42 2	25	26.0	51	49	36	51	17	62	50	50	50	1335	TEE30SMOMD	160	160	160
	38	M48 2	32	32.0	56	50	34	54	19	65	50	55	60	1300	TEE38SMOMD	160	160	160

¹⁾ Pressure shown = item deliverable

³⁾ L = light series; ⁴⁾ S = heavy series

$$\frac{PN \text{ (bar)}}{10} = PN \text{ (MPa)}$$

Delivery without nut and ring. Information on ordering complete fittings or alternative sealing materials see page 17.

*Please add the **suffixes** below according to the material/surface required.

Order code suffixes			
Material	Suffix surface and material	Example	Standard sealing material (no additional suffix needed)
Steel, zinc plated, chrome ⁶⁾ -free	CF	TEE16SMOMDCF	NBR
Steel, zinc yellow plated	A3C	TEE16SMOMDA3C	NBR
Stainless Steel	71	TEE16SMOMD71	VIT

TEE-R Adjustable locknut branch tee

EO 24° cone end / Adjustable BSPP thread – O-ring + retaining ring (ISO 1179)
 for ports with small or wide spot face;
 differences in D5 in Stainless Steel are only for ports with wide spot face
 (e. g. TEE16SRBOMD71)

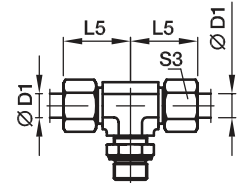
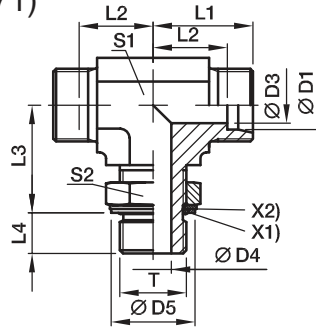

X1) O-ring OR
 X2) retaining ring

Series	D1	T	D3	D4	D5 ⁵⁾	D5 ⁶⁾	L1	L2	L3	L4	L5	S1	S2	S3	Weight g/1 piece	Order code*	PN (bar) ¹⁾		
																	CF	A3C	71
L ³⁾	06	G 1/8A	4	4.5	15	15.0	21	14	19	7	29	14	14	14	52	TEE06LROMD	315	315	315
	08	G 1/4A	6	7.5	20	20.0	23	16	23	9	31	14	19	17	75	TEE08LROMD	315	315	315
	10	G 1/4A	8	7.5	20	20.0	24	17	25	9	32	19	19	19	107	TEE10LROMD	315	315	315
	12	G 3/8A	10	10.0	23	23.5	26	19	28	9	34	19	22	22	114	TEE12LROMD	250	250	250
	15	G 1/2A	12	12.5	28	28.5	28	21	30	13	36	22	27	27	183	TEE15LROMD	250	250	250
	18	G 1/2A	15	12.5	28	28.5	31	24	36	13	40	27	27	32	271	TEE18LROMD	250	250	250
	22	G 3/4A	19	15.5	33	34.5	35	28	36	13	44	30	36	36	357	TEE22LROMD	160	160	160
	28	G 1A	24	21.5	41	43.5	38	31	44	15	47	36	41	41	545	TEE28LROMD	160	160	160
	35	G 1 1/4A	30	27.5	51	52.5	48	38	50	15	59	50	50	50	1188	TEE35LROMD	160	160	160
	42	G 1 1/2A	36	33.0	56	60.0	49	38	52	15	61	50	50	60	1122	TEE42LROMD	160	160	160
S ⁴⁾	06	G 1/4A	4	7.5	20	20.0	22	15	23	9	30	14	19	17	73	TEE06SROMD	315	315	315
	08	G 1/4A	5	7.5	20	20.0	24	17	27	9	32	19	19	19	115	TEE08SROMD	315	315	315
	10	G 3/8A	7	10.0	23	23.5	25	18	29	9	34	19	22	22	126	TEE10SROMD	250	250	250
	12	G 3/8A	8	10.0	23	23.5	29	22	29	9	38	22	22	24	171	TEE12SROMD	250	250	250
	16	G 1/2A	12	12.5	28	28.5	33	25	36	13	43	27	27	30	292	TEE16SROMD	250	250	250
	20	G 3/4A	16	15.5	33	34.5	38	28	39	12	49	30	36	36	416	TEE20SROMD	250	250	250
	25	G 1A	20	21.5	41	43.5	42	30	44	14	54	36	41	46	644	TEE25SROMD	250	250	250
	30	G 1 1/4A	25	27.5	51	52.5	49	36	49	15	62	50	50	50	1285	TEE30SROMD	160	160	160
	38	G 1 1/2A	32	33.0	56	60.0	50	34	55	15	65	50	55	60	1272	TEE38SROMD	160	160	160

¹⁾ Pressure shown = item deliverable

³⁾ L = light series; ⁴⁾ S = heavy series

$\frac{PN \text{ (bar)}}{10} = PN \text{ (MPa)}$

Delivery without nut and ring. Information on ordering complete fittings or alternative sealing materials see page 17.

⁵⁾ Steel; ⁶⁾ Stainless Steel

*Please add the **suffixes** below according to the material/surface required.

Order code suffixes			
Material	Suffix surface and material	Example	Standard sealing material (no additional suffix needed)
Steel, zinc plated, chrome ⁶⁾ -free	CF	TEE16SROMDCF	NBR
Steel, zinc yellow plated	A3C	TEE16SROMDA3C	NBR
Stainless Steel	71	TEE16SRBOMD71	VIT

TEE-UNF Adjustable locknut branch tee

EO 24° cone end / Adjustable UN/UNF thread – O-ring (ISO 11926)

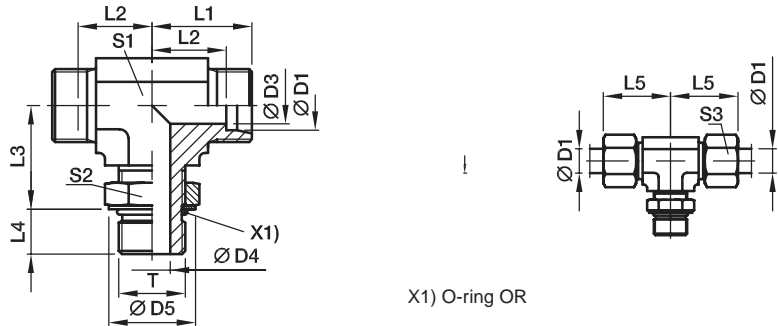

Series	D1	T	D3	D4	D5	L1	L2	L3	L4	L5	S1	S2	S3	Weight g/1 piece	Order code*	PN (bar) ¹⁾	
																CF	A3C
L ³⁾	06	7/16-20 UNF-2A	4	4.5	16.5	21	14	19	10	29	14	14	14	58	TEE06L7/16UNFOMD	315	315
	08	7/16-20 UNF-2A	6	4.5	18.3	23	16	19	10	31	14	14	17	60	TEE08L7/16UNFOMD	315	315
	10	9/16-18 UNF-2A	8	7.5	20.2	24	17	24	10	32	19	17	19	102	TEE10L9/16UNFOMD	315	315
	12	9/16-18 UNF-2A	10	7.5	25.7	26	19	25	11	34	19	17	22	103	TEE12L9/16UNFOMD	315	315
	12	3/4-16 UNF-2A	10	10.0	25.7	26	19	25	13	34	19	22	22	118	TEE12L3/4UNFOMD	315	315
	15	3/4-16 UNF-2A	12	10.0	29.3	28	21	28	13	36	22	22	27	164	TEE15L3/4UNFOMD	315	315
	15	7/8-14 UNF-2A	12	12.5	29.3	28	21	28	15	36	22	27	27	182	TEE15L7/8UNFOMD	315	315
	18	7/8-14 UNF-2A	15	12.5	29.3	31	24	32	15	40	27	27	32	265	TEE18L7/8UNFOMD	315	315
	18	1 1/16-12 UN-2A	15	15.5	29.3	31	24	32	17	40	30	32	32	348	TEE18L11/16UNOMD	315	315
	22	1 1/16-12 UN-2A	19	15.5	36.7	35	28	35	17	44	30	32	36	354	TEE22L11/16UNOMD	160	160
	28	1 5/16-12 UN-2A	24	21.5	44.0	38	31	42	17	47	36	41	41	625	TEE28L15/16UNOMD	160	160
	35	1 5/8-12 UN-2A	30	27.5	55.0	48	38	46	17	59	50	50	50	1245	TEE35L15/8UNOMD	160	160
	42	1 7/8-12 UN-2A	36	33.5	55.0	49	38	47	17	61	50	55	60	1538	TEE42L17/8UNOMD	160	160
	S ⁴⁾	06	7/16-20 UNF-2A	4	4.5	16.5	22	15	20	12	30	14	14	17	69	TEE06S7/16UNFOMD	400
08		9/16-18 UNF-2A	5	7.5	18.3	24	17	25	12	32	19	17	19	116	TEE08S9/16UNFOMD	400	400
10		9/16-18 UNF-2A	7	7.5	20.2	25	18	26	12	34	19	17	22	120	TEE10S9/16UNFOMD	400	400
12		3/4-16 UNF-2A	8	10.0	25.7	29	22	30	14	38	22	22	24	195	TEE12S3/4UNFOMD	400	400
16		7/8-14 UNF-2A	12	12.5	29.3	33	25	34	16	43	27	27	30	294	TEE16S7/8UNFOMD	400	400
20		1 1/16-12 UN-2A	16	15.5	36.7	38	28	37	19	49	30	32	36	441	TEE20S11/16UNOMD	400	400
25		1 1/16-12 UN-2A	20	15.5	44.0	42	30	50	19	54	36	32	46	628	TEE25S11/16UNOMD	400	400
30		1 5/8-12 UN-2A	25	27.5	55.0	49	36	50	19	62	50	50	50	1276	TEE30S15/8UNOMD	250	250
38		1 7/8-12 UN-2A	32	33.5	55.0	50	34	51	19	65	50	55	60	1256	TEE38S17/8UNOMD	250	250

1) Pressure shown = item deliverable

3) L = light series; 4) S = heavy series

$$\frac{PN \text{ (bar)}}{10} = PN \text{ (MPa)}$$

Delivery without nut and ring. Information on ordering complete fittings or alternative sealing materials see page 17.

Order code suffixes			
Material	Suffix surface and material	Example	Standard sealing material (no additional suffix needed)
Steel, zinc plated, chrome ⁶ -free	CF	TEE16S7/8UNFOMDCF	NBR
Steel, zinc yellow plated	A3C	TEE16S7/8UNFOMDA3C	NBR

*Please add the **suffixes** below according to the material/surface required.

LEE-OR Adjustable locknut run tee

EO 24° cone end / Adjustable metric thread – O-ring (ISO 6149)

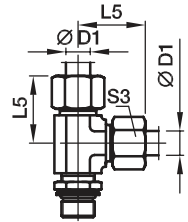
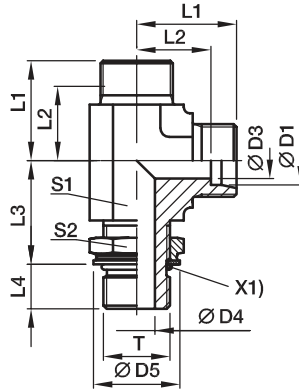

X1) O-ring OR

Series	D1	T	D3	D4	D5	L1	L2	L3	L4	L5	S1	S2	S3	Weight g/1 piece	Order code*	PN (bar) ¹⁾	
																CF	A3C
L ³⁾	06	M10 1	4	4.5	15	21	14	20	7	29	14	14	14	52	LEE06LMOROMD	315	315
	08	M12 1.5	6	6.0	18	23	16	22	10	31	14	17	17	64	LEE08LMOROMD	315	315
	10	M14 1.5	8	7.5	20	24	17	25	10	32	19	19	19	100	LEE10LMOROMD	315	315
	12	M16 1.5	10	9.0	23	26	19	26	10	34	19	22	22	111	LEE12LMOROMD	315	315
	15	M18 1.5	12	11.0	25	28	21	30	11	36	22	24	27	166	LEE15LMOROMD	315	315
	18	M22 1.5	15	14.0	28	31	24	33	12	40	27	27	32	251	LEE18LMOROMD	315	315
	22	M27 2	19	18.0	33	35	28	25	14	44	30	32	36	334	LEE22LM27X2OROMD	160	160
	28	M33 2	24	23.0	41	38	31	38	14	47	36	41	41	458	LEE28LMOROMD	160	160
	35	M42 2	30	30.0	51	48	38	48	14	59	50	50	50	1127	LEE35LMOROMD	160	160
	42	M48 2	36	36.0	56	49	38	49	16	61	50	55	60	941	LEE42LMOROMD	160	160
S ⁴⁾	06	M12 1.5	4	4.0	18	22	15	22	10	30	14	17	17	72	LEE06SMOROMD	400	400
	08	M14 1.5	5	6.0	20	24	17	26	10	32	19	19	19	117	LEE08SMOROMD	400	400
	10	M16 1.5	7	7.0	23	25	18	27	11	34	19	22	22	128	LEE10SMOROMD	400	400
	12	M18 1.5	8	9.0	25	29	22	31	12	38	22	24	24	184	LEE12SMOROMD	400	400
	16	M22 1.5	12	12.0	28	33	25	35	14	43	27	27	30	300	LEE16SMOROMD	400	400
	20	M27 2	16	15.0	33	38	28	35	16	49	30	32	36	433	LEE20SMOROMD	400	400
	25	M33 2	20	20.0	41	42	30	44	16	54	36	41	46	644	LEE25SMOROMD	315	315
	30	M42 2	25	26.0	51	49	36	51	17	62	50	50	50	1347	LEE30SMOROMD	250	250
	38	M48 2	32	32.0	56	50	34	54	19	65	50	55	60	1317	LEE38SMOROMD	200	200

¹⁾ Pressure shown = item deliverable

³⁾ L = light series; ⁴⁾ S = heavy series

$$\frac{PN(\text{bar})}{10} = PN(\text{MPa})$$

Delivery without nut and ring. Information on ordering complete fittings or alternative sealing materials see page 17.

*Please add the **suffixes** below according to the material/surface required.

Order code suffixes			
Material	Suffix surface and material	Example	Standard sealing material (no additional suffix needed)
Steel, zinc plated, chrome ⁶ -free	CF	LEE16SMOROMDCF	NBR
Steel, zinc yellow plated	A3C	LEE16SMOROMDA3C	NBR

LEE-M Adjustable locknut run tee

EO 24° cone end / Adjustable metric thread – O-ring + retaining ring

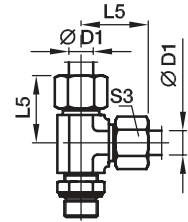
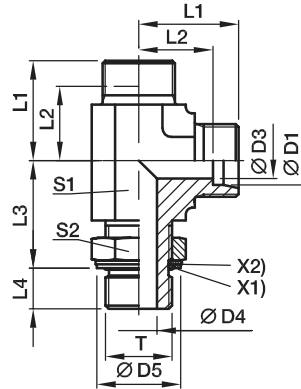

X1) O-ring OR
X2) retaining ring

Series	D1	T	D3	D4	D5	L1	L2	L3	L4	L5	S1	S2	S3	Weight g/1 piece	Order code*	PN (bar) ¹⁾		
																CF	A3C	71
L ³⁾	06	M10 1	4	4.5	15	21	14	20	7	29	14	14	14	52	LEE06LMOMD	315	315	315
	08	M12 1.5	6	6.0	18	23	16	22	10	31	14	17	17	65	LEE08LMOMD	315	315	315
	10	M14 1.5	8	7.5	20	24	17	25	9	32	19	19	19	98	LEE10LMOMD	315	315	315
	12	M16 1.5	10	9.0	23	26	19	26	9	34	19	22	22	107	LEE12LMOMD	315	315	315
	15	M18 1.5	12	11.0	25	28	21	30	11	36	22	24	27	165	LEE15LMOMD	315	315	315
	18	M22 1.5	15	14.0	28	31	24	33	11	40	27	27	32	254	LEE18LMOMD	250	250	250
	22	M27 2	19	18.0	33	35	28	35	14	44	30	32	36	338	LEE22LM27X20MD	160	160	160
	28	M33 2	24	23.0	41	38	31	38	14	47	36	41	41	454	LEE28LMOMD	160	160	160
	35	M42 2	30	30.0	51	48	38	48	14	59	50	50	50	1139	LEE35LMOMD	160	160	160
	42	M48 2	36	36.0	56	49	38	49	16	61	50	55	60	1011	LEE42LMOMD	160	160	160
S ⁴⁾	06	M12 1.5	4	4.0	18	22	15	22	10	30	14	17	17	72	LEE06SMOMD	315	315	315
	08	M14 1.5	5	6.0	20	24	17	26	10	32	19	19	19	114	LEE08SMOMD	315	315	315
	10	M16 1.5	7	7.0	23	25	18	27	11	34	19	22	22	122	LEE10SMOMD	315	315	315
	12	M18 1.5	8	9.0	25	29	22	31	12	38	22	24	24	176	LEE12SMOMD	315	315	315
	16	M22 1.5	12	12.0	28	33	25	35	14	43	27	27	30	297	LEE16SMOMD	250	250	250
	20	M27 2	16	15.0	33	38	28	39	16	49	30	32	36	428	LEE20SMOMD	250	250	250
	25	M33 2	20	20.0	41	42	30	44	16	54	36	41	46	621	LEE25SMOMD	160	160	160
	30	M42 2	25	26.0	51	49	36	51	17	62	50	50	50	1335	LEE30SMOMD	160	160	160
	38	M48 2	32	32.0	56	50	34	54	19	65	50	55	60	1293	LEE38SMOMD	160	160	160

¹⁾ Pressure shown = item deliverable

³⁾ L = light series; ⁴⁾ S = heavy series

$$\frac{\text{PN (bar)}}{10} = \text{PN (MPa)}$$

Delivery without nut and ring. Information on ordering complete fittings or alternative sealing materials see page 17.

*Please add the **suffixes** below according to the material/surface required.

Order code suffixes			
Material	Suffix surface and material	Example	Standard sealing material (no additional suffix needed)
Steel, zinc plated, chrome ³⁾ -free	CF	LEE16SMOMDCF	NBR
Steel, zinc yellow plated	A3C	LEE16SMOMDA3C	NBR
Stainless Steel	71	LEE16SMOMD71	VIT

LEE-R Adjustable locknut run tee

EO 24° cone end / Adjustable BSPP thread – O-ring + retaining ring (ISO 1179)
 for ports with small or wide spot face;
 differences in D5 in Stainless Steel are only for ports with wide spot face
 (e. g. LEE16SRBOMD71)

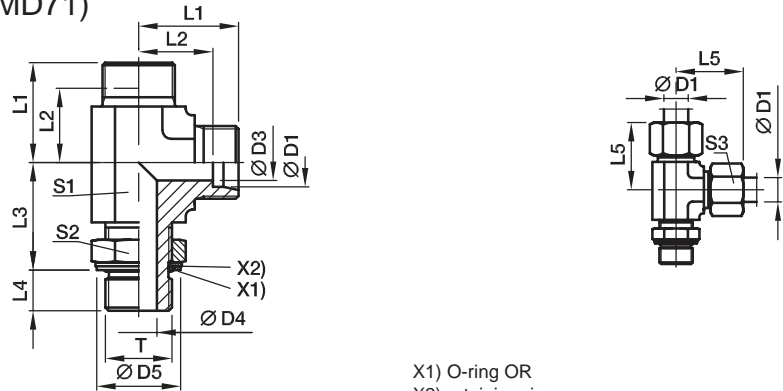

X1) O-ring OR
 X2) retaining ring

Series	D1	T	D3	D4	D5 ⁵⁾	D5 ⁶⁾	L1	L2	L3	L4	L5	S1	S2	S3	Weight g/1 piece	Order code*	PN (bar) ¹⁾		
																	CF	A3C	71
L ³⁾	06	G 1/8A	4	4.5	15	15.0	21	14	19	7	29	14	14	14	53	LEE06LROMD	315	315	315
	08	G 1/4A	6	7.5	20	20.0	23	16	23	9	31	14	19	17	68	LEE08LROMD	315	315	315
	10	G 1/4A	8	7.5	20	20.0	24	17	25	9	32	19	19	19	98	LEE10LROMD	315	315	315
	12	G 3/8A	10	10.0	23	23.5	26	19	28	9	34	19	22	22	114	LEE12LROMD	250	250	250
	15	G 1/2A	12	12.5	28	28.5	28	21	30	13	36	22	27	27	183	LEE15LROMD	250	250	250
	18	G 1/2A	15	12.5	28	28.5	31	24	36	13	40	27	27	32	271	LEE18LROMD	250	250	250
	22	G 3/4A	19	15.5	33	34.5	35	28	36	13	44	30	36	36	367	LEE22LROMD	160	160	160
	28	G 1A	24	21.5	41	43.5	38	31	44	15	47	36	41	41	525	LEE28LROMD	160	160	160
	35	G 1 1/4A	30	27.5	51	52.5	48	38	50	15	59	50	50	50	1194	LEE35LROMD	160	160	160
	42	G 1 1/2A	36	33.0	56	60.0	49	38	52	15	61	50	55	60	1090	LEE42LROMD	160	160	160
S ⁴⁾	06	G 1/4A	4	7.5	20	20.0	22	15	23	9	30	14	19	17	71	LEE06SROMD	315	315	315
	08	G 1/4A	5	7.5	20	20.0	24	17	27	9	32	19	19	19	113	LEE08SROMD	315	315	315
	10	G 3/8A	7	10.0	23	23.5	25	18	29	9	34	19	22	22	124	LEE10SROMD	250	250	250
	12	G 3/8A	8	10.0	23	23.5	29	22	29	9	38	22	22	24	167	LEE12SROMD	250	250	250
	16	G 1/2A	12	12.5	28	28.5	33	25	36	13	43	27	27	30	295	LEE16SROMD	250	250	250
	20	G 3/4A	16	15.5	33	34.5	38	28	39	12	49	30	36	36	440	LEE20SROMD	250	250	250
	25	G 1A	20	21.5	41	43.5	42	30	44	14	54	36	41	46	629	LEE25SROMD	250	250	250
	30	G 1 1/4A	25	27.5	51	52.5	49	36	49	15	62	50	50	50	1285	LEE30SROMD	160	160	160
	38	G 1 1/2A	32	33.0	56	60.0	50	34	55	15	65	50	55	60	1272	LEE38SROMD	160	160	160

1) Pressure shown = item deliverable

3) L = light series; 4) S = heavy series

$$\frac{\text{PN (bar)}}{10} = \text{PN (MPa)}$$

Delivery without nut and ring. Information on ordering complete fittings or alternative sealing materials see page I7.

5) Steel; 6) Stainless Steel

*Please add the **suffixes** below according to the material/surface required.

Order code suffixes			
Material	Suffix surface and material	Example	Standard sealing material (no additional suffix needed)
Steel, zinc plated, chrome ⁶⁾ -free	CF	LEE16SROMDCF	NBR
Steel, zinc yellow plated	A3C	LEE16SROMDA3C	NBR
Stainless Steel	71	LEE16SRBOMD71	VIT

LEE-UNF Adjustable locknut run tee

EO 24° cone end / Adjustable UN/UNF thread – O-Ring (ISO 11926)

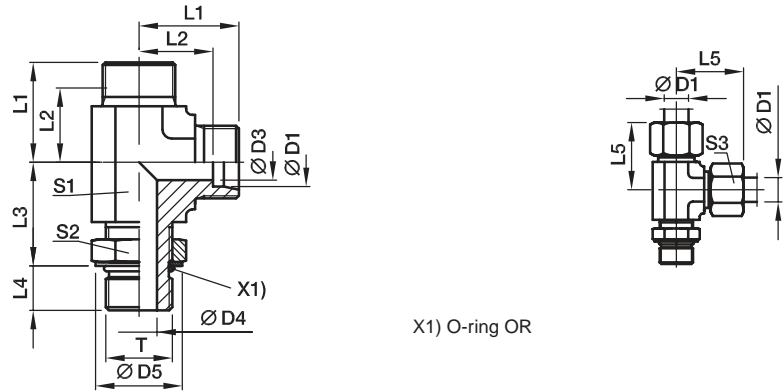

Series	D1	T	D3	D4	D5	L1	L2	L3	L4	L5	S1	S2	S3	Weight g/1 piece	Order code*	PN (bar) ¹⁾	
																CF	A3C
L ³⁾	06	7/16-20 UNF-2A	4	4.5	16.5	21	14	19	10	29	14	14	14	57	LEE06L7/16UNFOMD	315	315
	08	7/16-20 UNF-2A	6	4.5	18.3	23	16	19	10	31	14	14	17	61	LEE08L7/16UNFOMD	315	315
	10	9/16-18 UNF-2A	8	7.5	20.2	24	17	24	10	32	19	17	19	101	LEE10L9/16UNFOMD	315	315
	12	9/16-18 UNF-2A	10	7.5	25.7	26	19	25	11	34	19	17	22	106	LEE12L9/16UNFOMD	315	315
	12	3/4-16 UNF-2A	10	10.0	25.7	26	19	25	13	34	19	22	22	122	LEE12L3/4UNFOMD	315	315
	15	3/4-16 UNF-2A	12	10.0	29.3	28	21	28	13	36	22	22	27	166	LEE15L3/4UNFOMD	315	315
	15	7/8-14 UNF-2A	12	12.5	29.3	28	21	28	15	36	22	27	27	183	LEE15L7/8UNFOMD	315	315
	18	7/8-14 UNF-2A	15	12.5	29.3	31	24	32	15	40	27	27	32	263	LEE18L7/8UNFOMD	315	315
	18	1 1/16-12 UN-2A	15	15.5	29.3	31	24	32	17	40	30	32	32	335	LEE18L11/16UNOMD	315	315
	22	1 1/16-12 UN-2A	19	15.5	36.7	35	28	35	17	44	30	32	36	355	LEE22L11/16UNOMD	160	160
	28	1 5/16-12 UN-2A	24	21.5	44.0	38	31	42	17	47	36	41	41	625	LEE28L15/16UNOMD	160	160
	35	1 5/8-12 UN-2A	30	27.5	55.0	48	38	46	17	59	50	50	50	1245	LEE35L15/8UNOMD	160	160
	42	1 7/8-12 UN-2A	36	33.5	55.0	49	38	47	17	61	50	55	60	1538	LEE42L17/8UNOMD	160	160
	S ⁴⁾	06	7/16-20 UNF-2A	4	4.5	16.5	22	15	20	12	30	14	14	17	66	LEE06S7/16UNFOMD	400
08		9/16-18 UNF-2A	5	7.5	18.3	24	17	25	12	32	19	17	19	114	LEE08S9/16UNFOMD	400	400
10		9/16-18 UNF-2A	7	7.5	20.2	25	18	26	12	34	19	17	22	118	LEE10S9/16UNFOMD	400	400
12		3/4-16 UNF-2A	8	10.0	25.7	29	22	30	14	38	22	22	24	185	LEE12S3/4UNFOMD	400	400
16		7/8-14 UNF-2A	12	12.5	29.3	33	25	34	16	43	27	27	30	291	LEE16S7/8UNFOMD	400	400
20		1 1/16-12 UN-2A	16	15.5	36.7	38	28	37	19	49	30	32	36	453	LEE20S11/16UNOMD	400	400
25		1 1/16-12 UN-2A	20	15.5	44.0	42	30	50	19	54	36	32	46	589	LEE25S11/16UNOMD	400	400
30		1 5/8-12 UN-2A	25	27.5	55.0	49	36	50	19	62	50	50	50	1276	LEE30S15/8UNOMD	250	250
38		1 7/8-12 UN-2A	32	33.5	55.0	50	34	51	19	65	50	55	60	1256	LEE38S17/8 UNOMD	250	250

1) Pressure shown = item deliverable

3) L = light series; 4) S = heavy series

$$\frac{\text{PN (bar)}}{10} = \text{PN (MPa)}$$

Delivery without nut and ring. Information on ordering complete fittings or alternative sealing materials see page I7.

*Please add the **suffixes** below according to the material/surface required.

Order code suffixes			
Material	Suffix surface and material	Example	Standard sealing material (no additional suffix needed)
Steel, zinc plated, chrome ⁶ -free	CF	LEE16S7/8UNFOMDCF	NBR
Steel, zinc yellow plated	A3C	LEE16S7/8UNFOMDA3C	NBR

VEE-OR Adjustable locknut 45° elbow

EO 24° cone end / Adjustable metric thread – O-ring (ISO 6149)

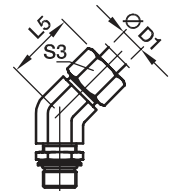
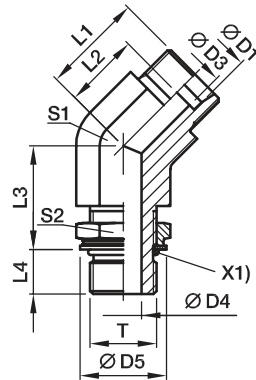

X1) O-ring OR

Series	D1	T	D3	D4	D5	L1	L2	L3	L4	L5	S1	S2	S3	Weight g/1 piece	Order code*	PN (bar) ¹⁾	
																CF	A3C
L ³⁾	06	M10 1	4	4.5	15	16	14	20	7	29	14	14	14	45	VEE06LMOROMD	315	315
	08	M12 1.5	6	6.0	18	19	16	22	10	31	14	17	17	42	VEE08LMOROMD	315	315
	10	M14 1.5	8	7.5	20	19	17	25	10	32	19	19	19	73	VEE10LMOROMD	315	315
	12	M16 1.5	10	9.0	23	21	19	26	10	34	19	22	22	81	VEE12LMOROMD	315	315
	15	M18 1.5	12	11.0	25	24	21	30	11	36	22	24	27	122	VEE15LMOROMD	315	315
	18	M22 1.5	15	14.0	28	24	24	33	12	40	27	27	32	178	VEE18LMOROMD	315	315
	22	M27 2	19	18.0	33	26	28	35	14	44	30	32	36	217	VEE22LM27X20ROMD	160	160
	28	M33 2	24	23.0	41	31	31	38	14	47	36	41	41	364	VEE28LMOROMD	160	160
	35	M42 2	30	30.0	51	37	38	48	14	59	50	50	50	728	VEE35LMOROMD	160	160
	42	M48 2	36	36.0	56	37	38	49	16	61	50	55	60	690	VEE42LMOROMD	160	160
S ⁴⁾	06	M12 1.5	4	4.0	18	16	15	22	10	30	14	17	17	44	VEE06SMOROMD	400	400
	08	M14 1.5	5	6.0	20	19	17	26	10	32	19	19	19	72	VEE08SMOROMD	400	400
	10	M16 1.5	7	7.0	23	21	18	27	11	34	19	22	22	93	VEE10SMOROMD	400	400
	12	M18 1.5	8	9.0	25	24	22	31	12	38	22	24	24	130	VEE12SMOROMD	400	400
	16	M22 1.5	12	12.0	28	24	25	35	14	43	27	27	30	196	VEE16SMOROMD	400	400
	20	M27 2	16	15.0	33	27	28	39	16	49	30	32	36	290	VEE20SMOROMD	400	400
	25	M33 2	20	20.0	41	31	30	44	16	54	36	41	46	446	VEE25SMOROMD	315	315
	30	M42 2	25	26.0	51	37	36	51	17	62	50	50	50	811	VEE30SMOROMD	250	250
	38	M48 2	32	32.0	56	37	34	54	19	65	50	55	60	850	VEE38SMOROMD	200	200

¹⁾ Pressure shown = item deliverable

³⁾ L = light series; ⁴⁾ S = heavy series

$$\frac{\text{PN (bar)}}{10} = \text{PN (MPa)}$$

Delivery without nut and ring. Information on ordering complete fittings or alternative sealing materials see page 17.

*Please add the **suffixes** below according to the material/surface required.

Order code suffixes			
Material	Suffix surface and material	Example	Standard sealing material (no additional suffix needed)
Steel, zinc plated, chrome ⁶ -free	CF	VEE16SMOROMDCF	NBR
Steel, zinc yellow plated	A3C	VEE16SMOROMDA3C	NBR

VEE-M Adjustable locknut 45° elbow

EO 24° cone end / Adjustable metric thread – O-ring + retaining ring

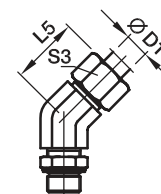
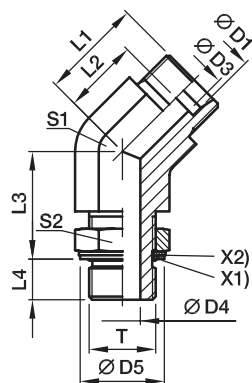

X1) O-ring OR
X2) retaining ring

Series	D1	T	D3	D4	D5	L1	L2	L3	L4	L5	S1	S2	S3	Weight g/1 piece	Order code*	PN (bar) ¹⁾		
																CF	A3C	71
L ³⁾	06	M10 1	4	4.5	15	16	9	21	7	24	14	14	14	39	VEE06LMOMD	315	315	315
	08	M12 1.5	6	6.0	18	19	12	19	10	27	14	17	17	49	VEE08LMOMD	315	315	315
	10	M14 1.5	8	7.5	20	19	12	19	12	24	9	27	19	71	VEE10LMOMD	315	315	315
	12	M16 1.5	10	9.0	23	21	14	25	9	28	19	22	22	78	VEE12LMOMD	315	315	315
	15	M18 1.5	12	11.0	25	24	17	24	11	32	22	24	27	121	VEE15LMOMD	315	315	315
	18	M22 1.5	15	14.0	28	24	17	31	11	33	27	27	32	180	VEE18LMOMD	250	250	250
	22	M27 2	19	18.0	33	26	19	31	14	35	30	32	36	221	VEE22LM27X20MD	160	160	160
	28	M33 2	24	23.0	41	31	23	35	14	40	36	41	41	360	VEE28LMOMD	160	160	160
	35	M42 2	30	30.0	51	37	27	37	14	48	50	50	50	741	VEE35LMOMD	160	160	160
	42	M48 2	36	36.0	56	37	26	37	16	49	50	55	60	688	VEE42LMOMD	160	160	160
S ⁴⁾	06	M12 1.5	4	4.0	18	16	9	19	10	24	14	17	17	44	VEE06SMOMD	315	315	315
	08	M14 1.5	5	6.0	20	19	12	19	10	27	19	19	19	69	VEE08SMOMD	315	315	315
	10	M16 1.5	7	7.0	23	21	13	23	11	29	19	22	22	86	VEE10SMOMD	315	315	315
	12	M18 1.5	8	9.0	25	24	17	25	12	33	22	24	24	123	VEE12SMOMD	315	315	315
	16	M22 1.5	12	12.0	28	24	16	30	14	34	27	27	30	192	VEE16SMOMD	250	250	250
	20	M27 2	16	15.0	33	27	16	35	16	38	30	32	36	285	VEE20SMOMD	250	250	250
	25	M33 2	20	20.0	41	31	19	37	16	43	36	41	46	425	VEE25SMOMD	160	160	160
	30	M42 2	25	26.0	51	37	24	37	17	50	50	50	50	799	VEE30SMOMD	160	160	160
	38	M48 2	32	32.0	56	37	21	38	19	52	50	55	60	825	VEE38SMOMD	160	160	160

¹⁾ Pressure shown = item deliverable

³⁾ L = light series; ⁴⁾ S = heavy series

$$\frac{\text{PN (bar)}}{10} = \text{PN (MPa)}$$

Delivery without nut and ring. Information on ordering complete fittings or alternative sealing materials see page 17.

*Please add the **suffixes** below according to the material/surface required.

Order code suffixes			
Material	Suffix surface and material	Example	Standard sealing material (no additional suffix needed)
Steel, zinc plated, chrome ³⁾ -free	CF	VEE16SMOMDCF	NBR
Steel, zinc yellow plated	A3C	VEE16SMOMDA3C	NBR
Stainless Steel	71	VEE16SMOMD71	VIT

VEE-R Adjustable locknut 45° elbow

EO 24° cone end / Adjustable BSPB thread – O-ring + retaining ring (ISO 1179)
 for ports with small or wide spot face;
 differences in D5 in Stainless Steel are only for ports with wide spot face
 (e. g. VEE16SRBOMD71)

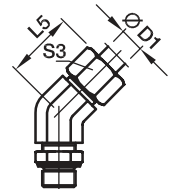
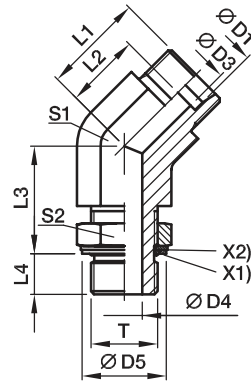

X1) O-ring OR
 X2) retaining ring

Series	D1	T	D3	D4	D5 ⁵⁾	D5 ⁶⁾	L1	L2	L3	L4	L5	S1	S2	S3	Weight g/1 piece	Order code*	PN (bar) ¹⁾		
																	CF	A3C	71
L ³⁾	06	G 1/8A	4	4.5	15	15.0	16	9	21	7	24	14	14	14	39	VEE06LROMD	315	315	315
	08	G 1/4A	6	7.5	20	20.0	19	12	20	9	27	14	19	17	46	VEE08LROMD	315	315	315
	10	G 1/4A	8	7.5	20	20.0	19	12	25	9	27	19	19	19	74	VEE10LROMD	315	315	315
	12	G 3/8A	10	10.0	23	23.5	21	14	28	9	28	19	22	22	85	VEE12LROMD	250	250	250
	15	G 1/2A	12	12.5	28	28.5	24	17	26	13	32	22	27	27	134	VEE15LROMD	250	250	250
	18	G 1/2A	15	12.5	28	28.5	24	17	32	13	33	27	27	32	189	VEE18LROMD	250	250	250
	22	G 3/4A	19	15.5	33	34.5	26	19	37	13	35	30	36	36	283	VEE22LROMD	160	160	160
	28	G 1A	24	21.5	41	43.5	31	23	37	15	40	36	41	41	410	VEE28LROMD	160	160	160
	35	G 1 1/4A	30	27.5	51	52.5	37	27	39	15	48	50	50	50	807	VEE35LROMD	160	160	160
	42	G 1 1/2A	36	33.0	56	60.0	37	26	39	15	49	50	55	60	762	VEE42LROMD	160	160	160
S ⁴⁾	06	G 1/4A	4	7.5	20	20.0	16	9	19	9	24	14	19	17	45	VEE06SROMD	315	315	315
	08	G 1/4A	5	7.5	20	20.0	19	12	23	9	27	19	19	19	76	VEE08SROMD	315	315	315
	10	G 3/8A	7	10.0	23	23.5	21	13	25	9	29	19	22	22	86	VEE10SROMD	250	250	250
	12	G 3/8A	8	10.0	23	23.5	24	17	25	9	33	22	22	24	115	VEE12SROMD	250	250	250
	16	G 1/2A	12	12.5	28	28.5	24	16	31	13	34	27	27	30	186	VEE16SROMD	250	250	250
	20	G 3/4A	16	15.5	33	34.5	27	16	34	12	38	30	36	36	286	VEE20SROMD	250	250	250
	25	G 1A	20	21.5	41	43.5	31	19	37	14	43	36	41	46	425	VEE25SROMD	250	250	250
	30	G 1 1/4A	25	27.5	51	52.5	37	24	38	15	50	50	50	50	793	VEE30SROMD	160	160	160
	38	G 1 1/2A	32	33.0	56	60.0	37	21	38	15	52	50	55	60	791	VEE38SROMD	160	160	160

1) Pressure shown = item deliverable

3) L = light series; 4) S = heavy series

$$\frac{\text{PN (bar)}}{10} = \text{PN (MPa)}$$

Delivery without nut and ring. Information on ordering complete fittings or alternative sealing materials see page I7.

5) Steel; 6) Stainless Steel

*Please add the suffixes below according to the material/surface required.

Order code suffixes			
Material	Suffix surface and material	Example	Standard sealing material (no additional suffix needed)
Steel, zinc plated, chrome ⁵⁾ -free	CF	VEE16SROMDCF	NBR
Steel, zinc yellow plated	A3C	VEE16SROMDA3C	NBR
Stainless Steel	71	VEE16SRBOMD71	VIT

VEE-UNF Adjustable Locknut 45° elbow

EO 24° cone end / Adjustable UN/UNF thread – O-ring (ISO 11926)

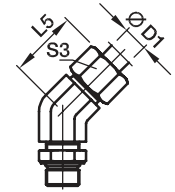
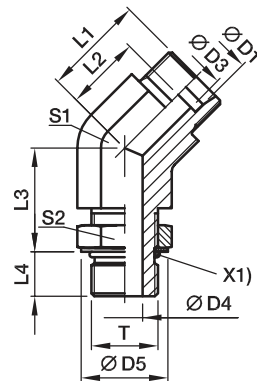

X1) O-ring OR

Series	D1	T	D3	D4	D5	L1	L2	L3	L4	L5	S1	S2	S3	Weight g/1 piece	Order code*	PN (bar) ¹⁾	
																CF	A3C
L ³⁾	06	7/16-20 UNF-2A	4	4.5	16.5	16	9	19	10	24	14	14	14	36	VEE06L7/16UNFOMD	315	315
	08	7/16-20 UNF-2A	6	4.5	18.3	19	12	19	10	27	14	14	17	39	VEE08L7/16UNFOMD	315	315
	10	9/16-18 UNF-2A	8	7.5	20.2	19	12	24	10	27	19	17	19	58	VEE10L7/16UNFOMD	315	315
	12	9/16-18 UNF-2A	10	7.5	25.7	21	14	24	11	28	19	17	22	73	VEE12L9/16UNFOMD	315	315
	12	3/4-16 UNF-2A	10	10.0	25.7	21	14	24	13	28	19	22	22	91	VEE12L3/4UNFOMD	315	315
	15	3/4-16 UNF-2A	12	10.0	29.3	24	17	24	13	32	22	22	27	120	VEE15L3/4UNFOMD	315	315
	15	7/8-14 UNF-2A	12	12.5	29.3	24	17	24	15	32	22	27	27	140	VEE15L7/8UNFOMD	315	315
	18	7/8-14 UNF-2A	15	12.5	29.3	24	17	30	15	33	27	27	32	190	VEE18L7/8UNFOMD	315	315
	18	1 1/16-12 UN-2A	15	15.5	29.3	24	17	30	17	33	30	32	32	205	VEE18L11/16UNOMD	315	315
	22	1 1/16-12 UN-2A	19	15.5	36.7	26	19	33	17	35	30	32	36	274	VEE22L11/16UNOMD	160	160
	28	1 5/16-12 UN-2A	24	21.5	44.0	31	23	35	17	39	36	41	41	402	VEE28L15/16UNOMD	160	160
	35	1 5/8-12 UN-2A	30	27.5	55.0	37	27	37	17	48	50	50	50	794	VEE35L15/8UNOMD	160	160
42	1 7/8-12 UN-2A	36	33.5	55.0	37	26	37	17	49	50	55	60	751	VEE42L17/8UNOMD	160	160	
S ⁴⁾	06	7/16-20 UNF-2A	4	4.5	16.5	16	9	18	12	24	14	14	17	38	VEE06S7/16UNFOMD	400	400
	08	9/16-18 UNF-2A	5	7.5	18.3	19	12	21	12	27	19	17	19	78	VEE08S9/16UNFOMD	400	400
	10	9/16-18 UNF-2A	7	7.5	20.2	21	13	21	12	29	19	17	22	70	VEE10S9/16UNFOMD	400	400
	12	3/4-16 UNF-2A	8	10.0	25.7	24	17	22	14	33	22	22	24	124	VEE12S3/4UNFOMD	400	400
	16	7/8-14 UNF-2A	12	12.5	29.3	24	16	29	16	34	27	27	30	198	VEE16S7/8UNFOMD	400	400
	20	1 1/16-12 UN-2A	16	15.5	36.7	27	16	31	19	38	30	32	36	315	VEE20S11/16UNOMD	400	400
	25	1 1/16-12 UN-2A	20	15.5	44.0	31	30	33	19	54	36	32	46	385	VEE25S11/16UNOMD	400	400
	30	1 5/8-12 UN-2A	25	27.5	55.0	37	24	35	19	50	50	50	50	815	VEE30S15/8UNOMD	250	250
38	1 7/8-12 UN-2A	32	33.5	55.0	37	21	35	19	52	50	55	60	819	VEE38S17/8UNOMD	250	250	

¹⁾ Pressure shown = item deliverable

³⁾ L = light series; ⁴⁾ S = heavy series

$$\frac{PN \text{ (bar)}}{10} = PN \text{ (MPa)}$$

Delivery without nut and ring. Information on ordering complete fittings or alternative sealing materials see page 17.

*Please add the **suffixes** below according to the material/surface required.

Order code suffixes			
Material	Suffix surface and material	Example	Standard sealing material (no additional suffix needed)
Steel, zinc plated, chrome ⁶ -free	CF	VEE16S7/8UNFOMDCF	NBR
Steel, zinc yellow plated	A3C	VEE16S7/8UNFOMDA3C	NBR

WH-M-KDS High pressure banjo elbow

EO 24° cone end / Male metric thread with soft seal ring

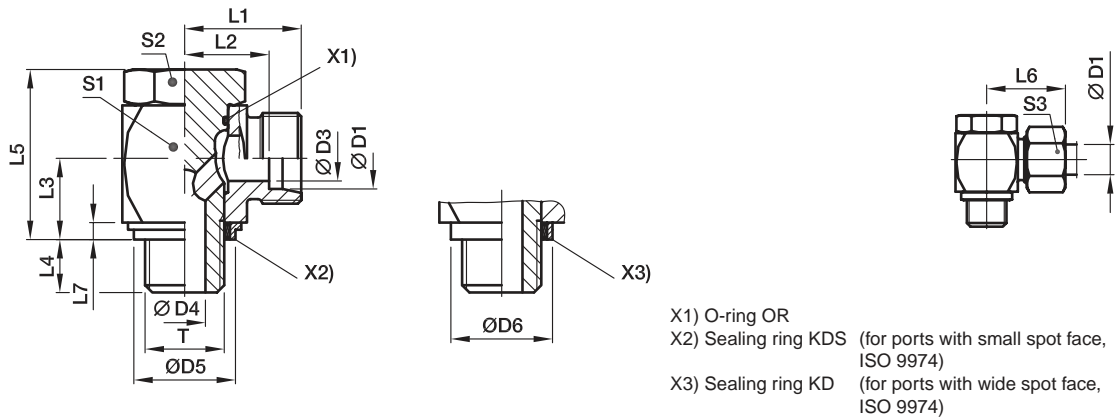

Series	D1	T	D3	D4	D5 KDS	D6 KD	L1	L2	L3	L4	L5	L6	L7	S1	S2	S3	Weight g/1 piece	Order code*	PN (bar) ¹⁾		
																			CF	A3C	71
L ³⁾	06	M10 1	4	4.5	14.9	17.0	19.0	12.0	10.5	8	24.0	27	2.5	17	17	14	54	WH06LMKDSOMD	315	315	315
	08	M12 1.5	6	6.0	17.0	22.0	21.5	14.5	14.0	12	30.0	29	3.0	22	19	17	97	WH08LMKDSOMD	315	315	315
	10	M14 1.5	8	6.0	18.9	22.5	22.5	15.5	14.0	12	30.0	30	3.0	22	19	19	104	WH10LMKDSOMD	315	315	315
	12	M16 1.5	10	7.5	21.9	27.0	25.0	18.0	16.5	12	36.0	33	3.0	27	24	22	180	WH12LMKDSOMD	315	315	315
	15	M18 1.5	11	9.0	23.9	29.0	27.5	21.5	18.5	12	39.5	37	3.0	30	30	27	244	WH15LMKDSOMD	315	315	315
	18	M22 1.5	15	12.0	26.9	32.0	28.5	21.0	21.5	14	45.0	37	4.5	32	30	32	327	WH18LMKDSOMD	315	315	315
	22	M26 1.5	19	17.0	31.9	41.0	35.0	27.5	24.0	16	53.0	44	3.5	41	36	36	573	WH22LMKDSOMD	160	160	160
	28	M33 2	24	21.0	39.9	46.0	39.5	32.0	30.5	18	66.0	49	3.5	50	46	41	1017	WH28LMKDSOMD	160	160	160
	35	M42 2	30	27.0	49.9	57.0	46.5	36.0	35.5	20	76.0	58	3.5	60	55	50	1512	WH35LMKDSOMD	160	160	160
	42	M48 2	36	34.0	55.9	64.0	51.5	40.5	40.5	22	87.0	63	3.5	70	60	60	2217	WH42LMKDSOMD	160	160	160
S ⁴⁾	06	M12 1.5	4	6.0	17.0	22.0	23.5	16.5	14.0	12	30.0	31	3.0	22	19	17	104	WH06SMKDSOMD	400	400	400
	08	M14 1.5	5	6.0	18.9	22.5	23.5	16.5	14.0	12	30.0	31	3.0	22	19	19	110	WH08SMKDSOMD	400	400	400
	10	M16 1.5	7	7.5	21.9	27.0	26.0	18.5	16.5	12	36.0	35	3.0	27	24	22	186	WH10SMKDSOMD	400	400	400
	12	M18 1.5	8	9.0	23.9	29.0	27.5	20.0	18.5	12	39.5	36	3.0	27	27	24	246	WH12SMKDSOMD	400	400	400
	14	M20 1.5	10	10.0		32.0	30.5	22.5	20.0	14	43.5	40	3.0	32	30	27	322	WH14SMKDSOMD			400
	16	M22 1.5	12	12.0	26.9	32.0	30.5	22.0	21.5	14	45.0	40	4.5	32	30	30	327	WH16SMKDSOMD	315	315	315
	20	M27 2	16	16.0	32.9	41.0	37.0	26.5	24.0	16	53.0	48	3.5	41	36	36	598	WH20SMKDSOMD	315	315	315
	25	M33 2	20	21.0	39.9	46.0	43.5	31.5	30.5	18	66.0	56	3.5	50	46	46	1055	WH25SMKDSOMD	250	250	250
	30	M42 2	25	27.0	49.9	57.0	50.5	37.0	35.5	20	76.0	64	3.5	60	55	50	1572	WH30SMKDSOMD	160	160	160
	38	M48 2	32	34.0	55.9	64.0	57.5	41.5	40.5	22	87.0	72	3.5	70	60	60	2317	WH38SMKDSOMD	160	160	160

1) Pressure shown = item deliverable

3) L = light series; 4) S = heavy series

$$\frac{PN \text{ (bar)}}{10} = PN \text{ (MPa)}$$

Delivery without nut and ring. Information on ordering complete fittings or alternative sealing materials see page I7.

*Please add the **suffixes** below according to the material/surface required.

Order code suffixes			
Material	Suffix surface and material	Example	Standard sealing material (no additional suffix needed)
Steel, zinc plated, chrome ² -free	CF	WH16SMKDSOMDCF	NBR
Steel, zinc yellow plated	A3C	WH16SMKDSOMDA3C	NBR
Stainless Steel	71	WH16SMKDSOMD71	VIT/PTFE

Stainless Steel only with sealing ring KD available!
Replace KDS by KD in the order code.

WH-M High pressure banjo elbow

EO 24° cone end / Male metric thread with metal sealing ring

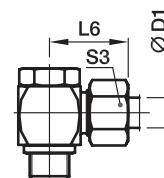
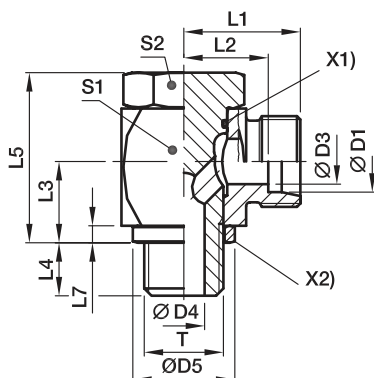

X1) O-ring OR
X2) Sealing ring DKA

Series	D1	T	D3	D4	D5	L1	L2	L3	L4	L5	L6	L7	S1	S2	S3	Weight g/1 piece	Order code*	PN (bar) ¹⁾		
																		CF	A3C	71
L ³⁾	06	M10 1	4	4.5	14	19.0	12.0	10.5	8	24.0	27	2.5	17	17	14	54	WH06LMOMD	250	250	250
	08	M12 1.5	6	6.0	17	21.5	14.5	14.0	12	30.0	29	3.0	22	19	17	97	WH08LMOMD	250	250	250
	10	M14 1.5	8	6.0	19	22.5	15.5	14.0	12	30.0	30	3.0	22	19	19	104	WH10LMOMD	250	250	250
	12	M16 1.5	10	7.5	21	25.0	18.0	16.5	12	36.0	33	3.0	27	24	22	180	WH12LMOMD	250	250	250
	15	M18 1.5	11	9.0	23	27.5	21.5	18.5	12	39.5	37	3.0	30	30	27	243	WH15LMOMD	250	250	250
	18	M22 1.5	15	12.0	27	28.5	21.0	21.5	14	45.0	37	4.5	32	30	32	326	WH18LMOMD	250	250	250
	22	M26 1.5	19	17.0	31	35.0	27.5	24.0	16	53.0	44	3.5	41	36	36	574	WH22LMOMD	160	160	160
	28	M33 2	24	21.0	39	39.5	32.0	30.5	18	66.0	49	3.5	50	46	41	1016	WH28LMOMD	160	160	160
	35	M42 2	30	27.0	49	46.5	36.0	35.5	20	76.0	58	3.5	60	55	50	1512	WH35LMOMD	160	160	160
	42	M48 2	36	34.0	55	51.5	40.5	40.5	22	87.0	63	3.5	70	60	60	2216	WH42LMOMD	160	160	160
S ⁴⁾	06	M12 1.5	4	6.0	17	23.5	16.5	14.0	12	30.0	31	3.0	22	19	17	104	WH06SMOMD	315	315	315
	08	M14 1.5	5	6.0	19	23.5	16.5	14.0	12	30.0	31	3.0	22	19	19	111	WH08SMOMD	315	315	315
	10	M16 1.5	7	7.5	21	26.0	18.5	16.5	12	36.0	35	3.0	27	24	22	186	WH10SMOMD	315	315	315
	12	M18 1.5	8	9.0	23	27.5	20.0	18.5	12	39.5	36	3.0	27	27	24	246	WH12SMOMD	315	315	315
	14	M20 1.5	10	10.0	25	30.5	22.5	20.0	14	43.5	40	3.0	32	30	27	320	WH14SMOMD	315	315	315
	16	M22 1.5	12	12.0	27	30.5	22.0	21.5	14	45.0	40	4.5	32	30	30	326	WH16SMOMD	315	315	315
	20	M27 2	16	16.0	32	37.0	26.5	24.0	16	53.0	48	3.5	41	36	36	596	WH20SMOMD	160	160	160
	25	M33 2	20	21.0	39	43.5	31.5	30.5	18	66.0	56	3.5	50	46	46	1055	WH25SMOMD	160	160	160
	30	M42 2	25	27.0	49	50.5	37.0	35.5	20	76.0	64	3.5	60	55	50	1572	WH30SMOMD	160	160	160
	38	M48 2	32	34.0	55	57.5	41.5	40.5	22	87.0	72	3.5	70	60	60	2316	WH38SMOMD	160	160	160

¹⁾ Pressure shown = item deliverable

³⁾ L = light series; ⁴⁾ S = heavy series

$\frac{PN \text{ (bar)}}{10} = PN \text{ (MPa)}$

Delivery without nut and ring. Information on ordering complete fittings or alternative sealing materials see page 17.

*Please add the **suffixes** below according to the material/surface required.

Order code suffixes			
Material	Suffix surface and material	Example	Standard sealing material (no additional suffix needed)
Steel, zinc plated, chrome ⁶⁾ -free	CF	WH16SMOMDCF	NBR
Steel, zinc yellow plated	A3C	WH16SMOMDA3C	NBR
Stainless Steel	71	WH16SMOMD71	VIT

WH-R-KDS High pressure banjo elbow

EO 24° cone end / Male BSPP thread with soft seal ring

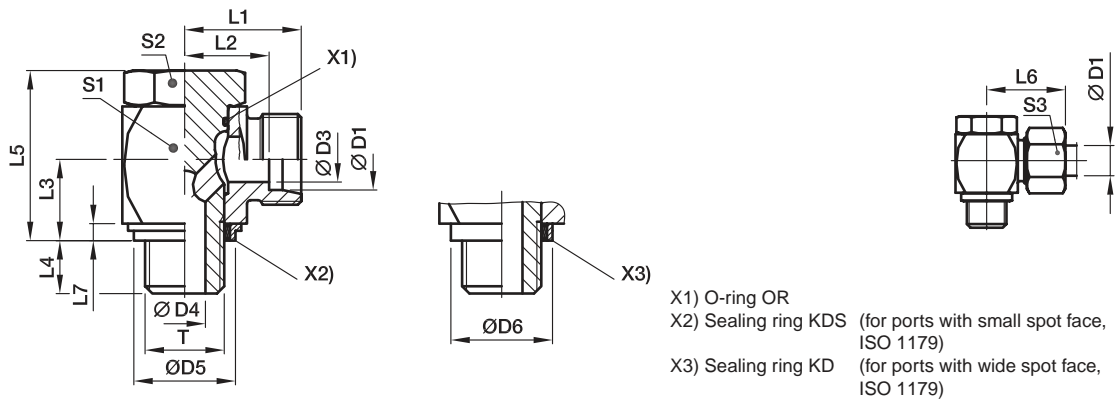

Series	D1	T	D3	D4	D5 KDS	D6 KD	L1	L2	L3	L4	L5	L6	L7	S1	S2	S3	Weight g/1 piece	Order code*	PN (bar) ¹⁾		
																			CF	A3C	71
L ³⁾	06	G 1/8 A	4	4.5	14.9	17	19.0	12.0	10.5	8	24	27	2.5	17	17	14	53	WH06LRKDSOMD	315	315	315
	08	G 1/4 A	6	6.0	18.9	22	21.5	14.5	14.0	12	30	29	3.0	22	19	17	101	WH08LRKDSOMD	315	315	315
	10	G 1/4 A	8	6.0	18.9	22	22.5	15.5	14.0	12	30	30	3.0	22	19	19	102	WH10LRKDSOMD	315	315	315
	12	G 3/8 A	10	7.5	21.9	27	25.0	18.0	16.5	12	36	33	3.0	27	24	22	181	WH12LRKDSOMD	315	315	315
	15	G 1/2 A	12	11.0	26.9	32	28.5	21.5	21.5	14	45	37	4.5	32	30	27	312	WH15LRKDSOMD	315	315	315
	18	G 1/2 A	15	11.0	26.9	32	28.5	21.0	21.5	14	45	37	4.5	32	30	32	319	WH18LRKDSOMD	315	315	315
	22	G 3/4 A	19	17.0	32.9	41	35.0	27.5	24.0	16	53	44	3.5	41	36	36	578	WH22LRKDSOMD	160	160	160
	28	G 1 A	24	21.0	39.9	46	39.5	32.0	30.5	18	66	49	3.5	50	46	41	1035	WH28LRKDSOMD	160	160	160
	35	G 1 1/4 A	30	27.0	49.9	57	46.5	36.0	35.5	20	76	58	3.5	60	55	50	1499	WH35LRKDSOMD	160	160	160
	42	G 1 1/2 A	36	34.0	55.9	64	51.5	40.5	40.5	22	87	63	3.5	70	60	60	2196	WH42LRKDSOMD	160	160	160
S ⁴⁾	06	G 1/4 A	4	6.0	18.9	22	23.5	16.5	14.0	12	30	31	3.0	22	19	17	107	WH06SRKDSOMD	400	400	400
	08	G 1/4 A	5	6.0	18.9	22	23.5	16.5	14.0	12	30	31	3.0	22	19	19	107	WH08SRKDSOMD	400	400	400
	10	G 3/8 A	7	7.5	21.9	27	26.0	18.5	16.5	12	36	35	3.0	27	24	22	188	WH10SRKDSOMD	400	400	400
	12	G 3/8 A	8	7.5	21.9	27	26.0	18.5	16.5	12	36	35	3.0	27	24	24	190	WH12SRKDSOMD	400	400	400
	14	G 1/2 A	10	11.0	26.9	32	30.5	22.5	21.5	15	45	40	4.5	32	30	27	320	WH14SRKDSOMD	400	400	400
	16	G 1/2 A	12	11.0	26.9	32	30.5	22.0	21.5	14	45	40	4.5	32	30	30	324	WH16SRKDSOMD	315	315	315
	20	G 3/4 A	16	17.0	32.9	41	37.0	26.5	24.0	16	53	48	3.5	41	36	36	588	WH20SRKDSOMD	315	315	315
	25	G 1 A	20	21.0	39.9	46	43.5	31.5	30.5	18	66	56	3.5	50	46	46	1073	WH25SRKDSOMD	250	250	250
	30	G 1 1/4 A	25	27.0	49.9	57	50.5	37.0	35.5	20	76	64	3.5	60	55	50	1559	WH30SRKDSOMD	160	160	160
	38	G 1 1/2 A	32	34.0	55.9	64	57.5	41.5	40.5	22	87	72	3.5	70	60	60	2296	WH38SRKDSOMD	160	160	160

¹⁾ Pressure shown = item deliverable

³⁾ L = light series; ⁴⁾ S = heavy series

$$\frac{\text{PN (bar)}}{10} = \text{PN (MPa)}$$

Delivery without nut and ring. Information on ordering complete fittings or alternative sealing materials see page 17.

*Please add the **suffixes** below according to the material/surface required.

Order code suffixes			
Material	Suffix surface and material	Example	Standard sealing material (no additional suffix needed)
Steel, zinc plated, chrome ²⁾ -free	CF	WH16SRKDSOMDCF	NBR
Steel, zinc yellow plated	A3C	WH16SRKDSOMDA3C	NBR
Stainless Steel	71	WH16SRKDOMD71	VIT/PTFE

Stainless Steel only with sealing ring **KD** available!
 Replace KDS by **KD** in the order code.

WH-R High pressure banjo elbow

EO 24° cone end / Male BSPP thread with metal sealing ring

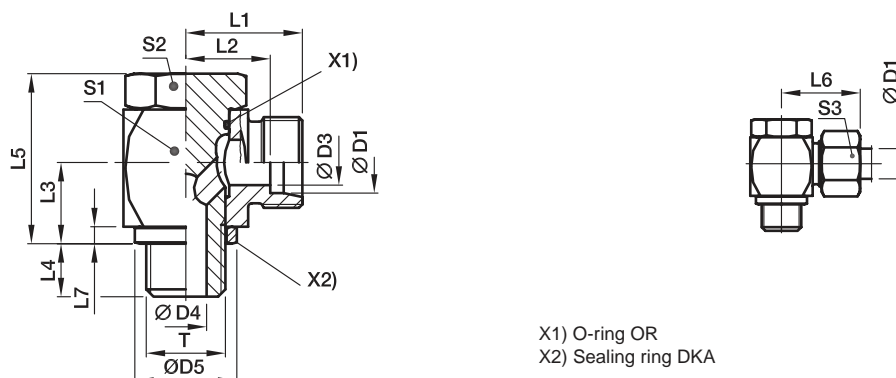

X1) O-ring OR
X2) Sealing ring DKA

Series	D1	T	D3	D4	D5	L1	L2	L3	L4	L5	L6	L7	S1	S2	S3	Weight g/1 piece	Order code*	PN (bar) ¹⁾			
																		CF	A3C	71	MS
L ³⁾	06	G 1/8 A	4	4.5	14	19.0	12.0	10.5	8	24	27	2.5	17	17	14	53	WH06LROMD	250	250	250	160
	08	G 1/4 A	6	6.0	18	21.5	14.5	14.0	12	30	29	3.0	22	19	17	101	WH08LROMD	250	250	250	160
	10	G 1/4 A	8	6.0	18	22.5	15.5	14.0	12	30	30	3.0	22	19	19	102	WH10LROMD	250	250	250	160
	12	G 3/8 A	10	7.5	22	25.0	18.0	16.5	12	36	33	3.0	27	24	22	181	WH12LROMD	250	250	250	160
	15	G 1/2 A	12	11.0	26	28.5	21.5	21.5	14	45	37	4.5	32	30	27	311	WH15LROMD	250	250	250	160
	18	G 1/2 A	15	11.0	26	28.5	21.0	21.5	14	45	37	4.5	32	30	32	319	WH18LROMD	250	250	250	160
	22	G 3/4 A	19	17.0	32	35.0	27.5	24.0	16	53	44	3.5	41	36	36	577	WH22LROMD	160	160	160	
	28	G 1 A	24	21.0	39	39.5	32.0	30.5	18	66	49	3.5	50	46	41	1034	WH28LROMD	160	160	160	
	35	G 1 1/4 A	30	27.0	57	46.5	36.0	35.5	20	76	58	3.5	60	55	50	1500	WH35LROMD	160	160	160	
	42	G 1 1/2 A	36	34.0	55	51.5	40.5	40.5	22	87	63	3.5	70	60	60	2195	WH42LROMD	160	160	160	
S ⁴⁾	06	G 1/4 A	4	6.0	18	23.5	16.5	14.0	12	30	31	3.0	22	19	17	107	WH06SROMD	315	315	315	200
	08	G 1/4 A	5	6.0	18	23.5	16.5	14.0	12	30	31	3.0	22	19	19	107	WH08SROMD	315	315	315	200
	10	G 3/8 A	7	7.5	22	26.0	18.5	16.5	12	36	35	3.0	27	24	22	188	WH10SROMD	315	315	315	200
	12	G 3/8 A	8	7.5	22	26.0	18.5	16.5	12	36	35	3.0	27	24	24	190	WH12SROMD	315	315	315	200
	14	G 1/2 A	10	11.0	26	30.5	22.5	21.5	14	45	40	4.5	32	30	27	320	WH14SROMD	315	315	315	
	16	G 1/2 A	12	11.0	26	30.5	22.0	21.5	14	45	40	4.5	32	30	30	317	WH16SROMD	315	315	315	
	20	G 3/4 A	16	17.0	32	37.0	26.5	24.0	16	53	48	3.5	41	36	36	587	WH20SROMD	160	160	160	
	25	G 1 A	20	21.0	39	43.5	31.5	30.5	18	66	56	3.5	50	46	46	1072	WH25SROMD	160	160	160	
	30	G 1 1/4 A	25	27.0	49	50.5	37.0	35.5	20	76	64	3.5	60	55	50	1560	WH30SROMD	160	160	160	
	38	G 1 1/2 A	32	34.0	55	57.5	41.5	40.5	22	87	72	3.5	70	60	60	2295	WH38SROMD	160	160	160	

¹⁾ Pressure shown = item deliverable

³⁾ L = light series; ⁴⁾ S = heavy series

$$\frac{\text{PN (bar)}}{10} = \text{PN (MPa)}$$

Delivery without nut and ring. Information on ordering complete fittings or alternative sealing materials see page 17.

*Please add the **suffixes** below according to the material/surface required.

Order code suffixes			
Material	Suffix surface and material	Example	Standard sealing material (no additional suffix needed)
Steel, zinc plated, chrome ⁶⁾ -free	CF	WH16SROMDCF	NBR
Steel, zinc yellow plated	A3C	WH16SROMDA3C	NBR
Stainless Steel	71	WH16SROMD71	VIT
Brass	MS	WH18LROMDMS	NBR

TH-M-KDS High pressure banjo tee

EO 24° cone end / Male metric thread with soft seal ring

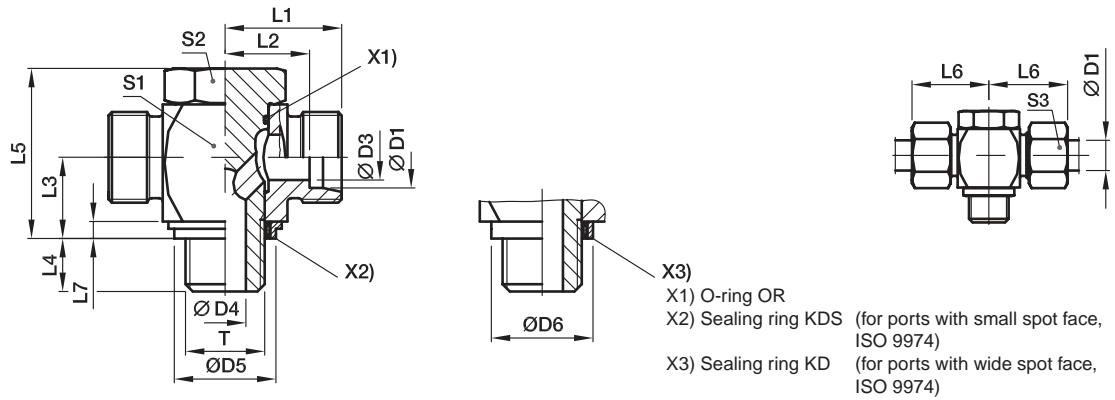

Series	D1	T	D3	D4	D5 KDS	D6 KD	L1	L2	L3	L4	L5	L6	L7	S1	S2	S3	Weight g/1 piece	Order code*	PN (bar) ¹⁾		
																			CF	A3C	71
L ³⁾	06	M10 1	4	4.5	14.9	17.0	19.0	12.0	10.5	8	24.0	27	2.5	17	17	14	59	TH06LMKDSOMD	315	315	315
	08	M12 1.5	6	6.0	17.0	22.0	21.5	14.5	14.0	12	30.0	29	3.0	22	19	17	104	TH08LMKDSOMD	315	315	315
	10	M14 1.5	8	6.0	18.9	22.5	22.5	15.5	14.0	12	30.0	30	3.0	22	19	19	112	TH10LMKDSOMD	315	315	315
	12	M16 1.5	10	7.5	21.9	27.0	25.0	18.0	16.5	12	36.0	33	3.0	27	24	22	192	TH12LMKDSOMD	315	315	315
	15	M18 1.5	11	9.0	23.9	29.0	27.5	21.5	18.5	12	39.5	37	3.0	30	30	27	258	TH15LMKDSOMD	315	315	315
	18	M22 1.5	15	12.0	26.9	32.0	28.5	21.0	21.5	14	45.0	37	4.5	32	30	32	337	TH18LMKDSOMD	315	315	315
	22	M26 1.5	19	17.0	31.9	41.0	35.0	27.5	24.0	16	53.0	44	3.5	41	36	36	589	TH22LMKDSOMD	160	160	160
	28	M33 2	24	21.0	39.9	46.0	39.5	32.0	30.5	18	66.0	49	3.5	50	46	41	1072	TH28LMKDSOMD	160	160	160
	35	M42 2	30	27.0	49.9	57.0	46.5	36.0	35.5	20	76.0	58	3.5	60	55	50	1778	TH35LMKDSOMD	160	160	160
	42	M48 2	36	34.0	55.9	64.0	51.5	40.5	40.5	22	87.0	63	3.5	70	60	60	2566	TH42LMKDSOMD	160	160	160
S ⁴⁾	06	M12 1.5	4	6.0	17.0	22.0	23.5	16.5	14.0	12	30.0	31	3.0	22	19	17	112	TH06SMKDSOMD	400	400	400
	08	M14 1.5	5	6.0	18.9	22.5	23.5	16.5	14.0	12	30.0	31	3.0	22	19	19	123	TH08SMKDSOMD	400	400	400
	10	M16 1.5	7	7.5	21.9	27.0	26.0	18.5	16.5	12	36.0	35	3.0	27	24	22	200	TH10SMKDSOMD	400	400	400
	12	M18 1.5	8	9.0	23.9	29.0	27.5	20.0	18.5	12	39.5	36	3.0	27	27	24	261	TH12SMKDSOMD	400	400	400
	14	M20 1.5	10	10.0		32.0	30.5	22.5	20.0	14	43.5	40	3.0	32	30	27	334	TH14SMKDSOMD			400
	16	M22 1.5	12	12.0	26.9	32.0	30.5	22.0	21.5	14	45.0	40	4.5	32	30	30	351	TH16SMKDSOMD	315	315	315
	20	M27 2	16	16.0	32.9	41.0	37.0	26.5	24.0	16	53.0	48	3.5	41	36	36	629	TH20SMKDSOMD	315	315	315
	25	M33 2	20	21.0	39.9	46.0	43.5	31.5	30.5	18	66.0	56	3.5	50	46	46	1106	TH25SMKDSOMD	250	250	250
	30	M42 2	25	27.0	49.9	57.0	50.5	37.0	35.5	20	76.0	64	3.5	60	55	50	1843	TH30SMKDSOMD	160	160	160
	38	M48 2	32	34.0	55.9	64.0	57.5	41.5	40.5	22	87.0	72	3.5	70	60	60	2744	TH38SMKDSOMD	160	160	160

1) Pressure shown = item deliverable

3) L = light series; 4) S = heavy series

$$\frac{\text{PN (bar)}}{10} = \text{PN (MPa)}$$

Delivery without nut and ring. Information on ordering complete fittings or alternative sealing materials see page I7.

*Please add the **suffixes** below according to the material/surface required.

Order code suffixes			
Material	Suffix surface and material	Example	Standard sealing material (no additional suffix needed)
Steel, zinc plated, chrome ²⁾ -free	CF	TH16SMKDSOMDCF	NBR
Steel, zinc yellow plated	A3C	TH16SMKDSOMDA3C	NBR
Stainless Steel	71	TH16SMKDSOMD71	VIT/PTFE

Stainless Steel only with sealing ring **KD** available!
Replace KDS by **KD** in the order code.

TH-M High pressure banjo tee

EO 24° cone end / Male metric thread with metal sealing ring

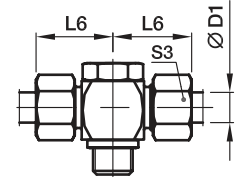
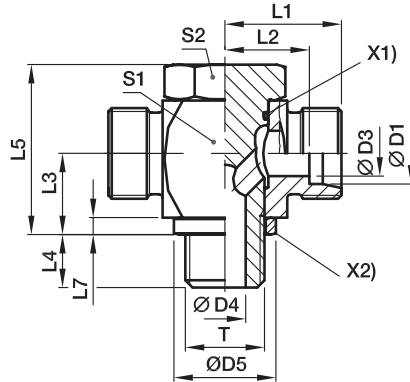

X1) O-ring OR
X2) Sealing ring DKA

Series	D1	T	D3	D4	D5	L1	L2	L3	L4	L5	L6	L7	S1	S2	S3	Weight g/1 piece	Order code*	PN (bar) ¹⁾		
																		CF	A3C	71
L ³⁾	06	M10 1	4	4.5	14	19.0	12.0	10.5	8	24.0	27	2.5	17	17	14	58	TH06LMOMD	250	250	250
	08	M12 1.5	6	6.0	17	21.5	14.5	14.0	12	30.0	29	3.0	22	19	17	104	TH08LMOMD	250	250	250
	10	M14 1.5	8	6.0	19	22.5	15.5	14.0	12	30.0	30	3.0	22	19	19	112	TH10LMOMD	250	250	250
	12	M16 1.5	10	7.5	21	25.0	18.0	16.5	12	36.0	33	3.0	27	24	22	191	TH12LMOMD	250	250	250
	15	M18 1.5	11	9.0	23	27.5	21.5	18.5	12	39.5	37	3.0	30	30	27	258	TH15LMOMD	250	250	250
	18	M22 1.5	15	12.0	27	28.5	21.0	21.5	14	45.0	37	4.5	32	30	32	337	TH18LMOMD	250	250	250
	22	M26 1.5	19	17.0	31	35.0	27.5	24.0	16	53.0	44	3.5	41	36	36	590	TH22LMOMD	160	160	160
	28	M33 2	24	21.0	39	39.5	32.0	30.5	18	66.0	49	3.5	50	46	41	1072	TH28LMOMD	160	160	160
	35	M42 2	30	27.0	49	46.5	36.0	35.5	20	76.0	58	3.5	60	55	50	1778	TH35LMOMD	160	160	160
	42	M48 2	36	34.0	55	51.5	40.5	40.5	22	87.0	63	3.5	70	60	60	2565	TH42LMOMD	160	160	160
S ⁴⁾	06	M12 1.5	4	6.0	17	23.5	16.5	14.0	12	30.0	31	3.0	22	19	17	112	TH06SMOMD	315	315	315
	08	M14 1.5	5	6.0	19	23.5	16.5	14.0	12	30.0	31	3.0	22	19	19	124	TH08SMOMD	315	315	315
	10	M16 1.5	7	7.5	21	26.0	18.5	16.5	12	36.0	35	3.0	27	24	22	200	TH10SMOMD	315	315	315
	12	M18 1.5	8	9.0	23	27.5	20.0	18.5	12	39.5	36	3.0	27	27	24	261	TH12SMOMD	315	315	315
	14	M20 1.5	10	10.0	25	30.5	22.5	20.0	14	43.5	40	3.0	32	30	27	334	TH14SMOMD	315	315	315
	16	M22 1.5	12	12.0	27	30.5	22.0	21.5	14	45.0	40	4.5	32	30	30	350	TH16SMOMD	315	315	315
	20	M27 2	16	16.0	32	37.0	26.5	24.0	16	53.0	48	3.5	41	36	36	628	TH20SMOMD	160	160	160
	25	M33 2	20	21.0	39	43.5	31.5	30.5	18	66.0	56	3.5	50	46	46	1106	TH25SMOMD	160	160	
	30	M42 2	25	27.0	49	50.5	37.0	35.5	20	76.0	64	3.5	60	55	50	1843	TH30SMOMD	160	160	160
	38	M48 2	32	34.0	55	57.5	41.5	40.5	22	87.0	72	3.5	70	60	60	2741	TH38SMOMD	160	160	160

¹⁾ Pressure shown = item deliverable

³⁾ L = light series; ⁴⁾ S = heavy series

$$\frac{PN(\text{bar})}{10} = PN(\text{MPa})$$

Delivery without nut and ring. Information on ordering complete fittings or alternative sealing materials see page I7.

*Please add the **suffixes** below according to the material/surface required.

Order code suffixes			
Material	Suffix surface and material	Example	Standard sealing material (no additional suffix needed)
Steel, zinc plated, chrome ⁶⁾ -free	CF	TH16SMOMDCF	NBR
Steel, zinc yellow plated	A3C	TH16SMOMDA3C	NBR
Stainless Steel	71	TH16SMOMD71	VIT

TH-R-KDS High pressure banjo tee

EO 24° cone end / Male BSPP thread with soft seal ring

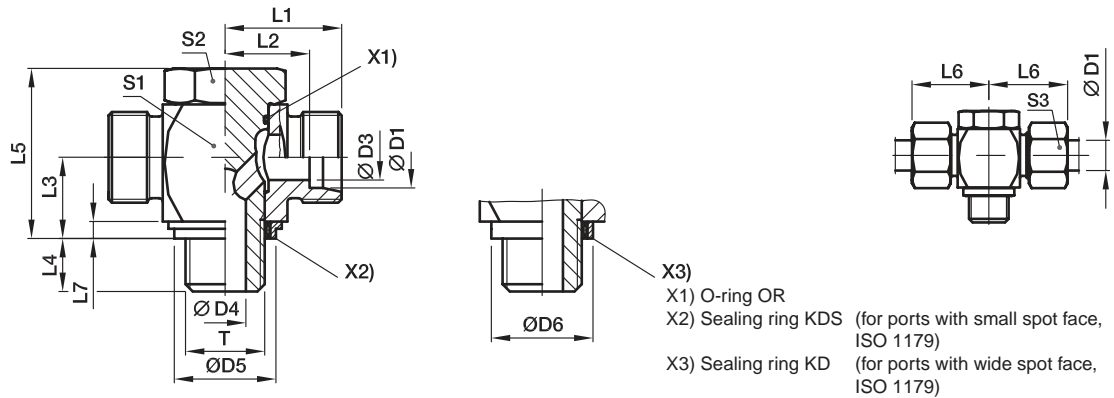

Series	D1	T	D3	D4	D5 KDS	D6 KD	L1	L2	L3	L4	L5	L6	L7	S1	S2	S3	Weight g/1 piece	Order code*	PN (bar) ¹⁾		
																			CF	A3C	71
L ³⁾	06	G 1/8 A	4	4.5	14.9	17	19.0	12.0	10.5	8	24	27	2.5	17	17	14	58	TH06LRKDSOMD	315	315	315
	08	G 1/4 A	6	6.0	18.9	22	21.5	14.5	14.0	12	30	29	3.0	22	19	17	108	TH08LRKDSOMD	315	315	315
	10	G 1/4 A	8	6.0	18.9	22	22.5	15.5	14.0	12	30	30	3.0	22	19	19	110	TH10LRKDSOMD	315	315	315
	12	G 3/8 A	10	7.5	21.9	27	25.0	18.0	16.5	12	36	33	3.0	27	24	22	193	TH12LRKDSOMD	315	315	315
	15	G 1/2 A	12	11.0	26.9	32	28.5	21.5	21.5	14	45	37	4.5	32	30	27	321	TH15LRKDSOMD	315	315	315
	18	G 1/2 A	15	11.0	26.9	32	28.5	21.0	21.5	14	45	37	4.5	32	30	32	329	TH18LRKDSOMD	315	315	315
	22	G 3/4 A	19	17.0	32.9	41	35.0	27.5	24.0	16	53	44	3.5	41	36	36	585	TH22LRKDSOMD	160	160	160
	28	G 1 A	24	21.0	39.9	46	39.5	32.0	30.5	18	66	49	3.5	50	46	41	1090	TH28LRKDSOMD	160	160	160
	35	G 1 1/4 A	30	27.0	49.9	57	46.5	36.0	35.5	20	76	58	3.5	60	55	50	1765	TH35LRKDSOMD	160	160	160
	42	G 1 1/2 A	36	34.0	55.9	64	51.5	40.5	40.5	22	87	63	3.5	70	60	60	2545	TH42LRKDSOMD	160	160	160
S ⁴⁾	06	G 1/4 A	4	6.0	18.9	22	23.5	16.5	14.0	12	30	31	3.0	22	19	17	116	TH06SRKDSOMD	400	400	400
	08	G 1/4 A	5	6.0	18.9	22	23.5	16.5	14.0	12	30	31	3.0	22	19	19	121	TH08SRKDSOMD	400	400	400
	10	G 3/8 A	7	7.5	21.9	27	26.0	18.5	16.5	12	36	35	3.0	27	24	22	201	TH10SRKDSOMD	400	400	400
	12	G 3/8 A	8	7.5	21.9	27	26.0	18.5	16.5	12	36	35	3.0	27	24	24	207	TH12SRKDSOMD	400	400	400
	14	G 1/2 A	10	11.0	26.9	32	30.5	22.5	21.5	15	45	40	4.5	32	30	27	338	TH14SRKDSOMD	400	400	400
	16	G 1/2 A	12	11.0	26.9	32	30.5	22.0	21.5	14	45	40	4.5	32	30	30	350	TH16SRKDSOMD	315	315	315
	20	G 3/4 A	16	17.0	32.9	41	37.0	26.5	24.0	16	53	48	3.5	41	36	36	620	TH20SRKDSOMD	315	315	315
	25	G 1 A	20	21.0	39.9	46	43.5	31.5	30.5	18	66	56	3.5	50	46	46	1124	TH25SRKDSOMD	250	250	250
	30	G 1 1/4 A	25	27.0	49.9	57	50.5	37.0	35.5	20	76	64	3.5	60	55	50	1830	TH30SRKDSOMD	160	160	160
	38	G 1 1/2 A	32	34.0	55.9	64	57.5	41.5	40.5	22	87	72	3.5	70	60	60	2721	TH38SRKDSOMD	160	160	160

1) Pressure shown = item deliverable

3) L = light series; 4) S = heavy series

PN (bar) = PN (MPa)
10

Delivery without nut and ring. Information on ordering complete fittings or alternative sealing materials see page I7.

*Please add the **suffixes** below according to the material/surface required.

Order code suffixes			
Material	Suffix surface and material	Example	Standard sealing material (no additional suffix needed)
Steel, zinc plated, chrome ²⁾ -free	CF	TH16SRKDSOMDCF	NBR
Steel, zinc yellow plated	A3C	TH16SRKDSOMDA3C	NBR
Stainless Steel	71	TH16SRKDOMD71	VIT/PTFE

Stainless Steel only with sealing ring KD available!
 Replace KDS by KD in the order code.

TH-R High pressure banjo tee

EO 24° cone end / Male BSPP thread with metal sealing ring

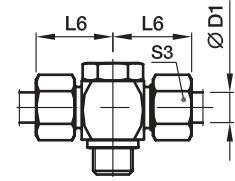
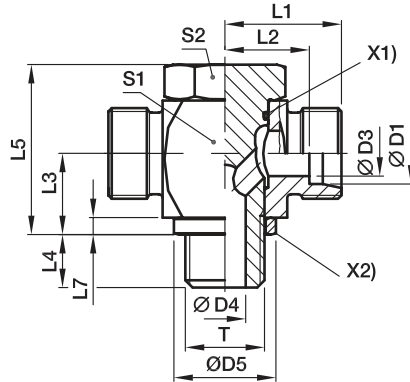

X1) O-ring OR
X2) Sealing ring DKA

Series	D1	T	D3	D4	D5	L1	L2	L3	L4	L5	L6	L7	S1	S2	S3	Weight g/1 piece	Order code*	PN (bar) ¹⁾		
																		CF	A3C	71
L ³⁾	06	G 1/8 A	4	4.5	14	19.0	12.0	10.5	8	24	27	2.5	17	17	14	58	TH06LROMD	250	250	250
	08	G 1/4 A	6	6.0	18	21.5	14.5	14.0	12	30	29	3.0	22	19	17	108	TH08LROMD	250	250	250
	10	G 1/4 A	8	6.0	18	22.5	15.5	14.0	12	30	30	3.0	22	19	19	110	TH10LROMD	250	250	250
	12	G 3/8 A	10	7.5	22	25.0	18.0	16.5	12	36	33	3.0	27	24	22	193	TH12LROMD	250	250	250
	15	G 1/2 A	12	11.0	26	28.5	21.5	21.5	14	45	37	4.5	32	30	27	321	TH15LROMD	250	250	250
	18	G 1/2 A	15	11.0	26	28.5	21.0	21.5	14	45	37	4.5	32	30	32	329	TH18LROMD	250	250	250
	22	G 3/4 A	19	17.0	32	35.0	27.5	24.0	16	53	44	3.5	41	36	36	584	TH22LROMD	160	160	160
	28	G 1 A	24	21.0	39	39.5	32.0	30.5	18	66	49	3.5	50	46	41	1090	TH28LROMD	160	160	160
	35	G 1 1/4 A	30	27.0	57	46.5	36.0	35.5	20	76	58	3.5	60	55	50	1766	TH35LROMD	160	160	160
	42	G 1 1/2 A	36	34.0	55	51.5	40.5	40.5	22	87	63	3.5	70	60	60	2544	TH42LROMD	160	160	160
S ⁴⁾	06	G 1/4 A	4	6.0	18	23.5	16.5	14.0	12	30	31	3.0	22	19	17	116	TH06SROMD	315	315	315
	08	G 1/4 A	5	6.0	18	23.5	16.5	14.0	12	30	31	3.0	22	19	19	121	TH08SROMD	315	315	315
	10	G 3/8 A	7	7.5	22	26.0	18.5	16.5	12	36	35	3.0	27	24	22	201	TH10SROMD	315	315	315
	12	G 3/8 A	8	7.5	22	26.0	18.5	16.5	12	36	35	3.0	27	24	24	207	TH12SROMD	315	315	315
	14	G 1/2 A	10	11.0	26	30.5	22.5	21.5	14	45	40	4.5	32	30	27	343	TH14SROMD	315	315	315
	16	G 1/2 A	12	11.0	26	30.5	22.0	21.5	14	45	40	4.5	32	30	30	350	TH16SROMD	315	315	315
	20	G 3/4 A	16	17.0	32	37.0	26.5	24.0	16	53	48	3.5	41	36	36	618	TH20SROMD	160	160	160
	25	G 1 A	20	21.0	39	43.5	31.5	30.5	18	66	56	3.5	50	46	46	1124	TH25SROMD	160	160	160
	30	G 1 1/4 A	25	27.0	49	50.5	37.0	35.5	20	76	64	3.5	60	55	50	1831	TH30SROMD	160	160	160
	38	G 1 1/2 A	32	34.0	55	57.5	41.5	40.5	22	87	72	3.5	70	60	60	2720	TH38SROMD	160	160	160

¹⁾ Pressure shown = item deliverable

³⁾ L = light series; ⁴⁾ S = heavy series

$\frac{PN \text{ (bar)}}{10} = PN \text{ (MPa)}$

Delivery without nut and ring. Information on ordering complete fittings or alternative sealing materials see page I7.

*Please add the **suffixes** below according to the material/surface required.

Order code suffixes			
Material	Suffix surface and material	Example	Standard sealing material (no additional suffix needed)
Steel, zinc plated, chrome ⁶⁾ -free	CF	TH16SROMDCF	NBR
Steel, zinc yellow plated	A3C	TH16SROMDA3C	NBR
Stainless Steel	71	TH16SROMD71	VIT

SWVE-M Banjo elbow

EO 24° cone end / Male metric thread

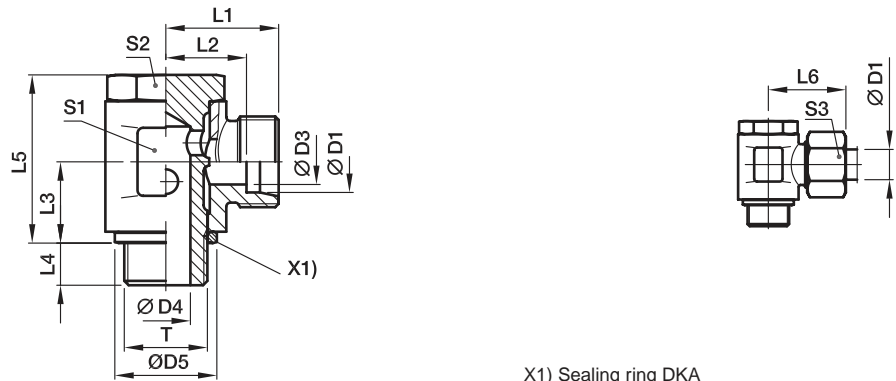

Series	D1	T	D3	D4	D5	L1	L2	L3	L4	L5	L6	S1	S2	S3	Weight g/1 piece	Order code*	PN (bar) ¹⁾	
																	CF	A3C
LL ²⁾	04	M08 1	3.0	3.0	12.5	14.5	10.5	8.0	6	17.0	20	12	12	10	18	SWVE04LLMOMD	63	63
	06	M10 1	4.5	5.0	14.0	15.5	10.0	10.0	6	21.0	22	14	14	12	29	SWVE06LLMOMD	63	63
	08	M10 1	6.0	5.0	14.0	16.5	11.0	10.0	6	21.0	23	14	14	14	31	SWVE08LLMOMD	63	63
L ³⁾	06	M10 1	4.5	5.0	14.0	15.5	10.5	10.0	6	21.5	25	14	14	14	31	SWVE06LMOMD	160	160
	08	M12 1.5	6.0	6.0	17.0	19.0	12.0	12.0	9	25.0	27	17	17	17	51	SWVE08LMOMD	160	160
	10	M14 1.5	8.0	6.5	19.0	21.0	14.0	13.0	9	27.0	29	19	19	19	68	SWVE10LMOMD	160	160
	12	M16 1.5	10.0	8.5	21.0	22.5	15.5	15.0	9	32.0	30	22	21	22	100	SWVE12LMOMD	100	100
	15	M18 1.5	12.0	11.0	23.0	24.5	17.5	18.0	9	37.5	33	24	24	27	138	SWVE15LMOMD	100	100
	18	M22 1.5	15.0	13.0	27.0	28.0	20.5	21.5	11	44.0	37	30	27	32	241	SWVE18LMOMD	100	100
	22	M26 1.5	19.0	18.0	31.0	33.0	25.5	24.0	13	49.0	42	36	32	36	351	SWVE22LMOMD	100	100
S ⁴⁾	06	M12 1.5	4.0	6.0	17.0	21.0	14.0	12.0	9	25.0	29	17	17	17	55	SWVE06SMOMD	160	160
	08	M14 1.5	5.0	6.5	19.0	22.0	15.0	13.0	9	27.0	30	19	19	19	75	SWVE08SMOMD	160	160
	10	M16 1.5	7.0	8.5	21.0	23.5	16.0	15.0	9	32.0	32	22	22	22	106	SWVE10SMOMD	100	100
	12	M18 1.5	8.0	11.0	23.0	24.5	17.0	18.0	9	37.0	33	24	24	24	134	SWVE12SMOMD	100	100
	14	M20 1.5	10.0	10.0	25.0	28.0	20.0	18.0	11	37.0	38	27	27	27	179	SWVE14SMOMD	100	100
	16	M22 1.5	12.0	13.0	27.0	30.0	21.5	21.5	11	44.0	40	30	27	30	252	SWVE16SMOMD	100	100
	20	M27 2	16.0	18.0	32.0	35.0	24.5	24.0	13	49.0	46	36	32	36	363	SWVE20SMOMD	100	100

¹⁾ Pressure shown = item deliverable

²⁾ LL = very light series; ³⁾ L = light series; ⁴⁾ S = heavy series

$$\frac{PN \text{ (bar)}}{10} = PN \text{ (MPa)}$$

Delivery without nut and ring. Information on ordering complete fittings see page 17.

*Please add the **suffixes** below according to the material/surface required.

Order code suffixes			
Material	Suffix surface and material	Example	Standard sealing material (no additional suffix needed)
Steel, zinc plated, chrome ⁶ -free	CF	SWVE16SMOMDCF	NBR
Steel, zinc yellow plated	A3C	SWVE16SMOMDA3C	NBR

SWVE-R Banjo elbow

EO 24° cone end / Male BSPP thread

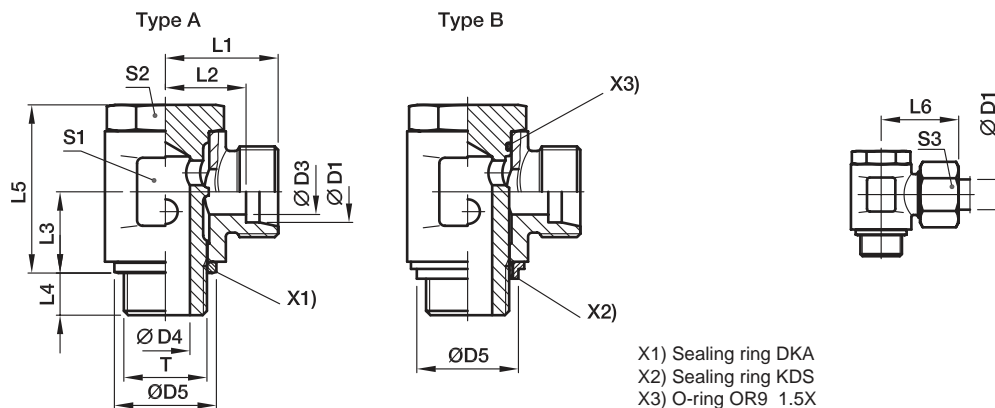

Series	D1	Type	T	D3	D4	D5	L1	L2	L3	L4	L5	L6	S1	S2	S3	Weight g/1 piece	Order code*	PN (bar) ¹⁾	
																		CF	A3C
LL ²⁾	04	B	G 1/8A	3.0	5.0	15	15.5	11.5	10.0	6	21.5	21	14	14	10	29	SWVE04LLRKDSOMD	250	250
	06	B	G 1/8A	4.5	5.0	15	15.5	10.0	10.0	6	21.5	22	14	14	12	30	SWVE06LLRKDSOMD	250	250
LL ²⁾	04	A	G 1/8A	3.0	5.0	14	15.5	11.5	10.0	6	21.0	21	14	14	10	28	SWVE04LLROMD	63	63
	06	A	G 1/8A	4.5	5.0	14	15.5	10.0	10.0	6	21.5	22	14	14	12	28	SWVE06LLROMD	63	63
	08	A	G 1/8A	6.0	5.0	14	16.5	11.0	10.0	6	21.0	23	14	14	14	30	SWVE08LLROMD	63	63
L ³⁾	06	A	G 1/8A	4.0	5.0	14	17.5	10.5	10.0	6	21.0	25	14	14	14	31	SWVE06LRROMD	160	160
	08	A	G 1/4A	6.0	6.5	18	20.0	13.0	13.0	9	27.0	28	19	19	17	65	SWVE08LRROMD	160	160
	10	A	G 1/4A	8.0	6.5	18	21.0	14.0	13.0	9	27.0	29	19	19	19	66	SWVE10LRROMD	160	160
	12	A	G 3/8A	10.0	8.5	22	22.5	15.5	15.0	9	32.0	30	22	22	22	102	SWVE12LRROMD	100	100
	15	A	G 1/2A	12.0	11.0	26	26.0	19.0	18.0	11	37.5	34	27	27	27	171	SWVE15LRROMD	100	100
	18	A	G 1/2A	15.0	12.0	26	28.0	20.5	21.5	11	44.0	37	30	27	32	249	SWVE18LRROMD	100	100
S ⁴⁾	06	A	G 1/4A	4.0	6.5	18	22.0	15.0	13.0	9	27.0	30	19	19	17	69	SWVE06SRROMD	160	160
	08	A	G 1/4A	5.0	6.5	18	22.0	15.0	13.0	9	27.0	30	19	19	19	73	SWVE08SRROMD	160	160
	10	A	G 3/8A	7.0	8.5	22	23.5	16.0	15.0	9	32.0	32	22	22	22	108	SWVE10SRROMD	100	100
	12	A	G 3/8A	8.0	8.0	22	24.5	17.0	18.0	9	37.0	33	24	24	24	147	SWVE12SRROMD	100	100
	14	A	G 1/2A	10.0	11.0	26	28.0	20.0	18.0	11	37.0	38	27	27	27	177	SWVE14SRROMD	100	100
	16	A	G 1/2A	12.0	12.0	26	30.0	21.5	21.5	11	44.0	40	30	27	30	249	SWVE16SRROMD	100	100
	20	A	G 3/4A	16.0	18.0	32	35.0	24.5	24.0	13	49.0	46	36	32	36	359	SWVE20SRROMD	100	100

¹⁾ Pressure shown = item deliverable

²⁾ LL = very light series; ³⁾ L = light series; ⁴⁾ S = heavy series

$$\frac{\text{PN (bar)}}{10} = \text{PN (MPa)}$$

Delivery without nut and ring. Information on ordering complete fittings or alternative sealing materials see page I7.

Order code suffixes			
Material	Suffix surface and material	Example	Standard sealing material (no additional suffix needed)
Steel, zinc plated, chrome ⁶ -free	CF	SWVE16SRROMDCF	
Steel, zinc yellow plated	A3C	SWVE16SRROMDA3C	
Steel, zinc plated, chrome ⁶ -free	CF	SWVE06LLRKDSOMDCF	NBR
Steel, zinc yellow plated	A3C	SWVE06LLRKDSOMDA3C	NBR

*Please add the **suffixes** below according to the material/surface required.

DSVW-M Low pressure banjo elbow

EO 24° cone end / Male metric thread

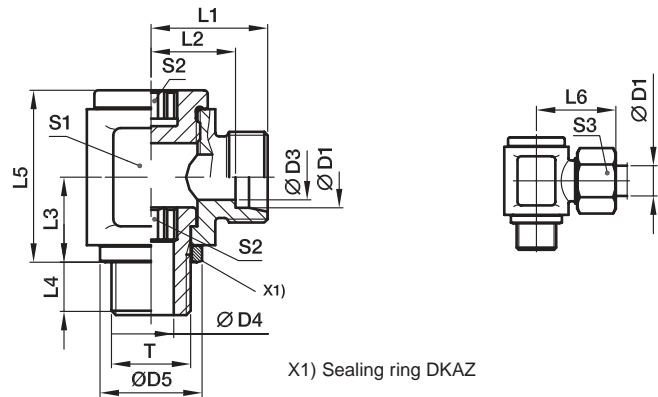

Series	D1	T	D3	D4	D5	L1	L2	L3	L4	L5	L6	S1	S2	S3	Weight g/1 piece	Order code*	PN (bar) ¹⁾	
																	CF	A3C
L ³⁾	06	M 10 1	4	4.0	14	19.5	12.5	12	8	24	27	18	6	14	51	DSVW06LMOMD	160	160
	08	M 12 1.5	6	5.5	17	21.5	14.5	15	12	30	29	22	6	17	86	DSVW08LMOMD	160	160
	10	M 14 1.5	8	7.0	19	22.5	15.5	16	12	30	30	22	8	19	87	DSVW10LMOMD	100	100
	12	M 16 1.5	10	8.0	21	25.0	18.0	18	12	37	33	27	10	22	145	DSVW12LMOMD	100	100
	15	M 18 1.5	12	10.0	23	28.0	21.0	20	12	40	36	30	12	27	197	DSVW15LMOMD	100	100
	18	M 22 1.5	15	14.0	27	29.0	21.5	23	14	46	38	36	14	32	264	DSVW18LMOMD	100	100
	22	M 26 1.5	19	17.5	31	33.5	26.0	25	16	51	42	41	17	36	379	DSVW22LMOMD	100	100
	28	M 33 2	24	22.0	39	39.0	31.5	32	18	64	48	50	22	41	682	DSVW28LMOMD	100	100
	35	M 42 2	30	27.5	49	46.0	35.5	37	20	76	57	60	27	50	1146	DSVW35LMOMD	63	63
	42	M 48 2	36	32.5	55	51.0	40.0	42	22	85	63	70	32	60	1706	DSVW42LMOMD	63	63
S ⁴⁾	06	M 12 1.5	4	5.5	17	23.5	16.5	15	12	30	31	22	6	17	90	DSVW06SMOMD	160	160
	08	M 14 1.5	5	7.0	19	23.5	16.5	16	12	30	31	22	8	19	90	DSVW08SMOMD	160	160
	10	M 16 1.5	7	8.0	21	26.0	18.5	18	12	37	35	27	10	22	154	DSVW10SMOMD	100	100
	12	M 18 1.5	8	10.0	23	28.0	20.5	20	12	41	37	30	12	24	199	DSVW12SMOMD	100	100
	14	M 20 1.5	10	12.0	25	31.0	23.0	21	14	42	41	32	12	27	239	DSVW14SMOMD	100	100
	16	M 22 1.5	12	14.0	27	31.0	22.5	23	14	46	41	36	14	30	268	DSVW16SMOMD	100	100
	20	M 27 2	16	17.5	32	38.0	27.5	28	16	58	49	46	17	36	532	DSVW20SMOMD	100	100
	25	M 33 2	20	22.0	39	43.0	31.0	32	18	64	55	50	22	46	728	DSVW25SMOMD	100	100
	30	M 42 2	25	27.5	49	40.0	36.5	37	20	76	63	60	27	50	1222	DSVW30SMOMD	63	63
	38	M 48 2	32	32.5	55	56.0	41.0	42	22	85	72	70	32	60	1820	DSVW38SMOMD	63	63

¹⁾ Pressure shown = item deliverable

³⁾ L = light series; ⁴⁾ S = heavy series

$\frac{PN(\text{bar})}{10} = PN(\text{MPa})$

Delivery without nut and ring. Information on ordering complete fittings see page 17.

*Please add the **suffixes** below according to the material/surface required.

Order code suffixes		
Material	Suffix surface and material	Example
Steel, zinc plated, chrome ⁶ -free	CF	DSVW16SMOMDCF
Steel, zinc yellow plated	A3C	DSVW16SMOMDA3C

DSVW-R Low pressure banjo elbow

EO 24° cone end / Male BSPP thread

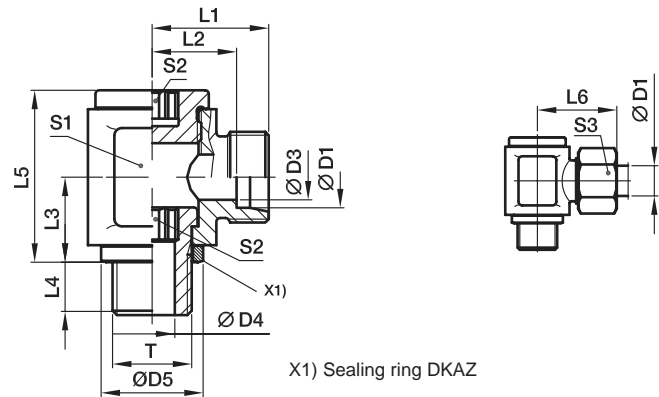

Series	D1	T	D3	D4	D5	L1	L2	L3	L4	L5	L6	S1	S2	S3	Weight g/1 piece	Order code*	PN (bar) ¹⁾	
																	CF	A3C
L ³⁾	06	G 1/8 A	4	4.0	14	19.5	12.5	12	8	24	27	14	18	6	51	DSVW06LROMD	160	160
	08	G 1/4 A	6	6.0	18	21.5	14.5	16	12	30	29	17	22	8	85	DSVW08LROMD	160	160
	10	G 1/4 A	8	6.0	18	22.5	15.5	16	12	30	30	19	22	8	88	DSVW10LROMD	100	100
	12	G 3/8 A	10	8.5	22	25.0	18.0	18	12	37	33	22	27	10	147	DSVW12LROMD	100	100
	15	G 1/2 A	12	12.0	26	29.0	22.0	21	14	42	37	27	32	12	228	DSVW15LROMD	100	100
	18	G 1/2 A	15	12.0	26	29.0	21.5	23	14	46	38	32	36	12	276	DSVW18LROMD	100	100
	22	G 3/4 A	19	17.5	32	36.0	28.5	28	16	58	45	36	46	17	516	DSVW22LROMD	100	100
	28	G 1 A	24	22.0	39	39.0	31.5	32	18	64	48	41	50	22	688	DSVW28LROMD	100	100
	35	G 1 1/4 A	30	27.5	49	46.0	35.5	37	20	76	57	50	60	27	1147	DSVW35LROMD	63	63
	42	G 1 1/2 A	36	32.5	55	51.5	40.0	42	22	85	63	60	70	32	1696	DSVW42LROMD	63	63
S ⁴⁾	06	G 1/4 A	4	6.0	18	23.5	16.5	16	12	30	31	17	22	8	89	DSVW06SROMD	160	160
	08	G 1/4 A	5	6.0	18	23.5	16.5	16	12	30	31	19	22	8	92	DSVW08SROMD	160	160
	10	G 3/8 A	7	8.5	22	26.0	18.5	18	12	37	35	22	27	10	150	DSVW10SROMD	100	100
	12	G 3/8 A	8	8.5	22	26.0	18.5	18	12	37	35	24	27	10	156	DSVW12SROMD	100	100
	14	G 1/2 A	10	12.0	26	31.0	23.0	21	14	42	41	27	32	12	235	DSVW14SROMD	100	100
	16	G 1/2 A	12	12.0	26	31.0	22.5	23	14	46	41	30	36	12	275	DSVW16SROMD	100	100
	20	G 3/4 A	16	17.5	32	38.0	27.5	28	16	58	49	36	46	17	530	DSVW20SROMD	100	100
	25	G 1 A	20	22.0	39	43.0	31.0	32	18	64	55	46	50	22	734	DSVW25SROMD	100	100
	30	G 1 1/4 A	25	27.5	49	50.0	36.5	37	20	76	63	50	60	27	1224	DSVW30SROMD	63	63
	38	G 1 1/2 A	32	32.5	55	57.5	41.0	42	22	85	72	60	70	32	1810	DSVW38SROMD	63	63

¹⁾ Pressure shown = item deliverable

³⁾ L = light series; ⁴⁾ S = heavy series

$$\frac{\text{PN (bar)}}{10} = \text{PN (MPa)}$$

Delivery without nut and ring. Information on ordering complete fittings see page 17.

*Please add the **suffixes** below according to the material/surface required.

Order code suffixes		
Material	Suffix surface and material	Example
Steel, zinc plated, chrome ⁶ -free	CF	DSVW16SROMDCF
Steel, zinc yellow plated	A3C	DSVW16SROMDA3C

WE-NPT Male stud elbow

EO 24° cone end / Male NPT thread (SAE J476)

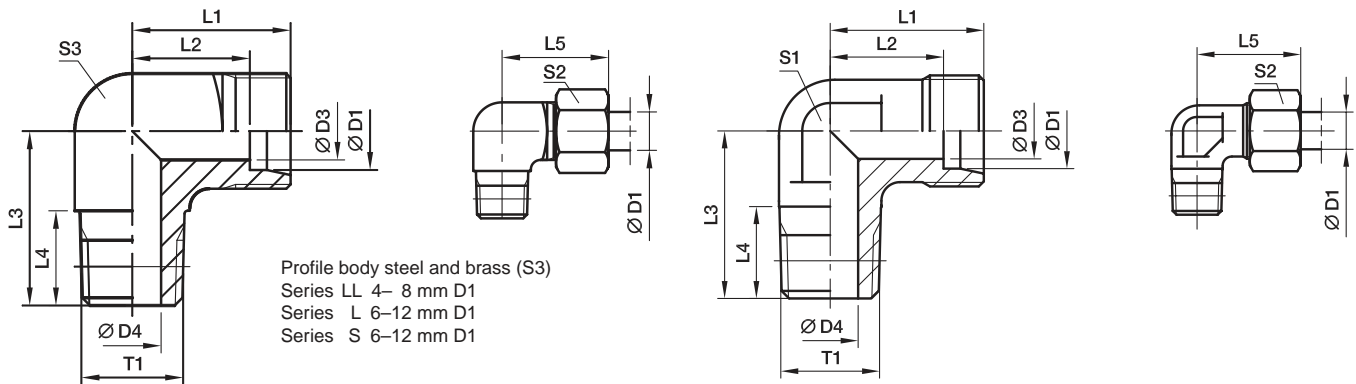

Series	D1	T1	D3	D4	L1	L2	L3	L4	L5	S1	S2	S3	Weight g/1 piece	Order code*	PN (bar) ¹⁾			
															CF	A3C	71	MS
LL ²⁾	04	1/8-27NPT	3.0	4.0	15	11.0	17	10.0	21	9	10	11	18	WE04LL1/8NPT	100	100		
	06	1/8-27NPT	4.5	4.5	15	9.5	17	10.0	21	9	12	11	17	WE06LL1/8NPT	100	100		
	08	1/8-27NPT	6.0	5.0	17	11.5	20	10.0	23	12	14	12	25	WE08LL1/8NPT	100	100		
L ³⁾	06	1/8-27NPT	4.0	4.0	19	12.0	20	10.0	27	12	14	12	29	WE06L1/8NPT	315	315	315	315
	06	1/4-18NPT	4.0	7.0	21	14.0	26	14.5	29	12	14	14	44	WE06L1/4NPT	315	315	315	315
	06	3/8-18NPT	4.0	8.0	25	18.0	28	14.5	33	17	14	19	55	WE06L3/8NPT	315	315	315	315
	08	1/8-27NPT	6.0	4.0	21	14.0	26	10.0	29	12	17	14	48	WE08L1/8NPT	315	315	315	315
	08	1/4-18NPT	6.0	6.0	21	14.0	26	14.5	29	12	17	14	47	WE08L1/4NPT	315	315	315	315
	10	1/4-18NPT	8.0	7.0	22	15.0	27	14.5	30	14	19	17	61	WE10L1/4NPT	315	315	315	315
	10	3/8-18NPT	8.0	8.0	24	17.0	28	14.5	32	17	19	19	92	WE10L3/8NPT	315	315	315	315
	12	1/4-18NPT	10.0	7.0	24	17.0	28	14.5	32	17	22	19	82	WE12L1/4NPT	315	315	315	315
	12	3/8-18NPT	10.0	8.0	24	17.0	28	14.5	32	17	22	19	92	WE12L3/8NPT	315	315	315	315
	12	1/2-14NPT	10.0	11.0	28	21.0	34	19.5	36	19	22		90	WE12L1/2NPT	315	315	315	315
	15	1/2-14NPT	12.0	11.0	28	21.0	34	19.5	36	19	27		89	WE15L1/2NPT	315	315	315	315
	18	1/2-14NPT	15.0	12.0	31	23.5	36	19.5	40	24	32		150	WE18L1/2NPT	315	315	315	315
	22	3/4-14NPT	19.0	16.0	35	27.5	42	19.5	44	27	36		176	WE22L3/4NPT	160	160	160	160
	28	1-11 1/2NPT	24.0	21.0	38	30.5	48	24.5	47	36	41		314	WE28L1NPT	160	160	160	160
	35	11/4-11 1/2NPT	30.0	28.0	45	34.5	54	25.0	56	41	50		465	WE35L11/4NPT	160	160	160	160
42	11/2-11 1/2NPT	36.0	34.0	51	40.0	61	26.0	63	50	60		849	WE42L11/2NPT	160	160	160	160	
S ⁴⁾	06	1/4-18NPT	4.0	4.0	23	16.0	26	14.5	31	12	17	14	56	WE06S1/4NPT	630	630	630	630
	08	1/4-18NPT	5.0	5.0	24	17.0	27	14.5	32	14	19	17	73	WE08S1/4NPT	630	630	630	630
	08	3/8-18NPT	5.0	8.0	25	18.0	28	14.5	33	17	19	19	77	WE08S3/8NPT	630	630	630	630
	08	1/2-14NPT	5.0	10.0	30	23.0	34	19.5	38	19	19		75	WE08S1/2NPT	630	630	630	630
	10	1/4-18NPT	7.0	5.0	25	17.5	28	14.5	34	17	22	19	96	WE10S1/4NPT	630	630	630	630
	10	3/8-18NPT	7.0	7.0	25	17.5	28	14.5	34	17	22	19	98	WE10S3/8NPT	630	630	630	630
	12	1/4-18NPT	8.0	5.0	29	21.5	29	14.5	38	17	24	22	73	WE12S1/4NPT	630	630	630	630
	12	3/8-18NPT	8.0	8.0	29	22.5	28	14.5	38	17	24	22	123	WE12S3/8NPT	630	630	630	630
	12	1/2-14NPT	8.0	10.0	30	22.5	34	19.5	39	19	24		107	WE12S1/2NPT	630	630	630	630
	14	1/2-14NPT	10.0	10.0	30	22.0	34	19.5	40	19	27		103	WE14S1/2NPT	630	630	630	630
	16	1/2-14NPT	12.0	12.0	33	24.5	36	19.5	43	24	30		157	WE16S1/2NPT	400	400	400	400
	20	3/4-11NPT	16.0	16.0	37	26.5	42	19.5	48	27	36		205	WE20S3/4NPT	400	400	400	400
	25	1-11 1/2NPT	20.0	20.0	42	30.0	48	24.5	54	36	46		381	WE25S1NPT	400	400	400	400
	30	11/4-11 1/2NPT	25.0	25.0	49	35.5	54	25.0	62	41	50		598	WE30S11/4NPT	400	400	400	400
	38	11/2-11 1/2NPT	32.0	32.0	57	41.0	61	26.0	72	50	60		1029	WE38S11/2NPT	315	315	315	315

1) Pressure shown = item deliverable

2) LL = very light series; 3) L = light series; 4) S = heavy series

PN (bar) = PN (MPa)
 10

Delivery without nut and ring. Information on ordering complete fittings see page 17.

*Please add the suffixes below according to the material/surface required.

Order code suffixes		
Material	Suffix surface and material	Example
Steel, zinc plated, chrome ⁶ -free	CFX	WE16S1/2NPTCFX
Steel, zinc yellow plated	A3CX	WE16S1/2NPTA3CX
Stainless Steel	71X	WE16S1/2NPT71X
Brass	MSX	WE16S1/2NPTMSX

WE-M(KEG) Male stud elbow

EO 24° cone end / Male short metric taper thread (DIN 3852-1, type C)

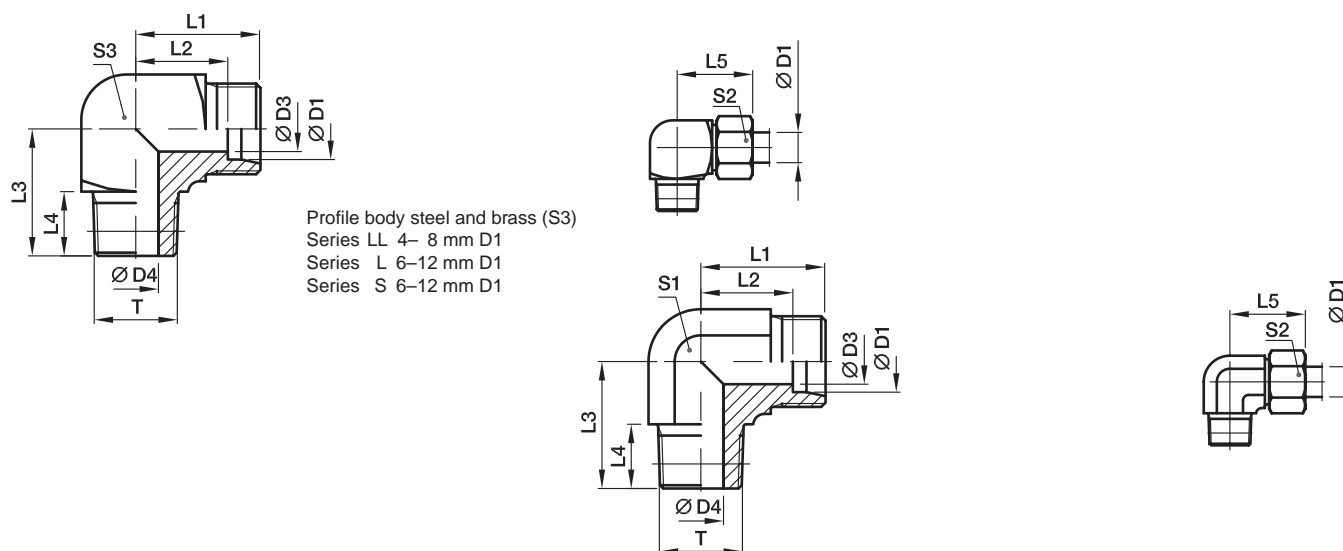

Profile body steel and brass (S3)
 Series LL 4– 8 mm D1
 Series L 6–12 mm D1
 Series S 6–12 mm D1

Series	D1	T	D3	D4	L1	L2	L3	L4	L5	S1	S2	S3	Weight g/1 piece	Order code*	PN (bar) ¹⁾			
															CF	A3C	71	MS
LL ²⁾	04	M8 1tap.	3.0	3.5	15	11.0	17	8	21	9	10	9	14	WE04LLM	100	100	100	63
	06	M10 1tap.	4.5	4.5	15	9.5	17	8	21	9	12	11	17	WE06LLM	100	100	100	63
	08	M10 1tap.	6.0	6.0	17	11.5	20	8	23	12	14	12	25	WE08LLM	100	100	100	63
L ³⁾	06	M10 1tap.	4.0	4.0	19	12.0	20	8	27	12	14	12	29	WE06LM	315	315	315	200
	08	M12 1.5tap.	6.0	6.0	21	14.0	26	12	29	12	17	14	46	WE08LM	315	315	315	200
	10	M14 1.5tap.	8.0	7.0	22	15.0	27	12	30	14	19	17	62	WE10LM	315	315	315	200
	12	M16 1.5tap.	10.0	9.0	24	17.0	28	12	32	17	22	19	89	WE12LM	315	315	315	200
	15	M18 1.5tap.	12.0	11.0	28	21.0	32	12	36	19	27		78	WE15LM	315	315	315	200
	18	M22 1.5tap.	15.0	14.0	31	23.0	36	14	40	24	32		148	WE18LM	315	315	315	200
S ⁴⁾	06	M12 1.5tap.	4.0	4.0	23	16.0	26	12	31	12	17	14	53	WE06SM	400	400	400	250
	08	M14 1.5tap.	5.0	5.0	24	17.0	27	12	32	14	19	17	78	WE08SM	400	400	400	250
	10	M16 1.5tap.	7.0	7.0	25	17.5	28	12	34	17	22	19	102	WE10SM	400	400	400	250
	12	M18 1.5tap.	8.0	8.0	29	21.5	28	12	38	17	24	22	134	WE12SM	400	400	400	250
	14	M20 1.5tap.	10.0	10.0	30	22.0	32	14	40	19	27		99	WE14SM	400	400	400	
	16	M22 1.5tap.	12.0	12.0	33	24.5	32	14	43	24	30		161	WE16SM	400	400	400	250

¹⁾ Pressure shown = item deliverable

²⁾ LL = very light series; ³⁾ L = light series; ⁴⁾ S = heavy series

$\frac{PN(\text{bar})}{10} = PN(\text{MPa})$

Delivery without nut and ring. Information on ordering complete fittings see page 17.

Order code suffixes		
Material	Suffix surface and material	Example
Steel, zinc plated, chrome ⁶ -free	CFX	WE16SMCFX
Steel, zinc yellow plated	A3CX	WE16SMA3CX
Stainless Steel	71X	WE16SM71X
Brass	MSX	WE16SMMSX

*Please add the **suffixes** below according to the material/surface required.

WE-M Male stud elbow

EO 24° cone end / Male metric thread – metal sealing edge (ISO 9974)

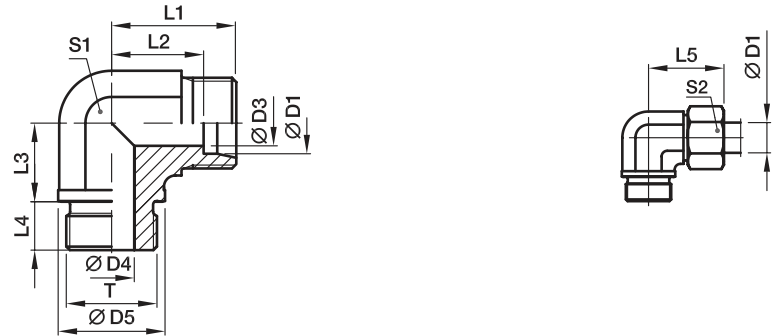

Series	D1	T	D3	D4	D5	L1	L2	L3	L4	L5	S1	S2	Weight g/1 piece	Order code*	PN (bar) ¹⁾		
															CF	A3C	71
L ³⁾	22	M26 1.5	19	18	31	35	27.5	26	16	44	27	36	173	WE22LM	160	160	160
	28	M33 2	24	23	39	38	30.5	30	18	47	36	41	303	WE28LM	160	160	160
	35	M42 2	30	30	49	45	34.5	34	20	56	41	50	469	WE35LM	160	160	160
	42	M48 2	36	36	55	51	40.0	39	22	63	50	60	661	WE42LM	160	160	160
S ⁴⁾	20	M27 2	16	16	32	37	26.5	26	16	48	27	36	208	WE20SM	400	400	400
	25	M33 2	20	20	39	42	30.0	30	18	54	36	46	396	WE25SM	250	250	250
	30	M42 2	25	25	49	49	35.5	34	20	62	41	50	632	WE30SM	160	160	160
	38	M48 2	32	32	55	57	41.0	39	22	72	50	60	907	WE38SM	160	160	160

¹⁾ Pressure shown = item deliverable

³⁾ L = light series; ⁴⁾ S = heavy series

$$\frac{\text{PN (bar)}}{10} = \text{PN (MPa)}$$

Delivery without nut and ring. Information on ordering complete fittings see page 17.

Order code suffixes		
Material	Suffix surface and material	Example
Steel, zinc plated, chrome ⁶ -free	CFX	WE20SMCFX
Steel, zinc yellow plated	A3CX	WE20SMA3CX
Stainless Steel	71X	WE20SM71X

*Please add the **suffixes** below according to the material/surface required.

WE-R Male stud elbow

EO 24° cone end / Male BSPP thread – metal sealing edge (ISO 1179)

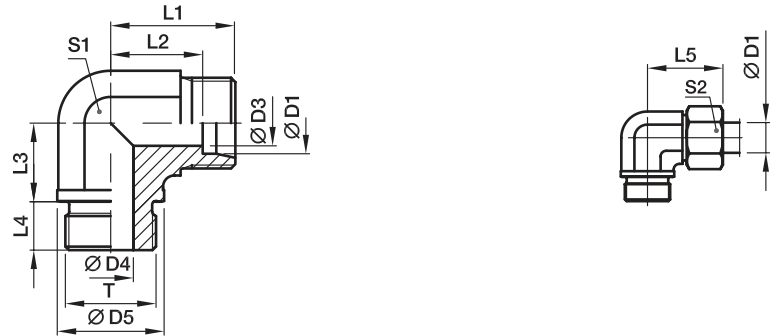

Series	D1	T	D3	D4	D5	L1	L2	L3	L4	L5	S1	S2	Weight g/1 piece	Order code*	PN (bar) ¹⁾			
															CF	A3C	71	MS
L ³⁾	22	G3/4A	19	18	32	35	27.5	26	16	44	27	36	168	WE22LR	160	160	160	100
	28	G1A	24	23	39	38	30.5	30	18	47	36	41	305	WE28LR	160	160	160	100
	35	G11/4A	30	30	49	45	34.5	34	20	56	41	50	465	WE35LR	160	160	160	100
	42	G11/2A	36	36	55	51	40.0	39	22	63	50	60	706	WE42LR	160	160	160	100
S ⁴⁾	20	G3/4A	16	16	32	37	26.5	26	16	48	27	36	210	WE20SR	400	400	400	250
	25	G1A	20	20	39	42	30.0	30	18	54	36	46	388	WE25SR	250	250	250	160
	30	G11/4A	25	25	49	49	35.5	34	20	62	41	50	630	WE30SR	160	160	160	100
	38	G11/2A	32	32	55	57	41.0	39	22	72	50	60	888	WE38SR	160	160	160	100

¹⁾ Pressure shown = item deliverable

³⁾ L = light series; ⁴⁾ S = heavy series

$\frac{PN \text{ (bar)}}{10} = PN \text{ (MPa)}$

Delivery without nut and ring. Information on ordering complete fittings see page I7.

Order code suffixes		
Material	Suffix surface and material	Example
Steel, zinc plated, chrome ⁶ -free	CFX	WE20SRCFX
Steel, zinc yellow plated	A3CX	WE20SRA3CX
Stainless Steel	71X	WE20SR71X
Brass	MSX	WE20SRMSX

*Please add the **suffixes** below according to the material/surface required.

WE-R (KEG) Male stud elbow

EO 24° cone end / Male short BSP taper thread (DIN 3852-2, type C)

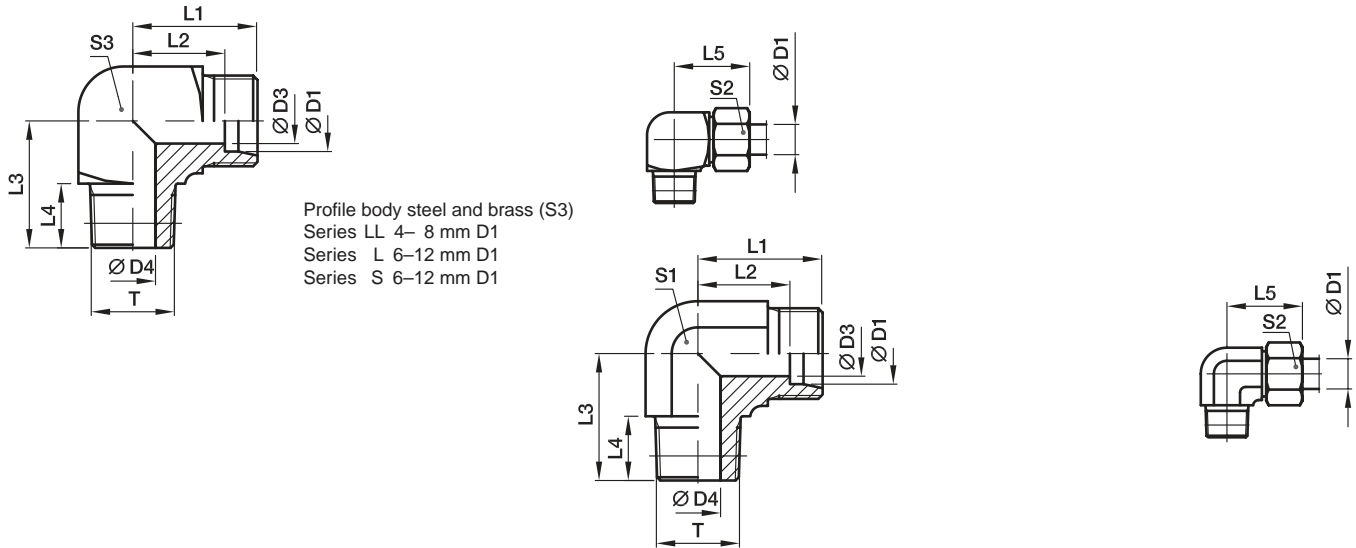

Series	D1	T	D3	D4	L1	L2	L3	L4	L5	S1	S2	S3	Weight g/1 piece	Order code*	PN (bar) ¹⁾			
															CF	A3C	71	MS
LL ²⁾	04	R1/8tap.	3.0	4.0	15	11.0	17	8	21	9	10	11	17	WE04LLR	100	100	100	63
	06	R1/8tap.	4.5	4.5	15	9.5	17	8	21	9	12	11	17	WE06LLR	100	100	100	63
	08	R1/8tap.	6.0	6.0	17	11.5	20	8	23	12	14	12	24	WE08LLR	100	100	100	63
	10	R1/4tap.	8.0	7.0	18	12.5	23	12	24	12	17	14	36	WE10LLR	100	100		
	12	R1/4tap.	10	7.0	19	13.0	23	12	25	14	19	17	46	WE12LLR	100	100		
L ³⁾	06	R1/8tap.	4.0	4.0	19	12.0	20	8	27	12	14	12	30	WE06LR	315	315	315	200
	06	R1/4tap.	4.0	6.0	21	14.0	26	12	29	12	14	14	47	WE06LR1/4	315	315	315	
	08	R1/4tap.	6.0	6.0	21	14.0	26	12	29	12	17	14	46	WE08LR	315	315	315	200
	08	R1/8tap.	6.0	4.0	21	14.0	26	8	29	12	17	14	49	WE08LR1/8	315	315	315	
	08	R3/8tap.	6.0	9.0	24	17.0	28	12	32	17	17	19	94	WE08LR3/8	315	315	315	
	10	R1/4tap.	8.0	7.0	22	15.0	27	12	30	14	19	17	61	WE10LR	315	315	315	200
	10	R3/8tap.	8.0	9.0	24	17.0	28	12	32	17	19	19	87	WE10LR3/8	315	315	315	
	12	R3/8tap.	10.0	9.0	24	17.0	28	12	32	17	22	19	88	WE12LR	315	315	315	200
	12	R1/4tap.	10.0	7.0	24	17.0	27	12	32	17	22	19	80	WE12LR1/4	315	315	315	
	12	R1/2tap.	10.0	11.0	28	21.0	34	14	36	19	22		89	WE12LR1/2	315	315	315	
	15	R1/2tap.	12.0	11.0	28	21.0	34	14	36	19	27		94	WE15LR	315	315	315	200
	18	R1/2tap.	15.0	14.0	31	23.5	36	14	40	24	32		141	WE18LR	315	315	315	200
S ⁴⁾	06	R1/4tap.	4.0	4.0	23	16.0	26	12	31	12	17	14	56	WE06SR	400	400	400	250
	06	R3/8tap.	4.0	7.0	25	18.0	28	12	33	17	17	19	61	WE06SR3/8	400	400	400	
	08	R1/4tap.	5.0	5.0	24	17.0	27	12	32	14	19	17	73	WE08SR	400	400	400	250
	08	R3/8tap.	5.0	7.0	25	18.0	28	12	33	17	19	19	63	WE08SR3/8	400	400	400	
	10	R3/8tap.	7.0	7.0	25	17.5	28	12	34	17	22	19	104	WE10SR	400	400	400	250
	10	R1/4tap.	7.0	5.0	25	17.5	28	12	34	17	22	19	59	WE10SR1/4	400	400	400	
	10	R1/2tap.	7.0	10.0	30	22.5	32	14	39	19	22		98	WE10SR1/2	400	400	400	
	12	R3/8tap.	8.0	8.0	29	21.5	28	12	38	17	24	22	126	WE12SR	400	400	400	250
	12	R1/2tap.	8.0	11.0	30	22.5	32	14	39	19	24		97	WE12SR1/2	400	400	400	
	14	R1/2tap.	10.0	10.0	30	22.0	32	14	40	19	27		101	WE14SR	400	400	400	250
	16	R1/2tap.	12.0	12.0	33	24.5	32	14	43	24	30		150	WE16SR	400	400	400	250

1) Pressure shown = item deliverable

2) LL = very light series; 3) L = light series; 4) S = heavy series

$$\frac{PN \text{ (bar)}}{10} = PN \text{ (MPa)}$$

Delivery without nut and ring. Information on ordering complete fittings see page I7.

*Please add the **suffixes** below according to the material/surface required.

Order code suffixes		
Material	Suffix surface and material	Example
Steel, zinc plated, chrome ⁶ -free	CFX	WE16SRCFX
Steel, zinc yellow plated	A3CX	WE16SRA3CX
Stainless Steel	71X	WE16SR71X
Brass	MSX	WE16SRMSX

TE-M Male stud branch tee

EO 24° cone end / Male metric thread – metal sealing edge (ISO 9974)

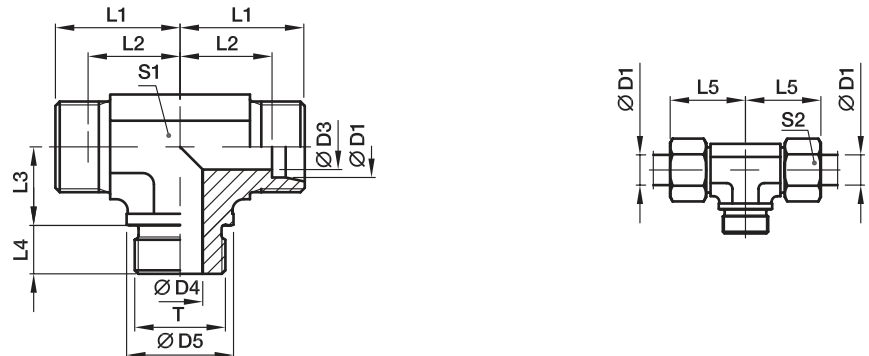

Series	D1	T	D3	D4	D5	L1	L2	L3	L4	L5	S1	S2	Weight g/1 piece	Order code*	PN (bar) ¹⁾		
															CF	A3C	71
L ³⁾	22	M26 1.5	19	18	31	35	27.5	26	16	44	27	36	208	TE22LM	160	160	160
	28	M33 2	24	23	39	38	30.5	30	18	47	36	41	352	TE28LM	160	160	160
	35	M42 2	30	30	49	45	34.5	34	20	56	41	50	554	TE35LM	160	160	160
	42	M48 2	36	36	55	51	40.0	39	22	63	50	60	847	TE42LM	160	160	160
S ⁴⁾	20	M27 2	16	16	32	37	26.5	26	16	48	27	36	265	TE20SM	400	400	400
	25	M33 2	20	20	39	42	30.0	30	18	54	36	46	482	TE25SM	250	250	250
	30	M42 2	25	25	49	49	35.5	34	20	62	41	50	772	TE30SM	160	160	160
	38	M48 2	32	32	55	57	41.0	39	22	72	50	60	1121	TE38SM	160	160	160

¹⁾ Pressure shown = item deliverable

³⁾ L = light series; ⁴⁾ S = heavy series

$\frac{PN \text{ (bar)}}{10} = PN \text{ (MPa)}$

Delivery without nut and ring. Information on ordering complete fittings see page 17.

Order code suffixes		
Material	Suffix surface and material	Example
Steel, zinc plated, chrome ⁶ -free	CFX	TE20SMCFX
Steel, zinc yellow plated	A3CX	TE20SMA3CX
Stainless Steel	71X	TE20SM71X

*Please add the **suffixes** below according to the material/surface required.

TE-R Male stud branch tee

EO 24° cone end / Male BSPP thread – metal sealing edge (ISO 1179)

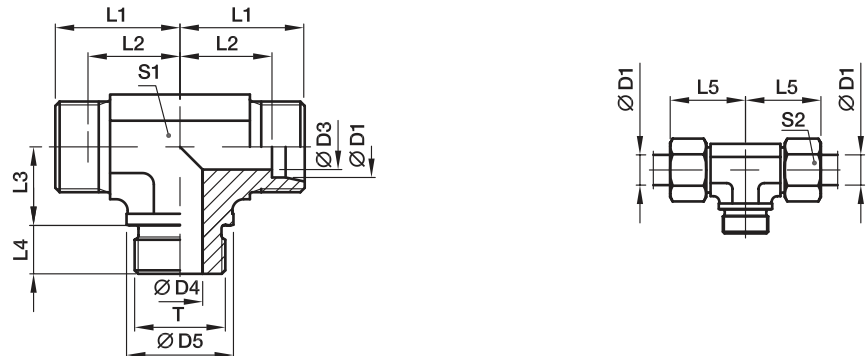

Series	D1	T	D3	D4	D5	L1	L2	L3	L4	L5	S1	S2	Weight g/1 piece	Order code*	PN (bar) ¹⁾			
															CF	A3C	71	MS
L ³⁾	22	G3/4A	19	18	32	35	27.5	26	16	44	27	36	208	TE22LR	160	160	160	100
	28	G1A	24	23	39	38	30.5	30	18	47	36	41	378	TE28LR	160	160	160	100
	35	G1 1/4 A	30	30	49	45	34.5	34	20	56	41	50	554	TE35LR	160	160	160	100
	42	G1 1/2 A	36	36	55	51	40.0	39	22	63	50	60	847	TE42LR	160	160	160	100
S ⁴⁾	20	G3/4 A	16	16	32	37	26.5	26	16	48	27	36	267	TE20SR	400	400	400	250
	25	G1A	20	20	39	42	30.0	30	18	54	36	46	485	TE25SR	250	250	250	
	30	G1 1/4 A	25	25	49	49	35.5	34	20	62	41	50	762	TE30SR	160	160	160	
	38	G1 1/2 A	32	32	55	57	41.0	39	22	72	50	60	1121	TE38SR	160	160	160	

¹⁾ Pressure shown = item deliverable

³⁾ L = light series; ⁴⁾ S = heavy series

$$\frac{\text{PN (bar)}}{10} = \text{PN (MPa)}$$

Delivery without nut and ring. Information on ordering complete fittings see page I7.

Order code suffixes		
Material	Suffix surface and material	Example
Steel, zinc plated, chrome ⁶ -free	CFX	TE20SRCFX
Steel, zinc yellow plated	A3CX	TE20SRA3CX
Stainless Steel	71X	TE20SR71X
Brass	MSX	TE20SRMSX

*Please add the **suffixes** below according to the material/surface required.

TE-R (KEG) Male stud branch tee

EO 24° cone end / Male short BSP taper thread (DIN 3852-2, type C)

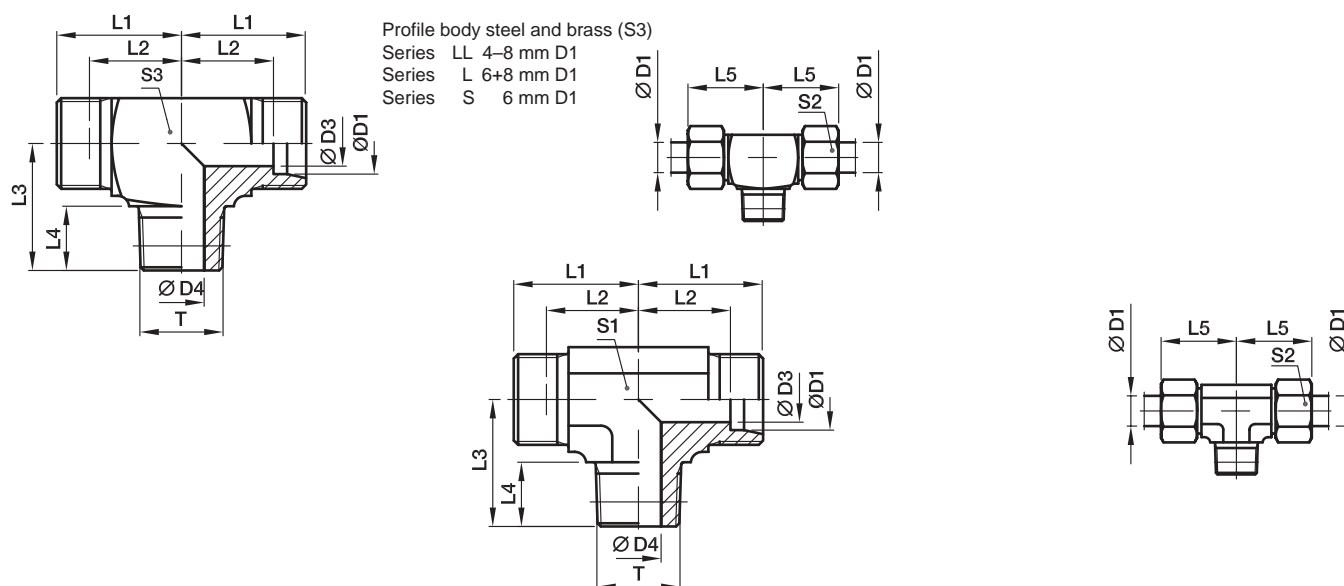

Profile body steel and brass (S3)

Series LL 4-8 mm D1

Series L 6+8 mm D1

Series S 6 mm D1

Series	D1	T	D3	D4	L1	L2	L3	L4	L5	S1	S2	S3	Weight g/1 piece	Order code*	PN (bar) ¹⁾			
															CF	A3C	71	MS
LL ²⁾	04	R1/8keg.	3.0	4.0	15	11.0	17	8	21	9	10	11	21	TE04LLR	100	100	100	63
	06	R1/8keg.	4.5	4.5	15	9.5	17	8	21	9	12	11	21	TE06LLR	100	100	100	63
	08	R1/8keg.	6.0	6.0	17	11.5	20	8	23	12	14	12	29	TE08LLR	100	100	100	63
L ³⁾	06	R1/8keg.	4.0	4.0	19	12.0	20	8	27	12	14	12	38	TE06LR	315	315	315	200
	08	R1/4keg.	6.0	6.0	21	14.0	26	12	29	12	17	14	58	TE08LR	315	315	315	200
	10	R1/4keg.	8.0	7.0	22	15.0	27	12	30	14	19		43	TE10LR	315	315	315	200
	12	R3/8keg.	10.0	9.0	24	17.0	28	12	32	17	22		61	TE12LR	315	315	315	200
	15	R1/2keg.	12.0	11.0	28	21.0	34	14	36	19	27		113	TE15LR	315	315	315	200
	18	R1/2keg.	15.0	14.0	31	23.5	36	14	40	24	32		149	TE18LR	315	315	315	200
S ⁴⁾	06	R1/4keg.	4.0	4.0	23	16.0	26	12	31	12	17	14	73	TE06SR	400	400	400	250
	08	R1/4keg.	5.0	5.0	24	17.0	27	12	32	14	19		61	TE08SR	400	400	400	250
	10	R3/8keg.	7.0	7.0	25	17.5	28	12	34	17	22		82	TE10SR	400	400	400	250
	12	R3/8keg.	8.0	8.0	29	21.5	28	12	38	17	24		105	TE12SR	400	400	400	250
	14	R1/2keg.	10.0	10.0	30	22.0	32	14	40	19	27		134	TE14SR	400	400	400	250
	16	R1/2keg.	12.0	12.0	33	24.5	32	14	43	24	30		175	TE16SR	400	400	400	250

¹⁾ Pressure shown = item deliverable

²⁾ LL = very light series; ³⁾ L = light series; ⁴⁾ S = heavy series

$\frac{PN \text{ (bar)}}{10} = PN \text{ (MPa)}$

Delivery without nut and ring. Information on ordering complete fittings see page 17.

*Please add the **suffixes** below according to the material/surface required.

Order code suffixes		
Material	Suffix surface and material	Example
Steel, zinc plated, chrome ⁶ -free	CFX	TE16SRCFX
Steel, zinc yellow plated	A3CX	TE16SRA3CX
Stainless Steel	71X	TE16SR71X
Brass	MSX	TE16SRMSX

TE-M(KEG) Male stud branch tee

EO 24° cone end / Male short metric taper thread (DIN 3852-1, type C)

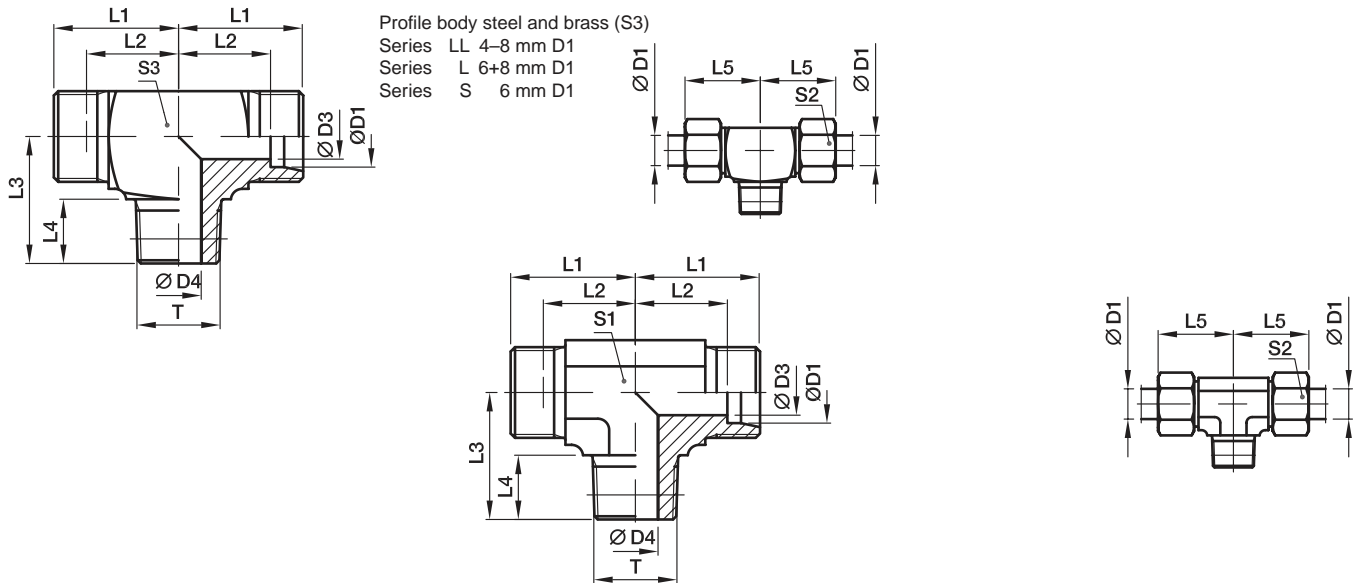

Series	D1	T	D3	D4	L1	L2	L3	L4	L5	S1	S2	S3	Weight g/1 piece	Order code*	PN (bar) ¹⁾		
															CF	A3C	71
LL ²⁾	04	M8 1tap.	3.0	3.5	15	11.0	17	8	21	9	10	9	17	TE04LLM	100	100	100
	06	M10 1tap.	4.5	4.5	15	9.5	17	8	21	9	12	11	20	TE06LLM	100	100	100
	08	M10 1tap.	6.0	6.0	17	11.5	20	8	23	12	14	12	29	TE08LLM	100	100	100
L ³⁾	06	M10 1tap.	4.0	4.0	19	12.0	20	8	27	12	14	12	38	TE06LM	315	315	315
	08	M12 1.5tap.	6.0	6.0	21	14.0	26	12	29	12	17	14	54	TE08LM	315	315	315
	10	M14 1.5tap.	8.0	7.0	22	15.0	27	12	30	14	19		45	TE10LM	315	315	315
	12	M16 1.5tap.	10.0	9.0	24	17.0	28	12	32	17	22		60	TE12LM	315	315	315
	15	M18 1.5tap.	12.0	11.0	28	21.0	32	12	36	19	27		100	TE15LM	315	315	315
	18	M22 1.5tap.	15.0	14.0	31	23.5	36	14	40	24	32		149	TE18LM	315	315	315
S ⁴⁾	06	M12 1.5tap.	4.0	4.0	23	16.0	26	12	31	12	17	14	69	TE06SM	400	400	400
	08	M14 1.5tap.	5.0	5.0	24	17.0	27	12	32	14	19		98	TE08SM	400	400	400
	10	M16 1.5tap.	7.0	7.0	25	17.5	28	12	34	17	22		82	TE10SM	400	400	400
	12	M18 1.5tap.	8.0	8.0	29	21.5	28	12	38	17	24		106	TE12SM	400	400	400
	14	M20 1.5tap.	10.0	10.0	30	22.0	32	14	40	19	27		126	TE14SM	400	400	400
	16	M22 1.5tap.	12.0	12.0	33	24.5	32	14	43	24	30		177	TE16SM	400	400	400

¹⁾ Pressure shown = item deliverable

²⁾ LL = very light series; ³⁾ L = light series; ⁴⁾ S = heavy series

$$\frac{\text{PN (bar)}}{10} = \text{PN (MPa)}$$

Delivery without nut and ring. Information on ordering complete fittings see page 17.

*Please add the **suffixes** below according to the material/surface required.

Order code suffixes		
Material	Suffix surface and material	Example
Steel, zinc plated, chrome ⁶ -free	CFX	TE16SMCFX
Steel, zinc yellow plated	A3CX	TE16SMA3CX
Stainless Steel	71X	TE16SM71X

LE-M Male stud run tee

EO 24° cone end / Male metric thread – metal sealing edge (ISO 9974)

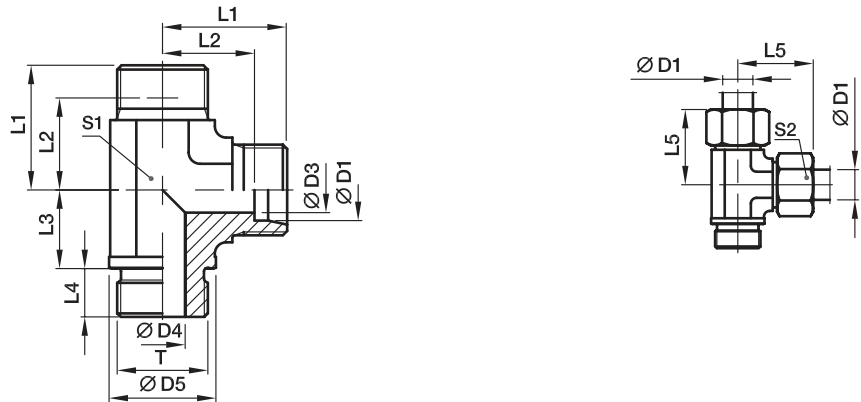

Series	D1	T	D3	D4	D5	L1	L2	L3	L4	L5	S1	S2	Weight g/1 piece	Order code*	PN (bar) ¹⁾		
															CF	A3C	71
L ³⁾	22	M26 1.5	19	18	31	35	27.5	26	16	44	27	36	225	LE22LM	160	160	160
	28	M33 2	24	23	39	38	30.5	30	18	47	36	41	382	LE28LM	160	160	160
	35	M42 2	30	30	49	45	34.5	34	20	56	41	50	583	LE35LM	160	160	160
	42	M48 2	36	36	55	51	40.0	39	22	63	50	60	821	LE42LM	160	160	160
S ⁴⁾	20	M27 2	16	16	32	37	26.5	26	16	48	27	36	264	LE20SM	400	400	400
	25	M33 2	20	20	39	42	30.0	30	18	54	36	46	497	LE25SM	250	250	250
	30	M42 2	25	25	49	49	35.5	34	20	62	41	50	744	LE30SM	160	160	160
	38	M48 2	32	32	55	57	41.0	39	22	72	50	60	1111	LE38SM	160	160	160

¹⁾ Pressure shown = item deliverable

³⁾ L = light series; ⁴⁾ S = heavy series

$$\frac{\text{PN (bar)}}{10} = \text{PN (MPa)}$$

Delivery without nut and ring. Information on ordering complete fittings see page I7.

Order code suffixes		
Material	Suffix surface and material	Example
Steel, zinc plated, chrome ⁶ -free	CFX	LE20SMCFX
Steel, zinc yellow plated	A3CX	LE20SMA3CX
Stainless Steel	71X	LE20SM71X

*Please add the **suffixes** below according to the material/surface required.

LE-R Male stud run tee

EO 24° cone end / Male BSPP thread – metal sealing edge (ISO 1179)

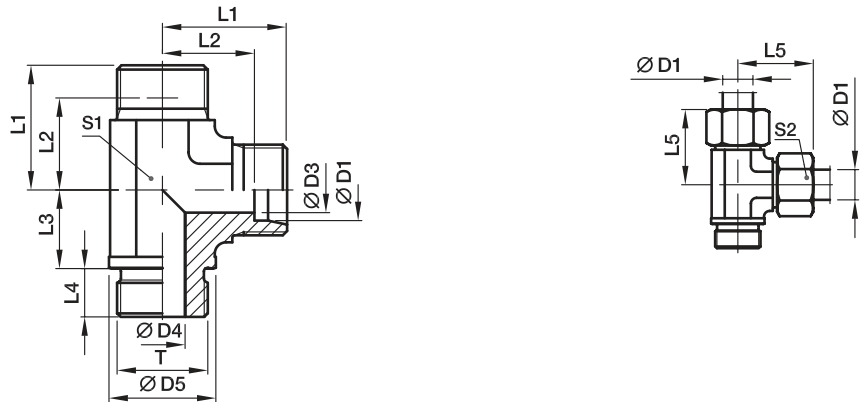

Series	D1	T	D3	D4	D5	L1	L2	L3	L4	L5	S1	S2	Weight g/1 piece	Order code*	PN (bar) ¹⁾		
															CF	A3C	71
L ³⁾	22	G3/4A	19	18	32	35	27.5	26	16	44	27	36	225	LE22LR	160	160	160
	28	G1A	24	23	39	38	30.5	30	18	47	36	41	358	LE28LR	160	160	160
	35	G1 1/4A	30	30	49	45	34.5	34	20	56	41	50	583	LE35LR	160	160	160
	42	G1 1/2A	36	36	55	51	40.0	39	22	63	50	60	821	LE42LR	160	160	160
S ⁴⁾	20	G3/4A	16	16	32	37	26.5	26	16	48	27	36	259	LE20SR	400	400	400
	25	G1A	20	20	39	42	30.0	30	18	54	36	46	495	LE25SR	250	250	250
	30	G1 1/4A	25	25	49	49	35.5	34	20	62	41	50	744	LE30SR	160	160	160
	38	G1 1/2A	32	32	55	57	41.0	39	22	72	50	60	1111	LE38SR	160	160	160

¹⁾ Pressure shown = item deliverable

³⁾ L = light series; ⁴⁾ S = heavy series

$\frac{\text{PN (bar)}}{10} = \text{PN (MPa)}$

Delivery without nut and ring. Information on ordering complete fittings see page I7.

Order code suffixes		
Material	Suffix surface and material	Example
Steel, zinc plated, chrome ⁶ -free	CFX	LE20SRCFX
Steel, zinc yellow plated	A3CX	LE20SRA3CX
Stainless Steel	71X	LE20SR71X

*Please add the **suffixes** below according to the material/surface required.

LE-R (KEG) Male stud run tee

EO 24° cone end / Male short BSP taper thread (DIN 3852-2, type C)

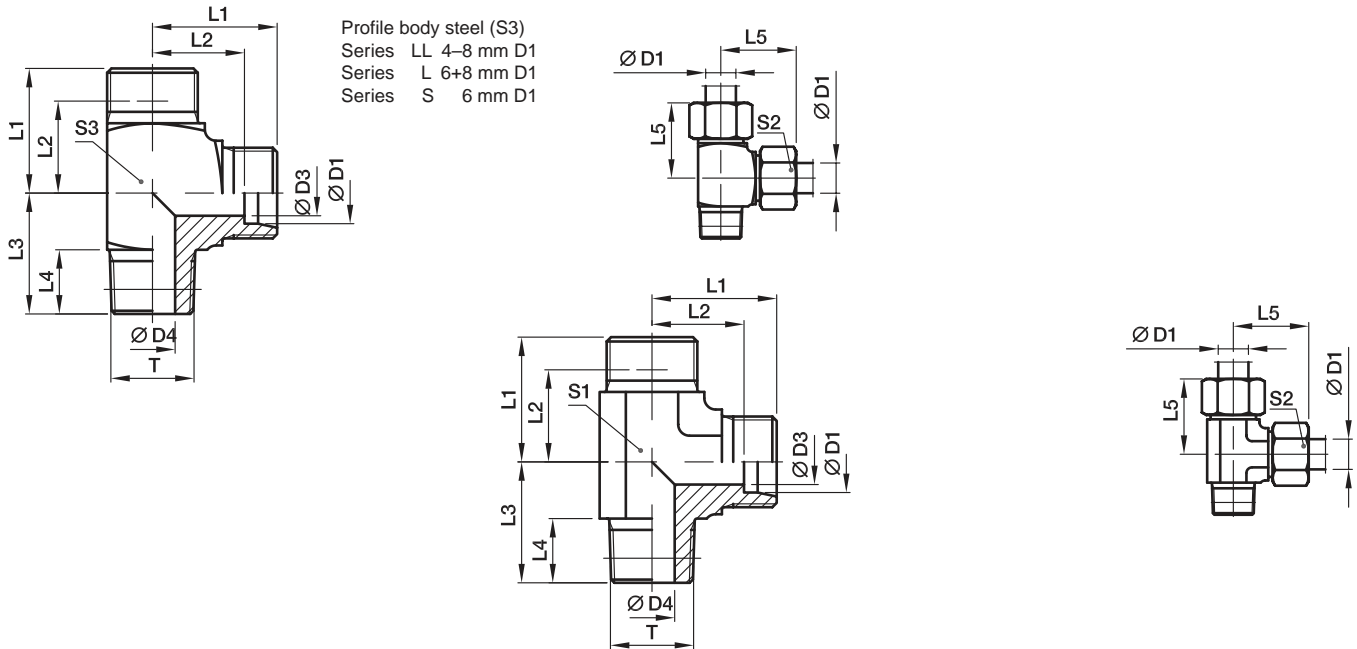

Series	D1	T	D3	D4	L1	L2	L3	L4	L5	S1	S2	S3	Weight g/1 piece	Order code*	PN (bar) ¹⁾		
															CF	A3C	71
LL ²⁾	04	R1/8tap.	3.0	4.0	15	11.0	17	8	21	9	10	11	20	LE04LLR	100	100	100
	06	R1/8tap.	4.5	4.5	15	9.5	17	8	21	9	12	11	21	LE06LLR	100	100	100
	08	R1/8tap.	6.0	6.0	17	11.5	20	8	23	12	14	12	28	LE08LLR	100	100	100
L ³⁾	06	R1/8tap.	4.0	4.0	19	12.0	20	8	27	12	14	12	40	LE06LR	315	315	315
	08	R1/4tap.	6.0	6.0	21	14.0	26	12	29	12	17	14	57	LE08LR	315	315	315
	10	R1/4tap.	8.0	7.0	22	15.0	27	12	30	14	19		50	LE10LR	315	315	315
	12	R3/8tap.	10.0	9.0	24	17.0	28	12	32	17	22		60	LE12LR	315	315	315
	15	R1/2tap.	12.0	11.0	28	21.0	34	14	36	19	27		115	LE15LR	315	315	315
	18	R1/2tap.	15.0	14.0	31	23.5	36	14	40	24	32		145	LE18LR	315	315	315
S ⁴⁾	06	R1/4tap.	4.0	4.0	23	16.0	26	12	31	12	17	14	71	LE06SR	400	400	400
	08	R1/4tap.	5.0	5.0	24	17.0	27	12	32	14	19		62	LE08SR	400	400	400
	10	R3/8tap.	7.0	7.0	25	17.5	28	12	34	17	22		82	LE10SR	400	400	400
	12	R3/8tap.	8.0	8.0	29	21.5	28	12	38	17	24		102	LE12SR	400	400	400
	14	R1/2tap.	10.0	10.0	30	22.0	32	14	40	19	27		130	LE14SR	400	400	400
	16	R1/2tap.	12.0	12.0	33	24.5	32	14	43	24	30		193	LE16SR	400	400	400

¹⁾ Pressure shown = item deliverable

²⁾ LL = very light series; ³⁾ L = light series; ⁴⁾ S = heavy series

$$\frac{\text{PN (bar)}}{10} = \text{PN (MPa)}$$

Delivery without nut and ring. Information on ordering complete fittings see page 17.

*Please add the **suffixes** below according to the material/surface required.

Order code suffixes		
Material	Suffix surface and material	Example
Steel, zinc plated, chrome ⁶ -free	CFX	LE16SRCFX
Steel, zinc yellow plated	A3CX	LE16SRA3CX
Stainless Steel	71X	LE16SR71X

LE-M(KEG) Male stud run tee

EO 24° cone end / Male short metric taper thread (DIN 3852-1, Form C)

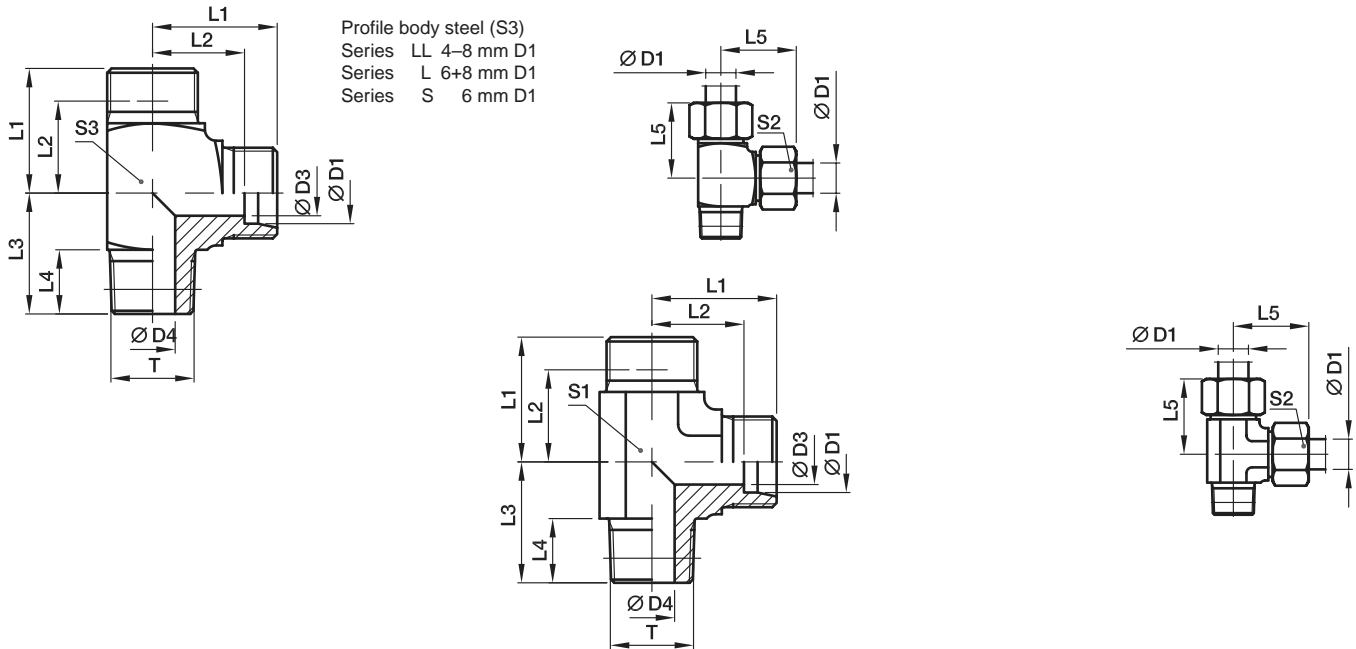

Series	D1	T	D3	D4	L1	L2	L3	L4	L5	S1	S2	S3	Weight g/1 piece	Order code*	PN (bar) ¹⁾		
															CF	A3C	71
LL ²⁾	04	M8 1tap.	3.0	3.5	15	11.0	17	8	21	9	10	9	17	LE04LLM	100	100	100
	06	M10 1tap.	4.5	4.5	15	9.5	17	8	21	9	12	11	21	LE06LLM	100	100	100
	08	M10 1tap.	6.0	6.0	17	11.5	20	8	23	12	14	12	29	LE08LLM	100	100	100
L ³⁾	06	M10 1tap.	4.0	4.0	19	12.0	20	8	27	12	14	12	38	LE06LM	315	315	315
	08	M12 1.5tap.	6.0	6.0	21	14.0	26	12	29	12	17	14	56	LE08LM	315	315	315
	10	M14 1.5tap.	8.0	7.0	22	15.0	27	12	30	14	19		47	LE10LM	315	315	315
	12	M16 1.5tap.	10.0	9.0	24	17.0	28	12	32	17	22		58	LE12LM	315	315	315
	15	M18 1.5tap.	12.0	11.0	28	21.0	32	12	36	19	27		98	LE15LM	315	315	315
	18	M22 1.5tap.	15.0	14.0	31	23.5	36	14	40	24	32		156	LE18LM	315	315	315
S ⁴⁾	06	M12 1.5tap.	4.0	4.0	23	16.0	26	12	31	12	17	14	70	LE06SM	400	400	400
	08	M14 1.5tap.	5.0	5.0	24	17.0	27	12	32	14	19		66	LE08SM	400	400	400
	10	M16 1.5tap.	7.0	7.0	25	17.5	28	12	34	17	22		123	LE10SM	400	400	400
	12	M18 1.5tap.	8.0	8.0	29	21.5	28	12	38	17	24		169	LE12SM	400	400	400
	14	M20 1.5tap.	10.0	10.0	30	22.0	32	14	40	19	27		174	LE14SM	400	400	400
	16	M22 1.5tap.	12.0	12.0	33	24.5	32	14	43	24	30		178	LE16SM	400	400	400

¹⁾ Pressure shown = item deliverable

²⁾ LL = very light series; ³⁾ L = light series; ⁴⁾ S = heavy series

$$\frac{\text{PN (bar)}}{10} = \text{PN (MPa)}$$

Delivery without nut and ring. Information on ordering complete fittings see page 17.

Order code suffixes		
Material	Suffix surface and material	Example
Steel, zinc plated, chrome ⁶ -free	CFX	LE16SMCFX
Steel, zinc yellow plated	A3CX	LE16SMA3CX
Stainless Steel	71X	LE16SM71X

*Please add the **suffixes** below according to the material/surface required.

GAI-M Female connector

Female metric thread (ISO 9974-1) / EO 24° cone end

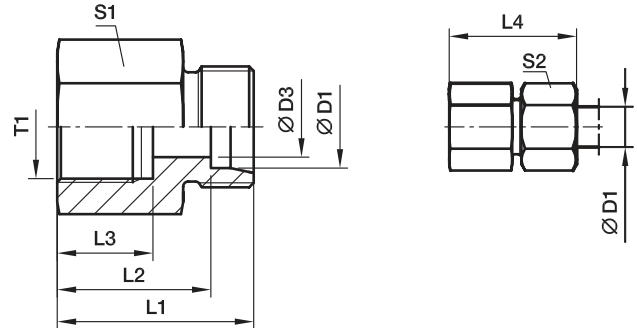

Series	D1	T1	D3	L1	L2	L3	L4	S1	S2	Weight g/1 piece	Order code*	PN (bar) ¹⁾		
												CF	A3C	71
L ³⁾	06	M10 1	4	26.5	19.5	12.5	34	14	14	18	GAI06LM	315	315	315
	08	M12 1.5	6	31.0	24.0	17.0	39	17	17	32	GAI08LM	315	315	315
	10	M14 1.5	8	32.0	25.0	17.0	40	19	19	39	GAI10LM	315	315	315
	12	M16 1.5	10	33.0	26.0	17.0	41	22	22	52	GAI12LM	315	315	315
	15	M18 1.5	12	35.0	28.0	17.0	43	24	27	68	GAI15LM	315	315	315
	18	M22 1.5	15	37.0	29.5	19.0	46	30	32	111	GAI18LM	315	315	315
	22	M26 1.5	19	42.0	34.5	21.0	51	32	36	123	GAI22LM	160	160	160
	28	M33 2	24	45.0	37.5	24.0	54	41	41	211	GAI28LM	160	160	160
	35	M42 2	30	51.0	40.5	26.0	62	55	50	459	GAI35LM	160	160	160
	42	M48 2	36	53.0	42.0	28.0	65	60	60	522	GAI42LM	160	160	160
S ⁴⁾	06	M12 1.5	4	33.0	26.0	17.0	41	17	17	35	GAI06SM	400	400	400
	08	M14 1.5	5	33.0	26.0	17.0	41	17	19	42	GAI08SM	400	400	400
	10	M16 1.5	7	34.0	26.5	17.0	43	22	22	58	GAI10SM	400	400	400
	12	M18 1.5	8	35.0	27.5	17.0	44	24	24	70	GAI12SM	400	400	400
	14	M20 1.5	10	39.0	31.0	19.0	49	27	27	95	GAI14SM	400	400	400
	16	M22 1.5	12	39.0	30.5	19.0	49	30	30	114	GAI16SM	400	400	400
	20	M27 2	16	45.0	34.5	22.0	56	36	36	189	GAI20SM	315	315	315
	25	M33 2	20	49.0	37.0	24.0	61	41	46	235	GAI25SM	315	315	315
	30	M42 2	25	55.0	41.5	26.0	68	55	50	490	GAI30SM	315	315	315
	38	M48 2	32	59.0	43.0	28.0	74	60	60	597	GAI38SM	250	250	250

1) Pressure shown = item deliverable

3) L = light series; 4) S = heavy series

$$\frac{\text{PN (bar)}}{10} = \text{PN (MPa)}$$

Delivery without nut and ring. Information on ordering complete fittings see page 17.

*Please add the **suffixes** below according to the material/surface required.

Order code suffixes		
Material	Suffix surface and material	Example
Steel, zinc plated, chrome ⁶ -free	CFX	GAI16SMCFX
Steel, zinc yellow plated	A3CX	GAI16SMA3CX
Stainless Steel	71X	GAI16SM71X

GAI-R Female connector

Female BSPP thread (ISO 1179-1) / EO 24° cone end

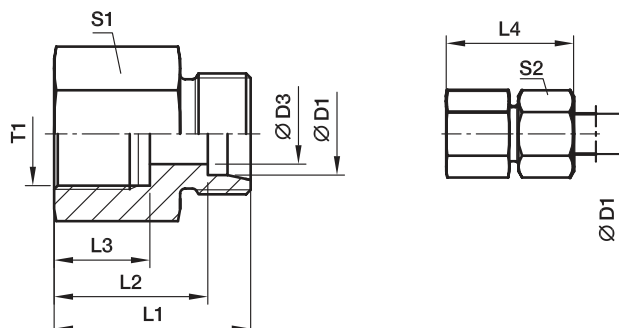

Series	D1	T1	D3	L1	L2	L3	L4	S1	S2	Weight g/1 piece	Order code*	PN (bar) ¹⁾			
												CF	A3C	71	MS
L ³⁾	06	G1/8	4	26.0	19.0	12.0	34	14	14	18	GAI06LR	315	315	315	200
	06	G1/4	4	31.0	24.0	17.0	39	19	14	39	GAI06LR1/4	315	315	315	200
	08	G1/4	6	31.0	24.0	17.0	39	19	17	39	GAI08LR	315	315	315	200
	08	G3/8	6	32.0	25.0	17.0	40	24	17	61	GAI08LR3/8	315	315	315	200
	08	G1/2	6	36.0	29.0	20.0	44	27	17	80	GAI08LR1/2	315	315	315	200
	10	G1/4	8	32.0	25.0	17.0	40	19	19	40	GAI10LR	315	315	315	200
	10	G3/8	8	33.0	26.0	17.0	41	24	19	63	GAI10LR3/8	315	315	315	200
	10	G1/2	8	37.0	30.0	20.0	45	27	19	81	GAI10LR1/2	315	315	315	200
	12	G3/8	10	33.0	26.0	17.0	41	24	22	64	GAI12LR	315	315	315	200
	12	G1/2	10	37.0	30.0	20.0	45	27	22	83	GAI12LR1/2	315	315	315	200
	15	G1/2	12	38.0	31.0	20.0	46	27	27	87	GAI15LR	315	315	315	200
	18	G1/2	15	38.0	30.5	20.0	47	27	32	89	GAI18LR	315	315	315	200
	18	G3/8	15	34.0	26.5	17.0	43	27	32	95	GAI18LR3/8	315	315	315	200
	22	G3/4	19	43.0	35.5	22.0	52	36	36	173	GAI22LR	160	160	160	100
	28	G1	24	45.5	38.0	24.5	55	41	41	211	GAI28LR	160	160	160	100
	35	G11/4	30	51.5	41.0	26.5	63	55	50	469	GAI35LR	160	160	160	100
	42	G11/2	36	53.5	42.5	28.5	65	60	60	540	GAI42LR	160	160	160	100
	S ⁴⁾	06	G1/4	4	33.0	26.0	17.0	41	19	17	43	GAI06SR	400	400	400
08		G1/4	5	33.0	26.0	17.0	41	19	19	47	GAI08SR	400	400	400	
10		G3/8	7	34.0	26.5	17.0	43	24	22	68	GAI10SR	400	400	400	
12		G3/8	8	34.0	26.5	17.0	43	24	24	71	GAI12SR	400	400	400	
12		G1/2	8	38.0	30.5	20.0	47	30	24	121	GAI12SR1/2	400	400	400	
14		G1/2	10	40.0	32.0	20.0	50	30	27	125	GAI14SR	400	400	400	
16		G1/2	12	40.0	31.5	20.0	50	30	30	126	GAI16SR	400	400	400	
20		G3/4	16	45.0	34.5	22.0	56	36	36	196	GAI20SR	315	315	315	
25		G1	20	49.5	37.5	24.5	62	41	46	246	GAI25SR	315	315	315	
30		G11/4	25	55.5	42.0	26.5	69	55	50	537	GAI30SR	315	315	315	
38		G11/2	32	59.5	43.5	28.5	74	60	60	649	GAI38SR	250	250	250	

¹⁾ Pressure shown = item deliverable

³⁾ L = light series; ⁴⁾ S = heavy series

$$\frac{\text{PN (bar)}}{10} = \text{PN (MPa)}$$

Delivery without nut and ring. Information on ordering complete fittings see page I7.

*Please add the **suffixes** below according to the material/surface required.

Order code suffixes		
Material	Suffix surface and material	Example
Steel, zinc plated, chrome ⁶ -free	CFX	GAI16SRCFX
Steel, zinc yellow plated	A3CX	GAI16SRA3CX
Stainless Steel	71X	GAI16SR71X
Brass	MSX	GAI16SRMSX

GAI-NPT Female connector

Female NPT thread (SAE 476) / EO 24° cone end

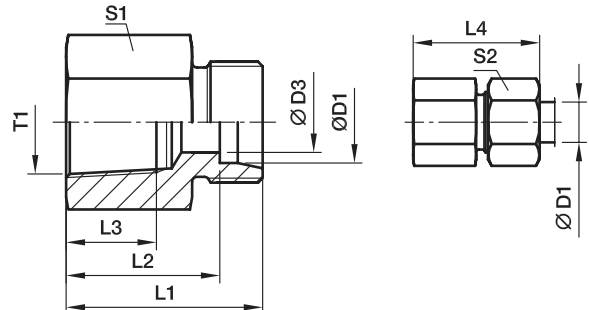

Series	D1	T1	D3	L1	L2	L3	L4	S1	S2	Weight g/1 piece	Order code*	PN (bar) ¹⁾		
												CF	A3C	71
L ³⁾	06	1/8-27NPT	4	26.0	19.0	11.6	34	14	14	19	GAI06L1/8NPT	315	315	315
	06	1/4-18NPT	4	30.5	23.5	16.4	38	19	14	38	GAI06L1/4NPT	315	315	315
	08	1/4-18NPT	6	30.5	23.5	16.4	38	19	17	39	GAI08L1/4NPT	315	315	315
	10	1/4-18NPT	8	31.0	24.0	16.4	39	19	19	40	GAI10L1/4NPT	315	315	315
	12	3/8-18NPT	10	34.0	27.0	17.4	42	24	22	69	GAI12L3/8NPT	315	315	315
	12	1/2-14NPT	10	39.0	32.0	22.6	47	27	22	91	GAI12L1/2NPT	315	315	315
	15	1/2-14NPT	12	40.0	33.0	22.6	48	27	27	96	GAI15L1/2NPT	315	315	315
	18	1/2-14NPT	15	40.0	32.5	22.6	49	27	32	99	GAI18L1/2NPT	315	315	315
	22	3/4-14NPT	19	43.0	35.5	23.1	52	36	36	184	GAI22L3/4NPT	160	160	160
	28	1-11 1/2NPT	24	48.0	40.5	27.8	57	41	41	238	GAI28L1NPT	160	160	160
	35	1 1/4-11 1/2NPT	30	51.0	40.5	28.3	62	55	50	424	GAI35L11/4NPT	160	160	160
	42	1 1/2-11 1/2NPT	36	53.0	42.0	28.3	65	60	60	547	GAI42L11/2NPT	160	160	160
S ⁴⁾	06	1/8-27NPT	4	29.0	22.0	11.6	36	14	17	25	GAI06S1/8NPT	400	400	400
	06	1/4-18NPT	4	33.0	26.0	16.4	41	19	17	41	GAI06S1/4NPT	400	400	400
	08	1/4-18NPT	5	33.0	26.0	16.4	41	19	19	42	GAI08S1/4NPT	400	400	400
	10	3/8-18NPT	7	35.0	27.0	17.4	44	24	22	74	GAI10S3/8NPT	400	400	400
	12	1/4-18NPT	8	32.5	25.0	16.4	41	22	24	81	GAI12S1/4NPT	400	400	400
	12	3/8-18NPT	8	35.0	27.5	17.4	44	24	24	76	GAI12S3/8NPT	400	400	400
	12	1/2-14NPT	8	41.0	33.5	22.6	50	27	24	101	GAI12S1/2NPT	400	400	400
	14	1/2-14NPT	10	43.0	35.0	22.6	53	27	27	108	GAI14S1/2NPT	400	400	400
	16	1/2-14NPT	12	43.0	34.5	22.6	50	27	30	111	GAI16S1/2NPT	400	400	400
	20	1/2-14NPT	16	44.0	33.5	22.6	55	32	36	129	GAI20S1/2NPT	315	315	315
	20	3/4-14NPT	16	46.0	35.5	23.1	57	36	36	214	GAI20S3/4NPT	315	315	315
	25	1-11 1/2NPT	20	53.0	41.0	27.8	65	41	46	288	GAI25S1NPT	315	315	315
	30	1 1/4-11 1/2NPT	25	57.0	43.5	28.3	70	55	50	559	GAI30S11/4NPT	315	315	315
	38	1 1/2-11 1/2NPT	32	59.0	43.0	28.3	74	60	60	632	GAI38S11/2NPT	250	250	250

1) Pressure shown = item deliverable

3) L = light series; 4) S = heavy series

$$\frac{PN(\text{bar})}{10} = PN(\text{MPa})$$

Delivery without nut and ring. Information on ordering complete fittings see page 17.

*Please add the **suffixes** below according to the material/surface required.

Order code suffixes		
Material	Suffix surface and material	Example
Steel, zinc plated, chrome ⁶ -free	CFX	GAI16S1/2NPTCFX
Steel, zinc yellow plated	A3CX	GAI16S1/2NPTA3CX
Stainless Steel	71X	GAI16S1/2NPT71X

RI-ED Thread reducer/expander

Male BSPP thread – ED-seal (ISO 1179) / Female BSPP thread (ISO 1179-1)

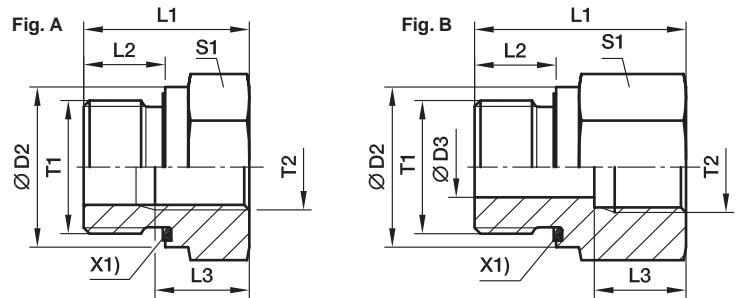

X1) Elastic-sealing ED

Male Stud T1	Female Stud T2	D2	D3	L1	L2	L3	S1	Fig.	Weight g/1 piece	Order code*	PN (bar) ¹⁾		
											CF	A3C	71
G 1/8 A	G 1/4	14	4	31.0	8	17.0	19	B	41	R11/8EDX1/4	400	400	400
G 1/8 A	G 3/8	14	4	32.0	8	17.0	24	B	63	R11/8EDX3/8	400	400	400
G 1/4 A	G 1/8	19	5	29.0	12	12.0	19	B	41	R11/4EDX1/8	400	400	400
G 1/4 A	G 3/8	19	5	36.0	12	17.0	24	B	69	R11/4EDX3/8	400	400	400
G 1/4 A	G 1/2	19	5	40.0	12	20.0	30	B	120	R11/4EDX1/2	400	400	400
G 1/4 A	G 3/4	19	5	43.0	12	22.0	36	B	171	R11/4EDX3/4	400	400	400
G 3/8 A	G 1/8	22		22.5	12	8.0	22	A	38	R13/8EDX1/8	400	400	400
G 3/8 A	G 1/4	22	8	36.0	12	17.0	22	B	68	R13/8EDX1/4	400	400	400
G 3/8 A	G 1/2	22	8	41.0	12	20.0	30	B	124	R13/8EDX1/2	400	400	400
G 3/8 A	G 3/4	22	8	44.0	12	22.0	36	B	182	R13/8EDX3/4	315	315	315
G 1/2 A	G 1/8	27		24.0	14	8.0	27	A	65	R11/2EDX1/8	400	400	400
G 1/2 A	G 1/4	27		24.0	14	12.0	27	A	56	R11/2EDX1/4	400	400	400
G 1/2 A	G 3/8	27	12	37.0	14	17.0	27	B	95	R11/2EDX3/8	400	400	400
G 1/2 A	G 3/4	27	12	46.0	14	22.0	36	B	183	R11/2EDX3/4	315	315	315
G 1/2 A	G 1	27	12	49.0	14	24.5	41	B	232	R11/2EDX1	315	315	315
G 1/2 A	G 1 1/4	27	10	53.0	14	26.5	55	B	481	R11/2EDX11/4	315	315	315
G 3/4 A	G 1/4	32		26.0	16	12.0	32	A	103	R13/4EDX1/4	315	315	315
G 3/4 A	G 3/8	32		26.0	16	12.0	32	A	86	R13/4EDX3/8	315	315	315
G 3/4 A	G 1/2	32	16	43.0	16	20.0	32	B	156	R13/4EDX1/2	315	315	315
G 3/4 A	G 1	32	16	51.0	16	24.5	41	B	237	R13/4EDX1	315	315	315
G 3/4 A	G 1 1/4	32	16	55.0	16	26.5	55	B	486	R13/4EDX11/4	315	315	315
G 3/4 A	G 1 1/2	32	16	57.0	16	28.5	60	B	561	R13/4EDX11/2	250	250	250
G 1 A	G 1/4	40		29.0	18	12.0	41	A	197	R11EDX1/4	315	315	315
G 1 A	G 3/8	40		29.0	18	12.0	41	A	179	R11EDX3/8	315	315	315
G 1 A	G 1/2	40		29.0	18	14.0	41	A	153	R11EDX1/2	315	315	315
G 1 A	G 3/4	40	20	49.0	18	22.0	41	B	290	R11EDX3/4	315	315	315
G 1 A	G 1 1/4	40	20	57.0	18	26.5	55	B	503	R11EDX11/4	315	315	315
G 1 A	G 1 1/2	40	20	59.0	18	28.5	60	B	585	R11EDX11/2	250	250	250
G 1 1/4 A	G 1/2	50		32.0	20	14.0	50	A	313	R111/4EDX1/2	315	315	315
G 1 1/4 A	G 3/4	50		32.0	20	16.0	50	A	393	R111/4EDX3/4	315	315	315
G 1 1/4 A	G 1	50	25	5.0	20	24.5	50	B	469	R111/4EDX1	315	315	315
G 1 1/4 A	G 1 1/2	50	25	60.0	20	28.5	60	B	624	R111/4EDX11/2	250	250	250
G 1 1/2 A	G 1/2	55		36.0	22	14.0	55	A	470	R111/2EDX1/2	250	250	250
G 1 1/2 A	G 3/4	55		36.0	22	16.0	55	A	415	R111/2EDX3/4	250	250	250
G 1 1/2 A	G 1	55		36.0	22	18.0	55	A	338	R111/2EDX1	250	250	250
G 1 1/2 A	G 1 1/4	55	32	58.0	22	26.5	55	B	542	R111/2EDX11/4	250	250	250
G 2 A	G 1 1/2	75	40	65.0	24	28.5	75	B	1309	R12EDX11/2	160	160	

¹⁾ Pressure shown = item deliverable

$$\frac{\text{PN (bar)}}{10} = \text{PN (MPa)}$$

Information on ordering alternative sealing materials see page 17.

*Please add the suffixes below according to the material/surface required.

Order code suffixes			
Material	Suffix surface and material	Example	Standard sealing material (no additional suffix needed)
Steel, zinc plated, chrome ²⁾ -free	CF	R11EDX1/2CF	NBR
Steel, zinc yellow plated	A3C	R11EDX1/2A3C	NBR
Stainless Steel	71	R11EDX1/271	VIT

RI Thread reducer/expander

Male BSPP thread – metal sealing edge (ISO 1179) / Female BSPP thread (ISO 1179-1)

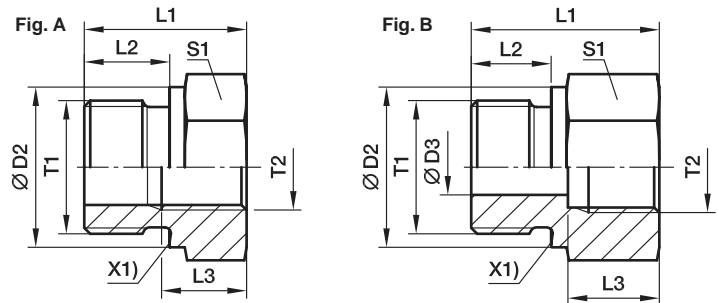

X1) metal sealing edge

Male Stud T1	Male Stud T2	D2	D3	L1	L2	L3	S1	Fig.	Weight g/1 piece	Order code*	PN (bar) ¹⁾			
											CF	A3C	71	MS
G 1/8 A	G 1/4	14	4	31.0	8	17.0	19	B	42	R11/8X1/4	400	400	400	250
G 1/8 A	G 3/8	14	4	32.0	8	17.0	24	B	63	R11/8X3/8	400	400	400	250
G 1/4 A	G 1/8	18	5	28.0	12	12.0	19	B	38	R11/4X1/8	400	400	400	250
G 1/4 A	G 3/8	18	5	36.0	12	17.0	24	B	69	R11/4X3/8	400	400	400	250
G 1/4A	G 1/2	18	5	40.0	12	20.0	30	B	116	R11/4X1/2	400	400	400	250
G 1/4 A	G 3/4	18	5	43.0	12	22.0	36	B	170	R11/4X3/4	315	315	315	200
G 3/8 A	G 1/8	22		22.5	12	8.0	22	A	39	R13/8X1/8	400	400	400	250
G 3/8 A	G 1/4	22	8	36.0	12	17.0	22	B	68	R13/8X1/4	400	400	400	250
G 3/8 A	G 1/2	22	8	41.0	12	20.0	30	B	125	R13/8X1/2	400	400	400	250
G 3/8 A	G 3/4	22	8	44.0	12	22.0	36	B	183	R13/8X3/4	315	315	315	200
G 1/2 A	G 1/8	26		24.0	14	8.0	27	A	66	R11/2X1/8	400	400	400	250
G 1/2 A	G 1/4	26		24.0	14	12.0	27	A	56	R11/2X1/4	315	315	315	200
G 1/2 A	G 3/8	26	12	36.0	14	17.0	27	B	94	R11/2X3/8	315	315	315	200
G 1/2 A	G 3/4	26	12	46.0	14	22.0	36	B	182	R11/2X3/4	315	315	315	200
G 1/2 A	G 1	26	12	49.0	14	24.5	41	B	221	R11/2X1	315	315	315	200
G 1/2 A	G 1 1/4	26	10	53.0	14	26.5	55	B	482	R11/2X11/4	160	160	160	
G 3/4 A	G 1/4	32		26.0	16	12.0	32	A	103	R13/4X1/4	315	315	315	200
G 3/4 A	G 3/8	32		26.0	16	12.0	32	A	87	R13/4X3/8	315	315	315	200
G 3/4 A	G 1/2	32	16	41.0	16	20.0	32	B	143	R13/4X1/2	315	315	315	200
G 3/4 A	G 1	32	16	51.0	16	24.5	41	B	235	R13/4X1	315	315	315	200
G 3/4 A	G 1 1/4	32	16	55.0	16	26.5	55	B	481	R13/4X11/4	160	160	160	
G 3/4 A	G 1 1/2	32	16	57.0	16	28.5	60	B	560	R13/4X11/2	160	160	160	
G 1 A	G 1/4	39		29.0	18	12.0	41	A	195	R11X1/4	315	315	315	
G 1 A	G 3/8	39		29.0	18	12.0	41	A	179	R11X3/8	315	315	315	200
G 1 A	G 1/2	39		29.0	18	14.0	41	A	157	R11X1/2	315	315	315	200
G 1 A	G 3/4	39	20	47.0	18	22.0	41	B	278	R11X3/4	315	315	315	200
G 1 A	G 1 1/4	39	20	57.0	18	26.5	55	B	530	R11X11/4	160	160	160	100
G 1 A	G 1 1/2	39	20	59.0	18	28.5	60	B	585	R11X11/2	160	160	160	100
G 1 1/4 A	G 1/2	49		32.0	20	14.0	50	A	308	R111/4X1/2	160	160	160	100
G 1 1/4 A	G 3/4	49		32.0	20	16.0	50	A	267	R111/4X3/4	160	160	160	100
G 1 1/4 A	G 1	49	25	52.0	20	24.5	50	B	458	R111/4X1	160	160	160	100
G 1 1/4 A	G 1 1/2	49	25	60.0	20	28.5	60	B	616	R111/4X11/2	160	160	160	100
G 1 1/2 A	G 1/2	55		36.0	22	14.0	55	A	477	R111/2X1/2	160	160	160	100
G 1 1/2 A	G 3/4	55		36.0	22	16.0	55	A	402	R111/2X3/4	160	160	160	100
G 1 1/2 A	G 1	55		36.0	22	18.0	55	A	337	R111/2X1	160	160	160	100
G 1 1/2 A	G 1 1/4	55	32	58.0	22	26.5	55	B	542	R111/2X11/4	160	160	160	100
G 2 A	G 1 1/2	68	40	62.0	24	28.5	70	B	990	R12X11/2	160	160		

¹⁾ Pressure shown = item deliverable

$$\frac{\text{PN (bar)}}{10} = \text{PN (MPa)}$$

*Please add the **suffixes** below according to the material/surface required.

Order code suffixes		
Material	Suffix surface and material	Example
Steel, zinc plated, chrome ⁶ -free	CFX	R11X1/2CFX
Steel, zinc yellow plated	A3CX	R11X1/2A3CX
Stainless Steel	71X	R11X1/271X
Brass	MSX	R11X1/2MSX

MAV Pressure gauge connector

Female BSPP thread / EO 24° cone end

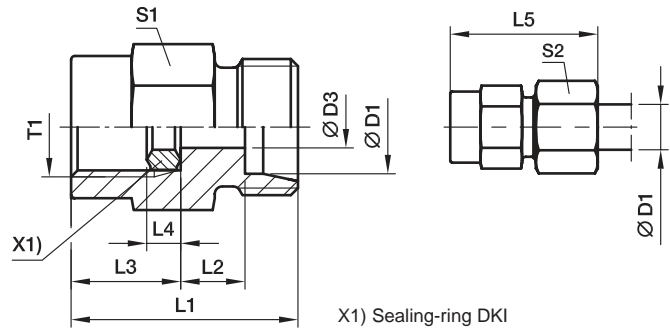

Series	D1 	T1	D3	L1	L2	L3	L4	L5	S1	S2	Weight g/1 piece	Order code*	PN (bar) ¹⁾			
													CF	A3C	71	MS
LL ²⁾	04	G1/4	2.5	27	8.5	14.5	4.5	33	19	10	33	MAV04LLROMD	100	100		
L ³⁾	06	G1/4	2.5	29	7.5	14.5	4.5	37	19	14	37	MAV06LROMD	315	315	315	315
	08	G1/4	5.5	29	7.5	14.5	4.5	37	19	17	38	MAV08LROMD	315	315	315	315
	10	G1/4	5.5	30	8.5	14.5	4.5	38	19	19	41	MAV10LROMD	315	315	315	315
	12	G1/4	5.5	30	8.5	14.5	4.5	38	19	22	43	MAV12LROMD	315	315	315	315
S ⁴⁾	06	G1/2	3.5	38	11.0	20.0	5.0	46	27	17	86	MAV06SROMD	630	630	630	630
	08	G1/2	3.5	38	11.0	20.0	5.0	46	27	19	86	MAV08SROMD	630	630	630	630
	10	G1/2	7.5	38	10.5	20.0	5.0	47	27	22	88	MAV10SROMD	630	630	630	630
	12	G1/2	7.5	38	10.5	20.0	5.0	47	27	24	93	MAV12SROMD	630	630	630	630

¹⁾ Pressure shown = item deliverable

²⁾ LL = very light series; ³⁾ L = light series; ⁴⁾ S = heavy series

$$\frac{\text{PN (bar)}}{10} = \text{PN (MPa)}$$

Delivery without nut and ring. Information on ordering complete fittings see page I7.

Order code suffixes		
Material	Suffix surface and material	Example
Steel, zinc plated, chrome ⁶ -free	CF	MAV10SROMDCF
Steel, zinc yellow plated	A3C	MAV10SROMDA3C
Stainless Steel	71	MAV10SROMD71
Brass	MS	MAV10SROMDMS

*Please add the **suffixes** below according to the material/surface required.

MAVE Pressure gauge swivel connector

Female BSPP thread / EO 24° DKO swivel

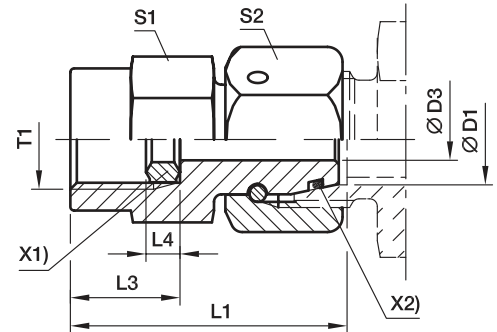

X1) Sealing-ring DK1
X2) O-ring OR

Series	D1	T1	D3	L1	L3	L4	S1	S2	Weight g/1 piece	Order code*	PN (bar) ¹⁾		
											CF	A3C	71
L ³⁾	06	G1/4	2.5	35.5	14.5	4.5	19	14	46	MAVE06LR	315	315	315
	08	G1/4	4.0	35.5	14.5	4.5	19	17	52	MAVE08LR	315	315	315
	10	G1/4	5.5	36.0	14.5	4.5	19	19	59	MAVE10LR	315	315	315
	12	G1/4	5.5	36.0	14.5	4.5	19	22	70	MAVE12LR	315	315	315
S ⁴⁾	06	G1/2	2.5	42.5	20.0	5.0	27	17	95	MAVE06SR	630	630	630
	06	G1/4	2.5	35.5	14.5	4.5	19	17	52	MAVE06SR1/4	630	630	630
	08	G1/2	4.0	43.0	20.0	5.0	27	19	100	MAVE08SR	630	630	630
	08	G1/4	4.0	35.5	14.5	4.5	19	19	58	MAVE08SR1/4	630	630	630
	10	G1/2	6.0	43.5	20.0	5.0	27	22	109	MAVE10SR	630	630	630
	10	G1/4	7.0	39.0	14.5	4.5	19	22	67	MAVE10SR1/4	630	630	630
	12	G1/2	7.0	45.0	20.0	5.0	27	24	125	MAVE12SR	630	630	630
	12	G1/4	7.0	39.0	14.5	4.5	19	24	83	MAVE12SR1/4	630	630	630

¹⁾ Pressure shown = item deliverable

³⁾ L = light series; ⁴⁾ S = heavy series

$$\frac{\text{PN (bar)}}{10} = \text{PN (MPa)}$$

Information on ordering alternative sealing materials see page 17.

*Please add the **suffixes** below according to the material/surface required.

Order code suffixes			
Material	Suffix surface and material	Example	Standard sealing material (no additional suffix needed)
Steel, zinc plated, chrome ⁶ -free	CF	MAVE10SRCF	NBR
Steel, zinc yellow plated	A3C	MAVE10SRA3C	NBR
Stainless Steel	71	MAVE10SR71	VIT

ROV Blanking plug for tube ends

EO 24° cone end

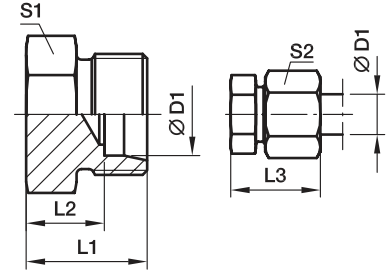

Series	D1 	L1	L2	L3	S1	S2	Weight g/1 piece	Order code*	PN (bar) ¹⁾			
									CF	A3C	71	
L ³⁾	06	14	7.0	22	12	14	8	ROV06L	315	315	315	
	08	15	8.0	23	14	17	13	ROV08L	315	315	315	
	10	16	9.0	24	17	19	17	ROV10L	315	315	315	
	12	17	10.0	25	19	22	24	ROV12L	315	315	315	
	15	18	11.0	26	24	27	41	ROV15L	315	315	315	
	18	19	11.5	28	27	32	56	ROV18L	315	315	315	
	22	21	13.5	30	32	36	84	ROV22L	160	160	160	
	28	22	14.5	31	41	41	138	ROV28L	160	160	160	
	35	25	14.5	36	46	50	203	ROV35L	160	160	160	
	42	27	16.0	39	55	60	318	ROV42L	160	160	160	
	S ⁴⁾	06	18	11.0	26	14	17	17	ROV06S	630	630	630
		08	20	13.0	28	17	19	28	ROV08S	630	630	630
10		20	12.5	29	19	22	33	ROV10S	630	630	630	
12		22	14.5	31	22	24	50	ROV12S	630	630	630	
14		24	16.0	34	24	27	62	ROV14S	630	630	630	
16		24	15.5	34	27	30	75	ROV16S	400	400	400	
20		28	17.5	39	32	36	125	ROV20S	400	400	400	
25		32	20.0	44	41	46	229	ROV25S	400	400	400	
30		34	20.5	47	46	50	310	ROV30S	400	400	400	
38		39	23.0	54	55	60	508	ROV38S	315	315	315	

¹⁾ Pressure shown = item deliverable

³⁾ L = light series; ⁴⁾ S = heavy series

$\frac{\text{PN (bar)}}{10} = \text{PN (MPa)}$

Delivery without nut and ring. Information on ordering complete fittings see page 17.

*Please add the **suffixes** below according to the material/surface required.

Order code suffixes		
Material	Suffix surface and material	Example
Steel, zinc plated, chrome ⁶ -free	CFX	ROV16SCFX
Steel, zinc yellow plated	A3CX	ROV16SA3CX
Stainless Steel	71X	ROV16S71X

VSTI M-OR Blanking plug for ports

Male metric thread – O-ring (ISO 6149)

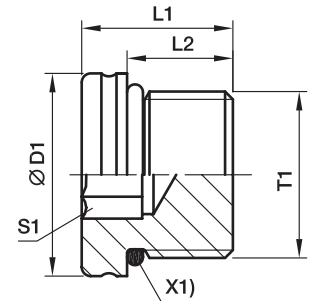

X1) O-ring OR

T1	D1	L1	L2	S1	Weight g/1 piece	Order code*	PN (bar) ¹⁾	
							CF	A3C
M8 1	12	13.0	9.5	4	6	VSTI8X1OR	630	630
M10 1	13	13.5	9.5	5	8	VSTI10X1OR	630	630
M12 1.5	17	16.0	11.0	6	14	VSTI12X1.5OR	630	630
M14 1.5	19	16.0	11.0	6	20	VSTI14X1.5OR	630	630
M16 1.5	21	17.5	12.5	8	26	VSTI16X1.5OR	630	630
M18 1.5	23	19.0	14.0	8	37	VSTI18X1.5OR	630	630
M22 1.5	27	20.0	15.0	10	58	VSTI22X1.5OR	630	630
M26 1.5	31	21.0	16.0	12	77	VSTI26X1.5OR	400	400
M27 2	32	23.5	18.5	12	95	VSTI27X2OR	400	400
M33 2	38	25.0	18.5	14	148	VSTI33X2OR	400	400
M42 2	48	25.5	19.0	22	233	VSTI42X2OR	400	400
M48 2	55	28.0	21.5	24	336	VSTI48X2OR	400	400

¹⁾ Pressure shown = item deliverable

$$\frac{\text{PN (bar)}}{10} = \text{PN (MPa)}$$

Information on ordering alternative sealing materials see page 17.

*Please add the **suffixes** below according to the material/surface required.

Order code suffixes			
Material	Suffix surface and material	Example	Standard sealing material (no additional suffix needed)
Steel, zinc plated, chrome ⁶ -free	CF	VSTI18X1.5ORCF	NBR
Steel, zinc yellow plated	A3C	VSTI18X1.5ORA3C	NBR

VSTI M/R-ED Blanking plug for ports

Male metric thread – ED-seal (ISO 9974)

Male BSPP thread – ED-seal (ISO 1179)

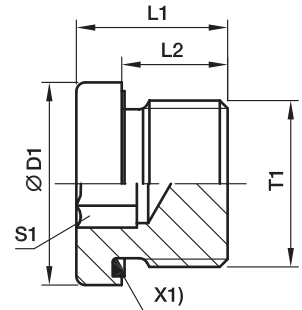

X1) Eolastic-sealing ED

Male metric parallel thread T1	Male stud BSP thread T1	D1	L1	L2	S1	Weight g/1 piece	Order code*	Order code*	PN (bar) ¹⁾					
									CF	A3C	71			
M 10 1	G 1/8 A	14.0	12.0	8	5	8	VSTI10X1ED	VSTI1/8ED	400	400	400			
M 12 1.5		17.0	17.0	12	6	14	VSTI12X1.5ED		400	400	400			
M 14 1.5		G 1/4 A	19.0	17.0	12	6	20		VSTI14X1.5ED	VSTI1/4ED	400	400	400	
M 16 1.5			G 3/8 A	22.0	17.0	12	8		25	VSTI16X1.5ED	VSTI3/8ED	400	400	400
M 18 1.5				23.9	17.0	12	8		32	VSTI18X1.5ED		400	400	400
M 20 1.5	25.9	19.0	14	10	42	VSTI20X1.5ED	400	400	400					
M 22 1.5	G 1/2 A	27.0	19.0	14	10	51	VSTI22X1.5ED	VSTI1/2ED	400	400	400			
M 26 1.5		31.9	21.0	16	12	78	VSTI26X1.5ED		400	400	400			
M 27 2	G 3/4 A	32.0	21.0	16	12	79	VSTI27X2ED	VSTI3/4ED	400	400	400			
M 33 2		G 1 A	39.9	22.5	16	17	130		VSTI33X2ED	VSTI1ED	400	400	400	
M 42 2	G 1 1/4 A		49.9	22.5	16	22	198	VSTI42X2ED	VSTI11/4ED	315	315	315		
M 48 2		G 1 1/2 A	55.0	22.5	16	24	263	VSTI48X2ED		VSTI11/2ED	315	315	315	

¹⁾ Pressure shown = item deliverable

$$\frac{\text{PN (bar)}}{10} = \text{PN (MPa)}$$

Information on ordering alternative sealing materials see page 17.

*Please add the **suffixes** below according to the material/surface required.

Order code suffixes			
Material	Suffix surface and material	Example	Standard sealing material (no additional suffix needed)
Steel, zinc plated, chrome ⁶ -free	CF	VSTI1/2EDCF	NBR
Steel, zinc yellow plated	A3C	VSTI1/2EDA3C	NBR
Stainless Steel	71	VSTI1/2ED71	VIT

VKA Blanking plug for cones

EO 24° DKO swivel

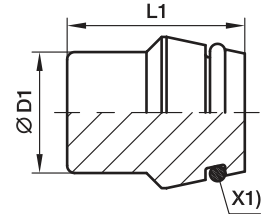

X1) O-ring OR

Series	D1 	L1	Weight g/1 piece	Order code*	PN (bar) ¹⁾			
					CF	A3C	71	MS
L ³⁾	06	18.5	6	VKA06	500	315	315	200
	08	18.5	9	VKA08	500	315	315	200
	10	20.0	15	VKA10	500	315	315	200
	12	20.5	21	VKA12	400	315	315	200
	15	20.5	32	VKA15	400	315	315	200
	18	22.5	49	VKA18	400	315	315	200
	22	25.0	80	VKA22	250	160	160	100
	28	25.5	131	VKA28	250	160	160	100
	35	30.0	240	VKA35	250	160	160	100
	42	30.0	343	VKA42	250	160	160	100
S ⁴⁾	06	18.5	6	VKA06	800	630	630	400
	08	18.5	9	VKA08	800	630	630	400
	10	20.0	15	VKA10	800	630	630	400
	12	20.5	21	VKA12	630	630	630	400
	14	22.5	30	VKA14	630	630	630	400
	16	23.5	40	VKA16	630	400	400	250
	20	28.5	78	VKA20	420	400	400	250
	25	29.0	120	VKA25	420	400	400	250
	30	30.5	180	VKA30	420	400	400	250
	38	33.0	309	VKA38	420	315	315	200

1) Pressure shown = item deliverable

3) L = light series; 4) S = heavy series

$$\frac{\text{PN (bar)}}{10} = \text{PN (MPa)}$$

Information on ordering alternative sealing materials see page 17.

*Please add the **suffixes** below according

Order code suffixes			
Material	Suffix surface and material	Example	Standard sealing material (no additional suffix needed)
Steel, zinc plated, chrome ⁶ -free	CF	VKA16CF	NBR
Steel, zinc yellow plated	A3C	VKA16A3C	NBR
Stainless Steel	71	VKA1671	VIT
Brass	MS	VKA16MS	NBR

VKAM Blanking plug with nut for cone

EO 24° DKO swivel

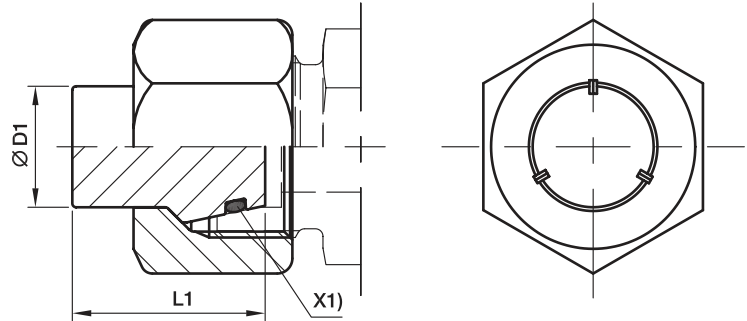

X1) O-ring OR

Series	D1 	L1	Weight g/1 piece	Order code*	PN (bar) ¹⁾		
					CF	A3C	71
L ³⁾	06	18.5	15	VKAM06L	500	315	315
	08	18.5	24	VKAM08L	500	315	315
	10	20.0	33	VKAM10L	500	315	315
	12	20.5	46	VKAM12L	400	315	315
	15	20.5	73	VKAM15L	400	315	315
	18	22.5	111	VKAM18L	400	315	315
	22	25.0	162	VKAM22L	250	160	160
	28	25.5	220	VKAM28L	250	160	160
	35	30.0	376	VKAM35L	250	160	160
	42	30.0	558	VKAM42L	250	160	160
S ⁴⁾	06	18.5	23	VKAM06S	800	630	630
	08	18.5	29	VKAM08S	800	630	630
	10	20.0	46	VKAM10S	800	630	630
	12	20.5	55	VKAM12S	630	630	630
	14	22.5	83	VKAM14S	630	630	630
	16	23.5	106	VKAM16S	630	400	400
	20	28.5	180	VKAM20S	420	400	400
	25	29.0	322	VKAM25S	420	400	400
	30	30.5	398	VKAM30S	420	400	400
	38	33.0	647	VKAM38S	420	315	315

1) Pressure shown = item deliverable

3) L = light series; 4) S = heavy series

$$\frac{\text{PN (bar)}}{10} = \text{PN (MPa)}$$

Information on ordering alternative sealing materials see page 17.

Order code suffixes			
Material	Suffix surface and material	Example	Standard sealing material (no additional suffix needed)
Steel, zinc plated, chrome ⁶ -free	CF	VKAM16SCF	NBR
Steel, zinc yellow plated	A3C	VKAM16SA3C	NBR
Stainless Steel	71	VKAM16S71	VIT

 *Please add the **suffixes** below according to the material/surface required.

BUZ Blanking plug for cones

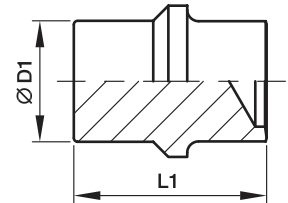

Series	D1 	L1	Weight g/1 piece	Order code*	PN (bar) ¹⁾			
					CF	A3C	71	MS
L ³⁾	06	19.5	5	BUZ06L	315	315	315	200
	08	19.5	8	BUZ08L	315	315	315	200
	10	21.0	13	BUZ10L	315	315	315	200
	12	21.8	20	BUZ12L	315	315	315	200
	15	22.0	30	BUZ15L	315	315	315	200
	18	24.0	45	BUZ18L	315	315	315	200
	22	26.0	74	BUZ22L	160	160	160	100
	28	26.5	117	BUZ28L	160	160	160	100
	35	32.0	217	BUZ35L	160	160	160	100
	42	32.5	308	BUZ42L	160	160	160	100
S ⁴⁾	06	19.5	5	BUZ06S	630	630	630	400
	08	19.5	8	BUZ08S	630	630	630	400
	10	21.0	13	BUZ10S	630	630	630	400
	12	21.8	20	BUZ12S	630	630	630	400
	14	23.5	28	BUZ14S	630	630	630	400
	16	25.5	39	BUZ16S	400	400	400	250
	20	30.5	73	BUZ20S	400	400	400	250
	25	32.5	119	BUZ25S	400	400	400	250
	30	35.5	181	BUZ30S	400	400	400	250
	38	40.0	325	BUZ38S	315	315	315	200

¹⁾ Pressure shown = item deliverable

³⁾ L = light series; ⁴⁾ S = heavy series

$\frac{PN \text{ (bar)}}{10} = PN \text{ (MPa)}$

*Please add the **suffixes** below according to the material/surface required.

Order code suffixes		
Material	Suffix surface and material	Example
Steel, zinc plated, chrome ⁶ -free	CFX	BUZ16SCFX
Steel, zinc yellow plated	A3CX	BUZ16SA3CX
Stainless Steel	71X	BUZ16S71X
Brass	MSX	BUZ16SMSX

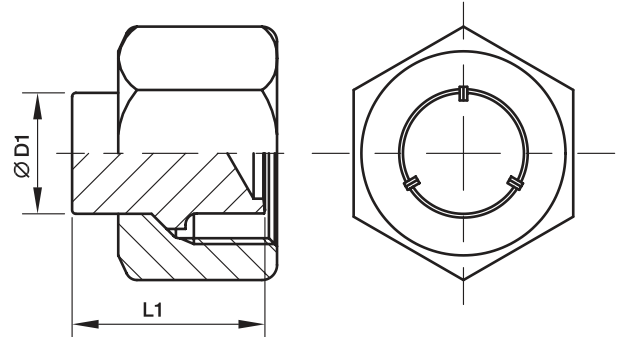
BUZM Blanking plug with nut for cones

Series	D1 	L1	Weight g/1 piece	Order code*	PN (bar) ¹⁾		
					CF	A3C	71
L ³⁾	06	19.5	15	BUZM06L	315	315	315
	08	19.5	23	BUZM08L	315	315	315
	10	21.0	31	BUZM10L	315	315	315
	12	21.8	45	BUZM12L	315	315	315
	15	22.0	71	BUZM15L	315	315	315
	18	24.0	107	BUZM18L	315	315	315
	22	26.0	156	BUZM22L	160	160	160
	28	26.5	206	BUZM28L	160	160	160
	35	32.0	354	BUZM35L	160	160	160
	42	32.5	524	BUZM42L	160	160	160
S ⁴⁾	06	19.5	23	BUZM06S	630	630	630
	08	19.5	28	BUZM08S	630	630	630
	10	21.0	44	BUZM10S	630	630	630
	12	21.8	54	BUZM12S	630	630	630
	14	23.5	81	BUZM14S	630	630	630
	16	25.5	105	BUZM16S	400	400	400
	20	30.5	176	BUZM20S	400	400	400
	25	32.5	321	BUZM25S	400	400	400
	30	35.5	399	BUZM30S	400	400	400
	38	40.0	664	BUZM38S	315	315	315

¹⁾ Pressure shown = item deliverable

³⁾ L = light series; ⁴⁾ S = heavy series

$\frac{\text{PN (bar)}}{10} = \text{PN (MPa)}$

*Please add the **suffixes** below according to the material/surface required.

Order code suffixes		
Material	Suffix surface and material	Example
Steel, zinc plated, chrome ⁶ -free	CF	BUZM16SCF
Steel, zinc yellow plated	A3C	BUZM16SA3C
Stainless Steel	71	BUZM16S71

GM Locknut for bulk heads

For bulkhead SV and WSV

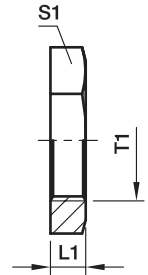

Series	Tube O.D.	T1	L1	S1	Weight g/1 piece	Order code				
						Steel CF	Steel A3C	Stainless Steel 71	Brass MS	
L ³⁾	06	M 12 1.5	6	17	7	GM06LCFX	GM06LA3CX	GM06L71X	GM06LMSX	
	08	M 14 1.5	6	19	8	GM08LCFX	GM08LA3CX	GM08L71X	GM08LMSX	
	10	M 16 1.5	6	22	11	GM10LCFX	GM10LA3CX	GM10L71X	GM10LMSX	
	12	M 18 1.5	6	24	12	GM12LCFX	GM12LA3CX	GM12L71X	GM12LMSX	
	15	M 22 1.5	7	30	23	GM15LCFX	GM15LA3CX	GM15L71X	GM15LMSX	
	18	M 26 1.5	8	36	37	GM18LCFX	GM18LA3CX	GM18L71X	GM18LMSX	
	22	M 30 2	8	41	46	GM22LCFX	GM22LA3CX	GM22L71X	GM22LMSX	
	28	M 36 2	9	46	58	GM28LCFX	GM28LA3CX	GM28L71X	GM28LMSX	
	35	M 45 2	9	55	71	GM35LCFX	GM35LA3CX	GM35L71X	GM35LMSX	
	42	M 52 2	10	65	123	GM42LCFX	GM42LA3CX	GM42L71X	GM42LMSX	
	S ⁴⁾	06	M 14 1.5	6	19	8	GM08LCFX	GM08LA3CX	GM08L71X	GM06LMSX
		08	M 16 1.5	6	22	11	GM10LCFX	GM10LA3CX	GM10L71X	GM10LMSX
		10	M 18 1.5	6	24	12	GM12LCFX	GM12LA3CX	GM12L71X	GM12LMSX
12		M 20 1.5	6	27	15	GM12SCFX	GM12SA3CX	GM12S71X	GM12SMSX	
14		M 22 1.5	7	30	23	GM15LCFX	GM15LA3CX	GM15L71X	GM15LMSX	
16		M 24 1.5	7	32	24	GM16SCFX	GM16SA3CX	GM16S71X	GM16SMSX	
20		M 30 2	8	41	46	GM22LCFX	GM22LA3CX	GM22L71X	GM22LMSX	
25		M 36 2	9	46	58	GM28LCFX	GM28LA3CX	GM28L71X	GM28LMSX	
30		M 42 2	9	50	58	GM30SCFX	GM30SA3CX	GM30S71X	GM30SMSX	
38		M 52 2	10	65	123	GM42LCFX	GM42LA3CX	GM42L71X	GM42LMSX	

³⁾ L = light series; ⁴⁾ S = heavy series

VH Support sleeve

for thin-walled metal tubing

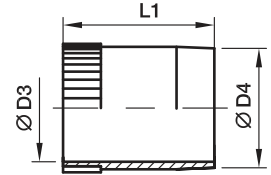

Tube I.D.	D3	D4	L1	Weight g/1 piece	Order code			
					Steel CF	Steel A3C	Stainless Steel 71	Brass MS
4.0	2.6	3.8	14.0	0.7	VH04CFX	VH04A3CX	VH0471X	VH04MSX
4.5	3.1	4.3	14.0	0.8	VH04.5CFX	VH04.5A3CX	VH04.571X	VH04.5MSX
5.0	3.6	4.8	14.0	0.8	VH05CFX	VH05A3CX	VH0571X	VH05MSX
6.0	4.6	5.8	14.0	1.0	VH06CFX	VH06A3CX	VH0671X	VH06MSX
6.5	5.1	6.3	14.0	1.0	VH06.5CFX	VH06.5A3CX	VH06.571X	VH06.5MSX
7.0	5.6	6.8	15.5	1.3	VH07CFX	VH07A3CX	VH0771X	VH07MSX
8.0	6.6	7.8	15.5	1.6	VH08CFX	VH08A3CX	VH0871X	VH08MSX
9.0	7.6	8.8	15.5	1.8	VH09CFX	VH09A3CX	VH0971X	VH09MSX
10.0	8.6	9.8	15.5	2.1	VH10CFX	VH10A3CX	VH1071X	VH10MSX
10.5	9.1	10.3	15.5	2.3	VH10.5CFX	VH10.5A3CX	VH10.571X	VH10.5MSX
11.0	9.6	10.8	15.5	2.6	VH11CFX	VH11A3CX	VH1171X	VH11MSX
12.0	10.2	11.8	17.0	3.7	VH12CFX	VH12A3CX	VH1271X	VH12MSX
13.0	11.2	12.8	17.0	3.9	VH13CFX	VH13A3CX	VH1371X	VH13MSX
14.0	12.2	13.8	17.0	4.3	VH14CFX	VH14A3CX	VH1471X	VH14MSX
15.0	13.2	14.8	20.0	5.7	VH15CFX	VH15A3CX	VH1571X	VH15MSX
16.0	14.2	15.8	20.0	5.8	VH16CFX	VH16A3CX	VH1671X	VH16MSX
17.0	15.2	16.8	20.0	6.3	VH17CFX	VH17A3CX	VH1771X	VH17MSX
18.0	16.2	17.8	20.0	6.3	VH18CFX	VH18A3CX	VH1871X	VH18MSX
19.0	17.2	18.8	16.0	5.8	VH19CFX	VH19A3CX	VH1971X	VH19MSX
20.0	18.2	19.8	21.5	7.9	VH20CFX	VH20A3CX	VH2071X	VH20MSX
21.0	19.2	20.8	21.5	8.0	VH21CFX	VH21A3CX	VH2171X	VH21MSX
22.0	20.2	21.8	23.5	9.7	VH22CFX	VH22A3CX	VH2271X	VH22MSX
23.0	21.2	22.8	23.5	10.6	VH23CFX	VH23A3CX	VH2371X	VH23MSX
24.0	22.2	23.8	23.5	11.1	VH24CFX	VH24A3CX	VH2471CX	VH24MSX
25.0	23.2	24.8	23.5	10.8	VH25CFX	VH25A3CX	VH2571X	VH25MSX
26.0	24.2	25.8	23.5	12.7	VH26CFX	VH26A3CX	VH2671X	VH26MSX
27.0	25.2	26.8	23.5	12.2	VH27CFX	VH27A3CX	VH2771X	VH27MSX
30.0	27.8	29.8	26.5	18.7	VH30CFX	VH30A3CX	VH3071X	VH30MSX
31.0	28.8	30.8	26.5	20.7	VH31CFX	VH31A3CX	VH3171X	VH31MSX
32.0	29.8	31.8	26.5	19.2	VH32CFX	VH32A3CX	VH3271X	VH32MSX
33.0	30.8	32.8	26.5	19.9	VH33CFX	VH33A3CX	VH3371X	VH33MSX
34.0	31.8	33.8	26.5	26.5	VH34CFX	VH34A3CX	VH3471X	VH34MSX
38.0	35.8	37.8	21.0	19.7	VH38CFX	VH38A3CX	VH3871X	VH38MSX
39.0	36.8	38.8	21.0	19.5	VH39CFX	VH39A3CX	VH3971X	VH39MSX

E Tube/hose insert

for plastic tubing

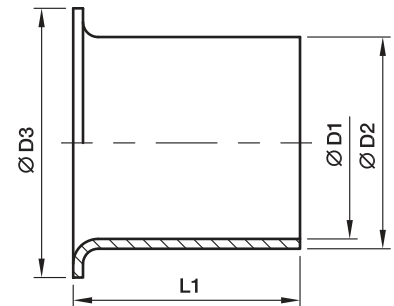

Tube O.D.	Tube I.D.	D1	D2	D3	L1	Weight g/1 piece	Order code Brass
04	2.0	1.3	2.0	3.5	8	1	E04/02X
04	2.5	1.7	2.5	4.0	8	1	E04/2.5X
05	3.0	2.2	3.0	5.0	14	1	E0506/03X
06	3.0	2.2	3.0	5.0	14	1	E0506/03X
05	4.0	3.2	4.0	5.0	14	1	E0506/04X
06	4.0	3.2	4.0	5.0	14	1	E0506/04X
08	4.0	3.2	4.0	6.6	14	1	E08/04X
06	5.0	4.0	5.0	6.0	14	1	E06/05X
08	5.0	4.0	5.0	6.0	14	1	E08/05X
10	6.0	5.0	6.0	8.0	15	1	E0810/06X
08	6.0	5.0	6.0	8.0	15	1	E0810/06X
10	8.0	6.7	8.0	10.0	15	1	E10/08X
12	8.0	6.7	8.0	12.0	15	2	E12/08X
12	9.0	7.7	9.0	12.0	15	2	E12/09X
12	10.0	8.7	10.0	12.0	15	2	E1215/10X
15	12.0	10.7	12.0	14.8	15	3	E15/12X
15	12.5	11.2	12.5	14.8	15	3	E1516/12.5X
16	12.5	11.2	12.5	14.8	15	3	E1516/12.5X
18	14.0	12.7	14.0	17.8	15	4	E18/14X
18	16.0	14.7	16.0	17.8	20	4	E1820/16X
20	16.0	14.7	16.0	17.8	20	4	E1820/16X
22	18.0	16.7	18.0	21.8	16	5	E22/18X

DOZ EO-2 Soft sealing ring

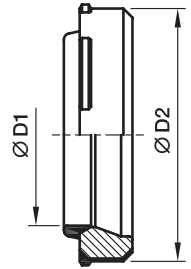

Assembl direction:
Sealing lip shows to the tube end

Series	D1 	D2	Weight g/1 piece	Order code			
				Steel NBR	Steel FKM	Stainless Steel FKM	Stainless Steel NBR
LL ²⁾	04	6.8	1	DOZ04LL	—	—	—
	06	8.8	1	DOZ06LL	—	—	—
L ³⁾	06	10.3	1	DOZ06L	DOZ06LVIT	DOZ06L71	DOZ06LNBR71
	08	12.3	1	DOZ08L	DOZ08LVIT	DOZ08L71	DOZ08LNBR71
	10	14.3	2	DOZ10L	DOZ10LVIT	DOZ10L71	DOZ10LNBR71
	12	16.3	2	DOZ12L	DOZ12LVIT	DOZ12L71	DOZ12LNBR71
	15	20.3	3	DOZ15L	DOZ15LVIT	DOZ15L71	DOZ15LNBR71
	18	24.3	5	DOZ18L	DOZ18LVIT	DOZ18L71	DOZ18LNBR71
	22	27.7	6	DOZ22L	DOZ22LVIT	DOZ22L71	DOZ22LNBR71
	28	33.7	7	DOZ28L	DOZ28LVIT	DOZ28L71	DOZ28LNBR71
	35	42.7	14	DOZ35L	DOZ35LVIT	DOZ35L71	DOZ35LNBR71
	42	49.7	17	DOZ42L	DOZ42LVIT	DOZ42L71	DOZ42LNBR71
S ⁴⁾	06	12.3	2	DOZ06S	DOZ06SVIT	DOZ06S71	DOZ06SNBR71
	08	14.3	2	DOZ08S	DOZ08SVIT	DOZ08S71	DOZ08SNBR71
	10	16.3	3	DOZ10S	DOZ10SVIT	DOZ10S71	DOZ10SNBR71
	12	18.3	4	DOZ12S	DOZ12SVIT	DOZ12S71	DOZ12SNBR71
	14	20.3	4	DOZ14S	DOZ14SVIT	DOZ14S71	DOZ14SNBR71
	16	22.3	5	DOZ16S	DOZ16SVIT	DOZ16S71	DOZ16SNBR71
	20	27.7	9	DOZ20S	DOZ20SVIT	DOZ20S71	DOZ20SNBR71
	25	33.7	13	DOZ25S	DOZ25SVIT	DOZ25S71	DOZ25SNBR71
	30	39.7	18	DOZ30S	DOZ30SVIT	DOZ30S71	DOZ30SNBR71
	38	49.7	27	DOZ38S	DOZ38SVIT	DOZ38S71	DOZ38SNBR71

²⁾ LL = very light series; ³⁾ L = light series; ⁴⁾ S = heavy series

ED Eolastic soft seal (for BSPP and metric parallel threads)

For Type: GE...ED, EGE...ED, EVGE...ED, EW...ED, EV...ED, ET...ED, EL...ED, VSTI...ED, RI...ED

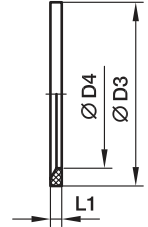

Male stud metric thread T1	Male stud BSP thread T1	D3	D4	L1	Weight g/1 piece	Order code NBR	Order code FKM
M 8 1		9.9	6.5	1.0	0.1	ED8X1X	ED8X1VITX
M 10 1	G 1/8 A	11.9	8.4	1.0	0.1	ED10X1X	ED10X1VITX
M 12 1.5		14.4	9.8	1.5	0.2	ED12X1.5X	ED12X1.5VITX
M 14 1.5	G 1/4 A	16.5	11.6	1.5	0.2	ED14X1.5X	ED14X1.5VITX
M 16 1.5		18.9	13.8	1.5	0.1	ED16X1.5X	ED16X1.5VITX
	G 3/8 A	18.9	14.7	1.5	0.2	ED3/8X	ED3/8VITX
M 18 1.5		20.9	15.7	1.5	0.1	ED18X1.5X	ED18X1.5VITX
M 20 1.5		22.9	17.8	1.5	0.2	ED20X1.5X	ED20X1.5VITX
	G 1/2 A	23.9	18.5	1.5	0.3	ED1/2X	ED1/2VITX
M 22 1.5		24.3	19.6	1.5	0.2	ED22X1.5X	ED22X1.5VITX
M 26 1.5	G 3/4 A	29.2	23.9	1.5	0.4	ED26X1.5X	ED26X1.5VITX
M 27 2	G 3/4 A	29.2	23.9	1.5	0.4	ED26X1.5X	ED26X1.5VITX
M 33 2	G 1 A	35.7	29.7	2.0	0.7	ED33X2X	ED33X2VITX
M 42 2	G 1 1/4 A	45.8	38.8	2.0	0.9	ED42X2X	ED42X2VITX
M 48 2	G 1 1/2 A	50.7	44.7	2.0	1.0	ED48X2X	ED48X2VITX

OR O-Ring for fittings with EO 24° DKO swivel

For Type:

DA, EGE, EGEO, MAVE, EW, EV, ET, EL, RED, GZ, GZR, VKA, VKAM

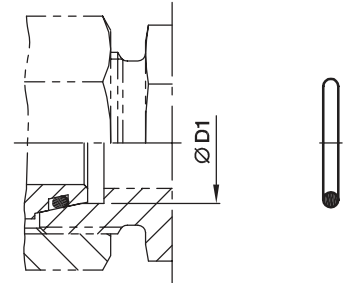

Series	D1 	O-ring NBR Shore-hardness approx. 90	O-ring FKM Shore-hardness approx. 90
L ³⁾	6	OR4.5X1.5X	OR4.5X1.5VITX
	8	OR6.5X1.5X	OR6.5X1.5VITX
	10	OR8X1.5X	OR8X1.5VITX
	12	OR10X1.5X	OR10X1.5VITX
	15	OR12X2X	OR12X2VITX
	18	OR15X2X	OR15X2VITX
	22	OR20X2X	OR20X2VITX
	28	OR26X2X	OR26X2VITX
	35	OR32X2.5X	OR32X2.5VITX
	42	OR38X2.5X	OR38X2.5VITX
S ⁴⁾	6	OR4.5X1.5X	OR4.5X1.5VITX
	8	OR6.5X1.5X	OR6.5X1.5VITX
	10	OR8X1.5X	OR8X1.5VITX
	12	OR10X1.5X	OR10X1.5VITX
	14	OR11X2X	OR11X2VITX
	16	OR13X2X	OR13X2VITX
	20	OR16.3X2.4X	OR16.3X2.4VITX
	25	OR20.3X2.4X	OR20.3X2.4VITX
	30	OR25.3X2.4X	OR25.3X2.4VITX
	38	OR33.3X2.4X	OR33.3X2.4VITX

³⁾ L = light series; ⁴⁾ S = heavy series

OR O-rings for male stud ends

Male metric thread – O-ring (ISO 6149)
 Male UN/UNF thread – O-ring (ISO 11926)

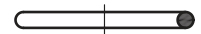
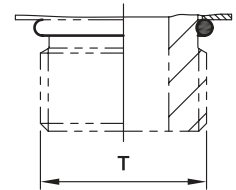

Types with metric thread: WEE-OR, TEE-OR, LEE-OR, VEE-OR, VSTI-OR, GEO, EGEO

Thread T	O-ring NBR	O-ring FKM
M8 1	OR6.1X1.6	OR6.1X1.6VITX
M10 1	OR8.1X1.6	OR8.1X1.6VITX
M12 1.5	OR9.3X2.2	OR9.3X2.2VITX
M14 1.5	OR11.3X2.2	OR11.3X2.2VITX
M16 1.5	OR13.3X2.2	OR13.3X2.2VITX
M18 1.5	OR15.3X2.2	OR15.3X2.2VITX
M22 1.5	OR19.3X2.2	OR19.3X2.2VITX
M27 2	OR23.6X2.9	OR23.6X2.9VITX
M33 2	OR29.6X2.9	OR29.6X2.9VITX
M42 2	OR38.6X2.9	OR38.6X2.9VITX
M48 2	OR44.6X2.9	OR44.6X2.9VITX

Types with UN/UNF thread:
 WEE-UNF, TEE-UNF, LEE-UNF, VEE-UNF, GE-UNF

Thread T	O-ring NBR	O-ring FKM
7/16-20 UNF	OR8.92X1.83	OR8.92X1.83VITX
9/16-18 UNF	OR11.89X1.98	OR11.89X1.98VITX
3/4-16 UNF	OR16.36X2.21	OR16.36X2.21VITX
7/8-14 UNF	OR19.18X2.46	OR19.18X2.46VITX
1 1/16-12 UN	OR23.47X2.95	OR23.47X2.95VITX
1 5/16-12 UN	OR29.74X2.95	OR29.74X2.95VITX
1 5/8-12 UN	OR37.46X3	OR37.46X3VITX
1 7/8-12 UN	OR43.69X3	OR43.69X3VITX

OR O-rings and retaining rings for steel male stud ends

Adjustable metric thread – O-ring + retaining ring
 Adjustable BSPP thread – O-ring + retaining ring (ISO 1179)

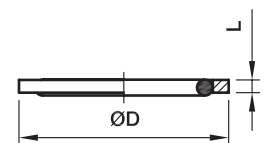
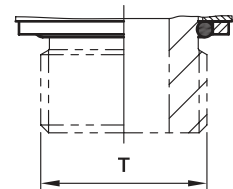

Types with metric thread: WEE-M, TEE-M, LEE-M, VEE-M

Thread T	O-ring NBR	O-ring FKM	D	L	Order code Retaining ring	
					CF	A3C
M10 1	OR8X1.88X	OR8X1.88VITX	14.8	1.4	RRSM10CF	RRSM10A3C
M12 1.5	OR9.3X2.2X	OR9.3X2.2VITX	17.8	1.6	RRSM12CF	RRSM12A3C
M14 1.5	OR11.3X2.2X	OR11.3X2.2VITX	19.8	1.6	RRSM14CF	RRSM14A3C
M16 1.5	OR13.3X2.2X	OR13.3X2.2VITX	22.8	1.6	RRSM16CF	RRSM16A3C
M18 1.5	OR15.54X2.62X	OR15.54X2.62VITX	24.8	2.1	RRSM18CF	RRSM18A3C
M22 1.5	OR19.3X2.2X	OR19.3X2.2VITX	27.8	1.8	RRSM22CF	RRSM22A3C
M27 2	OR23X3X	OR23X3VITX	32.8	2.3	RRSM27CF	RRSM27A3C
M33 2	OR29.2X3X	OR29.2X3VITX	40.8	2.5	RRSM33CF	RRSM33A3C
M42 2	OR37.69X3.53X	OR37.69X3.53VITX	50.8	2.6	RRSM42CF	RRSM42A3C
M48 2	OR43.69X3X	OR43.69X3VITX	55.8	2.3	RRSM48CF	RRSM48A3C

Types with BSPP thread: WEE-R, TEE-R, LEE-R, VEE-R

Thread T	O-ring NBR	O-ring FKM	D	L	Order code Retaining ring	
					CF	A3C
G 1/8 A	OR8X1.88X	OR8X1.88VITX	14.8	1.4	RRS1/8CF	RRS1/8A3C
G 1/4 A	OR10.77X2.62X	OR10.77X2.62VITX	19.8	1.9	RRS1/4CF	RRS1/4A3C
G 3/8 A	OR13.94X2.62X	OR13.94X2.62VITX	22.8	2.0	RRS3/8CF	RRS3/8A3C
G 1/2 A	OR18X3.15X	OR18X3.15VITX	27.8	2.6	RRS1/2CF	RRS1/2A3C
G 3/4 A	OR23X3X	OR23X3VITX	32.8	2.5	RRS3/4CF	RRS3/4A3C
G 1 A	OR29.74X3.53X	OR29.74X3.53VITX	40.8	2.5	RRS1CF	RRS1A3C
G 1 1/4 A	OR37.69X3.53X	OR37.69X3.53VITX	50.8	2.6	RRS1 1/4CF	RRS1 1/4A3C
G 1 1/2 A	OR44.04X3.53X	OR44.04X3.53VITX	55.8	2.6	RRS1 1/2CF	RRS1 1/2A3C

OR O-rings and retaining rings for stainless steel male stud ends

Adjustable metric thread – O-ring + retaining ring

Adjustable BSPP thread – O-ring + retaining ring (ISO 1179)

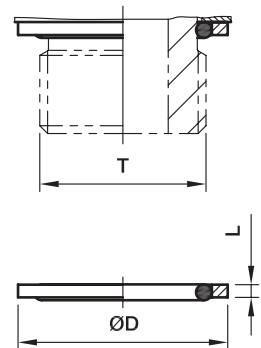

Types with metric thread: WEE-M, TEE-M, LEE-M, VEE-M

Thread T	O-ring FKM	O-ring NBR	D	L	Order code Retaining ring Stainless Steel
M10 1	OR8X1.5VITX	OR8X1.5X	14.8	1.0	RRM10X1SS
M12 1.5	OR9.25X1.78VITX	OR9.25X1.78X	17.8	1.3	RRM12X1.5SS
M14 1.5	OR11X2VITX	OR11X2X	19.8	1.3	RRM14X1.5SS
M16 1.5	OR13.4X2.1VITX	OR13.4X2.1X	21.8	1.5	RRM16X1.5SS
M18 1.5	OR15.54X2.62VITX	OR15.54X2.62X	23.8	2.0	RRM18X1.5SS
M22 1.5	OR18.77X1.78VITX	OR18.77X1.78X	27.8	1.3	RRM22X1.5SS
M27 2	OR23.47X2.62VITX	OR23.47X2.62X	32.8	2.0	RRM27X2SS
M33 2	OR29.7X2.8VITX	OR29.7X2.8X	39.8	2.0	RRM33X2SS
M42 2	OR37.7X2.62VITX	OR37.7X2.62X	49.8	2.0	RRM42X2SS
M48 2	OR44.12X2.62VITX	OR44.12X2.62X	55.0	2.0	RRM48X2SS

Types with parallel thread: WEE-R, TEE-R, LEE-R, VEE-R

Thread T	O-ring FKM	O-ring NBR	D	L	Order code Retaining ring Stainless Steel
G 1/8 A	OR8X1.88VITX	OR8X1.88X	15.0	1.4	8207SS1/8
G 1/4 A	OR10.77X2.62VITX	OR10.77X2.62X	19.5	1.9	8207SS1/4A
G 3/8 A	OR13.94X2.62VITX	OR13.94X2.62X	23.5	1.9	8207SS3/8A
G 1/2 A	OR17.96X2.62VITX	OR17.96X2.62X	28.5	1.9	8207SS1/2
G 3/4 A	OR23.47X2.62VITX	OR23.47X2.62X	34.5	1.9	8207SS3/4
G 1 A	OR29.74X3.53VITX	OR29.74X3.53X	43.5	2.6	8207SS1A
G 1 1/4 A	OR37.69X3.53VITX	OR37.69X3.53X	52.5	2.6	8207SS1 1/4
G 1 1/2 A	OR44.04X3.53VITX	OR44.04X3.53X	60.0	2.6	8207SS1 1/2

OR O-Rings for banjo fittings WH/TH

For WH / TH	For WH / TH	O-ring NBR	O-ring FKM
06LM/LR		OR9.3X1.5X	OR9.3X1.5VITX
08LM/LR	06SM/SR	OR12.5X1.5X	OR12.5X1.5VITX
10LM/LR	08SM/SR	OR12.5X1.5X	OR12.5X1.5VITX
12LM/LR	10SM/SR	OR16X1.5X	OR16X1.5VITX
	12SR	OR16X1.5X	OR16X1.5VITX
15LM	12SM	OR18X1.5X	OR18X1.5VITX
15LR	14SM/SR	OR20X1.5X	OR20X1.5VITX
18LM/LR	16SM/SR	OR20X1.5X	OR20X1.5VITX
22LM/LR	20SM/SR	OR25X2X	OR25X2VITX
28LM/LR	25SM/SR	OR33X2.5X	OR33X2.5VITX
35LM/LR	30SM/SR	OR41X2.5X	OR41X2.5VITX
42LM/LR	38SM/SR	OR46X3X	OR46X3VITX

DKI Sealing ring for pressure gauge connectors

Female thread	D1	D2	L1	Weight g/1 piece	Order code		
					Steel CF	Steel A3C	Stainless Steel 71
G 1/4 A	6	11.3	4.5	2.5	DKI1/4CFX	DKI1/4A3CX	DKI1/471X
G 1/2 A	12	18.5	5.0	5.0	DKI1/2CFX	DKI1/2A3CX	DKI1/271X

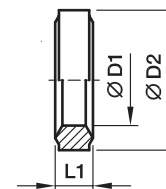

KDS Soft sealing ring for banjo fittings WH/TH from steel

for small and wide spot faces of ports

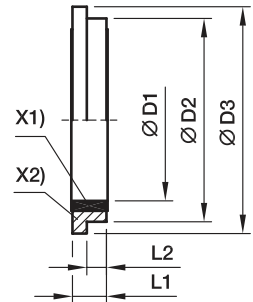

X1) NBR sealing
X2) Supporting-ring (Steel)

For WH and TH	For thread		D1	D2	D3	L1	L2	Weight g/1 piece	Order code Steel/NBR	Order code Steel/FKM
06LM/LRKDS	M10 1	G 1/8 A	10.3	14.9	16.0	2.5	1.1	2	KDS10A3CX	KDS10VITA3CX
06SM/08LMKDS	M12 1.5		12.3	17.0	18.0	3.0	1.6	2	KDS12A3CX	KDS12VITA3CX
06SRKDS	M14 1.5	G 1/4 A	14.3	18.9	20.0	3.0	1.6	2	KDS14A3CX	KDS14VITA3CX
08LR/SM/SRKDS	M14 1.5	G 1/4 A	14.3	18.9	20.0	3.0	1.6	2	KDS14A3CX	KDS14VITA3CX
10LM/LRKDS	M14 1.5	G 1/4 A	14.3	18.9	20.0	3.0	1.6	2	KDS14A3CX	KDS14VITA3CX
10SM/SRKDS	M16 1.5	G 3/8 A	17.0	21.9	24.0	3.0	2.1	3	KDS16A3CX	KDS16VITA3CX
12LM/LR/SRKDS	M16 1.5	G 3/8 A	17.0	21.9	24.0	3.0	2.1	3	KDS16A3CX	KDS16VITA3CX
12SM/15LMKDS	M18 1.5		18.3	23.9	23.9	3.0		4	KDS18A3CX	KDS18VITA3CX
15LRKDS	M22 1.5	G 1/2 A	22.3	26.9	30.0	4.5	2.6	7	KDS22A3CX	KDS22VITA3CX
16SM/SRKDS	M22 1.5	G 1/2 A	22.3	26.9	30.0	4.5	2.6	7	KDS22A3CX	KDS22VITA3CX
18LM/LRKDS	M22 1.5	G 1/2 A	22.3	26.9	30.0	4.5	2.6	7	KDS22A3CX	KDS22VITA3CX
22LMKDS	M26 1.5		26.3	31.9	35.0	3.5	2.6	7	KDS26A3CX	KDS26VITA3CX
20SM/SRKDS	M27 2	G 3/4 A	27.3	32.9	38.0	3.5	2.6	8	KDS27A3CX	KDS27VITA3CX
22LRKDS	M27 2	G 3/4 A	27.3	32.9	38.0	3.5	2.6	8	KDS27A3CX	KDS27VITA3CX
25SM/SRKDS	M33 2	G 1 A	33.6	39.9	42.0	3.5	2.6	10	KDS33A3CX	KDS33VITA3CX
28LM/LRKDS	M33 2	G 1 A	33.6	39.9	42.0	3.5	2.6	10	KDS33A3CX	KDS33VITA3CX
30SM/SRKDS	M42 2	G 1 1/4 A	42.4	49.9	49.9	3.5		12	KDS42A3CX	KDS42VITA3CX
35LM/LRKDS	M42 2	G 1 1/4 A	42.4	49.9	49.9	3.5		12	KDS42A3CX	KDS42VITA3CX
38SM/SRKDS	M48 2	G 1 1/2 A	48.4	55.9	60.0	3.5	2.6	16	KDS48A3CX	KDS48VITA3CX
42LM/LRKDS	M48 2	G 1 1/2 A	48.4	55.9	60.0	3.5	2.6	16	KDS48A3CX	KDS48VITA3CX

KD Soft sealing ring for banjo fittings WH/TH from stainless steel

for wide spot faces of ports

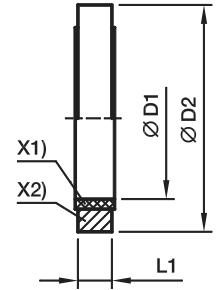

X1) PTFE sealing
X2) Supporting-ring (Stainless Steel)

For WH and TH	For thread	D1	D2	L1	Weight g/1 piece	Order code
06LRKD71	G 1/8 A	10.0	17.0	2.5	2	KD1/871
08LR/06SRKD71	G 1/4 A	13.5	22.0	3.0	4	KD1/471
10LR/08SRKD71	G 1/4 A	13.5	22.0	3.0	4	KD1/471
12LR/10SRKD71	G 3/8 S	17.1	27.0	3.0	6	KD3/871
12SRKD71	G 3/8 A	17.1	27.0	3.0	6	KD3/871
15LR/14SRKD71	G 1/2 A	21.4	32.0	4.5	12	KD1/271
18LR/16SRKD71	G 1/2 A	21.4	32.0	4.5	12	KD1/271
22LR/20SRKD71	G 3/4 A	26.8	41.0	3.5	17	KD3/471
28LR/25SRKD71	G 1 A	33.5	46.0	3.5	17	KD171
35LR/30SRKD71	G 1 1/4 A	42.4	57.0	3.5	26	KD11/471
42LR/38SRKD71	G 1 1/2 A	48.4	64.0	3.5	35	KD11/271
06LMKD71	M 10 1	10.3	17.0	2.5	2	KD1071
08LM/06SMKD71	M 12 1.5	12.3	22.0	3.0	5	KD1271
10LM/08SMKD71	M 14 1.5	14.3	22.5	3.0	5	KD1471
12LM/10SMKD71	M 16 1.5	16.4	27.0	3.0	9	KD1671
15LM/12SMKD71	M 18 1.5	18.4	29.0	3.0	9	KD1871
14SMKD71	M 20 1.5	20.4	32.0	3.0	9	KD2071
18LM/16SMKD71	M 22 1.5	22.4	32.0	4.5	12	KD2271
22LMKD71	M 26 1.5	26.4	41.0	3.5	18	KD2671
20SMKD71	M 27 2	27.4	41.0	3.5	18	KD2771
28LM/25SMKD71	M 33 2	33.5	46.0	3.5	17	KD171
35LM/30SMKD71	M 42 2	42.4	57.0	3.5	26	KD11/471
42LM/38SMKD71	M 48 2	48.4	64.0	3.5	35	KD11/271

DKAZ Sealing ring

for low pressure banjos DSVW

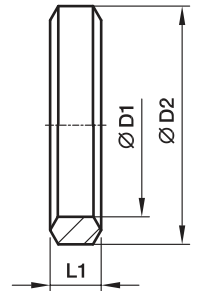

For DSVW		Metric thread parallel	D1	D2	L1	Weight g/1 piece	Order code	
							Steel CF	Steel A3C
06LM		M10 1	10.1	14	3.2	2	DKAZ10CFX	DKAZ10A3CX
08LM	06SM	M12 1.5	12.1	17	4.2	3	DKAZ12CFX	DKAZ12A3CX
10LM	08SM	M14 1.5	14.1	19	4.5	4	DKAZ14CFX	DKAZ14A3CX
12LM	10SM	M16 1.5	16.1	21	4.5	4	DKAZ16CFX	DKAZ16A3CX
15LM	12SM	M18 1.5	18.1	23	4.5	5	DKAZ18CFX	DKAZ18A3CX
	14SM	M20 1.5	20.1	25	4.5	5	DKAZ20CFX	DKAZ20A3CX
18LM	16SM	M22 1.5	22.1	27	4.5	6	DKAZ22CFX	DKAZ22A3CX
22LM		M26 1.5	26.1	31	4.5	7	DKAZ26CFX	DKAZ26A3CX
		M27 2	27.1	32	5.0	8	DKAZ27CFX	DKAZ27A3CX
28LM	20SM	M33 2	33.1	39	6.0	15	DKAZ33CFX	DKAZ33A3CX
35LM	30SM	M42 2	42.1	49	6.5	22	DKAZ11/4CFX	DKAZ11/4A3CX
42LM	38SM	M48 2	48.1	55	6.5	25	DKAZ11/2CFX	DKAZ11/2A3CX

For DSVW		BSPP thread parallel	D1	D2	L1	Weight g/1 piece	Order code	
							Steel CF	Steel A3C
06LR		G1/8A	9.8	14	3.2	2	DKAZ1/8CFX	DKAZ1/8A3CX
08LR/10LR	06SR/08SR	G1/4A	13.3	18	4.5	4	DKAZ1/4CFX	DKAZ1/4A3CX
12LR	10SR/12SR	G3/8A	16.8	22	4.5	5	DKAZ3/8CFX	DKAZ3/8A3CX
15LR/18LR	14SR/16SR	G1/2A	21.1	26	5.0	6	DKAZ1/2CFX	DKAZ1/2A3CX
22LR	20SR	G3/4A	26.6	32	5.0	11	DKAZ3/4CFX	DKAZ3/4A3CX
28LR	25SR	G1A	33.4	39	6.0	14	DKAZ1CFX	DKAZ1A3CX
35LR	30SR	G11/4A	42.1	49	6.5	22	DKAZ11/4CFX	DKAZ11/4A3CX
42LR	38SR	G11/2A	48.1	55	6.5	25	DKAZ11/2CFX	DKAZ11/2A3CX

DKA Sealing ring

for banjo fittings WH/TH and SWVE

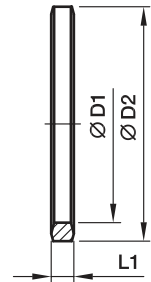

WH/TH		For: SWVE		BSPB thread	D1	D2	L1	Weight g/1 piece	Steel CF	Order code Steel A3C	Stainless Steel 71
06LR		04/06/08-LLR	06LR	G 1/8 A	9.8	14	2.5	1	DKA1/8CFX	DKA1/8A3CX	DKA1/871X
08LR	06SR	08LR	06SR	G 1/4 A	13.3	18	3.0	3	DKA1/4CFX	DKA1/4A3CX	DKA1/471X
10LR	08SR	10LR	08SR	G 1/4 A	13.3	18	3.0	3	DKA1/4CFX	DKA1/4A3CX	DKA1/471X
12LR	10SR	12LR	10SR	G 3/8 A	16.8	22	3.0	3	DKA3/8CFX	DKA3/8A3CX	DKA3/871X
	12SR		12SR	G 3/8 A	16.8	22	3.0	3	DKA3/8CFX	DKA3/8A3CX	DKA3/871X
		15/18LR	14/16SR	G 1/2 A	21.1	26	3.0	4	DKA1/2CFX	DKA1/2A3CX	
15LR	14SR			G 1/2 A	21.1	26	4.5	6	DKA1/2X4.5CFX	DKA1/2X4.5A3CX	DKA1/2X4.571X
18LR	16SR			G 1/2 A	21.1	26	4.5	6	DKA1/2X4.5CFX	DKA1/2X4.5A3CX	DKA1/2X4.571X
22LR	20SR	22LR	20SR	G 3/4 A	26.6	32	3.5	6	DKA3/4CFX	DKA3/4A3CX	DKA3/471X
28LR	25SR			G 1 A	33.4	39	3.5	8	DKA1CFX	DKA1A3CX	DKA171X
35LR	30SR			G 1 1/4 A	42.1	49	3.5	12	DKA11/4CFX	DKA11/4A3CX	DKA11/471X
42LR	38SR			G 1 1/2 A	48.1	55	3.5	15	DKA11/2CFX	DKA11/2A3CX	DKA11/271X

WH/TH		For: SWVE		Male stud metric thread	D1	D2	L1	Weight g/1 piece	Steel CF	Order code Steel A3C	Stainless Steel 71
06LM		04LLM	06LM	M 8 1	8.1	12	2.5	1	DKA08CFX	DKA08A3CX	
08LM	06SM	06/08LLM	06SM	M 10 1	10.1	14	3.0	1	DKA10CFX	DKA10A3CX	DKA1071X
10LM	08SM	10LM	08SM	M 12 1.5	12.1	17	3.0	2	DKA12CFX	DKA12A3CX	DKA1271X
12LM	10SM	12LM	10SM	M 14 1.5	14.1	19	3.0	3	DKA14CFX	DKA14A3CX	DKA1471X
				M 16 1.5	16.1	21	3.0	3	DKA16CFX	DKA16A3CX	DKA1671X
15LM	12SM	15LM	12SM	M 18 1.5	18.1	23	3.0	3	DKA18CFX	DKA18A3CX	DKA1871X
	14SM		14-SM	M 20 1.5	20.1	25	3.0	4	DKA20CFX	DKA20A3CX	DKA2071X
		18LM	16SM	M 22 1.5	22.1	27	3.0	4	DKA22CFX	DKA22A3CX	
18LM	16SM			M 22 1.5	22.1	27	4.5	6	DKA22X4.5CFX	DKA22X4.5A3CX	DKA22X4.571X
			22LM	M 26 1.5	26.1	31	3.0	6	DKA26CFX	DKA26A3CX	
22LM		20SM	20SM	M 26 1.5	26.1	31	3.5	6	DKA26X3.5CFX	DKA26X3.5A3CX	DKA26X3.571X
				M 27 2	27.1	32	3.5	6	DKA27CFX	DKA27A3CX	DKA2771X
28LM	25SM			M 33 2	33.1	39	3.5	8	DKA33CFX	DKA33A3CX	DKA3371X
35LM	30SM			M 42 2	42.1	49	3.5	12	DKA11/4CFX	DKA11/4A3CX	DKA11/471X
42LM	38SM			M 48 2	48.1	55	3.5	15	DKA11/2CFX	DKA11/2A3CX	DKA11/271X













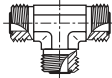
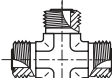
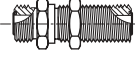
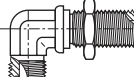
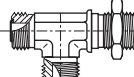

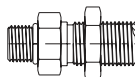
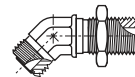

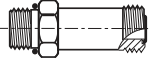

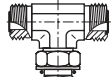
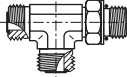
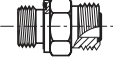

O-Lok[®]

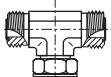
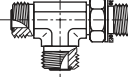
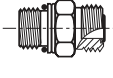



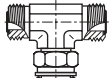
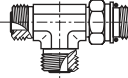
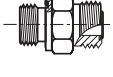

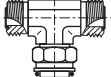
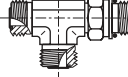
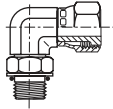
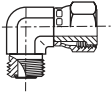
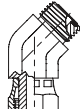
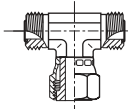
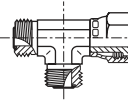



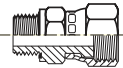

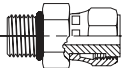
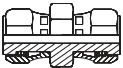
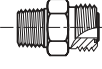
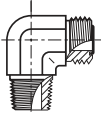
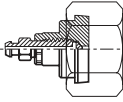
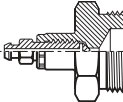



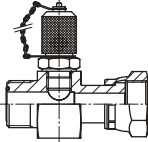

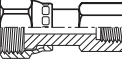
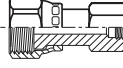



O-Ring face seal tube fittings

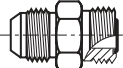
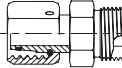

Visual index

Tube-Tube unions							
	HMLO p. J9	EMLO p. 10	JMLO p. J11	KLO p. J12			
Bulkhead unions							
	WMLO p. J13	WEMLO p. J14	WJJLO p. J17	WJLO p. J16	WF5OLO p. J29	WNLO p. J15	WLNML p. J72
Tube to UNF thread							
	F50MLO p. J27	FF50MLO p. J28	C50MLO p. J39	CC50LO p. J40	V50MLO p. J45	S50MLO p. J49	R50MLO p. J53
Tube to BSPP thread							
	F42EDMLO p. J30	C40MLO p. J41	V40MLO p. J46	S40MLO p. J50	R40MLO p. J54		
Tube to metric ISO 6149-2 thread							
	F870MLO p. J26	C870MLO p. J37	CC870MLO p. J38	V870MLO p. J44	S870MLO p. J48	R870MLO p. J52	
Tube to metric DIN 3852 thread							
	F82EDMLO p. J31	C80MLO p. J42	V80MLO p. J47	S80MLO p. J51	R80MLO p. J55		
Swivel fittings							
	AOEL6 p. J18	C6MLO p. J19	V6LO p. J20	S6MLO p. J21	R6MLO p. J22		

Visual index

Swivel nut to straight thread	 F642EDMLO p. J35	 F682EDMLO p. J36	 F687OML p. J33	 F650L p. J34	 HL6 p. J25		
Tube to NPTF thread	 FLO p. J32	 CLO p. J43	<p>Taper threads should not be used for new projects or designs. Parker Hannifin recommends elastomerically sealed components.</p>				
Bleed adapters	 FNLBA p. J69	 PNLOBA p. J70	 HPBA p. J71	 P50NBA p. J71			
Test point and gauge adapters	 TTP4ML p. J60	 R6P4MLO p. J61	 G4MLOSMO p. J57	 TT4ML p. J58	 TT8ML p. J59	 G87MLO p. J56	
Sleeves for metric and inch tube	 TPL p. J6	 TL p. J7	 TL-Reducer sleeve p. J8	<p>Nuts & Reducers</p>  BML/BL p. J5		 TRMLO p. J23	 LOHL6 p. J24
	 XHML0 p. J65					 LOHU86 p. J68	
Accessories	 LOHB3 p. J62	 FNML p. J63	 PNMLO p. J64	 O-ring p. J73-74	 SBR Braze ring p. J75	 TW3L p. J72	

J

How to order O-Lok® fittings

Example Order code **6-8 C 5 O M L O S**

1 2 3 4 5 6 7 8

1 Order codes for tube and port thread ends

Dash Size	Tube Size (Inch)	Tube Size (mm)	Port Thread Size (Inch) BSPP/BSPT/NPT	Port Thread Size UN / UNF
4	1/4	6	1/4	7/16-20
5				1/2-20
6	3/8	8,10	3/8	9/16-18
8	1/2	12	1/2	3/4-16
10	5/8	14,15,16	5/8	7/8-14
12	3/4	18,20	3/4	1 1/6-12
14				1 3/6-12
16	1	25	1	1 5/6-12
20	1 1/4	28,30,32	1 1/4	1 5/8-12
24	1 1/2	35,38	1 1/2	1 7/8-12
32	2	50	2	2 1/2-12

Metric port threads are shown as per example 4M12C87OMLOS

3 Threads and sealing methods

Code	Description
None	NPT/NPTF Thread
3	BSPT Thread
4	BSPP Thread O-Ring & Retainer Ring
42	BSPP Thread EOLASTIC seal 'ED'
5	UN/UNF Thread (O-Ring Seal)
8	Metric Thread O-Ring & Retainer Ring
82	Metric Thread EOLASTIC seal 'ED'
87	Metric ISO 6149 Thread (O-Ring Seal)
63	Swivel Connector BSPT end
64	Swivel Connector BSPP end (O-Ring & Retainer Ring)
642	Swivel Connector BSPP end (EOLASTIC Seal 'ED')
65	Swivel Connector UN/UNF end (O-Ring seal)
68	Swivel Connector Metric end (O-Ring & Retainer Ring)
682	Swivel Connector Metric end (EOLASTIC Seal 'ED')
687	Swivel Connector Metric ISO 6149 end

2 Codes for fitting styles/shapes

Code	Description
AE6	Straight Thread Swivel
B	Nut
C	Male Stud elbow
CC	Extended Male Stud elbow
C6	Swivel Nut Elbow
E	Union elbow
F	Male Stud connector
FF	Extended Male Stud connector
F6	Male Stud Swivel
FN	Cap
FNLBAS	Bleed Adapter Cap
G	Female Connector
H	Straight union
H6	Swivel/Swivel Adapter
J	Union Tee
K	Union Cross
LOHB3	Braze Adapter
LOHX6	Triple-Lok® Swivel/O-Lok® Adapter
M	Female Run Tee
O	Female Branch Tee
PN	Plug
PNLOBA	Bleed Adapter Plug
R	Male Stud Run Tee
R6	Swivel Run Tee
S	Male Stud Branch Tee
S6	Swivel Branch Tee
SBR	Braze Ring
TPL	Parflange® sleeve
TL	Brazed sleeve
TR	Tube End Reducer
TT	Test Point Adapter
TW3	Weld Nipple
V	45° male stud elbow
V6	Swivel Nut 45° Elbow
W	Bulkhead Union
WE	Bulkhead Union Elbow
WJJ	Bulkhead Run Tee
WJT	Bulkhead Branch Tee
WLNML	Bulkhead Locknut
WN	Bulkhead 45° union elbow
XHL6	Triple Lok®/Swivel O-Lok® adaptor
XHLO	Triple Lok®/O-Lok® male adaptor

4 Stud connector seal

Code	Description
O	O-Ring Seal (Assembled on fitting)
ED	Captive EOLASTIC Seal (Assembled on fitting)
No Code	No Seal (O-Ring not assembled on fitting)

5 Hexagon/ Across flats style

Code	Description
M	Metric Hexagon Dimension
No Code	Inch Hexagon Dimension

6 Fitting type

Code	Description
L	Parker O-Lok®

7 Tube connection seal ORFS

Code	Description
O	O-Ring Seal (Assembled on Fitting)
No Code	No Seal/O-Ring

8 Fitting material

Code	Description
S	Steel
SS	Stainless Steel
B	Brass

BML Nut

O-Lok® ORFS tube nut
SAE 52M0110 ISO 8434-3 NA

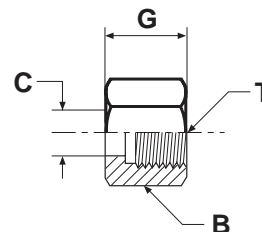

Tube O.D.		Thread UN/UNF-2B T	B mm	C mm	G mm	Weight (steel) g/1 piece	O-Lok® Steel	O-Lok® Stainless Steel
mm	in.							
6	1/4	9/16-18	17	11	15	14	4BMLS	4BMLSS
8, 10	5/16, 3/8	11/16-16	22	14	17	17	6BMLS	6BMLSS
12	1/2	13/16-16	24	17	20	29	8BMLS	8BMLSS
14, 15, 16	5/8	1-14	30	21	24	46	10BMLS	10BMLSS
18, 20	3/4	1 3/16-12	36	24	27	69	12BMLS	12BMLSS
22, 25	1	1 7/16-12	41	29	28	109	16BMLS	16BMLSS
28, 30, 32	1 1/4	1 11/16-12	50	36	28	126	20BMLS	20BMLSS
35, 38	1 1/2	2-12	60	44	28	195	24BMLS	24BMLSS
50	2	2 1/2-12	75	56	33	800	32BMLS	32BMLSS

Part numbers shown are part of our current manufacturing programme.

BL Nut

O-Lok® ORFS tube nut
SAE 520110

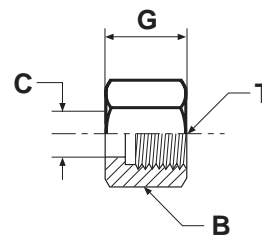

Tube O.D.		Thread UN/UNF-2B T	B in.	C mm	G mm	Weight (steel) g/1 piece	O-Lok® Steel	O-Lok® Stainless Steel
mm	in.							
6	1/4	9/16-18	11/16	10	15	16	4 BL-S	4 BL-SS
8, 10	5/16, 3/8	11/16-16	13/16	14	17	24	6 BL-S	6 BL-SS
12	1/2	13/16-16	15/16	17	21	37	8 BL-S	8 BL-SS
14, 15, 16	5/8	1-14	1 1/8	21	24	52	10 BL-S	10 BL-SS
18, 20	3/4	1 3/16-12	1 3/8	24	26	89	12 BL-S	12 BL-SS
22, 25	1	1 7/16-12	1 5/8	29	28	119	16 BL-S	16 BL-SS
28, 30, 32	1 1/4	1 11/16-12	1 7/8	36	28	132	20 BL-S	20 BL-SS
35, 38	1 1/2	2-12	2 1/4	44	28	220	24 BL-S	24 BL-SS
50	2	2 1/2-12	2 7/8	56	33	700	32 BL-S	32 BL-SS

Part numbers shown are part of our current manufacturing programme.

TPL Sleeve metric tubing

O-Lok® ORFS Parflange® tube sleeve

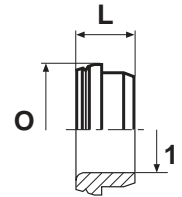

Tube O.D. 1 mm	L mm	O mm	Weight (steel) g/1 piece	O-Lok® Steel	O-Lok® Stainless Steel
6	8	13	4	TPLS6	TPLSS6
8	9	16	4	TPLS8	TPLSS8
10	9	16	5	TPLS10	TPLSS10
10	11	19	6	TPLS12-10	TPLSS12-10
12	11	19	6	TPLS12	TPLSS12
14	11	23	10	TPLS14	TPLSS14
15	11	23	9	TPLS15	TPLSS15
16	11	23	8	TPLS16	TPLSS16
18	12	28	14	TPLS18	TPLSS18
20	12	28	15	TPLS20	TPLSS20
22	14	34	20	TPLS22	TPLSS22
25	14	34	23	TPLS25	TPLSS25
28	13	41	24	TPLS28	TPLSS28
30	13	41	25	TPLS30	TPLSS30
32	13	41	26	TPLS32	TPLSS32
35	13	48	36	TPLS35	TPLSS35
38	13	48	44	TPLS38	TPLSS38
50	14	61	180	TPLS50	TPLSS50

Part numbers shown are part of our current manufacturing programme.

TPL Sleeve inch tubing

O-Lok® ORFS Parflange® tube sleeve

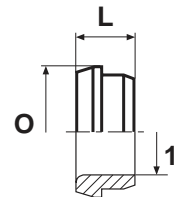

Tube O.D. 1 in.	L mm	O mm	Weight (steel) g/1 piece	O-Lok® Steel	O-Lok® Stainless Steel
1/4	8	13	4	4 TPL-S	4 TPL-SS
3/8	9	16	5	6 TPL-S	6 TPL-SS
1/2	11	19	6	8 TPL-S	8 TPL-SS
5/8	11	23	11	10 TPL-S	10 TPL-SS
3/4	12	28	19	12 TPL-S	12 TPL-SS
7/8	14	34	19	14 TPL-S	14 TPL-SS
1	14	34	22	16 TPL-S	16 TPL-SS
1 1/4	13	41	28	20 TPL-S	20 TPL-SS
1 1/2	13	48	44	24 TPL-S	24 TPL-SS
2	14	61	180	32 TPL-S	32 TPL-SS

Part numbers shown are part of our current manufacturing programme.

TL* Braze sleeve metric tubing

O-Lok® ORFS silver braze tube sleeve

SAE 52M0115 ISO 8434-3 BRSL

(*Parts delivered oil dipped finish only – steel)

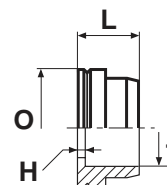

ORFS dash size	Tube O.D. 1 mm	H mm	L mm	O mm	Weight (steel) g/1 piece	O-Lok® Steel	O-Lok® Stainless Steel
4	6	1	10	13	5	TLS6	TLSS6
4	8	1	10	13	5	TLS6-8	TLSS6-8
6	8	2	10	16	7	TLS10-8	TLSS10-8
6	10	1	10	16	7	TLS10	TLSS10
8	12	1	10	19	10	TLS12	TLSS12
10	15	2	11	23	16	TLS16-15	TLSS16-15
10	16	2	11	23	16	TLS16	TLSS16
12	18	2	14	28	26	TLS20-18	TLSS20-18
12	20	2	14	28	21	TLS20	TLSS20
16	22	2	16	34	33	TLS25-22	TLSS25-22
16	25	2	16	34	30	TLS25	TLSS25
20	28	2	16	41	41	TLS32-28	TLSS32-28
20	30	2	16	41	42	TLS32-30	TLSS32-30
20	32	2	16	41	40	TLS32	TLSS32
24	35	2	16	49	48	TLS38-35	TLSS38-35
24	38	2	16	49	63	TLS38	TLSS38
32	50	2	16	60	210	TLS50	TLSS50

Part numbers shown are part of our current manufacturing programme.

TL* Braze sleeve inch tubing

O-Lok® ORFS silver braze tube sleeve

SAE 520115

(*Parts delivered oil dipped finish only – steel)

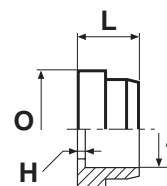

Tube O.D. 1 in.	H mm	L mm	O mm	Weight (steel) g/1 piece	O-Lok® Steel	O-Lok® Stainless Steel
1/4	1	10	13	5	4 TL-S	4 TL-SS
3/8	1	10	16	6	6 TL-S	6 TL-SS
1/2	1	10	19	10	8 TL-S	8 TL-SS
5/8	2	11	23	18	10 TL-S	10 TL-SS
3/4	2	14	28	26	12 TL-S	12 TL-SS
1	2	16	34	33	16 TL-S	16 TL-SS
1 1/4	2	16	41	42	20 TL-S	20 TL-SS
1 1/2	2	16	49	63	24 TL-S	24 TL-SS
2	2	17	61	210	32 TL-S	32 TL-SS

Part numbers shown are part of our current manufacturing programme.

TL* Reducing braze sleeve inch tubing

O-Lok® ORFS silver braze tube sleeve
 SAE 520115
 (*Parts delivered oil dipped finish only – steel)

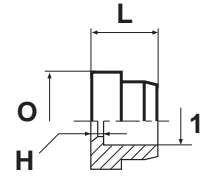

ORFS dash size	Tube O.D. 1 in.	H mm	L mm	O mm	Weight (Steel) g/1 piece	O-Lok® Steel	O-Lok® Stainless Steel
6	1/4	2	10	16	10	6-4 TL-S	6-4 TL-SS
8	1/4	4	12	19	17	8-4 TL-S	8-4 TL-SS
8	3/8	4	12	19	17	8-6 TL-S	8-6 TL-SS
10	1/4	5	14	23	37	10-4 TL-S	10-4 TL-SS
10	3/8	5	14	23	32	10-6 TL-S	10-6 TL-SS
10	1/2	5	14	23	28	10-8 TL-S	10-8 TL-SS
12	1/4	6	15	28	54	12-4 TL-S	12-4 TL-SS
12	3/8	6	15	28	49	12-6 TL-S	12-6 TL-SS
12	1/2	6	15	28	44	12-8 TL-S	12-8 TL-SS
12	5/8	6	15	28	39	12-10 TL-S	12-10 TL-SS
12	7/8	2	17	28	25	12-14 TL-S	12-14 TL-SS
16	1/2	7	16	34	76	16-8 TL-S	16-8 TL-SS
16	5/8	7	16	34	71	16-10 TL-S	16-10 TL-SS
16	3/4	5	17	34	66	16-12 TL-S	16-12 TL-SS
16	7/8	3	17	34	50	16-14 TL-S	16-14 TL-SS
20	3/4	7	20	41	102	20-12 TL-S	20-12 TL-SS
20	1	7	21	41	79	20-16 TL-S	20-16 TL-SS
24	1	7	21	49	141	24-16 TL-S	24-16 TL-SS
24	1 1/4	7	21	49	107	24-20 TL-S	24-20 TL-SS

Part numbers shown are part of our current manufacturing programme.

HMLO Union

O-Lok® ORFS tube ends
SAE 520101

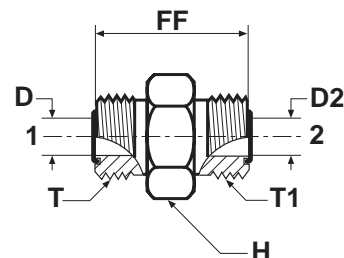

Tube 1 O.D.		Tube 2 O.D.		Thread UN/UNF-2A T	Thread UN/UNF-2A T1	D	D2	FF	H	Weight (steel) g/1 piece	O-Lok® Steel	O-Lok® Stainless Steel	PN (bar)
mm	in.	mm	in.			mm	mm	mm	mm				
6	1/4	6	1/4	9/16-18	9/16-18	5	5	27	16	26	4 HLO-S	4HMLOSS	630
8, 10	5/16, 3/8	8, 10	5/16, 3/8	11/16-16	11/16-16	7	7	31	19	49	6HMLOS	6HMLOSS	630
10	3/8	6	1/4	11/16-16	9/16-18	7	5	30	19	45	6-4HMLOS	6-4HMLOSS	630
12	1/2	12	1/2	13/16-16	13/16-16	10	10	35	22	77	8HMLOS	8HMLOSS	630
12	1/2	10	3/8	13/16-16	11/16-16	10	7	34	22	67	8-6 HLO-S	8-6HMLOSS	630
14, 15, 16	5/8	14, 15, 16	5/8	1-14	1-14	13	13	43	27	129	10HMLOS	10HMLOSS	420
16	5/8	12	1/2	1-14	13/16-16	13	10	40	27	112	10-8 HLO-S	10-8HMLOSS	420
18, 20	3/4	18, 20	3/4	1 3/16-12	1 3/16-12	16	16	47	32	204	12HMLOS	12HMLOSS	420
20	3/4	16	5/8	1 3/16-12	1-14	16	13	46	32	186	12-10HMLOS	12-10HMLOSS	420
22, 25	1	22, 25	1	1 7/16-12	1 7/16-12	21	21	49	38	291	16HMLOS	16HMLOSS	420
25	1	18, 20	3/4	1 7/16-12	1 3/16-12	21	16	49	41	285	16-12HMLOS	16-12HMLOSS	420
28, 30, 32	1 1/4	28, 30, 32	1 1/4	1 11/16-12	1 11/16-12	26	26	51	46	299	20 HLO-S	20HMLOSS	420
28, 30, 32	1 1/4	22, 25	1	1 11/16-12	1 7/16-12	26	21	51	46	280	20-16HMLOS	20-16HMLOSS	420
35, 38	1 1/2	35, 38	1 1/2	2-12	2-12	32	32	53	55	552	24 HLO-S	24HMLOSS	350
35, 38	1 1/2	28, 30, 32	1 1/4	2-12	1 11/16-12	32	26	53	55	530	24-20HMLOS	24-20HMLOSS	350
50	2	50	2	2 1/2-12	2 1/2-12	45	45	73	70	990	32 HLO-S	32HMLOSS	200

O-Lok® is delivered with NBR elastomeric seals as standard. For more details on other seal materials see page J73-J74.

Part numbers shown are part of our current manufacturing programme.

Imperial and metric parts may vary in hexagon dimensions.

$$\frac{\text{PN (bar)}}{10} = \text{PN (MPa)}$$

Pressure ratings – PN shown, apply to Steel and Stainless Steel versions of the product.



EMLO Union elbow

O-Lok® ORFS tube ends
SAE 520201

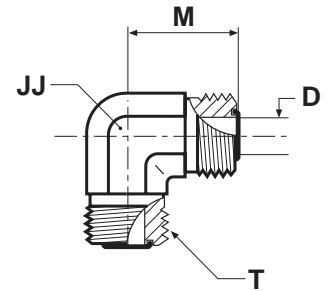

Tube O.D.		Thread UN/UNF-2A T	D mm	JJ mm	M mm	Weight (steel) g/1 piece	O-Lok® Steel	O-Lok® Stainless Steel	PN (bar)
mm	in.								
6	1/4	9/16-18	5	14	22	47	4 ELO-S	4EMLOSS	630
8, 10	5/16, 3/8	11/16-16	7	19	25	109	6 ELO-S	6EMLOSS	630
12	1/2	13/16-16	10	19	28	123	8 ELO-S	8EMLOSS	630
14, 15, 16	5/8	1-14	13	27	33	183	10 ELO-S	10EMLOSS	420
18, 20	3/4	1 3/16-12	16	30	37	255	12 ELO-S	12EMLOSS	420
22, 25	1	1 7/16-12	21	37	42	457	16 ELO-S	16EMLOSS	420
28, 30, 32	1 1/4	1 11/16-12	26	41	45	530	20 ELO-S	20EMLOSS	350
35, 38	1 1/2	2-12	32	48	49	687	24 ELO-S	24EMLOSS	280
50	2	2 1/2-12	45	64	70	1500	32 ELO-S		200

O-Lok® is delivered with NBR elastomeric seals as standard. For more details on other seal materials see page J73–J74.

Part numbers shown are part of our current manufacturing programme.

Imperial and metric parts may vary in hexagon dimensions.

$$\frac{\text{PN (bar)}}{10} = \text{PN (MPa)}$$

Pressure ratings – PN shown, apply to Steel and Stainless Steel versions of the product.

JMLO Union tee

O-Lok® ORFS tube ends
SAE 520401

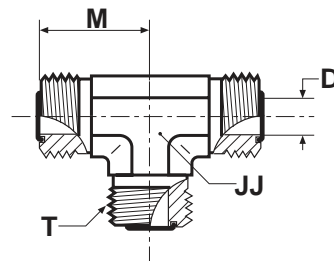

Tube O.D.		Thread UN/UNF-2A T	D mm	JJ mm	M mm	Weight (steel) g/1 piece	O-Lok® Steel	O-Lok® Stainless Steel	PN (bar)
mm	in.								
6	1/4	9/16-18	5	14	22	66	4JMLOS	4JMLOSS	630
8, 10	5/16, 3/8	11/16-16	7	19	25	114	6JMLOS	6JMLOSS	630
12	1/2	13/16-16	10	19	28	199	8JMLOS	8JMLOSS	630
14, 15, 16	5/8	1-14	13	27	33	239	10JMLOS	10JMLOSS	420
18, 20	3/4	1 3/16-12	16	30	37	321	12JMLOS	12JMLOSS	420
22, 25	1	1 7/16-12	21	36	42	488	16JMLOS	16JMLOSS	420
28, 30, 32	1 1/4	1 11/16-12	26	41	45	768	20 JLO-S	20JMLOSS	350
35, 38	1 1/2	2-12	32	48	49	866	24 JLO-S	24JMLOSS	280
50	2	2 1/2-12	45	64	70	2250	32 JLO-S	32JMLOSS	200

O-Lok® is delivered with NBR elastomeric seals as standard. For more details on other seal materials see page J73–J74.

Part numbers shown are part of our current manufacturing programme.

Imperial and metric parts may vary in hexagon dimensions.

$$\frac{\text{PN (bar)}}{10} = \text{PN (MPa)}$$

Pressure ratings – PN shown, apply to Steel and Stainless Steel versions of the product.

J

KLO Union cross

O-Lok® ORFS tube ends
SAE 520501

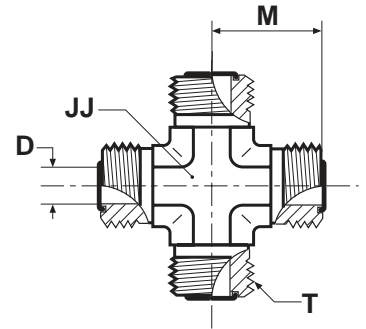

Tube O.D.		Thread UN/UNF-2A T	D mm	JJ mm	M mm	Weight (steel) g/1 piece	O-Lok® Steel	O-Lok® Stainless Steel	PN (bar)
mm	in.								
6	1/4	9/16-18	5	14	22	72	4 KLO-S	4 KLO-SS	630
8, 10	5/16, 3/8	11/16-16	7	19	25	140	6 KLO-S	6 KLO-SS	630
12	1/2	13/16-16	10	19	28	225	8 KLO-S	8 KLO-SS	630
14, 15, 16	5/8	1-14	13	27	33	288	10 KLO-S	10 KLO-SS	420
18, 20	3/4	1 3/16-12	16	30	37	415	12 KLO-S	12 KLO-SS	420
22, 25	1	1 7/16-12	21	37	42	967	16 KLO-S	16 KLO-SS	420
28, 30, 32	1 1/4	1 11/16-12	26	41	45	1247	20 KLO-S	20 KLO-SS	350
35, 38	1 1/2	2-12	32	48	49	1592	24 KLO-S	24 KLO-SS	280

O-Lok® is delivered with NBR elastomeric seals as standard. For more details on other seal materials see page J73–J74.

Part numbers shown are part of our current manufacturing programme.

Imperial and metric parts may vary in hexagon dimensions.

$$\frac{\text{PN (bar)}}{10} = \text{PN (MPa)}$$

Pressure ratings – PN shown, apply to Steel and Stainless Steel versions of the product.

WMLO Bulkhead union

O-Lok® ORFS tube ends
SAE 520601 ISO 8434-3 BHS

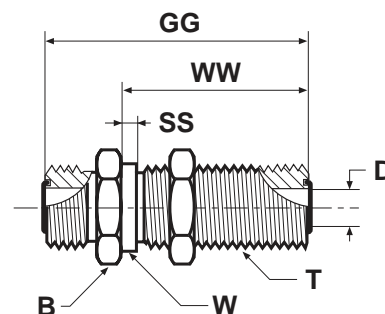

Tube O.D.		Thread UN/UNF-2A T	B mm	D mm	GG mm	SS mm	W mm	WW mm	Weight (steel) g/1 piece	O-Lok® Steel	O-Lok® Stainless Steel	PN (bar)
mm	in.											
6	1/4	9/16-18	22	5	49	2	14	32	65	4 WLO-WLNL-S	4WMLOWLNMLSS	630
8, 10	5/16, 3/8	11/16-16	27	7	53	2	17	34	104	6WMLOWLNMLS	6WMLOWLNMLSS	630
12	1/2	13/16-16	30	10	58	3	20	37	141	8WMLOWLNMLS	8WMLOWLNMLSS	630
14, 15, 16	5/8	1-14	32	13	67	3	25	41	285	10WMLOWLNMLS	10WMLOWLNMLSS	420
18, 20	3/4	1 3/16-12	38	16	69	3	30	42	322	12WMLOWLNMLS	12WMLOWLNMLSS	420
22, 25	1	1 7/16-12	46	21	70	3	36	42	436	16WMLOWLNMLS	16WMLOWLNMLSS	420
28, 30, 32	1 1/4	1 11/16-12	51	26	70	2	43	42	510	20 WLO-WLNL-S	20WMLOWLNMLSS	420
35, 38	1 1/2	2-12	60	32	70	2	51	42	674	24 WLO-WLNL-S	24WMLOWLNMLSS	350

O-Lok® is delivered with NBR elastomeric seals as standard. For more details on other seal materials see page J73–J74.

Part numbers shown are part of our current manufacturing programme.

Imperial and metric parts may vary in hexagon dimensions.

For the version without the locknut remove "WLNL" (e.g. 16WMLO)

$$\frac{\text{PN (bar)}}{10} = \text{PN (MPa)}$$

Pressure ratings – PN shown, apply to Steel and Stainless Steel versions of the product.

Maximum bulkhead wallthickness

Size	Tube O.D.		Straight bulkhead union Max. thickness mm	Shape bulkhead union Max. thickness mm
	inch	metric		
4	1/4	6	13.5	13.5
6	3/8	10	13.5	13.5
8	1/2	12	13.5	13.5
10	5/8	14–16	13.2	13.2
12	3/4	18–20	12.7	12.7
16	1	22–25	13.0	13.0
20	1 1/4	28–32	13.0	13.0
24	1 1/2	35–38	13.0	13.0



WEMLO Bulkhead union elbow

O-Lok® ORFS tube end/O-Lok® ORFS tube end
SAE520701/SAE 520701 ISO 8434-3 BHE

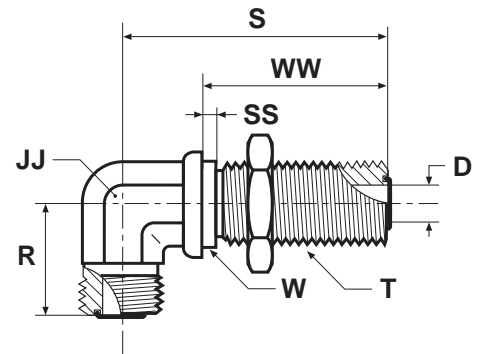

Tube O.D.		Thread UN/UNF-2A T	D mm	JJ mm	R mm	S mm	SS mm	W mm	WW mm	Weight (steel) g/1 piece	O-Lok® Steel	O-Lok® Stainless Steel	PN (bar)
mm	in.												
6	1/4	9/16-18	5	14	23	46	2	14	32	78	4 WELO-WLNL-S	4 WELO-WLNL-SS	630
8, 10	5/16, 3/8	11/16-16	7	19	26	52	2	17	34	146	6WEMLOWLNMLS	6 WELO-WLNL-SS	630
12	1/2	13/16-16	10	19	29	56	3	20	37	252	8WEMLOWLNMLS	8 WELO-WLNL-SS	630
14, 15, 16	5/8	1-14	13	27	35	63	3	25	41	287	10WEMLOWLNMLS	10 WELO-WLNL-SS	420
18, 20	3/4	1 3/16-12	16	30	39	67	3	30	42	445	12WEMLOWLNMLS	12 WELO-WLNL-SS	420
22, 25	1	1 7/16-12	21	37	42	71	2	37	42	639	16 WELO-WLNL-S	16 WELO-WLNL-SS	420
28, 30, 32	1 1/4	1 11/16-12	26	41	45	75	2	43	42	718	20 WELO-WLNL-S	20 WELO-WLNL-SS	350
35, 38	1 1/2	2-12	32	48	50	80	2	51	42	945	24 WELO-WLNL-S	24 WELO-WLNL-SS	280

O-Lok® is delivered with NBR elastomeric seals as standard. For more details on other seal materials see page J73-J74.

Part numbers shown are part of our current manufacturing programme.

Imperial and metric parts may vary in hexagon dimensions.

For the version without the locknut remove "WLNML" (e.g. 16WEMLO)

$$\frac{\text{PN (bar)}}{10} = \text{PN (MPa)}$$

Pressure ratings – PN shown, apply to Steel and Stainless Steel versions of the product.

Maximum bulkhead wallthickness

Size	Tube O.D.		Straight bulkhead union Max. thickness mm	Shape bulkhead union Max. thickness mm
	inch	metric		
4	1/4	6	13.5	13.5
6	3/8	10	13.5	13.5
8	1/2	12	13.5	13.5
10	5/8	14-16	13.2	13.2
12	3/4	18-20	12.7	12.7
16	1	22-25	13.0	13.0
20	1 1/4	28-32	13.0	13.0
24	1 1/2	35-38	13.0	13.0

WNLO Bulkhead union 45° elbow

O-Lok® ORFS tube ends

SAE 520801 ISO 8434-3 BHE 45

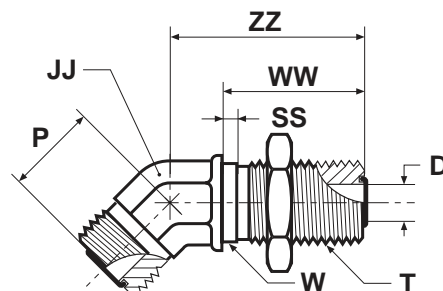

Tube O.D.		Thread UN/UNF-2A T	D mm	JJ mm	P mm	SS mm	W mm	WW mm	ZZ mm	Weight (steel) g/1 piece	O-Lok® Steel	PN (bar)
mm	in.											
6	1/4	9/16-18	5	14	16	2	14	32	44	65	4 WNLO-WLNL-S	630
8, 10	5/16, 3/8	11/16-16	7	19	19	2	18	34	49	123	6 WNLO-WLNL-S	630
12	1/2	13/16-16	10	19	20	2	21	37	51	163	8 WNLO-WLNL-S	630
14, 15, 16	5/8	1-14	13	27	23	2	25	41	57	252	10 WNLO-WLNL-S	420
18, 20	3/4	1 3/16-12	16	30	26	2	30	42	61	386	12 WNLO-WLNL-S	420
22, 25	1	1 7/16-12	21	37	30	2	37	42	65	465	16 WNLO-WLNL-S	420
28, 30, 32	1 1/4	1 11/16-12	26	41	32	2	43	42	67	578	20 WNLO-WLNL-S	350
35, 38	1 1/2	2-12	32	48	37	2	51	42	67	770	24 WNLO-WLNL-S	280

O-Lok® is delivered with NBR elastomeric seals as standard. For more details on other seal materials see page J73–J74.

Part numbers shown are part of our current manufacturing programme.

Imperial and metric parts may vary in hexagon dimensions.

For the version without the locknut remove "WLNL" (e.g. 16 WNLO)

$$\frac{\text{PN (bar)}}{10} = \text{PN (MPa)}$$



Maximum bulkhead wallthickness

Size	Tube O.D.		Straight bulkhead union Max. thickness mm	Shape bulkhead union Max. thickness mm
	inch	metric		
4	1/4	6	13.5	13.5
6	3/8	10	13.5	13.5
8	1/2	12	13.5	13.5
10	5/8	14–16	13.2	13.2
12	3/4	18–20	12.7	12.7
16	1	22–25	13.0	13.0
20	1 1/4	28–32	13.0	13.0
24	1 1/2	35–38	13.0	13.0

WJLO Bulkhead branch tee

O-Lok® ORFS tube ends

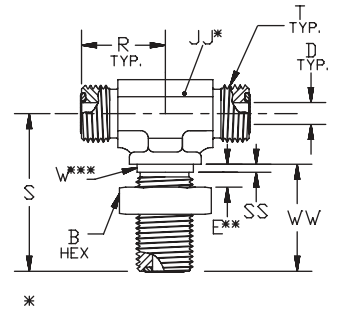

Tube O.D.		Thread UN/UNF-2A mm	B mm	D mm	E mm	JJ mm	R mm	S mm	SS mm	W mm	WW mm	Weight (steel) g/1 piece	O-Lok® Steel	PN (bar)
mm	in.													
6	1/4	9/16-18	18	5	14	14	23	47	2	14	32	100	4 WJLO-WLNL-S	630
8, 10	5/16, 3/8	11/16-16	21	7	14	19	26	52	2	18	34	178	6 WJLO-WLNL-S	630
12	1/2	13/16-16	24	10	14	19	29	55	2	21	37	270	8 WJLO-WLNL-S	630
14, 15, 16	5/8	1-14	29	13	14	27	35	63	2	25	41	370	10 WJLO-WLNL-S	420
18, 20	3/4	1 3/16-12	35	16	14	30	39	67	2	30	42	520	12 WJLO-WLNL-S	420
22, 25	1	1 7/16-12	42	21	14	36	42	71	2	37	42	680	16 WJLO-WLNL-S	420

O-Lok® is delivered with NBR elastomeric seals as standard. For more details on other seal materials see page J73–J74.

Part numbers shown are part of our current manufacturing programme.

Imperial and metric parts may vary in hexagon dimensions.

For the version without the locknut remove "WLNL" (e.g. 16 WJLO)

$$\frac{\text{PN (bar)}}{10} = \text{PN (MPa)}$$

Maximum bulkhead wallthickness

Size	Tube O.D.		Straight bulkhead union Max. thickness mm	Shape bulkhead union Max. thickness mm
	inch	metric		
4	1/4	6	13.5	13.5
6	3/8	10	13.5	13.5
8	1/2	12	13.5	13.5
10	5/8	14–16	13.2	13.2
12	3/4	18–20	12.7	12.7
16	1	22–25	13.0	13.0
20	1 1/4	28–32	13.0	13.0
24	1 1/2	35–38	13.0	13.0

WJJLO Bulkhead run tee

O-Lok® ORFS tube ends
SAE 520958 ISO 8434-3 BHRT

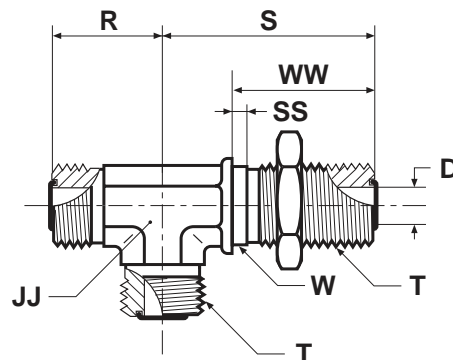

Tube O.D.		Thread UN/UNF-2A T	D mm	JJ mm	R mm	S mm	SS mm	W mm	WW mm	Weight (steel) g/1 piece	O-Lok® Steel	PN (bar)
mm	in.											
6	1/4	9/16-18	5	14	23	46	2	14	32	99	4 WJJLO-WLNL-S	630
8, 10	5/16, 3/8	11/16-16	7	19	26	52	2	18	34	178	6 WJJLO-WLNL-S	630
12	1/2	13/16-16	10	19	29	55	2	21	36	270	8 WJJLO-WLNL-S	630
14, 15, 16	5/8	1-14	13	27	35	63	2	25	41	368	10 WJJLO-WLNL-S	420
18, 20	3/4	1 3/16-12	16	30	39	67	2	30	42	516	12 WJJLO-WLNL-S	420
22, 25	1	1 7/16-12	21	37	42	71	2	37	42	678	16 WJJLO-WLNL-S	420
28, 30, 32	1 1/4	1 11/16-12	26	41	45	75	2	43	42	980	20 WJJLO-WLNL-S	350
35, 38	1 1/2	2-12	32	48	50	80	2	51	42	1900	24 WJJLO-WLNL-S	280

O-Lok® is delivered with NBR elastomeric seals as standard. For more details on other seal materials see page J73–J74.

Part numbers shown are part of our current manufacturing programme.

Imperial and metric parts may vary in hexagon dimensions.

For the version without the locknut remove "WLNL" (e.g. 16 WJJLO)

$$\frac{\text{PN (bar)}}{10} = \text{PN (MPa)}$$

Maximum bulkhead wallthickness

Size	Tube O.D.		Straight bulkhead union Max. thickness mm	Shape bulkhead union Max. thickness mm
	inch	metric		
4	1/4	6	13.5	13.5
6	3/8	10	13.5	13.5
8	1/2	12	13.5	13.5
10	5/8	14–16	13.2	13.2
12	3/4	18–20	12.7	12.7
16	1	22–25	13.0	13.0
20	1 1/4	28–32	13.0	13.0
24	1 1/2	35–38	13.0	13.0

AOEL6 Swivel nut stud elbow

O-Lok® ORFS Female swivel end/Male UN/UNF thread – O-ring (ISO 11926)
SAE 520281

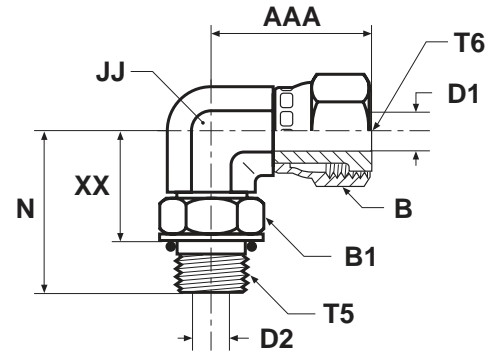

Tube O.D. mm	Tube O.D. in.	Thread UN/UNF-2A T5	Thread UN/UNF-2B T6	AAA mm	B mm	B1 mm	D1 mm	D2 mm	JJ mm	N mm	XX mm	Weight (steel) g/1 piece	O-Lok® Steel	O-Lok® Stainless Steel	PN (bar)
6	1/4	7/16-20	9/16-18	27	18	16	4	4	14	33	22	47	4 AOEL6-S	4 AOEL6-SS	420
8, 10	5/16, 3/8	9/16-18	11/16-16	30	21	19	7	7	19	37	25	97	6 AOEL6-S	6 AOEL6-SS	420
12	1/2	3/4-16	13/16-16	38	24	24	9	10	19	41	27	104	8 AOEL6-S	8 AOEL6-SS	420
14, 15, 16	5/8	7/8-14	1-14	42	29	27	12	13	27	50	34	199	10 AOEL6-S	10 AOEL6-SS	420
18, 20	3/4	1 1/16-12	1 3/16-12	46	35	35	14	16	27	55	37	162	12 AOEL6-S	12 AOEL6-SS	420
22, 25	1	1 5/16-12	1 7/16-12	53	41	41	20	21	33	60	42	365	16 AOEL6-S	16 AOEL6-SS	380
28, 30, 32	1 1/4	1 5/8-12	1 11/16-12	58	48	48	26	26	41	62	44	480	20 AOEL6-S	20 AOEL6-SS	280
35, 38	1 1/2	1 7/8-12	2-12	61	57	54	32	32	48	66	47	933	24 AOEL6-S	24 AOEL6-SS	280

O-Lok® is delivered with NBR elastomeric seals as standard. For more details on other seal materials see page J73–J74.

Part numbers shown are part of our current manufacturing programme.

Imperial and metric parts may vary in hexagon dimensions.

$$\frac{\text{PN (bar)}}{10} = \text{PN (MPa)}$$

Pressure ratings – PN shown, apply to Steel and Stainless Steel versions of the product.

C6MLO Swivel nut elbow

O-Lok® ORFS Female swivel end/O-Lok® ORFS tube end
SAE 52M0221 ISO 8434-3 SWE

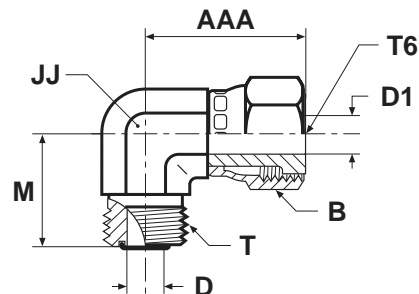

Tube O.D.		Thread UN/UNF-2A T	Thread UN/UNF-2B T6	AAA	B	D	D1	JJ	M	Weight (steel)	O-Lok® Steel	O-Lok® Stainless Steel	PN (bar)
mm	in.			mm	mm	mm	mm	mm	mm	g/1 piece			
6	1/4	9/16-18	9/16-18	26	17	5	4	14	22	45	4C6MLOS	4C6MLOSS	500
8, 10	5/16, 3/8	11/16-16	11/16-16	29	22	7	9	19	25	84	6C6MLOS	6C6MLOSS	630
12	1/2	13/16-16	13/16-16	38	24	10	9	19	28	126	8C6MLOS	8C6MLOSS	630
14, 15, 16	5/8	1-14	1-14	41	30	13	12	27	33	221	10C6MLOS	10C6MLOSS	420
18, 20	3/4	1 3/16-12	1 3/16-12	46	36	16	14	30	37	284	12C6MLOS	12C6MLOSS	420
22, 25	1	1 7/16-12	1 7/16-12	53	41	21	20	36	42	541	16C6MLOS	16C6MLOSS	420
28, 30, 32	1 1/4	1 11/16-12	1 11/16-12	58	48	26	26	41	45	557	20 C6LO-S	20C6MLOSS	350
35, 38	1 1/2	2-12	2-12	61	57	32	32	48	49	706	24 C6LO-S	24C6MLOSS	280

O-Lok® is delivered with NBR elastomeric seals as standard. For more details on other seal materials see page J73–J74.

Part numbers shown are part of our current manufacturing programme.

Imperial and metric parts may vary in hexagon dimensions.

$$\frac{\text{PN (bar)}}{10} = \text{PN (MPa)}$$

Pressure ratings – PN shown, apply to Steel and Stainless Steel versions of the product.



V6LO 45° Swivel nut elbow

O-Lok® ORFS female swivel end/O-Lok® ORFS tube end

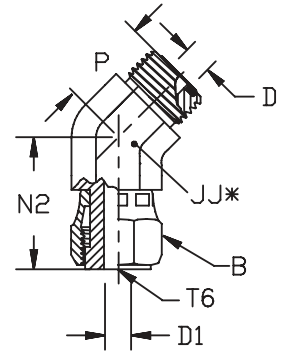

*JJ – Across wrench flats

Tube O.D.		Thread UN/UNF-2A T	Thread UN/UNF-2B T6	B mm	D mm	D1 mm	JJ mm	N2 mm	P mm	Weight (steel) g/1 piece	O-Lok® Steel	PN (bar)
mm	in.											
6	1/4	9/16-18	9/16-18	18	5	4	14	25	16	44	4 V6LO-S	500
8, 10	5/16, 3/8	11/16-16	11/16-16	21	7	7	19	28	19	82	6 V6LO-S	630
12	1/2	13/16-16	13/16-16	24	10	9	19	38	20	110	8 V6LO-S	630
14, 15, 16	5/8	1-14	1-14	29	13	12	27	39	23	190	10 V6LO-S	420
18, 20	3/4	1 3/16-12	1 3/16-12	35	16	14	30	44	26	288	12 V6LO-S	420
22, 25	1	1 7/16-12	1 7/16-12	42	21	20	36	48	30	300	16 V6LO-S	420
28, 30, 32	1 1/4	1 11/16-12	1 11/16-12	48	26	26	41	50	32	444	20 V6LO-S	350
35, 38	1 1/2	2-12	2-12	58	32	32	48	52	37	568	24 V6LO-S	280

O-Lok® is delivered with NBR elastomeric seals as standard. For more details on other seal materials see page J73–J74.

Part numbers shown are part of our current manufacturing programme.

Imperial and metric parts may vary in hexagon dimensions.

$$\frac{\text{PN (bar)}}{10} = \text{PN (MPa)}$$

S6MLO Swivel nut branch tee

O-Lok® ORFS female swivel end/O-Lok® ORFS tube ends
SAE 52M0433 ISO 8434-3 SWBT

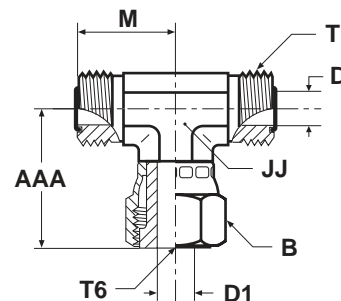

Tube O.D.		Thread UN/UNF-2A T	Thread UN/UNF-2B T6	AAA	B	D	D1	JJ	M	Weight (steel)	O-Lok® Steel	O-Lok® Stainless Steel	PN (bar)
mm	in.			mm	mm	mm	mm	mm	mm	g/1 piece			
6	1/4	9/16-18	9/16-18	26	17	5	4	14	22	66	4S6MLOS	4S6MLOSS	500
8, 10	5/16, 3/8	11/16-16	11/16-16	29	22	7	7	19	25	125	6S6MLOS	6S6MLOSS	630
12	1/2	13/16-16	13/16-16	38	24	10	9	19	28	150	8S6MLOS	8S6MLOSS	630
14, 15, 16	5/8	1-14	1-14	41	30	13	12	27	33	233	10S6MLOS	10S6MLOSS	420
18, 20	3/4	1 3/16-12	1 3/16-12	46	35	16	14	30	37	383	12 S6LO-S	12S6MLOSS	420
22, 25	1	1 7/16-12	1 7/16-12	53	41	21	20	37	42	518	16 S6LO-S	16S6MLOSS	420
28, 30, 32	1 1/4	1 11/16-12	1 11/16-12	58	48	26	26	41	45	775	20 S6LO-S	20S6MLOSS	350
35, 38	1 1/2	2-12	2-12	61	57	32	32	48	49	933	24 S6LO-S	24S6MLOSS	280

O-Lok® is delivered with NBR elastomeric seals as standard. For more details on other seal materials see page J73–J74.

Part numbers shown are part of our current manufacturing programme.

Imperial and metric parts may vary in hexagon dimensions.

$$\frac{\text{PN (bar)}}{10} = \text{PN (MPa)}$$

Pressure ratings – PN shown, apply to Steel and Stainless Steel versions of the product.



R6MLO Swivel nut run tee

O-Lok® ORFS female swivel end/O-Lok® ORFS tube ends
 SAE 52M0432 ISO 8434-3 SWRT

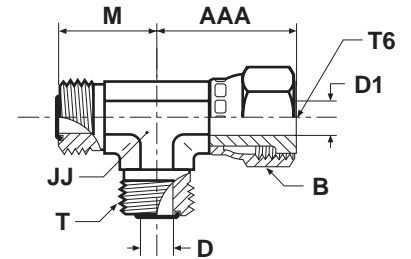

Tube O.D.		Thread UN/UNF-2A T	Thread UN/UNF-2B T6	AAA	B	D	D1	JJ	M	Weight (steel)	O-Lok® Steel	O-Lok® Stainless Steel	PN (bar)
mm	in.			mm	mm	mm	mm	mm	mm	g/1 piece			
6	1/4	9/16-18	9/16-18	26	17	5	4	14	22	66	4R6MLOS	4R6MLOSS	500
8, 10	5/16, 3/8	11/16-16	11/16-16	29	22	7	7	19	25	125	6R6MLOS	6R6MLOSS	630
12	1/2	13/16-16	13/16-16	38	24	10	9	19	28	150	8R6MLOS	8R6MLOSS	630
14, 15, 16	5/8	1-14	1-14	41	30	13	12	27	33	233	10R6MLOS	10R6MLOSS	420
18, 20	3/4	1 3/16-12	1 3/16-12	46	35	16	14	30	37	383	12 R6LO-S	12R6MLOSS	420
22, 25	1	1 7/16-12	1 7/16-12	53	41	21	20	37	42	518	16 R6LO-S	16R6MLOSS	420
28, 30, 32	1 1/4	1 11/16-12	1 11/16-12	58	48	26	26	41	45	775	20 R6LO-S	20R6MLOSS	350
35, 38	1 1/2	2-12	2-12	61	57	32	32	48	49	933	24 R6LO-S	24R6MLOSS	280

O-Lok® is delivered with NBR elastomeric seals as standard. For more details on other seal materials see page J73–J74.

Part numbers shown are part of our current manufacturing programme.

Imperial and metric parts may vary in hexagon dimensions.

$$\frac{\text{PN (bar)}}{10} = \text{PN (MPa)}$$

Pressure ratings – PN shown, apply to Steel and Stainless Steel versions of the product.

TRMLO Tube end reducer

O-Lok® ORFS tube end/O-Lok® ORFS swivel female end
SAE 520123 /A

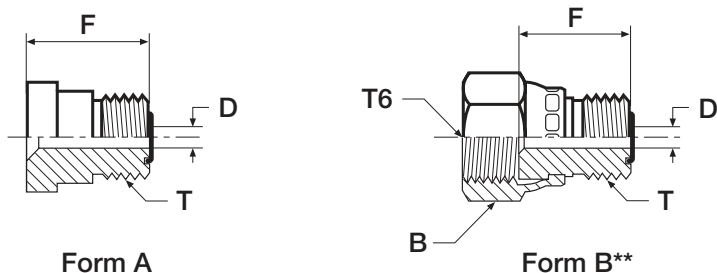

Tube O.D.		Thread UN/UNF-2A T	Thread UN/UNF-2B T6	B mm	D mm	F mm	Weight (steel) g/1 piece	Form	O-Lok® Steel	O-Lok® Stainless Steel	PN (bar)
mm	in.										
10	3/8	9/16-18	11/16-16	21	5	20	21	B	6-4TRMLONS	6-4TRMLONSS	630
12	1/2	9/16-18	—	—	5	22	30	A	8-4 TRLO-S	8-4TRMLOSS	630
12	1/2	11/16-16	13/16-16	24	7	22	33	B	8-6TRMLONS	8-6TRMLONSS	630
16	5/8	9/16-18	—	—	5	23	37	A	10-4 TRLO-S	10-4TRMLOSS	420
16	5/8	11/16-16	—	—	7	24	48	A	10-6 TRLO-S	10-6TRMLOSS	420
16	5/8	13/16-16	—	—	10	26	50	A	10-8 TRLO-S	10-8TRMLOSS	420
20	3/4	9/16-18	—	—	5	25	63	A	12-4 TRLO-S	12-4TRMLOSS	420
20	3/4	11/16-16	—	—	7	26	66	A	12-6 TRLO-S	12-6TRMLOSS	420
20	3/4	13/16-16	—	—	10	28	71	A	12-8 TRLO-S	12-8TRMLOSS	420
20	3/4	1-14	1 3/16-12	36	13	30	85	B	12-10TRMLONS	12-10TRMLONSS	420
25	1	13/16-16	—	—	10	29	103	A	16-8 TRLO-S	16-8TRMLOSS	420
25	1	1-14	—	—	13	32	118	A	16-10 TRLO-S	16-10TRMLOSS	420
25	1	1 3/16-12	1 7/16-12	41	16	33	133	B	16-12 TRLO-S	16-12TRMLONSS	420
32	1 1/4	1 3/16-12	—	—	16	34	169	A	20-12 TRLO-S	20-12TRMLOSS	420
32	1 1/4	1 7/16-12	1 11/16-12	48	21	38	183	B	20-16 TRLO-S	20-16TRMLONSS	350
38	1 1/2	1 7/16-12	—	—	21	31	205	A	24-16 TRLO-S	24-16TRMLOSS	350
38	1 1/2	1 11/16-12	—	—	26	34	209	A	24-20 TRLO-S	24-20TRMLOSS	350
50	2	1 11/16-12	—	—	26	36	420	A	32-20 TRLO-S	32-20TRMLOSS	200
50	2	2-12	—	—	32	36	420	A	32-24 TRLO-S	32-24TRMLOSS	200

O-Lok® is delivered with NBR elastomeric seals as standard. For more details on other seal materials see page J73–J74.

Part numbers shown are part of our current manufacturing programme.

Imperial and metric parts may vary in hexagon dimensions.

$$\frac{\text{PN (bar)}}{10} = \text{PN (MPa)}$$

Pressure ratings – PN shown, apply to Steel and Stainless Steel versions of the product.

**These size come assembled with a crimp style nut (Form B).



LOHL6 Tube end expander

O-Lok® ORFS tube end/O-Lok® ORFS female swivel end

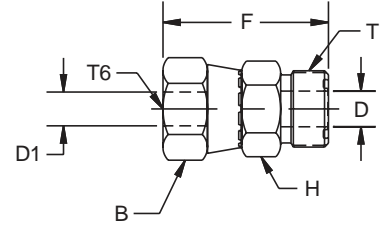

Tube O.D.		Thread UN/UNF-2A T	Thread UN/UNF-2B T6	B mm	D mm	D1 mm	H mm	F mm	Weight (steel) g/1 piece	O-Lok® Steel	PN (bar)
mm	in.										
8, 10	5/16, 3/8	11/16-16	9/16-18	18	7	4	19	35	33	6-4LOHL6	630
12	1/2	13/16-16	11/16-16	21	10	7	22	39	52	8-6LOHL6	630
14, 15, 16	5/8	1-14	13/16-16	24	13	9	27	46	92	10-8LOHL6	420
18, 20	3/4	1 3/16-12	1-14	29	16	12	32	51	146	12-10LOHL6	420
22, 25	1	1 7/16-12	1 3/16-12	35	21	14	41	55	205	16-12LOHL6	420
28, 30, 32	1 1/4	1 11/16-12	1 7/16-12	42	26	20	46	58	260	20-16LOHL6	350
35, 38	1 1/2	2-12	1 11/16-12	48	26	26	55	60	315	24-20LOHL6	280

O-Lok® is delivered with NBR elastomeric seals as standard. For more details on other seal materials see page J73–J74.

Part numbers shown are part of our current manufacturing programme.

Imperial and metric parts may vary in hexagon dimensions.

$$\frac{\text{PN (bar)}}{10} = \text{PN (MPa)}$$

HL6 Swivel nut union

O-Lok® ORFS female swivel ends

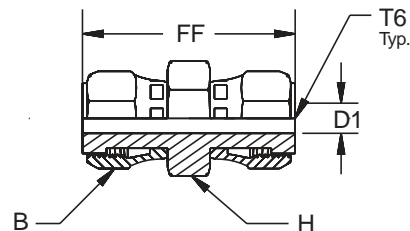

mm	Tube O.D. in.	Thread UN/UNF-2B T6	B mm	D1 mm	FF mm	H mm	Weight (steel) g/1 piece	O-Lok® Steel	PN (bar)
6	1/4	9/16-18	18	4.0	40.4	17	53	4 HL6-S	500
8, 10	5/16, 3/8	11/16-16	21	6.5	45.0	19	66	6 HL6-S	630
12	1/2	13/16-16	24	9.0	53.8	22	110	8 HL6-S	630
14, 15, 16	5/8	1-14	29	11.5	61.5	27	173	10 HL6-S	420
18, 20	3/4	1 3/16-12	35	14.0	69.6	32	275	12 HL6-S	420

Part numbers shown are part of our current manufacturing programme.

Imperial and metric parts may vary in hexagon dimensions.

$$\frac{\text{PN (bar)}}{10} = \text{PN (MPa)}$$



F87OMLO Male stud connector

O-Lok® ORFS tube end /Male metric thread – O-ring (ISO 6149-2)
SAE 52M0187 ISO 8434-3 SDS

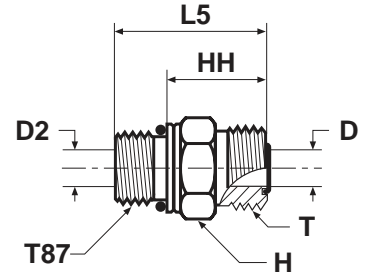

Tube O.D.		Thread metric T87	Thread UN/UNF-2A T	D mm	D2 mm	H mm	HH mm	L5 mm	Weight (steel) g/1 piece	O-Lok®		PN (bar)
mm	in.									Steel	Stainless Steel	
6	1/4	M10 1.0	9/16-18	5	3	17	18	27	20	4M10F87OMLOS	4M10F87OMLOSS	630
6	1/4	M12 1.5	9/16-18	5	4	17	18	29	24	4M12F87OMLOS	4M12F87OMLOSS	630
6	1/4	M14 1.5	9/16-18	5	5	19	19	30	30	4M14F87OMLOS	4M14F87OMLOSS	630
8, 10	5/16, 3/8	M12 1.5	11/16-16	6	4	19	23	34	40	6M12F87OMLOS	6M12F87OMLOSS	630
8, 10	5/16, 3/8	M14 1.5	11/16-16	7	6	19	20	31	43	6M14F87OMLOS	6M14F87OMLOSS	630
8, 10	5/16, 3/8	M16 1.5	11/16-16	7	7	22	21	34	43	6M16F87OMLOS	6M16F87OMLOSS	630
8, 10	5/16, 3/8	M18 1.5	11/16-16	7	7	24	21	35	45	6M18F87OMLOS	6M18F87OMLOSS	630
8, 10	5/16, 3/8	M22 1.5	11/16-16	7	7	27	23	38	52	6M22F87OMLOS	6M22F87OMLOSS	420
12	1/2	M14 1.5	13/16-16	10	6	22	24	35	40	8M14F87OMLOS	8M14F87OMLOSS	630
12	1/2	M16 1.5	13/16-16	10	7	24	24	37	58	8M16F87OMLOS	8M16F87OMLOSS	630
12	1/2	M18 1.5	13/16-16	10	9	24	23	37	55	8M18F87OMLOS	8M18F87OMLOSS	630
12	1/2	M22 1.5	13/16-16	10	10	27	24	39	60	8M22F87OMLOS	8M22F87OMLOSS	420
12	1/2	M27 2	13/16-16	10	10	32	26	44	70	8M27F87OMLOS	8M27F87OMLOSS	420
14, 15, 16	5/8	M18 1.5	1-14	13	9	27	27	41	120	10M18F87OMLOS	10M18F87OMLOSS	420
14, 15, 16	5/8	M22 1.5	1-14	13	12	27	27	42	127	10M22F87OMLOS	10M22F87OMLOSS	420
18, 20	3/4	M22 1.5	1 3/16-12	16	12	32	35	50	170	12M22F87OMLOS	12M22F87OMLOSS	420
18, 20	3/4	M27 2	1 3/16-12	16	15	32	30	49	187	12M27F87OMLOS	12M27F87OMLOSS	420
18, 20	3/4	M33 2	1 3/16-12	16	16	41	31	50	200	12M33F87OMLOS	12M33F87OMLOSS	420
22, 25	1	M27 2	1 7/16-12	21	15	41	36	54	230	16M27F87OMLOS	16M27F87OMLOSS	420
22, 25	1	M33 2	1 7/16-12	21	20	41	34	52	270	16M33F87OMLOS	16M33F87OMLOSS	420
28, 30, 32	1 1/4	M33 2	1 11/16-12	26	20	46	36	54	370	20M33F87OMLOS	20M33F87OMLOSS	420
28, 30, 32	1 1/4	M42 2	1 11/16-12	26	26	50	36	55	390	20M42F87OMLOS	20M42F87OMLOSS	420
35, 38	1 1/2	M42 2	2-12	32	26	55	41	60	400	24M42F87OMLOS	24M42F87OMLOSS	350
35, 38	1 1/2	M48 2	2-12	32	32	55	36	57	412	24M48F87OMLOS	24M48F87OMLOSS	350
50	2	M60 2	2 1/2-12	40	40	65	41	65	800	32M60F87OMLOS	32M60F87OMLOSS	200

O-Lok® is delivered with NBR elastomeric seals as standard. For more details on other seal materials see page J73-J74.

Part numbers shown are part of our current manufacturing programme.

Imperial and metric parts may vary in hexagon dimensions.

$$\frac{\text{PN (bar)}}{10} = \text{PN (MPa)}$$

Pressure ratings – PN shown, apply to Steel and Stainless Steel versions of the product.

F5OMLO Male stud connector

O-Lok® ORFS tube end /Male UN/UNF thread – O-ring (ISO 11926)
SAE 520120

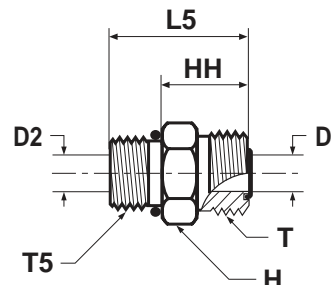

Tube O.D.		Thread UN/UNF-2A T5	Thread UN/UNF-2A T	D	D2	H	HH	L5	Weight (steel) g/1 piece	O-Lok® Steel	O-Lok® Stainless Steel	PN (bar)
mm	in.			mm	mm	mm	mm	mm				
6	1/4	7/16-20	9/16-18	5	5	17	18	29	21	4F5OMLOS	4F5OMLOSS	630
6	1/4	1/2-20	9/16-18	5	6	10	19	29	30	4-5 F5OLO-S	4-5F5OMLOSS	630
6	1/4	9/16-18	9/16-18	5	5	19	19	31	36	4-6F5OMLOS	4-6F5OMLOSS	630
6	1/4	3/4-16	9/16-18	5	5	22	20	34	67	4-8 F5OLO-S	4-8F5OMLOSS	630
8, 10	5/16, 3/8	9/16-18	11/16-16	7	7	19	20	32	45	6F5OMLOS	6F5OMLOSS	630
8, 10	5/16, 3/8	7/16-20	11/16-16	7	5	19	23	34	47	6-4F5OMLOS	6-4F5OMLOSS	630
8, 10	5/16, 3/8	1/2-20	11/16-16	7	6	19	21	31	50	6-5 F5OLO-S	6-5F5OMLOSS	630
8, 10	5/16, 3/8	3/4-16	11/16-16	7	7	22	21	35	51	6-8F5OMLOS	6-8F5OMLOSS	630
8, 10	5/16, 3/8	7/8-14	11/16-16	7	7	27	23	39	89	6-10F5OMLOS	6-10F5OMLOSS	420
10	1/2	3/4-16	13/16-16	10	10	22	23	37	56	8F5OMLOS	8F5OMLOSS	630
12	1/2	9/16-18	13/16-16	10	8	22	26	38	69	8-6F5OMLOS	8-6F5OMLOSS	630
12	1/2	7/8-14	13/16-16	10	10	27	24	40	105	8-10F5OMLOS	8-10F5OMLOSS	420
12	1/2	1 1/16-12	13/16-16	10	10	32	26	44	169	8-12F5OMLOS	8-12F5OMLOSS	420
12	1/2	1 5/16-12	13/16-16	10	10	38	27	46	227	8-16F5OMLOS	8-16F5OMLOSS	420
14, 15, 16	5/8	7/8-14	1-14	13	13	27	27	43	137	10F5OMLOS	10F5OMLOSS	420
14, 15, 16	5/8	3/4-16	1-14	13	10	27	31	45	120	10-8F5OMLOS	10-8F5OMLOSS	420
14, 15, 16	5/8	1 1/16-12	1-14	13	13	32	29	47	170	10-12F5OMLOS	10-12F5OMLOSS	420
18, 20	3/4	1 1/16-12	1 3/16-12	16	16	32	30	49	189	12F5OMLOS	12F5OMLOSS	420
18, 20	3/4	3/4-16	1 3/16-12	16	10	32	35	49	167	12-8 F5OLO-S	12-8F5OMLOSS	420
18, 20	3/4	7/8-14	1 3/16-12	16	13	32	35	51	177	12-10F5OMLOS	12-10F5OMLOSS	420
18, 20	3/4	1 5/16-12	1 3/16-12	16	16	38	31	50	280	12-16F5OMLOS	12-16F5OMLOSS	420
18, 20	3/4	1 5/8-12	1 3/16-12	16	16	46	32	51	350	12-20F5OMLOS	12-20F5OMLOSS	420
22, 25	1	1 5/16-12	1 7/16-12	21	21	41	32	50	271	16F5OMLOS	16F5OMLOSS	420
22, 25	1	1 1/16-12	1 7/16-12	21	16	41	36	55	275	16-12F5OMLOS	16-12F5OMLOSS	420
22, 25	1	1 5/8-12	1 7/16-12	21	21	46	34	52	428	16-20F5OMLOS	16-20F5OMLOSS	420
28, 30, 32	1 1/4	1 5/8-12	1 11/16-12	26	26	46	34	52	391	20F5OMLOS	20F5OMLOSS	420
28, 30, 32	1 1/4	1 5/16-12	1 11/16-12	26	21	48	39	58	401	20-16 F5OLO-S	20-16F5OMLOSS	420
28, 30, 32	1 1/4	1 7/8-12	1 11/16-12	26	32	54	36	54	557	20-24 F5OLO-S	20-24F5OMLOSS	350
35, 38	1 1/2	1 7/8-12	2-12	32	32	54	36	54	412	24 F5OLO-S	24F5OMLOSS	350
35, 38	1 1/2	1 5/8-12	2-12	32	26	54	41	60	581	24-20 F5OLO-S	24-20F5OMLOSS	350
50	2	2 1/2-12	2 1/2-12	45	40	70	40	59	900	32 F5OLO-S	32F5OMLOSS	200

O-Lok® is delivered with NBR elastomeric seals as standard. For more details on other seal materials see page J73–J74.

Part numbers shown are part of our current manufacturing programme.

Imperial and metric parts may vary in hexagon dimensions.

$$\frac{\text{PN (bar)}}{10} = \text{PN (MPa)}$$

Pressure ratings – PN shown, apply to Steel and Stainless Steel versions of the product.

FF5OMLO Extended male stud connector

O-Lok® ORFS tube end/Male UN/UNF thread – O-ring (ISO 11926)
SAE 521720 (Previously 520122)

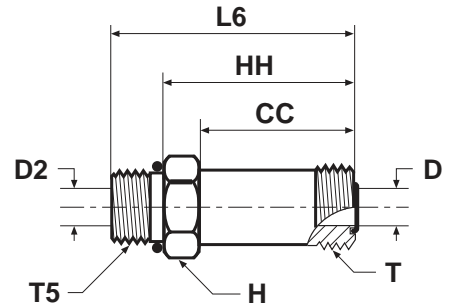

Tube O.D.		Thread UN/UNF-2A T5	Thread UN/UNF-2A T	CC	D	D2	H	HH	L6	Weight (steel)	O-Lok® Steel	O-Lok® Stainless Steel	PN (bar)
mm	in.			mm	mm	mm	mm	mm	mm	g/1 piece			
6	1/4	7/16-20	9/16-18	34	5	5	16	42	53	51	4 FF5OLO-S	4FF5OMLOSS	630
8, 10	5/16, 3/8	9/16-18	11/16-16	37	7	7	19	46	58	79	6 FF5OLO-S	6FF5OMLOSS	630
12	1/2	3/4-16	13/16-16	44	10	10	22	54	68	125	8 FF5OLO-S	8FF5OMLOSS	630
14, 15, 16	5/8	7/8-14	1-14	52	13	13	27	64	80	212	10 FF5OLO-S	10FF5OMLOSS	420
18, 20	3/4	1 1/16-12	1 3/16-12	52	16	16	33	77	96	309	12 FF5OLO-S	12FF5OMLOSS	420
22, 25	1	1 5/16-12	1 7/16-12	72	21	21	41	87	105	435	16 FF5OLO-S	16FF5OMLOSS	420
28, 30, 32	1 1/4	1 5/8-12	1 11/16-12	86	26	26	48	102	121	818	20 FF5OLO-S	20FF5OMLOSS	420
35, 38	1 1/2	1 7/8-12	2-12	97	32	32	54	115	134	1430	24 FF5OLO-S	24FF5OMLOSS	350

O-Lok® is delivered with NBR elastomeric seals as standard. For more details on other seal materials see page J73–J74.

Part numbers shown are part of our current manufacturing programme.

Imperial and metric parts may vary in hexagon dimensions.

$$\frac{\text{PN (bar)}}{10} = \text{PN (MPa)}$$

Pressure ratings – PN shown, apply to Steel and Stainless Steel versions of the product.

WF5OLO Bulkhead male connector

O-Lok® ORFS tube end/Male UN/UNF – O-ring (ISO 11926)

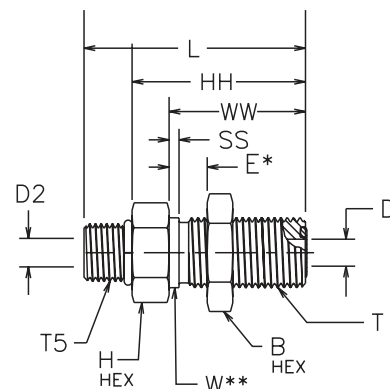

Tube O.D. mm	Tube O.D. in.	Thread UN/UNF-2A T	Thread UN/UNF-2A T5	B mm	D mm	D2 mm	E mm	H mm	HH mm	L mm	SS mm	W mm	WW mm	Weight (steel) g/1 piece	O-Lok® Steel	PN (bar)
6	1/4	9/16-18	7/16-20	21	5	5	14	21	43	54	2	14	32	75	4 WF5OLO-WLNL-S	630
6	1/4	9/16-18	9/16-18	21	5	8	14	21	43	55	2	14	32	88	4-6 WF5OLO-WLNL-S	630
8, 10	5/16, 3/8	11/16-16	9/16-18	25	7	8	14	25	46	58	2	18	34	112	6 WF5OLO-WLNL-S	630
12	1/2	13/16-16	3/4-16	29	10	10	14	29	52	65	2	21	37	147	8 WF5OLO-WLNL-S	630
14, 15, 16	5/8	1-14	7/8-14	33	13	13	13	33	51	67	2	25	41	295	10 WF5OLO-WLNL-S	420
18, 20	3/4	1 3/16-12	1 1/16-12	41	16	16	13	41	52	71	2	30	42	330	12 WF5OLO-WLNL-S	420

O-Lok® is delivered with NBR elastomeric seals as standard. For more details on other seal materials see page J73–J74.

Part numbers shown are part of our current manufacturing programme.

Imperial and metric parts may vary in hexagon dimensions.

For the version without the locknut remove "WLNL" (e.g. 12 WF5OLO)

$$\frac{\text{PN (bar)}}{10} = \text{PN (MPa)}$$

J

F42EDMLO Male stud connector

O-Lok® ORFS tube end /Male BSPP thread – ED seal (ISO 1179)

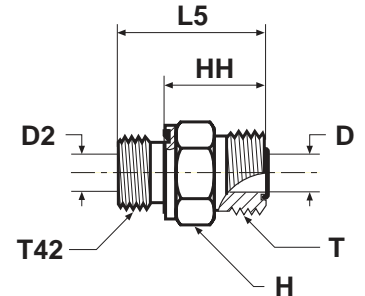

Tube O.D.		BSPP male thread T42	Thread UN/UNF-2A T	D mm	D2 mm	H mm	HH mm	L5 mm	Weight (steel) g/1 piece	O-Lok®		PN (bar)
mm	in.									Steel	Stainless Steel	
6	1/4	1/8	9/16-18	5	4	17	18	26	29	4F42EDMLOS	4F42EDMLOSS	630
6	1/4	1/4	9/16-18	5	5	19	18	31	42	4-4F42EDMLOS	4-4F42EDMLOSS	630
6	1/4	3/8	9/16-18	5	5	22	20	32	61	4-6F42EDMLOS	4-6F42EDMLOSS	630
6	1/4	1/2	9/16-18	5	5	27	21	35	119	4-8F42EDMLOS	4-8F42EDMLOSS	420
8, 10	5/16, 3/8	1/4	11/16-16	7	5	19	20	32	45	6F42EDMLOS	6F42EDMLOSS	630
8, 10	5/16, 3/8	1/8	11/16-16	7	4	19	23	31	44	6-2F42EDMLOS	6-2F42EDMLOSS	630
8, 10	5/16, 3/8	3/8	11/16-16	7	7	22	21	33	63	6-6F42EDMLOS	6-6F42EDMLOSS	630
8, 10	5/16, 3/8	1/2	11/16-16	7	7	27	23	37	122	6-8F42EDMLOS	6-8F42EDMLOSS	420
8, 10	5/16, 3/8	3/4	11/16-16	7	7	32	24	40	192	6-12F42EDMLOS	6-12F42EDMLOSS	420
12	1/2	3/8	13/16-16	10	8	22	23	35	196	8F42EDMLOS	8F42EDMLOSS	630
12	1/2	1/4	13/16-16	10	5	22	25	38	193	8-4F42EDMLOS	8-4F42EDMLOSS	630
12	1/2	1/2	13/16-16	10	10	27	24	38	198	8-8F42EDMLOS	8-8F42EDMLOSS	420
12	1/2	3/4	13/16-16	10	10	32	26	42	205	8-12F42EDMLOS	8-12F42EDMLOSS	420
14, 15, 16	5/8	1/2	1-14	13	13	27	27	41	332	10F42EDMLOS	10F42EDMLOSS	420
14, 15, 16	5/8	3/8	1-14	13	8	27	31	43	315	10-6F42EDMLOS	10-6F42EDMLOSS	420
14, 15, 16	5/8	3/4	1-14	13	13	32	29	45	348	10-12F42EDMLOS	10-12F42EDMLOSS	420
14, 15, 16	5/8	1	1-14	13	13	41	30	48	360	10-16F42EDMLOS	10-16F42EDMLOSS	420
18, 20	3/4	3/4	1 3/16-12	16	16	32	30	46	200	12F42EDMLOS	12F42EDMLOSS	420
18, 20	3/4	1/2	1 3/16-12	16	12	32	34	49	183	12-8F42EDMLOS	12-8F42EDMLOSS	420
18, 20	3/4	1	1 3/16-12	16	16	41	31	49	362	12-16F42EDMLOS	12-16F42EDMLOSS	420
18, 20	3/4	1 1/4	1 3/16-12	16	16	50	33	53	505	12-20F42EDMLOS	12-20F42EDMLOSS	420
22, 25	1	1	1 7/16-12	21	20	41	32	50	343	16F42EDMLOS	16F42EDMLOSS	420
22, 25	1	1/2	1 7/16-12	21	12	41	36	50	380	16-8F42EDMLOS	16-8F42EDMLOSS	420
22, 25	1	3/4	1 7/16-12	21	16	41	36	52	411	16-12F42EDMLOS	16-12F42EDMLOSS	420
22, 25	1	1 1/4	1 7/16-12	21	21	50	34	54	487	16-20F42EDMLOS	16-20F42EDMLOSS	420
22, 25	1	1 1/2	1 7/16-12	21	21	55	36	58	715	16-24F42EDMLOS	16-24F42EDMLOSS	350
28, 30, 32	1 1/4	1 1/4	1 11/16-12	25	25	50	34	54	454	20F42EDMLOS	20F42EDMLOSS	420
28, 30, 32	1 1/4	1	1 11/16-12	26	20	46	39	57	412	20-16F42EDMLOS	20-16F42EDMLOSS	420
28, 30, 32	1 1/4	1 1/2	1 11/16-12	26	26	55	36	58	532	20-24F42EDMLOS	20-24F42EDMLOSS	350
35, 38	1 1/2	1 1/2	2-12	32	32	55	36	58	585	24F42EDMLOS	24F42EDMLOSS	350
35, 38	1 1/2	1 1/4	2-12	32	25	55	41	61	540	24-20F42EDMLOS	24-20F42EDMLOSS	350
50	2	2	2 1/2-12	40	40	75	41	65	900	32F42EDMLOS	32F42EDMLOSS	200

O-Lok® is delivered with NBR elastomeric seals as standard. For more details on other seal materials see page J73-J74.

Part numbers shown are part of our current manufacturing programme.

Imperial and metric parts may vary in hexagon dimensions.

$$\frac{\text{PN (bar)}}{10} = \text{PN (MPa)}$$

Pressure ratings – PN shown, apply to Steel and Stainless Steel versions of the product.

F82EDMLO Male stud connector

O-Lok® ORFS tube end /Male metric thread – ED seal (ISO 9974)

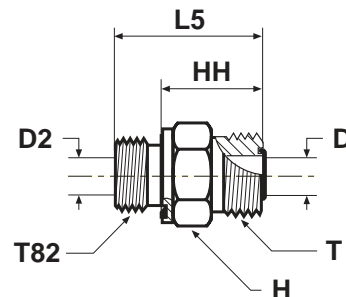

Tube O.D.		Thread metric T87	Thread UN/UNF-2A T	D mm	D2 mm	H mm	HH mm	L5 mm	Weight (steel) g/1 piece	O-Lok® Steel	O-Lok® Stainless Steel	PN (bar)
mm	in.											
6	1/4	M10 1.0	9/16-18	5	4	17	18	26	20	4M10F82EDMLOS	4M10F82EDMLOSS	630
6	1/4	M12 1.5	9/16-18	5	4	17	18	30	24	4M12F82EDMLOS	4M12F82EDMLOSS	630
6	1/4	M14 1.5	9/16-18	5	5	19	19	31	29	4M14F82EDMLOS	4M14F82EDMLOSS	630
6	1/4	M16 1.5	9/16-18	5	7	22	19	31	33	4M16F82EDMLOS	4M16F82EDMLOSS	630
8, 10	5/16, 3/8	M12 1.5	11/16-16	7	4	19	23	35	35	6M12F82EDMLOS	6M12F82EDMLOSS	630
8, 10	5/16, 3/8	M14 1.5	11/16-16	7	5	19	20	32	40	6M14F82EDMLOS	6M14F82EDMLOSS	630
8, 10	5/16, 3/8	M16 1.5	11/16-16	7	7	22	20	32	43	6M16F82EDMLOS	6M16F82EDMLOSS	630
12	1/2	M16 1.5	13/16-16	10	7	22	26	38	49	8M16F82EDMLOS	8M16F82EDMLOSS	630
12	1/2	M18 1.5	13/16-16	10	8	24	23	35	55	8M18F82EDMLOS	8M18F82EDMLOSS	630
14, 15, 16	5/8	M16 1.5	1-14	13	7	27	30	42	70	10M16F82EDMLOS	10M16F82EDMLOSS	420
14, 15, 16	5/8	M18 1.5	1-14	13	8	27	31	43	85	10M18F82EDMLOS	10M18F82EDMLOSS	420
14, 15, 16	5/8	M22 1.5	1-14	13	12	27	27	41	127	10M22F82EDMLOS	10M22F82EDMLOSS	420
18, 20	3/4	M27 2	1 3/16-12	16	16	32	30	46	187	12M27F82EDMLOS	12M27F82EDMLOSS	420
22, 25	1	M33 2	1 7/16-12	20	20	41	32	50	270	16M33F82EDMLOS	16M33F82EDMLOSS	420
28, 30, 32	1 1/4	M42 2	1 11/16-12	26	25	50	34	54	390	20M42F82EDMLOS	20M42F82EDMLOSS	420
35, 38	1 1/2	M48 2	2-12	32	32	55	36	58	412	24M48F82EDMLOS	24M48F82EDMLOSS	350

O-Lok® is delivered with NBR elastomeric seals as standard. For more details on other seal materials see page J73–J74.

Part numbers shown are part of our current manufacturing programme.

Imperial and metric parts may vary in hexagon dimensions.

$$\frac{\text{PN (bar)}}{10} = \text{PN (MPa)}$$

Pressure ratings – PN shown, apply to Steel and Stainless Steel versions of the product.

FLO Male stud connector

O-Lok® ORFS tube end/Male NPTF* thread (SAE J476)

*Stainless Steel = NPT to prevent galling

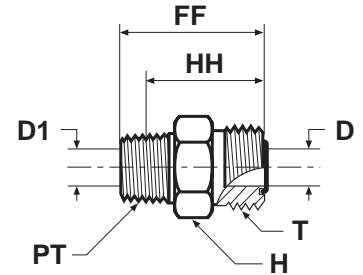

Tube O.D.		Thread NPTF PT	Thread UN/UNF-2A T	D mm	D1 mm	FF mm	H mm	HH mm	Weight (steel) g/1 piece	O-Lok® Steel	O-Lok® Stainless Steel	PN (bar)
mm	in.											
6	1/4	1/8-27	9/16-18	5	5	27	16	21	26	4 FLO-S	4 FLO-SS	420
6	1/4	1/4-18	9/16-18	5	7	32	16	23	34	4-4 FLO-S	4-4 FLO-SS	420
6	1/4	3/8-18	9/16-18	5	5	36	19	25	47	4-6 FLO-S	4-6 FLO-SS	420
8, 10	5/16, 3/8	1/4-16	11/16-16	7	7	32	19	23	39	6 FLO-S	6 FLO-SS	420
8, 10	5/16, 3/8	3/8-18	11/16-16	7	10	34	19	25	52	6-6 FLO-S	6-6 FLO-SS	420
8, 10	5/16, 3/8	1/2-14	11/16-16	7	13	39	22	28	82	6-8 FLO-S	6-8 FLO-SS	420
12	1/2	3/8-18	13/16-16	10	10	38	22	29	83	8 FLO-S	8 FLO-SS	420
12	1/2	1/2-14	13/16-16	10	13	42	22	30	84	8-8 FLO-S	8-8 FLO-SS	420
12	1/2	3/4-14	13/16-16	10	18	43	29	31	166	8-12 FLO-S	8-12 FLO-SS	380
14, 15, 16	5/8	1/2-14	1-14	13	13	46	27	35	115	10 FLO-S	10 FLO-SS	420
14, 15, 16	5/8	3/4-14	1-14	13	18	46	29	34	138	10-12 FLO-S	10-12 FLO-SS	380
18, 20	3/4	3/4-14	1 3/16-12	15	18	49	32	37	179	12 FLO-S	12 FLO-SS	380
18, 20	3/4	1/2-14	1 3/16-12	15	13	49	32	37	165	12-8 FLO-S	12-8 FLO-SS	420
18, 20	3/4	1-11 1/2	1 3/16-12	15	24	54	35	40	225	12-16 FLO-S	12-16 FLO-SS	310
22, 25	1	1-11 1/2	1 7/16-12	21	24	56	38	41	271	16 FLO-S	16 FLO-SS	310
22, 25	1	3/4-14	1 7/16-12	21	18	51	38	39	238	16-12 FLO-S	16-12 FLO-SS	380
28, 30, 32	1 1/4	1 1/4-11 1/2	1 11/16-12	26	32	58	48	43.5	424	20 FLO-S	20 FLO-SS	210
35, 38	1 1/2	1 1/2-11 1/2	2-12	32	38	61	54	46.0	534	24 FLO-S	24 FLO-SS	200

O-Lok® is delivered with NBR elastomeric seals as standard. For more details on other seal materials see page J73-J74.

Part numbers shown are part of our current manufacturing programme.

Imperial and metric parts may vary in hexagon dimensions.

$$\frac{\text{PN (bar)}}{10} = \text{PN (MPa)}$$

Pressure ratings – PN shown, apply to Steel and Stainless Steel versions of the product.

F687OML Swivel male stud

O-Lok® ORFS Female swivel end/Male metric thread – O-ring (ISO 6149-2)

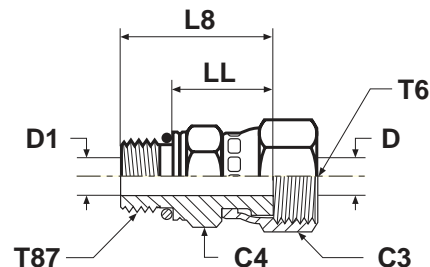

Tube O.D.		Thread metric T87	Thread UN/UNF-2B T6	C3 mm	C4 mm	D mm	D1 mm	L8 mm	LL mm	Weight (steel) g/1 piece	O-Lok® Steel	O-Lok® Stainless Steel	PN (bar)
mm	in.												
6	1/4	M12 1.5	9/16-18	17	17	4	4	38	27	53	4M12F687OMLS	4M12F687OMLSS	500
6	5/16	M12 1.5	11/16-16	22	17	7	4	40	29	66	6M12F687OMLS	6M12F687OMLSS	630
8	3/8	M14 1.5	11/16-16	22	19	7	6	40	29	72	6M14F687OMLS	6M14F687OMLSS	630
8, 10	5/16, 3/8	M16 1.5	11/16-16	22	22	7	7	42	29	85	6M16F687OMLS	6M16F687OMLSS	630
12	1/2	M16 1.5	13/16-16	24	22	9	7	49	36	110	8M16F687OMLS	8M16F687OMLSS	630
14, 15, 16	5/8	M22 1.5	1-14	30	27	12	12	53	38	173	10M22F687OMLS	10M22F687OMLSS	420
18, 20	3/4	M22 1.5	1 3/16-12	36	30	14	12	57	42	230	12M22F687OMLS	12M22F687OMLSS	420
18, 20	3/4	M27 2	1 3/16-12	36	32	14	14	61	42	275	12M27F687OMLS	12M27F687OMLSS	420
22, 25	1	M27 2	1 7/16-12	41	36	20	15	68	49	420	16M27F687OMLS	16M27F687OMLSS	420
22, 25	1	M33 2	1 7/16-12	41	41	20	20	68	49	462	16M33F687OMLS	16M33F687OMLSS	420
28, 30, 32	1 1/4	M42 2	1 11/16-12	50	50	26	26	68	49	622	20M42F687OMLS	20M42F687OMLSS	350
35, 38	1 1/2	M48 2	2-12	60	55	32	32	71	50	885	24M48F687OMLS	24M48F687OMLSS	280

O-Lok® is delivered with NBR elastomeric seals as standard. For more details on other seal materials see page J73–J74.

Part numbers shown are part of our current manufacturing programme.

Imperial and metric parts may vary in hexagon dimensions.

$$\frac{\text{PN (bar)}}{10} = \text{PN (MPa)}$$

Pressure ratings – PN shown, apply to Steel and Stainless Steel versions of the product.



F65OL Swivel male stud

O-Lok® ORFS female swivel end/Male UN/UNF thread – O-ring (ISO 11926)
SAE 520181

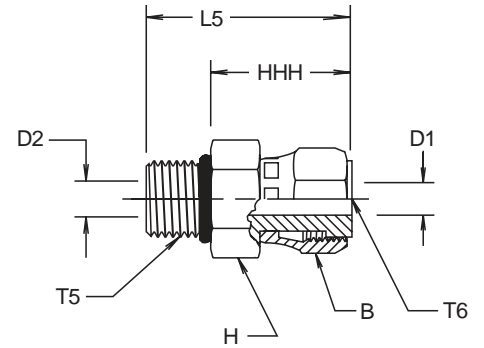

Tube O.D. mm	Tube O.D. in.	Thread UN/UNF-2A T5	Thread UN/UNF-2B T6	B mm	D1 mm	D2 mm	H mm	HHH mm	L5 mm	Weight (steel) g/1 piece	O-Lok® Steel	PN (bar)
6	1/4	7/16-20	9/16-18	18	4	5	17	26	37	53	4 F65OL-S	500
8, 10	5/16, 3/8	9/16-18	11/16-16	21	7	7	19	28	40	66	6 F65OL-S	630
12	1/2	3/4-16	13/16-16	24	9	10	22	35	50	110	8 F65OL-S	630
14, 15, 16	5/8	7/8-14	1-14	29	12	13	27	38	54	173	10 F65OL-S	420
18, 20	3/4	1 1/16-12	1 3/16-12	35	14	16	32	41	59	275	12 F65OL-S	420
22, 25	1	1 5/16-12	1 7/16-12	42	20	21	41	49	68	462	16 F65OL-S	420
28, 30, 32	1 1/4	1 5/8-12	1 11/16-12	48	26	26	46	50	68	622	20 F65OL-S	350

O-Lok® is delivered with NBR elastomeric seals as standard. For more details on other seal materials see page J73–J74.

Part numbers shown are part of our current manufacturing programme.

Imperial and metric parts may vary in hexagon dimensions.

$$\frac{\text{PN (bar)}}{10} = \text{PN (MPa)}$$

F642EDMLO Swivel male stud

O-Lok® ORFS Swivel female end/Male BSPP thread – ED seal (ISO 1179)

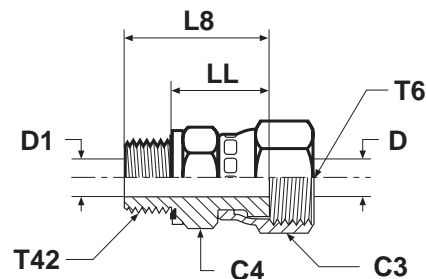

Tube O.D.		Thread BSPP T42	Thread UN/UNF-2B T6	C3 mm	C4 mm	D mm	D1 mm	L8 mm	LL mm	Weight (steel) g/1 piece	O-Lok® Steel	O-Lok® Stainless Steel	PN (bar)
mm	in.												
6	1/4	1/8	9/16-18	17	14	4	4	34	26	43	4F642EDMLS	4F642EDMLSS	500
6	1/4	1/4	9/16-18	17	19	4	4	38	26	59	4-4F642EDMLS	4-4F642EDMLSS	500
8, 10	5/16, 3/8	1/4	11/16-16	22	19	7	5	40	28	72	6F642EDMLS	6F642EDMLSS	630
8, 10	5/16, 3/8	3/8	11/16-16	22	22	7	7	40	28	86	6-6F642EDMLS	6-6F642EDMLSS	630
8, 10	5/16, 3/8	1/2	11/16-16	22	27	7	7	42	28	92	6-8F642EDMLS	6-8F642EDMLSS	420
12	1/2	3/8	13/16-16	24	22	9	8	47	35	104	8F642EDMLS	8F642EDMLSS	630
12	1/2	1/4	13/16-16	24	22	9	5	47	35	98	8-4F642EDMLS	8-4F642EDMLSS	630
12	1/2	1/2	13/16-16	24	27	9	9	49	35	142	8-8F642EDMLS	8-8F642EDMLSS	420
14, 15, 16	5/8	1/2	1-14	30	27	12	12	52	38	165	10F642EDMLS	10F642EDMLSS	420
14, 15, 16	5/8	3/4	1-14	30	32	12	12	54	38	185	10-12F642EDMLS	10-12F642EDMLSS	420
18, 20	3/4	3/4	1 3/16-12	36	32	14	14	57	41	266	12F642EDMLS	12F642EDMLSS	420
18, 20	3/4	1/2	1 3/16-12	36	30	14	12	55	41	220	12-8F642EDMLS	12-8F642EDMLSS	420
22, 25	1	1	1 7/16-12	41	41	20	20	67	49	414	16F642EDMLS	16F642EDMLSS	420
28, 30, 32	1 1/4	1 1/4	1 11/16-12	50	50	26	25	69	49	623	20F642EDMLS	20F642EDMLSS	350
35, 38	1 1/2	1 1/2	2-12	60	55	32	32	72	50	885	24F642EDMLS	24F642EDMLSS	280

O-Lok® is delivered with NBR elastomeric seals as standard. For more details on other seal materials see page J73–J74.

Part numbers shown are part of our current manufacturing programme.

Imperial and metric parts may vary in hexagon dimensions.

$$\frac{\text{PN (bar)}}{10} = \text{PN (MPa)}$$

Pressure ratings – PN shown, apply to Steel and Stainless Steel versions of the product.



F682EDMLO Swivel male stud

O-Lok® ORFS Swivel female end/Male metric thread – ED seal (ISO 9974)

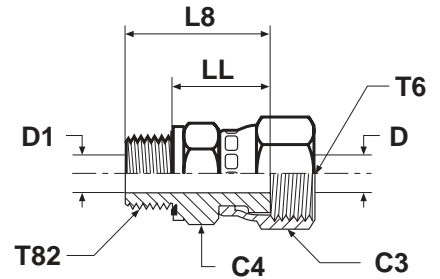

Tube O.D.		Thread metric T82	Thread UN/UNF-2B T6	C3 mm	C4 mm	D mm	D1 mm	L8 mm	LL mm	Weight (steel) g/1 piece	O-Lok® Steel	O-Lok® Stainless Steel	PN (bar)
mm	in.												
6	1/4	M12 1.5	9/16-18	17	17	4	4	39	27	56	4M12F682EDMLS	4M12F682EDMLSS	500
8, 10	5/16, 3/8	M14 1.5	11/16-16	22	19	7	5	41	29	73	6M14F682EDMLS	6M14F682EDMLSS	630
8, 10	5/16, 3/8	M16 1.5	11/16-16	24	22	7	7	41	29	85	6M16F682EDMLS	6M16F682EDMLSS	630
12	1/2	M16 1.5	13/16-16	24	22	9	7	48	36	109	8M16F682EDMLS	8M16F682EDMLSS	630
14, 15, 16	5/8	M22 1.5	1-14	30	27	12	12	53	39	165	10M22F682EDMLS	10M22F682EDMLSS	420
18, 20	3/4	M27 2	1 3/16-12	36	32	14	14	58	42	282	12M27F682EDMLS	12M27F682EDMLSS	420
22, 25	1	M33 2	1 7/16-12	41	41	20	20	68	50	467	16M33F682EDMLS	16M33F682EDMLSS	420
28, 30, 32	1 1/4	M42 2	1 11/16-12	50	50	26	25	70	50	635	20M42F682EDMLS	20M42F682EDMLSS	350
35, 38	1 1/2	M48 2	2-12	60	55	32	32	72	50	885	24M48F682EDMLS	24M48F682EDMLSS	280

O-Lok® is delivered with NBR elastomeric seals as standard. For more details on other seal materials see page J73–J74.

Part numbers shown are part of our current manufacturing programme.

Imperial and metric parts may vary in hexagon dimensions.

$$\frac{\text{PN (bar)}}{10} = \text{PN (MPa)}$$

Pressure ratings – PN shown, apply to Steel and Stainless Steel versions of the product.

C87OMLO Male stud elbow

O-Lok® ORFS tube end/Male metric thread – O-ring (ISO 6149-2)
SAE 52M0287 ISO 8434-3 SDE

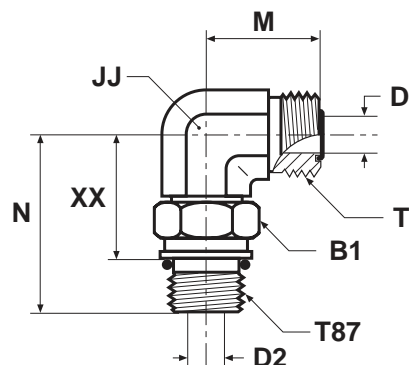

Tube O.D.		Thread metric T87	Thread UN/UNF-2B T	B1 mm	D mm	D2 mm	JJ mm	M mm	N mm	XX mm	Weight (steel) g/1 piece	O-Lok® Steel	O-Lok® Stainless Steel	PN (bar)
mm	in.													
6	1/4	M10 1.0	9/16-18	14	5	3	14	22	31	21	50	4M10C87OMLOS	4M10C87OMLOSS	420
6	1/4	M12 1.5	9/16-18	17	5	4	14	22	33	22	52	4M12C87OMLOS	4M12C87OMLOSS	420
6	1/4	M14 1.5	9/16-18	19	5	6	14	24	36	25	55	4M14C87OMLOS	4M14C87OMLOSS	420
8, 10	5/16, 3/8	M12 1.5	11/16-18	17	7	4	19	25	36	25	60	6M12C87OMLOS	6M12C87OMLOSS	420
8, 10	5/16, 3/8	M14 1.5	11/16-18	19	7	6	19	25	36	25	60	6M14C87OMLOS	6M14C87OMLOSS	420
8, 10	5/16, 3/8	M16 1.5	11/16-16	22	7	7	19	25	38	27	65	6M16C87OMLOS	6M16C87OMLOSS	420
12	1/2	M14 1.5	13/16-16	19	10	6	19	28	36	25	150	8M14C87OMLOS	8M14C87OMLOSS	420
12	1/2	M16 1.5	13/16-16	22	10	7	19	28	38	27	92	8M16C87OMLOS	8M16C87OMLOSS	420
12	1/2	M18 1.5	13/16-16	24	10	9	19	28	41	27	161	8M18C87OMLOS	8M18C87OMLOSS	420
12	1/2	M22 1.5	13/16-16	27	10	12	27	31	49	27	200	8M22C87OMLOS	8M22C87OMLOSS	420
14, 15, 16	5/8	M18 1.5	1-14	24	13	9	27	33	48	27	190	10M18C87OMLOS	10M18C87OMLOSS	420
14, 15, 16	5/8	M22 1.5	1-14	27	13	12	27	33	49	34	214	10M22C87OMLOS	10M22C87OMLOSS	420
18, 20	3/4	M22 1.5	1 3/16-12	27	16	12	30	37	50	35	390	12M22C87OMLOS	12M22C87OMLOSS	420
18, 20	3/4	M27 2	1 3/16-12	32	16	15	30	37	56	37	440	12M27C87OMLOS	12M27C87OMLOSS	420
22, 25	1	M33 2	1 7/16-12	41	21	20	36	42	59	41	501	16M33C87OMLOS	16M33C87OMLOSS	420
28, 30, 32	1 1/4	M33 2	1 11/16-12	41	26	20	41	45	62	42	530	20M33C87OMLOS	20M33C87OMLOSS	350
28, 30, 32	1 1/4	M42 2	1 11/16-12	50	26	26	41	45	63	44	561	20M42C87OMLOS	20M42C87OMLOSS	280
35, 38	1 1/2	M48 2	2-12	55	32	32	50	49	72	47	684	24M48C87OMLOS	24M48C87OMLOSS	280

O-Lok® is delivered with NBR elastomeric seals as standard. For more details on other seal materials see page J73–J74.

Part numbers shown are part of our current manufacturing programme.

Imperial and metric parts may vary in hexagon dimensions.

$$\frac{PN \text{ (bar)}}{10} = PN \text{ (MPa)}$$

Pressure ratings – PN shown, apply to Steel and Stainless Steel versions of the product.

CC87OMLO Extended male stud elbow

O-Lok® ORFS tube end/Male metric thread – O-ring (ISO 6149-2)
 SAE 52M1587 ISO 8434-3 SDEL

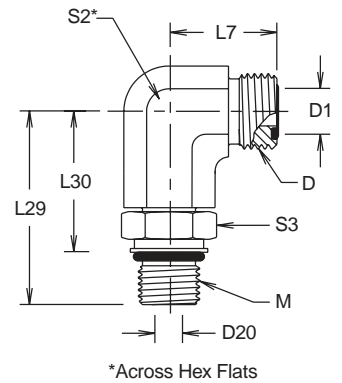

mm	Tube O.D.		Thread metric M	Thread UN/UNF-2A D	D1 mm	D20 mm	L7 mm	L29 mm	L30 mm	S2 mm	S3 mm	Weight (steel) g/1 piece	O-Lok® Steel	PN (bar)
	mm	in.												
6	1/4		M12 1.5	9/16-18	5	4	21	56	24	14	17	44	4M12CC87OMLOS	420
8, 10	5/16, 3/8		M14 1.5	11/16-16	7	6	25	56	21	17	19	51	6M14CC87OMLOS	420
8, 10	5/16, 3/8		M16 1.5	11/16-16	7	7	25	67	30	17	22	51	6M16CC87OMLOS	420
12	1/2		M18 1.5	13/16-16	10	9	28	75	34	19	24	150	8M18CC87OMLOS	420
12	1/2		M22 1.5	13/16-16	10	12	31	88	39	27	27	150	8M22CC87OMLOS	420
14, 15, 16	5/8		M22 1.5	1-14	13	12	34	88	39	27	27	160	10M22CC87OMLOS	420
18, 20	3/4		M27 2	1 3/16-12	16	15	38	101	45	27	32	290	12M27CC87OMLOS	420
22, 25	1		M33 2	1 7/16-12	21	20	42	115	55	36	41	480	16M33CC87OMLOS	420
28, 30, 32	1 1/4		M42 2	1 11/16-12	26	26	45	127	64	41	50	630	20M42CC87OMLOS	280

O-Lok® is delivered with NBR elastomeric seals as standard. For more details on other seal materials see page J73–J74.

Part numbers shown are part of our current manufacturing programme.

Imperial and metric parts may vary in hexagon dimensions.

$$\frac{\text{PN (bar)}}{10} = \text{PN (MPa)}$$

C50MLO Male stud elbow

O-Lok® ORFS tube end/Male UN/UNF thread – O-ring (ISO 11926)
SAE 520220

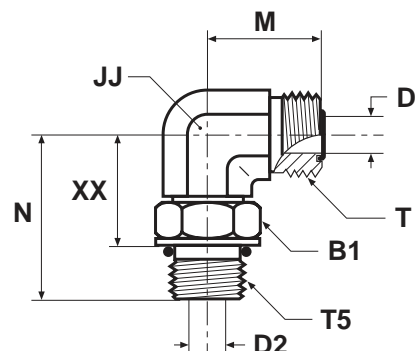

Tube O.D.		Thread UN/UNF-2A T5	Thread UN/UNF-2A T	B1	D	D2	JJ	M	N	XX	Weight (steel)	O-Lok® Steel	O-Lok® Stainless Steel	PN (bar)
mm	in.			mm	mm	mm	mm	mm	mm	mm	g/1 piece			
6	1/4	7/16-20	9/16-18	16	5	5	14	22	33	22	53	4C50MLOS	4C50MLOSS	420
6	1/4	9/16-18	9/16-18	19	5	8	19	24	37	25	66	4-6C50MLOS	4-6C50MLOSS	420
6	1/4	3/4-16	9/16-18	24	5	10	19	25	41	27	67	4-8 C50LO-S	4-8C50MLOSS	420
8, 10	5/16, 3/8	9/16-18	11/16-16	19	7	8	19	25	37	25	68	6C50MLOS	6C50MLOSS	420
8, 10	5/16, 3/8	7/16-20	11/16-16	16	7	5	19	25	35	24	57	6-4 C50LO-S	6-4C50MLOSS	420
8, 10	5/16, 3/8	3/4-16	11/16-16	24	7	10	19	27	41	27	105	6-8C50MLOS	6-8C50MLOSS	420
8, 10	5/16, 3/8	7/8-14	11/16-16	27	7	12	22	29	50	34	196	6-10 C50LO-S	6-10C50MLOSS	420
8, 10	5/16, 3/8	1 1/16-12	11/16-16	36	7	16	27	33	55	37	250	6-12 C50LO-S	6-12C50MLOSS	420
12	1/2	3/4-16	13/16-16	24	10	10	19	28	41	27	164	8C50MLOS	8C50MLOSS	420
12	1/2	9/16-18	13/16-16	19	10	7	19	28	37	25	81	8-6 C50LO-S	8-6C50MLOSS	420
12	1/2	7/8-14	13/16-16	27	10	13	27	31	50	34	187	8-10C50MLOS	8-10C50MLOSS	420
12	1/2	1 1/16-12	13/16-16	36	10	15	30	36	55	37	201	8-12 C50LO-S	8-12C50MLOSS	420
14, 15, 16	5/8	7/8-14	1-14	27	13	13	27	33	50	34	214	10C50MLOS	10C50MLOSS	420
14, 15, 16	5/8	3/4-16	1-14	24	13	10	27	33	46	32	175	10-8 C50LO-S	10-8C50MLOSS	420
14, 15, 16	5/8	1 1/16-12	1-14	35	13	16	30	36	55	37	248	10-12 C50LO-S	10-12C50MLOSS	420
18, 20	3/4	1 1/16-12	1 3/16-12	36	16	16	30	37	55	37	442	12C50MLOS	12C50MLOSS	420
18, 20	3/4	3/4-16	1 3/16-12	24	16	10	30	37	47	33	325	12-8C50MLOS	12-8C50MLOSS	420
18, 20	3/4	7/8-14	1 3/16-12	27	16	13	30	37	51	35	296	12-10C50MLOS	12-10C50MLOSS	420
18, 20	3/4	1 5/16-12	1 3/16-12	41	16	22	36	41	60	41	346	12-16C50MLOS	12-16C50MLOSS	380
22, 25	1	1 5/16-12	1 7/16-12	41	21	21	37	42	60	41	502	16 C50LO-S	16C50MLOSS	380
22, 25	1	1 1/16-12	1 7/16-12	35	21	16	37	42	59	40	473	16-12 C50LO-S	16-12C50MLOSS	420
22, 25	1	1 5/8-12	1 7/16-12	48	21	26	41	45	62	44	580	16-20 C50LO-S	16-20C50MLOSS	280
28, 30, 32	1 1/4	1 5/8-12	1 11/16-12	48	26	26	41	45	62	44	563	20 C50LO-S	20C50MLOSS	280
28, 30, 32	1 1/4	1 5/16-12	1 11/16-12	41	26	22	41	45	62	43	563	20-16C50MLOS	20-16C50MLOSS	380
28, 30, 32	1 1/4	1 7/8-12	1 11/16-12	54	26	32	48	49	66	47	764	20-24 C50LO-S	20-24C50MLOSS	280
35, 38	1 1/2	1 7/8-12	2-12	54	32	32	48	49	66	47	689	24 C50LO-S	24C50MLOSS	280
35, 38	1 1/2	1 5/8-12	2-12	48	32	26	48	49	66	47	644	24-20 C50LO-S	24-20C50MLOSS	280
50	2	2 1/2-12	2 1/2-12	70	45	40	64	70	78	59	2200	32 C50LO-S	32C50MLOSS	170

O-Lok® is delivered with NBR elastomeric seals as standard. For more details on other seal materials see page J73–J74.

Part numbers shown are part of our current manufacturing programme.

Imperial and metric parts may vary in hexagon dimensions.

$$\frac{\text{PN (bar)}}{10} = \text{PN (MPa)}$$

Pressure ratings – PN shown, apply to Steel and Stainless Steel versions of the product.

CC5OLO Extended male stud elbow

O-Lok® ORFS tube end/Male UN/UNF thread – O-ring (ISO 11926)
SAE 521520

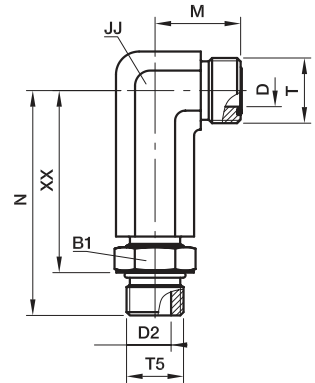

Tube O.D. mm	Tube O.D. in.	Thread UN/UNF-2A T5	Thread UN/UNF-2A T	B1 mm	D mm	D2 mm	JJ mm	M mm	N mm	XX mm	Weight (steel) g/1 piece	O-Lok® Steel	PN (bar)
6	1/4	7/16-20	9/16-18	16	5	5	14	22	57	46	44	4 CC5OLO-S	420
8, 10	5/16, 3/8	9/16-18	11/16-16	19	7	7	19	25	66	54	51	6 CC5OLO-S	420
12	1/2	3/4-16	13/16-16	24	10	10	19	28	75	61	146	8 CC5OLO-S	420
14, 15, 16	5/8	7/8-14	1-14	27	13	13	27	33	90	73	159	10 CC5OLO-S	420
18, 20	3/4	1 1/16-12	1 3/16-12	36	16	16	30	37	101	82	291	12 CC5OLO-S	420
22, 25	1	1 5/16-12	1 7/16-12	41	21	21	36	42	115	96	481	16 CC5OLO-S	380

O-Lok® is delivered with NBR elastomeric seals as standard. For more details on other seal materials see page J73–J74.

Part numbers shown are part of our current manufacturing programme.

Imperial and metric parts may vary in hexagon dimensions.

$$\frac{\text{PN (bar)}}{10} = \text{PN (MPa)}$$

C4OMLO Male stud elbow

O-Lok® ORFS tube end/Male BSPP thread O-ring + retaining ring (ISO 1179)

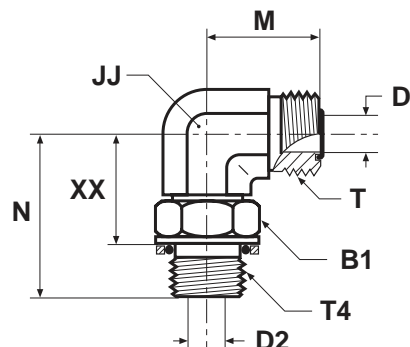

Tube O.D.		Thread BSPP T4	Thread UN/UNF-2A T	B1 mm	D mm	D2 mm	JJ mm	M mm	N mm	XX mm	Weight (steel) g/1 piece	O-Lok® Steel	O-Lok® Stainless Steel	PN (bar)
mm	in.													
6	1/4	1/8	9/16-18	14	5	4	14	22	30	22	49	4C4OMLOS	4C4OMLOSS	250
6	1/4	1/4	9/16-18	19	5	8	19	24	26	25	93	4-4C4OMLOS	4-4C4OMLOSS	250
6	1/4	3/8	9/16-18	22	5	10	19	25	38	27	99	4-6C4OMLOS	4-6C4OMLOSS	250
8, 10	5/16, 3/8	1/4	11/16-16	19	7	8	19	25	36	25	97	6C4OMLOS	6C4OMLOSS	250
8, 10	5/16, 3/8	1/8	11/16-16	14	7	5	19	25	32	20	62	6-2C4OMLOS	6-2C4OMLOSS	250
8, 10	5/16, 3/8	3/8	11/16-16	22	7	10	19	27	38	27	106	6-6C4OMLOS	6-6C4OMLOSS	250
8, 10	5/16, 3/8	1/2	11/16-16	27	7	13	27	29	49	34	120	6-8C4OMLOS	6-8C4OMLOSS	250
12	1/2	3/8	13/16-16	22	10	10	19	28	38	27	108	8C4OMLOS	8C4OMLOSS	250
12	1/2	1/4	13/16-16	19	10	8	19	28	36	25	99	8-4C4OMLOS	8-4C4OMLOSS	250
12	1/2	1/2	13/16-16	27	10	12	27	31	49	34	239	8-8C4OMLOS	8-8C4OMLOSS	250
12	1/2	3/4	13/16-16	36	10	16	30	34	52	37	258	8-12C4OMLOS	8-12C4OMLOSS	250
14, 15, 16	5/8	1/2	1-14	27	13	12	27	33	49	34	274	10C4OMLOS	10C4OMLOSS	250
14, 15, 16	5/8	3/8	1-14	22	13	10	27	33	43	30	235	10-6C4OMLOS	10-6C4OMLOSS	250
14, 15, 16	5/8	3/4	1-14	36	13	16	30	36	52	37	352	10-12C4OMLOS	10-12C4OMLOSS	250
14, 15, 16	5/8	1	1-14	41	13	22	36	40	58	41	382	10-16C4OMLOS	10-16C4OMLOSS	250
18, 20	3/4	3/4	1 3/16-12	36	16	16	30	37	52	37	355	12C4OMLOS	12C4OMLOSS	250
18, 20	3/4	1/2	1 3/16-12	27	16	12	30	37	50	35	297	12-8C4OMLOS	12-8C4OMLOSS	250
18, 20	3/4	1	1 3/16-12	41	16	22	36	41	58	41	362	12-16C4OMLOS	12-16C4OMLOSS	250
22, 25	1	1	1 7/16-12	41	21	22	36	42	58	41	551	16C4OMLOS	16C4OMLOSS	250
22, 25	1	3/4	1 7/16-12	36	21	16	36	42	55	41	533	16-12C4OMLOS	16-12C4OMLOSS	250
22, 25	1	1 1/4	1 7/16-12	50	21	28	41	45	61	44	758	16-20C4OMLOS	16-20C4OMLOSS	210
28, 30, 32	1 1/4	1 1/4	1 11/16-12	50	26	28	41	45	61	44	752	20C4OMLOS	20C4OMLOSS	210
28, 30, 32	1 1/4	1	1 11/16-12	41	26	22	41	45	61	44	712	20-16C4OMLOS	20-16C4OMLOSS	250
28, 30, 32	1 1/4	1 1/2	1 11/16-12	55	26	33	50	49	65	47	821	20-24C4OMLOS	20-24C4OMLOSS	140
35, 38	1 1/2	1 1/2	2-12	55	32	33	50	49	65	47	953	24C4OMLOS	24C4OMLOSS	140

O-Lok® is delivered with NBR elastomeric seals as standard. For more details on other seal materials see page J73-J74.

Part numbers shown are part of our current manufacturing programme.

Imperial and metric parts may vary in hexagon dimensions.

$$\frac{\text{PN (bar)}}{10} = \text{PN (MPa)}$$

Pressure ratings – PN shown, apply to Steel and Stainless Steel versions of the product.

C8OMLO Male stud elbow

O-Lok® ORFS tube end/Male metric thread – O-ring + retaining ring

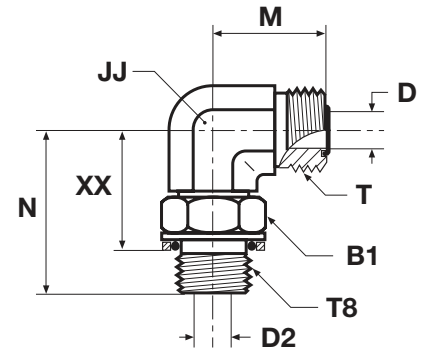

Tube O.D. mm	Tube O.D. in.	Thread metric T8	Thread UN/UNF-2A T	B1 mm	D mm	D2 mm	JJ mm	M mm	N mm	XX mm	Weight (steel) g/1 piece	O-Lok® Steel	PN (bar)
6	1/4	M12 1.5	9/16-18	17	5	4	14	22	33	23	52	4M12C8OMLOS	250
6	1/4	M14 1.5	9/16-18	17	5	6	14	24	36	24	58	4M14C8OMLOS	250
8, 10	5/16, 3/8	M14 1.5	11/16-16	17	7	6	19	25	36	24	62	6M14C8OMLOS	250
8, 10	5/16, 3/8	M16 1.5	11/16-16	19	7	7	19	25	38	26	65	6M16C8OMLOS	250
12	1/2	M16 1.5	13/16-16	19	10	7	19	28	38	26	82	8M16C8OMLOS	250
12	1/2	M18 1.5	13/16-16	22	10	9	19	28	41	29	161	8M18C8OMLOS	250
14, 15, 16	5/8	M18 1.5	1-14	22	13	9	27	33	48	33	185	10M18C8OMLOS	250
14, 15, 16	5/8	M22 1.5	1-14	27	13	12	27	33	49	35	214	10M22C8OMLOS	250
18, 20	3/4	M27 2	1 3/16-12	32	16	15	30	37	56	39	440	12M27C8OMLOS	250
22, 25	1	M33 2	1 7/16-12	38	21	20	36	42	59	43	501	16M33C8OMLOS	140
28, 30, 32	1 1/4	M42 2	1 11/16-12	50	26	26	41	45	63	46	561	20M42C8OMLOS	140
35, 38	1 1/2	M48 2	2-12	55	32	32	50	49	72	49	684	24M48C8OMLOS	140

O-Lok® is delivered with NBR elastomeric seals as standard. For more details on other seal materials see page J73–J74.

Part numbers shown are part of our current manufacturing programme.

Imperial and metric parts may vary in hexagon dimensions.

$$\frac{\text{PN (bar)}}{10} = \text{PN (MPa)}$$

CLO Male stud elbow

O-Lok® ORFS tube end/Male NPTF* thread (SAE J476)

*Stainless Steel = NPT to prevent galling

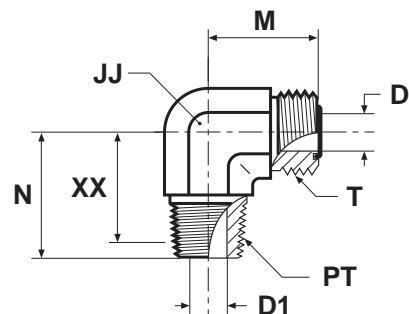

Tube O.D.		Thread NPTF PT	Thread UN/UNF-2A T	D mm	D1 mm	JJ mm	M mm	N mm	XX mm	Weight (steel) g/1 piece	O-Lok® Steel	O-Lok® Stainless Steel	PN (bar)
mm	in.												
6	1/4	1/8-27	9/16-18	5	5	14	22	20	15	39	4 CLO-S	4 CLO-SS	420
6	1/4	1/4-18	9/16-18	5	7	14	22	29	20	50	4-4 CLO-S	4-4 CLO-SS	420
8, 10	5/16, 3/8	1/4-16	11/16-16	7	7	19	25	28	19	75	6 CLO-S	6 CLO-SS	420
8, 10	5/16, 3/8	3/8-18	11/16-16	7	10	19	25	31	22	81	6-6 CLO-S	6-6 CLO-SS	420
8, 10	5/16, 3/8	1/2-14	11/16-16	7	13	22	29	37	26	84	6-8 CLO-S	6-8 CLO-SS	420
12	1/2	3/8-18	13/16-16	10	10	19	28	31	22	89	8 CLO-S	8 CLO-SS	420
12	1/2	1/2-14	13/16-16	10	13	22	28	37	26	125	8-8 CLO-S	8-8 CLO-SS	420
12	1/2	3/4-14	13/16-16	10	18	27	34	40	28	168	8-12 CLO-S	8-12 CLO-SS	280
14, 15, 16	5/8	1/2-14	1-14	13	13	27	33	37	26	154	10 CLO-S	10 CLO-SS	420
14, 15, 16	5/8	3/4-14	1-14	13	18	30	36	40	28	237	10-12 CLO-S	10-12 CLO-SS	280
18, 20	3/4	3/4-14	1 3/16-12	16	18	30	37	40	28	246	12 CLO-S	12 CLO-SS	280
18, 20	3/4	1/2-14	1 3/16-12	16	13	30	37	40	29	257	12-8 CLO-S	12-8 CLO-SS	420
18, 20	3/4	1-11 1/2	1 3/16-12	16	24	33	41	50	36	363	12-16 CLO-S	12-16 CLO-SS	210
22, 25	1	1-11 1/2	1 7/16-12	21	24	37	42	50	36	387	16 CLO-S	16 CLO-SS	210
22, 25	1	3/4-14	1 7/16-12	21	18	37	42	45	33	401	16-12 CLO-S	16-12 CLO-SS	280
28, 30, 32	1 1/4	1 1/4-11 1/2	1 11/16-12	26	32	41	45	61	46	469	20 CLO-S	20 CLO-SS	175
35, 38	1 1/2	1 1/2-11 1/2	2-12	32	38	48	49	67	52	603	24 CLO-S	24 CLO-SS	175

O-Lok® is delivered with NBR elastomeric seals as standard. For more details on other seal materials see page J73-J74.

Part numbers shown are part of our current manufacturing programme.

Imperial and metric parts may vary in hexagon dimensions.

$$\frac{\text{PN (bar)}}{10} = \text{PN (MPa)}$$

Pressure ratings – PN shown, apply to Steel and Stainless Steel versions of the product.

J

V87OMLO 45° male stud elbow

O-Lok® ORFS tube end/Male metric thread – O-ring (ISO 6149-2)
 SAE 52M0387 ISO 8434-3 SDE45

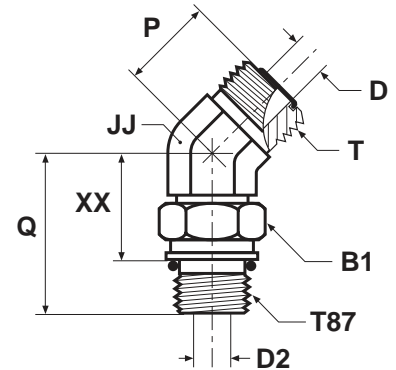

Tube O.D.		Thread metric T87	Thread UN/UNF-2A T	B1 mm	D mm	D2 mm	JJ mm	P mm	Q mm	XX mm	Weight (steel) g/1 piece	O-Lok® Steel	O-Lok® Stainless Steel	PN (bar)
mm	in.													
6	1/4	M12 1.5	9/16-18	17	5	4	14	16	30	19	44	4M12V87OMLOS	4M12V87OMLOSS	420
8, 10	5/16, 3/8	M16 1.5	11/16-16	22	7	7	19	19	33	19	82	6M16V87OMLOS	6M16V87OMLOSS	420
12	1/2	M18 1.5	13/16-16	24	10	9	19	20	37	23	110	8M18V87OMLOS	8M18V87OMLOSS	420
14, 15, 16	5/8	M22 1.5	1-14	27	13	12	27	23	43	29	190	10M22V87OMLOS	10M22V87OMLOSS	420
18, 20	3/4	M27 2	1 3/16-12	32	16	15	30	26	50	32	288	12M27V87OMLOS	12M27V87OMLOSS	420
22, 25	1	M33 2	1 7/16-12	41	21	20	36	30	52	34	300	16M33V87OMLOS	16M33V87OMLOSS	420
28, 30, 32	1 1/4	M42 2	1 11/16-12	50	26	26	41	32	54	35	444	20M42V87OMLOS	20M42V87OMLOSS	280
35, 38	1 1/2	M48 2	2-12	55	32	32	50	37	56	35	569	24M48V87OMLOS		280

O-Lok® is delivered with NBR elastomeric seals as standard. For more details on other seal materials see page J73–J74.

Part numbers shown are part of our current manufacturing programme.

Imperial and metric parts may vary in hexagon dimensions.

$$\frac{\text{PN (bar)}}{10} = \text{PN (MPa)}$$

Pressure ratings – PN shown, apply to Steel and Stainless Steel versions of the product.

V5OMLO 45° male stud elbow

O-Lok® ORFS tube end/Adjustable UN/UNF thread O-ring (ISO 11926)
SAE 520320

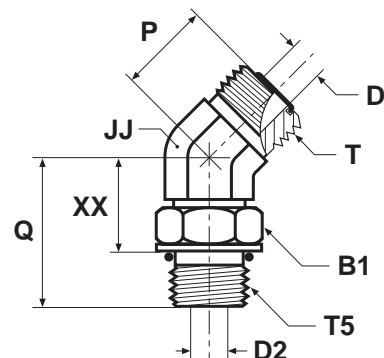

Tube O.D.		Thread UN/UNF-2A T5	Thread UN/UNF-2A T	B1	D	D2	JJ	P	Q	XX	Weight (steel) g/1 piece	O-Lok® Steel	O-Lok® Stainless Steel	PN (bar)
mm	in.			mm	mm	mm	mm	mm	mm	mm				
6	1/4	7/16-20	9/16-18	16	5	5	14	16	30	19	45	4V5OMLOS	4V5OMLOSS	630
6	1/4	9/16-18	9/16-18	19	5	8	19	17	33	21	76	4-6V5OMLOS	4-6V5OMLOSS	630
8, 10	5/16, 3/8	9/16-18	11/16-16	19	7	8	19	19	33	21	83	6V5OMLOS	6V5OMLOSS	630
8, 10	5/16, 3/8	7/16-20	11/16-16	16	7	5	19	19	31	20	64	6-4V5OMLOS	6-4V5OMLOSS	630
8, 10	5/16, 3/8	3/4-16	11/16-16	24	7	10	19	19	36	23	96	6-8V5OMLOS	6-8V5OMLOSS	630
12	1/2	3/4-16	13/16-16	24	10	10	19	20	36	23	117	8V5OMLOS	8V5OMLOSS	630
12	1/2	9/16-18	13/16-16	19	10	7	19	20	32	20	71	8-6 V5OLO-S	8-6V5OMLOSS	630
12	1/2	7/8-14	13/16-16	27	10	13	27	21	45	29	147	8-10V5OMLOS	8-10V5OMLOSS	420
14, 15, 16	5/8	7/8-14	1-14	27	13	13	27	23	45	29	194	10V5OMLOS	10V5OMLOSS	420
14, 15, 16	5/8	3/4-16	1-14	24	12	10	27	23	40	27	192	10-8 V5OLO-S	10-8V5OMLOSS	420
14, 15, 16	5/8	1 1/16-12	1-14	36	12	16	30	24	50	32	207	10-12 V5OLO-S	10-12V5OMLOSS	420
18, 20	3/4	1 1/16-12	1 3/16-12	35	16	16	30	26	50	32	294	12 V5OLO-S	12V5OMLOSS	420
18, 20	3/4	7/8-14	1 3/16-12	27	16	12	30	26	46	30	219	12-10 V5OLO-S	12-10V5OMLOSS	420
18, 20	3/4	1 5/16-12	1 3/16-12	41	16	21	37	30	52	34	322	12-16 V5OLO-S	12-16V5OMLOSS	420
22, 25	1	1 5/16-12	1 7/16-12	41	21	21	37	30	52	34	394	16 V5OLO-S	16V5OMLOSS	420
22, 25	1	1 1/16-12	1 7/16-12	36	21	16	36	30	52	33	337	16-12V5OMLOS	16-12V5OMLOSS	420
22, 25	1	1 5/8-12	1 7/16-12	48	21	31	41	32	54	35	511	16-20 V5OLO-S	16-20V5OMLOSS	420
28, 30, 32	1 1/4	1 5/8-12	1 11/16-12	48	26	26	41	32	54	35	447	20 V5OLO-S	20V5OMLOSS	350
35, 38	1 1/2	1 7/8-12	2-12	54	32	32	48	37	54	35	571	24 V5OLO-S	24V5OMLOSS	280

O-Lok® is delivered with NBR elastomeric seals as standard. For more details on other seal materials see page J73-J74.

Part numbers shown are part of our current manufacturing programme.

Imperial and metric parts may vary in hexagon dimensions.

$$\frac{\text{PN (bar)}}{10} = \text{PN (MPa)}$$

Pressure ratings – PN shown, apply to Steel and Stainless Steel versions of the product.

V4OMLO 45° male stud elbow

O-Lok® ORFS tube end/Adjustable BSPP thread O-ring + retaining ring (ISO 1179)

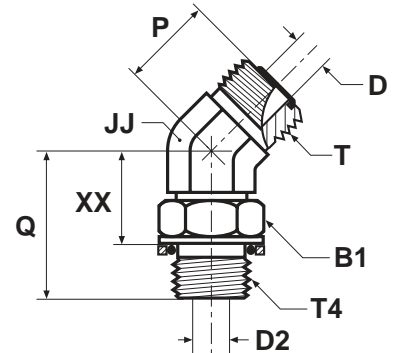

Tube O.D.		Thread BSPP T4	Thread UN/UNF-2A T	B1 mm	D mm	D2 mm	JJ mm	P mm	Q mm	XX mm	Weight (steel) g/1 piece	O-Lok® Steel	O-Lok® Stainless Steel	PN (bar)
mm	in.													
6	1/4	1/8	9/16-18	14	5	4	14	16	28	19	38	4V4OMLOS	4V4OMLOSS	250
6	1/4	1/4	9/16-18	19	5	8	19	17	33	21	43	4-4V4OMLOS	4-4V4OMLOSS	250
8, 10	5/16, 3/8	1/4	11/16-16	19	7	8	19	19	32	21	83	6V4OMLOS	6V4OMLOSS	250
8, 10	5/16, 3/8	3/8	11/16-16	22	7	10	19	19	34	23	95	6-6V4OMLOS	6-6V4OMLOSS	250
8, 10	5/16, 3/8	1/2	11/16-16	27	7	12	27	19	43	28	107	6-8V4OMLOS	6-8V4OMLOSS	250
12	1/2	3/8	13/16-16	22	10	10	19	20	34	23	117	8V4OMLOS	8V4OMLOSS	250
14, 15, 16	5/8	1/2	1-14	27	13	12	27	23	43	29	191	10V4OMLOS	10V4OMLOSS	250
14, 15, 16	5/8	3/4	1-14	36	13	16	30	24	46	31	227	10-12V4OMLOS	10-12V4OMLOSS	250
18, 20	3/4	3/4	1 3/16-12	36	16	16	30	26	46	31	294	12V4OMLOS	12V4OMLOSS	250
18, 20	3/4	1	1 3/16-12	41	16	22	36	30	51	34	325	12-16V4OMLOS	12-16V4OMLOSS	250
22, 25	1	1	1 7/16-12	41	21	22	36	30	51	34	394	16V4OMLOS	16V4OMLOSS	250
28, 30, 32	1 1/4	1 1/4	1 11/16-12	50	26	28	41	32	52	35	430	20V4OMLOS	20V4OMLOSS	210
35, 38	1 1/2	1 1/2	2-12	55	32	33	50	37	52	35	551	24V4OMLOS	24V4OMLOSS	140

O-Lok® is delivered with NBR elastomeric seals as standard. For more details on other seal materials see page J73-J74.

Part numbers shown are part of our current manufacturing programme.

Imperial and metric parts may vary in hexagon dimensions.

$$\frac{\text{PN (bar)}}{10} = \text{PN (MPa)}$$

Pressure ratings – PN shown, apply to Steel and Stainless Steel versions of the product.

V8OMLO 45° male stud elbow

O-Lok®ORFS tube end/Male metric thread – O-ring + retaining ring

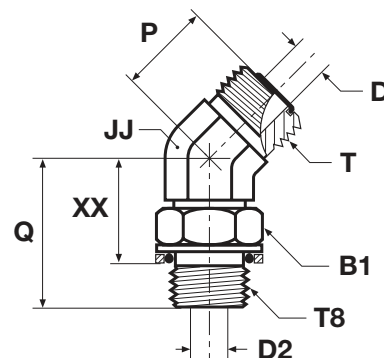

mm	Tube O.D. in.	Thread metric T8	Thread UN/UNF-2A T	B1 mm	D mm	D2 mm	JJ mm	P mm	Q mm	XX mm	Weight (steel) g/1 piece	O-Lok® Steel	PN (bar)
6	1/4	M12 1.5	9/16-18	17	5	4	14	16	30	20	44	4M12V8OMLOS	250
10	3/8	M16 1.5	11/16-16	19	7	7	19	19	33	22	82	6M16V8OMLOS	250
12	1/2	M14 1.5	13/16-16	17	10	6	19	20	31	20	92	8M14V8OMLOS	250
12	1/2	M18 1.5	13/16-16	22	10	9	19	20	37	25	110	8M18V8OMLOS	250
14, 15, 16	5/8	M18 1.5	1-14	27	13	9	27	24	34	27	160	10M18V8OMLOS	250
14, 15, 16	5/8	M22 1.5	1-14	27	13	12	27	23	43	30	190	10M22V8OMLOS	250
18, 20	3/4	M27 2	1 3/16-12	32	16	15	30	26	50	34	288	12M27V8OMLOS	250
22, 25	1	M33 2	1 7/16-12	38	21	20	36	30	52	36	300	16M33V8OMLOS	140
28, 30, 32	1 1/4	M42 2	1 11/16-12	50	26	26	41	32	54	37	444	20M42V8OMLOS	140
35, 38	1 1/2	M48 2	2-12	55	32	32	50	37	56	37	568	24M48V8OMLOS	140

O-Lok® is delivered with NBR elastomeric seals as standard. For more details on other seal materials see page J73–J74.

Part numbers shown are part of our current manufacturing programme.

Imperial and metric parts may vary in hexagon dimensions.

$$\frac{\text{PN (bar)}}{10} = \text{PN (MPa)}$$

J

S87OMLO Male stud branch tee

O-Lok® ORFS tube ends/Adjustable metric thread – O-ring (ISO 6149)
 SAE 52M0489 ISO 8434-3 SDBT

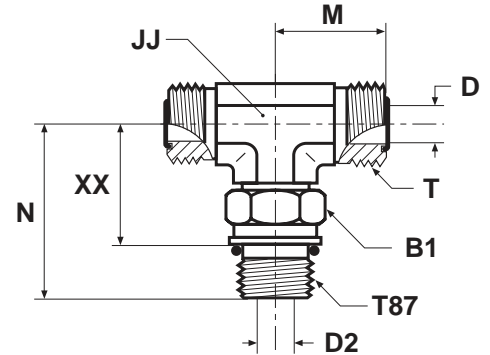

Tube O.D. mm	Tube O.D. in.	Thread metric T87	Thread UN/UNF-2A T	B1 mm	D mm	D2 mm	JJ mm	M mm	N mm	XX mm	Weight (steel) g/1 piece	O-Lok® Steel	O-Lok® Stainless Steel	PN (bar)
6	1/4	M12 1.5	9/16-18	17	5	4	14	22	33	22	66	4M12S87OMLOS	4M12S87OMLOSS	420
8, 10	5/16, 3/8	M16 1.5	11/16-16	22	7	7	19	25	37	27	131	6M16S87OMLOS	6M16S87OMLOSS	420
12	1/2	M18 1.5	13/16-16	24	10	9	19	28	41	27	187	8M18S87OMLOS	8M18S87OMLOSS	420
14, 15, 16	5/8	M22 1.5	1-14	27	13	12	27	33	49	34	283	10M22S87OMLOS	10M22S87OMLOSS	420
18, 20	3/4	M27 2	1 3/16-12	32	16	15	30	37	55	37	549	12M27S87OMLOS	12M27S87OMLOSS	420
22, 25	1	M33 2	1 7/16-12	41	21	20	36	42	59	41	565	16M33S87OMLOS	16M33S87OMLOSS	420
28, 30, 32	1 1/4	M42 2	1 11/16-12	50	26	26	41	45	62	44	824	20M42S87OMLOS	20M42S87OMLOSS	280
35, 38	1 1/2	M48 2	2-12	55	32	32	48	49	69	48	940	24M48S87OMLOS		280

O-Lok® is delivered with NBR elastomeric seals as standard. For more details on other seal materials see page J73–J74.

Part numbers shown are part of our current manufacturing programme.

Imperial and metric parts may vary in hexagon dimensions.

$$\frac{\text{PN (bar)}}{10} = \text{PN (MPa)}$$

Pressure ratings – PN shown, apply to Steel and Stainless Steel versions of the product.

S50MLO Male stud branch tee

O-Lok® ORFS tube end/Adjustable UN/UNF thread O-ring (ISO 11926)
SAE 520429

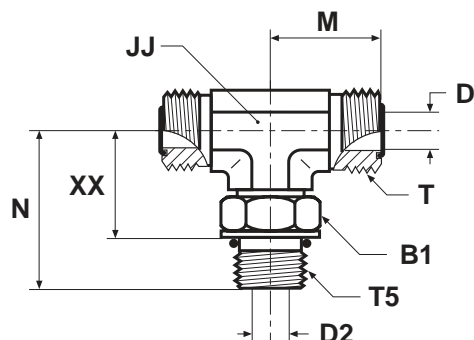

Tube O.D.		Thread UN/UNF-2A T5	Thread UN/UNF-2A T	B1 mm	D mm	D2 mm	JJ mm	M mm	N mm	XX mm	Weight (steel) g/1 piece	O-Lok® Steel	O-Lok® Stainless Steel	PN (bar)
mm	in.													
6	1/4	7/16-20	9/16-18	16	5	5	14	22	33	22	67	4S50MLOS	4 S50LO-SS	420
8, 10	5/16, 3/8	9/16-18	11/16-16	19	7	8	19	25	37	25	131	6S50MLOS	6 S50LO-SS	420
8, 10	5/16, 3/8	3/4-16	11/16-16	24	10	10	19	26	41	27	160	6-6-8 S50LO-S	6-6-8 S50LO-SS	420
12	1/2	3/4-16	13/16-16	24	10	10	19	28	41	27	187	8 S50LO-S	8 S50LO-SS	420
14, 15, 16	5/8	7/8-14	1-14	27	13	12	27	33	50	34	279	10 S50LO-S	10 S50LO-SS	420
18, 20	3/4	1 1/16-12	1 3/16-12	36	16	16	30	37	55	37	441	12 S50LO-S	12 S50LO-SS	420
18, 20	3/4	1 5/16-12	1 3/16-12	42	18	21	37	42	60	41	500	12-12-16 S50LO-S	12-12-16 S50LO-SS	380
22, 25	1	1 5/16-12	1 7/16-12	41	21	21	37	42	60	41	539	16 S50LO-S	16 S50LO-SS	380
28, 30, 32	1 1/4	1 5/8-12	1 11/16-12	48	26	26	41	45	62	44	851	20 S50LO-S		280
35, 38	1 1/2	1 7/8-12	2-12	54	32	32	48	49	66	47	942	24 S50LO-S		280

O-Lok® is delivered with NBR elastomeric seals as standard. For more details on other seal materials see page J73–J74.

Part numbers shown are part of our current manufacturing programme.

Imperial and metric parts may vary in hexagon dimensions.

$$\frac{\text{PN (bar)}}{10} = \text{PN (MPa)}$$

Pressure ratings – PN shown, apply to Steel and Stainless Steel versions of the product.



S4OMLO Male stud branch tee

O-Lok® ORFS tube end/Adjustable BSPB thread O-ring + retaining ring (ISO 1179)

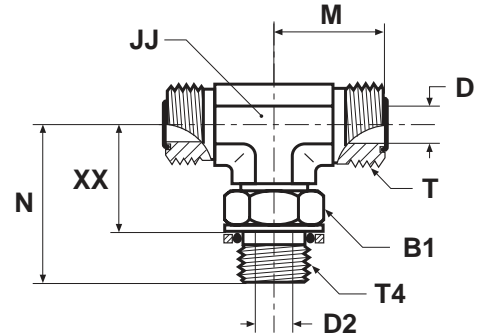

Tube O.D.		Thread BSPB T4	Thread UN/UNF-2A T	B1 mm	D mm	D2 mm	JJ mm	M mm	N mm	XX mm	Weight (steel) g/1 piece	O-Lok® Steel	O-Lok® Stainless Steel	PN (bar)
mm	in.													
6	1/4	1/8	9/16-18	14	5	4	14	22	30	22	69	4S4OMLOS	4S4OMLOSS	250
6	1/4	1/4	9/16-18	19	5	8	19	24	36	25	97	4-4-4S4OMLOS	4-4-4S4OMLOSS	250
8, 10	5/16, 3/8	1/4	11/16-16	19	7	8	19	25	36	25	127	6S4OMLOS	6S4OMLOSS	250
8, 10	5/16, 3/8	3/8	11/16-16	22	7	10	19	27	38	27	126	6-6-6S4OMLOS	6-6-6S4OMLOSS	250
12	1/2	3/8	13/16-16	22	10	10	19	28	38	27	146	8S4OMLOS	8S4OMLOSS	250
12	1/2	1/2	13/16-16	27	10	12	27	31	49	34	174	8-8-8S4OMLOS	8-8-8S4OMLOSS	250
14, 15, 16	5/8	1/2	1-14	27	13	12	27	33	49	34	288	10S4OMLOS	10S4OMLOSS	250
14, 15, 16	5/8	3/4	1-14	36	13	16	30	36	52	37	314	10-10-12S4OMLOS	10-10-12S4OMLOSS	250
18, 20	3/4	3/4	1 3/16-12	36	16	16	30	37	52	37	531	12S4OMLOS	12S4OMLOSS	250
22, 25	1	1	1 7/16-12	41	21	22	36	42	58	41	600	16S4OMLOS	16S4OMLOSS	250
28, 30, 32	1 1/4	1 1/4	1 11/16-12	50	26	28	41	45	61	44	850	20S4OMLOS	20S4OMLOSS	210
35, 38	1 1/2	1 1/2	2-12	55	32	33	50	49	65	47	940	24S4OMLOS		140

O-Lok® is delivered with NBR elastomeric seals as standard. For more details on other seal materials see page J73-J74.

Part numbers shown are part of our current manufacturing programme.

Imperial and metric parts may vary in hexagon dimensions.

$$\frac{\text{PN (bar)}}{10} = \text{PN (MPa)}$$

Pressure ratings – PN shown, apply to Steel and Stainless Steel versions of the product.

S8OMLO Male stud branch tee

O-Lok® ORFS tube end/Adjustable metric thread – O-ring + retaining ring

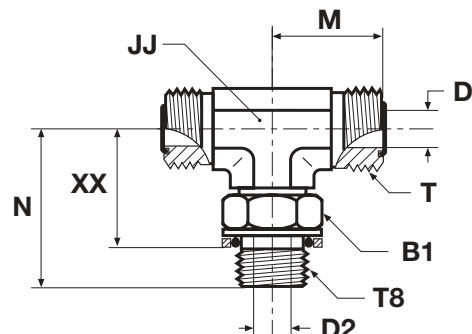

Tube O.D. mm	Tube O.D. in.	Thread metric T8	Thread UN/UNF-2A T	B1 mm	D mm	D2 mm	JJ mm	M mm	N mm	XX mm	Weight (steel) g/1 piece	O-Lok® Steel	PN (bar)
6	1/4	M12 1.5	9/16-18	17	5	4	14	22	33	23	66	4M12S8OMLOS	250
8, 10	5/16, 3/8	M16 1.5	11/16-16	19	7	7	19	25	37	26	131	6M16S8OMLOS	250
12	1/2	M18 1.5	13/16-16	22	10	9	19	28	41	29	187	8M18S8OMLOS	250
14, 15, 16	5/8	M22 1.5	1-14	27	13	12	27	33	49	35	283	10M22S8OMLOS	250
18, 20	3/4	M27 2	1 3/16-12	32	16	15	30	37	55	39	550	12M27S8OMLOS	250
22, 25	1	M33 2	1 7/16-12	38	21	20	36	42	59	43	566	16M33S8OMLOS	140
28, 30, 32	1 1/4	M42 2	1 11/16-12	50	26	26	41	45	62	46	824	20M42S8OMLOS	140
35, 38	1 1/2	M48 2	2-12	55	32	32	48	49	69	49	940	24M48S8OMLOS	140

O-Lok® is delivered with NBR elastomeric seals as standard. For more details on other seal materials see page J73–J74.

Part numbers shown are part of our current manufacturing programme.

Imperial and metric parts may vary in hexagon dimensions.

$$\frac{\text{PN (bar)}}{10} = \text{PN (MPa)}$$



R87OMLO Male stud run tee

O-Lok® ORFS tube ends/Adjustable metric thread – O-ring (ISO 6149)
 SAE 52M0488 ISO 8434-3 SDRT

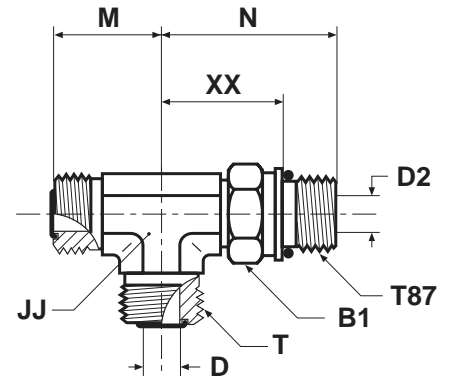

Tube O.D. mm	Tube O.D. in.	Thread metric T87	Thread UN/UNF-2A T	B1 mm	D mm	D2 mm	JJ mm	M mm	N mm	XX mm	Weight (steel) g/1 piece	O-Lok® Steel	O-Lok® Stainless Steel	PN (bar)
6	1/4	M12 1.5	9/16-18	17	5	4	14	22	33	22	66	4M12R87OMLOS	4M12R87OMLOSS	420
8, 10	5/16, 3/8	M16 1.5	11/16-16	22	7	7	19	25	38	27	131	6M16R87OMLOS	6M16R87OMLOSS	420
12	1/2	M18 1.5	13/16-16	24	10	9	19	28	41	27	187	8M18R87OMLOS	8M18R87OMLOSS	420
14, 15, 16	5/8	M22 1.5	1-14	27	13	12	27	33	49	34	283	10M22R87OMLOS	10M22R87OMLOSS	420
18, 20	3/4	M27 2	1 3/16-12	32	16	15	30	37	55	37	549	12M27R87OMLOS	12M27R87OMLOSS	420
22, 25	1	M33 2	1 7/16-12	41	21	20	36	42	59	41	565	16M33R87OMLOS	16M33R87OMLOSS	420
28, 30, 32	1 1/4	M42 2	1 11/16-12	50	26	26	41	45	63	44	824	20M42R87OMLOS	20M42R87OMLOSS	280
35, 38	1 1/2	M48 2	2-12	55	32	32	48	49	69	47	940	24M48R87OMLOS		280

O-Lok® is delivered with NBR elastomeric seals as standard. For more details on other seal materials see page J73–J74.

Part numbers shown are part of our current manufacturing programme.

Imperial and metric parts may vary in hexagon dimensions.

$$\frac{\text{PN (bar)}}{10} = \text{PN (MPa)}$$

Pressure ratings – PN shown, apply to Steel and Stainless Steel versions of the product.

R50MLO Male stud run tee

O-Lok® ORFS tube end/Adjustable UN/UNF thread O-ring (ISO 11926)
SAE 520428

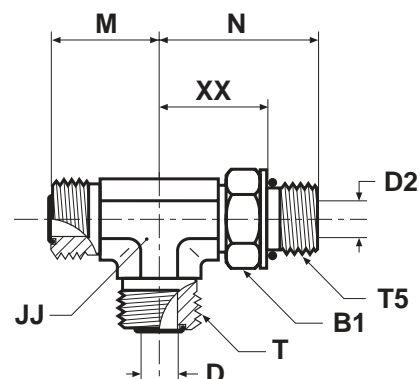

Tube O.D.		Thread UN/UNF-2A T5	Thread UN/UNF-2A T	B1 mm	D mm	D2 mm	JJ mm	M mm	N mm	XX mm	Weight (steel) g/1 piece	O-Lok® Steel	O-Lok® Stainless Steel	PN (bar)
mm	in.											O-Lok® Steel	O-Lok® Stainless Steel	
6	1/4	7/16-20	9/16-18	16	5	5	14	22	33	22	67	4 R50LO-S	4 R50LO-SS	420
8, 10	5/16, 3/8	9/16-18	11/16-16	19	7	8	19	25	37	25	131	6R50MLOS	6 R50LO-SS	420
12	1/2	3/4-16	13/16-16	24	10	10	19	28	41	27	187	8 R50LO-S	8 R50LO-SS	420
14, 15, 16	5/8	7/8-14	1-14	27	13	13	27	33	50	34	288	10 R50LO-S	10 R50LO-SS	420
18, 20	3/4	1 1/16-12	1 3/16-12	35	16	16	30	37	55	37	558	12 R50LO-S	12 R50LO-SS	420
18, 20	3/4	1 5/16-12	1 3/16-12	41	16	21	36	41	60	41	560	12-16-12 R50LO-S	12-16-12 R50LO-SS	380
22, 25	1	1 5/16-12	1 7/16-12	41	21	21	36	42	60	41	566	16R50MLOS	16 R50LO-SS	380
28, 30, 32	1 1/4	1 5/8-12	1 11/16-12	48	26	26	41	45	62	44	825	20 R50LO-S	20 R50LO-SS	280
35, 38	1 1/2	1 7/8-12	2-12	54	32	32	48	49	66	47	942	24 R50LO-S	24 R50LO-SS	280

O-Lok® is delivered with NBR elastomeric seals as standard. For more details on other seal materials see page J73-J74.

Part numbers shown are part of our current manufacturing programme.

Imperial and metric parts may vary in hexagon dimensions.

$$\frac{\text{PN (bar)}}{10} = \text{PN (MPa)}$$

Pressure ratings – PN shown, apply to Steel and Stainless Steel versions of the product.



R4OMLO Male stud run tee

O-Lok® ORFS tube ends/Adjustable BSPP thread O-ring + retaining ring (ISO 1179)

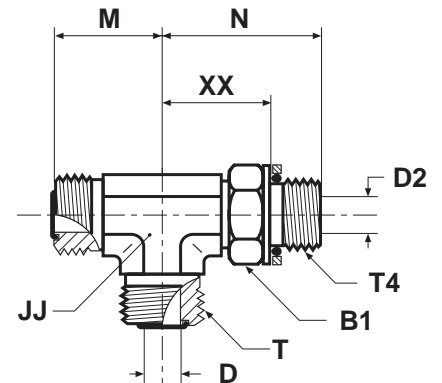

Tube O.D.		Thread BSPP T4	Thread UN/UNF-2A T	B1 mm	D mm	D2 mm	JJ mm	M mm	N mm	XX mm	Weight (steel) g/1 piece	O-Lok® Steel	O-Lok® Stainless Steel	PN (bar)
mm	in.													
6	1/4	1/8	9/16-18	14	5	4	14	22	30	22	69	4R4OMLOS	4R4OMLOSS	250
6	1/4	1/4	9/16-18	19	5	8	19	24	36	25	97	4-4-4R4OMLOS	4-4-4R4OMLOSS	250
8, 10	5/16, 3/8	1/4	11/16-16	19	7	8	19	25	36	25	127	6R4OMLOS	6R4OMLOSS	250
8, 10	5/16, 3/8	3/8	11/16-16	22	7	10	19	27	38	27	126	6-6-6R4OMLOS	6-6-6R4OMLOSS	250
12	1/2	3/8	13/16-16	22	10	10	19	28	38	27	146	8R4OMLOS	8R4OMLOSS	250
12	1/2	1/2	13/16-16	27	10	12	27	31	49	34	174	8-8-8R4OMLOS	8-8-8R4OMLOSS	250
14, 15, 16	5/8	1/2	1-14	27	13	12	27	33	49	34	288	10R4OMLOS	10R4OMLOSS	250
16		3/4	1-14	36	13	16	30	36	52	37	314	10-12-10R4OMLOS	10-12-10R4OMLOSS	250
18, 20	3/4	3/4	1 3/16-12	36	16	16	30	37	52	37	531	12R4OMLOS	12R4OMLOSS	250
18, 20	3/4	1	1 3/16-12	41	16	22	36	41	58	41	559	12-16-12R4OMLOS	12-16-12R4OMLOSS	250
22, 25	1	1	1 7/16-12	41	21	22	36	42	58	41	553	16R4OMLOS	16R4OMLOSS	250
28, 30, 32	1 1/4	1 1/4	1 11/16-12	50	26	28	41	45	61	44	824	20R4OMLOS	20R4OMLOSS	210
35, 38	1 1/2	1 1/2	2-12	55	32	32	50	49	65	47	940	24R4OMLOS		140

O-Lok® is delivered with NBR elastomeric seals as standard. For more details on other seal materials see page J73–J74.

Part numbers shown are part of our current manufacturing programme.

Imperial and metric parts may vary in hexagon dimensions.

$$\frac{\text{PN (bar)}}{10} = \text{PN (MPa)}$$

Pressure ratings – PN shown, apply to Steel and Stainless Steel versions of the product.

R8OMLO Male stud run tee

O-Lok® ORFS tube end/Adjustable metric thread – O-ring + retaining ring

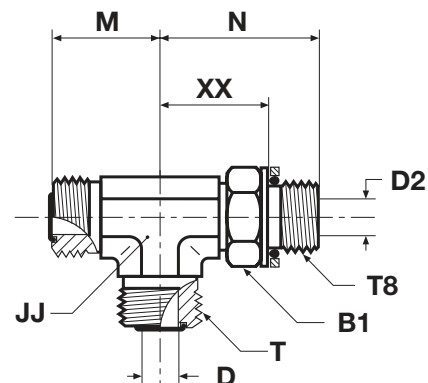

Tube O.D. mm	Tube O.D. in.	Thread metric T8	Thread UN/UNF-2A T	B1 mm	D mm	D2 mm	JJ mm	M mm	N mm	XX mm	Weight (steel) g/1 piece	O-Lok® Steel	PN (bar)
6	1/4	M12 1.5	9/16-18	17	5	4	14	22	33	23	66	4M12R8OMLOS	250
8, 10	5/16, 3/8	M16 1.5	11/16-16	19	7	7	19	25	38	26	131	6M16R8OMLOS	250
12	1/2	M18 1.5	13/16-16	22	10	9	19	28	41	29	187	8M18R8OMLOS	250
14, 15, 16	5/8	M22 1.5	1-14	27	13	12	27	33	49	35	283	10M22R8OMLOS	250
18, 20	3/4	M27 2	1 3/16-12	32	16	15	30	37	55	39	550	12M27R8OMLOS	250
22, 25	1	M33 2	1 7/16-12	38	21	20	36	42	59	43	566	16M33R8OMLOS	140
28, 30, 32	1 1/4	M42 2	1 11/16-12	50	26	26	41	45	63	46	824	20M42R8OMLOS	140
35, 38	1 1/2	M48 2	2-12	55	32	32	48	49	69	49	940	24M48R8OMLOS	140

O-Lok® is delivered with NBR elastomeric seals as standard. For more details on other seal materials see page J73–J74.

Part numbers shown are part of our current manufacturing programme.

Imperial and metric parts may vary in hexagon dimensions.

$$\frac{\text{PN (bar)}}{10} = \text{PN (MPa)}$$



G87MLO Pressure gauge fitting

O-Lok® ORFS tube end/Female metric thread – O-ring (ISO 6149-1)

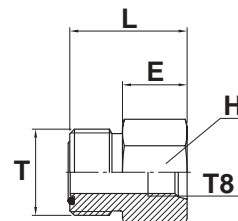

Tube O.D.		Thread metric T8	Thread UN/UNF-2A T	E mm	H mm	L mm	Weight (steel) g/1 piece	O-Lok® Steel	O-Lok® Stainless Steel	PN (bar)
mm	in.									
6	1/4	M14 1.5	9/16-18	19	19	29	20	4M14G87MLOS	4M14G87MLOSS	630
8, 10	5/16, 3/8	M14 1.5	11/16-18	19	19	30	44	6M14G87MLOS	6M14G87MLOSS	630
12	1/2	M14 1.5	13/16-16	19	22	32	66	8M14G87MLOS	8M14G87MLOSS	630
14, 15, 16	5/8	M14 1.5	1-14	19	27	35	82	10M14G87MLOS	10M14G87MLOSS	420
18, 20	3/4	M14 1.5	1 3/16-12	19	32	36	104	12M14G87MLOS	12M14G87MLOSS	420

O-Lok® is delivered with NBR elastomeric seals as standard. For more details on other seal materials see page J73–J74.

Part numbers shown are part of our current manufacturing programme.

Imperial and metric parts may vary in hexagon dimensions.

$$\frac{\text{PN (bar)}}{10} = \text{PN (MPa)}$$

Pressure ratings – PN shown, apply to Steel and Stainless Steel versions of the product.

G4MLOSMO Pressure gauge connector

O-Lok® ORFS tube end/Female BSPG gauge thread (ISO 1179-1)

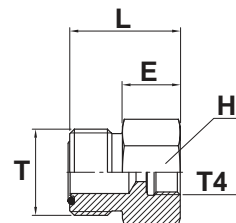

mm	Tube O.D.		Thread BSPG T4	Thread UN/UNF-2A T	E mm	H mm	L mm	Weight (steel) g/1 piece	O-Lok®		PN (bar)
	mm	in.							Steel	Stainless Steel	
6		1/4	1/4	9/16-18	19	17	27	32	4-4G4MLOSMO	4-4G4MLOSSMO	400
6		1/4	1/2	9/16-18	27	30	37	80	4-8G4MLOSMO	4-8G4MLOSSMO	400
8, 10		5/16, 3/8	1/4	11/16-16	17	19	28	49	6G4MLOSMO	6G4MLOSSMO	400
8, 10		5/16, 3/8	1/2	11/16-16	27	30	38	107	6-8G4MLOSMO	6-8G4MLOSSMO	400
12		1/2	1/4	13/16-16	17	22	30	60	8-4G4MLOSMO	8-4G4MLOSSMO	280
12		1/2	1/2	13/16-16	27	30	40	80	8-8G4MLOSMO	8-8G4MLOSSMO	280

O-Lok® is delivered with NBR elastomeric seals as standard. For more details on other seal materials see page J73–J74.

Part numbers shown are part of our current manufacturing programme.

Imperial and metric parts may vary in hexagon dimensions.

$$\frac{\text{PN (bar)}}{10} = \text{PN (MPa)}$$

Pressure ratings – PN shown, apply to Steel and Stainless Steel versions of the product.

J

TT4ML Test point connection

O-Lok® ORFS swivel female end/Female BSPP thread (ISO 1179-1)
for EMA3 test point

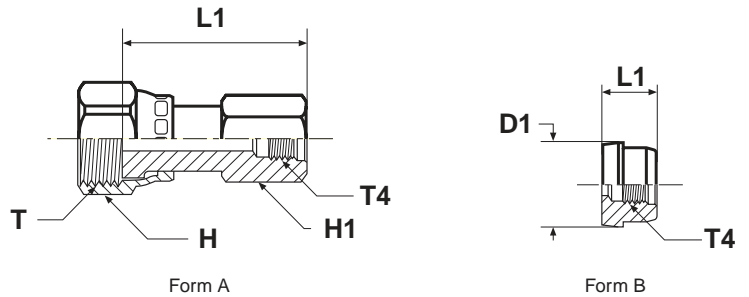

Form B has to be assembled with a nut BMLS/BLS.

Thread UN/UNF-2B T	Thread BSPP T4	D1 mm	H mm	H1 mm	L1 mm	Weight (steel) g/1 piece	Form	O-Lok® Steel	O-Lok® Stainless Steel	PN (bar)
9/16-16	1/4	—	17	19	38	60	A	4TT4MLS	4TT4MLSS	420
11/16-16	1/4	—	22	19	41	74	A	6TT4MLS	6TT4MLSS	420
13/16-16	1/4	—	24	19	43	91	A	8TT4MLS	8TT4MLSS	420
—	1/4	23	—	—	18	30	B	10TT4LS	10TT4MLSS	420
—	1/4	28	—	—	18	48	B	12TT4LS	12TT4MLSS	420
—	1/4	34	—	—	18	95	B	16TT4LS	16TT4MLSS	420
—	1/4	41	—	—	18	130	B	20TT4LS	20TT4MLSS	280
—	1/4	49	—	—	18	189	B	24TT4LS	24TT4MLSS	280

Part numbers shown are part of our current manufacturing programme.

Imperial and metric parts may vary in hexagon dimensions.

$$\frac{\text{PN (bar)}}{10} = \text{PN (MPa)}$$

Pressure ratings – PN shown, apply to Steel and Stainless Steel versions of the product.

TT8ML Test point connection

O-Lok® ORFS female swivel end / Metric female thread
 (Metric female thread designed for use with EMA3 connections only)

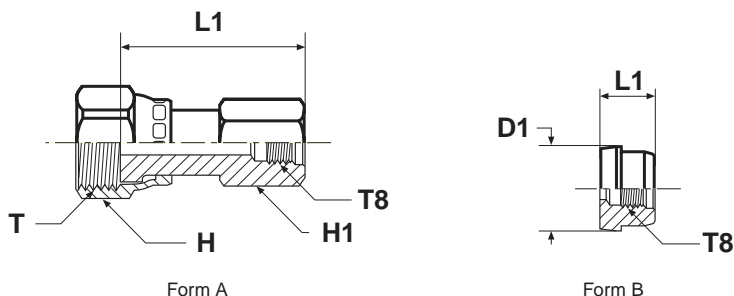

Form B has to be assembled with a nut BMLS/BLS.

Thread UN/UNF-2B T	Thread metric T8	D1 mm	H mm	H1 mm	L1 mm	Weight (steel) g/1 piece	Form	O-Lok® Steel	O-Lok® Stainless Steel	PN (bar)
9/16-16	M10 1	—	17	19	37	86	A	4TT8MLS	4TT8MLSS	420
11/16-16	M10 1	—	22	19	39	86	A	6TT8MLS	6TT8MLSS	420
13/16-16	M10 1	—	24	19	43	123	A	8TT8MLS	8TT8MLSS	420
—	M10 1	23	—	—	16	40	B	10TT8LS	10TT8MLSS	420
—	M10 1	28	—	—	16	60	B	12TT8LS	12TT8MLSS	420
—	M10 1	34	—	—	16	85	B	16TT8LS	16TT8MLSS	420
—	M10 1	41	—	—	16	133	B	20TT8LS	20TT8MLSS	280
—	M10 1	48	—	—	16	193	B	24TT8LS	24TT8MLSS	280

Part numbers shown are part of our current manufacturing programme.

Imperial and metric parts may vary in hexagon dimensions.

$$\frac{\text{PN (bar)}}{10} = \text{PN (MPa)}$$

Pressure ratings – PN shown, apply to Steel and Stainless Steel versions of the product.



TTP4ML Test point connection

O-Lok® ORFS female swivel end/EMA3 test point

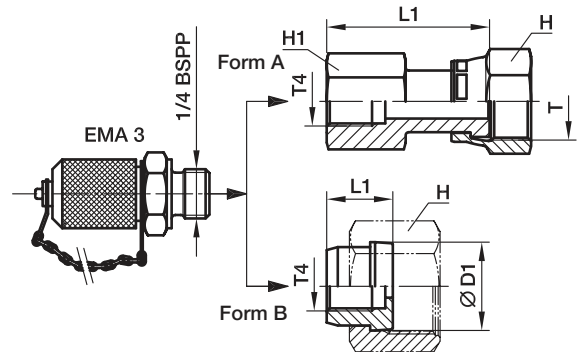

Form B versions delivered complete with BMLS nut.

Thread UN/UNF-2B T	Thread BSPP T4	D1 mm	H mm	H1 mm	L1 mm	Weight (steel) g/1 piece	Form	O-Lok® Steel	PN (bar)
9/16-16	1/4	—	17	19	38	150	A	4TTP4MLS	420
11/16-16	1/4	—	22	19	41	164	A	6TTP4MLS	420
13/16-16	1/4	—	24	19	43	181	A	8TTP4MLS	420
—	1/4	23	30	—	18	120	B	10TTP4LS	420
—	1/4	28	36	—	18	138	B	12TTP4LS	420
—	1/4	34	41	—	18	185	B	16TTP4LS	420
—	1/4	41	50	—	18	200	B	20TTP4LS	280
—	1/4	49	60	—	18	279	B	24TTP4LS	280

O-Lok® is delivered with NBR elastomeric seals as standard. For more details on other seal materials see page J73–J74.

Part numbers shown are part of our current manufacturing programme.

Imperial and metric parts may vary in hexagon dimensions.

$$\frac{\text{PN (bar)}}{10} = \text{PN (MPa)}$$

R6P4MLO Test point connection

O-Lok® ORFS end/O-Lok® ORFS female swivel end/EMA3 test point

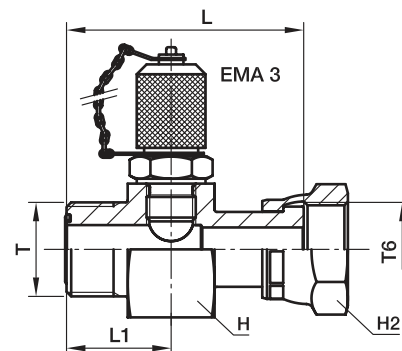

Tube O.D.		Thread UN/UNF-2A T	Thread UN/UNF-2B T6	L mm	L1 mm	H mm	H2 mm	Weight (steel) g/1 piece	O-Lok® Steel	PN (bar)
mm	in.									
6	1/4	9/16-18	9/16-18	50	22	36	17	270	4-4R6P4MLOS	420
8, 10	5/16, 3/8	11/16-16	11/16-16	53	23	36	22	300	6-4R6P4MLOS	420
12	1/2	13/16-16	13/16-16	58	25	36	24	308	8-4R6P4MLOS	420
14, 15, 16	5/8	1-14	1-14	64	27	36	30	337	10-4R6P4MLOS	420
18, 20	3/4	1 3/16-12	1 3/16-12	68	29	41	36	416	12-4R6P4MLOS	420
25	1	1 7/16-12	1 7/16-12	71	29	46	41	506	16-4R6P4MLOS	420
28, 30, 32	1 1/4	1 11/16-12	1 11/16-12	73	29	50	50	691	20-4R6P4MLOS	280
35, 38	1 1/2	2-12	2-12	74	29	60	60	995	24-4R6P4MLOS	280

O-Lok® is delivered with NBR elastomeric seals as standard. For more details on other seal materials see page J73–J74.

Part numbers shown are part of our current manufacturing programme.

Imperial and metric parts may vary in hexagon dimensions.

$$\frac{\text{PN (bar)}}{10} = \text{PN (MPa)}$$

J

LOHB3* Braze connector

O-Lok® ORFS tube end/Braze socket

SAE 520104 / SAE 52M0104 ISO 8434-3 BRS

(*Parts delivered oil dipped finish only – steel)

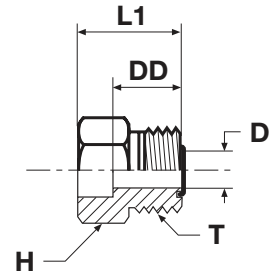

Tube O.D.	Thread UN/UNF-2A T	D mm	DD mm	H in.	H mm	L1 mm	Weight (steel) g/1 piece	O-Lok®		PN (bar)
								Steel	Stainless Steel	
6	9/16-18	05	14	—	17	22	023	4-6MMLOHB3S		420
	9/16-18	5	13	5/8	—	22	24	4 LOHB3-S	4 LOHB3-SS	420
	9/16-18	5	13	5/8	—	22	23	4-6 LOHB3-S	4-6 LOHB3-SS	420
	11/16-16	7	14	3/4	—	23	36	6 LOHB3-S	6 LOHB3-SS	420
	11/16-16	7	14	3/4	—	23	42	6-4 LOHB3-S	6-4 LOHB3-SS	420
	11/16-16	7	14	3/4	—	23	36	6-8 LOHB3-S	6-8 LOHB3-SS	420
	11/16-16	7	15	—	19	—	23	6-10 LOHB3-S	6-10 LOHB3-SS	420
12	13/16-16	10	16	—	22	25	42	8-12MMLOHB3S		420
	13/16-16	10	16	7/8	—	25	44	8 LOHB3-S	8 LOHB3-SS	420
	13/16-16	10	16	7/8	—	25	58	8-4 LOHB3-S	8-4 LOHB3-SS	420
	13/16-16	10	16	7/8	—	25	43	8-6 LOHB3-S	8-6 LOHB3-SS	420
	13/16-16	10	16	7/8	—	25	42	8-10 LOHB3-S	8-10 LOHB3-SS	420
	13/16-16	10	17	1 1/16	—	30	74	8-12 LOHB3-S	8-12 LOHB3-SS	420
16	1-14	13	19	—	27	27	101	10-16MMLOHB3S		420
	1-14	13	19	1 1/16	—	27	104	10 LOHB3-S	10 LOHB3-SS	420
	1-14	13	19	1 1/16	—	27	99	10-6 LOHB3-S	10-6 LOHB3-SS	420
	1-14	13	19	1 1/16	—	27	96	10-8 LOHB3-S	10-8 LOHB3-SS	420
	1-14	13	19	1 1/16	—	31	97	10-12 LOHB3-S	10-12 LOHB3-SS	420
20	1 3/16-12	16	21	—	32	34	144	12-20MMLOHB3S		420
	1 3/16-12	16	21	1 1/4	—	34	149	12 LOHB3-S	12 LOHB3-SS	420
	1 3/16-12	16	21	1 1/4	—	30	174	12-8 LOHB3-S	12-8 LOHB3-SS	420
	1 3/16-12	16	21	1 1/4	—	30	171	12-10 LOHB3-S	12-10 LOHB3-SS	420
	1 3/16-12	16	21	1 1/2	—	35	220	12-16 LOHB3-S	12-16 LOHB3-SS	420
25	1 7/16-12	21	25	—	41	39	218	16-25MMLOHB3S		420
	1 7/16-12	21	25	1 1/2	—	39	225	16 LOHB3-S	16 LOHB3-SS	420
	1 7/16-12	21	25	1 1/2	—	33	237	16-8 LOHB3-S	16-8 LOHB3-SS	420
	1 7/16-12	21	25	1 1/2	—	37	228	16-12 LOHB3-S	16-12 LOHB3-SS	420
	1 7/16-12	21	25	1 3/4	—	39	276	16-20 LOHB3-S	16-20 LOHB3-SS	420
30	1 11/16-12	26	25	—	46	39	269	20-30MMLOHB3S		280
	1 11/16-12	26	25	1 3/4	—	39	278	20 LOHB3-S	20 LOHB3-SS	280
	1 11/16-12	26	25	1 3/4	—	39	278	20-16 LOHB3-S	20-16 LOHB3-SS	280
	1 11/16-12	26	25	2 1/8	—	39	371	20-24 LOHB3-S	20-24 LOHB3-SS	280
38	2-12	32	25	—	55	39	374	24-38MMLOHB3S		280
	2-12	32	25	2 1/8	—	39	384	24 LOHB3-S	24 LOHB3-SS	280
	2-12	32	25	2 1/8	—	39	442	24-20 LOHB3-S	24-20 LOHB3-SS	280

O-Lok® is delivered with NBR elastomeric seals as standard. For more details on other seal materials see page J73–J74.

Part numbers shown are part of our current manufacturing programme.

Imperial and metric parts may vary in hexagon dimensions.

$$\frac{\text{PN (bar)}}{10} = \text{PN (MPa)}$$

Pressure ratings – PN shown, apply to Steel and Stainless Steel versions of the product.

FNML Cap

O-Lok® ORFS Female swivel cap end
SAE 520112

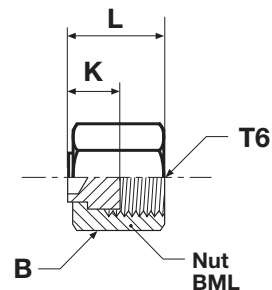

Thread UN/UNF-2B T6	B mm	K mm	L mm	Weight (steel) g/1 piece	O-Lok® Steel	O-Lok® Stainless Steel	PN (bar)
9/16-18	17	9	17	6	4 FNL-S	4FNMLSS	630
11/16-16	22	11	18	10	6FNMLS	6FNMLSS	630
13/16-16	24	12	22	11	8FNMLS	8FNMLSS	630
1-14	30	14	25	31	10FNMLS	10FNMLSS	420
1 3/16-12	36	15	27	52	12FNMLS	12FNMLSS	420
1 7/16-12	41	16	29	81	16FNMLS	16FNMLSS	420
1 11/16-12	48	15	29	129	20 FNL-S	20FNMLSS	280
2-12	57	15	29	189	24 FNL-S	24FNMLSS	280
2 1/2-12	73	20	37	390	32 FNL-S		200

Part numbers shown are part of our current manufacturing programme.

Imperial and metric parts may vary in hexagon dimensions.

$$\frac{\text{PN (bar)}}{10} = \text{PN (MPa)}$$

Pressure ratings – PN shown, apply to Steel and Stainless Steel versions of the product.

J

PNMLO Plug

O-Lok® ORFS tube end plug
SAE 520109

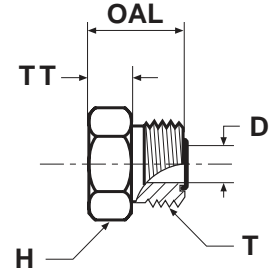

Tube O.D.		Thread UN/UNF-2A T	D mm	H mm	OAL mm	TT mm	Weight (steel) g/1 piece	O-Lok® Steel	O-Lok® Stainless Steel	PN (bar)
mm	in.									
6	1/4	9/16-18	5	16	17	5	18	4 PNLO-S	4PNMLOSS	630
8, 10	5/16, 3/8	11/16-16	7	19	19	8	34	6PNMLOS	6PNMLOSS	630
12	1/2	13/16-16	10	22	22	9	45	8PNMLOS	8PNMLOSS	630
14, 15, 16	5/8	1-14	13	27	26	10	91	10 PNLO-S	10PNMLOSS	420
18, 20	3/4	1 3/16-12	16	32	27	10	138	12PNMLOS	12PNMLOSS	420
22, 25	1	1 7/16-12	21	38	28	10	203	16 PNLO-S	16PNMLOSS	420
28, 30, 32	1 1/4	1 11/16-12	26	45	28	10	266	20 PNLO-S	20PNMLOSS	420
35, 38	1 1/2	2-12	32	54	28	10	369	24 PNLO-S	24PNMLOSS	350
50	2	2 1/2-12	45	70	35	13	580	32 PNLO-S	32PNMLOSS	200

O-Lok® is delivered with NBR elastomeric seals as standard. For more details on other seal materials see page J73–J74.

Part numbers shown are part of our current manufacturing programme.

Imperial and metric parts may vary in hexagon dimensions.

$$\frac{\text{PN (bar)}}{10} = \text{PN (MPa)}$$

Pressure ratings – PN shown, apply to Steel and Stainless Steel versions of the product.

XHMLO Conversion union

Triple-Lok® 37° flare tube end/O-Lok® ORFS tube end

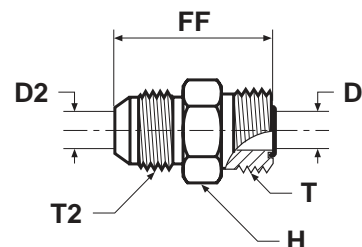

mm	Tube O.D.		Thread UN/UNF-2A T	Thread UN/UNF-2A T6	D mm	D2 mm	FF mm	H mm	Weight (steel) g/1 piece	O-Lok®		PN (bar)
	in.									Steel	Stainless Steel	
6	1/4		9/16-18	7/16-20	5	5	32	16	29	4 XHLO-S	4XHMLLOSS	500
8, 10	5/16, 3/8		11/16-16	9/16-18	7	7	34	19	45	6 XHLO-S	6XHMLLOSS	420
12	1/2		13/16-16	3/4-16	10	10	39	22	70	8 XHLO-S	8XHMLLOSS	420
14, 15, 16	5/8		1-14	7/8-14	13	13	47	27	119	10 XHLO-S	10XHMLLOSS	350
18, 20	3/4		1 3/16-12	1 1/16-12	16	16	52	32	181	12 XHLO-S	12XHMLLOSS	350
22, 25	1		1 7/16-12	1 5/16-12	21	21	55	38	265	16 XHLO-S	16XHMLLOSS	280
28, 30, 32	1 1/4		1 11/16-12	1 5/8-12	26	26	58	45	383	20 XHLO-S	20XHMLLOSS	280
35, 38	1 1/2		2-12	1 7/8-12	32	32	63	54	562	24 XHLO-S	24XHMLLOSS	210

O-Lok® is delivered with NBR elastomeric seals as standard. For more details on other seal materials see page J73–J74.

Part numbers shown are part of our current manufacturing programme.

Imperial and metric parts may vary in hexagon dimensions.

$$\frac{\text{PN (bar)}}{10} = \text{PN (MPa)}$$

Pressure ratings – PN shown, apply to Steel and Stainless Steel versions of the product.

J

XHML6 Conversion swivel nut connector

Triple-Lok® 37° flare tube end/O-Lok® ORFS female swivel end

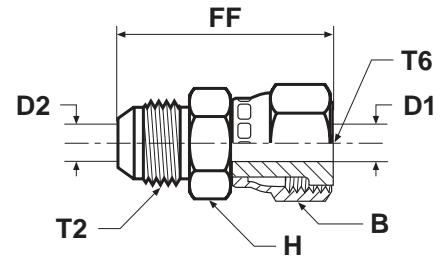

Tube O.D.		Thread UN/UNF-2A T2	Thread UN/UNF-2B T6	B	D1	D2	FF	H	Weight (steel)	O-Lok® Steel	O-Lok® Stainless Steel	PN (bar)
mm	in.			mm	mm	mm	mm	mm	g/1 piece			
6	1/4	7/16-20	9/16-18	17	4	4	38	16	29	4 XHL6-S	4XHML6SS	500
8, 10	5/16, 3/8	9/16-18	11/16-16	21	7	7	41	19	46	6 XHL6-S	6XHML6SS	420
12	1/2	3/4-16	13/16-16	24	9	9	48	22	73	8 XHL6-S	8XHML6SS	420
14, 15, 16	5/8	7/8-14	1-14	29	12	12	56	27	126	10 XHL6-S	10XHML6SS	350
18, 20	3/4	1 1/16-12	1 3/16-12	35	14	14	64	32	205	12 XHL6-S	12XHML6SS	350
22, 25	1	1 5/16-12	1 7/16-12	41	20	20	68	38	285	16 XHL6-S	16XHML6SS	280
28, 30, 32	1 1/4	1 5/8-12	1 11/16-12	48	26	26	71	43	623	20 XHL6-S	20XHML6SS	280

Part numbers shown are part of our current manufacturing programme.

Imperial and metric parts may vary in hexagon dimensions.

$$\frac{\text{PN (bar)}}{10} = \text{PN (MPa)}$$

Pressure ratings – PN shown, apply to Steel and Stainless Steel versions of the product.

LOHMX6 Conversion swivel nut connector

Triple-Lok® 37 flare female swivel end/O-Lok® ORFS male end

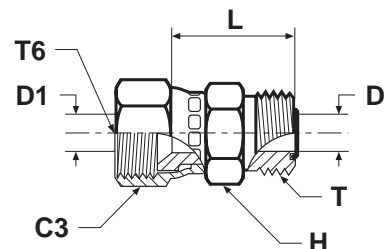

Tube O.D.		Thread UN/UNF-2A T	Thread UN/UNF-2B T6	C3	D	D1	H	L	Weight (steel) g/1 piece	O-Lok® Steel	O-Lok® Stainless Steel	PN (bar)
mm	in.			mm	mm	mm	mm	mm				
6	1/4	9/16-18	7/16-20	14	5	5	16	26	26	4 LOHX6-S	4LOHMX6SS	500
8, 10	5/16, 3/8	11/16-16	9/16-18	18	7	7	19	29	40	6 LOHX6-S	6LOHMX6SS	350
12	1/2	13/16-16	3/4-16	22	10	10	22	34	63	8 LOHX6-S	8LOHMX6SS	350
14, 15, 16	5/8	1-14	7/8-14	25	13	13	27	39	103	10 LOHX6-S	10LOHMX6SS	350
18, 20	3/4	1 3/16-12	1 1/16-12	32	16	16	32	41	162	12 LOHX6-S	12LOHMX6SS	350
22, 25	1	1 7/16-12	1 5/16-12	38	21	21	38	46	229	16 LOHX6-S	16LOHMX6SS	250

O-Lok® is delivered with NBR elastomeric seals as standard. For more details on other seal materials see page J73–J74.

Part numbers shown are part of our current manufacturing programme.

Imperial and metric parts may vary in hexagon dimensions.

$$\frac{\text{PN (bar)}}{10} = \text{PN (MPa)}$$

Pressure ratings – PN shown, apply to Steel and Stainless Steel versions of the product.



LOHU86 EO swivel adapter

O-Lok® ORFS tube end/EO 24° DKO swivel

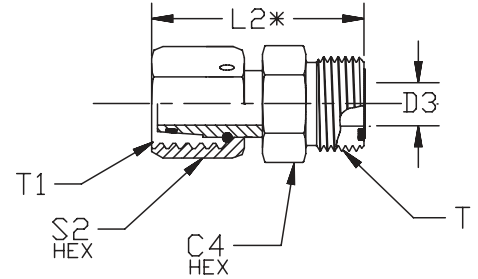

Tube O.D.		EO Swivel Size	Thread UN/UNF-2A T	Thread metric T1	C4 mm	D3 mm	L2 mm	S2 mm	Weight (steel) g/1 piece	O-Lok® Steel	PN (bar)
mm	in.										
6	1/4	6L	9/16-18	12 1.5	17	3	34	14	30	4-6L LOHU86-S	500
6	1/4	8L	9/16-18	14 1.5	17	4	34	17	50	4-8L LOHU86-S	500
10	3/8	10L	11/16-16	16 1.5	19	6	37	19	75	6-10L LOHU86-S	500
12	1/2	12L	13/16-16	18 1.5	22	8	39	22	145	8-12L LOHU86-S	400
16	5/8	15L	1-14	22 1.5	27	10	46	27	180	10-15L LOHU86-S	400
20	3/4	18L	1 3/16-12	26 1.5	32	13	48	32	250	12-18L LOHU86-S	400
25	1	22L	1 7/16-12	30 2	41	17	53	36	305	16-22L LOHU86-S	250
6	1/4	6S	9/16-18	14 1.5	17	3	34	17	30	4-6S LOHU86-S	630
6	1/4	8S	9/16-18	16 1.5	17	4	34	19	50	4-8S LOHU86-S	630
10	3/8	10S	11/16-16	18 1.5	19	5	37	22	75	6-10S LOHU86-S	630
12	1/2	12S	13/16-16	20 1.5	22	8	40	24	145	8-12S LOHU86-S	630
16	5/8	14S	1-14	22 1.5	27	9	47	27	180	10-14S LOHU86-S	420
16	5/8	16S	1-14	24 1.5	27	11	47	30	185	10-16S LOHU86-S	420
20	3/4	20S	1 3/16-12	30 2	32	14	52	36	260	12-20S LOHU86-S	420
25	1	25S	1 7/16-12	36 2	41	18	55	46	308	16-25S LOHU86-S	420

O-Lok® is delivered with NBR elastomeric seals as standard. For more details on other seal materials see page J73–J74.

Part numbers shown are part of our current manufacturing programme.

Imperial and metric parts may vary in hexagon dimensions.

$$\frac{\text{PN (bar)}}{10} = \text{PN (MPa)}$$

FNLBA Bleed adaptor

O-Lok® ORFS female end

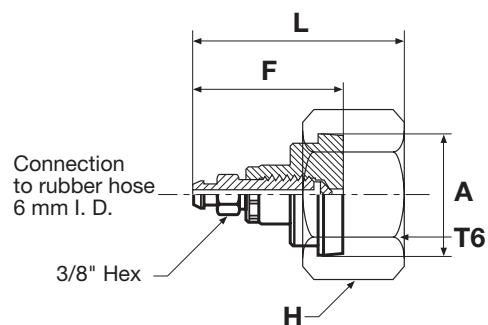

Thread UN/UNF-2B T6	A (mm)	F (mm)	H (mm)	L (mm)	Weight (steel) g/1 piece	O-Lok® Steel	O-Lok® Stainless Steel	PN (bar)
13/16-16	19	41	24	53	49	8 FNLBA-S	8 FNLBA-SS	420
1-14	23	41	30	55	77	10 FNLBA-S	10 FNLBA-SS	420
1 3/16-12	27	41	36	56	111	12 FNLBA-S	12 FNLBA-SS	420
1 7/16-12	33	41	41	56	113	16 FNLBA-S	16 FNLBA-SS	420
1 11/16-12	40	41	50	56	151	20 FNLBA-S	20 FNLBA-SS	280
2-12	48	41	60	56	161	24 FNLBA-S	24 FNLBA-SS	280

Part numbers shown are part of our current manufacturing programme.

Imperial and metric parts may vary in hexagon dimensions.

$$\frac{\text{PN (bar)}}{10} = \text{PN (MPa)}$$

Pressure ratings – PN shown, apply to Steel and Stainless Steel versions of the product.



PNLOBA Bleed adaptor

O-Lok® ORFS female end

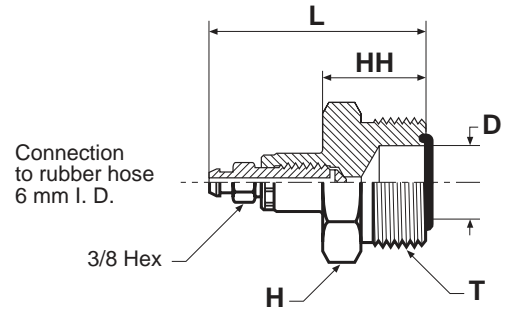

Tube O.D.		Thread UN/UNF-2A T	D mm	H mm	HH mm	L mm	Weight (steel) g/1 piece	O-Lok® Steel	PN (bar)
mm	in.								
6	1/4	9/16-18	5	17	20	48	57	4 PNLOBA-S	420
8, 10	5/16, 3/8	11/16-16	7	19	22	50	64	6 PNLOBA-S	420
12	1/2	13/16-16	10	22	23	53	93	8 PNLOBA-S	420
14, 15, 16	5/8	1-14	13	27	26	56	127	10 PNLOBA-S	420
18, 20	3/4	1.3/16-12	16	32	27	58	220	12 PNLOBA-S	420
22, 25	1	1.7/16-12	21	38	28	60	266	16 PNLOBA-S	420
28, 30, 32	1 1/4	1.11/16-12	26	45	28	61	304	20 PNLOBA-S	280
35, 38	1 1/2	2-12	32	54	28	63	422	24 PNLOBA-S	280

O-Lok® is delivered with NBR elastomeric seals as standard. For more details on other seal materials see page J73–J74.

Part numbers shown are part of our current manufacturing programme.

Imperial and metric parts may vary in hexagon dimensions.

$$\frac{\text{PN (bar)}}{10} = \text{PN (MPa)}$$

HPBA Bleed adaptor

Bleed hose connection/Male NPTF thread (SAE J476)

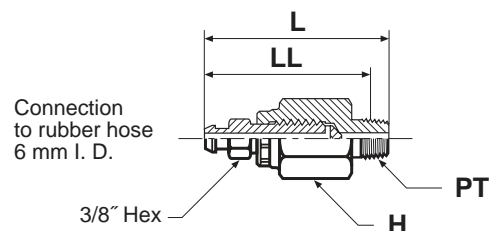

Thread NPTF PT	H mm	L mm	LL mm	O-Lok® Steel	PN (bar)
1/4-18	18	56	47	1/4 HPBA-S	420

Imperial and metric parts may vary in hexagon dimensions.

$$\frac{\text{PN (bar)}}{10} = \text{PN (MPa)}$$



P5ONBA Bleed adaptor

Bleed hose connection/Male UN/UNF thread – O-ring (ISO 11926)

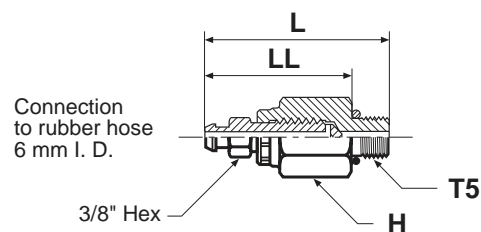

Thread UN/UNF-2A T5	H mm	L mm	LL mm	O-Lok® Steel	PN (bar)
7/16-20	18	52	41	4 P5ONBA-S	420

O-Lok® is delivered with NBR elastomeric seals as standard. For more details on other seal materials see page J73–J74.

Part numbers shown are part of our current manufacturing programme.

Imperial and metric parts may vary in hexagon dimensions.

$$\frac{\text{PN (bar)}}{10} = \text{PN (MPa)}$$

TW3L Weld nipple

O-Lok® ORFS female end/Butt weld end

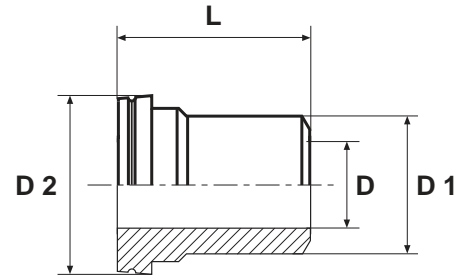

Tube O.D. mm	D mm	D1 mm	D2 mm	L mm	Weight (steel) g/1 piece	O-Lok® Steel	O-Lok® Stainless Steel
6	2	6	13	25	10	TW3LS6	TW3LSS6
8	3	8	13	25	12	TW3LS8	TW3LSS8
10	4	10	16	26	15	TW3LS10	TW3LSS10
12	5	12	19	26	18	TW3LS12	TW3LSS12
16	10	16	23	32	25	TW3LS16	TW3LSS16
20	13	20	28	37	30	TW3LS20	TW3LSS20
25	16	25	34	42	37	TW3LS25	TW3LSS25
30	22	30	41	44	43	TW3LS30	TW3LSS30
38	28	38	48	49	70	TW3LS38	TW3LSS38

Part numbers shown are part of our current manufacturing programme.

WLNML Bulkhead locknut

SAE 520118/SAE 52M0118 ISO 8434-3 BHLN

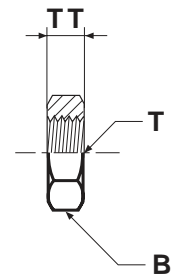

Thread UN/UNF-2B T	B mm	TT mm	Weight (steel) g/1 piece	O-Lok® Steel	O-Lok® Stainless Steel
9/16-18	22	7	11	4WLNMLS	4WLNMLSS
11/16-16	27	8	23	6WLNMLS	6WLNMLSS
13/16-16	30	9	26	8WLNMLS	8WLNMLSS
1-14	32	11	38	10WLNMLS	10WLNMLSS
1 3/16-12	38	11	44	12WLNMLS	12WLNMLSS
1 7/16-12	46	11	54	16WLNMLS	16WLNMLSS
1 11/16-12	51	10	73	20 WLNML-S	20WLNMLSS
2-12	60	10	102	24 WLNML-S	24WLNMLSS

Part numbers shown are part of our current manufacturing programme.

Imperial and metric parts may vary in hexagon dimensions.

Spare parts guide – O-Lok® retaining rings and seals

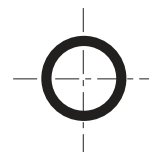

Face seal end O-rings SAE J1453/ISO 8434-3

Dash size	Thread UN/UNF	O-ring order code		O-ring ID section mm	
		NBR	FKM		
4	9/16-18	2-011-N552-9	2-011-V894-9	7.65	1.78
6	11/16-16	2-012-N552-9	2-012-V894-9	9.25	1.78
8	13/16-16	2-014-N552-9	2-014-V894-9	12.42	1.78
10	1-14	2-016-N552-9	2-016-V894-9	15.60	1.78
12	1 3/16-12	2-018-N552-9	2-018-V894-9	18.77	1.78
16	1 7/16-12	2-021-N552-9	2-021-V894-9	23.52	1.78
20	1 11/16-12	2-025-N552-9	2-025-V894-9	29.87	1.78
24	2-12	2-029-N552-9	2-029-V894-9	37.82	1.78
32	2 1/2-12	2-135-N552-9	2-135-V894-9	48.90	2.62

BSPP male threads – ISO 1179

Thread BSPP	ED seal order code		O-ring order code*		O-ring ID section mm	Retainer ring Order code Steel	Retainer ring Order code Stainless Steel
	NBR	FKM	NBR	FKM			
1/8	ED10X1X	ED10X1VITX	6-002-N552-9	6-002-V894-9	8.00 2.00	8207-1/8	8207SS1/8
1/4	ED14X1.5X	ED14X1.5VITX	2-111-N552-9	2-111-V894-9	10.77 2.62	8207-1/4	8207SS1/4A
3/8	ED3/8X	ED3/8VITX	2-113-N552-9	2-113-V894-9	13.94 2.62	8207-3/8	8207SS3/8A
1/2	ED1/2X	ED1/2VITX	5-256-N552-9	5-256-V894-9	17.96 2.62	8207-1/2	8207SS1/2
3/4	ED26X1.5X	ED26X1.5VITX	2-119-N552-9	2-119-V894-9	23.47 2.62	8207-3/4	8207SS3/4
1	ED33X2X	ED33X2VITX	2-217-N552-9	2-217-V894-9	29.74 3.53	8207-1	8207SS1A
1 1/4	ED42X2X	ED42X2VITX	2-222-N552-9	2-222-V894-9	37.69 3.53	8207-1-1/4	8207SS1 1/4
1 1/2	ED48X2X	ED48X2VITX	2-224-N552-9	2-224-V894-9	44.04 3.53	8207-1-1/2	8207SS1 1/2

Typical fittings using these parts: F42EDMLO/C4OMLO/V4OMLO etc.

*Must be used with correct retainer ring.

Metric male threads – ISO 9974

Thread metric	ED seal order code		O-ring order code*		O-ring ID section mm	Retainer ring Order code Steel	Retainer ring Order code Stainless Steel
	NBR	FKM	NBR	FKM			
M10 1	ED10X1/R1/8	ED10X1R1/8VIT	6-074-N552-9	6-074-V894-9	8.00 1.50	M10RR	RRM10X1SS
M12 1.5	ED12X1.5	ED14X1.5/VIT	2-012-N552-9	2-012-V894-9	9.25 1.78	M12RR	RRM12X1.5SS
M14 1.5	ED14X1.5/R1/4	ED14X1.5/R1/4VIT	2-013-N552-9	2-013-V894-9	10.82 1.78	M14RR	RRM14X1.5SS
M16 1.5	ED16X1.5	ED16X1.5/VIT	3-907-N552-9	3-907-V894-9	13.46 2.08	M16RR	RRM16X1.5SS
M18 1.5	ED18X1.5	ED18X1.5/VIT	2-114-N552-9	2-114-V894-9	15.54 2.62	M18RR	RRM18X1.5SS
M22 2	ED22X1.5	ED22X1.5VIT	2-018-N552-9	2-018-V894-9	18.77 1.78	M22RR	RRM22X1.5SS
M27 2	ED26X1.5X**	ED26X1.5VITX	2-119-N552-9	2-119-V894-9	23.47 2.62	M27RR	RRM27X2SS
M33 2	ED33X2R1	ED33X2/R1VIT	2-122-N552-9	2-122-V894-9	28.24 2.62	M33RR	RRM33X2SS
M42 2	ED42X2/R1.1/4	ED42X2R1.1/4VIT	2-128-N552-9	2-128-V894-9	37.77 2.62	M42RR	RRM42X2SS
M48 2	ED48X2/R1.1/2	ED48X2R1.1/2VIT	2-132-N552-9	2-132-V894-9	44.12 2.62	M48RR	RRM48X2SS

Typical fittings using these parts: F82EDMLO/C8OMLO/V8OMLO etc.

*Must be used with correct retainer ring.

**Same seal used for M26 1.5 and M27 2

Spare parts guide – O-Lok® retaining rings and seals

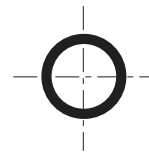

UN/UNF male threads – ISO 11926

Dash size	Thread UN/UNF	O-ring order code		O-ring ID section mm	
		NBR	FKM		
2	5/16-24	3-902-N552-9	3-902-V894-9	6.07	1.63
3	3/8-24	3-903-N552-9	3-903-V894-9	7.65	1.63
4	7/16-20	3-904-N552-9	3-904-V894-9	8.92	1.83
5	1/2-20	3-905-N552-9	3-905-V894-9	10.52	1.83
6	9/16-18	3-906-N552-9	3-906-V894-9	11.89	1.98
8	3/4-16	3-908-N552-9	3-908-V894-9	16.36	2.21
10	7/8-14	3-910-N552-9	3-910-V894-9	19.18	2.46
12	1 1/16-12	3-912-N552-9	3-912-V894-9	23.47	2.95
14	1 3/16-12	3-914-N552-9	3-914-V894-9	26.59	2.95
16	1 5/16-12	3-916-N552-9	3-916-V894-9	29.74	2.95
20	1 5/8-12	3-920-N552-9	3-920-V894-9	37.47	3.00
24	1 7/8-12	3-924-N552-9	3-924-V894-9	43.69	3.00
32	2 1/2-12	3-932-N552-9	3-932-V894-9	59.36	3.00

Typical fittings using these parts: F5OMLO/C5OMLO/R5OMLO etc.

Metric male threads – ISO 6149

Thread metric	O-ring order code		O-ring ID section (mm)	
	NBR	FKM		
M10 1	6-345-N552-9	6-345-V894-9	8.20	1.50
M12 1.5	6-346-N552-9	6-346-V894-9	9.40	2.10
M14 1.5	6-347-N552-9	6-347-V894-9	11.40	2.10
M16 1.5	6-348-N552-9	6-348-V894-9	13.40	2.10
M18 1.5	6-349-N552-9	6-349-V894-9	15.40	2.10
M22 1.5	6-350-N552-9	6-350-V894-9	19.40	2.10
M27 2	6-351-N552-9	6-351-V894-9	23.70	2.80
M33 2	6-352-N552-9	6-352-V894-9	29.70	2.80
M42 2	6-353-N552-9	6-353-V894-9	38.70	2.80
M48 2	6-354-N552-9	6-354-V894-9	46.70	2.80

Typical fittings using these parts: F87OMLO/S87OMLO etc.

Other seal compounds available on request for alternative applications.

SBR Braze ring

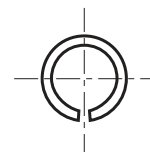

For metric tubing

Tube O.D. mm	Order code
6	SBR6
8	SBR8
10	SBR10
12	SBR12
14	SBR14
15	SBR15
16	SBR16
18	SBR18
20	SBR20
22	SBR22
25	SBR25
28	SBR28
30	SBR30
32	SBR32
35	SBR35
38	SBR38
50	SBR50

For inch tubing

Tube O.D. in.	Order code
1/4	4SBR
3/8	6SBR
1/2	8SBR
5/8	10SBR
3/4	12SBR
1	16SBR
1 1/4	20SBR
1 1/2	24SBR
2	32SBR

Part numbers shown are part of our current manufacturing programme.

J

Flange-Seal components

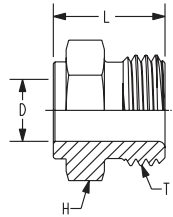

Flange-Seal fitting
LHP

Tube O.D. mm	Thread T UN/UNF-2A	H mm	L mm	Weight (steel) g/1 St.	Order code
1/4	9/16-18	16	15.0	15	4 LHP-S
3/8	11/16-16	19	17.5	22	6 LHP-S
1/2	13/16-16	22	20.0	33	8 LHP-S
5/8	1-14	27	24.0	59	10 LHP-S
3/4	1 3/16-12	32	25.5	85	12 LHP-S

Tube O.D. mm	Thread T UN/UNF-2A	H mm	L mm	Weight (steel) g/1 St.	Order code
6	9/16-18	17	15.0	15	LHMPS6
8	11/16-16	17	17.5	25	LHMPS8
10	11/16-16	19	17.5	22	LHMPS10
12	13/16-16	22	20.0	33	LHMPS12
16	1-14	27	24.0	59	LHMPS16
20	1 3/16-12	32	25.5	85	LHMPS20

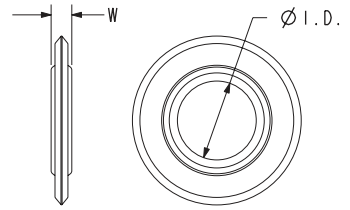

Bonded Seal element
PLS

Fitting dash size	Tube O.D. mm	Tube O.D. inch	I.D. mm	W mm	Weight (steel) g/1 St.	Seal Order code
4	6	1/4	6	2	1	4 PL-S N0702
6	8, 10	3/8	9	2	1	4 PL-S N0702
8	12	1/2	12	2	1	4 PL-S N0702
10	16	5/8	16	2	2	4 PL-S N0702
12	20	3/4	20	2	2	4 PL-S N0702

Pressure ratings and tube limitations

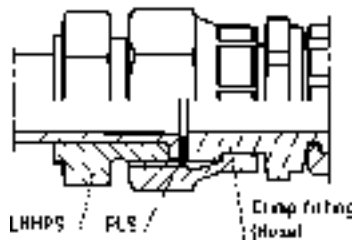

Tube to hose

Order code	Dash size	Tube O.D. mm	max. wall thickness tube to hose	PN
LHMPS6	4	6	1.5	420
LHMPS8	6	8	2.0	420
LHMPS10	6	10	2.0	420
LHMPS12	8	12	2.5	420
LHMPS16	10	16	3.0	420
LHMPS20	12	20	3.5	420

Tube to hose

Order code	Dash size	Tube O.D. inch	max. wall thickness tube to hose	PN
4 LHP-S	4	1/4	0.065	420
6 LHP-S	6	3/8	0.095	420
9 LHP-S	8	1/2	0.095	420
10 LHP-S	10	5/8	0.120	420
12 LHP-S	12	3/4	0.134	420

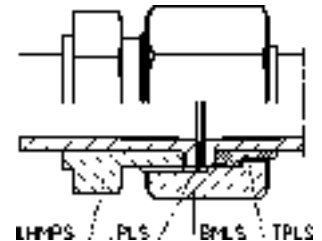

Tube to tube

Order code	Dash size	Tube O.D. mm	max. wall thckn. Tube to tube	Example PN for St 37 NBK*
LHMPS6	4	6	1.0	370
LHMPS8	6	8	1.5	410
LHMPS10	6	10	1.5	360
LHMPS12	8	12	2.0	390
LHMPS16	10	16	2.0	300
LHMPS20	12	20	2.5	300

Tube to tube

Order code	Dash size	Tube O.D. inch	max. wall thckn. Tube to tube	Example PN for St 37 NBK*
4 LHP-S	4	1/4	0.049	400
6 LHP-S	6	3/8	0.065	345
8 LHP-S	8	1/2	0.095	385
10 LHP-S	10	5/8	0.120	385
12 LHP-S	12	3/4	0.120	320

*For higher strength tube, connection PN may be increased to maximum shown in Tube to hose table 420 bar.

*For higher strength tube, connection PN may be increased to maximum shown in Tube to hose table 420 bar.











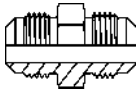
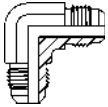
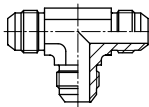
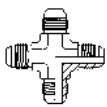
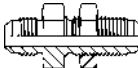
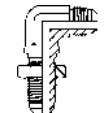
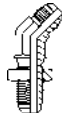
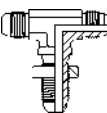
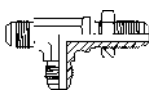

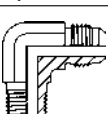
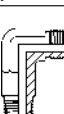
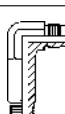
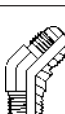
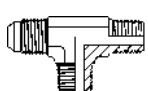
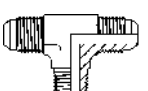

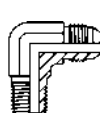

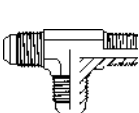
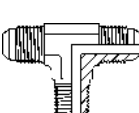

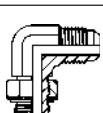

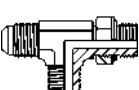
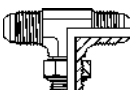



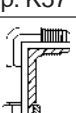
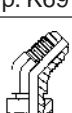
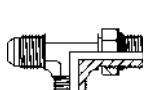
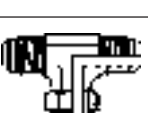

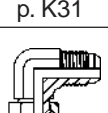
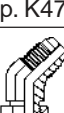
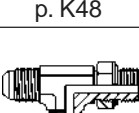
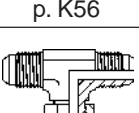

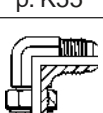
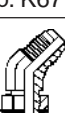
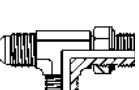
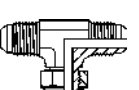

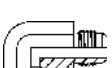





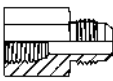
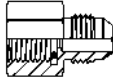

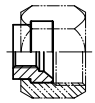
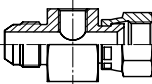
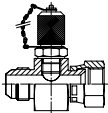
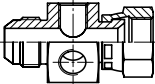
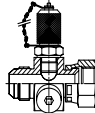

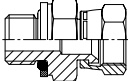
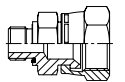

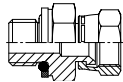
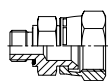
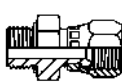
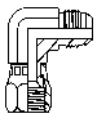
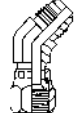
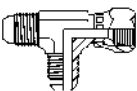

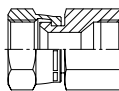
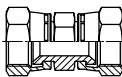
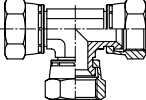
Triple-Lok[®]

*The universal
37° flared fitting*

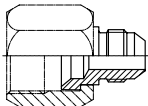
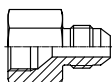

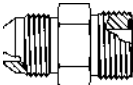
Visual index

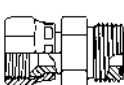
Tube to tube	 HMTX p. K9	 EMTX p. K10	 JMTX p. K11	 KTX p. K14			
Bulkhead union	 WMTX p. K15	 WEMTX p. K16	 WNTX p. K17	 WJTX p. K18	 WJJTX p. K19	 WLNM p. K92	
Tube to male NPTF	 FMTX p. K36	 CMTX p. K51	 CCTX p. K52	 CCCTX p. K53	 VMTX p. K59	 RMTX p. K71	 SMTX p. K65
Tube to male BSPT	 F3MX p. K37	 C3MX p. K54	 V3MX p. K60	 R3MX p. K72	 S3MX p. K66		
Tube to male BSPP	 F4OMX p. K33	 F42EDMX p. K32	 C4OMX p. K49	 V4OMX p. K57	 R4OMX p. K69	 S4OMX p. K63	
Tube to straight thread UNF	 F5OMX p. K29	 FF5OMX p. K31	 C5OMX p. K47	 CC5OX p. K48	 V5OMX p. K56	 R5OMX p. K68	 S5OMX p. K62
Tube to male metric ISO 6149-3	 F87OMX p. K28	 C87OMX p. K46	 V87OMX p. K55	 R87OMX p. K67	 S87OMX p. K61		
Tube to male metric DIN 3852-1	 F8OMX p. K35	 F82EDMX p. K34	 C8OMX p. K50	 V8OMX p. K58	 R8OMX p. K70	 S8OMX p. K64	
Tube to female NPTF	 GMTX p. K74	 WGMTX p. K75	 DMTX p. K76	 OTX p. K77	 MTX p. K78	 G6X p. K79	

Pressure gauge connectors	 <p>G4MX p. K73</p>	 <p>G4MXMO p. K80</p>	 <p>TT4MX p. K81</p>	 <p>TTP4MX p. K82</p>			
	 <p>R604MX p. K83</p>	 <p>R6P4MX p. K84</p>	 <p>K6004MX p. K85</p>	 <p>K6PP4MX p. K86</p>			
Triple-Lok® swivel nut male pipe	 <p>F6MX p. K44</p>	 <p>F63MX p. K45</p>					
Triple-Lok® swivel nut straight thread	 <p>F640MX p. K41</p>	 <p>F642EDMX p. K40</p>	 <p>F650MX p. K39</p>	 <p>F680MX p. K43</p>	 <p>F682EDMX p. K42</p>	 <p>F687OMX p. K38</p>	
Tube to Triple-Lok swivel nut	 <p>C6MX p. K20</p>	 <p>V6MX p. K21</p>	 <p>R6MX p. K23</p>	 <p>S6MX p. K22</p>	 <p>BBMTX p. K24</p>	 <p>HMX6 p. K26</p>	 <p>JX6 p. K27</p>
Nuts & Sleeves	 <p>BMTX p. K6</p>	 <p>BTX p. K5</p>	 <p>TX p. K7</p>				
Tube end reducers Plug Caps	 <p>TRMTX p. K25</p>	 <p>FNMTX p. K87</p>	 <p>PNMTX p. K88</p>				
Adapters Triple-Lok®/ O-Lok®	 <p>XHML0 p. K89</p>	 <p>XHML6 p. K90</p>	 <p>LOHMX6 p. K91</p>				
Seals Retaining ring and Tooling	 <p>Triple-Lok® Components p. K93</p>						



How to order Triple-Lok® fittings

Example Order code **6-8 C 5 O M X S**

1 2 3 4 5 6 7

1 Order codes for tube and port thread ends

Dash Size	Tube Size (Inch)	Tube Size (mm)	Port Thread Size (Inch) BSPP/BSPT/NPT	Port Thread Size UN / UNF
2	1/8		1/8	5/16-24
3	3/16			3/8-24
4	1/4	6	1/4	7/16-20
5				1/2-20
6	3/8	8,10	3/8	9/16-18
8	1/2	12	1/2	3/4-16
10	5/8	14,15,16	5/8	7/8-14
12	3/4	18,20	3/4	1 1/6-12
14				1 3/6-12
16	1	25	1	1 5/6-12
20	1 1/4	28,30,32	1 1/4	1 5/8-12
24	1 1/2	35,38	1 1/2	1 7/8-12
28		42		2 1/4-12
32	2	50	2	2 1/2-12

Metric port threads are shown as per example 4M12C87OMXS

3 Threads and sealing methods

Code	Description
None	NPT/NPTF Thread
3	BSPT Thread
4	BSPP Thread O-Ring & Retainer Ring
42	BSPP Thread EOLASTIC seal 'ED'
5	UN/UNF Thread (O-Ring Seal)
8	Metric Thread O-Ring & Retainer Ring
82	Metric Thread EOLASTIC seal 'ED'
87	Metric ISO 6149 Thread (O-Ring Seal)
63	Swivel Connector BSPT end
64	Swivel Connector BSPP end (O-Ring & Retainer Ring)
642	Swivel Connector BSPP end (EOLASTIC Seal 'ED')
65	Swivel Connector UN/UNF end (O-Ring seal)
68	Swivel Connector Metric end (O-Ring & Retainer Ring)
682	Swivel Connector Metric end (EOLASTIC Seal 'ED')
687	Swivel Connector Metric ISO 6149 end

2 Codes for fitting styles/shapes

Code	Description
AE6	Straight Thread Swivel
B	Nut
C	Male Stud elbow
CC	Long Male Stud elbow
CCC	Extra Long Male Stud elbow
C6	Swivel Nut Elbow
D	Female Elbow
E	Union elbow
F	Male Stud connector
FF	Long Male Stud connector
F6	Male Stud Swivel
FN	Cap
G	Female Connector
G-MO	Gauge Adapter Fitting
G6	Female Connector Swivel
H	Straight union
H6	Swivel/Swivel Adapter
J	Union Tee
J6	Swivel Tee
K	Union Cross
LOHX6	Triple-Lok® Swivel/O-Lok® Adapter
M	Female Run Tee
O	Female Branch Tee
PN	Plug
R	Male Stud Run Tee
R6	Swivel Run Tee
S	Male Stud Branch Tee
S6	Swivel Branch Tee
T	Sleeve
TR	Tube End Reducer
TT	Test Point Adapter
V	45° male stud elbow
V6	Swivel Nut 45° Elbow
W	Bulkhead Union
WE	Bulkhead Union Elbow
WG	Female Bulkhead connector
WJJ	Bulkhead Run Tee
WJT	Bulkhead Branch Tee
WLN	Bulkhead Locknut
WN	Bulkhead 45° union elbow
XHL	Triple Lok® / O-Lok® Adaptor
XHL6	Triple Lok® / O-Lok® Swivel Adaptor

4 Stud connector seal

Code	Description
O	O-Ring Seal (Assembled on fitting)
ED	Captive EOLASTIC Seal (Assembled on fitting)
No Code	No Seal (O-Ring not assembled on fitting)

5 Hexagon/ Across flats style

Code	Description
M	Metric Hexagon Dimension
No Code	Inch Hexagon Dimension

6 Fitting type

Code	Description
X	Parker Triple-Lok®

7 Fitting material

Code	Description
S	Steel
SS	Stainless Steel
B	Brass

BTX Nut

Triple-Lok® 37° Flare end nut
SAE 070110 MS51531

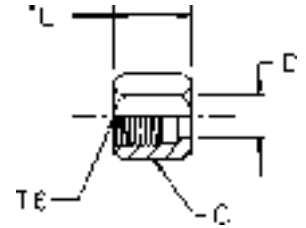

mm	Tube	Thread UN/UNF-2B T6	C in.	D mm	L mm	Weight (steel) g/1 piece	Triple-Lok® Steel	Triple-Lok® Stainless Steel	Triple-Lok® Brass
	O.D. in.								
6	1/8	5/16-24	3/8	5	14	6	2 BTX-S	2 BTX-SS	2 BTX-B
	3/16	3/8-24	7/16	6	16	8	3 BTX-S	3 BTX-SS	3 BTX-B
	1/4	7/16-20	9/16	8	16	11	4 BTX-S	4 BTX-SS	4 BTX-B
	5/16	1/2-20	5/8	10	17	14	5 BTX-S	5 BTX-SS	5 BTX-B
	3/8	9/16-18	11/16	11	18	18	6 BTX-S	6 BTX-SS	6 BTX-B
14, 15, 16	1/2	3/4-16	7/8	15	22	29	8 BTX-S	8 BTX-SS	8 BTX-B
	5/8	7/8-14	1	18	25	54	10 BTX-S	10 BTX-SS	10 BTX-B
	3/4	1 1/16-12	1 1/4	21	26	73	12 BTX-S	12 BTX-SS	12 BTX-B
	7/8	1 3/16-12	1 3/8	24	28	100	14 BTX-S	14 BTX-SS	14 BTX-B
	1	1 5/16-12	1 1/2	28	29	104	16 BTX-S	16 BTX-SS	16 BTX-B
28, 30, 32	1 1/4	1 5/8-12	2	34	31	240	20 BTX-S	20 BTX-SS	20 BTX-B
	1 1/2	1 7/8-12	2 1/4	41	36	325	24 BTX-S	24 BTX-SS	24 BTX-B
	2	2 1/2-12	2 7/8	55	45	549	32 BTX-S	32 BTX-SS	32 BTX-B

Order codes shown are part of our current manufacturing programme.

K

BMTX Nut

Triple-Lok® 37° Flare end nut
SAE 070110

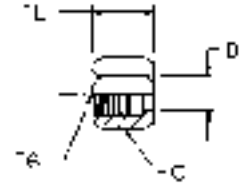

Tube O.D.		Thread UN/UNF-2B T6	C mm	D mm	L mm	Weight (steel) g/1 piece	Triple-Lok® Steel	Triple-Lok® Stainless Steel
mm	in.							
6	1/4	7/16-20	14	8	16	11	4BMTXS	4BMTXSS
8	5/16	1/2-20	17	10	17	14	5BMTXS	5BMTXSS
10	3/8	9/16-18	19	11	18	18	6BMTXS	6BMTXSS
12	1/2	3/4-16	22	15	21	29	8BMTXS	8BMTXSS
14, 15, 16	5/8	7/8-14	27	18	25	42	10BMTXS	10BMTXSS
18, 20	3/4	1 1/16-12	32	22	26	73	12BMTXS	12BMTXSS
25	1	1 5/16-12	41	28	28	104	16BMTXS	16BMTXSS
28, 30, 32	1 1/4	1 5/8-12	50	34	31	240	20BMTXS	20BMTXSS
35, 38	1 1/2	1 7/8-12	60	41	36	325	24BMTXS	24BMTXSS
42		2 1/4	65	48	40	437	28BMTXS	28BMTXSS

Order codes shown are part of our current manufacturing programme.

TX Sleeve

Triple-Lok® 37° Flare tube end sleeve for metric tubes
SAE 070105

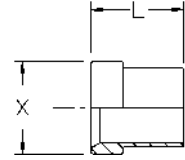

Tube O.D. mm	L mm	X mm	Weight (steel) g/1 piece	Triple-Lok® Steel	Triple-Lok® Stainless Steel	Triple-Lok® Brass
6	10	10	2	TXS6	TXSS6	TXB6
8	11	11	2	TXS8	TXSS8	TXB8
10	13	13	2	TXS10	TXSS10	TXB10
12	14	17	7	TXS12	TXSS12	TXB12
14	17	20	13	TXS14	TXSS14	TXB14
15	17	20	10	TXS15	TXSS15	TXB15
16	17	20	7	TXS16	TXSS16	TXB16
18	17	25	16	TXS18	TXSS18	TXB18
20	17	25	12	TXS20	TXSS20	TXB20
22	19	28	25	TXS22	TXSS22	TXB22
25	20	31	21	TXS25	TXSS25	TXB25
28	23	39	40	TXS28	TXSS28	TXB28
30	23	39	45	TXS30	TXSS30	TXB30
32	23	39	30	TXS32	TXSS32	TXB32
35	28	45	60	TXS35	TXSS35	TXB35
38	28	45	51	TXS38	TXSS38	TXB38
42	29	55	149	TXS42	TXSS42	TXB42

Order codes shown are part of our current manufacturing programme.

K

TX Sleeve

Triple-Lok® 37° Flare tube sleeve
SAE 070105 MS51533

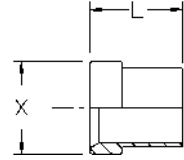

Tube O.D. in.	L mm	X mm	Weight (steel) g/1 piece	Triple-Lok® Steel	Triple-Lok® Stainless Steel	Triple-Lok® Brass
1/8	9	7	2	2 TX-S	2 TX-SS	2 TX-B
3/16	9	8	2	3 TX-S	3 TX-SS	3 TX-B
1/4	10	10	2	4 TX-S	4 TX-SS	4 TX-B
5/16	11	11	2	5 TX-S	5 TX-SS	5 TX-B
3/8	13	13	3	6 TX-S	6 TX-SS	6 TX-B
1/2	14	17	6	8 TX-S	8 TX-SS	8 TX-B
5/8	17	20	8	10 TX-S	10 TX-SS	10 TX-B
3/4	17	25	13	12 TX-S	12 TX-SS	12 TX-B
7/8	19	28	18	14 TX-S	14 TX-SS	14 TX-B
1	20	31	23	16 TX-S	16 TX-SS	16 TX-B
1 1/4	23	39	30	20 TX-S	20 TX-SS	20 TX-B
1 1/2	28	45	51	24 TX-S	24 TX-SS	24 TX-B
2	30	61	156	32 TX-S	32 TX-SS	32 TX-B

Order codes shown are part of our current manufacturing programme.

HMTX Union

Triple-Lok® 37° Flare ends
SAE 070101 MS51501

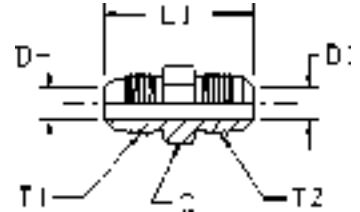

Tube 1 O.D.		Tube 2 O.D.		Thread UN/UNF-2A T1	Thread UN/UNF-2A T2	C	D	D1	L1	Weight (steel) g/1 piece	Triple-Lok® Steel	Triple-Lok® Stainless Steel	Triple-Lok® Brass	PN (bar)
mm	in.	mm	in.			mm	mm	mm	mm					
6	1/8	6	1/8	5/16-24	5/16-24	11	2	2	30	9	2 HTX-S			500
	3/16		3/16	3/8-24	3/8-24	11	3	3	31	10	3 HTX-S			500
	1/4		1/4	7/16-20	7/16-20	13	4	4	35	16	4HMTXS	4HMTXSS	4HMTXB	500
	1/4		1/8	7/16-20	5/16-24	13	5	2	32	12	4-2 HTX-S	4-2HMTXSS	4-2HMTXB	500
6	1/4		3/16	7/16-20	3/8-24	13	5	3	33	4-3 HTX-S	4-3HMTXSS	4-3HMTXB	500	
8	5/16	8	5/16	1/2-20	1/2-20	14	6	6	35	18	5HMTXS	5HMTXSS	5HMTXB	420
8	5/16	6	1/4	1/2-20	7/16-20	14	6	5	35	18	5-4 HTX-S	5-4HMTXSS	5-4HMTXB	420
10	3/8	10	3/8	9/16-18	9/16-18	17	8	8	36	25	6HMTXS	6HMTXSS	6HMTXB	420
10	3/8	6	1/4	9/16-18	7/16-20	17	8	4	36	22	6-4HMTXS	6-4HMTXSS	6-4HMTXB	420
10	3/8	8	5/16	9/16-18	1/2-20	17	8	6	36	25	6-5 HTX-S	6-5HMTXSS	6-5HMTXB	420
12	1/2	12	1/2	3/4-16	3/4-16	19	10	10	41	52	8HMTXS	8HMTXSS	8HMTXB	420
12	1/2	6	1/4	3/4-16	7/16-20	21	10	5	39	45	8-4 HTX-S	8-4HMTXSS	8-4HMTXB	420
12	1/2	10	3/8	3/4-16	9/16-18	19	10	8	39	45	8-6HMTXS	8-6HMTXSS	8-6HMTXB	420
14, 15, 16	5/8	14, 15, 16	5/8	7/8-14	7/8-14	24	12	12	48	80	10HMTXS	10HMTXSS	10HMTXB	350
14, 15, 16	5/8	10	3/8	7/8-14	9/16-18	24	13	8	43	60	10-6HMTXS	10-6HMTXSS	10-6HMTXB	350
14, 15, 16	5/8	12	1/2	7/8-14	3/4-16	24	12	10	45	68	10-8HMTXS	10-8HMTXSS	10-8HMTXB	350
18, 20	3/4	18, 20	3/4	1 1/16-12	1 1/16-12	27	16	16	55	125	12HMTXS	12HMTXSS	12HMTXB	350
18, 20	3/4	12	1/2	1 1/16-12	3/4-16	29	16	10	50	101	12-8 HTX-S	12-8HMTXSS	12-8HMTXB	350
20	3/4	14, 15, 16	5/8	1 1/16-12	7/8-14	29	16	12	52	113	12-10HMTXS	12-10HMTXSS	12-10HMTXB	350
22	7/8	22	7/8	1 3/16-12	1 3/16-12	32	18	18	56	156	14 HTX-S	14HMTXSS	14HMTXB	280
25	1	25	1	1 5/16-12	1 5/16-12	36	22	22	57	131	16HMTXS	16HMTXSS	16HMTXB	280
25	1	20	3/4	1 5/16-12	1 1/16-12	36	22	16	56	169	16-12HMTXS	16-12HMTXSS	16-12HMTXB	280
28, 30, 32	1 1/4	28, 30, 32	1 1/4	1 5/8-12	1 5/8-12	46	28	28	62	271	20HMTXS	20HMTXSS	20HMTXB	280
28, 30, 32	1 1/4	25	1	1 5/8-12	1 5/16-12	46	28	22	61	235	20-16HMTXS	20-16HMTXSS	20-16HMTXB	280
35, 38	1 1/2	35, 38	1 1/2	1 7/8-12	1 7/8-12	50	33	33	70	382	24HMTXS	24HMTXSS	24HMTXB	210
42		42		2 1/4-12	2 1/4-12	60	39	39	71	469	28HMTXS	28HMTXSS	28HMTXB	140
	2		2	2 1/2-12	2 1/2-12	67	45	45	87	785	32 HTX-S	32HMTXSS	32HMTXB	140

Order codes shown are part of our current manufacturing programme.
Imperial and metric parts may vary in hexagon dimensions.

$$\frac{\text{PN (bar)}}{10} = \text{PN (MPa)}$$

Pressure ratings – PN shown, apply to Steel and Stainless Steel versions of the product.
For Brass parts reduce pressures by 35%

EMTX Union elbow

Triple-Lok® 37° Flare ends
SAE 070201 MS51505

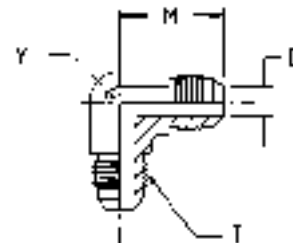

Tube mm	Tube O.D.		Thread UN/UNF-2A T	D mm	M mm	Y mm	Weight (steel) g/1 piece	Triple-Lok® Steel	Triple-Lok® Stainless Steel	Triple-Lok® Brass	PN (bar)
	in.										
6	1/8		5/16-24	2	20	11	18	2 ETX-S			500
	3/16		3/8-24	3	21	11	20	3 ETX-S			500
	1/4		7/16-20	4	23	11	25	4EMTXS	4EMTXSS	4 ETX-B	500
	5/16		1/2-20	6	24	13	32	5EMTXS	5EMTXSS	5 ETX-B	420
8	3/8		9/16-18	8	27	14	44	6EMTXS	6EMTXSS	6 ETX-B	420
10	3/8		5/16-24	8	27	14	40	6-4 ETX-S	6-4EMTXSS	6-4 ETX-B	420
12	1/2		3/4-16	10	32	19	88	8EMTXS	8EMTXSS	8 ETX-B	420
12	1/2		3/8-24	10	32	19	75	8-6 ETX-S	8-6EMTXSS		420
14, 15,16	5/8		7/8-14	12	37	22	139	10EMTXS	10EMTXSS	10 ETX-B	350
14, 15,16	5/8		7/8-14	12	37	22	120	10-8 ETX-S	10-8EMTXSS	10-8 ETX-B	350
18, 20	3/4		1 1/16-12	16	42	27	258	12EMTXS	12EMTXSS	12 ETX-B	350
18, 20	3/4		7/16-20	16	42	27	220	12-8 ETX-S	12-8EMTXSS		350
18, 20	3/4		3/4-16	16	42	27	240	12-10 ETX-S	12-10EMTXSS		350
22	7/8		1 3/16-12	18	44	30	273	14 ETX-S	14EMTXSS		280
22, 25	1		1 5/16-12	22	46	33	333	16EMTXS	16EMTXSS	16 ETX-B	280
22, 25	1		1/2-20	22	46	33	310	16-12 ETX-S	16-12EMTXSS	16-12 ETX-B	280
28, 30, 32	1 1/4		1 5/8-12	28	52	41	586	20EMTXS	20EMTXSS	20 ETX-B	280
35, 38	1 1/2		1 7/8-12	33	59	48	778	24EMTXS	24EMTXSS	24 ETX-B	210
	42		2 1/4-12	39	74	63	1100	28 ETX-S			140
	2		2 1/2-12	45	78	64	1680	32 ETX-S			140

Order codes shown are part of our current manufacturing programme.
Imperial and metric parts may vary in hexagon dimensions.

$$\frac{\text{PN (bar)}}{10} = \text{PN (MPa)}$$

Pressure ratings – PN shown, apply to Steel and Stainless Steel versions of the product.
For Brass parts reduce pressures by 35%

JMTX Union tee

Triple-Lok® 37° Flare end (three ends)
SAE 070401 MS51510

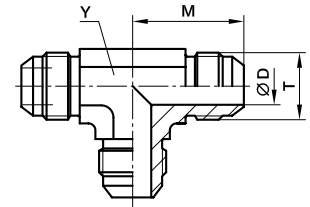

Tube O.D.		Thread UN/UNF-2A T	D mm	M mm	Y mm	Weight (steel) g/1 piece	Triple-Lok® Steel	Triple-Lok® Stainless Steel	Triple-Lok® Brass	PN (bar)
mm	in.									
6	1/8	5/16-24	2	20	8	25	2 JTX-S			500
	3/16	3/8-24	3	21	11	30	3 JTX-S			500
	1/4	7/16-20	4	23	11	33	4JMTXS	4JMTXSS	4 JTX-B	500
	5/16	1/2-20	6	24	13	42	5JMTXS	5JMTXSS	5 JTX-B	420
	3/8	9/16-18	8	27	14	53	6JMTXS	6JMTXSS	6 JTX-B	420
12	1/2	3/4-16	10	32	19	118	8JMTXS	8JMTXSS	8 JTX-B	420
14, 15, 16	5/8	7/8-14	12	37	22	182	10JMTXS	10JMTXSS	10 JTX-B	350
18, 20	3/4	1 1/16-12	16	42	27	291	12JMTXS	12JMTXSS	12 JTX-B	350
22	7/8	1 3/16-12	18	44	33	403	14 JTX-S	14JMTXSS	14 JTX-B	280
25	1	1 5/16-12	22	46	33	415	16JMTXS	16JMTXSS	16 JTX-B	280
28, 30, 32	1 1/4	1 5/8-12	28	52	41	706	20JMTXS	20JMTXSS	20 JTX-B	280
35, 38	1 1/2	1 7/8-12	33	59	48	990	24 JTX-S	24JMTXSS	24 JTX-B	210
42		2 1/4-12	39	74	63	2270	28 JTX-S			140
2		2 1/2-12	45	78	66	2450	32 JTX-S			140

Order codes shown are part of our current manufacturing programme.
Imperial and metric parts may vary in hexagon dimensions.

$$\frac{\text{PN (bar)}}{10} = \text{PN (MPa)}$$

Pressure ratings – PN shown, apply to Steel and Stainless Steel versions of the product.
For Brass parts reduce pressures by 35%



JMTX Union tee reducing

Triple-Lok® 37° Flare end (three ends)
SAE 070401 MS51510

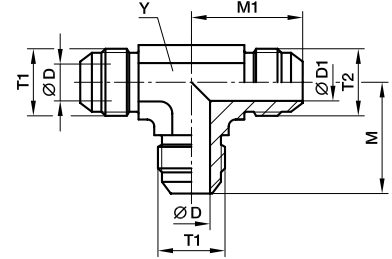

Tube 1 O.D.		Tube 2 O.D.		Thread UN/UNF-2A T1	Thread UN/UNF-2A T2	D mm	D1 mm	M mm	M1 mm	Y mm	Weight (steel) g/1 piece	Triple-Lok® Steel	Triple-Lok® Stainless Steel	PN (bar)
mm	in.	mm	in.											
10	3/8	6	1/4	9/16-20	7/16-20	8	4	27	27	14	50	6-4-6JMTXS	6-4-6JMTXSS	420
12	1/2	6	1/4	3/4-16	7/16-20	10	4	32	29	19	96	8-4-8JMTXS	8-4-8JMTXSS	420
12	1/2	10	3/8	3/4-16	9/16-18	10	8	32	29	19	102	8-6-8JMTXS	8-6-8JMTXSS	420
14, 15, 16	5/8	6	1/4	7/8-14	7/16-20	12	4	37	31	22	156	10-4-10JMTXS	10-4-10JMTXSS	350
14, 15, 16	5/8	10	3/8	7/8-14	9/16-18	12	8	37	31	22	167	10-6-10JMTXS	10-6-10JMTXSS	350
14, 15, 16	5/8	12	1/2	7/8-14	3/4-16	12	10	37	34	22	175	10-8-10JMTXS	10-8-10JMTXSS	350
18, 20	3/4	6	1/4	1 1/16-12	7/16-20	16	4	42	33	27	234	12-4-12JMTXS	12-4-12JMTXSS	350
18, 20	3/4	10	3/8	1 1/16-12	9/16-18	16	8	42	33	27	249	12-6-12JMTXS	12-6-12JMTXSS	350
18, 20	3/4	12	1/2	1 1/16-12	3/4-16	16	10	42	36	27	265	12-8-12JMTXS	12-8-12JMTXSS	350
18, 20	3/4	14/15/16	5/8	1 1/16-12	7/8-14	16	12	42	39	27	283	12-10-12JMTXS	12-10-12JMTXSS	350
25	1	10	3/8	1 5/16-12	9/16-18	22	8	46	36	33	326	16-6-16JMTXS	16-6-16JMTXSS	280
25	1	12	1/2	1 5/16-12	3/4-16	22	10	46	39	33	354	16-8-16JMTXS	16-8-16JMTXSS	280
25	1	14/15/16	5/8	1 5/16-12	7/8-14	22	12	46	42	33	379	16-10-16JMTXS	16-10-16JMTXSS	280
25	1	18/20	3/4	1 5/16-12	1 1/16-12	22	16	46	45	33	396	16-12-16JMTXS	16-12-16JMTXSS	280
28, 30, 32	1 1/4	12	1/2	1 5/8-12	3/4-16	28	10	52	44	41	478	20-8-20JMTXS	20-8-20JMTXSS	280
28, 30, 32	1 1/4	14/15/16	5/8	1 5/8-12	7/8-14	28	12	52	47	41	526	20-10-20JMTXS	20-10-20JMTXSS	280
28, 30, 32	1 1/4	18/20	3/4	1 5/8-12	1 1/16-12	28	16	52	50	41	628	20-12-20JMTXS	20-12-20JMTXSS	280
28, 30, 32	1 1/4	25	1	1 5/8-12	1 5/16-12	28	22	52	51	41	673	20-16-20JMTXS	20-16-20JMTXSS	280

Order codes shown are part of our current manufacturing programme.
Imperial and metric parts may vary in hexagon dimensions.

$$\frac{\text{PN (bar)}}{10} = \text{PN (MPa)}$$

Pressure ratings – PN shown, apply to Steel and Stainless Steel versions of the product.

JMTX Union tee reducing

Triple-Lok® 37° Flare end (three ends)
SAE 070401 MS51510

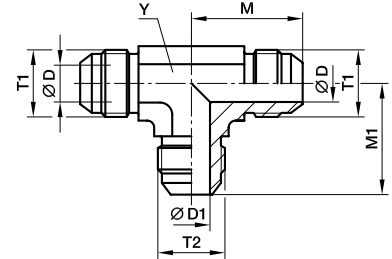

Tube 1 O.D.		Tube 2 O.D.		Thread UN/UNF-2A T1	Thread UN/UNF-2A T2	D mm	D1 mm	M mm	M1 mm	Y mm	Weight (steel) g/1 piece	Triple-Lok® Steel	Triple-Lok® Stainless Steel	PN (bar)
mm	in.	mm	in.											
10	3/8	6	1/4	9/16-18	7/16-20	8	4	27	27	14	50	6-6-4JMTXS	6-6-4JMTXSS	420
12	1/2	6	1/4	3/4-16	7/16-20	10	4	32	29	19	96	8-8-4JMTXS	8-8-4JMTXSS	420
12	1/2	10	3/8	3/4-16	9/16-18	10	8	32	29	19	102	8-8-6JMTXS	8-8-6JMTXSS	420
14, 15, 16	5/8	6	1/4	7/8-14	7/16-20	12	4	37	31	22	156	10-10-4JMTXS	10-10-4JMTXSS	350
14, 15, 16	5/8	10	3/8	7/8-14	9/16-18	12	8	37	31	22	167	10-10-6JMTXS	10-10-6JMTXSS	350
14, 15, 16	5/8	12	1/2	7/8-14	3/4-16	12	10	37	34	22	175	10-10-8JMTXS	10-10-8JMTXSS	350
18, 20	3/4	6	1/4	1 1/16-12	7/16-20	16	4	42	33	27	234	12-12-4JMTXS	12-12-4JMTXSS	350
18, 20	3/4	10	3/8	1 1/16-12	9/16-18	16	8	42	33	27	249	12-12-6JMTXS	12-12-6JMTXSS	350
18, 20	3/4	12	1/2	1 1/16-12	3/4-16	16	10	42	36	27	265	12-12-8JMTXS	12-12-8JMTXSS	350
18, 20	3/4	14/15/16	5/8	1 1/16-12	7/8-14	16	12	42	39	27	283	12-12-10JMTXS	12-12-10JMTXSS	350
25	1	10	3/8	1 5/16-12	9/16-18	22	8	46	36	33	326	16-16-6JMTXS	16-16-6JMTXSS	280
25	1	12	1/2	1 5/16-12	3/4-16	22	10	46	39	33	354	16-16-8JMTXS	16-16-8JMTXSS	280
25	1	14/15/16	5/8	1 5/16-12	7/8-14	22	12	46	42	33	379	16-16-10JMTXS	16-16-10JMTXSS	280
25	1	18/20	3/4	1 5/16-12	1 1/16-12	22	16	46	45	33	396	16-16-12JMTXS	16-16-12JMTXSS	280
28, 30, 32	1 1/4	12	1/2	1 5/8-12	3/4-16	28	10	52	44	41	478	20-20-8JMTXS	20-20-8JMTXSS	280
28, 30, 32	1 1/4	14/15/16	5/8	1 5/8-12	7/8-14	28	12	52	47	41	526	20-20-10JMTXS	20-20-10JMTXSS	280
28, 30, 32	1 1/4	18/20	3/4	1 5/8-12	1 1/16-12	28	16	52	50	41	628	20-20-12JMTXS	20-20-12JMTXSS	280
28, 30, 32	1 1/4	25	1	1 5/8-12	1 5/16-12	28	22	52	51	41	673	20-20-16JMTXS	20-20-16JMTXSS	280

Order codes shown are part of our current manufacturing programme.
Imperial and metric parts may vary in hexagon dimensions.

$$\frac{\text{PN (bar)}}{10} = \text{PN (MPa)}$$

Pressure ratings – PN shown, apply to Steel and Stainless Steel versions of the product.

KTX Union cross

Triple-Lok® 37° Flare end (four ends)
SAE 070501 MS51517

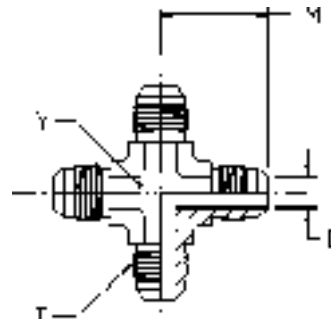

Tube O.D.		Thread UN/UNF-2A T	D mm	M mm	Y mm	Weight (steel) g/1 piece	Triple-Lok® Steel	Triple-Lok® Stainless Steel	Triple-Lok® Brass	PN (bar)
mm	in.									
6	1/4	7/16-20	4	23	11	41	4 KTX-S	4 KTX-SS	4 KTX-B	500
8	5/16	1/2-20	6	24	14	50	5 KTX-S	5 KTX-SS	5 KTX-B	420
10	3/8	9/16-18	8	27	14	68	6 KTX-S	6 KTX-SS	6 KTX-B	420
12	1/2	3/4-16	10	32	19	144	8 KTX-S	8 KTX-SS	8 KTX-B	420
14, 15, 16	5/8	7/8-14	12	37	22	220	10 KTX-S	10 KTX-SS	10 KTX-B	350
18, 20	3/4	1 1/16-12	16	42	27	345	12 KTX-S	12 KTX-SS	12 KTX-B	350
25	1	1 5/16-12	22	46	33	588	16 KTX-S	16 KTX-SS	16 KTX-B	280

Order codes shown are part of our current manufacturing programme.
Imperial and metric parts may vary in hexagon dimensions.

$$\frac{\text{PN (bar)}}{10} = \text{PN (MPa)}$$

Pressure ratings – PN shown, apply to Steel and Stainless Steel versions of the product.
For Brass parts reduce pressures by 35%

WMTX Bulkhead union

Triple-Lok® 37° Flare ends
SAE 070601 MS51520

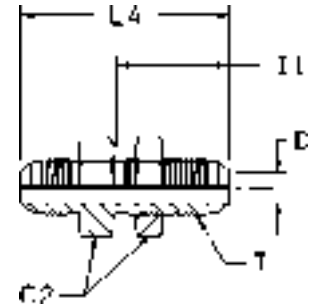

Tube O.D.		Thread UN/UNF-2A T	C2 mm	D mm	I1 mm	L4 mm	Weight (steel) g/1 piece	Triple-Lok® Steel	Triple-Lok® Stainless Steel	Triple-Lok® Brass	PN (bar)
mm	in.										
6	1/4	7/16-20	17	4	31	53	41	4WMTXWLNMS	4WMTXWLNMS	4WMTXWLNMB	500
8	5/16	1/2-20	19	6	31	53	49	5WMTXWLNMS	5WMTXWLNMS	5WMTXWLNMB	420
10	3/8	9/16-18	22	8	33	55	64	6WMTXWLNMS	6WMTXWLNMS	6WMTXWLNMB	420
12	1/2	3/4-16	24	10	37	62	111	8WMTXWLNMS	8WMTXWLNMS	8WMTXWLNMB	420
14, 15, 16	5/8	7/8-14	30	12	40	70	157	10WMTXWLNMS	10WMTXWLNMS	10WMTXWLNMB	350
18, 20	3/4	1 1/16-12	36	16	44	79	254	12WMTXWLNMS	12WMTXWLNMS	12WMTXWLNMB	350
22	7/8	1 3/16-12	38	18	45	80	296	14 WTX-WLN-S	14WMTXWLNMS	14WMTXWLNMB	280
25	1	1 5/16-12	41	22	44	80	337	16WMTXWLNMS	16WMTXWLNMS	16WMTXWLNMB	280
28, 30, 32	1 1/4	1 5/8-12	50	28	46	84	462	20WMTXWLNMS	20WMTXWLNMS	20WMTXWLNMB	280
35, 38	1 1/2	1 7/8-12	55	33	46	89	695	24WMTXWLNMS	24WMTXWLNMS	24WMTXWLNMB	210

Order codes shown are part of our current manufacturing programme. Imperial and metric parts may vary in hexagon dimensions.

For the version without the locknut remove "WLNMB" (e. g. 16WMTX)

$$\frac{\text{PN (bar)}}{10} = \text{PN (MPa)}$$

Pressure ratings – PN shown, apply to Steel and Stainless Steel versions of the product. For Brass parts reduce pressures by 35%

Maximum bulkhead wallthickness

Size	Tube O.D.		Straight bulkhead union Max. thickness mm	Shape bulkhead union Max. thickness mm
	inch	metric		
4	1/4	6	8.4	5.3
5	5/16	8	8.4	5.3
6	3/8	10	10.7	7.1
8	1/2	12	11.2	8.4
10	5/8	14–16	10.9	8.1
12	3/4	18–20	11.2	8.6
14	7/8		10.4	7.9
16	1	22–25	9.9	7.4
20	1 1/4	28–32	10.2	7.4
24	1 1/2	35–38	7.1	—
32	2		7.1	—



WEMTX Bulkhead union elbow

Triple-Lok® 37° Flare ends
SAE 070701 MS51507

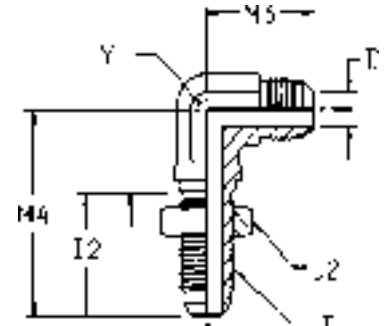

Tube O.D.		Thread UN/UNF-2A T	C2 mm	D mm	I2 mm	M3 mm	M4 mm	Y mm	Weight (steel) g/1 piece	Triple-Lok® Steel	Triple-Lok® Stainless Steel	Triple-Lok® Brass	PN (bar)
mm	in.												
6	1/4	7/16-20	17	4	26	25	40	11	44	4WEMTXWLNMS	4 WETX-WLN-SS	4 WETX-WLN-B	500
8	5/16	1/2-20	19	6	26	27	44	13	59	5WEMTXWLNMS	5 WETX-WLN-SS	5 WETX-WLN-B	420
10	3/8	9/16-18	22	8	28	28	46	14	72	6WEMTXWLNMS	6 WETX-WLN-SS	6 WETX-WLN-B	420
12	1/2	3/4-16	24	10	32	36	54	19	145	8WEMTXWLNMS	8 WETX-WLN-SS	8 WETX-WLN-B	420
14, 15, 16	5/8	7/8-14	30	12	35	40	61	22	212	10WEMTXWLNMS	10 WETX-WLN-SS	10 WETX-WLN-B	350
18, 20	3/4	1 1/16-12	36	16	40	45	68	27	345	12WEMTXWLNMS	12 WETX-WLN-SS	12 WETX-WLN-B	350
22	7/8	1 3/16-12	38	18	40	49	71	41	370	14 WETX-WLN-S	14 WETX-WLN-SS		280
25	1	1 5/16-12	41	22	40	49	71	41	474	16 WETX-WLN-S	16 WETX-WLN-SS		280
28, 30, 32	1 1/4	1 5/8-12	48	28	41	55	80	41	753	20 WETX-WLN-S	20 WETX-WLN-SS		280

Order codes shown are part of our current manufacturing programme.
Imperial and metric parts may vary in hexagon dimensions.

For the version without the locknut remove "WLN" (e. g. 16WMTX)

$$\frac{\text{PN (bar)}}{10} = \text{PN (MPa)}$$

Pressure ratings – PN shown, apply to Steel and Stainless Steel versions of the product.
For Brass parts reduce pressures by 35%

Maximum bulkhead wallthickness

Size	Tube O.D.		Straight bulkhead union Max. thickness mm	Shape bulkhead union Max. thickness mm
	inch	metric		
4	1/4	6	8.4	5.3
5	5/16	8	8.4	5.3
6	3/8	10	10.7	7.1
8	1/2	12	11.2	8.4
10	5/8	14–16	10.9	8.1
12	3/4	18–20	11.2	8.6
14	7/8		10.4	7.9
16	1	22–25	9.9	7.4
20	1 1/4	28–32	10.2	7.4
24	1 1/2	35–38	7.1	—
32	2		7.1	—

WNTX 45° Bulkhead union elbow

Triple-Lok® 37° Flare ends
SAE 070801 MS51509

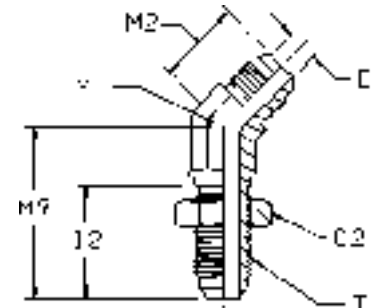

Tube O.D.		Thread UN/UNF-2A T	C2 mm	D mm	I2 mm	M2 mm	M9 mm	Y mm	Weight (steel) g/1 piece	Triple-Lok® Steel	Triple-Lok® Stainless Steel	PN (bar)
mm	in.											
6	1/4	7/16-20	17	4	26	18	39	11	32	4 WNTX-WLN-S	4 WNTX-WLN-SS	500
8	5/16	1/2-20	19	6	26	20	42	14	41	5 WNTX-WLN-S	5 WNTX-WLN-SS	420
10	3/8	9/16-18	21	8	28	21	42	14	48	6 WNTX-WLN-S	6 WNTX-WLN-SS	420
12	1/2	3/4-16	25	10	32	25	49	19	105	8 WNTX-WLN-S	8 WNTX-WLN-SS	420
14, 15, 16	5/8	7/8-14	29	12	35	28	55	22	152	10 WNTX-WLN-S	10 WNTX-WLN-SS	350
18, 20	3/4	1 1/16-12	35	16	40	33	62	27	245	12 WNTX-WLN-S	12 WNTX-WLN-SS	350
22, 25	1	1 5/16-12	41	22	40	37	65	33	355	16 WNTX-WLN-S	16 WNTX-WLN-SS	280
28, 30, 32	1 1/4	1 5/8-12	48	28	41	40	67	41	465	20 WNTX-WLN-S	20 WNTX-WLN-SS	280

Order codes shown are part of our current manufacturing programme.
Imperial and metric parts may vary in hexagon dimensions.

For the version without the locknut remove "WLN" (e.g. 16 WNTX)

$$\frac{\text{PN (bar)}}{10} = \text{PN (MPa)}$$

Pressure ratings – PN shown, apply to Steel and Stainless Steel versions of the product.

Maximum bulkhead wallthickness

Size	Tube O.D.		Straight bulkhead union Max. thickness mm	Shape bulkhead union Max. thickness mm
	inch	metric		
4	1/4	6	8.4	5.3
5	5/16	8	8.4	5.3
6	3/8	10	10.7	7.1
8	1/2	12	11.2	8.4
10	5/8	14–16	10.9	8.1
12	3/4	18–20	11.2	8.6
14	7/8		10.4	7.9
16	1	22–25	9.9	7.4
20	1 1/4	28–32	10.2	7.4
24	1 1/2	35–38	7.1	—
32	2		7.1	—

WJTX Bulkhead branch tee

Triple-Lok® 37° Flare ends
SAE 070959 MS51515

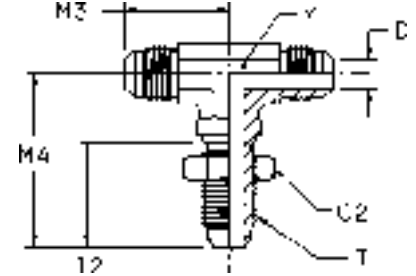

Tube O.D.		Thread UN/UNF-2A T	C2 mm	D mm	I2 mm	M3 mm	M4 mm	Y mm	Weight (steel) g/1 piece	Triple-Lok® Steel	Triple-Lok® Stainless Steel	PN (bar)
mm	in.											
6	1/4	7/16-20	17	4	26	25	40	11	45	4 WJTX-WLN-S	4 WJTX-WLN-SS	500
10	3/8	9/16-18	21	8	28	28	46	14	71	6 WJTX-WLN-S	6 WJTX-WLN-SS	420
12	1/2	3/4-16	25	10	32	35	54	19	158	8 WJTX-WLN-S	8 WJTX-WLN-SS	420
14, 15, 16	5/8	7/8-14	29	12	35	40	61	22	297	10 WJTX-WLN-S	10 WJTX-WLN-SS	350
18, 20	3/4	1 1/16-12	35	16	40	45	68	27	379	12 WJTX-WLN-S	12 WJTX-WLN-SS	350
22, 25	1	1 5/16-12	42	22	40	49	71	33	420	16 WJTX-WLN-S		280
28, 30, 32	1 1/4	1 5/8-12	48	28	41	55	79	41	500	20 WJTX-WLN-S		280

Order codes shown are part of our current manufacturing programme.
Imperial and metric parts may vary in hexagon dimensions.

For the version without the locknut remove "WLN" (e.g. 16 WJTX)

$$\frac{\text{PN (bar)}}{10} = \text{PN (MPa)}$$

Pressure ratings – PN shown, apply to Steel and Stainless Steel versions of the product.

Maximum bulkhead wallthickness

Size	Tube O.D.		Straight bulkhead union Max. thickness mm	Shape bulkhead union Max. thickness mm
	inch	metric		
4	1/4	6	8.4	5.3
5	5/16	8	8.4	5.3
6	3/8	10	10.7	7.1
8	1/2	12	11.2	8.4
10	5/8	14–16	10.9	8.1
12	3/4	18–20	11.2	8.6
14	7/8		10.4	7.9
16	1	22–25	9.9	7.4
20	1 1/4	28–32	10.2	7.4
24	1 1/2	35–38	7.1	—
32	2		7.1	—

WJJTX Bulkhead run tee

Triple-Lok® 37° Flare ends
SAE 070958 MS51516

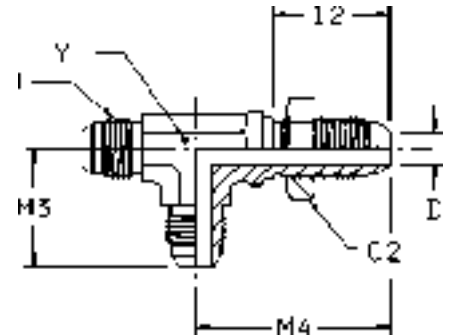

Tube O.D.		Thread UN/UNF-2A T	C2 mm	D mm	l2 mm	M3 mm	M4 mm	Y mm	Weight (steel) g/1 piece	Triple-Lok® Steel	PN (bar)
mm	in.										
6	1/4	7/16-20	17	4	26	25	40	11	58	4 WJJTX-WLN-S	500
10	3/8	9/16-18	21	8	28	28	46	14	75	6 WJJTX-WLN-S	420
12	1/2	3/4-16	25	10	32	35	54	19	158	8 WJJTX-WLN-S	420
14, 15, 16	5/8	7/8-14	29	12	35	40	61	22	309	10 WJJTX-WLN-S	350
18, 20	3/4	1 1/16-12	35	16	40	45	68	27	340	12 WJJTX-WLN-S	350
22, 25	1	1 5/16-12	42	22	40	49	71	36	390	16 WJJTX-WLN-S	280
28, 30, 32	1 1/4	1 5/8-12	48	28	41	55	79	41	450	20 WJJTX-WLN-S	280

Order codes shown are part of our current manufacturing programme.
Imperial and metric parts may vary in hexagon dimensions.

For the version without the locknut remove "WLN" (e.g. 16 WJJTX)

$$\frac{\text{PN (bar)}}{10} = \text{PN (MPa)}$$

Maximum bulkhead wallthickness

Size	Tube O.D.		Straight bulkhead union Max. thickness mm	Shape bulkhead union Max. thickness mm
	inch	metric		
4	1/4	6	8.4	5.3
5	5/16	8	8.4	5.3
6	3/8	10	10.7	7.1
8	1/2	12	11.2	8.4
10	5/8	14-16	10.9	8.1
12	3/4	18-20	11.2	8.6
14	7/8		10.4	7.9
16	1	22-25	9.9	7.4
20	1 1/4	28-32	10.2	7.4
24	1 1/2	35-38	7.1	—
32	2		7.1	—

C6MX Swivel nut elbow

Triple-Lok® 37° Flare end / Triple-Lok® 37° Flare female swivel end
SAE 070221 MS51521

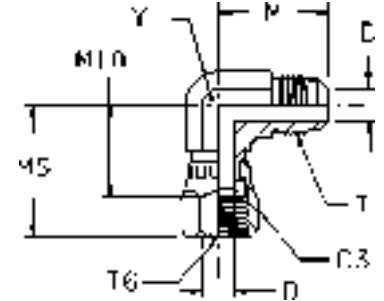

Tube O.D.		Thread UN/UNF-2A T	Thread UN/UNF-2B T6	C3 mm	D mm	M mm	M5 mm	M10 mm	Y mm	Weight (steel) g/1 piece	Triple-Lok® Steel	Triple-Lok® Stainless Steel	PN (bar)
6	3/16	3/8-24	3/8-24	13	3	21	25	16	11	27	3 C6X-S		500
	1/4	7/16-20	7/16-20	16	4	23	25	17	11	37	4C6MXS	4C6MXSS	500
8	5/16	1/2-20	1/2-20	17	6	24	27	17	13	43	5C6MXS	5C6MXSS	420
10	3/8	9/16-18	9/16-18	19	8	27	32	22	14	54	6C6MXS	6C6MXSS	350
12	1/2	3/4-16	3/4-16	22	10	32	35	24	19	105	8C6MXS	8C6MXSS	350
14, 15, 16	5/8	7/8-14	7/8-14	27	12	37	41	28	22	162	10C6MXS	10C6MXSS	350
18, 20	3/4	1 1/16-12	1 1/16-12	32	16	42	44	30	27	260	12C6MXS	12C6MXSS	350
22	7/8	1 3/16-12	1 3/16-12	35	18	46	45	34	33	293	14 C6X-S	14C6MXSS	250
25	1	1 5/16-12	1 5/16-12	38	22	46	51	36	33	420	16C6MXS	16C6MXSS	250
28, 30, 32	1 1/4	1 5/8-12	1 5/8-12	50	28	52	59	43	41	679	20C6MXS	20C6MXSS	250
35, 38	1 1/2	1 7/8-12	1 7/8-12	57	33	59	66	47	48	747	24 C6X-S	24C6MXSS	170
	2	2 1/2-12	2 1/2-12	73	45	78	89	62	66	920	32 C6X-S		110

Order codes shown are part of our current manufacturing programme.
Imperial and metric parts may vary in hexagon dimensions.

$$\frac{PN \text{ (bar)}}{10} = PN \text{ (MPa)}$$

Pressure ratings – PN shown, apply to Steel and Stainless Steel versions of the product.

V6MX 45° Swivel nut elbow

Triple-Lok® 37° Flare end / Triple-Lok® 37° Flare female swivel end
SAE 070321 MS51522

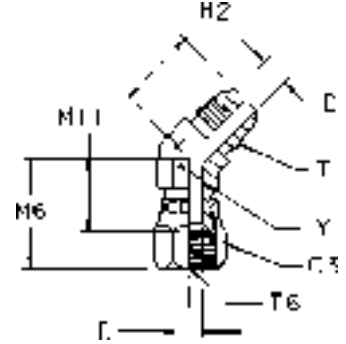

Tube O.D.		Thread UN/UNF-2A	Thread UN/UNF-2B	C3	D	M2	M6	M11	Y	Weight (steel)	Triple-Lok® Steel	Triple-Lok® Stainless Steel	PN (bar)
mm	in.	T	T6	mm	mm	mm	mm	mm	mm	g/1 piece			
6	1/4	7/16-20	7/16-20	14	4	18	24	15	11	30	4 V6X-S	4 V6X-SS	500
8	5/16	1/2-20	1/2-20	16	6	20	25	16	14	45	5 V6X-S	5 V6X-SS	420
10	3/8	9/16-18	9/16-18	19	8	21	28	19	14	47	6V6MXS	6 V6X-SS	350
12	1/2	3/4-16	3/4-16	22	10	25	33	22	19	89	8V6MXS	8 V6X-SS	350
14, 15, 16	5/8	7/8-14	7/8-14	27	12	28	37	24	22	131	10V6MXS	10 V6X-SS	350
18, 20	3/4	1 1/16-12	1 1/16-12	32	16	33	38	24	27	203	12V6MXS	12 V6X-SS	350
22	7/8	1 3/16-12	1 3/16-12	35	18	35	41	28	30	291	14 V6X-S		250
25	1	1 5/16-12	1 5/16-12	38	22	37	44	29	33	335	16V6MXS	16 V6X-SS	250
28, 30, 32	1 1/4	1 5/8-12	1 5/8-12	51	27	40	52	36	41	572	20 V6X-S	20 V6X-SS	250
35, 38	1 1/2	1 7/8-12	1 7/8-12	57	33	45	58	39	48	715	24 V6X-S	24 V6X-SS	170
	2	2 1/2-12	2 1/2-12	72	45	56	70	50	66	960	32 V6X-S	32 V6X-SS	110

Order codes shown are part of our current manufacturing programme.
Imperial and metric parts may vary in hexagon dimensions.

$$\frac{\text{PN (bar)}}{10} = \text{PN (MPa)}$$

Pressure ratings – PN shown, apply to Steel and Stainless Steel versions of the product.

K

S6MX Swivel nut branch tee

Triple-Lok® 37° Flare ends / Triple-Lok® 37° Flare female swivel end
SAE 070433 MS51524

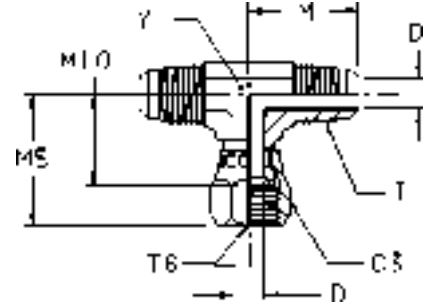

Tube O.D.		Thread UN/UNF-2A T	Thread UN/UNF-2B T6	C3 mm	D mm	M mm	M5 mm	M10 mm	Y mm	Weight (steel) g/1 piece	Triple-Lok® Steel	Triple-Lok® Stainless Steel	PN (bar)
6	1/4	7/16-20	7/16-20	16	4	23	25	17	11	44	4S6MXS	4 S6X-SS	500
8	5/16	1/2-20	1/2-20	17	6	24	27	17	13	58	5S6MXS	5 S6X-SS	420
10	3/8	9/16-18	9/16-18	19	8	27	32	22	14	71	6S6MXS	6 S6X-SS	350
12	1/2	3/4-16	3/4-16	22	10	32	35	24	19	133	8S6MXS	8 S6X-SS	350
14, 15, 16	5/8	7/8-14	7/8-14	27	12	37	41	28	22	203	10S6MXS	10 S6X-SS	350
18, 20	3/4	1 1/16-12	1 1/16-12	32	16	42	44	30	27	328	12S6MXS	12 S6X-SS	350
25	1	1 5/16-12	1 5/16-12	38	22	46	51	36	33	483	16S6MXS	16 S6X-SS	250
28, 30, 32	1 1/4	1 5/8-12	1 5/8-12	50	28	52	59	43	41	708	20 S6X-S	20 S6X-SS	250
35, 38	1 1/2	1 7/8-12	1 7/8-12	57	33	59	68	49	48	1100	24 S6X-S	24 S6X-SS	170

Order codes shown are part of our current manufacturing programme.
Imperial and metric parts may vary in hexagon dimensions.

$$\frac{\text{PN (bar)}}{10} = \text{PN (MPa)}$$

Pressure ratings – PN shown, apply to Steel and Stainless Steel versions of the product.

R6MX Swivel nut run tee

Triple-Lok® 37° Flare ends / Triple-Lok® 37° Flare female swivel end
SAE 070432

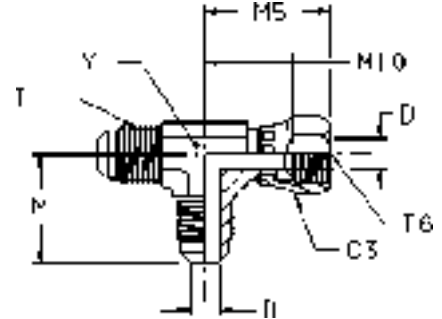

Tube O.D.		Thread UN/UNF-2A	Thread UN/UNF-2B	C3	D	M	M5	M10	Y	Weight (steel)	Triple-Lok® Steel	Triple-Lok® Stainless Steel	PN (bar)
mm	in.	T	T6	mm	mm	mm	mm	mm	mm	g/1 piece			
6	1/4	7/16-20	7/16-20	16	4	23	25	17	11	44	4R6MXS	4 R6X-SS	500
8	5/16	1/2-20	1/2-20	17	6	24	27	17	13	56	5R6MXS	5 R6X-SS	420
10	3/8	9/16-18	9/16-18	19	8	27	32	22	14	69	6R6MXS	6 R6X-SS	350
12	1/2	3/4-16	3/4-16	22	10	32	35	24	19	136	8R6MXS	8 R6X-SS	350
14, 15, 16	5/8	7/8-14	7/8-14	27	12	37	41	28	22	207	10R6MXS	10 R6X-SS	350
18, 20	3/4	1 1/16-12	1 1/16-12	32	16	42	44	30	27	319	12R6MXS	12 R6X-SS	350
22	7/8	1 3/16-12	1 3/16-12	35	18	46	45	34	33	622	14 R6X-S	14 R6X-SS	250
25	1	1 5/16-12	1 5/16-12	38	22	46	51	36	33	489	16R6MXS	16 R6X-SS	250
28, 30, 32	1 1/4	1 5/8-12	1 5/8-12	50	28	52	59	43	41	712	20R6MXS	20 R6X-SS	250
35, 38	1 1/2	1 7/8-12	1 7/8-12	57	33	59	66	47	48	1100	24 R6X-S	24 R6X-SS	170

Order codes shown are part of our current manufacturing programme.
Imperial and metric parts may vary in hexagon dimensions.

$$\frac{\text{PN (bar)}}{10} = \text{PN (MPa)}$$

Pressure ratings – PN shown, apply to Steel and Stainless Steel versions of the product.

K

BBMTX Swivel nut female connector

Triple-Lok® 37° Flare fixed female end / Triple-Lok® 37° Flare female swivel end

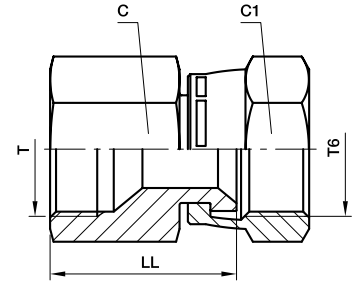

Tube O.D.		Thread UN/UNF-2A T	Thread UN/UNF-2B T6	C mm	C1 mm	LL mm	Weight (steel) g/1 piece	Triple-Lok® Steel	Triple-Lok® Stainless Steel	PN (bar)
mm	in.									
6	1/4	7/16-20	7/16-20	14	16	23	25	4BBMTXS	4BBMTXSS	500
8	5/16	1/2-20	1/2-20	17	17	26	32	5BBMTXS	5BBMTXSS	420
10	3/8	9/16-20	9/16-20	19	19	26	60	6BBMTXS	6BBMTXSS	350
12	1/2	3/4-16	3/4-16	22	22	32	87	8BBMTXS	8BBMTXSS	350
14, 15, 16	5/8	7/8-14	7/8-14	27	27	36	150	10BBMTXS	10BBMTXSS	350
18, 20	3/4	1 1/16-12	1 1/16-12	32	32	37	221	12BBMTXS	12BBMTXSS	350
25	1	1 5/16-12	1 5/16-12	41	38	42	348	16BBMTXS	16BBMTXSS	250
28, 30, 32	1 1/4	1 5/8-12	1 5/8-12	50	50	47	955	20BBMTXS	20BBMTXSS	250
35, 38	1 1/2	1 7/8-12	1 7/8-12	60	60	54	1031	24BBMTXS	24BBMTXSS	170

Order codes shown are part of our current manufacturing programme.
Imperial and metric parts may vary in hexagon dimensions.

$$\frac{\text{PN (bar)}}{10} = \text{PN (MPa)}$$

Pressure ratings – PN shown, apply to Steel and Stainless Steel versions of the product.

TRMTX Tube end reducer

Triple-Lok® 37° Flare end / Triple-Lok® 37° Flare female swivel* end
SAE 070123 MS51534

*Form A Fixed Female Style

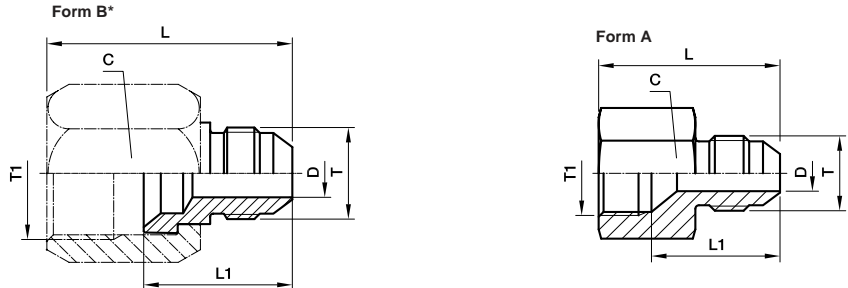

* For Form B, a BTX- or BTMX-nut is required (to be ordered separately)

Tube Metric T1 O.D.	Tube Metric T O.D.	Tube in. T1 O.D.	Tube in. T O.D.	Thread UN/UNF-2B T1	Thread UN/UNF-2A T	Typ	C mm	D mm	L mm	L1 mm	Weight (steel) g/1 piece	Triple-Lok® Steel	Triple-Lok® Stainless Steel	Triple-Lok® Brass	PN (bar)
8	6	1/4	1/8	7/16-20	5/16-24	B	14	2	31	19	16	4-2TRTXS	4-2TRMTXSS		500
10	6	3/8	1/4	1/2-20	7/16-20	A	17	4	27	24	21	5-4TRMTXSS	5-4TRMTXSS		420
10	8	3/8	1/4	9/16-18	7/16-20	B	19	4	36	23	35	6-4TRTXS	6-4TRMTXSS	6-4 TRTX-B	420
10	8	3/8	5/16	9/16-18	1/2-20	A	19	6	29	26	29	6-5TRMTXSS	6-5TRMTXSS		420
12	6	1/2	1/4	3/4-16	7/16-20	B	22	4	38	23	38	8-4TRTXS	8-4TRMTXSS	8-4 TRTX-B	420
12	8	1/2	5/16	3/4-16	1/2-20	B	22	6	38	23	35	8-5TRTXS	8-5TRMTXSS		420
12	10	1/2	3/8	3/4-16	9/16-20	B	22	8	38	23	32	8-6TRTXS	8-6TRMTXSS	8-6 TRTX-B	420
14, 15, 16	6	5/8	1/4	7/8-14	7/16-20	B	27	4	45	26	83	10-4TRTXS	10-4TRMTXSS		350
14, 15, 16	8	5/8	5/16	7/8-14	1/2-20	B	27	6	41	26	80	10-5TRTXS	10-5TRMTXSS		350
14, 15, 16	10	5/8	3/8	7/8-14	9/16-20	B	27	8	41	29	78	10-6TRTXS	10-6TRMTXSS	10-6 TRTX-B	350
14, 15, 16	12	5/8	1/2	7/8-14	3/4-16	A	27	10	37	22	73	10-8TRMTXSS	10-8TRMTXSS		350
18, 20	6	3/4	1/4	1 1/16-12	7/16-20	B	32	4	47	28	120	12-4TRTXS	12-4TRMTXSS	12-4 TRTX-B	350
18, 20	8	3/4	5/16	1 1/16-12	1/2-20	B	32	6	45	26	118	12-5TRTXS	12-5TRMTXSS		350
18, 20	10	3/4	3/8	1 1/16-12	9/16-20	B	32	8	47	25	115	12-6TRTXS	12-6TRMTXSS	12-6 TRTX-B	350
18, 20	12	3/4	1/2	1 1/16-12	3/4-16	B	32	10	50	27	128	12-8TRTXS	12-8TRMTXSS	12-8 TRTX-B	350
18, 20	14, 15, 16	3/4	5/8	1 1/16-12	7/8-14	A	32	12	42	26	119	12-10TRMTXSS	12-10TRMTXSS		350
22	10	7/8	3/8	1 3/16-12	9/16-20	B	35	8	50	29	102	14-6TRTXS	14-6TRMTXSS		350
22	14, 15, 16	7/8	5/8	1 3/16-12	7/8-14	B	35	12	55	34	120	14-10TRTXS	14-10TRMTXSS		350
22	18, 20	7/8	3/4	1 3/16-12	1 1/16-12	A	35	16	47	33	166	14-12 TRTXN-S	14-12TRMTXSS		350
25	6	1	1/4	7/16-20	1 5/16-12	B	41	4	53	31	205	16-4TRTXS	16-4TRMTXSS		310
25	10	1	3/8	9/16-18	1 5/16-12	B	41	8	48	31	215	16-6TRTXS	16-6TRMTXSS		310
25	12	1	1/2	1 5/16-12	3/4-16	B	41	10	49	29	228	16-8TRTXS	16-8TRMTXSS		310
25	14, 15, 16	1	5/8	1 5/16-12	7/8-14	B	41	12	52	30	239	16-10TRTXS	16-10TRMTXSS		310
25	18, 20	1	3/4	1 5/16-12	1 1/16-12	B	41	16	55	35	252	16-12TRTXS	16-12TRMTXSS		310
25	22	1	7/8	1 5/16-12	1 3/16-12	A	38	18	60	38	224	16-14 TRTXN-S	16-14TRMTXSS		310
28, 30, 32	14, 15, 16	1 1/4	5/8	1 5/8-12	7/8-14	B	50	12	59	32	380	20-10TRTXS	20-10TRMTXSS		280
28, 30, 32	18, 20	1 1/4	3/4	1 5/8-12	1 1/16-12	B	50	16	62	39	370	20-12TRTXS	20-12TRMTXSS		280
28, 30, 32	25	1 1/4	1	1 5/8-12	1 5/16-12	B	50	21	64	40	355	20-16TRTXS	20-16TRMTXSS		280
35, 38	20	1 1/2	3/4	1 1/16-12	1 7/8-12	B	60	16	63	41	520	24-12TRTXS	24-12TRMTXSS		210
35, 38	25	1 1/2	1	1 5/16-12	1 7/8-12	B	60	22	63	41	570	24-16TRTXS	24-16TRMTXSS		210
35, 38	28, 30, 32	1 1/2	1 1/4	1 7/8-12	1 5/8-12	B	60	27	70	43	614	24-20TRTXS	24-20TRMTXSS		210
42	35, 38			2 1/4-12	1 7/8-12	B	65	33	72	42	839	28-24TRTXS	28-24TRMTXSS		140
50	38	2	1 1/2	1 7/8-12	2 1/2-12	B	70	34	75	49	900	32-24TRTXS			140

Order codes shown are part of our current manufacturing programme.
Imperial and metric parts may vary in hexagon dimensions.

$$\frac{PN \text{ (bar)}}{10} = PN \text{ (MPa)}$$

Pressure ratings – PN shown, apply to Steel and Stainless Steel versions of the product.
For Brass parts reduce pressures by 35%



HMX6 Swivel nut union

Triple-Lok® 37° Flare female swivel ends

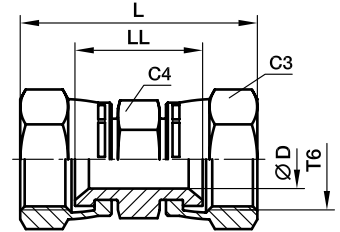

Tube O.D.		Thread UN/UNF-2B T6	C3 mm	C4 mm	D mm	L mm	LL mm	Weight (steel) g/1 piece	Triple-Lok® Steel	Triple-Lok® Stainless Steel	PN (bar)
mm	in.										
6	1/4	7/16-20	14	14	5	38	20	27	4 HX6-S	4HMX6SS	500
8, 10	5/16, 3/8	9/16-18	18	18	8	45	26	35	6 HX6-S	6HMX6SS	350
12	1/2	3/4-16	22	22	10	51	30	64	8 HX6-S	8HMX6SS	350
14, 15, 16	5/8	7/8-14	25	25	13	57	32	115	10 HX6-S	10HMX6SS	350
18, 20	3/4	1 1/16-12	32	32	16	62	33	185	12 HX6-S	12HMX6SS	350
25	1	1 5/16-12	41	41	22	68	38	235	16 HX6-S	16HMX6SS	250

Order codes shown are part of our current manufacturing programme. Imperial and metric parts may vary in hexagon dimensions.

$$\frac{\text{PN (bar)}}{10} = \text{PN (MPa)}$$

Pressure ratings - PN shown, apply to Steel and Stainless Steel versions of the product.

JX6 Swivel nut union tee

Triple-Lok® 37° Flare female swivel ends

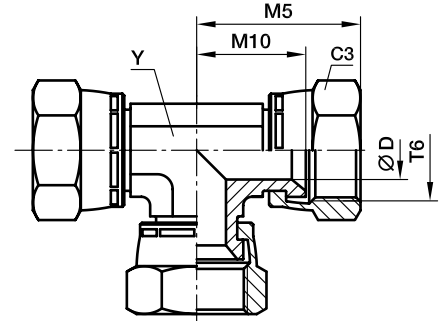

Tube O.D.		Thread UN/UNF-2B T6	C3 mm	D mm	M5 mm	M10 mm	Y mm	Weight (steel) g/1 piece	Triple-Lok® Steel	PN (bar)
mm	in.									
6	1/4	7/16-20	14	5	25	17	11	55	4 JX6-S	500
8, 10	5/16, 3/8	9/16-18	18	8	32	22	14	85	6 JX6-S	350
12	1/2	3/4-16	22	10	35	24	19	150	8 JX6-S	350
14, 15, 16	5/8	7/8-14	25	13	41	29	19	220	10 JX6-S	350
18, 20	3/4	1 1/16-12	32	16	45	30	27	345	12 JX6-S	350
25	1	1 5/16-12	41	22	51	36	30	510	16 JX6-S	250

Order codes shown are part of our current manufacturing programme.
Imperial and metric parts may vary in hexagon dimensions.

$$\frac{\text{PN (bar)}}{10} = \text{PN (MPa)}$$

K

F87OMX Male stud connector

Triple-Lok® 37° Flare end / Male metric thread – O-ring (ISO 6149)

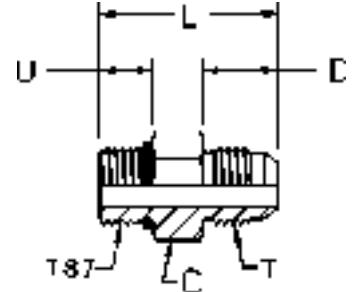

Tube O.D.		Thread Metric T87	Thread UN/UNF-2A T	L mm	D mm	C mm	U mm	Weight (steel) g/1 piece	Triple-Lok® Steel	Triple-Lok® Stainless Steel	PN (bar)
mm	in.										
6	1/4	M10 1.0	7/16-20	30	14	14	9	25	4M10F87OMXS	4M10F87OMXSS	500
8	5/16	M10 1.0	1/2-20	30	14	14	9	30	5M10F87OMXS	5M10F87OMXSS	420
8	5/16	M12 1.5	1/2-20	33	14	19	11	37	5M12F87OMXS	5M12F87OMXSS	420
8	5/16	M14 1.5	1/2-20	34	14	19	11	40	5M14F87OMXS	5M14F87OMXSS	420
10	3/8	M14 1.5	9/16-18	34	14	19	11	44	6M14F87OMXS	6M14F87OMXSS	420
10	3/8	M16 1.5	9/16-18	36	14	22	12	53	6M16F87OMXS	6M16F87OMXSS	420
10	3/8	M18 1.5	9/16-18	37	14	24	13	60	6M18F87OMXS	6M18F87OMXSS	350
12	1/2	M14 1.5	3/4-16	36	17	19	11	41	8M14F87OMXS	8M14F87OMXSS	420
12	1/2	M16 1.5	3/4-16	38	17	22	12	57	8M16F87OMXS	8M16F87OMXSS	420
12	1/2	M18 1.5	3/4-16	39	17	24	13	71	8M18F87OMXS	8M18F87OMXSS	350
14, 15, 16	5/8	M14 1.5	7/8-14	41	19	24	11	73	10M14F87OMXS	10M14F87OMXSS	350
14, 15, 16	5/8	M18 1.5	7/8-14	43	19	24	13	75	10M18F87OMXS	10M18F87OMXSS	350
14, 15, 16	5/8	M22 1.5	7/8-14	44	19	27	13	98	10M22F87OMXS	10M22F87OMXSS	350
14, 15, 16	5/8	M27 2.0	7/8-14	46	19	32	16	75	10M27F87OMXS	10M27F87OMXSS	350
18, 20	3/4	M22 1.5	1 1/16-12	48	22	27	13	104	12M22F87OMXS	12M22F87OMXSS	350
18, 20	3/4	M27 2.0	1 1/16-12	51	22	32	16	158	12M27F87OMXS	12M27F87OMXSS	350
25	1	M27 2.0	1 5/16-12	51	23	36	16	206	16M27F87OMXS	16M27F87OMXSS	280
25	1	M33 2.0	1 5/16-12	53	23	41	16	273	16M33F87OMXS	16M33F87OMXSS	280
28, 30, 32	1 1/4	M42 2.0	1 5/8-12	55	24	50	16	431	20M42F87OMXS	20M42F87OMXSS	280
35, 38	1 1/2	M48 2.0	1 7/8-12	59	28	55	18	564	24M48F87OMXS	24M48F87OMXSS	210

Triple-Lok® is delivered with NBR elastomeric seals as standard. For more details on other seal materials see page K93
 Order codes shown are part of our current manufacturing programme.
 Imperial and metric parts may vary in hexagon dimensions.

$$\frac{\text{PN (bar)}}{10} = \text{PN (MPa)}$$

Pressure ratings – PN shown, apply to Steel and Stainless Steel versions of the product.

F5OMX Male stud connector

Triple-Lok® 37° Flare end / Male UN/UNF thread – O-ring (ISO 11926)
SAE 070120 MS51525

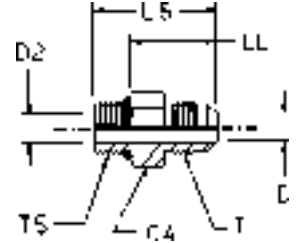

Tube O.D. mm	Tube O.D. in.	Thread UN/UNF-2A T5	Thread UN/UNF-2A T	C4 mm	D mm	D2 mm	L5 mm	LL mm	Weight (steel) g/1 piece	Triple-Lok® Steel	Triple-Lok® Stainless Steel	PN (bar)
6	1/8	5/16-24	5/16-24	11	2	2	27	19	8	2 F5OX-S		500
	3/16	3/8-24	3/8-24	13	3	3	28	20	10	3 F5OX-S		500
	3/16	5/16-24	3/8-24	13	3	2	28	20	9	3-2 F5OX-S		500
	1/4	7/16-20	7/16-20	14	4	4	31	22	15	4F5OMXS	4F5OMXSS	500
	1/4	3/8-24	7/16-20	14	5	3	30	23	12	4-3 F5OX-S	4-3F5OMXSS	500
6	1/4	1/2-20	7/16-20	16	4	6	31	22	25	4-5 F5OX-S	4-5F5OMXSS	420
6	1/4	9/16-18	7/16-20	17	4	4	33	23	27	4-6F5OMXS	4-6F5OMXSS	420
6	1/4	3/4-16	7/16-20	22	4	10	35	24	35	4-8 F5OX-S	4-8F5OMXSS	420
6	1/4	7/8-14	7/16-20	25	5	5	38	25	60	4-10 F5OX-S	4-10F5OMXSS	350
8	5/16	1/2-20	1/2-20	16	6	6	31	22	18	5F5OMXS	5F5OMXSS	420
8	5/16	7/16-20	1/2-20	14	6	5	31	22	18	5-4 F5OX-S	5-4F5OMXSS	420
8	5/16	9/16-18	1/2-20	17	6	6	33	23	25	5-6 F5OX-S	5-6F5OMXSS	420
8	5/16	3/4-16	1/2-20	22	6	6	35	24	40	5-8 F5OX-S	5-8F5OMXSS	420
10	3/8	9/16-18	9/16-18	17	8	8	33	23	25	6F5OMXS	6F5OMXSS	420
10	3/8	7/16-20	9/16-18	16	8	4	32	23	40	6-4 F5OX-S	6-4F5OMXSS	420
10	3/8	1/2-20	9/16-18	16	8	6	32	23	56	6-5 F5OX-S	6-5F5OMXSS	420
10	3/8	3/4-16	9/16-18	22	8	8	35	24	44	6-8F5OMXS	6-8F5OMXSS	420
10	3/8	7/8-14	9/16-18	25	8	12	38	25	85	6-10 F5OX-S	6-10F5OMXSS	350
10	3/8	1 1/16-12	9/16-18	32	8	16	42	27	100	6-12 F5OX-S	6-12F5OMXSS	350
12	1/2	3/4-16	3/4-16	22	10	10	38	27	58	8F5OMXS	8F5OMXSS	420
12	1/2	7/16-20	3/4-16	21	10	5	38	29	40	8-4 F5OX-S	8-4F5OMXSS	420
12	1/2	9/16-18	3/4-16	19	10	10	37	27	44	8-6F5OMXS	8-6F5OMXSS	420
12	1/2	7/8-14	3/4-16	27	10	10	41	28	73	8-10F5OMXS	8-10F5OMXSS	350
12	1/2	1 1/16-12	3/4-16	32	10	10	45	30	126	8-12F5OMXS	8-12F5OMXSS	350
12	1/2	1 5/16-12	3/4-16	41	10	10	45	30	160	8-16 F5OX-S	8-16F5OMXSS	310
14, 15, 16	5/8	7/8-14	7/8-14	27	12	12	43	31	75	10F5OMXS	10F5OMXSS	350
14, 15, 16	5/8	9/16-18	7/8-14	18	13	8	43	34	60	10-6 F5OX-S	10-6F5OMXSS	350
14, 15, 16	5/8	3/4-16	7/8-14	24	12	10	42	31	65	10-8F5OMXS	10-8F5OMXSS	350
14, 15, 16	5/8	1 1/16-12	7/8-14	32	12	12	47	32	132	10-12F5OMXS	10-12F5OMXSS	350
14, 15, 16	5/8	1 5/16-12	7/8-14	41	13	13	48	33	170	10-16 F5OX-S	10-16F5OMXSS	310
18, 20	3/4	1 1/16-12	1 1/16-12	32	16	16	50	35	134	12F5OMXS	12F5OMXSS	350
18, 20	3/4	3/4-16	1 1/16-12	29	16	10	49	38	104	12-8 F5OX-S	12-8F5OMXSS	350
18, 20	3/4	7/8-14	1 1/16-12	27	16	12	48	35	108	12-10F5OMXS	12-10F5OMXSS	350
18, 20	3/4	1 3/16-12	1 1/16-12	35	16	16	50	35	170	12-14 F5OX-S	12-14F5OMXSS	310
18, 20	3/4	1 5/16-12	1 1/16-12	38	16	16	51	35	197	12-16F5OMXS	12-16F5OMXSS	310
18, 20	3/4	1 5/8-12	1 1/16-12	48	16	16	53	38	230	12-20 F5OX-S	12-20F5OMXSS	280
22	7/8	1 3/16-12	1 3/16-12	35	18	18	51	36	174	14 F5OX-S	14F5OMXSS	280
22	7/8	1 5/16-12	1 3/16-12	38	18	22	51	36	223	14-16 F5OX-S	14-16F5OMXSS	280
25	1	1 5/16-12	1 5/16-12	38	22	22	52	37	203	16F5OMXS	16F5OMXSS	280
25	1	3/4-16	1 5/16-12	35	22	10	45	34	160	16-8 F5OX-S	16-8F5OMXSS	280

Continued on page K30

F5OMX Male stud connector

Triple-Lok® 37° Flare end / Male UN/UNF thread – O-ring (ISO 11926)
SAE 070120 MS51525

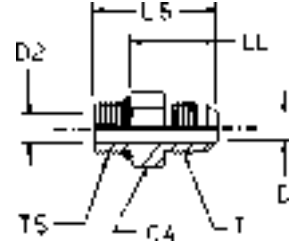

Tube O.D. mm	Tube O.D. in.	Thread UN/UNF-2A T5	Thread UN/UNF-2A T	C4 mm	D mm	D2 mm	L5 mm	LL mm	Weight (steel) g/1 piece	Triple-Lok® Steel	Triple-Lok® Stainless Steel	PN (bar)
25	1	7/8-14	1 5/16-12	35	22	12	53	40	183	16-10 F5OX-S	16-10F5OMXSS	280
25	1	1 1/16-12	1 5/16-12	36	22	16	52	37	204	16-12F5OMXS	16-12F5OMXSS	280
25	1	1 3/16-12	1 5/16-12	35	22	18	52	37	198	16-14 F5OX-S	16-14F5OMXSS	280
25	1	1 5/8-12	1 5/16-12	48	22	28	54	39	270	16-20 F5OX-S	16-20F5OMXSS	280
25	1	1 7/8-12	1 5/16-12	55	22	22	56	41	310	16-24 F5OX-S	16-24F5OMXSS	210
28, 30, 32	1 1/4	1 5/8-12	1 5/8-12	50	28	28	55	40	274	20F5OMXS	20F5OMXSS	280
28, 30, 32	1 1/4	1 1/16-12	1 5/8-12	43	28	16	58	43	250	20-12 F5OX-S	20-12F5OMXSS	280
28, 30, 32	1 1/4	1 5/16-12	1 5/8-12	43	28	22	59	44	280	20-16 F5OX-S	20-16F5OMXSS	280
35, 38	1 1/2	1 7/8-12	1 7/8-12	55	33	33	60	45	355	24F5OMXS	24F5OMXSS	210
35, 38	1 1/2	1 5/8-12	1 7/8-12	51	33	28	64	49	340	24-20 F5OX-S	24-20F5OMXSS	210
35, 38	1 1/2	2 1/2-12	1 7/8-12	70	34	34	64	49	400	24-32 F5OX-S		140
	2	2 1/2-12	2 1/2-12	70	45	45	71	56	650	32 F5OX-S		140
	2	1 7/8-12	2 1/2-12	68	45	34	75	60	600	32-24 F5OX-S		140

Triple-Lok® is delivered with NBR elastomeric seals as standard. For more details on other seal materials see page K93
Order codes shown are part of our current manufacturing programme.
Imperial and metric parts may vary in hexagon dimensions.

$$\frac{\text{PN (bar)}}{10} = \text{PN (MPa)}$$

Pressure ratings – PN shown, apply to Steel and Stainless Steel versions of the product.

FF5OMX Extended male stud connector

Triple-Lok® 37° Flare end / Male UN/UNF thread – O-ring (ISO 11926)
SAE 070122 MS51526

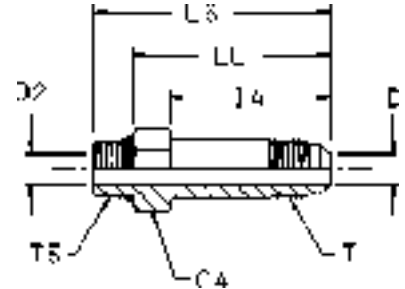

Tube O.D.		Thread UN/UNF-2A T5	Thread UN/UNF-2A T	C4 mm	D mm	D2 mm	14 mm	L6 mm	LL mm	Weight (steel) g/1 piece	Triple-Lok® Steel	Triple-Lok® Stainless Steel	PN (bar)
mm	in.												
6	1/4	7/16-20	7/16-20	14	4	4	35	53	44	33	4 FF5OX-S	4 FF5OX-SS	500
10	3/8	9/16-18	9/16-18	17	8	8	40	59	49	53	6 FF5OX-S	6 FF5OX-SS	420
12	1/2	3/4-16	3/4-16	22	10	10	48	69	57	104	8 FF5OX-S	8 FF5OX-SS	420
14, 15, 16	5/8	7/8-14	7/8-14	25	12	12	53	77	64	151	10 FF5OX-S	10 FF5OX-SS	350
18, 20	3/4	1 1/16-12	1 1/16-12	32	16	16	64	92	77	277	12 FF5OX-S	12 FF5OX-SS	350
18, 20	3/4	7/8-14	1 1/16-12	27	16	12	64	89	76	236	12-10FF5OMXS		350
25	1	1 5/16-12	1 5/16-12	38	21	21	72	101	86	458	16 FF5OX-S	16 FF5OX-SS	280
28, 30, 32	1 1/4	1 5/8-12	1 5/8-12	48	27	27	88	119	104	862	20 FF5OX-S	20 FF5OX-SS	280

Triple-Lok® is delivered with NBR elastomeric seals as standard. For more details on other seal materials see page K93
Order codes shown are part of our current manufacturing programme.
Imperial and metric parts may vary in hexagon dimensions.

$$\frac{\text{PN (bar)}}{10} = \text{PN (MPa)}$$

Pressure ratings – PN shown, apply to Steel and Stainless Steel versions of the product.

K

F42EDMX Male stud connector

Triple-Lok® 37° Flare end / Male BSPP thread – ED seal (ISO 1179)

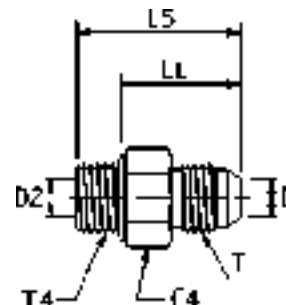

Tube O.D.		Thread BSPP T4	Thread UN/UNF-2A T	C4 mm	D mm	D2 mm	L5 mm	LL mm	Weight (steel) g/1 piece	Triple-Lok® Steel	Triple-Lok® Stainless Steel	PN (bar)
mm	in.											
6	1/4	1/8-28	7/16-20	14	4	4	30	22	20	4F42EDMXS	4F42EDMXSS	500
6	1/4	1/4-19	7/16-20	19	4	4	35	23	34	4-4F42EDMXS	4-4F42EDMXSS	420
6	1/4	3/8-19	7/16-20	22	4	4	36	24	47	4-6F42EDMXS	4-6F42EDMXSS	420
6	1/4	1/2-14	7/16-20	27	4	4	39	25	99	4-8F42EDMXS	4-8F42EDMXSS	350
6	1/4	3/4-14	7/16-20	32	4	18	43	27	88	4-12F42EDMXS	4-12F42EDMXSS	350
8	5/16	1/8-28	1/2-20	14	6	4	30	22	20	5F42EDMXS	5F42EDMXSS	420
8	5/16	1/4-19	1/2-20	19	6	6	35	23	30	5-4F42EDMXS	5-4F42EDMXSS	420
8	5/16	3/8-19	1/2-20	22	6	6	36	24	47	5-6F42EDMXS	5-6F42EDMXSS	420
10	3/8	1/4-19	9/16-18	19	8	6	35	23	28	6F42EDMXS	6F42EDMXSS	420
10	3/8	1/8-28	9/16-18	16	8	4	31	23	27	6-2F42EDMXS	6-2F42EDMXSS	420
10	3/8	3/8-19	9/16-18	22	8	8	36	24	40	6-6F42EDMXS	6-6F42EDMXSS	420
10	3/8	1/2-14	9/16-18	27	8	8	40	25	95	6-8F42EDMXS	6-8F42EDMXSS	350
10	3/8	3/4-14	9/16-18	22	8	18	42	26	100	6-12F42EDMXS	6-12F42EDMXSS	350
12	1/2	3/8-19	3/4-16	22	10	10	39	27	50	8F42EDMXS	8F42EDMXSS	420
12	1/2	1/4-19	3/4-16	19	10	6	39	27	40	8-4F42EDMXS	8-4F42EDMXSS	420
12	1/2	1/2-14	3/4-16	27	10	10	42	28	100	8-8F42EDMXS	8-8F42EDMXSS	350
12	1/2	3/4-14	3/4-16	32	10	10	46	30	100	8-12F42EDMXS	8-12F42EDMXSS	350
12	1/2	1-11	3/4-16	41	10	23	53	35	150	8-16F42EDMXS	8-16F42EDMXSS	280
14, 15,16	5/8	1/2-14	7/8-14	27	12	12	45	31	103	10F42EDMXS	10F42EDMXSS	350
14, 15,16	5/8	1/4-19	7/8-14	24	13	6	41	29	110	10-4F42EDMXS	10-4F42EDMXSS	350
14, 15,16	5/8	3/8-19	7/8-14	24	12	9	43	31	65	10-6F42EDMXS	10-6F42EDMXSS	350
14, 15,16	5/8	3/4-14	7/8-14	32	12	12	48	32	160	10-12F42EDMXS	10-12F42EDMXSS	350
14, 15,16	5/8	1-11	7/8-14	41	13	13	51	33	205	10-16F42EDMXS	10-16F42EDMXSS	280
18, 20	3/4	3/4-14	1 1/16-12	32	16	16	51	35	165	12F42EDMXS	12F42EDMXSS	350
18, 20	3/4	3/8-19	1 1/16-12	27	16	9	50	38	105	12-6F42EDMXS	12-6F42EDMXSS	350
18, 20	3/4	1/2-14	1 1/16-12	27	16	14	49	35	118	12-8F42EDMXS	12-8F42EDMXSS	350
18, 20	3/4	1-11	1 1/16-12	41	16	16	54	35	292	12-16F42EDMXS	12-16F42EDMXSS	280
18, 20	3/4	1 1/4-11	1 1/16-12	50	16	30	62	42	220	12-20F42EDMXS	12-20F42EDMXSS	280
22	7/8	3/4-14	1 3/16-12	32	18	18	51	35	173	14F42EDMXS	14F42EDMXSS	280
25	1	1-11	1 5/16-12	41	22	22	55	37	262	16F42EDMXS	16F42EDMXSS	280
25	1	1/2-14	1 5/16-12	41	22	14	51	37	145	16-8F42EDMXS	16-8F42EDMXSS	280
25	1	3/4-14	1 5/16-12	36	22	18	53	37	217	16-12F42EDMXS	16-12F42EDMXSS	280
25	1	1 1/4-11	1 5/16-12	50	22	22	59	39	386	16-20F42EDMXS	16-20F42EDMXSS	280
28, 30, 32	1 1/4	1 1/4-11	1 5/8-12	50	28	28	60	40	375	20F42EDMXS	20F42EDMXSS	280
28, 30, 32	1 1/4	3/4-14	1 5/8-12	50	28	18	56	40	220	20-12F42EDMXS	20-12F42EDMXSS	280
28, 30, 32	1 1/4	1-11	1 5/8-12	46	28	23	62	44	255	20-16F42EDMXS	20-16F42EDMXSS	280
28, 30, 32	1 1/4	1 1/2-11	1 5/8-12	55	28	28	64	42	420	20-24F42EDMXS	20-24F42EDMXSS	210
35, 38	1 1/2	1 1/2-11	1 7/8-12	55	33	33	67	45	480	24F42EDMXS	24F42EDMXSS	210
35, 38	1 1/2	1-11	1 7/8-12	50	33	23	63	45	390	24-16F42EDMXS	24-16F42EDMXSS	210
35, 38	1 1/2	1 1/4-11	1 7/8-12	50	33	30	62	42	420	24-20F42EDMXS	24-20F42EDMXSS	210
42		1 1/2-11	2 1/4-12	60	39	36	71	49	746	28-24F42EDMXS	28-24F42EDMXSS	140

Triple-Lok® is delivered with NBR elastomeric seals as standard. For more details on other seal materials see page K93

Order codes shown are part of our current manufacturing programme. Imperial and metric parts may vary in hexagon dimensions.

$$\frac{\text{PN (bar)}}{10} = \text{PN (MPa)}$$

Pressure ratings – PN shown, apply to Steel and Stainless Steel versions of the product.

F4OMX Male stud connector

Triple-Lok® 37° Flare end / Male BSPP thread – O-ring + retaining ring (ISO 1179)

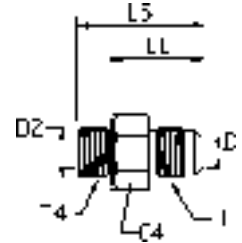

Tube O.D.		Thread BSPP T4	Thread UN/UNF-2A T	C4 mm	D mm	D2 mm	L5 mm	LL mm	Weight (steel) g/1 piece	Triple-Lok® Steel	Triple-Lok® Stainless Steel	PN (bar)
mm	in.											
6	1/4	1/8-28	7/16-20	16	4	4	28	22	20	4F4OMXS	4F4OMXSS	350
6	1/4	1/4-19	7/16-20	19	4	4	32	23	34	4-4F4OMXS	4-4F4OMXSS	350
6	1/4	3/8-19	7/16-20	22	4	4	33	24	47	4-6F4OMXS	4-6F4OMXSS	350
6	1/4	1/2-14	7/16-20	30	4	4	39	26	99	4-8F4OMXS	4-8F4OMXSS	350
8	5/16	1/8-28	1/2-20	16	6	4	28	22	25	5F4OMXS	5F4OMXSS	350
8	5/16	1/4-19	1/2-20	19	6	6	32	23	30	5-4F4OMXS	5-4F4OMXSS	350
8	5/16	3/8-19	1/2-20	22	6	6	33	24	47	5-6F4OMXS	5-6F4OMXSS	350
10	3/8	1/4-19	9/16-18	19	8	6	33	23	28	6F4OMXS	6F4OMXSS	350
10	3/8	1/8-28	9/16-18	16	8	4	29	23	27	6-2F4OMXS	6-2F4OMXSS	350
10	3/8	3/8-19	9/16-18	22	8	8	33	24	40	6-6F4OMXS	6-6F4OMXSS	350
10	3/8	1/2-14	9/16-18	30	8	8	38	25	25	6-8F4OMXS	6-8F4OMXSS	350
10	3/8	3/4-14	9/16-18	36	8	8	40	25	100	6-12F4OMXS	6-12F4OMXSS	280
12	1/2	3/8-19	3/4-16	22	10	10	36	27	50	8F4OMXS	8F4OMXSS	350
12	1/2	1/4-19	3/4-16	19	10	6	35	26	40	8-4F4OMXS	8-4F4OMXSS	350
12	1/2	1/2-14	3/4-16	30	10	10	41	29	100	8-8F4OMXS	8-8F4OMXSS	350
12	1/2	3/4-14	3/4-16	36	10	10	42	30	100	8-12F4OMXS	8-12F4OMXSS	280
12	1/2	1-11	3/4-16	46	10	10	47	29	150	8-16F4OMXS	8-16F4OMXSS	280
14, 15,16	5/8	1/2-14	7/8-14	30	12	12	43	31	103	10F4OMXS	10F4OMXSS	350
14, 15,16	5/8	1/4-19	7/8-14	24	12	6	39	28	110	10-4F4OMXS	10-4F4OMXSS	350
14, 15,16	5/8	3/8-19	7/8-14	24	12	9	39	30	65	10-6F4OMXS	10-6F4OMXSS	350
14, 15,16	5/8	3/4-14	7/8-14	36	12	12	45	32	160	10-12F4OMXS	10-12F4OMXSS	280
18, 20	3/4	3/4-14	1 1/16-12	36	16	16	48	35	165	12F4OMXS	12F4OMXSS	280
18, 20	3/4	3/8-19	1 1/16-12	27	16	9	44	34	97	12-6F4OMXS	12-6F4OMXSS	350
18, 20	3/4	1/2-14	1 1/16-12	30	16	12	47	34	118	12-8F4OMXS	12-8F4OMXSS	350
18, 20	3/4	1-11	1 1/16-12	46	16	16	53	37	292	12-16F4OMXS	12-16F4OMXSS	280
18, 20	3/4	1 1/4-11	1 1/16-12	50	16	16	53	34	220	12-20F4OMXS	12-20F4OMXSS	250
25	1	1-11	1 5/16-12	46	22	22	54	38	262	16F4OMXS	16F4OMXSS	280
25	1	1/2-14	1 5/16-12	36	22	12	49	34	145	16-8F4OMXS	16-8F4OMXSS	280
25	1	3/4-14	1 5/16-12	36	22	16	49	36	173	16-12F4OMXS	16-12F4OMXSS	280
25	1	1 1/4-11	1 5/16-12	50	22	22	55	39	386	16-20F4OMXS	16-20F4OMXSS	250
28, 30, 32	1 1/4	1 1/4-11	1 5/8-12	50	28	28	56	40	325	20F4OMXS	20F4OMXSS	250
28, 30, 32	1 1/4	3/4-14	1 5/8-12	46	28	16	51	36	220	20-12F4OMXS	20-12F4OMXSS	280
28, 30, 32	1 1/4	1-11	1 5/8-12	46	28	22	55	39	330	20-16F4OMXS	20-16F4OMXSS	280
28, 30, 32	1 1/4	1 1/2-11	1 5/8-12	55	28	28	57	41	480	20-24F4OMXS	20-24F4OMXSS	210
35, 38	1 1/2	1 1/2-11	1 7/8-12	55	33	33	61	45	480	24F4OMXS	24F4OMXSS	210
35, 38	1 1/2	1 1/4-11	1 7/8-12	50	33	28	60	44	420	24-20F4OMXS	24-20F4OMXSS	210
42	1 1/2	1 1/2-11	2 1/4	60	39	33	68	52	740	28-24F4OMXS	28-24F4OMXSS	140

Triple-Lok® is delivered with NBR elastomeric seals as standard. For more details on other seal materials see page K93
Order codes shown are part of our current manufacturing programme.
Imperial and metric parts may vary in hexagon dimensions.

$$\frac{\text{PN (bar)}}{10} = \text{PN (MPa)}$$

Pressure ratings – PN shown, apply to Steel and Stainless Steel versions of the product.

F82EDMX Male stud connector

Triple-Lok® 37° Flare end / Male metric thread – ED seal (ISO 9974)

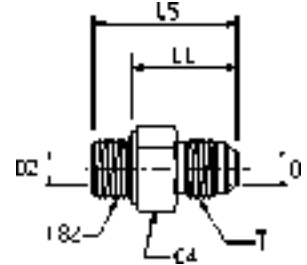

Tube O.D. mm	Tube O.D. in.	Thread Metric T82	Thread UN/UNF-2A T	C4 mm	D mm	D2 mm	L5 mm	LL mm	Weight (steel) g/1 piece	Triple-Lok® Steel	Triple-Lok® Stainless Steel	PN (bar)
6	1/4	M10 x 1.0	7/16-20	14	4	4	30	22	19	4M10F82EDMXS	4M10F82EDMXSS	500
6	1/4	M12 x 1.5	7/16-20	17	4	4	34	22	30	4M12F82EDMXS	4M12F82EDMXSS	420
8	5/16	M10 x 1.0	1/2-20	14	6	4	30	22	17	5M10F82EDMXS	5M10F82EDMXSS	420
8	5/16	M12 x 1.5	1/2-20	17	6	5	34	22	28	5M12F82EDMXS	5M12F82EDMXSS	420
8	5/16	M14 x 1.5	1/2-20	19	6	7	36	24	35	5M14F82EDMXS	5M14F82EDMXSS	420
10	3/8	M12 x 1.5	9/16-18	17	8	5	35	23	33	6M12F82EDMXS	6M12F82EDMXSS	420
10	3/8	M14 x 1.5	9/16-18	19	8	7	35	23	38	6M14F82EDMXS	6M14F82EDMXSS	420
10	3/8	M16 x 1.5	9/16-18	22	8	8	36	24	53	6M16F82EDMXS	6M16F82EDMXSS	420
10	3/8	M18 x 1.5	9/16-18	24	8	8	36	24	60	6M18F82EDMXS	6M18F82EDMXSS	350
10	3/8	M22 x 1.5	9/16-18	27	8	8	39	25	68	6M22F82EDMXS	6M22F82EDMXSS	350
12	1/2	M14 x 1.5	3/4-16	19	10	7	39	27	41	8M14F82EDMXS	8M14F82EDMXSS	420
12	1/2	M16 x 1.5	3/4-16	22	10	9	39	27	57	8M16F82EDMXS	8M16F82EDMXSS	420
12	1/2	M18 x 1.5	3/4-16	24	10	10	39	27	71	8M18F82EDMXS	8M18F82EDMXSS	350
12	1/2	M22 x 1.5	3/4-16	27	10	10	42	28	70	8M22F82EDMXS	8M22F82EDMXSS	350
14, 15, 16	5/8	M18 x 1.5	7/8-14	24	12	11	43	31	104	10M18F82EDMXS	10M18F82EDMXSS	350
14, 15, 16	5/8	M20 x 1.5	7/8-14	27	11	11	46	32	90	10M20F82EDMXS	10M20F82EDMXSS	350
14, 15, 16	5/8	M22 x 1.5	7/8-14	27	12	12	45	31	161	10M22F82EDMXS	10M22F82EDMXSS	350
18, 20	3/4	M18 x 1.5	1 1/16-12	27	16	11	46	34	85	12M18F82EDMXS	12M18F82EDMXSS	350
18, 20	3/4	M22 x 1.5	1 1/16-12	27	16	14	49	35	273	12M22F82EDMXS	12M22F82EDMXSS	350
18, 20	3/4	M26 x 1.5	1 1/16-12	32	16	16	51	35	135	12M26F82EDMXS	12M26F82EDMXSS	350
18, 20	3/4	M27 x 2.0	1 1/16-12	32	16	16	51	35	431	12M27F82EDMXS	12M27F82EDMXSS	350
25	1	M26 x 1.5	1 5/16-12	41	22	18	55	39	350	16M26F82EDMXS	16M26F82EDMXSS	280
25	1	M27 x 2.0	1 5/16-12	36	16	16	53	37	360	16M27F82EDMXS	16M27F82EDMXSS	280
25	1	M33 x 2.0	1 5/16-12	41	22	22	55	37	431	16M33F82EDMXS	16M33F82EDMXSS	280
28, 30, 32	1 1/4	M42 x 2.0	1 5/8-12	50	28	28	60	40	431	20M42F82EDMXS	20M42F82EDMXSS	280
35, 38	1 1/2	M48 x 2.0	1 7/8-12	55	33	33	67	45	580	24M48F82EDMXS	24M48F82EDMXSS	210

Triple-Lok® is delivered with NBR elastomeric seals as standard. For more details on other seal materials see page K93

Order codes shown are part of our current manufacturing programme.

Imperial and metric parts may vary in hexagon dimensions.

$$\frac{\text{PN (bar)}}{10} = \text{PN (MPa)}$$

Pressure ratings – PN shown, apply to Steel and Stainless Steel versions of the product.

F8OMX Male stud connector

Triple-Lok® 37° Flare end / Male metric thread – O-ring + retainer ring

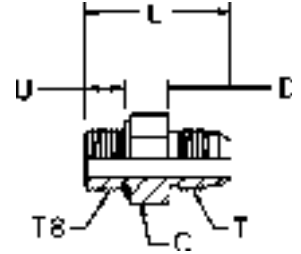

Tube O.D.		Thread Metric T8	Thread UN/UNF-2A T	L mm	D mm	C mm	U mm	Weight (steel) g/1 piece	Triple-Lok® Steel	Triple-Lok® Stainless Steel	PN (bar)
mm	in.										
6	1/4	M10 x 1.0	7/16-20	30	14	14	9	25	4M10F8OMXS	4M10F8OMXSS	350
6	1/4	M12 x 1.5	7/16-20	33	14	17	11	35	4M12F8OMXS	4M12F8OMXSS	420
8	5/16	M10 x 1.0	1/2-20	30	14	14	9	25	5M10F8OMXS	5M10F8OMXSS	350
8	5/16	M12 x 1.5	1/2-20	33	14	19	11	35	5M12F8OMXS	5M12F8OMXSS	420
8	5/16	M14 x 1.5	1/2-20	34	14	19	11	35	5M14F8OMXS	5M14F8OMXSS	350
10	3/8	M12 x 1.5	9/16-18	34	14	17	11	35	6M12F8OMXS	6M12F8OMXSS	420
10	3/8	M14 x 1.5	9/16-18	34	14	19	11	35	6M14F8OMXS	6M14F8OMXSS	350
10	3/8	M16 x 1.5	9/16-18	36	14	22	12	51	6M16F8OMXS	6M16F8OMXSS	350
10	3/8	M18 x 1.5	9/16-18	37	14	24	13	60	6M18F8OMXS	6M18F8OMXSS	250
12	1/2	M14 x 1.5	3/4-16	36	17	19	11	38	8M14F8OMXS	8M14F8OMXSS	350
12	1/2	M16 x 1.5	3/4-16	38	17	22	12	55	8M16F8OMXS	8M16F8OMXSS	350
12	1/2	M18 x 1.5	3/4-16	39	17	24	13	66	8M18F8OMXS	8M18F8OMXSS	250
12	1/2	M22 x 1.5	3/4-16	41	17	27	13	70	8M22F8OMXS	8M22F8OMXSS	250
14, 15,16	5/8	M18 x 1.5	7/8-14	43	19	24	13	71	10M18F8OMXS	10M18F8OMXSS	250
14, 15,16	5/8	M22 x 1.5	7/8-14	45	19	27	14	90	10M20F8OMXS	10M20F8OMXSS	250
14, 15,16	5/8	M22 x 1.5	7/8-14	44	19	27	13	98	10M22F8OMXS	10M22F8OMXSS	250
18, 20	3/4	M18 x 1.5	1 1/16-12	51	22	27	13	85	12M18F8OMXS	12M18F8OMXSS	250
18, 20	3/4	M22 x 1.5	1 1/16-12	48	22	27	13	104	12M22F8OMXS	12M22F8OMXSS	250
18, 20	3/4	M24 x 1.5	1 1/16-12	45	22	30	12	120	12M24F8OMXS	12M24F8OMXSS	210
18, 20	3/4	M27 x 2.0	1 1/16-12	51	22	32	16	154	12M27F8OMXS	12M27F8OMXSS	210
25	1	M22 x 1.5	1 5/16-12	48	23	36	13	180	16M22F8OMXS	16M22F8OMXSS	250
25	1	M26 x 1.5	1 5/16-12	52	23	36	17	202	16M26F8OMXS	16M26F8OMXSS	210
25	1	M27 x 2.0	1 5/16-12	51	23	36	16	202	16M27F8OMXS	16M27F8OMXSS	210
25	1	M33 x 2.0	1 5/16-12	53	23	41	16	267	16M33F8OMXS	16M33F8OMXSS	210
28, 30, 32	1 1/4	M42 x 2.0	1 5/8-12	55	24	50	16	427	20M42F8OMXS	20M42F8OMXSS	210
35, 38	1 1/2	M48 x 2.0	1 7/8-12	59	28	55	18	545	24M48F8OMXS	24M48F8OMXSS	140

Triple-Lok® is delivered with NBR elastomeric seals as standard. For more details on other seal materials see page K93

Order codes shown are part of our current manufacturing programme.

Imperial and metric parts may vary in hexagon dimensions.

$$\frac{\text{PN (bar)}}{10} = \text{PN (MPa)}$$

Pressure ratings – PN shown, apply to Steel and Stainless Steel versions of the product.

FMTX Male stud connector

Triple-Lok® 37° Flare end / Male NPTF* thread (SAE 476)
SAE 070102 MS51500

*Stainless Steel = NPT to prevent galling

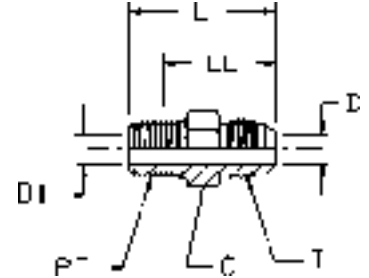

Tube O.D.		Thread NPT/NPTF PT	Thread UN/UNF-2A T	C mm	D mm	D1 mm	L mm	LL mm	Weight (steel) g/1 piece	Triple-Lok®		PN (bar)
mm	in.									Steel	Stainless Steel	
5	1/8	1/8-27	5/16-24	11	2	5	28	22	10	2 FTX-S		420
5	3/16	1/8-27	3/8-24	11	3	5	29	23	12	3 FTX-S		420
6	1/4	1/8-27	7/16-20	13	4	4	31	23	14	4FMTXS	4FMTXS	420
6	1/4	1/4-18	7/16-20	14	4	4	36	24	26	4-4FMTXS	4-4FMTXS	420
6	1/4	3/8-18	7/16-20	19	4	10	37	28	26	4-6 FTX-S	4-6FMTXS	420
6	1/4	1/2-14	7/16-20	22	4	14	43	31	26	4-8 FTX-S	4-8FMTXS	420
8	5/16	1/8-27	1/2-20	14	6	5	31	23	17	5FMTXS	5FMTXS	420
8	5/16	1/4-18	1/2-20	14	6	6	36	24	25	5-4FMTXS	5-4FMTXS	420
8	5/16	3/8-18	1/2-20	19	6	6	36	26	30	5-6FMTXS	5-6FMTXS	420
10	3/8	1/4-16	9/16-18	16	8	8	36	25	25	6FMTXS	6FMTXS	420
10	3/8	1/8-27	9/16-18	16	8	5	32	26	21	6-2 FTX-S	6-2FMTXS	420
10	3/8	3/8-18	9/16-18	19	8	8	36	25	39	6-6FMTXS	6-6FMTXS	420
10	3/8	1/2-14	9/16-18	22	8	8	43	28	47	6-8FMTXS	6-8FMTXS	420
12	1/2	3/8-18	3/4-16	19	10	10	39	27	45	8FMTXS	8FMTXS	420
12	1/2	1/4-16	3/4-16	19	10	7	39	27	42	8-4FMTXS	8-4FMTXS	420
12	1/2	1/2-14	3/4-16	22	10	10	46	30	74	8-8FMTXS	8-8FMTXS	420
12	1/2	3/4-14	3/4-16	27	10	10	47	31	121	8-12FMTXS	8-12FMTXS	380
14, 15, 16	5/8	1/2-14	7/8-14	24	12	12	48	33	77	10FMTXS	10FMTXS	350
14, 15, 16	5/8	3/8-18	7/8-14	24	12	10	43	31	63	10-6FMTXS	10-6FMTXS	350
14, 15, 16	5/8	3/4-14	7/8-14	27	12	12	50	34	122	10-12FMTXS	10-12FMTXS	350
18, 20	3/4	3/4-14	1 1/16-12	27	16	16	52	37	123	12FMTXS	12FMTXS	350
18, 20	3/4	3/8-18	1 1/16-12	29	16	10	48	39	90	12-6 FTX-S	12-6FMTXS	350
18, 20	3/4	1/2-14	1 1/16-12	27	16	14	52	37	103	12-8FMTXS	12-8FMTXS	350
18, 20	3/4	1-11 1/2	1 1/16-12	36	16	16	57	38	176	12-16FMTXS	12-16FMTXS	310
22	7/8	3/4-14	1 3/16-12	32	18	18	53	41	137	14 FTX-S	14FMTXS	280
25	1	1-11 1/2	1 5/16-12	36	22	22	58	39	189	16FMTXS	16FMTXS	280
25	1	1/2-14	1 5/16-12	35	22	14	54	42	110	16-8 FTX-S	16-8FMTXS	280
25	1	3/4-14	1 5/16-12	36	22	18	54	38	149	16-12FMTXS	16-12FMTXS	280
28, 30, 32	1 1/4	1 1/4-11 1/2	1 5/8-12	46	28	28	62	42	315	20FMTXS	20FMTXS	210
28, 30, 32	1 1/4	1-11 1/2	1 5/8-12	46	28	24	61	42	248	20-16FMTXS	20-16FMTXS	280
35, 38	1 1/2	1 1/2-11 1/2	1 7/8-12	50	33	33	68	48	430	24FMTXS	24FMTXS	210
35, 38	1 1/2	1-11 1/2	1 7/8-12	50	33	24	67	52	310	24-16 FTX-S	24-16FMTXS	210
35, 38	1 1/2	1 1/4-11 1/2	1 7/8-12	50	33	32	67	47	359	24-20FMTXS	24-20FMTXS	210
35, 38	1 1/2	2-11 1/2	1 7/8-12	68	33	33	73	57	720	24-32 FTX-S	24-32FMTXS	140
	2	2-11/12	2 1/2-12	67	45	49	79	64	858	32 FTX-S	32FMTXS	140
	2	1 1/2-11 1/2	2 1/2-12	68	45	38	78	63	720	32-24 FTX-S	32-24FMTXS	140

Order codes shown are part of our current manufacturing programme.
Imperial and metric parts may vary in hexagon dimensions.

$$\frac{PN \text{ (bar)}}{10} = PN \text{ (MPa)}$$

Pressure ratings – PN shown, apply to Steel and Stainless Steel versions of the product.
For Brass parts reduce pressures by 35%

F3MX Male stud connector

Triple-Lok® 37° Flare end / Male BSPT thread (ISO 7)

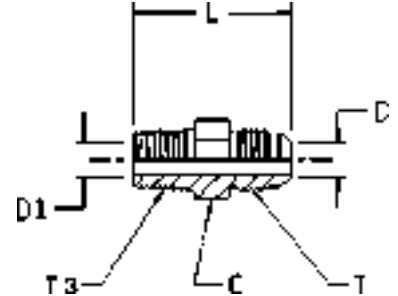

Tube O.D.		Thread BSPT T3	Thread UN/UNF-2A T	C mm	D mm	D1 mm	L mm	Weight (steel) g/1 piece	Triple-Lok® Steel	Triple-Lok® Stainless Steel	PN (bar)
mm	in.										
6	1/4	1/8-28	7/16-20	13	4	4	31	13	4F3MXS	4F3MXSS	315
6	1/4	1/4-19	7/16-20	14	4	4	36	25	4-4F3MXS	4-4F3MXSS	315
8	5/16	1/8-28	1/2-20	14	6	5	31	17	5F3MXS	5F3MXSS	315
8	5/16	1/4-19	1/2-20	14	6	6	36	24	5-4F3MXS	5-4F3MXSS	315
10	3/8	1/4-19	9/16-18	16	8	8	36	25	6F3MXS	6F3MXSS	315
10	3/8	3/8-19	9/16-18	19	8	8	36	37	6-6F3MXS	6-6F3MXSS	315
10	3/8	1/2-14	9/16-18	22	8	8	43	45	6-8F3MXS	6-8F3MXSS	315
12	1/2	3/8-19	3/4-16	19	10	10	39	43	8F3MXS	8F3MXSS	315
12	1/2	1/4-19	3/4-16	19	10	7	39	41	8-4F3MXS	8-4F3MXSS	315
12	1/2	1/2-14	3/4-16	22	10	10	46	71	8-8F3MXS	8-8F3MXSS	315
14, 15, 16	5/8	1/2-14	7/8-14	24	12	12	48	74	10F3MXS	10F3MXSS	315
14, 15, 16	5/8	3/8-19	7/8-14	24	12	10	43	61	10-6F3MXS	10-6F3MXSS	315
14, 15, 16	5/8	3/4-14	7/8-14	27	12	12	50	117	10-12F3MXS	10-12F3MXSS	160
18, 20	3/4	3/4-14	1 1/16-12	27	16	16	52	119	12F3MXS	12F3MXSS	160
18, 20	3/4	1/2-14	1 1/16-12	27	16	14	52	100	12-8F3MXS	12-8F3MXSS	315
18, 20	3/4	1-11	1 1/16-12	36	16	16	57	214	12-16F3MXS	12-16F3MXSS	160
25	1	1-11	1 5/16-12	36	22	22	58	185	16F3MXS	16F3MXSS	160
25	1	3/4-14	1 5/16-12	36	22	18	54	146	16-12F3MXS	16-12F3MXSS	160
28, 30, 32	1 1/4	1 1/4-11	1 5/8-12	46	28	28	62	309	20F3MXS	20F3MXSS	160
28, 30, 32	1 1/4	1-11	1 5/8-12	46	28	24	61	243	20-16F3MXS	20-16F3MXSS	160
35, 38	1 1/2	1 1/2-11	1 7/8-12	50	33	33	68	421	24F3MXS	24F3MXSS	160
35, 38	1 1/2	1 1/4-11	1 7/8-12	50	33	32	67	352	24-20F3MXS	24-20F3MXSS	160

Order codes shown are part of our current manufacturing programme.
Imperial and metric parts may vary in hexagon dimensions.

$$\frac{\text{PN (bar)}}{10} = \text{PN (MPa)}$$

Pressure ratings – PN shown, apply to Steel and Stainless Steel versions of the product.

F687OMX Swivel male stud

Triple-Lok® 37° Flare female swivel end / Male metric thread – O-ring (ISO 6149)

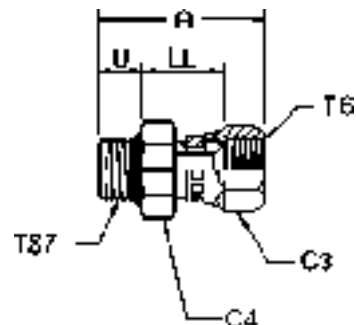

Tube O.D.		Thread Metric T87	Thread UN/UNF-2B T6	A mm	LL mm	U mm	C3 mm	C4 mm	Weight (steel) g/1 piece	Triple-Lok® Steel	Triple-Lok® Stainless Steel	PN (bar)
mm	in.											
6	1/4	M10 x 1.0	7/16-20	34	15	9	16	14	25	4M10F687OMXS	4M10F687OMXSS	500
6	1/4	M12 x 1.5	7/16-20	38	15	11	16	17	30	4M12F687OMXS	4M12F687OMXSS	420
8	5/16	M10 x 1.5	1/2-20	39	18	9	17	17	40	5M10F687OMXS	5M10F687OMXSS	420
8	5/16	M12 x 1.5	1/2-20	44	17	11	17	17	64	5M12F687OMXS	5M12F687OMXSS	420
10	3/8	M14 x 1.5	9/16-18	45	18	11	19	19	65	6M14F687OMXS	6M14F687OMXSS	350
10	3/8	M16 x 1.6	9/16-18	46	19	12	19	22	75	6M16F687OMXS	6M16F687OMXSS	350
12	1/2	M16 x 1.7	3/4-16	46	21	12	22	22	80	8M16F687OMXS	8M16F687OMXSS	350
12	1/2	M18 x 1.8	3/4-16	47	21	13	22	24	90	8M18F687OMXS	8M18F687OMXSS	350
14, 15, 16	5/8	M18 x 1.5	7/8-14	47	23	13	27	24	108	10M18F687OMXS	10M18F687OMXSS	350
14, 15, 16	5/8	M22 x 1.5	7/8-14	49	23	13	27	27	115	10M22F687OMXS	10M22F687OMXSS	350
18, 20	3/4	M22 x 1.5	1 1/16-12	53	25	13	32	27	183	12M22F687OMXS	12M22F687OMXSS	350
18, 20	3/4	M27 x 2.0	1 1/16-12	54	24	16	32	32	197	12M27F687OMXS	12M27F687OMXSS	350
25	1	M27 x 2.0	1 5/16-12	56	25	16	38	32	230	16M27F687OMXS	16M27F687OMXSS	250
25	1	M33 x 2.0	1 5/16-12	58	27	16	38	41	250	16M33F687OMXS	16M33F687OMXSS	250
28, 30, 32	1 1/4	M42 x 2.0	1 5/8-12	73	31	16	50	50	500	20M42F687OMXS	20M42F687OMXSS	250
35, 38	1 1/2	M48 x 2.0	1 7/8-12	72	33	18	60	55	688	24M48F687OMXS	24M48F687OMXSS	170

Triple-Lok® is delivered with NBR elastomeric seals as standard. For more details on other seal materials see page K93
 Order codes shown are part of our current manufacturing programme.
 Imperial and metric parts may vary in hexagon dimensions.

$$\frac{\text{PN (bar)}}{10} = \text{PN (MPa)}$$

Pressure ratings – PN shown, apply to Steel and Stainless Steel versions of the product.

F65OMX Swivel male stud

Triple-Lok® 37° Flare female swivel end / Male UN/UNF thread – O-ring (ISO 11926)

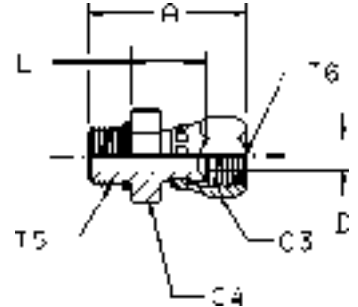

Tube O.D.		Thread UNF T5	Thread UN/UNF-2B T6	A mm	C3 mm	C4 mm	D mm	LL mm	Weight (steel) g/1 piece	Triple-Lok® Steel	PN (bar)
mm	in.										
6	1/4	7/16-20	7/16-20	34	16	14	4	15	27	4F65OMXS	500
8	5/16	1/2-20	1/2-20	34	17	17	6	17	30	5F65OMXS	420
10	3/8	9/16-18	9/16-18	36	19	17	8	16	35	6F65OMXS	350
12	1/2	3/4-16	3/4-16	42	22	22	10	21	64	8F65OMXS	350
14, 15, 16	5/8	7/8-14	7/8-14	47	27	27	12	23	112	10F65OMXS	350
18, 20	3/4	1 1/16-12	1 1/16-12	52	32	32	16	24	183	12F65OMXS	350
25	1	1 5/16-12	1 5/16-12	55	38	41	22	27	234	16F65OMXS	250
28, 30, 32	1 1/4	1 5/8-12	1 5/8-12	63	50	50	28	32	500	20F65OMXS	250

Triple-Lok® is delivered with NBR elastomeric seals as standard. For more details on other seal materials see page K93
 Order codes shown are part of our current manufacturing programme.
 Imperial and metric parts may vary in hexagon dimensions.

$$\frac{\text{PN (bar)}}{10} = \text{PN (MPa)}$$

K

F642EDMX Swivel male stud

Triple-Lok® 37° Flare female swivel end / Male BSPB thread – ED seal (ISO 1179)

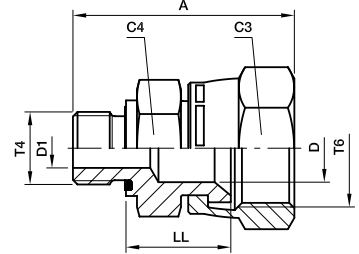

Tube O.D.		Thread BSPB T4	Thread UN/UNF-2B T6	A mm	C3 mm	C4 mm	D mm	D1 mm	LL mm	Weight (steel) g/1 piece	Triple-Lok® Steel	Triple-Lok® Stainless Steel	PN (bar)
mm	in.												
6	1/4	1/8-28	7/16-20	24	16	14	4	4	15	30	4F642EDMXS	4F642EDMXSS	500
6	1/4	1/4-19	7/16-20	29	16	19	4	4	16	30	4-4F642EDMXS	4-4F642EDMXSS	420
8	5/16	1/8-28	1/2-20	25	17	14	6	4	17	28	5F642EDMXS	5F642EDMXSS	420
8	5/16	1/4-19	1/2-20	29	17	19	6	6	18	37	5-4F642EDMXS	5-4F642EDMXSS	420
10	3/8	1/4-19	9/16-18	30	19	19	8	6	18	41	6F642EDMXS	6F642EDMXSS	350
10	3/8	3/8-19	9/16-18	31	19	22	8	8	19	57	6-6F642EDMXS	6-6F642EDMXSS	350
12	1/2	3/8-19	3/4-16	33	22	22	10	9	21	62	8F642EDMXS	8F642EDMXSS	350
12	1/2	1/4-19	3/4-16	33	22	19	10	6	21	60	8-4F642EDMXS	8-4F642EDMXSS	350
12	1/2	1/2-14	3/4-16	34	22	27	10	10	23	75	8-8F642EDMXS	8-8F642EDMXSS	350
14, 15, 16	5/8	1/2-14	7/8-14	37	27	27	12	12	23	127	10F642EDMXS	10F642EDMXSS	350
14, 15, 16	5/8	3/8-19	7/8-14	35	27	22	12	9	23	84	10-6F642EDMXS	10-6F642EDMXSS	350
18, 20	3/4	3/4-14	1 1/16-12	42	32	32	16	16	24	183	12F642EDMXS	12F642EDMXSS	350
18, 20	3/4	1/2-14	1 1/16-12	40	32	27	16	14	25	170	12-8F642EDMXS	12-8F642EDMXSS	350
25	1	1-11	1 5/16-12	45	38	41	22	22	27	296	16F642EDMXS	16F642EDMXSS	250
25	1	3/4-14	1 5/16-12	43	38	36	22	18	27	254	16-12F642EDMXS	16-12F642EDMXSS	250
28, 30, 33	1 1/4	1 1/4-11	1 5/8-12	52	50	50	28	28	32	500	20F642EDMXS	20F642EDMXSS	250
28, 30, 32	1 1/4	1-11	1 5/8-12	54	50	41	28	23	36	440	20-16F642EDMXS	20-16F642EDMXSS	250
35, 38	1 1/2	1 1/2-11	1 7/8-12	58	60	55	33	33	36	739	24F642EDMXS	24F642EDMXSS	170
35, 38	1 1/2	1 1/4-11	1 7/8-12	60	60	50	33	30	33	627	24-20F642EDMXS	24-20F642EDMXSS	170

Triple-Lok® is delivered with NBR elastomeric seals as standard. For more details on other seal materials see page K93

Order codes shown are part of our current manufacturing programme.

Imperial and metric parts may vary in hexagon dimensions.

$$\frac{\text{PN (bar)}}{10} = \text{PN (MPa)}$$

Pressure ratings – PN shown, apply to Steel and Stainless Steel versions of the product.

F64OMX Swivel male stud

Triple-Lok® 37° Flare female swivel end /
Male BSPP thread – O-ring + retainer ring (ISO 1179)

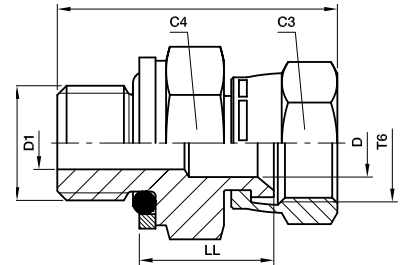

Tube O.D.		Thread BSPP T4	Thread UN/UNF-2B T6	A mm	C3 mm	C4 mm	D mm	D1 mm	LL mm	Weight (steel) g/1 piece	Triple-Lok® Steel	Triple-Lok® Stainless Steel	PN (bar)
mm	in.												
6	1/4	1/8-28	7/16-20	32	16	16	4	4	17	30	4F64OMXS	4F64OMXS	350
6	1/4	1/4-19	7/16-20	35	16	19	4	4	16	30	4-4F64OMXS	4-4F64OMXS	350
8	5/16	1/8-28	1/2-20	32	17	16	6	4	17	28	5F64OMXS	5F64OMXS	350
8	5/16	1/4-19	1/2-20	36	17	19	6	6	18	37	5-4F64OMXS	5-4F64OMXS	350
10	3/8	1/4-19	9/16-18	37	19	19	8	6	18	41	6F64OMXS	6F64OMXS	350
10	3/8	3/8-19	9/16-18	38	19	22	8	8	19	57	6-6F64OMXS	6-6F64OMXS	350
12	1/2	3/8-19	3/4-16	41	22	22	10	10	21	62	8F64OMXS	8F64OMXS	350
12	1/2	1/4-19	3/4-16	39	22	19	10	6	20	57	8-4F64OMXS	8-4F64OMXS	350
12	1/2	1/2-14	3/4-16	42	22	30	10	10	21	75	8-8F64OMXS	8-8F64OMXS	350
14, 15,16	5/8	1/2-14	7/8-14	49	27	30	12	12	24	127	10F64OMXS	10F64OMXS	350
14, 15,16	5/8	3/8-19	7/8-14	43	27	22	12	9	22	84	10-6F64OMXS	10-6F64OMXS	350
18, 20	3/4	3/4-14	1 1/16-12	51	32	36	16	16	26	183	12F64OMXS	12F64OMXS	280
18, 20	3/4	1/2-14	1 1/16-12	50	32	30	16	12	24	169	12-8F64OMXS	12-8F64OMXS	350
25	1	1-11	1 5/16-12	59	38	46	22	22	28	296	16F64OMXS	16F64OMXS	250
25	1	3/4-14	1 5/16-12	54	38	36	22	16	27	253	16-12F64OMXS	16-12F64OMXS	250
28, 30, 32	1 1/4	1 1/4-11	1 5/8-12	64	50	50	28	28	32	500	20F64OMXS	20F64OMXS	250
28, 30, 32	1 1/4	1-11	1 5/8-12	62	50	46	28	22	31	420	20-16F64OMXS	20-16F64OMXS	250
35, 38	1 1/2	1 1/2-11	1 7/8-12	70	60	55	33	33	36	739	24F64OMXS	24F64OMXS	170
35, 38	1 1/2	1 1/4-11	1 7/8-12	70	60	50	33	28	35	627	24-20F64OMXS	24-20F64OMXS	170

Triple-Lok® is delivered with NBR elastomeric seals as standard. For more details on other seal materials see page K93

Order codes shown are part of our current manufacturing programme.

Imperial and metric parts may vary in hexagon dimensions.

$$\frac{\text{PN (bar)}}{10} = \text{PN (MPa)}$$

Pressure ratings – PN shown, apply to Steel and Stainless Steel versions of the product.

F682EDMX Swivel male stud

Triple-Lok® 37° Flare female swivel end / Male metric thread – ED seal (ISO 9974)

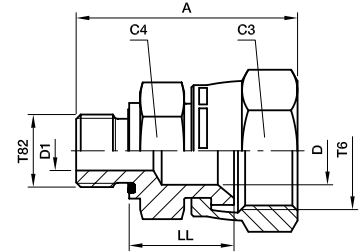

Tube O.D.		Thread Metric T82	Thread UN/UNF-2B T6	A mm	C4 mm	C3 mm	D mm	D1 mm	LL mm	Weight (steel) g/1 piece	Triple-Lok® Steel	Triple-Lok® Stainless Steel	PN (bar)
mm	in.												
6	1/4	M10 x 1.0	7/16-20	24	14	16	4	4	15	28	4M10F682EDMXS	4M10F682EDMXSS	500
8	5/16	M12 x 1.5	1/2-20	29	17	17	6	5	17	32	5M12F682EDMXS	5M12F682EDMXSS	420
10	3/8	M14 x 1.5	9/16-18	30	19	19	8	7	18	42	6M14F682EDMXS	6M14F682EDMXSS	350
12	1/2	M16 x 1.5	3/4-16	34	22	22	10	9	21	62	8M16F682EDMXS	8M16F682EDMXSS	350
12	1/2	M18 x 1.5	3/4-16	34	24	22	10	10	21	70	8M18F682EDMXS	8M18F682EDMXSS	350
14, 15, 16	5/8	M18 x 1.5	7/8-14	36	24	27	12	11	23	125	10M18F682EDMXS	10M18F682EDMXSS	350
14, 15, 16	5/8	M22 x 1.5	7/8-14	38	27	27	12	12	23	155	10M22F682EDMXS	10M22F682EDMXSS	350
18, 20	3/4	M22 x 1.5	1 1/16-12	40	27	32	16	14	25	160	12M22F682EDMXS	12M22F682EDMXSS	350
18, 20	3/4	M27 x 2.0	1 1/16-12	42	32	32	16	16	24	172	12M27F682EDMXS	12M27F682EDMXSS	350
25	1	M33 x 2.0	1 5/16-12	45	41	38	22	22	27	259	16M33F682EDMXS	16M33F682EDMXSS	250
28, 30, 32	1 1/4	M42 x 2.0	1 5/8-12	52	50	50	28	28	32	484	20M42F682EDMXS	20M42F682EDMXSS	250

Triple-Lok® is delivered with NBR elastomeric seals as standard. For more details on other seal materials see page K93
 Order codes shown are part of our current manufacturing programme.
 Imperial and metric parts may vary in hexagon dimensions.

$$\frac{\text{PN (bar)}}{10} = \text{PN (MPa)}$$

Pressure ratings – PN shown, apply to Steel and Stainless Steel versions of the product.

F68OMX Swivel male stud

Triple-Lok® 37° Flare female swivel end / Male metric thread O-ring + retaining ring

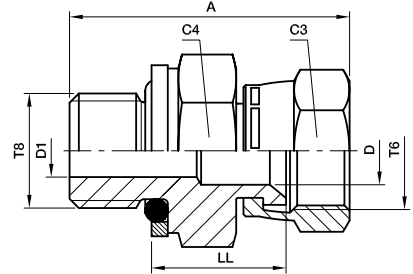

Tube O.D.		Thread Metric T8	Thread UN/UNF-2B T6	A mm	C3 mm	C4 mm	D mm	D1 mm	LL mm	Weight (steel) g/1 piece	Triple-Lok® Steel	PN (bar)
mm	in.											
6	1/4	M10 x 1.0	7/16-20	34	16	14	4	4	16	28	4M10F68OMXS	350
8	5/16	M12 x 1.5	1/2-20	38	17	17	6	6	18	32	5M12F68OMXS	420
10	3/8	M14 x 1.5	9/16-18	39	19	19	8	8	20	42	6M14F68OMXS	350
12	1/2	M16 x 1.5	3/4-16	42	22	22	10	8	22	62	8M16F68OMXS	350
12	1/2	M18 x 1.5	3/4-16	44	22	24	10	10	23	62	8M18F68OMXS	250
14, 15,16	5/8	M18 x 1.5	7/8-14	47	27	24	12	11	25	127	10M18F68OMXS	250
14, 15,16	5/8	M22 x 1.5	7/8-14	48	27	27	12	12	24	155	10M22F68OMXS	250
18, 20	3/4	M27 x 2.0	1 1/16-12	52	32	32	16	16	26	172	12M27F68OMXS	210
25	1	M33 x 2.0	1 5/16-12	57	38	41	22	22	29	259	16M33F68OMXS	210
28, 30, 32	1 1/4	M42 x 2.0	1 5/8-12	62	50	50	28	28	33	484	20M42F68OMXS	210

Triple-Lok® is delivered with NBR elastomeric seals as standard. For more details on other seal materials see page K93
 Order codes shown are part of our current manufacturing programme.
 Imperial and metric parts may vary in hexagon dimensions.

$$\frac{\text{PN (bar)}}{10} = \text{PN (MPa)}$$

K

F6MX Swivel male stud

Triple-Lok® 37° Flare female swivel end / Male NPT* thread (SAE 476)

*Stainless Steel = NPT to prevent galling

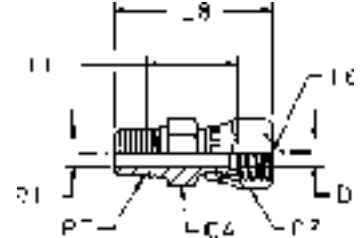

Tube O.D. mm	Tube O.D. in.	Thread NPT/NPTF PT	Thread UN/UNF-2B T6	C3 mm	C4 mm	D mm	D1 mm	L8 mm	LL mm	Weight (steel) g/1 piece	Triple-Lok® Steel	Triple-Lok® Stainless Steel	PN (bar)
6	1/4	1/8-27	7/16-20	14	14	4	4	29	16	18	4 F6X-S	4F6MXSS	420
6	1/4	1/4-18	7/16-20	14	14	4	4	39	22	19	4-4F6MXS	4-4F6MXSS	420
8	5/16	1/8-27	1/2-20	17	14	6	5	35	16	26	5F6MXS	5F6MXSS	420
8	5/16	1/4-18	1/2-20	16	16	6	7	40	22	37	5-4 F6X-S	5-4F6MXSS	420
10	3/8	1/4-16	9/16-18	17	17	8	8	40	24	30	6 F6X-S	6F6MXSS	350
10	3/8	3/8-18	9/16-18	17	19	7	7	40	24	48	6-6 F6X-S	6-6F6MXSS	350
12	1/2	3/8-18	3/4-16	22	22	10	10	43	24	50	8 F6X-S	8F6MXSS	350
12	1/2	1/4-16	3/4-16	22	19	10	7	44	27	46	8-4F6MXS	8-4F6MXSS	350
12	1/2	1/2-14	3/4-16	22	22	10	10	50	28	69	8-8F6MXS	8-8F6MXSS	350
14, 15, 16	5/8	1/2-14	7/8-14	25	25	12	12	52	27	75	10 F6X-S	10F6MXSS	350
14, 15, 16	5/8	3/8-18	7/8-14	27	22	12	10	47	25	67	10-6F6MXS	10-6F6MXSS	350
18, 20	3/4	3/4-14	1 1/16-12	32	27	16	16	55	29	125	12F6MXS	12F6MXSS	350
18, 20	3/4	1/2-14	1 1/16-12	32	27	16	14	55	30	124	12-8F6MXS	12-8F6MXSS	350
25	1	1-11 1/2	1 5/16-12	38	36	22	22	64	48	204	16F6MXS	16F6MXSS	250
25	1	3/4-14	1 5/16-12	38	32	22	18	59	31	169	16-12F6MXS	16-12F6MXSS	250
28, 30, 32	1 1/4	1 1/4-11 1/2	1 5/8-12	50	46	28	28	70	38	496	20F6MXS	20F6MXSS	210
35, 38	1 1/2	1 1/2-11 1/2	1 7/8-12	58	58	34	34	78	43	750	24 F6X-S	24F6MXSS	170

Order codes shown are part of our current manufacturing programme.
Imperial and metric parts may vary in hexagon dimensions.

$$\frac{\text{PN (bar)}}{10} = \text{PN (MPa)}$$

Pressure ratings – PN shown, apply to Steel and Stainless Steel versions of the product.

F63MX Swivel male stud

Triple-Lok® 37° Flare female swivel end / Male BSPT thread (ISO 7)

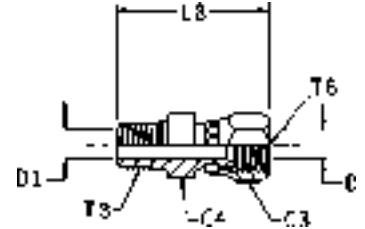

Tube O.D.		Thread BSPT T3	Thread UN/UNF-2B T6	C3 mm	C4 mm	D mm	D1 mm	L8 mm	Weight (steel) g/1 piece	Triple-Lok® Steel	Triple-Lok® Stainless Steel	PN (bar)
mm	in.											
6	1/4	1/8-28	7/16-20	16	13	4	4	34	18	4F63MXS	4F63MXSS	315
6	1/4	1/4-19	7/16-20	16	14	4	4	38	19	4-4F63MXS	4-4F63MXSS	315
8	5/16	1/4-19	1/2-20	17	14	6	6	39	37	5-4F63MXS	5-4F63MXSS	315
10	3/8	1/4-19	9/16-18	19	14	8	8	40	30	6F63MXS	6F63MXSS	315
10	3/8	3/8-19	9/16-18	19	19	8	8	41	48	6-6F63MXS	6-6F63MXSS	315
12	1/2	3/8-19	3/4-16	22	19	10	10	43	50	8F63MXS	8F63MXSS	315
12	1/2	1/4-19	3/4-16	22	19	10	7	41	46	8-4F63MXS	8-4F63MXSS	315
14, 15,16	5/8	1/2-14	7/8-14	27	22	12	12	51	75	10F63MXS	10F63MXSS	315
14, 15,16	5/8	3/8-19	7/8-14	27	22	12	10	46	67	10-6F63MXS	10-6F63MXSS	315
18, 20	3/4	3/4-14	1 1/16-12	32	27	16	16	55	125	12F63MXS	12F63MXSS	160
18, 20	3/4	1/2-14	1 1/16-12	32	27	16	14	55	120	12-8F63MXS	12-8F63MXSS	315
25	1	1-11	1 5/16-12	38	36	22	22	64	204	16F63MXS	16F63MXSS	160
25	1	3/4-14	1 5/16-12	38	32	22	18	59	165	16-12F63MXS	16-12F63MXSS	160
28, 30, 32	1 1/4	1 1/4-11	1 5/8-12	50	46	28	28	69	496	20F63MXS	20F63MXSS	160

Order codes shown are part of our current manufacturing programme.
Imperial and metric parts may vary in hexagon dimensions.

$$\frac{\text{PN (bar)}}{10} = \text{PN (MPa)}$$

Pressure ratings – PN shown, apply to Steel and Stainless Steel versions of the product.

K

C87OMX Male stud elbow

Triple-Lok® 37° Flare end /
Adjustable metric thread – O-ring (ISO 6149)

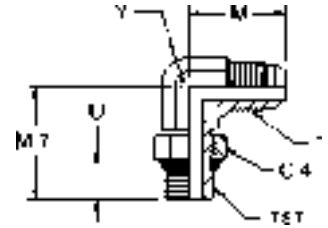

Tube O.D.		Thread Metric T87	Thread UN/UNF-2A T	C4 mm	M mm	M7 mm	U mm	Y mm	Weight (steel) g/1 piece	Triple-Lok® Steel	Triple-Lok® Stainless Steel	PN (bar)
mm	in.											
6	1/4	M10 x 1.0	7/16-20	14	23	27	9	11	17	4M10C87OMXS	4M10C87OMXSS	420
6	1/4	M12 x 1.5	7/16-20	17	24	31	11	13	20	4M12C87OMXS	4M12C87OMXSS	420
8	5/16	M10 x 1.0	1/2-20	14	24	26	9	13	22	5M10C87OMXS	5M10C87OMXSS	420
8	5/16	M12 x 1.5	1/2-20	17	24	31	11	13	25	5M12C87OMXS	5M12C87OMXSS	420
10	3/8	M14 x 1.5	9/16-18	19	27	34	11	14	31	6M14C87OMXS	6M14C87OMXSS	420
10	3/8	M16 x 1.5	9/16-18	22	29	38	12	19	55	6M16C87OMXS	6M16C87OMXSS	350
10	1/2	M16 x 1.5	3/4-16	22	32	38	12	19	65	8M16C87OMXS	8M16C87OMXSS	350
12	1/2	M18 x 1.5	3/4-16	24	32	38	13	19	66	8M18C87OMXS	8M18C87OMXSS	350
14, 15, 16	5/8	M18 x 1.5	7/8-14	24	37	42	13	22	99	10M18C87OMXS	10M18C87OMXSS	350
14, 15, 16	5/8	M22 x 1.5	7/8-14	27	37	43	13	22	99	10M22C87OMXS	10M22C87OMXSS	350
18, 20	3/4	M22 x 1.5	1 1/16-12	27	42	45	13	27	164	12M22C87OMXS	12M22C87OMXSS	350
18, 20	3/4	M27 x 2.0	1 1/16-12	32	42	50	16	27	173	12M27C87OMXS	12M27C87OMXSS	350
25	1	M27 x 2.0	1 5/16-12	32	46	53	16	33	287	16M27C87OMXS	16M27C87OMXSS	280
25	1	M33 x 2.0	1 5/16-12	41	46	53	16	33	287	16M33C87OMXS	16M33C87OMXSS	280
28, 30, 32	1 1/4	M42 x 2.0	1 5/8-12	50	52	58	16	41	575	20M42C87OMXS	20M42C87OMXSS	210
35, 38	1 1/2	M48 x 2.0	1 7/8-12	55	59	64	17	48	874	24M48C87OMXS	24M48C87OMXSS	140

Triple-Lok® is delivered with NBR elastomeric seals as standard. For more details on other seal materials see page K93
Order codes shown are part of our current manufacturing programme.
Imperial and metric parts may vary in hexagon dimensions.

$$\frac{\text{PN (bar)}}{10} = \text{PN (MPa)}$$

Pressure ratings – PN shown, apply to Steel and Stainless Steel versions of the product.

C50MX Male stud elbow

Triple-Lok® 37° Flare end /
Adjustable UN/UNF thread – O-ring (ISO 11926)
SAE 070220 MS51527

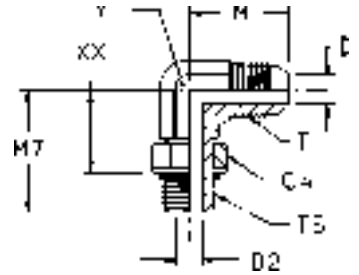

Tube O.D.		Thread UN/UNF-2A T5	Thread UN/UNF-2A T	C4 mm	D mm	D2 mm	M mm	M7 mm	XX mm	Y mm	Weight (steel) g/1 piece	Triple-Lok® Steel	Triple-Lok® Stainless Steel	PN (bar)
6	1/8	5/16-24	5/16-24	11	2	2	20	24	15	11	25	2 C50X-S		350
	3/16	3/8-24	3/8-24	13	3	3	21	24	16	11	30	3 C50X-S		350
	1/4	7/16-20	7/16-20	14	4	4	23	26	16	11	37	4C50MXS	4C50MXSS	420
	6	1/4	9/16-18	7/16-20	17	4	8	27	32	21	43	4-6 C50X-S	4-6C50MXSS	420
8	5/16	1/2-20	1/2-20	16	6	6	24	29	18	13	47	5C50MXS	5C50MXSS	420
8	5/16	7/16-18	1/2-20	14	6	5	24	29	19	14	55	5-4 C50X-S	5-4C50MXSS	420
8	5/16	9/16-18	1/2-20	17	6	8	24	32	20	14	62	5-6 C50X-S	5-6C50MXSS	420
10	3/8	9/16-18	9/16-18	17	8	8	27	32	21	14	63	6C50MXS	6C50MXSS	420
10	3/8	7/16-20	9/16-18	14	8	4	27	30	20	14	99	6-4 C50X-S	6-4C50MXSS	420
10	3/8	1/2-20	9/16-18	16	8	6	27	30	18	14	99	6-5 C50X-S	6-5C50MXSS	420
10	3/8	3/4-16	9/16-18	22	8	10	29	37	24	19	125	6-8C50MXS	6-8C50MXSS	420
10	3/8	7/8-14	9/16-18	25	8	12	31	43	32	22	145	6-10 C50X-S	6-10C50MXSS	350
12	1/2	3/4-16	3/4-16	22	10	10	32	37	24	19	160	8C50MXS	8C50MXSS	420
12	1/2	7/16-18	3/4-16	14	10	5	32	32	22	19	150	8-4 C50X-S	8-4C50MXSS	420
12	1/2	9/16-18	3/4-16	17	10	8	32	34	23	19	130	8-6C50MXS	8-6C50MXSS	420
12	1/2	7/8-14	3/4-16	27	10	13	34	43	29	22	180	8-10C50MXS	8-10C50MXSS	350
12	1/2	1 1/16-12	3/4-16	32	10	16	36	49	33	27	210	8-12C50MXS	8-12C50MXSS	350
12	1/2	1 5/16-12	3/4-16	41	10	22	39	52	36	33	380	8-16 C50X-S	8-16C50MXSS	280
14, 15, 16	5/8	7/8-14	7/8-14	27	12	13	37	43	29	22	186	10C50MXS	10C50MXSS	350
14, 15, 16	5/8	9/16-18	7/8-14	18	13	8	37	36	25	22	130	10-6 C50X-S	10-6C50MXSS	350
14, 15, 16	5/8	3/4-16	7/8-14	22	12	10	37	39	27	22	157	10-8C50MXS	10-8C50MXSS	350
14, 15, 16	5/8	1 1/16-12	7/8-14	32	12	16	39	49	33	27	331	10-12C50MXS	10-12C50MXSS	350
14, 15, 16	5/8	1 5/16-12	7/8-14	41	13	22	42	52	36	33	400	10-16 C50X-S	10-16C50MXSS	280
18, 20	3/4	1 1/16-12	1 1/16-12	32	16	16	42	49	33	27	301	12C50MXS	12C50MXSS	350
18, 20	3/4	3/4-16	1 1/16-12	22	16	10	42	41	30	27	297	12-8 C50X-S	12-8C50MXSS	350
18, 20	3/4	7/8-14	1 1/16-12	27	16	13	42	45	31	27	297	12-10C50MXS	12-10C50MXSS	350
18, 20	3/4	1 3/16-12	1 1/16-12	35	16	18	45	51	34	33	350	12-14 C50X-S		280
18, 20	3/4	1 5/16-12	1 1/16-12	38	16	22	46	52	36	33	421	12-16 C50X-S	12-16C50MXSS	280
22	7/8	1 3/16-12	1 3/16-12	35	18	18	44	51	34	33	417	14 C50X-S		280
25	1	1 5/16-12	1 5/16-12	38	22	22	46	52	36	33	426	16C50MXS	16C50MXSS	280
25	1	1 1/16-12	1 5/16-12	32	22	16	46	52	36	33	418	16-12C50MXS	16-12C50MXSS	280
25	1	1 3/16-12	1 5/16-12	35	22	18	46	53	36	33	450	16-14 C50X-S		280
25	1	1 5/8-12	1 5/16-12	48	22	28	51	57	41	41	546	16-20 C50X-S	16-20C50MXSS	280
25	1	1 7/8-12	1 5/16-12	55	22	34	55	61	44	48	600	16-24 C50X-S	16-24C50MXSS	210
28, 30, 32	1 1/4	1 5/8-12	1 5/8-12	50	28	28	52	57	41	41	674	20C50MXS	20C50MXSS	280
28, 30, 32	1 1/4	1 5/16-12	1 5/8-12	41	28	22	52	57	41	41	650	20-16 C50X-S	20-16C50MXSS	280
28, 30, 32	1 1/4	1 7/8-12	1 5/8-12	55	28	34	56	61	44	48	920	20-24 C50X-S	20-24C50MXSS	210
35, 38	1 1/2	1 7/8-12	1 7/8-12	55	33	33	59	61	44	48	917	24 C50X-S	24C50MXSS	210
35, 38	1 1/2	1 5/8-12	1 7/8-12	48	34	28	59	61	44	48	920	24-20 C50X-S	24-20C50MXSS	210

Triple-Lok® is delivered with NBR elastomeric seals as standard. For more details on other seal materials see page K93
Order codes shown are part of our current manufacturing programme.
Imperial and metric parts may vary in hexagon dimensions.

$$\frac{\text{PN (bar)}}{10} = \text{PN (MPa)}$$

Pressure ratings – PN shown, apply to Steel and Stainless Steel versions of the product.

CC50X Extended male stud elbow

Triple-Lok® 37° Flare end / Male UNF thread – O-ring (ISO 11926)

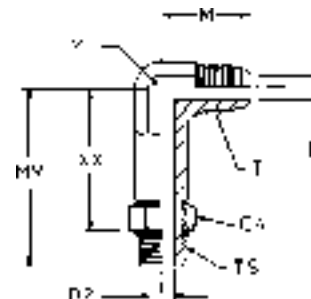

Tube O.D.		Thread UN/UNF-2A T5	Thread UN/UNF-2A T	C4 mm	D mm	D2 mm	M mm	M9 mm	XX mm	Y mm	Weight (steel) g/1 piece	Triple-Lok® Steel	PN (bar)
mm	in.												
6	1/4	7/16-20	7/16-20	14	4	4	25	44	34	14	44	4 CC50X-S	420
10	3/8	9/16-18	9/16-18	18	8	8	27	53	42	14	51	6 CC50X-S	420
12	1/2	3/4-16	3/4-16	22	10	10	32	64	51	22	146	8 CC50X-S	420
14, 15, 16	5/8	7/8-14	7/8-14	25	12	12	37	73	59	22	169	10 CC50X-S	350
18, 20	3/4	1 1/16-12	1 1/16-12	32	16	16	42	85	68	27	291	12 CC50X-S	350
25	1	1 5/16-12	1 5/16-12	38	21	21	46	95	78	33	481	16 CC50X-S	280

Triple-Lok® is delivered with NBR elastomeric seals as standard. For more details on other seal materials see page K93
 Order codes shown are part of our current manufacturing programme.
 Imperial and metric parts may vary in hexagon dimensions.

$$\frac{\text{PN (bar)}}{10} = \text{PN (MPa)}$$

C4OMX Male stud elbow

Triple-Lok® 37° Flare end / Adjustable BSPP thread O-ring + retaining ring (ISO 1179)

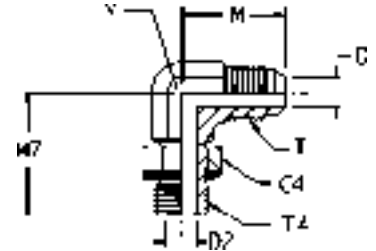

Tube O.D.		Thread BSPP T4	Thread UN/UNF-2A T	C4 mm	D mm	D2 mm	M mm	M7 mm	Y mm	Weight (steel) g/1 piece	Triple-Lok® Steel	Triple-Lok® Stainless Steel	PN (bar)
mm	in.												
6	1/4	1/8-28	7/16-20	14	4	4	23	27	11	37	4C4OMXS	4C4OMXS	250
6	1/4	1/4-19	7/16-20	19	4	8	27	32	14	43	4-4C4OMXS	4-4C4OMXS	250
6	1/4	3/8-19	7/16-20	22	4	10	29	37	19	50	4-6C4OMXS	4-6C4OMXS	250
8	5/16	1/8-28	1/2-20	14	6	4	24	27	13	47	5C4OMXS	5C4OMXS	250
8	5/16	1/4-19	1/2-20	19	6	8	27	32	14	55	5-4C4OMXS	5-4C4OMXS	250
8	5/16	3/8-19	1/2-20	22	6	10	29	37	19	57	5-6C4OMXS	5-6C4OMXS	250
10	3/8	1/4-19	9/16-18	19	8	8	27	32	14	61	6C4OMXS	6C4OMXS	250
10	3/8	1/8-28	9/16-18	14	8	4	27	28	14	52	6-2C4OMXS	6-2C4OMXS	250
10	3/8	3/8-19	9/16-18	22	8	10	29	37	19	95	6-6C4OMXS	6-6C4OMXS	250
10	3/8	1/2-14	9/16-18	27	8	12	31	43	22	80	6-8C4OMXS	6-8C4OMXS	250
12	1/2	3/8-19	3/4-16	22	10	10	32	37	19	102	8C4OMXS	8C4OMXS	250
12	1/2	1/4-19	3/4-16	19	10	8	32	37	19	91	8-4C4OMXS	8-4C4OMXS	250
12	1/2	1/2-14	3/4-16	27	10	12	34	43	22	155	8-8C4OMXS	8-8C4OMXS	250
12	1/2	3/4-14	3/4-16	36	10	16	36	50	27	205	8-12C4OMXS	8-12C4OMXS	250
14, 15, 16	5/8	1/2-14	7/8-14	27	12	12	37	43	22	164	10C4OMXS	10C4OMXS	250
14, 15, 16	5/8	3/8-19	7/8-14	22	12	10	37	36	22	190	10-6C4OMXS	10-6C4OMXS	250
14, 15, 16	5/8	3/4-14	7/8-14	36	12	16	39	50	27	217	10-12C4OMXS	10-12C4OMXS	250
18, 20	3/4	3/4-14	1 1/16-12	36	16	16	42	50	27	295	12C4OMXS	12C4OMXS	250
18, 20	3/4	1/2-14	1 1/16-12	27	16	12	42	50	27	245	12-8C4OMXS	12-8C4OMXS	250
18, 20	3/4	1-11	1 1/16-12	41	16	22	45	52	33	317	12-16C4OMXS	12-16C4OMXS	250
25	1	1-11	1 5/16-12	41	22	22	46	52	33	425	16C4OMXS	16C4OMXS	250
25	1	3/4-14	1 5/16-12	36	22	16	46	47	33	405	16-12C4OMXS	16-12C4OMXS	250
28, 30, 32	1 1/4	1 1/4-11	1 5/8-12	50	28	28	52	57	41	697	20C4OMXS	20C4OMXS	210
28, 30, 32	1 1/4	1-11	1 5/8-12	41	28	22	52	57	41	650	20-16C4OMXS	20-16C4OMXS	250
35, 38	1 1/2	1 1/2-11	1 7/8-12	55	33	33	59	61	48	953	24C4OMXS	24C4OMXS	140
35, 38	1 1/2	1 1/4-11	1 7/8-12	50	33	28	59	61	48	964	24-20C4OMXS	24-20C4OMXS	210

Triple-Lok® is delivered with NBR elastomeric seals as standard. For more details on other seal materials see page K93

Order codes shown are part of our current manufacturing programme.

Imperial and metric parts may vary in hexagon dimensions.

$$\frac{\text{PN (bar)}}{10} = \text{PN (MPa)}$$

Pressure ratings – PN shown, apply to Steel and Stainless Steel versions of the product.

C8OMX Male stud elbow

Triple-Lok® 37° Flare end / Male metric thread – O-ring + retainer ring

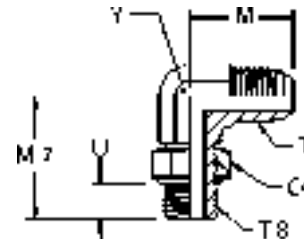

Tube O.D.		Thread Metric T8	Thread UN/UNF-2A T	M mm	Y mm	U mm	C4 mm	M7 mm	Weight (steel) g/1 piece	Triple-Lok® Steel	PN (bar)
mm	in.										
6	1/4	M10 x 1.0	7/16-20	23	11	8	13	27	23	4M10C8OMXS	250
6	1/4	M12 x 1.5	7/16-20	24	13	10	17	31	28	4M12C8OMXS	250
8	5/16	M10 x 1.0	1/2-20	24	13	8	13	26	29	5M10C8OMXS	250
8	5/16	M12 x 1.5	1/2-20	24	13	10	17	31	29	5M12C8OMXS	250
10	3/8	M14 x 1.5	9/16-18	27	14	10	17	34	36	6M14C8OMXS	250
10	3/8	M16 x 1.5	9/16-18	29	19	10	19	38	74	6M16C8OMXS	250
12	1/2	M16 x 1.5	3/4-16	32	19	10	19	38	77	8M16C8OMXS	250
12	1/2	M18 x 1.5	3/4-16	32	19	11	22	38	78	8M18C8OMXS	250
14, 15, 16	5/8	M18 x 1.5	7/8-14	37	22	11	22	42	104	10M18C8OMXS	250
14, 15, 16	5/8	M20 x 1.5	7/8-14	37	22	11	24	41	110	10M20C8OMXS	250
14, 15, 16	5/8	M22 x 1.5	7/8-14	37	22	12	27	43	119	10M22C8OMXS	250
18, 20	3/4	M22 x 1.5	1 1/16-12	42	27	12	27	45	198	12M22C8OMXS	250
18, 20	3/4	M27 x 2.0	1 1/16-12	42	27	14	32	50	208	12M27C8OMXS	175
25	1	M27 x 2.0	1 5/16-12	46	33	14	32	53	333	16M27C8OMXS	175
25	1	M33 x 2.0	1 5/16-12	46	33	14	38	53	333	16M33C8OMXS	140
28, 30, 32	1 1/4	M42 x 2.0	1 5/8-12	52	41	14	50	58	575	20M42C8OMXS	140
35, 38	1 1/2	M48 x 2.0	1 7/8-12	59	48	15	55	64	872	24M48C8OMXS	140

Triple-Lok® is delivered with NBR elastomeric seals as standard. For more details on other seal materials see page K93
 Order codes shown are part of our current manufacturing programme.
 Imperial and metric parts may vary in hexagon dimensions.

$$\frac{\text{PN (bar)}}{10} = \text{PN (MPa)}$$

CMTX Male stud elbow

Triple-Lok® 37° Flare end / Male NPTF* thread (SAE 476)
SAE 070202 MS51504

*Stainless Steel = NPT to prevent galling

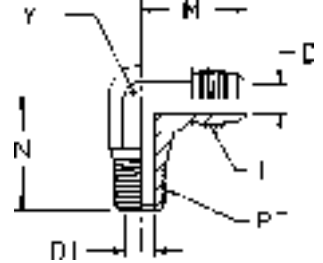

Tube O.D. mm	in.	Thread NPT/NPTF PT	Thread UN/UNF-2A T	D mm	D1 mm	M mm	N mm	Y mm	Weight (steel) g/1 piece	Triple-Lok® Steel	Triple-Lok® Stainless Steel	PN (bar)
6	1/8	1/8-27	5/16-24	2	5	20	18	8	12	2 CTX-S		420
	3/16	1/8-27	3/8-24	3	5	21	18	10	15	3 CTX-S		420
	1/4	1/8-27	7/16-20	4	5	23	20	11	23	4CMTXS	4CMTXSS	420
	1/4	1/4-18	7/16-20	4	7	27	28	14	42	4-4CMTXS	4-4CMTXSS	420
	1/4	3/8-18	7/16-20	4	10	29	31	19	26	4-6 CTX-S	4-6CMTXSS	420
6	1/4	1/2-14	7/16-20	4	14	31	37	22	30	4-8 CTX-S	4-8CMTXSS	420
8	5/16	1/8-27	1/2-20	6	5	24	20	13	29	5CMTXS	5CMTXSS	420
8	5/16	1/4-18	1/2-20	6	7	27	28	14	42	5-4CMTXS	5-4CMTXSS	420
8	5/16	3/8-18	1/2-20	6	10	29	31	19	45	5-6 CTX-S	5-6CMTXSS	420
10	3/8	1/4-16	9/16-18	8	7	27	28	14	45	6CMTXS	6CMTXSS	420
10	3/8	1/8-27	9/16-18	8	5	27	23	14	55	6-2CMTXS	6-2CMTXSS	420
10	3/8	3/8-18	9/16-18	8	10	29	31	19	76	6-6CMTXS	6-6CMTXSS	420
10	3/8	1/2-14	9/16-18	8	14	31	37	22	117	6-8CMTXS	6-8CMTXSS	420
12	1/2	3/8-18	3/4-16	10	10	32	31	19	86	8CMTXS	8CMTXSS	420
12	1/2	1/4-16	3/4-16	10	7	32	31	19	82	8-4CMTXS	8-4CMTXSS	420
12	1/2	1/2-14	3/4-16	10	14	34	37	22	125	8-8CMTXS	8-8CMTXSS	420
12	1/2	3/4-14	3/4-16	10	18	36	40	27	190	8-12 CTX-S	8-12CMTXSS	280
14, 15,16	5/8	1/2-14	7/8-14	12	14	37	37	22	129	10CMTXS	10CMTXSS	350
14, 15,16	5/8	3/8-18	7/8-14	12	10	37	33	22	127	10-6 CTX-S	10-6CMTXSS	350
14, 15,16	5/8	3/4-14	7/8-14	12	18	39	40	27	192	10-12CMTXS	10-12CMTXSS	280
18, 20	3/4	3/4-14	1 1/16-12	16	18	42	40	27	198	12CMTXS	12CMTXSS	280
18, 20	3/4	1/2-14	1 1/16-12	16	14	42	40	27	204	12-8 CTX-S	12-8CMTXSS	350
18, 20	3/4	1-11 1/2	1 1/16-12	16	24	45	50	33	318	12-16CMTXS	12-16CMTXSS	210
22	7/8	3/4-14	1 3/16-12	18	18	46	43	31	260	14 CTX-S	14CMTXSS	280
25	1	1-11 1/2	1 5/16-12	22	24	46	50	33	328	16CMTXS	16CMTXSS	210
25	1	3/4-14	1 5/16-12	22	18	46	45	33	318	16-12 CTX-S	16-12CMTXSS	280
25	1	1 1/4-11 1/2	1 5/16-12	22	32	54	61	45	477	16-20 CTX-S	16-20CMTXSS	170
28, 30, 32	1 1/4	1 1/4-11 1/2	1 5/8-12	28	32	52	61	45	549	20 CTX-S	20CMTXSS	170
28, 30, 32	1 1/4	1-11 1/2	1 5/8-12	28	24	52	60	41	536	20-16CMTXS	20-16CMTXSS	210
28, 30, 32	1 1/4	1 1/2-11 1/2	1 7/8-12	28	38	56	67	48	630	20-24 CTX-S	20-24CMTXSS	170
35, 38	1 1/2	1 1/2-11 1/2	1 7/8-12	33	38	59	67	48	747	24 CTX-S	24CMTXSS	170
35, 38	1 1/2	1 1/4-11 1/2	1 7/8-12	33	32	59	57	48	715	24-20 CTX-S	24-20CMTXSS	170
	2	2-11/12	2 1/2-12	45	49	78	76	64	1644	32 CTX-S		140
	2	1 1/2-11 1/2	2 1/2-12	45	38	78	75	66	1450	32-24 CTX-S		140

Order codes shown are part of our current manufacturing programme.
Imperial and metric parts may vary in hexagon dimensions.

$$\frac{\text{PN (bar)}}{10} = \text{PN (MPa)}$$

Pressure ratings – PN shown, apply to Steel and Stainless Steel versions of the product.

CCTX Extended male stud elbow

Triple-Lok® 37° Flare end / Male NPTF* thread (SAE 476)
SAE 070202 MS51504

*Stainless Steel = NPT to prevent galling

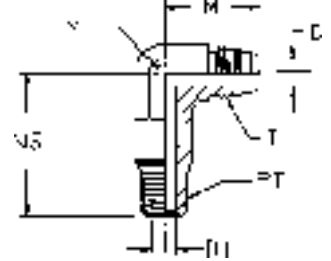

Tube O.D.		Thread NPT/NPTF PT	Thread UN/UNF-2A T	D mm	D1 mm	M mm	N3 mm	Y mm	Weight (steel) g/1 piece	Triple-Lok® Steel	Triple-Lok® Stainless Steel	PN (bar)
mm	in.											
6	1/4	1/8-27	7/16-20	5	5	23	30	11	28	4 CCTX-S	4 CCTX-SS	420
6	1/4	1/4-18	7/16-20	5	7	27	37	14	28	4-4 CCTX-S	4-4 CCTX-SS	420
8	5/16	1/8-27	1/2-20	6	5	24	30	14	35	5 CCTX-S	5 CCTX-SS	420
10	3/8	1/4-16	9/16-18	8	7	27	40	14	58	6 CCTX-S	6 CCTX-SS	420
10	3/8	3/8-18	9/16-18	8	11	29	46	19	58	6-6 CCTX-S	6-6 CCTX-SS	420
12	1/2	3/8-18	3/4-16	10	10	32	45	19	111	8 CCTX-S	8 CCTX-SS	420
12	1/2	1/2-14	3/4-16	10	14	34	55	22	136	8-8 CCTX-S	8-8 CCTX-SS	420
14, 15, 16	5/8	1/2-14	7/8-14	13	14	37	55	22	183	10 CCTX-S	10 CCTX-SS	350
18, 20	3/4	3/4-14	1 1/16-12	16	18	42	61	27	253	12 CCTX-S	12 CCTX-SS	280
25	1	1-11 1/2	1 5/16-12	21	24	46	76	33	435	16 CCTX-S	16 CCTX-SS	210
28, 30, 32	1 1/4	1 1/4-11 1/2	1 5/8-12	28	32	52	93	41	1021	20 CCTX-S	20 CCTX-SS	170

Order codes shown are part of our current manufacturing programme.
Imperial and metric parts may vary in hexagon dimensions.

$$\frac{\text{PN (bar)}}{10} = \text{PN (MPa)}$$

Pressure ratings – PN shown, apply to Steel and Stainless Steel versions of the product.

CCCTX Extended male stud elbow

Triple-Lok® 37° Flare end / Male NPTF* thread (SAE 476)
SAE 071602

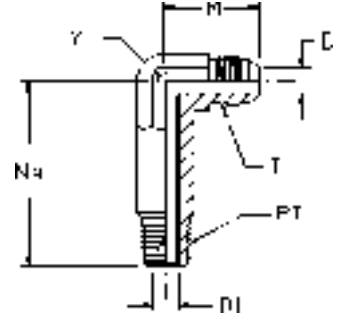

Tube O.D.		Thread NPT/NPTF PT	Thread UN/UNF-2A T	D mm	D1 mm	M mm	N4 mm	Y mm	Weight (steel) g/1 piece	Triple-Lok® Steel	PN (bar)
mm	in.										
6	1/4	1/8-27	7/16-20	5	5	23	40	11	32	4 CCCTX-S	420
6	1/4	1/4-18	7/16-20	5	7	27	52	14	32	4-4 CCCTX-S	420
8	5/16	1/8-27	1/2-20	6	5	25	41	14	39	5 CCCTX-S	420
10	3/8	1/4-16	9/16-18	8	7	27	53	14	72	6 CCCTX-S	420
10	3/8	3/8-18	9/16-18	8	11	29	59	19	72	6-6 CCCTX-S	420
12	1/2	3/8-18	3/4-16	10	10	32	59	19	130	8 CCCTX-S	420
12	1/2	1/2-14	3/4-16	10	14	34	72	22	163	8-8 CCCTX-S	420
14, 15, 16	5/8	1/2-14	7/8-14	13	14	37	72	22	212	10 CCCTX-S	350
18, 20	3/4	3/4-14	1 1/16-12	16	18	42	82	27	356	12 CCCTX-S	280
25	1	1-11 1/2	1 5/16-12	21	24	46	101	33	520	16 CCCTX-S	210
28, 30, 32	1 1/4	1 1/4-11 1/2	1 5/8-12	28	32	52	126	41	1196	20 CCCTX-S	170

Order codes shown are part of our current manufacturing programme.
Imperial and metric parts may vary in hexagon dimensions.

$$\frac{\text{PN (bar)}}{10} = \text{PN (MPa)}$$

C3MX Male stud elbow

Triple-Lok® 37° Flare end / Male BSPT thread (ISO 7)

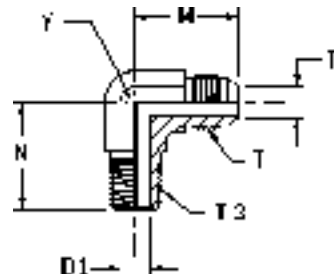

Tube O.D.		Thread BSPT T3	Thread UN/UNF-2A T	D mm	D1 mm	M mm	N mm	Y mm	Weight (steel) g/1 piece	Triple-Lok® Steel	Triple-Lok® Stainless Steel	PN (bar)
mm	in.											
6	1/4	1/8-28	7/16-20	4	5	23	20	11	23	4C3MXS	4C3MXSS	315
6	1/4	1/4-19	7/16-20	4	7	27	28	14	42	4-4C3MXS	4-4C3MXSS	315
8	5/16	1/8-28	1/2-20	6	5	24	20	13	29	5C3MXS	5C3MXSS	315
8	5/16	1/4-19	1/2-20	6	7	27	28	14	42	5-4C3MXS	5-4C3MXSS	315
10	3/8	1/4-19	9/16-18	8	7	27	28	14	45	6C3MXS	6C3MXSS	315
10	3/8	3/8-19	9/16-18	8	10	29	31	19	76	6-6C3MXS	6-6C3MXSS	315
10	3/8	1/2-14	9/16-18	8	14	31	37	22	117	6-8C3MXS	6-8C3MXSS	315
12	1/2	3/8-19	3/4-16	10	10	32	31	19	86	8C3MXS	8C3MXSS	315
12	1/2	1/4-19	3/4-16	10	7	32	31	19	82	8-4C3MXS	8-4C3MXSS	315
12	1/2	1/2-14	3/4-16	10	14	34	37	22	125	8-8C3MXS	8-8C3MXSS	315
14, 15, 16	5/8	1/2-14	7/8-14	12	14	37	37	22	129	10C3MXS	10C3MXSS	315
14, 15, 16	5/8	3/8-19	7/8-14	12	10	37	33	22	127	10-6C3MXS	10-6C3MXSS	315
14, 15, 16	5/8	3/4-14	7/8-14	12	18	39	40	27	192	10-12C3MXS	10-12C3MXSS	160
18, 20	3/4	3/4-14	1 1/16-12	16	18	42	40	27	198	12C3MXS	12C3MXSS	160
18, 20	3/4	1/2-14	1 1/16-12	16	14	42	40	27	204	12-8C3MXS	12-8C3MXSS	315
18, 20	3/4	1-11	1 1/16-12	16	24	45	50	33	251	12-16C3MXS	12-16C3MXSS	160
25	1	1-11	1 5/16-12	22	24	46	50	33	328	16C3MXS	16C3MXSS	160
25	1	3/4-14	1 5/16-12	22	18	46	45	33	318	16-12C3MXS	16-12C3MXSS	160
28, 30, 32	1 1/4	1 1/4-11	1 5/8-12	28	32	52	61	41	549	20C3MXS	20C3MXSS	160
28, 30, 32	1 1/4	1-11	1 5/8-12	28	24	52	60	41	536	20-16C3MXS	20-16C3MXSS	160
35, 38	1 1/2	1 1/2-11	1 7/8-12	33	38	59	67	48	747	24C3MXS	24C3MXSS	160

Order codes shown are part of our current manufacturing programme.
Imperial and metric parts may vary in hexagon dimensions.

$$\frac{\text{PN (bar)}}{10} = \text{PN (MPa)}$$

Pressure ratings – PN shown, apply to Steel and Stainless Steel versions of the product.

V87OMX 45° Male stud elbow

Triple-Lok® 37° Flare end / Male metric thread O-ring (ISO 6149)

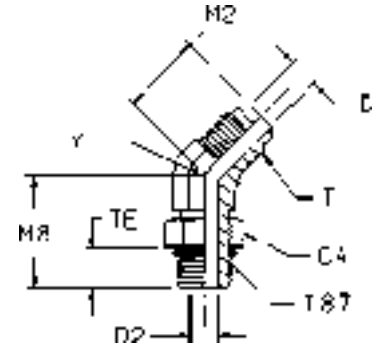

Tube O.D.		Thread Metric T87	Thread UN/UNF-2A T	C4 mm	D mm	D2 mm	M2 mm	M8 mm	TE mm	Y mm	Weight (steel) g/1 piece	Triple-Lok® Steel	PN (bar)
mm	in.												
6	1/4	M10 x 1.0	7/16-20	14	4	5	18	27	9	11	17	4M10V87OMXS	420
4	1/4	M12 x 1.0	7/16-20	17	4	6	20	28	11	13	25	4M12V87OMXS	420
8	5/16	M10 x 1.0	1/2-20	14	6	5	18	27	9	13	31	5M10V87OMXS	420
8	5/16	M12 x 1.5	1/2-20	17	6	6	20	28	11	13	25	5M12V87OMXS	420
10	3/8	M14 x 1.5	9/16-18	19	8	8	21	28	11	14	31	6M14V87OMXS	420
10	3/8	M16 x 1.5	9/16-18	22	8	9	22	32	12	19	58	6M16V87OMXS	350
10	3/8	M18 x 1.5	9/16-18	24	8	11	22	33	13	19	66	6M18V87OMXS	350
12	1/2	M16 x 1.5	3/4-16	22	10	9	25	33	12	19	65	8M16V87OMXS	350
12	1/2	M18 x 1.5	3/4-16	24	10	11	25	33	13	19	66	8M18V87OMXS	350
14, 15, 16	5/8	M18 x 1.5	7/8-14	24	12	11	28	37	13	22	99	10M18V87OMXS	350
14, 15, 16	5/8	M22 x 1.5	7/8-14	27	12	14	28	38	13	22	99	10M22V87OMXS	350
18, 20	3/4	M22 x 1.5	1 1/16-12	27	16	14	33	40	13	27	164	12M22V87OMXS	350
18, 20	3/4	M27 x 2.0	1 1/16-12	32	16	18	33	46	16	27	173	12M27V87OMXS	350
25	1	M33 x 2.0	1 5/16-12	41	22	23	37	46	16	33	287	16M33V87OMXS	280

Triple-Lok® is delivered with NBR elastomeric seals as standard. For more details on other seal materials see page K93
Order codes shown are part of our current manufacturing programme.
Imperial and metric parts may vary in hexagon dimensions.

$$\frac{\text{PN (bar)}}{10} = \text{PN (MPa)}$$

K

V5OMX 45° Male stud elbow

Triple-Lok® 37° Flare end / Male UNF thread O-ring (ISO 11926)
SAE 070320 MS51528

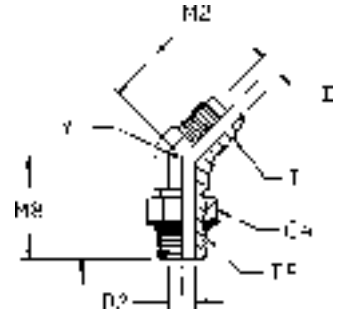

Tube O.D.		Thread UN/UNF-2A T5	Thread UN/UNF-2A T	C4 mm	D mm	D2 mm	M2 mm	M8 mm	Y mm	Weight (steel) g/1 piece	Triple-Lok® Steel	Triple-Lok® Stainless Steel	PN (bar)
mm	in.												
6	1/4	7/16-20	7/16-20	14	4	5	18	27	11	34	4V50MXS	4 V50X-SS	420
8	5/16	1/2-20	1/2-20	16	6	6	20	27	13	42	5V50MXS	5 V50X-SS	420
10	3/8	9/16-18	9/16-18	17	8	8	21	29	14	52	6V50MXS	6 V50X-SS	420
10	3/8	3/4-16	9/16-19	22	8	10	22	33	19	104	6-8 V50X-S	6-8 V50X-SS	420
12	1/2	3/4-16	3/4-16	22	10	10	25	33	19	104	8V50MXS	8 V50X-SS	420
12	1/2	9/16-18	3/4-16	17	10	8	25	30	19	98	8-6V50MXS	8-6 V50X-SS	420
12	1/2	7/8-14	3/4-16	25	10	12	25	39	22	148	8-10 V50X-S	8-10 V50X-SS	350
14, 15, 16	5/8	7/8-14	7/8-14	27	12	13	28	39	22	157	10V50MXS	10 V50X-SS	350
14, 15, 16	5/8	3/4-16	7/8-14	22	12	10	28	35	22	157	10-8V50MXS	10-8 V50X-SS	350
18, 20	3/4	1 1/16-12	1 1/16-12	32	16	16	33	44	27	258	12V50MXS	12 V50X-SS	350
18, 20	3/4	7/8-14	1 1/16-12	25	16	12	33	40	27	227	12-10 V50X-S	12-10 V50X-SS	350
22	7/8	1 3/16-12	1 3/16-12	35	18	18	37	47	33	275	14 V50X-S		280
25	1	1 5/16-12	1 5/16-12	38	22	22	37	47	33	375	16V50MXS	16 V50X-SS	280
28, 30, 32	1 1/4	1 5/8-12	1 5/8-12	48	28	28	40	49	41	570	20 V50X-S	20 V50X-SS	280
35, 38	1 1/2	1 7/8-12	1 7/8-12	54	33	33	45	49	48	706	24 V50X-S	24 V50X-SS	210

Triple-Lok® is delivered with NBR elastomeric seals as standard. For more details on other seal materials see page K93
Order codes shown are part of our current manufacturing programme.
Imperial and metric parts may vary in hexagon dimensions.

$$\frac{\text{PN (bar)}}{10} = \text{PN (MPa)}$$

Pressure ratings – PN shown, apply to Steel and Stainless Steel versions of the product.

V4OMX 45° Male stud elbow

Triple-Lok® 37° Flare end / Male BSPP thread O-ring + retaining ring (ISO 1179)

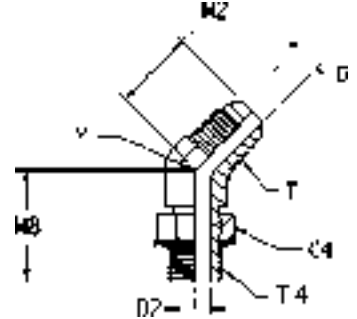

Tube O.D.		Thread BSPP T4	Thread UN/UNF-2A T	C4 mm	D mm	D2 mm	M2 mm	M8 mm	Y mm	Weight (steel) g/1 piece	Triple-Lok® Steel	PN (bar)
mm	in.											
6	1/4	1/8-28	7/16-20	14	4	4	18	27	11	35	4V4OMXS	250
6	1/4	1/4-19	7/16-20	19	4	8	21	29	14	48	4-4V4OMXS	250
8	5/16	1/8-28	1/2-20	14	6	4	20	27	13	44	5V4OMXS	250
8	5/16	1/4-19	1/2-20	19	6	8	21	27	14	51	5-4V4OMXS	250
10	3/8	1/4-19	9/16-18	19	8	8	21	29	14	55	6V4OMXS	250
10	3/8	3/8-19	9/16-18	22	8	10	22	33	19	70	6-6V4OMXS	250
10	3/8	1/2-14	9/16-18	27	8	12	22	39	22	92	6-8V4OMXS	250
12	1/2	3/8-19	3/4-16	22	10	10	25	33	19	104	8V4OMXS	250
12	1/2	1/2-14	3/4-16	27	10	12	25	39	22	148	8-8V4OMXS	250
14, 15, 16	5/8	1/2-14	7/8-14	27	10	12	28	39	22	165	10V4OMXS	250
14, 15, 16	5/8	3/4-14	7/8-14	36	12	16	30	44	27	235	10-12V4OMXS	250
18, 20	3/4	3/4-14	1 1/16-12	36	16	16	33	44	27	270	12V4OMXS	250
25	1	1-11	1 5/16-12	41	22	22	37	47	33	394	16V4OMXS	250
28, 30, 32	1 1/4	1 1/4-11	1 5/8-12	50	28	28	40	48	41	599	20V4OMXS	210
35, 38	1 1/2	1 1/2-11	1 7/8-12	55	33	33	45	48	48	750	24V4OMXS	140

Triple-Lok® is delivered with NBR elastomeric seals as standard. For more details on other seal materials see page K93
Order codes shown are part of our current manufacturing programme.
Imperial and metric parts may vary in hexagon dimensions.

$$\frac{\text{PN (bar)}}{10} = \text{PN (MPa)}$$

V8OMX 45° Male stud elbow

Triple-Lok® 37° Flare end / Male metric thread – O-ring + retaining ring

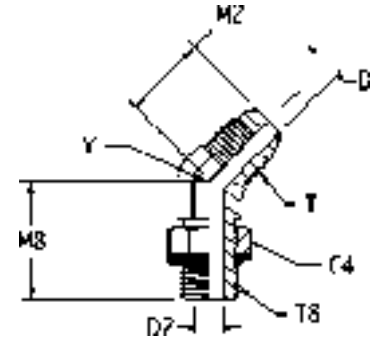

Tube O.D.		Thread Metric T8	Thread UN/UNF-2A T	C4 mm	D mm	D2 mm	M2 mm	M8 mm	Y mm	Weight (steel) g/1 piece	Triple-Lok® Steel	PN (bar)
mm	in.											
6	1/4	M10 x 1.0	7/16-20	13	4	5	18	27	11	23	4M10V8OMXS	250
6	1/4	M12 x 1.5	7/16-20	17	4	6	20	27	13	25	4M12V8OMXS	250
8	5/16	M12 x 1.5	1/2-20	17	6	6	20	28	13	28	5M12V8OMXS	250
10	3/8	M14 x 1.5	9/16-18	17	8	8	21	28	14	36	6M14V8OMXS	250
12	1/2	M16 x 1.5	3/4-16	19	10	9	25	33	19	68	8M16V8OMXS	250
12	1/2	M18 x 1.5	3/4-16	22	10	11	25	33	19	78	8M18V8OMXS	250
14, 15, 16	5/8	M22 x 1.5	7/8-14	27	12	14	28	38	22	119	10M22V8OMXS	250
18, 20	3/4	M27 x 2.0	1 1/16-12	32	16	18	33	46	27	208	12M27V8OMXS	175
25	1	M33 x 2.0	1 5/16-12	38	22	23	37	46	33	333	16M33V8OMXS	140

Triple-Lok® is delivered with NBR elastomeric seals as standard. For more details on other seal materials see page K93
 Order codes shown are part of our current manufacturing programme.
 Imperial and metric parts may vary in hexagon dimensions.

$$\frac{\text{PN (bar)}}{10} = \text{PN (MPa)}$$

VMTX 45° Male stud elbow

Triple-Lok® 37° Flare end / Male NPTF* thread (SAE 476)
SAE 070302 MS51508

*Stainless Steel = NPT to prevent galling

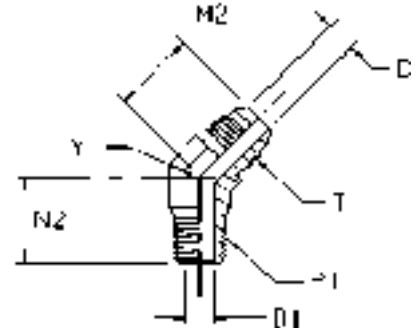

Tube O.D.		Thread NPT/NPTF PT	Thread UN/UNF-2A T	D mm	D1 mm	M2 mm	N2 mm	Y mm	Weight (steel) g/1 piece	Triple-Lok® Steel	Triple-Lok® Stainless Steel	Triple-Lok® Brass	PN (bar)
mm	in.												
6	3/16	1/8-27	3/8-24	3	5	18	14	11	15	3 VTX-S	3 VTX-SS	3 VTX-B	420
	1/4	1/8-27	7/16-20	4	5	18	16	11	18	4VMTXS	4 VTX-SS	4 VTX-B	420
	1/4	1/4-18	7/16-20	4	7	21	22	14	30	4-4VMTXS	4-4 VTX-SS	4-4 VTX-B	420
	5/16	1/8-27	1/2-20	6	5	20	16	13	22	5VMTXS	5 VTX-SS	5 VTX-B	420
8	5/16	1/4-18	1/2-20	6	7	21	22	14	31	5-4VMTXS	5-4 VTX-SS	5-4 VTX-B	420
10	3/8	1/4-16	9/16-18	8	7	21	22	14	27	6VMTXS	6 VTX-SS	6 VTX-B	420
	3/8	1/8-27	9/16-18	8	5	21	17	14	23	6-2 VTX-S	6-2 VTX-SS	6-2 VTX-B	420
	3/8	3/8-18	9/16-18	8	10	22	24	19	52	6-6 VTX-S	6-6 VTX-SS	6-6 VTX-B	420
	3/8	1/2-14	9/16-18	8	14	22	30	22	74	6-8VMTXS	6-8 VTX-SS	6-8 VTX-B	420
	1/2	1/4-16	3/4-16	10	7	25	24	19	62	8-4 VTX-S	8-4 VTX-SS	8-4 VTX-B	420
12	1/2	3/8-18	3/4-16	10	10	25	24	19	61	8 VTX-S	8 VTX-SS	8 VTX-B	420
	1/2	1/2-14	3/4-18	10	14	25	30	22	92	8-8VMTXS	8-8 VTX-SS	8-8 VTX-B	420
	1/2	3/4-14	3/4-18	10	18	26	31	27	144	8-12 VTX-S	8-12 VTX-SS	8-12 VTX-B	280
	5/8	1/2-14	7/8-14	12	14	28	30	22	92	10VMTXS	10 VTX-SS	10 VTX-B	350
14, 15, 16	5/8	3/8-18	7/8-14	12	10	28	25	22	94	10-6 VTX-S	10-6 VTX-SS	10-6 VTX-B	350
14, 15, 16	5/8	3/4-14	7/8-14	12	18	30	31	27	156	10-12VMTXS	10-12 VTX-SS		280
	3/4	3/4-14	1 1/16-12	16	18	33	31	27	148	12VMTXS	12 VTX-SS	12 VTX-B	280
18, 20	3/4	1/2-14	1 1/16-12	16	14	36	31	27	144	12-8VMTXS	12-8 VTX-SS	12-8 VTX-B	350
	3/4	1-11 1/2	1 1/16-12	16	24	36	38	33	169	12-16 VTX-S	12-16 VTX-SS	12-16 VTX-B	210
22	7/8	3/4-14	1 3/16-12	18	18	35	32	33	197	14 VTX-S	14 VTX-B		280
25	1	1-11 1/2	1 5/16-12	22	24	37	38	33	239	16VMTXS	16 VTX-SS	16 VTX-B	210
25	1	3/4-14	1 5/16-12	22	18	37	33	33	213	16-12 VTX-S	16-12 VTX-SS	16-12 VTX-B	280
28, 30, 32	1 1/4	1 1/4-11 1/2	1 5/8-12	28	32	40	42	41	385	20VMTXS	20 VTX-SS	20 VTX-B	170
35, 38	1 1/2	1 1/2-11 1/2	1 7/8-12	33	38	45	45	48	495	24 VTX-S	24 VTX-SS	24 VTX-B	170

Order codes shown are part of our current manufacturing programme.
Imperial and metric parts may vary in hexagon dimensions.

$$\frac{\text{PN (bar)}}{10} = \text{PN (MPa)}$$

Pressure ratings – PN shown, apply to Steel and Stainless Steel versions of the product.
For Brass parts reduce pressures by 35%

V3MX 45° Male stud elbow

Triple-Lok® 37° Flare end / Male BSPT thread (ISO 7)

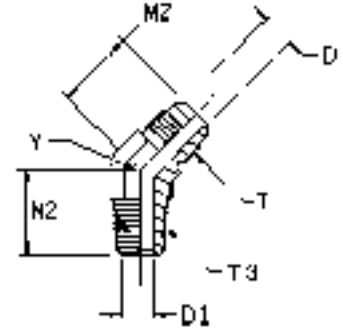

Tube O.D.		Thread BSPT T3	Thread UN/UNF-2A T	D mm	D1 mm	M2 mm	N2 mm	Y mm	Weight (steel) g/1 piece	Triple-Lok® Steel	PN (bar)
mm	in.										
6	1/4	1/8-27	7/16-20	4	5	18	16	11	18	4V3MXS	315
6	1/4	1/4-18	7/16-20	4	7	21	22	14	30	4-4V3MXS	315
8	5/16	1/8-27	1/2-20	6	5	20	16	13	22	5V3MXS	315
8	5/16	1/4-18	1/2-20	6	7	21	22	14	31	5-4V3MXS	315
10	3/8	1/4-16	9/16-18	8	7	21	22	14	27	6V3MXS	315
10	3/8	3/8-18	9/16-18	8	10	22	24	19	52	6-6V3MXS	315
10	3/8	1/2-14	9/16-18	8	14	22	30	22	74	6-8V3MXS	315
12	1/2	3/8-18	3/4-16	10	10	25	24	19	61	8V3MXS	315
12	1/2	1/2-14	3/4-16	10	14	25	30	22	92	8-8V3MXS	315
14, 15, 16	5/8	1/2-14	7/8-14	12	14	28	30	22	92	10V3MXS	315
18, 20	3/4	3/4-14	1 1/16-12	16	18	33	31	27	148	12V3MXS	160
25	1	1-11	1 5/16-12	22	24	37	38	33	239	16V3MXS	160
28, 30, 32	1 1/4	1 1/4-11	1 5/8-12	28	32	40	42	41	385	20V3MXS	160
35, 38	1 1/2	1 1/2-11	1 7/8-12	33	38	45	45	48	495	24V3MXS	160

Order codes shown are part of our current manufacturing programme. Imperial and metric parts may vary in hexagon dimensions.

$$\frac{\text{PN (bar)}}{10} = \text{PN (MPa)}$$

S87OMX Male stud branch tee

Triple-Lok® 37° Flare ends / Male metric thread O-ring (ISO 6149)

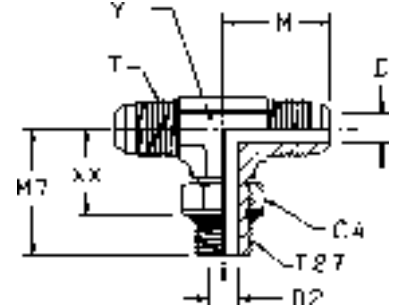

Tube O.D.		Thread Metric T87	Thread UN/UNF-2A T	C4 mm	D mm	D2 mm	M mm	M7 mm	XX mm	Y mm	Weight (steel) g/1 piece	Triple-Lok® Steel	PN (bar)
mm	in.												
6	1/4	M10 x 1.0	7/16-20	14	4	5	23	27	16	11	27	4M10S87OMXS	420
8	5/16	M12 x 1.5	1/2-20	17	6	6	24	31	19	13	42	5M12S87OMXS	420
10	3/8	M14 x 1.5	9/16-18	19	8	8	27	34	21	14	53	6M14S87OMXS	420
12	1/2	M16 x 1.5	3/4-16	22	10	9	32	38	24	19	113	8M16S87OMXS	350
12	1/2	M18 x 1.5	3/4-16	24	10	11	32	38	24	19	114	8M18S87OMXS	350
14, 15,16	5/8	M18 x 1.5	7/8-14	24	12	11	37	42	28	22	174	10M18S87OMXS	350
14, 15,16	5/8	M22 x 1.5	7/8-14	27	12	14	37	43	29	22	175	10M22S87OMXS	350
18, 20	3/4	M22 x 1.5	1 1/16-12	27	16	14	42	45	32	27	295	12M22S87OMXS	350
18, 20	3/4	M27 x 2.0	1 1/16-12	32	16	18	42	48	33	27	304	12M27S87OMXS	350
25	1	M27 x 2.0	1 5/16-12	32	22	18	46	53	36	33	491	16M27S87OMXS	280
25	1	M33 x 2.0	1 5/16-12	41	22	23	46	53	38	33	530	16M33S87OMXS	280

Triple-Lok® is delivered with NBR elastomeric seals as standard. For more details on other seal materials see page K93
Order codes shown are part of our current manufacturing programme.
Imperial and metric parts may vary in hexagon dimensions.

$$\frac{\text{PN (bar)}}{10} = \text{PN (MPa)}$$

S50MX Male stud branch tee

Triple-Lok® 37° Flare ends / Male UNF thread O-ring (ISO 11926)
SAE 070429 MS51529

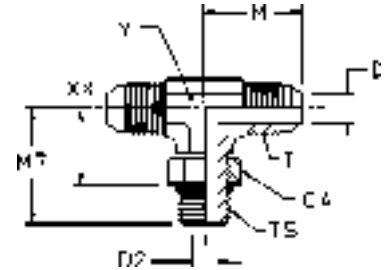

Tube O.D.		Thread UN/UNF-2A T5	Thread UN/UNF-2A T	C4 mm	D mm	D2 mm	M mm	M7 mm	XX mm	Y mm	Weight (steel) g/1 piece	Triple-Lok® Steel	Triple-Lok® Stainless Steel	PN (bar)
6	1/4	7/16-20	7/16-20	14	4	5	23	26	16	11	46	4S50MXS	4 S50X-SS	420
8	5/16	1/2-20	1/2-20	16	6	6	25	29	18	14	66	5 S50X-S	5 S50X-SS	420
10	3/8	9/16-18	9/16-18	17	8	8	27	32	21	14	76	6S50MXS	6 S50X-SS	420
12	1/2	3/4-16	3/4-16	22	10	10	32	37	24	19	150	8S50MXS	8 S50X-SS	420
14, 15, 16	5/8	7/8-14	7/8-14	27	12	13	37	43	29	22	224	10S50MXS	10 S50X-SS	350
18, 20	3/4	1 1/16-12	1 1/16-12	32	16	16	42	49	33	27	367	12 S50X-S	12 S50X-SS	350
25	1	1 5/16-12	1 5/16-12	38	22	22	46	52	36	33	506	16 S50X-S	16 S50X-SS	280
28, 30, 32	1 1/4	1 5/8-12	1 5/8-12	48	28	28	52	57	41	42	1053	20 S50X-S	20 S50X-SS	280
35, 38	1 1/2	1 7/8-12	1 7/8-12	55	34	34	59	61	44	48	1296	24 S50X-S		210
	2	2 1/2-12	2 1/2-12	70	45	45	78	73	57	66	2000	32 S50X-S		140

Triple-Lok® is delivered with NBR elastomeric seals as standard. For more details on other seal materials see page K93
Order codes shown are part of our current manufacturing programme.
Imperial and metric parts may vary in hexagon dimensions.

$$\frac{\text{PN (bar)}}{10} = \text{PN (MPa)}$$

Pressure ratings – PN shown, apply to Steel and Stainless Steel versions of the product.

S4OMX Male stud branch tee

Triple-Lok® 37° Flare end / Adjustable BSPP thread O-ring + retaining ring (ISO 1179)

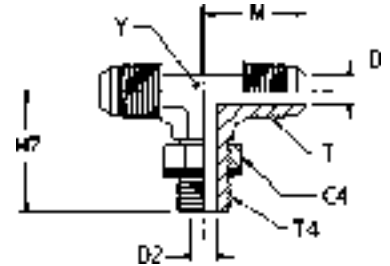

Tube O.D.		Thread BSPP T4	Thread UN/UNF-2A T	C4 mm	D mm	D2 mm	M mm	M7 mm	Y mm	Weight (steel) g/1 piece	Triple-Lok® Steel	Triple-Lok® Stainless Steel	PN (bar)
mm	in.												
6	1/4	1/8-28	7/16-20	14	4	4	23	27	11	47	4S4OMXS	4S4OMXS	250
10	3/8	1/4-19	9/16-18	19	8	8	27	32	14	78	6S4OMXS	6S4OMXS	250
12	1/2	3/8-19	3/4-16	22	10	10	32	37	19	154	8S4OMXS	8S4OMXS	250
12	1/2	1/2-14	3/4-16	27	10	12	34	44	22	186	8-8-8S4OMXS	8-8-8S4OMXS	250
14, 15, 16	5/8	1/2-14	7/8-14	27	12	12	37	43	22	231	10S4OMXS	10S4OMXS	250
18, 20	3/4	3/4-14	1 1/16-12	36	16	16	42	50	27	379	12S4OMXS	12S4OMXS	250
25	1	1-11	1 5/16-12	41	22	22	46	52	33	569	16S4OMXS	16S4OMXS	250
28, 30, 32	1 1/4	1 1/4-11	1 5/8-12	50	28	28	52	57	41	1075	20S4OMXS	20S4OMXS	210

Triple-Lok® is delivered with NBR elastomeric seals as standard. For more details on other seal materials see page K93
Order codes shown are part of our current manufacturing programme.
Imperial and metric parts may vary in hexagon dimensions.

$$\frac{\text{PN (bar)}}{10} = \text{PN (MPa)}$$

Pressure ratings – PN shown, apply to Steel and Stainless Steel versions of the product.

K

S8OMX Male stud branch tee

Triple-Lok® 37° Flare ends / Male metric thread – O-ring + retaining ring

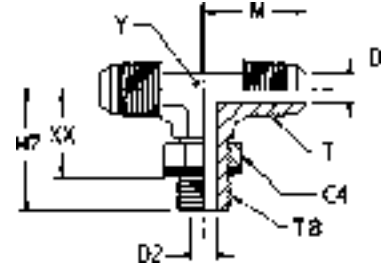

Tube O.D. mm	Tube O.D. in.	Thread Metric T8	Thread UN/UNF-2A T	C4 mm	D mm	D2 mm	M mm	M7 mm	XX mm	Y mm	Weight (steel) g/1 piece	Triple-Lok® Steel	PN (bar)
6	1/4	M10 x 1.0	7/16-20	13	4	5	23	27	17	11	27	4M10S8OMXS	250
8	5/16	M12 x 1.5	1/2-20	17	6	6	24	31	20	13	42	5M12S8OMXS	250
10	3/8	M14 x 1.5	9/16-18	17	8	8	27	34	22	14	53	6M14S8OMXS	250
12	1/2	M16 x 1.5	3/4-16	19	10	9	32	38	24	19	95	8M16S8OMXS	250
12	1/2	M18 x 1.5	3/4-16	22	10	11	32	38	26	19	114	8M18S8OMXS	250
14, 15, 16	5/8	M22 x 1.5	7/8-14	27	12	14	37	43	30	22	175	10M22S8OMXS	250
18, 20	3/4	M27 x 2.0	1 1/16-12	32	16	18	42	48	35	27	304	12M27S8OMXS	175
25	1	M33 x 2.0	1 5/16-12	38	22	23	46	53	38	33	491	16M33S8OMXS	140

Triple-Lok® is delivered with NBR elastomeric seals as standard. For more details on other seal materials see page K93
 Order codes shown are part of our current manufacturing programme.
 Imperial and metric parts may vary in hexagon dimensions.

$$\frac{\text{PN (bar)}}{10} = \text{PN (MPa)}$$

SMTX Male stud branch tee

Triple-Lok® 37° Flare ends / Male NPTF* thread (SAE 476)
SAE 070425 MS51512

*Stainless Steel = NPT to prevent galling

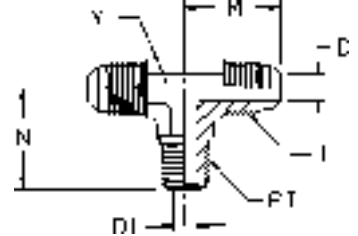

Tube O.D.	Thread NPT/NPTF PT	Thread UN/UNF-2A T	D mm	D1 mm	M mm	N mm	Y mm	Weight (steel) g/1 piece	Triple-Lok®			PN (bar)
									Steel	Stainless Steel	Brass	
6	3/16	1/8-27	3	5	21	18	11	25	3 STX-S	3 STX-SS	3 STX-B	420
	1/4	1/8-27	4	5	23	20	11	31	4 STX-S	4 STX-SS	4 STX-B	420
	1/4	1/4-18	4	7	27	28	14	49	4-4-4 STX-S	4-4-4 STX-SS	4-4-4 STX-B	420
	5/16	1/8-27	6	5	24	20	14	37	5 STX-S	5 STX-SS	5 STX-B	420
10	3/8	1/4-16	8	7	27	28	14	57	6SMTXS	6 STX-SS	6 STX-B	420
10	3/8	3/8-18	8	10	29	31	19	77	6-6-6 STX-S	6-6-6 STX-SS	6-6-6 STX-B	420
12	1/2	3/8-18	10	10	32	31	19	113	8 STX-S	8 STX-SS	8 STX-B	420
12	1/2	1/2-14	10	14	34	37	22	164	8-8-8 STX-S	8-8-8 STX-SS	8-8-8 STX-B	420
14, 15, 16	5/8	1/2-14	12	14	37	37	22	173	10 STX-S	10 STX-SS	10 STX-B	350
18, 20	3/4	3/4-14	16	18	42	40	27	272	12 STX-S	12 STX-SS	12 STX-B	280
22	7/8	3/4-14	18	18	46	43	33	323	14 STX-S			280
25	1	1-11 1/2	21	24	46	50	33	413	16 STX-S	16 STX-SS	16 STX-B	210
28, 30, 32	1 1/4	1 1/4-11 1/2	27	32	52	61	41	681	20 STX-S	20 STX-SS	20 STX-B	170
	2	1 1/2-11 1/2	33	38	34	67	48	905	24 STX-S	24 STX-SS	24 STX-B	170

Order codes shown are part of our current manufacturing programme.
Imperial and metric parts may vary in hexagon dimensions.

$$\frac{\text{PN (bar)}}{10} = \text{PN (MPa)}$$

Pressure ratings – PN shown, apply to Steel and Stainless Steel versions of the product.
For Brass parts reduce pressures by 35%

S3MX Male stud branch tee

Triple-Lok® 37° Flare ends / Male BSPT thread (ISO 7)

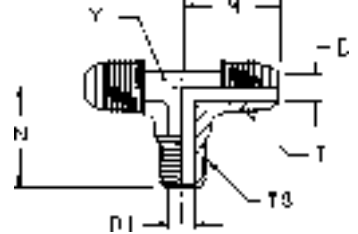

Tube O.D.		Thread BSPT T3	Thread UN/UNF-2A T	D mm	D1 mm	M mm	N mm	Y mm	Weight (steel) g/1 piece	Triple-Lok® Steel	Triple-Lok® Stainless Steel	PN (bar)
mm	in.											
6	1/4	1/8-28	7/16-20	4	5	23	20	11	30	4S3MXS	4S3MXSS	315
10	3/8	1/4-19	9/16-18	8	7	27	28	14	55	6S3MXS	6S3MXSS	315
12	1/2	3/8-19	3/4-16	10	10	32	31	19	111	8S3MXS	8S3MXSS	315
14, 15, 16	5/8	1/2-14	7/8-14	12	14	37	37	22	169	10S3MXS	10S3MXSS	315
18, 20	3/4	3/4-14	1 1/16-12	16	18	42	40	27	267	12S3MXS	12S3MXSS	160
25	1	1-11	1 5/16-12	22	24	46	50	33	407	16S3MXS	16S3MXSS	160

Order codes shown are part of our current manufacturing programme.
Imperial and metric parts may vary in hexagon dimensions.

$$\frac{\text{PN (bar)}}{10} = \text{PN (MPa)}$$

Pressure ratings – PN shown, apply to Steel and Stainless Steel versions of the product.

R87OMX Male stud run tee

Triple-Lok® 37° Flare ends / Male metric thread – O-ring (ISO 6149)

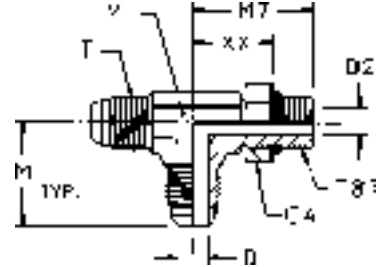

Tube O.D. mm	Tube O.D. in.	Thread Metric T87	Thread UN/UNF-2A T	C4 mm	D mm	D2 mm	M mm	M7 mm	XX mm	Y mm	Weight (steel) g/1 piece	Triple-Lok® Steel	PN (bar)
6	1/4	M10 x 1.0	7/16-20	14	4	5	23	27	16	11	27	4M10R87OMXS	420
10	3/8	M14 x 1.5	9/16-18	19	8	8	27	34	21	14	53	6M14R87OMXS	420
10	3/8	M18 x 1.5	9/16-18	24	8	11	29	38	24	19	90	6M18R87OMXS	350
12	1/2	M16 x 1.5	3/4-16	22	10	9	32	38	24	19	113	8M16R87OMXS	350
12	1/2	M18 x 1.5	3/4-16	24	10	11	32	37	24	19	114	8M18R87OMXS	350
14, 15, 16	5/8	M18 x 1.5	7/8-14	24	12	11	37	42	29	22	174	10M18R87OMXS	350
14, 15, 16	5/8	M22 x 1.5	7/8-14	27	12	14	37	43	29	22	175	10M22R87OMXS	350
18, 20	3/4	M22 x 1.5	1 1/16-12	27	16	14	42	45	32	27	295	12M22R87OMXS	350
18, 20	3/4	M27 x 2.0	1 1/16-12	32	16	18	42	51	33	27	315	12M27R87OMXS	350
25	1	M33 x 2.0	1 5/16-12	41	22	23	46	53	40	33	495	16M33R87OMXS	280

Triple-Lok® is delivered with NBR elastomeric seals as standard. For more details on other seal materials see page K93
Order codes shown are part of our current manufacturing programme.
Imperial and metric parts may vary in hexagon dimensions.

$\frac{\text{PN (bar)}}{10} = \text{PN (MPa)}$

K

R50MX Male stud run tee

Triple-Lok® 37° Flare ends / Male UNF thread O-ring (ISO 11926)
 SAE 070428 MS51530

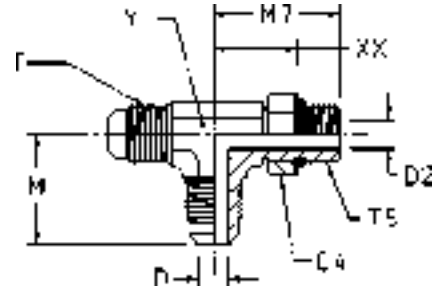

Tube O.D.		Thread UN/UNF-2A T5	Thread UN/UNF-2A T	C4 mm	D mm	D2 mm	M mm	M7 mm	XX mm	Y mm	Weight (steel) g/1 piece	Triple-Lok® Steel	Triple-Lok® Stainless Steel	PN (bar)
6	1/4	7/16-20	7/16-20	14	4	4	23	26	16	11	46	4 R50X-S	4 R50X-SS	420
8	5/16	1/2-20	1/2-20	16	6	6	25	29	18	14	66	5 R50X-S	5 R50X-SS	420
10	3/8	9/16-18	9/16-18	17	8	8	27	32	21	14	76	6R50MXS	6 R50X-SS	420
12	1/2	3/4-16	3/4-16	22	10	10	32	37	24	19	151	8R50MXS	8 R50X-SS	420
14, 15, 16	5/8	7/8-14	7/8-14	25	12	12	37	43	29	22	226	10 R50X-S	10 R50X-SS	350
18, 20	3/4	1 1/16-12	1 1/16-12	32	16	16	42	49	33	27	372	12 R50X-S	12 R50X-SS	350
25	1	1 5/16-12	1 5/16-12	38	22	22	46	52	36	33	557	16 R50X-S	16 R50X-SS	280
28, 30, 32	1 1/4	1 5/8-12	1 5/8-12	48	28	28	52	57	41	41	1053	20 R50X-S	20 R50X-SS	280
35, 38	1 1/2	1 7/8-12	1 7/8-12	54	33	33	59	61	44	48	1296	24 R50X-S	24 R50X-SS	210
	2	2 1/2-12	2 1/2-12	70	45	45	78	73	57	66	2000	32 R50X-S	32 R50X-SS	140

Triple-Lok® is delivered with NBR elastomeric seals as standard. For more details on other seal materials see page K93
 Order codes shown are part of our current manufacturing programme.
 Imperial and metric parts may vary in hexagon dimensions.

$$\frac{\text{PN (bar)}}{10} = \text{PN (MPa)}$$

Pressure ratings – PN shown, apply to Steel and Stainless Steel versions of the product.

R4OMX Male stud run tee

Triple-Lok® 37° Flare end / Adjustable BSPP thread O-ring + retaining ring (ISO 1179)

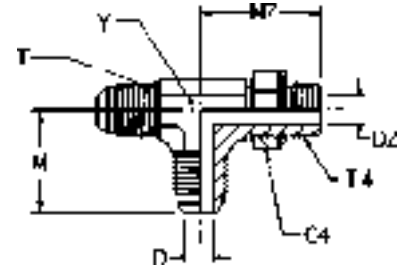

Tube O.D.		Thread BSPP T4	Thread UN/UNF-2A T	C4 mm	D mm	D2 mm	M mm	M7 mm	Y mm	Weight (steel) g/1 piece	Triple-Lok® Steel	Triple-Lok® Stainless Steel	PN (bar)
mm	in.												
6	1/4	1/8-28	7/16-20	14	4	4	23	27	11	47	4R4OMXS	4R4OMXSS	250
10	3/8	1/4-19	9/16-18	19	8	8	27	32	14	78	6R4OMXS	6R4OMXSS	250
12	1/2	3/8-19	3/4-16	22	10	10	32	37	19	154	8R4OMXS	8R4OMXSS	250
14, 15, 16	5/8	1/2-14	7/8-14	27	12	12	37	43	22	231	10R4OMXS	10R4OMXSS	250
18, 20	3/4	3/4-14	1 1/16-12	36	16	16	42	50	27	379	12R4OMXS	12R4OMXSS	250
25	1	1-11	1 5/16-12	41	22	22	46	52	33	569	16R4OMXS	16R4OMXSS	250
28, 30, 32	1 1/4	1 1/4-11	1 5/8-12	50	28	28	52	57	41	1075	20R4OMXS	20R4OMXSS	210

Triple-Lok® is delivered with NBR elastomeric seals as standard. For more details on other seal materials see page K93
 Order codes shown are part of our current manufacturing programme.
 Imperial and metric parts may vary in hexagon dimensions.

$$\frac{\text{PN (bar)}}{10} = \text{PN (MPa)}$$

Pressure ratings – PN shown, apply to Steel and Stainless Steel versions of the product.

K

R8OMX Male stud run tee

Triple-Lok® 37° Flare ends / Male metric thread – O-ring + retaining ring

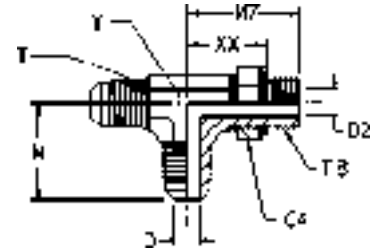

Tube O.D. mm	Tube O.D. in.	Thread Metric T87	Thread UN/UNF-2A T	C4 mm	D mm	D2 mm	M mm	M7 mm	XX mm	Y mm	Weight (steel) g/1 piece	Triple-Lok® Steel	PN (bar)
6	1/4	M10 x 1.0	7/16-20	13	4	5	23	27	17	11	27	4M10R8OMXS	250
8	5/16	M12 x 1.5	1/2-20	17	6	6	24	31	20	13	42	5M12R8OMXS	250
10	3/8	M14 x 1.5	9/16-18	17	8	8	27	34	22	14	53	6M14R8OMXS	250
12	1/2	M16 x 1.5	3/4-16	19	10	9	32	38	24	19	95	8M16R8OMXS	250
12	1/2	M18 x 1.5	3/4-16	22	10	10	32	37	26	19	114	8M18R8OMXS	250
14, 15, 16	5/8	M22 x 1.5	7/8-14	27	12	14	37	43	30	22	175	10M22R8OMXS	250
18, 20	3/4	M27 x 2.0	1 1/16-12	32	16	18	42	51	35	27	304	12M27R8OMXS	175
25	1	M33 x 2.0	1 5/16-12	38	22	23	46	53	38	33	491	16M33R8OMXS	140

Triple-Lok® is delivered with NBR elastomeric seals as standard. For more details on other seal materials see page K93
 Order codes shown are part of our current manufacturing programme.
 Imperial and metric parts may vary in hexagon dimensions.

$$\frac{\text{PN (bar)}}{10} = \text{PN (MPa)}$$

RMTX Male stud run tee

Triple-Lok® 37° Flare ends / Male NPTF* thread (SAE 476)
 SAE 070424 MS51511

*Stainless Steel = NPT to prevent galling

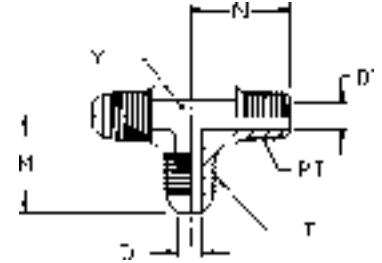

Tube O.D.	mm	in.	Thread NPT/NPTF PT	Thread UN/UNF-2A T	D mm	D1 mm	M mm	N mm	Y mm	Weight (steel) g/1 piece	Triple-Lok®	Triple-Lok®	Triple-Lok®	PN (bar)
											Steel	Stainless Steel	Brass	
6		3/16	1/8-27	3/8-24	3	5	21	18	11	25	3 RTX-S	3 RTX-SS		420
		1/4	1/8-27	7/16-20	4	5	23	20	11	31	4 RTX-S	4 RTX-SS	4 RTX-B	420
		1/4	1/4-18	7/16-20	4	7	27	28	14	49	4-4-4 RTX-S	4-4-4 RTX-SS	4-4-4 RTX-B	420
		5/16	1/8-27	1/2-20	6	5	25	21	14	37	5 RTX-S	5 RTX-SS	5 RTX-B	420
10		3/8	1/4-16	9/16-18	8	7	27	28	14	57	6 RTX-S	6 RTX-SS	6 RTX-B	420
10		3/8	3/8-18	9/16-18	8	10	29	31	19	77	6-6-6 RTX-S	6-6-6 RTX-SS	6-6-6 RTX-B	420
12		1/2	3/8-18	3/4-16	10	10	32	31	19	109	8 RTX-S	8 RTX-SS	8 RTX-B	420
12		1/2	1/2-14	3/4-16	10	14	34	37	22	163	8-8-8RMTXS	8-8-8 RTX-SS	8-8-8 RTX-B	420
14, 15, 16		5/8	1/2-14	7/8-14	12	14	37	37	22	172	10 RTX-S	10 RTX-SS	10 RTX-B	350
18, 20		3/4	3/4-14	1 1/16-12	16	18	42	40	27	268	12 RTX-S	12 RTX-SS	12 RTX-B	280
22		7/8	3/4-14	1 3/16-12	18	18	46	43	33	323	14 RTX-S			280
25		1	1-11 1/2	1 5/16-12	21	24	46	50	33	413	16 RTX-S	16 RTX-SS	16 RTX-B	210
28, 30, 32		1 1/4	1 1/4-11 1/2	1 5/8-12	27	32	52	61	41	681	20 RTX-S	20 RTX-SS	20 RTX-B	170
35, 38		1 1/2	1 1/2-11 1/2	1 7/8-12	33	38	59	67	48	905	24 RTX-S	24 RTX-SS		170

Order codes shown are part of our current manufacturing programme.
 Imperial and metric parts may vary in hexagon dimensions.

$$\frac{\text{PN (bar)}}{10} = \text{PN (MPa)}$$

Pressure ratings – PN shown, apply to Steel and Stainless Steel versions of the product.
 For Brass parts reduce pressures by 35%



R3MX Male stud run tee

Triple-Lok® 37° Flare ends / Male BSPT thread (ISO 7)

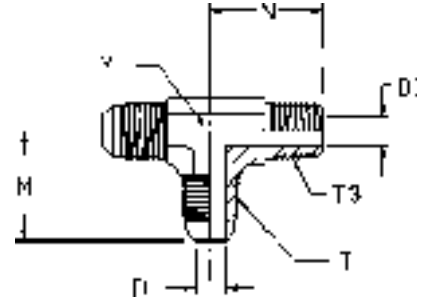

Tube O.D.		Thread BSPT T3	Thread UN/UNF-2A T	D mm	D1 mm	M mm	N mm	Y mm	Weight (steel) g/1 piece	Triple-Lok® Steel	Triple-Lok® Stainless Steel	PN (bar)
mm	in.											
6	1/4	1/8-28	7/16-20	4	5	23	20	11	30	4R3MXS	4R3MXSS	315
8	5/16	1/8-28	1/2-20	6	5	24	20	13	36	5R3MXS	5R3MXSS	315
10	3/8	1/4-19	9/16-18	8	7	27	28	14	55	6R3MXS	6R3MXSS	315
12	1/2	3/8-19	3/4-16	10	10	32	31	19	107	8R3MXS	8R3MXSS	315
14, 15, 16	5/8	1/2-14	7/8-14	12	14	37	37	22	170	10R3MXS	10R3MXSS	315

Order codes shown are part of our current manufacturing programme.
Imperial and metric parts may vary in hexagon dimensions.

$$\frac{\text{PN (bar)}}{10} = \text{PN (MPa)}$$

Pressure ratings – PN shown, apply to Steel and Stainless Steel versions of the product.

G4MX Female connector

Triple-Lok® 37° Flare end / Female BSPP thread (ISO 1179-1)

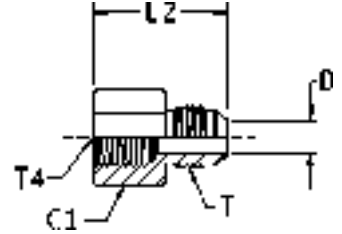

Tube O.D.		Thread BSPP T4	Thread UN/UNF-2A T	C1 mm	D mm	L2 mm	Weight (steel) g/1 piece	Triple-Lok® Steel	Triple-Lok® Stainless Steel	PN (bar)
mm	in.									
6	1/4	1/8-28	7/16-20	16	4	30	15	4G4MXS	4G4MXSS	315
6	1/4	1/4-19	7/16-20	19	4	35	42	4-4G4MXS	4-4G4MXSS	400
8	5/16	1/8-28	1/2-20	16	6	30	22	5G4MXS	5G4MXSS	315
8	5/16	1/4-19	1/2-20	19	6	35	40	5-4G4MXS	5-4G4MXSS	400
10	3/8	1/4-19	9/16-18	19	8	36	40	6G4MXS	6G4MXSS	400
10	3/8	3/8-19	9/16-18	22	8	37	50	6-6G4MXS	6-6G4MXSS	350
12	1/2	3/8-19	3/4-16	22	10	40	64	8G4MXS	8G4MXSS	350
12	1/2	1/2-14	3/4-16	30	10	46	116	8-8G4MXS	8-8G4MXSS	400
14, 15, 16	5/8	1/2-14	7/8-14	30	12	48	121	10G4MXS	10G4MXSS	350
18, 20	3/4	3/4-14	1 1/16-12	36	16	52	188	12G4MXS	12G4MXSS	315
25	1	1 1/16	1 5/16-12	46	22	60	340	16G4MXS	16G4MXSS	280
28, 30, 32	1 1/4	1 1/4-11	1 5/8-12	50	28	63	438	20G4MXS	20G4MXSS	210
35, 38	1 1/2	1 1/2-11	1 7/8-12	55	33	67	526	24G4MXS	24G4MXSS	140

Order codes shown are part of our current manufacturing programme.
Imperial and metric parts may vary in hexagon dimensions.

$$\frac{\text{PN (bar)}}{10} = \text{PN (MPa)}$$

Pressure ratings – PN shown, apply to Steel and Stainless Steel versions of the product.

GMTX Female connector

Triple-Lok® 37° Flare end / Female NPTF* thread (SAE J476)

SAE 070103 MS51503

*Stainless Steel = NPT to prevent galling

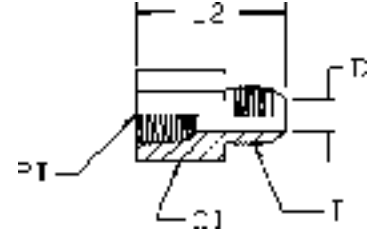

Tube O.D. mm	Tube O.D. in.	Thread NPT/NPTF PT	Thread UN/UNF-2A T	C1 mm	D mm	L2 mm	Weight (steel) g/1 piece	Triple-Lok® Steel	Triple-Lok® Stainless Steel	PN (bar)
6	1/4	1/8-27	7/16-20	14	4	30	42	4 GTX-S	4GMTXSS	420
6	1/4	1/4-18	7/16-20	19	4	36	40	4-4GMTXS	4-4GMTXSS	420
6	1/4	3/8-18	7/16-20	22	5	37	40	4-6 GTX-S	4-6GMTXSS	420
6	1/4	1/2-14	7/16-20	29	5	37	42	4-8 GTX-S	4-8GMTXSS	350
8	5/16	1/8-27	1/2-20	14	6	30	40	5 GTX-S	5GMTXSS	420
8	5/16	1/4-18	1/2-20	19	6	35	42	5-4 GTX-S	5-4GMTXSS	420
10	3/8	1/4-18	9/16-18	19	8	36	40	6GMTXS	6GMTXSS	420
10	3/8	3/8-18	9/16-18	22	8	37	62	6-6 GTX-S	6-6GMTXSS	420
10	3/8	1/2-14	9/16-18	29	8	45	90	6-8 GTX-S	6-8GMTXSS	350
12	1/2	3/8-18	3/4-16	22	10	40	45	8 GTX-S	8GMTXSS	420
12	1/2	1/4-18	3/4-16	21	10	36	80	8-4 GTX-S	8-4GMTXSS	420
12	1/2	1/2-14	3/4-16	29	10	46	116	8-8 GTX-S	8-8GMTXSS	350
12	1/2	3/4-14	3/4-16	35	10	48	150	8-12 GTX-S	8-12GMTXSS	280
14, 15,16	5/8	1/2-14	7/8-14	29	12	48	121	10 GTX-S	10GMTXSS	350
14, 15,16	5/8	3/4-14	7/8-14	35	13	51	182	10-12 GTX-S	10-12GMTXSS	280
18, 20	3/4	3/4-14	1 1/16-12	35	16	52	188	12 GTX-S	12GMTXSS	280
18, 20	3/4	1/2-14	1 1/16-12	29	16	49	133	12-8 GTX-S	12-8GMTXSS	350
22	7/8	3/4-14	1 3/16-12	35	18	52	201	14 GTX-S	14GMTXSS	210
25	1	1-11 1/2	1 5/16-12	41	22	59	280	16 GTX-S	16GMTXSS	210
28, 30, 32	1 1/4	1 1/4-11 1/2	1 5/8-12	51	27	63	408	20 GTX-S	20GMTXSS	170
35, 38	1 1/2	1 1/2-11 1/2	1 7/8-12	60	33	67	370	24 GTX-S	24GMTXSS	140
	2	2-11 1/2	2 1/2-12	73	44	75	1262	32 GTX-S		140

Order codes shown are part of our current manufacturing programme.
Imperial and metric parts may vary in hexagon dimensions.

$$\frac{\text{PN (bar)}}{10} = \text{PN (MPa)}$$

Pressure ratings – PN shown, apply to Steel and Stainless Steel versions of the product.

WGMTX Female bulkhead connector

Triple-Lok® 37° Flare end / Female NPTF* thread (SAE J476)

*Stainless Steel = NPT to prevent galling

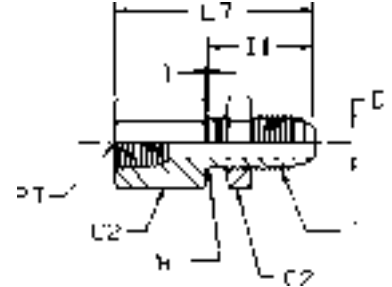

Tube O.D. mm	Tube O.D. in.	Thread NPT/NPTF PT	Thread UN/UNF-2A T	C2 mm	D mm	I1 mm	L7 mm	W mm	Weight (steel) g/1 piece	Triple-Lok® Steel	Triple-Lok® Stainless Steel	PN (bar)
6	1/4	1/8-27	7/16-20	17	4	31	47	11	42	4 WGTX-S	4WGMTXSS	420
6	1/4	1/4-18	7/16-20	19	4	34	54	11	62	4-4 WGTX-S	4-4WGMTXSS	420
10	3/8	1/4-18	9/16-18	21	8	33	52	14	72	6 WGTX-S	6WGMTXSS	420
12	1/2	3/8-18	3/4-16	25	10	37	59	19	117	8 WGTX-S	8WGMTXSS	420
14, 15, 16	5/8	1/2-14	7/8-14	29	12	40	68	22	179	10 WGTX-S	10WGMTXSS	350
18, 20	3/4	3/4-14	1 1/16-12	35	16	45	74	27	284	12 WGTX-S	12WGMTXSS	280
25	1	1-11 1/2	1 5/16-12	41	21	45	79	33	415	16 WGTX-S	16WGMTXSS	210

Order codes shown are part of our current manufacturing programme.
Imperial and metric parts may vary in hexagon dimensions.

$$\frac{\text{PN (bar)}}{10} = \text{PN (MPa)}$$

Pressure ratings – PN shown, apply to Steel and Stainless Steel versions of the product.

K

Maximum bulkhead wallthickness

Size	Tube O.D.		Straight bulkhead union Max. thickness mm	Shape bulkhead union Max. thickness mm
	inch	metric		
4	1/4	6	8.4	5.3
5	5/16	8	8.4	5.3
6	3/8	10	10.7	7.1
8	1/2	12	11.2	8.4
10	5/8	14–16	10.9	8.1
12	3/4	18–20	11.2	8.6
14	7/8		10.4	7.9
16	1	22–25	9.9	7.4
20	1 1/4	28–32	10.2	7.4
24	1 1/2	35–38	7.1	—
32	2		7.1	—

DMTX Female elbow connector

Triple-Lok® 37° Flare end / Female NPTF* thread (SAE J476)

SAE 070203 MS51506

*Stainless Steel = NPT to prevent galling

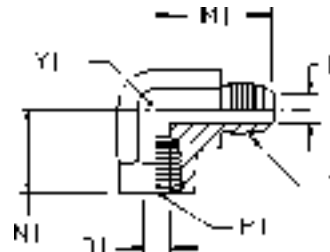

Tube O.D.		Thread NPT/NPTF PT	Thread UN/UNF-2A T	D mm	D1 mm	M1 mm	N1 mm	Y1 mm	Weight (steel) g/1 piece	Triple-Lok® Steel	Triple-Lok® Stainless Steel	Triple-Lok® Brass	PN (bar)
mm	in.												
6	1/4	1/8-27	7/16-20	4	8	27	17	14	33	4 DTX-S	4 DTX-SS	4 DTX-B	350
6	1/4	1/4-18	7/16-20	4	11	31	22	19	70	4-4 DTX-S	4-4 DTX-SS	4-4 DTX-B	350
8	5/16	1/8-27	1/2-20	6	8	27	17	14	33	5 DTX-S	5 DTX-SS	5 DTX-B	350
8	5/16	1/4-18	1/2-20	6	11	29	22	19	67	5-4 DTX-S	5-4 DTX-SS	5-4 DTX-B	350
10	3/8	1/4-18	9/16-18	8	11	31	22	19	67	6 DTX-S	6 DTX-SS	6 DTX-B	350
10	3/8	1/8-27	9/16-18	8	8	31	17	14	39	6-2 DTX-S	6-2 DTX-SS	6-2 DTX-B	350
10	3/8	3/8-18	9/16-18	8	14	33	26	22	103	6-6 DTX-S	6-6 DTX-SS	6-6 DTX-B	310
12	1/2	3/8-18	3/4-16	10	14	36	26	22	115	8 DTX-S	8 DTX-SS	8 DTX-B	310
12	1/2	1/4-18	3/4-16	10	11	36	26	19	190	8-4 DTX-S	8-4 DTX-SS	8-4 DTX-B	350
12	1/2	1/2-14	3/4-16	10	18	39	31	27	178	8-8DMTXS	8-8 DTX-SS	8-8 DTX-B	210
14, 15, 16	5/8	1/2-14	7/8-14	12	18	42	31	27	180	10 DTX-S	10 DTX-SS	10 DTX-B	210
18, 20	3/4	3/4-14	1 1/16-12	16	23	48	35	33	315	12DMTXS	12 DTX-SS	12 DTX-B	210
18, 20	3/4	1/2-14	1 1/16-12	16	18	48	34	27	175	12-8 DTX-S	12-8 DTX-SS	12-8 DTX-B	210
22	7/8	3/4-14	1 3/16-12	18	23	47	36	33	285	14 DTX-S	14 DTX-SS		125
25	1	1-11 1/2	1 5/16-12	21	29	55	41	41	506	16 DTX-S	16 DTX-SS	16 DTX-B	125
28, 30, 32	1 1/4	1 1/4-11 1/2	1 5/8-12	27	37	59	43	48	619	20 DTX-S	20 DTX-SS	20 DTX-B	100
35, 38	1 1/2	1 1/2-11 1/2	1 7/8-12	33	43	73	53	64	1725	24 DTX-S	24 DTX-SS		100

Order codes shown are part of our current manufacturing programme.
Imperial and metric parts may vary in hexagon dimensions.

$$\frac{\text{PN (bar)}}{10} = \text{PN (MPa)}$$

Pressure ratings – PN shown, apply to Steel and Stainless Steel versions of the product.
For Brass parts reduce pressures by 35%

OTX Female branch tee

Triple-Lok® 37° Flare ends / Female NPTF* thread (SAE J476)
SAE 070427 MS51513

*Stainless Steel = NPT to prevent galling

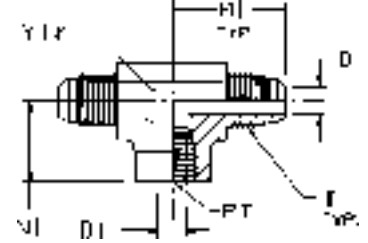

Tube O.D.		Thread NPT/NPTF PT	Thread UN/UNF-2A T	D mm	D1 mm	M1 mm	N1 mm	Y1 mm	Weight (steel) g/1 piece	Triple-Lok® Steel	Triple-Lok® Stainless Steel	Triple-Lok® Brass	PN (bar)
mm	in.												
6	1/4	1/8-27	7/16-20	4	8	27	17	14	53	4 OTX-S	4 OTX-SS	4 OTX-B	350
6	1/4	1/4-18	7/16-20	4	11	29	22	19	90	4-4-4 OTX-S	4-4-4 OTX-SS	4-4-4 OTX-B	350
8	5/16	1/8-27	1/2-20	6	8	27	17	14	53	5 OTX-S	5 OTX-SS	5 OTX-B	350
10	3/8	1/4-18	9/16-18	8	11	32	22	19	98	6 OTX-S	6 OTX-SS	6 OTX-B	350
12	1/2	3/8-18	3/4-16	10	14	36	26	22	145	8 OTX-S	8 OTX-SS	8 OTX-B	310
14, 15, 16	5/8	1/2-14	7/8-14	12	18	42	32	27	240	10 OTX-S	10 OTX-SS	10 OTX-B	210
18, 20	3/4	3/4-14	1 1/16-12	16	23	48	35	33	390	12 OTX-S	12 OTX-SS	12 OTX-B	210
25	1	1-11 1/2	1 5/16-12	21	29	55	41	41	745	16 OTX-S	16 OTX-SS	16 OTX-B	125
28, 30, 32	1 1/4	1 1/4-11 1/2	1 5/8-12	27	37	59	43	48	930	20 OTX-S	20 OTX-SS		100
35, 38	1 1/2	1 1/2-11 1/2	1 7/8-12	33	43	73	53	64	2255	24 OTX-S	24 OTX-SS		100

Order codes shown are part of our current manufacturing programme.
Imperial and metric parts may vary in hexagon dimensions.

$$\frac{\text{PN (bar)}}{10} = \text{PN (MPa)}$$

Pressure ratings – PN shown, apply to Steel and Stainless Steel versions of the product.
For Brass parts reduce pressures by 35%

K

MTX Female run tee

Triple-Lok® 37° Flare ends / Female NPTF* thread (SAE J476)

SAE 070426 MS51514

*Stainless Steel = NPT to prevent galling



Tube O.D.		Thread NPT/NPTF PT	Thread UN/UNF-2A T	D mm	D1 mm	M1 mm	N1 mm	Y1 mm	Weight (steel) g/1 piece	Triple-Lok® Steel	Triple-Lok® Stainless Steel	Triple-Lok® Brass	PN (bar)
mm	in.												
6	1/4	1/8-27	7/16-20	4	8	27	17	14	45	4 MTX-S	4 MTX-SS	4 MTX-B	350
6	1/4	1/4-18	7/16-20	4	11	29	22	19	10	4-4-4 MTX-S	4-4-4 MTX-SS	4-4-4 MTX-B	350
10	3/8	1/4-18	9/16-18	8	11	32	22	19	88	6 MTX-S	6 MTX-SS	6 MTX-B	350
12	1/2	3/8-18	3/4-16	10	14	36	26	22	125	8 MTX-S	8 MTX-SS	8 MTX-B	310
14, 15, 16	5/8	1/2-14	7/8-14	12	18	42	32	27	210	10 MTX-S	10 MTX-SS	10 MTX-B	210
18, 20	3/4	3/4-14	1 1/16-12	16	23	48	35	33	280	12 MTX-S	12 MTX-SS	12 MTX-B	210
22	7/8	3/4-14	1 3/16-12	18	23	47	36	33	446	14 MTX-S			210
25	1	1-11 1/2	1 5/16-12	21	29	55	41	41	620	16 MTX-S	16 MTX-SS		125
28, 30, 32	1 1/4	1 1/4-11 1/2	1 5/8-12	27	37	59	43	48	805	20 MTX-S	20 MTX-SS		100

Order codes shown are part of our current manufacturing programme. Imperial and metric parts may vary in hexagon dimensions.

$$\frac{\text{PN (bar)}}{10} = \text{PN (MPa)}$$

Pressure ratings – PN shown, apply to Steel and Stainless Steel versions of the product. For Brass parts reduce pressures by 35%

G6X Swivel connector

Triple-Lok® 37° Flare female swivel end / Female NPTF* thread (SAE J476)

*Stainless Steel = NPT to prevent galling

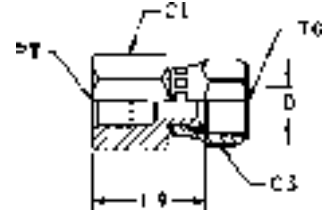

Tube O.D. mm	Tube O.D. in.	Thread NPT/NPTF PT	Thread UN/UNF-2B T6	C1 mm	C3 mm	D mm	L9 mm	Weight (steel) g/1 piece	Triple-Lok® Steel	Triple-Lok® Stainless Steel	PN (bar)
6	1/4	1/8-27	7/16-20	14	14	5	23	29	4 G6X-S	4 G6X-SS	420
6	1/4	1/4-18	7/16-20	19	14	5	27	33	4-4 G6X-S	4-4 G6X-SS	420
10	3/8	1/4-18	9/16-18	19	17	8	27	38	6 G6X-S	6 G6X-SS	350
10	3/8	3/8-18	9/16-18	22	17	7	30	45	6-6 G6X-S	6-6 G6X-SS	350
12	1/2	3/8-18	3/4-16	22	22	10	31	47	8 G6X-S	8 G6X-SS	350
12	1/2	1/2-14	3/4-16	29	22	10	38	99	8-8 G6X-S	8-8 G6X-SS	350
14, 15, 16	5/8	1/2-14	7/8-14	29	25	12	37	99	10 G6X-S	10 G6X-SS	350
18, 20	3/4	3/4-14	1 1/16-12	35	32	16	38	147	12 G6X-S	12 G6X-SS	280
25	1	1-11 1/2	1 5/16-12	41	38	21	47	248	16 G6X-S	16 G6X-SS	210
28, 30, 32	1 1/4	1 1/4-11 1/2	1 5/8-12	50	50	28	55	370	20 G6X-S	20 G6X-SS	170
35, 38	1 1/2	1 1/2-12 1/2	1 7/8-12	60	58	34	57	510	24 G6X-S	24 G6X-SS	140

Order codes shown are part of our current manufacturing programme.
Imperial and metric parts may vary in hexagon dimensions.

$$\frac{\text{PN (bar)}}{10} = \text{PN (MPa)}$$

Pressure ratings – PN shown, apply to Steel and Stainless Steel versions of the product.

K

G4MXMO Pressure gauge connector

Triple-Lok® 37° Flare end / Female BSPP gauge thread (ISO 1179-1)

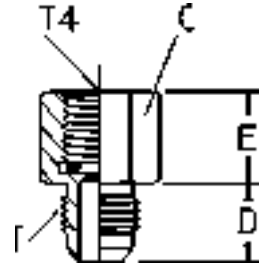

Tube O.D.		Thread BSPP T4	Thread UN/UNF-2A T	D mm	E mm	C mm	Weight (steel) g/1 piece	Triple-Lok® Steel	Triple-Lok® Stainless Steel	PN (bar)
mm	in.									
6	1/4	1/4-19	7/16-20	14	17	17	86	4-4G4MXSMO	4-4G4MXSSMO	350
6	1/4	1/2-14	7/16-20	14	27	27	246	4-8G4MXSMO	4-8G4MXSSMO	315
8	5/16	1/4-19	1/2-20	14	14	17	49	5-4G4MXSMO	5-4G4MXSSMO	350
8	5/16	1/2-14	1/2-20	14	27	27	246	5-8G4MXSMO	5-8G4MXSSMO	315
10	3/8	1/4-19	9/16-18	14	14	17	49	6G4MXSMO	6G4MXSSMO	350
10	3/8	1/2-14	9/16-18	14	21	27	239	6-8G4MXSMO	6-8G4MXSSMO	315
12	1/2	1/4-19	3/4-16	17	14	19	74	8-4G4MXSMO	8-4G4MXSSMO	400
12	1/2	1/2-14	3/4-16	17	21	27	263	8-8G4MXSMO	8-8G4MXSSMO	315

Triple-Lok® is delivered with NBR elastomeric seals as standard. For more details on other seal materials see page K93
 Order codes shown are part of our current manufacturing programme.
 Imperial and metric parts may vary in hexagon dimensions.

$$\frac{\text{PN (bar)}}{10} = \text{PN (MPa)}$$

Pressure ratings – PN shown, apply to Steel and Stainless Steel versions of the product.

TT4MX Test point connection

Triple-Lok® 37° Flare female end / Female BSPP thread (ISO 1179-1)

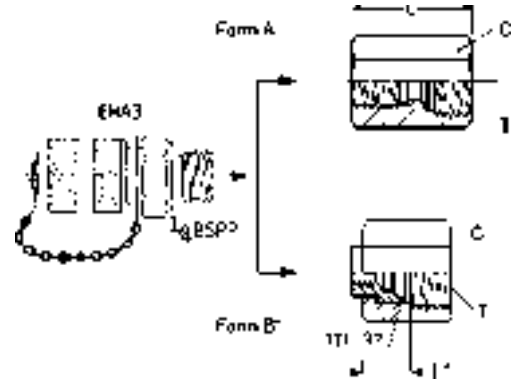

* Form B has to be assembled with a nut BMTX / BTX (not delivered).

Tube O.D. T		Thread BSPP	Thread UN/UNF-2B T	Form	L mm	L1 mm	C mm	Weight (steel) g/1 piece	Triple-Lok® Steel	Triple-Lok® Stainless Steel	PN (bar)
mm	in.										
6	1/4	1/4-19	7/16-20	A	29	-	19	42	4TT4MXS	4TT4MXSS	400
8	5/16	1/4-19	1/2-20	A	29	-	19	46	5TT4MXS	5TT4MXSS	400
10	3/8	1/4-19	9/16-18	A	29	-	19	43	6TT4MXS	6TT4MXSS	400
12	1/2	1/4-19	3/4-16	A	32	-	22	62	8TT4MXS	8TT4MXSS	400
14, 15, 16	5/8	1/4-19	7/8-14	A	32	-	27	102	10TT4MXS	10TT4MXSS	350
18, 20	3/4	1/4-19	1 1/16-12	B	-	13	32	42	12TT4XS	12TT4MXSS	350
25	1	1/4-19	1 5/16-12	B	-	13	41	56	16TT4XS	16TT4MXSS	280
28, 30, 32	1 1/4	1/4-19	1 5/8-12	B	-	15	50	98	20TT4XS	20TT4MXSS	280
35, 38	1 1/2	1/4-19	1 7/8-12	B	-	18	60	185	24TT4XS	24TT4MXSS	210

Order codes shown are part of our current manufacturing programme. Imperial and metric parts may vary in hexagon dimensions.

$$\frac{\text{PN (bar)}}{10} = \text{PN (MPa)}$$

Pressure ratings – PN shown, apply to Steel and Stainless Steel versions of the product.



TTP4MX Test point connection

Triple-Lok® 37° Flare female end / EMA3 test point

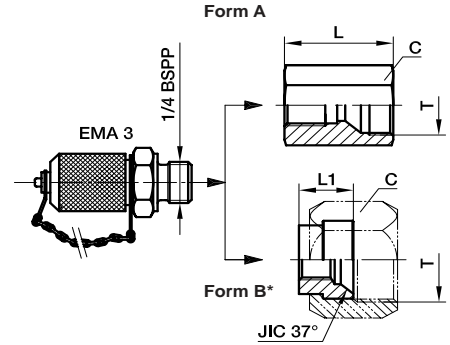

* Form B versions delivered complete with BMTXS nut.

Tube O.D. T		Thread BSPP	Thread UN/UNF-2B T	Form	L mm	L1 mm	C mm	Weight (steel) g/1 piece	Triple-Lok® Steel	PN (bar)
mm	in.									
6	1/4	1/4-19	7/16-20	A	29	–	19	132	4TTP4MXS	400
8	5/16	1/4-19	1/2-20	A	29	–	19	136	5TTP4MXS	400
10	3/8	1/4-19	9/16-18	A	29	–	19	133	6TTP4MXS	400
12	1/2	1/4-19	3/4-16	A	32	–	22	152	8TTP4MXS	400
14, 15, 16	5/8	1/4-19	7/8-14	A	32	–	27	192	10TTP4MXS	350
18, 20	3/4	1/4-19	1 1/16-12	B	–	13	32	132	12TTP4XS	350
25	1	1/4-19	1 5/16-12	B	–	13	41	146	16TTP4XS	280
28, 30, 32	1 1/4	1/4-19	1 5/8-12	B	–	15	50	188	20TTP4XS	280
35, 38	1 1/2	1/4-19	1 7/8-12	B	–	18	60	275	24TTP4XS	210

Order codes shown are part of our current manufacturing programme. Imperial and metric parts may vary in hexagon dimensions.

$$\frac{\text{PN (bar)}}{10} = \text{PN (MPa)}$$

R6O4MX Test point connector

Male / Female swivel Triple-Lok® 37° flare end / Female BSPP thread (ISO 1179-1)

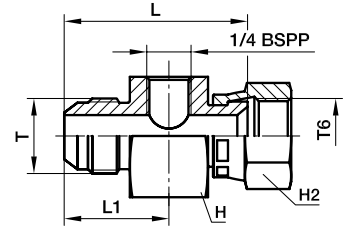

Tube O.D. T		Thread UN/UNF-2A T	Thread UN/UNF-2B T6	L mm	L1 mm	H mm	H2 mm	Weight (steel) g/1 piece	Triple-Lok® Steel	PN (bar)
mm	in.									
6	1/4	7/16-20	7/16-20	45	26	36	16	180	4-4R6O4MXS	500
8	5/16	1/2-20	1/2-20	46	26	36	17	200	5-4R6O4MXS	420
10	3/8	9/16-18	9/16-18	47	26	36	19	210	6-4R6O4MXS	350
12	1/2	3/4-16	3/4-16	50	28	36	22	218	8-4R6O4MXS	350
14, 15, 16	5/8	7/8-14	7/8-14	54	31	36	27	247	10-4R6O4MXS	350
18, 20	3/4	1 1/16-12	1 1/16-12	56	34	41	32	326	12-4R6O4MXS	350
25	1	1 5/16-12	1 5/16-12	60	35	46	38	416	16-4R6O4MXS	250
28, 30, 32	1 1/4	1 5/8-12	1 5/8-12	64	36	50	50	601	20-4R6O4MXS	250
35, 38	1 1/2	1 7/8-12	1 7/8-12	69	39	60	60	905	24-4R6O4MXS	170

Order codes shown are part of our current manufacturing programme.
Imperial and metric parts may vary in hexagon dimensions.

$$\frac{\text{PN (bar)}}{10} = \text{PN (MPa)}$$



R6P4MX Test point connector

Male / Female swivel Triple-Lok® 37° flare end / EMA3 test point

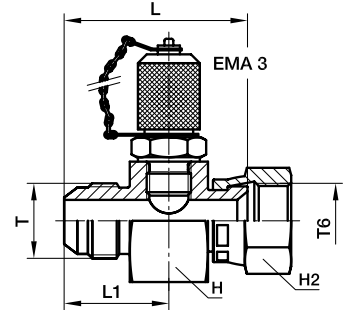

Tube O.D. T		Thread UN/UNF-2A T	Thread UN/UNF-2B T6	L	L1	H	H2	Weight (steel) g/1 piece	Triple-Lok® Steel	PN (bar)
mm	in.			mm	mm	mm	mm			
6	1/4	7/16-20	7/16-20	45	26	36	16	270	4-4R6P4MXS	500
8	5/16	1/2-20	1/2-20	46	26	36	17	290	5-4R6P4MXS	420
10	3/8	9/16-18	9/16-18	47	26	36	19	300	6-4R6P4MXS	350
12	1/2	3/4-16	3/4-16	50	28	36	22	308	8-4R6P4MXS	350
14, 15, 16	5/8	7/8-14	7/8-14	54	31	36	27	337	10-4R6P4MXS	350
18, 20	3/4	1 1/16-12	1 1/16-12	56	34	41	32	416	12-4R6P4MXS	350
25	1	1 5/16-12	1 5/16-12	60	35	46	38	506	16-4R6P4MXS	250
28, 30, 32	1 1/4	1 5/8-12	1 5/8-12	64	36	50	50	691	20-4R6P4MXS	250
35, 38	1 1/2	1 7/8-12	1 7/8-12	69	39	60	60	995	24-4R6P4MXS	170

Order codes shown are part of our current manufacturing programme.
Imperial and metric parts may vary in hexagon dimensions.

$$\frac{\text{PN (bar)}}{10} = \text{PN (MPa)}$$

K6004MX Test point connector

Male / Female swivel Triple-Lok® 37° flare end / 2 BSPP female threads

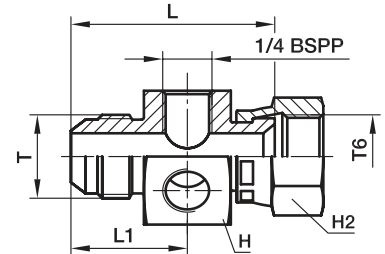

Tube O.D. T		Thread UN/UNF-2A T	Thread UN/UNF-2B T6	L mm	L1 mm	H mm	H2 mm	Weight (steel) g/1 piece	Triple-Lok® Steel	PN (bar)
mm	in.									
6	1/4	7/16-20	7/16-20	45	26	36	16	170	4-4K6004MXS	500
8	5/16	1/2-20	1/2-20	46	26	36	17	190	5-4K6004MXS	420
10	3/8	9/16-18	9/16-18	47	26	36	19	200	6-4K6004MXS	350
12	1/2	3/4-16	3/4-16	50	28	36	22	208	8-4K6004MXS	350
14, 15, 16	5/8	7/8-14	7/8-14	54	31	36	27	237	10-4K6004MXS	350
18, 20	3/4	1 1/16-12	1 1/16-12	56	34	41	32	316	12-4K6004MXS	350
25	1	1 5/16-12	1 5/16-12	60	35	46	38	406	16-4K6004MXS	250

Order codes shown are part of our current manufacturing programme.
Imperial and metric parts may vary in hexagon dimensions.

$$\frac{\text{PN (bar)}}{10} = \text{PN (MPa)}$$

K

K6PP4MX Test point connector

Male / female swivel Triple-Lok® 37° flare end / EMA3 test point & blanking plug

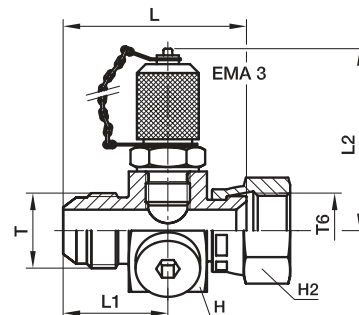

Tube O.D. T		Thread UN/UNF-2A T	Thread UN/UNF-2B T6	L mm	L1 mm	L2 mm	H mm	H2 mm	Weight (steel) g/1 piece	Triple-Lok® Steel	PN (bar)
mm	in.										
6	1/4	7/16-20	7/16-20	45	26	54	36	16	270	4-4K6PP4MXS	500
8	5/16	1/2-20	1/2-20	46	26	54	36	17	290	5-4K6PP4MXS	420
10	3/8	9/16-18	9/16-18	47	26	54	36	19	300	6-4K6PP4MXS	350
12	1/2	3/4-16	3/4-16	50	28	54	36	22	308	8-4K6PP4MXS	350
14, 15, 16	5/8	7/8-14	7/8-14	54	31	54	36	27	337	10-4K6PP4MXS	350
18, 20	3/4	1 1/16-12	1 1/16-12	56	34	54	41	32	416	12-4K6PP4MXS	350
25	1	1 5/16-12	1 5/16-12	60	35	54	46	38	506	16-4K6PP4MXS	250

Order codes shown are part of our current manufacturing programme. Imperial and metric parts may vary in hexagon dimensions.

$$\frac{\text{PN (bar)}}{10} = \text{PN (MPa)}$$

FNMTX Cap

Triple-Lok® 37° Flare female swivel cap end
SAE 070112 MS51532

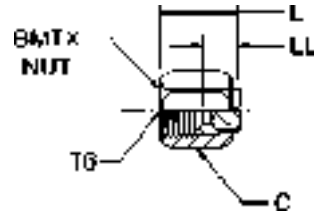

Tube O.D.		Thread UN/UNF-2B T6	C mm	LL mm	L mm	Weight (steel) g/1 piece	Triple-Lok® Steel	Triple-Lok® Stainless Steel	Triple-Lok® Brass	PN (bar)
mm	in.									
6	1/8	5/16-24	10	10	15	10	2 FNTX-S			500
	3/16	3/8-24	11	10	17	11	3 FNTX-S			500
	1/4	7/16-20	14	9	17	14	4FNMTXS	4FNMTXSS	4 FNTX-B	500
	5/16	1/2-20	17	10	20	19	5FNMTXS	5FNMTXSS	5 FNTX-B	420
8	3/8	9/16-18	19	12	21	31	6FNMTXS	6FNMTXSS	6 FNTX-B	420
10	1/2	3/4-16	22	14	24	45	8FNMTXS	8FNMTXSS	8 FNTX-B	420
14, 15, 16	5/8	7/8-14	27	14	27	75	10FNMTXS	10FNMTXSS	10 FNTX-B	350
18, 20	3/4	1 1/16-12	32	17	32	114	12FNMTXS	12FNMTXSS	12 FNTX-B	350
22	7/8	1 3/16-12	35	16	32	133	14 FNTX-S	14FNMTXSS	14 FNTX-B	310
25	1	1 5/16-12	41	16	33	200	16FNMTXS	16FNMTXSS	16 FNTX-B	310
28, 30, 32	1 1/4	1 5/8-12	50	19	35	272	20FNMTXS	20FNMTXSS	20 FNTX-B	280
35, 38	1 1/2	1 7/8-12	60	24	43	553	24FNMTXS	24FNMTXSS	24 FNTX-B	210
	2	2 1/2-12	73	28	51	930	32 FNTX-S			140

Order codes shown are part of our current manufacturing programme.
Imperial and metric parts may vary in hexagon dimensions.

$$\frac{\text{PN (bar)}}{10} = \text{PN (MPa)}$$

Pressure ratings – PN shown, apply to Steel and Stainless Steel versions of the product.
For Brass parts reduce pressures by 35%

PNMTX Plug

Triple-Lok® 37° Flare end plug
SAE 070109 MS51518

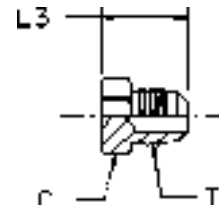

Tube O.D.		Thread UN/UNF-2A T	C mm	L3 mm	Weight (steel) g/1 piece	Triple-Lok® Steel	Triple-Lok® Stainless Steel	PN (bar)
mm	in.							
6	1/8	5/16-24	11	18	9	2 PNTX-S		500
	3/16	3/8-24	11	19	10	3 PNTX-S		500
	1/4	7/16-20	13	20	10	4PNMTXS	4PNMTXSS	500
	5/16	1/2-20	14	20	14	5PNMTXS	5PNMTXSS	420
	3/8	9/16-18	17	21	19	6PNMTXS	6PNMTXSS	420
12, 15, 16	1/2	3/4-16	19	24	39	8PNMTXS	8PNMTXSS	420
	5/8	7/8-14	24	28	60	10PNMTXS	10PNMTXSS	350
	3/4	1 1/16-12	27	33	93	12PNMTXS	12PNMTXSS	350
	7/8	1 3/16-12	32	33	95	14 PNTX-S	14PNMTXSS	280
	1	1 5/16-12	36	34	98	16PNMTXS	16PNMTXSS	280
28, 30, 32	1 1/4	1 5/8-12	46	37	269	20PNMTXS	20PNMTXSS	280
	1 1/2	1 7/8-12	51	42	360	24 PNTX-S	24PNMTXSS	210
		2	2 1/2-12	67	52	470	32 PNTX-S	

Order codes shown are part of our current manufacturing programme.
Imperial and metric parts may vary in hexagon dimensions.

$$\frac{\text{PN (bar)}}{10} = \text{PN (MPa)}$$

Pressure ratings – PN shown, apply to Steel and Stainless Steel versions of the product.

XHMLO Conversion union

Triple-Lok® 37° Flare End / O-Lok ORFS end

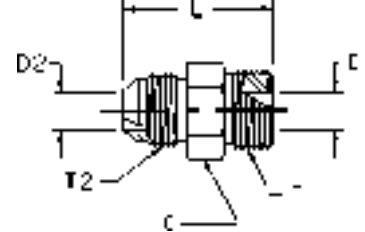

Tube O.D. T2/T		Thread UN/UNF-2A T2	Thread UN/UNF-2A T	D mm	D2 mm	L mm	C mm	Weight (steel) g/1 piece	Triple-Lok® Steel	Triple-Lok® Stainless Steel	PN (bar)
mm	in.										
6	1/4	7/16-20	9/16-18	5	5	32	16	29	4 XHLO-S	4XHMLOSS	500
8, 10	5/16, 3/8	9/16-18	11/16-16	7	7	34	19	45	6 XHLO-S	6XHMLOSS	420
12	1/2	3/4-16	13/16-16	10	10	39	22	70	8 XHLO-S	8XHMLOSS	420
14, 15, 16	5/8	7/8-14	1-14	13	13	47	27	119	10 XHLO-S	10XHMLOSS	350
18, 20	3/4	1 1/16-12	1 3/16-12	16	16	52	32	181	12 XHLO-S	12XHMLOSS	350
22, 25	1	1 5/16-12	1 7/16-12	21	21	55	38	265	16 XHLO-S	16XHMLOSS	280
28, 30, 32	1 1/4	1 5/8-12	1 11/16-12	26	26	58	45	383	20 XHLO-S	20XHMLOSS	280
35, 38	1 1/2	1 7/8-12	2-12	32	32	63	54	562	24 XHLO-S	24XHMLOSS	210

Triple-Lok® is delivered with NBR elastomeric seals as standard. For more details on other seal materials see page K93
 Order codes shown are part of our current manufacturing programme.
 Imperial and metric parts may vary in hexagon dimensions.

$$\frac{\text{PN (bar)}}{10} = \text{PN (MPa)}$$

Pressure ratings – PN shown, apply to Steel and Stainless Steel versions of the product.

K

XHML6 Conversion swivel nut connector

Triple-Lok® 37° Flare end / O-Lok ORFS female swivel end

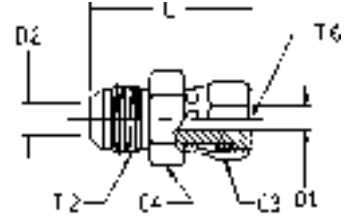

Tube O.D. T2/T6		Thread UN/UNF-2A T2	Thread UN/UNF-2B T6	C3 mm	D1 mm	D2 mm	L mm	C4 mm	Weight (steel) g/1 piece	Triple-Lok® Steel	Triple-Lok® Stainless Steel	PN (bar)
6	1/4	7/16-20	9/16-18	17	4	4	38	16	29	4 XHL6-S	4XHML6SS	500
8, 10	5/16, 3/8	9/16-18	11/16-16	21	7	7	41	19	46	6 XHL6-S	6XHML6SS	420
12	1/2	3/4-16	13/16-16	24	9	9	48	22	73	8 XHL6-S	8XHML6SS	420
14, 15, 16	5/8	7/8-14	1-14	29	12	12	56	27	126	10 XHL6-S	10XHML6SS	350
18, 20	3/4	1 1/16-12	1 3/16-12	35	14	14	64	32	205	12 XHL6-S	12XHML6SS	350
22, 25	1	1 5/16-12	1 7/16-12	41	20	20	68	38	285	16 XHL6-S	16XHML6SS	280
28, 30, 32	1 1/4	1 5/8-12	1 11/16-12	48	26	26	71	43	360	20 XHL6-S	20XHML6SS	280

Order codes shown are part of our current manufacturing programme.
Imperial and metric parts may vary in hexagon dimensions.

$$\frac{\text{PN (bar)}}{10} = \text{PN (MPa)}$$

Pressure ratings – PN shown, apply to Steel and Stainless Steel versions of the product.

LOHMX6 Conversion swivel nut connector

Triple-Lok® 37° Flare female swivel end / O-Lok ORFS end

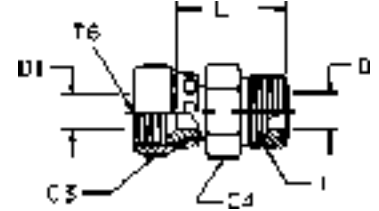

Tube O.D. T6/T		Thread UN/UNF-2B T6	Thread UN/UNF-2A T	C3	D	D1	C4	L	Weight (steel) g/1 piece	Triple-Lok® Steel	Triple-Lok® Stainless Steel	PN (bar)
mm	in.			mm	mm	mm	mm	mm				
6	1/4	7/16-20	9/16-18	14	5	5	16	26	26	4 LOHX6-S	4LOHMX6SS	500
8, 10	5/16, 3/8	9/16-18	11/16-16	18	7	7	19	29	40	6 LOHX6-S	6LOHMX6SS	350
12	1/2	3/4-16	13/16-16	22	10	10	22	34	63	8 LOHX6-S	8LOHMX6SS	350
14, 15, 16	5/8	7/8-14	1-14	25	13	13	27	39	103	10 LOHX6-S	10LOHMX6SS	350
18, 20	3/4	1 1/16-12	1 3/16-12	32	16	16	32	41	162	12 LOHX6-S	12LOHMX6SS	350
22, 25	1	1 5/16-12	1 7/16-12	38	21	21	38	46	229	16 LOHX6-S	16LOHMX6SS	250

Triple-Lok® is delivered with NBR elastomeric seals as standard. For more details on other seal materials see page K93

Order codes shown are part of our current manufacturing programme.

Imperial and metric parts may vary in hexagon dimensions.

$$\frac{\text{PN (bar)}}{10} = \text{PN (MPa)}$$

Pressure ratings – PN shown, apply to Steel and Stainless Steel versions of the product.

K

WLNM Bulkhead locknut

Bulkhead fitting locknut
SAE 080118 MS51860

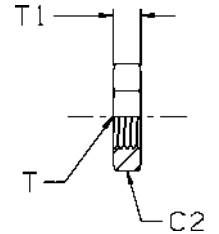

Thread UN/UNF-2B T	C2 mm	T1 mm	Weight (steel) g/1 piece	Triple-Lok® Steel	Triple-Lok® Stainless Steel	Triple-Lok® Brass
3/8-24	17	6	9	3 WLN-S		
7/16-20	17	7	9	4WLNMS	4WLNMS	4WLNMB
1/2-20	19	7	9	5WLNMS	5WLNMS	5WLNMB
9/16-18	22	7	11	6WLNMS	6WLNMS	6WLNMB
3/4-16	24	8	18	8WLNMS	8WLNMS	8WLNMB
7/8-14	30	9	24	10WLNMS	10WLNMS	10WLNMB
1 1/16-12	36	10	42	12WLNMS	12WLNMS	12WLNMB
1 3/16-12	38	10	45	14 WLN-S	14WLNMS	14WLNMB
1 5/16-12	41	10	49	16WLNMS	16WLNMS	16WLNMB
1 5/8-12	50	10	50	20WLNMS	20WLNMS	20WLNMB
1 7/8-12	55	10	68	24WLNMS	24WLNMS	24WLNMB
2 1/2-12	70	10	80	32 WLN-S		

Order codes shown are part of our current manufacturing programme.
Imperial and metric parts may vary in hexagon dimensions.

Spare parts guide – Triple-Lok® retaining rings and seals

BSP Male threads – ISO 1179

BSP Thread	ED Seal Order code		O-ring Order code*		O-Ring ID section (mm)	Retainer ring Order code Steel	Retainer ring Order code Stainless Steel
	NBR	FKM	NBR	FKM			
1/8	ED10X1X	ED10X1VITX	6-002-N552-9	6-002-V894-9	8.00 2.00	8207-1/8	8207SS1/8
1/4	ED14X1.5X	ED14X1.5VITX	2-111-N552-9	2-111-V894-9	10.77 2.62	8207-1/4	8207SS1/4A
3/8	ED3/8X	ED3/8VITX	2-113-N552-9	2-113-V894-9	13.94 2.62	8207-3/8	8207SS3/8A
1/2	ED1/2X	ED1/2VITX	5-256-N552-9	5-256-V894-9	17.96 2.62	8207-1/2	8207SS1/2
3/4	ED26X1.5X	ED26X1.5VITX	2-119-N552-9	2-119-V894-9	23.47 2.62	8207-3/4	8207SS3/4
1	ED33X2X	ED33X2VITX	2-217-N552-9	2-217-V894-9	29.74 3.53	8207-1	8207SS1A
1 1/4	ED42X2X	ED42X2VITX	2-222-N552-9	2-222-V894-9	37.69 3.53	8207-1-1/4	8207SS1 1/4
1 1/2	ED48X2X	ED48X2VITX	2-224-N552-9	2-224-V894-9	44.04 3.53	8207-1-1/2	8207SS1 1/2

Typical fittings using these parts: F42EDMX / F4OMX / C4OMX / V4OMX etc.

* Must be used with correct retainer ring

Metric male threads – ISO 9974

Metric Thread	ED Seal Order code		O-ring Order code*		O-Ring ID section (mm)	Retainer ring Order code Steel	Retainer ring Order code Stainless Steel
	NBR	FKM	NBR	FKM			
M10x1	ED10X1X	ED10X1VITX	6-074-N552-9	6-074-V894-9	8.00 1.50	M10RR	RRM10X1SS
M12x1.5	ED12X1.5X	ED12X1.5VITX	2-012-N552-9	2-012-V894-9	9.25 1.78	M12RR	RRM12X1.5SS
M14x1.5	ED14X1.5X	ED14X1.5VITX	2-013-N552-9	2-013-V894-9	10.82 1.78	M14RR	RRM14X1.5SS
M16x1.5	ED16X1.5X	ED16X1.5VITX	3-907-N552-9	3-907-V894-9	13.46 2.08	M16RR	RRM16X1.5SS
M18x1.5	ED18X1.5X	ED18X1.5VITX	2-114-N552-9	2-114-V894-9	15.54 2.62	M18RR	RRM18X1.5SS
M22x2	ED22X1.5X	ED22X1.5VITX	2-018-N552-9	2-018-V894-9	18.77 1.78	M22RR	RRM22X1.5SS
M27x2	ED26X1.5X**	ED26X1.5VITX	2-119-N552-9	2-119-V894-9	23.47 2.62	M27RR	RRM27X2SS
M33x2	ED33X2X	ED33X2VITX	2-122-N552-9	2-122-V894-9	28.24 2.62	M33RR	RRM33X2SS
M42x2	ED42X2X	ED42X2VITX	2-128-N552-9	2-128-V894-9	37.77 2.62	M42RR	RRM42X2SS
M48x2	ED48X2X	ED48X2VITX	2-132-N552-9	2-132-V894-9	44.12 2.62	M48RR	RRM48X2SS

Typical fittings using these parts: F82EDMX / F8OMX / C8OMX / V8OMX etc.

* Must be used with correct retainer ring

** Same seal used for M26X1.5 and M27X2 Threads

UN / UNF male threads – ISO 11926

UN / UNF Thread	Dash size	O-ring Order code*		O-Ring ID x section (mm)	
		NBR	FKM		
5/16-24	2	3-902-N552-9	3-902-V894-9	6.07	1.63
3/8-24	3	3-903-N552-9	3-903-V894-9	7.65	1.63
7/16-20	4	3-904-N552-9	3-904-V894-9	8.92	1.83
1/2-20	5	3-905-N552-9	3-905-V894-9	10.52	1.83
9/16-18	6	3-906-N552-9	3-906-V894-9	11.89	1.98
3/4-16	8	3-908-N552-9	3-908-V894-9	16.36	2.21
7/8-14	10	3-910-N552-9	3-910-V894-9	19.18	2.46
1 1/16-12	12	3-912-N552-9	3-912-V894-9	23.47	2.95
1 3/16-12	14	3-914-N552-9	3-914-V894-9	26.59	2.95
1 5/16-12	16	3-916-N552-9	3-916-V894-9	29.74	2.95
1 5/8-12	20	3-920-N552-9	3-920-V894-9	37.47	3.00
1 7/8-12	24	3-924-N552-9	3-924-V894-9	43.69	3.00
2 1/2-12	32	3-932-N552-9	3-932-V894-9	59.36	3.00

Typical fittings using these parts: F5OMX / C5OMX / R5OMX etc.

Other seal compounds available on request for alternative applications

Metric male threads – ISO 6149

Metric Thread		O-ring Order code*		O-Ring ID section (mm)	
		NBR	FKM		
M10	1	6-345-N552-9	6-345-V894-9	8.20	1.50
M12	1.5	6-346-N552-9	6-346-V894-9	9.40	2.10
M14	1.5	6-347-N552-9	6-347-V894-9	11.40	2.10
M16	1.5	6-348-N552-9	6-348-V894-9	13.40	2.10
M18	1.5	6-349-N552-9	6-349-V894-9	15.40	2.10
M22	1.5	6-350-N552-9	6-350-V894-9	19.40	2.10
M27	2	6-351-N552-9	6-351-V894-9	23.70	2.80
M33	2	6-352-N552-9	6-352-V894-9	29.70	2.80
M42	2	6-353-N552-9	6-353-V894-9	38.70	2.80
M48	2	6-354-N552-9	6-354-V894-9	46.70	2.80

Typical fittings using these parts: F87OMX / S87OMX etc.



EO[®] Ermeto Original
Weld fittings

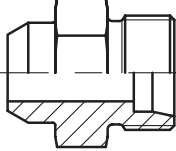
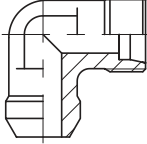
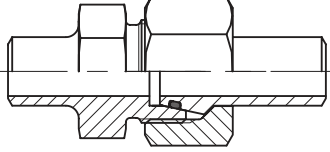
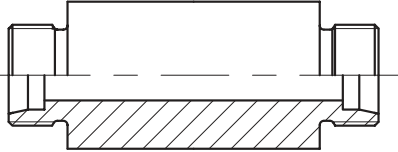
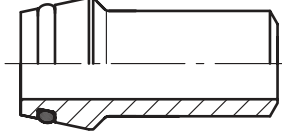
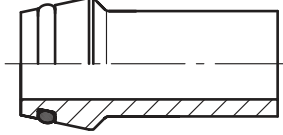
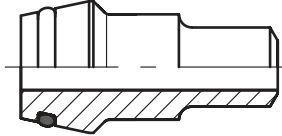
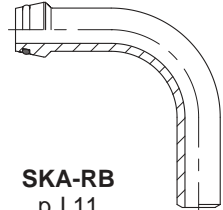
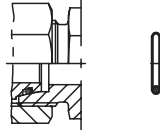

Visual index

<p>Tube to weld</p>	 <p>AS p. L3</p>	 <p>WAS p. L4</p>
<p>Weld fitting</p>	 <p>ASK p. L5</p>	
<p>Weld bulkhead</p>	 <p>ESV p. L6</p>	
<p>Weld nipple</p>	 <p>SKA p. L7</p>	 <p>SKA-ORB p. L10</p>
<p>Reducing weld nipple</p>	 <p>SKAR p. L8/9</p>	
<p>Tube bend weld nipple</p>	 <p>SKA-RB p. L11</p>	
<p>O-ring</p>	 <p>O-ring p. L12</p>	

AS weld connector

Butt weld / EO 24° cone end

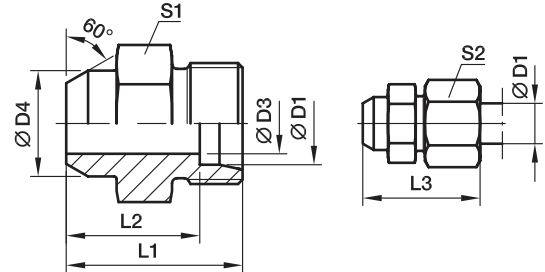

Series	D1 	D3	D4	L1	L2	L3	S1	S2	Weight g/1 piece	Order code	PN (bar) ¹⁾	
											Steel	Stainless Steel
L ³⁾	06	4	10	21	14.0	29	12	14	11	AS06L	315	315
	08	6	12	23	16.0	31	14	17	15	AS08L	315	315
	10	8	14	25	18.0	33	17	19	22	AS10L	315	315
	12	10	16	25	18.0	33	19	22	25	AS12L	315	315
	15	12	19	29	22.0	37	22	27	44	AS15L	315	315
	18	15	22	31	23.5	40	27	32	67	AS18L	315	315
	22	19	27	36	28.5	45	32	36	98	AS22L	160	160
	28	24	32	38	30.5	47	41	41	165	AS28L	160	160
	35	30	40	43	32.5	54	46	50	232	AS35L	160	160
	42	36	46	46	35.0	58	55	60	342	AS42L	160	160
S ⁴⁾	06	4	11	26	19.0	34	14	17	21	AS06S	630	630
	08	5	13	28	21.0	36	17	19	31	AS08S	630	630
	10	7	15	30	22.5	39	19	22	41	AS10S	630	630
	12	8	17	32	24.5	41	22	24	93	AS12S	630	630
	14	10	19	35	27.0	45	24	27	55	AS14S	630	630
	16	12	21	35	26.5	45	27	30	82	AS16S	400	400
	20	16	26	40	29.5	51	32	36	131	AS20S	400	400
	25	20	31	44	32.0	56	41	46	219	AS25S	400	400
	30	25	36	49	35.5	62	46	50	297	AS30S	400	400
	38	32	44	54	38.0	69	55	60	448	AS38S	315	315

¹⁾ Pressure shown = item deliverable

³⁾ L = light series; ⁴⁾ S = heavy series

$$\frac{\text{PN (bar)}}{10} = \text{PN (MPa)}$$

Delivery without nut and ring. Information on ordering complete fittings or alternative sealing materials see page 17.

*Please add the **suffixes** below according to the material/surface required.

Order code suffixes		
Material	Suffix surface and material	Example
Steel		AS16SX
Stainless Steel	71X	AS16S71X

WAS Weld elbow

Butt weld / EO 24° cone end

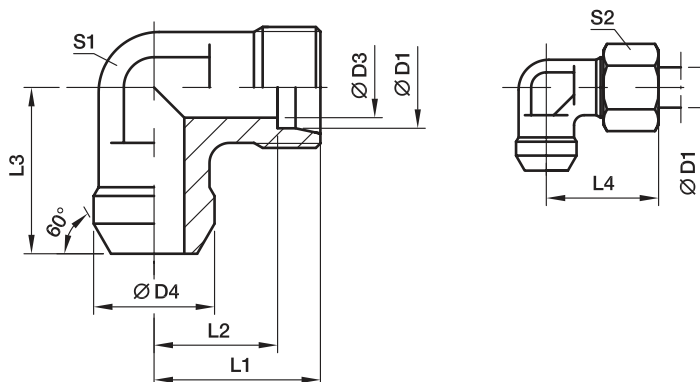

Series	D1	D3	D4	L1	L2	L3	L4	S1	S2	Weight g/1 piece	Order code	PN (bar) ¹⁾	
												Steel	Stainless Steel
L ³⁾	06	4	10	19	12.0	19	27	12	14	20	WAS06L	315	315
	08	6	12	21	14.0	23	29	12	17	25	WAS08L	315	315
	10	8	14	22	15.0	24	30	14	19	34	WAS10L	315	315
	12	10	16	24	17.0	25	32	17	22	45	WAS12L	315	315
	15	12	19	28	21.0	30	36	19	27	81	WAS15L	315	315
	18	15	22	31	23.5	33	40	24	32	113	WAS18L	315	315
	22	19	27	35	27.5	37	44	27	36	151	WAS22L	160	160
	28	24	32	38	30.5	42	47	36	41	271	WAS28L	160	160
	35	30	40	45	34.5	49	56	41	50	113	WAS35L	160	160
	42	36	46	51	40.0	57	63	50	60	420	WAS42L	160	160
S ⁴⁾	06	4	11	23	16.0	23	31	12	17	31	WAS06S	630	630
	08	5	13	24	17.0	24	32	14	19	44	WAS08S	630	630
	10	7	15	25	17.5	25	34	17	22	59	WAS10S	630	630
	12	8	17	29	21.5	29	38	17	24	78	WAS12S	630	630
	14	10	19	30	22.0	30	40	19	27	98	WAS14S	630	630
	16	12	21	33	24.5	33	43	24	30	133	WAS16S	400	400
	20	16	26	37	26.5	37	48	27	36	192	WAS20S	400	400
	25	20	31	42	30.0	42	54	36	46	351	WAS25S	400	400
	30	25	36	49	35.5	49	62	41	50	525	WAS30S	400	400
	38	32	44	57	41.0	57	72	50	60	785	WAS38S	315	315

¹⁾ Pressure shown = item deliverable

³⁾ L = light series; ⁴⁾ S = heavy series

$$\frac{PN \text{ (bar)}}{10} = PN \text{ (MPa)}$$

Delivery without nut and ring. Information on ordering complete fittings or alternative sealing materials see page 17.

*Please add the **suffixes** below according to the material/surface required.

Order code suffixes		
Material	Suffix surface and material	Example
Steel		WAS16SX
Stainless Steel	71X	WAS16S71X

ASK Weld fitting for tubes

Butt weld / Butt weld

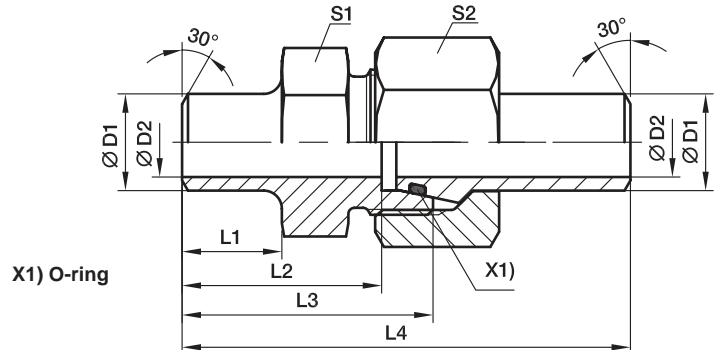

Series	D1 	D2	L1	L2	L3	L4	S1	S2	recommended tube	Weight g/1 piece	Order code	PN (bar) ¹⁾	
												Steel	Stainless Steel
S ⁴⁾	10	8	10.0	24.5	32.0	58.0	19	22	10X1.0	75	ASK610X1S	249	242
	10	7	10.0	24.5	32.0	58.0	19	22	10X1.5	81	ASK610X1.5S	358	349
	10	6	10.0	24.5	32.0	58.0	19	22	10X2.0	86	ASK610X2S	460	447
	12	9	15.0	29.5	37.0	63.0	22	24	12X1.5	106	ASK612X1.5S	305	297
	12	8	15.0	29.5	37.0	63.0	22	24	12X2.0	107	ASK612X2S	393	383
	12	7	15.0	29.5	37.0	63.0	22	24	12X2.5	109	ASK612X2.5S	476	463
	16	13	16.5	33.0	41.5	73.5	27	30	16X1.5	166	ASK616X1.5S	234	228
	16	12	16.5	33.0	41.5	73.5	27	30	16X2.0	175	ASK616X2S	305	297
	16	11	16.5	33.0	41.5	73.5	27	30	16X2.5	184	ASK616X2.5S	372	362
	16	10	16.5	33.0	41.5	73.5	27	30	16X3.0	193	ASK616X3S	400	400
	20	16	19.0	36.5	47.0	83.5	32	36	20X2.0	301	ASK620X2S	249	242
	20	15	19.0	36.5	47.0	83.5	32	36	20X2.5	311	ASK620X2.5S	305	297
	20	14	19.0	36.5	47.0	83.5	32	36	20X3.0	316	ASK620X3S	358	349
	20	12	19.0	36.5	47.0	83.5	32	36	20X4.0	322	ASK620X4S	400	400
	25	19	19.5	39.5	51.5	92.5	41	46	25X3.0	551	ASK625X3S	294	286
	25	17	19.5	39.5	51.5	92.5	41	46	25X4.0	559	ASK625X4S	379	369
25	15	19.5	39.5	51.5	92.5	41	46	25X5.0	589	ASK625X5S	400	400	
30	24	23.0	44.5	58.0	101.5	46	50	30X3.0	671	ASK630X3S	249	242	
30	22	23.0	44.5	58.0	101.5	46	50	30X4.0	679	ASK630X4S	323	314	
30	20	23.0	44.5	58.0	101.5	46	50	30X5.0	726	ASK630X5S	393	383	
30	18	23.0	44.5	58.0	101.5	46	50	30X6.0	791	ASK630X6S	400	400	
38	30	22.0	44.0	60.0	108.0	55	60	38X4.0	988	ASK638X4S	261	254	
38	28	22.0	44.0	60.0	108.0	55	60	38X5.0	1044	ASK638X5S	315	311	
38	26	22.0	44.0	60.0	108.0	55	60	38X6.0	1108	ASK638X6S	315	315	
38	24	22.0	44.0	60.0	108.0	55	60	38X7.0	1205	ASK638X7S	315	315	

¹⁾ Pressure shown = item deliverable

⁴⁾ S = heavy series

$$\frac{\text{PN (bar)}}{10} = \text{PN (MPa)}$$

*Please add the **suffixes** below according to the material/surface required.

Order code suffixes			
Material	Suffix surface and material	Example	Standard sealing material (no additional suffix needed)
Steel		ASK616X2S	NBR
Stainless Steel	71	ASK616X2S71	VIT

ESV Weld bulkhead fitting

EO 24° cone end / EO 24° cone end

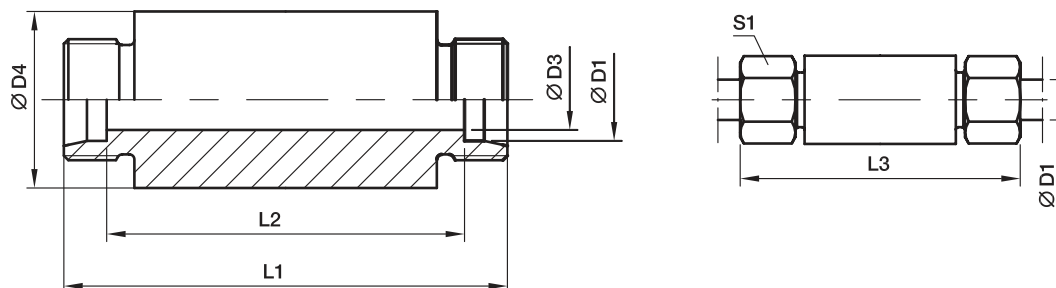

Series	D1	D3	D4	L1	L2	L3	S1	Weight g/1 piece	Order code	PN (bar) ¹⁾	
										Steel	Stainless Steel
L ³⁾	06	4	18	70	56	85	14	103	ESV06L	315	315
	08	6	20	70	56	85	17	121	ESV08L	315	315
	10	8	22	72	58	87	19	142	ESV10L	315	315
	12	10	25	72	58	87	22	176	ESV12L	315	315
	15	12	28	84	70	100	27	262	ESV15L	315	315
	18	15	32	84	69	101	32	333	ESV18L	315	315
	22	19	36	88	73	105	36	394	ESV22L	160	160
	28	24	40	88	73	106	41	448	ESV28L	160	160
	35	30	50	92	71	114	50	713	ESV35L	160	160
	42	36	60	92	70	115	60	997	ESV42L	160	160
S ⁴⁾	06	4	20	74	60	89	17	135	ESV06S	630	630
	08	5	22	74	60	89	19	163	ESV08S	630	630
	10	7	25	74	59	91	22	201	ESV10S	630	630
	12	8	28	74	59	91	24	249	ESV12S	630	630
	14	10	30	88	72	107	27	337	ESV14S	630	630
	16	12	35	88	71	107	30	441	ESV16S	400	400
	20	16	38	92	71	114	36	509	ESV20S	400	400
	25	20	45	96	72	120	46	720	ESV25S	400	400
	30	25	50	100	73	126	50	873	ESV30S	400	400
	38	32	60	104	72	133	60	1248	ESV38S	315	315

¹⁾ Pressure shown = item deliverable

³⁾ L = light series; ⁴⁾ S = heavy series

$$\frac{\text{PN (bar)}}{10} = \text{PN (MPa)}$$

Delivery without nut and ring. Information on ordering complete fittings or alternative sealing materials see page 17.

*Please add the **suffixes** below according to the material/surface required.

Order code suffixes		
Material	Suffix surface and material	Example
Steel		ESV16SX
Stainless Steel	71X	ESV16S71X

SKA Weld nipple

EO 24° O-ring weld nipple / butt weld

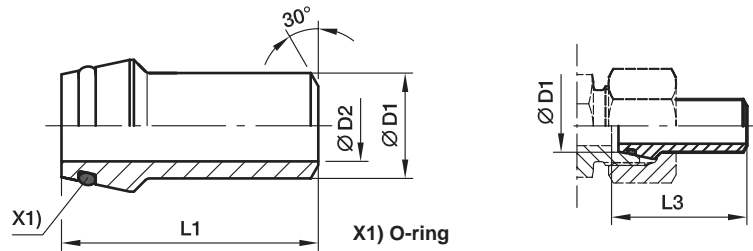

Series	D1	D2	L1	L3	recommended tube	Weight g/1 piece	Order code	PN (bar) ¹⁾	
								Steel	Stainless Steel
L ³⁾ /S ⁴⁾	06	3.0	31.0	31.5	6X1.5	7	SKA06X1.5	528	539
	08	4.5	31.0	31.5	8X1.5	11	SKA08X1.5	414	424
	08	4.0	31.0	31.5	8X2.0	11	SKA08X2	528	539
	10	8.0	32.5	33.5	10X1.0	13	SKA10X1	249	242
	10	7.0	32.5	33.5	10X1.5	13	SKA10X1.5	358	349
	10	6.0	32.5	33.5	10X2.0	16	SKA10X2	460	447
	12	9.0	32.5	33.5	12X1.5	21	SKA12X1.5	305	297
	12	8.0	32.5	33.5	12X2.0	20	SKA12X2	393	383
	12	7.0	32.5	33.5	12X2.5	22	SKA12X2.5	476	463
	L ³⁾	15	11.0	34.0	34.5	15X2.0	29	SKA15X2	315
15		10.0	34.0	34.5	15X2.5	31	SKA15X2.5	315	315
18		13.0	35.5	36.5	18X2.5	40	SKA18X2.5	315	315
22		17.0	38.5	39.5	22X2.5	57	SKA22X2.5	160	160
28		23.0	41.5	42.5	28X2.5	73	SKA28X2.5	160	160
28		22.0	41.5	42.5	28X3.0	89	SKA28X3	160	160
35		28.0	47.5	49.5	35X3.5	140	SKA35X3.5	160	160
35		27.0	47.5	49.5	35X4.0	150	SKA35X4	160	160
42		36.0	47.5	50.0	42X3.0	155	SKA42X3	160	160
42		34.0	47.5	50.0	42X4.0	190	SKA42X4	160	160
S ⁴⁾	14	10.0	38.5	39.5	14X2.0	26	SKA14X2	343	334
	14	8.0	38.5	39.5	14X3.0	33	SKA14X3	487	474
	16	13.0	39.0	40.5	16X1.5	32	SKA16X1.5	234	228
	16	12.0	39.0	40.5	16X2.0	31	SKA16X2	305	297
	16	11.0	39.0	40.5	16X2.5	38	SKA16X2.5	372	362
	16	10.0	39.0	40.5	16X3.0	41	SKA16X3	400	400
	20	16.0	45.0	47.0	20X2.0	57	SKA20X2	249	242
	20	15.0	45.0	47.0	20X2.5	57	SKA20X2.5	305	297
	20	14.0	45.0	47.0	20X3.0	64	SKA20X3	358	349
	20	13.0	45.0	47.0	20X3.5	71	SKA20X3.5	400	400
	20	12.0	45.0	47.0	20X4.0	78	SKA20X4	400	400
	25	19.0	49.5	53.0	25X3.0	89	SKA25X3	294	286
	25	18.0	49.5	53.0	25X3.5	100	SKA25X3.5	337	328
	25	17.0	49.5	53.0	25X4.0	111	SKA25X4	379	369
	25	15.0	49.5	53.0	25X5.0	125	SKA25X5	400	400
	30	24.0	52.0	57.0	30X3.0	113	SKA30X3	249	242
	30	22.0	52.0	57.0	30X4.0	141	SKA30X4	323	314
	30	20.0	52.0	57.0	30X5.0	166	SKA30X5	393	383
	30	18.0	52.0	57.0	30X6.0	188	SKA30X6	400	400
	38	32.0	56.5	64.0	38X3.0	163	SKA38X3	200	195
38	30.0	56.5	64.0	38X4.0	209	SKA38X4	261	254	
38	28.0	56.5	64.0	38X5.0	247	SKA38X5	315	315	
38	26.0	56.5	64.0	38X6.0	270	SKA38X6	315	315	
38	24.0	56.5	64.0	38X7.0	270	SKA38X7	315	315	

¹⁾ Pressure shown = item deliverable

³⁾ L = light series; ⁴⁾ S = heavy series

$$\frac{\text{PN (bar)}}{10} = \text{PN (MPa)}$$

Delivery without nut and ring. Information on ordering complete fittings or alternative sealing materials see page 17.

*Please add the **suffixes** below according to the material/surface required.

Order code suffixes			
Material	Suffix surface and material	Example	Standard sealing material (no additional suffix needed)
Steel		SKA16X2	NBR
Stainless Steel	71	SKA16X271	VIT

SKAR Reducing weld nipple

EO 24° O-ring weld nipple / butt weld

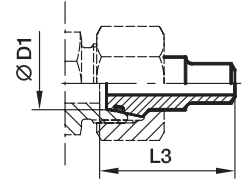
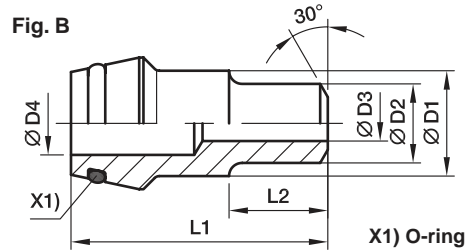
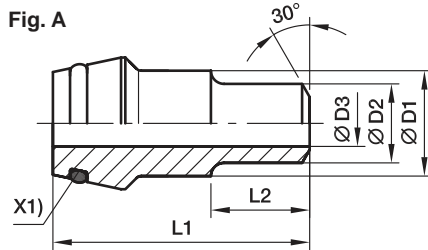

Series	D1	D2	D3	D4	L1	L2	L3	Fig.	Weight g/1 piece	Order code	PN (bar) ¹⁾		
											Steel	Stainless Steel	
L ³⁾ /S ⁴⁾	08	06	3	5	31.0	12	31.5	A	14	SKAR08/06X1.5	528	539	
	10	06	3		32.5	12	33.5	B	15	SKAR10/06X1.5	528	539	
	10	08	5		32.5	12	33.5	A	16	SKAR10/08X1.5	414	424	
	10	08	4	6	32.5	12	33.5	A	17	SKAR10/08X2	528	539	
	12	08	5		32.5	14	33.5	A	18	SKAR12/08X1.5	414	424	
	12	08	4		32.5	14	33.5	B	20	SKAR12/08X2	528	539	
	12	10	7		32.5	14	33.5	A	18	SKAR12/10X1.5	358	349	
S ⁴⁾	16	10	6		39.0	15	40.5	A	43	SKAR16/10X2	400	400	
	16	12	9		39.0	15	40.5	A	45	SKAR16/12X1.5	305	297	
	16	12	8		39.0	15	40.5	A	47	SKAR16/12X2	393	383	
	16	12	7		39.0	15	40.5	A	49	SKAR16/12X2.5	400	400	
	20	12	9		45.0	17	47.0	A	76	SKAR20/12X1.5	305	297	
	20	12	8		45.0	17	47.0	A	78	SKAR20/12X2	393	383	
	20	12	7		45.0	17	47.0	A	80	SKAR20/12X2.5	400	400	
	20	12	6		45.0	17	47.0	A	86	SKAR20/12X3	400	400	
	20	16	12		45.0	17	47.0	A	74	SKAR20/16X2	305	297	
	20	16	11		45.0	17	47.0	A	76	SKAR20/16X2.5	372	362	
	20	16	10		45.0	17	47.0	A	78	SKAR20/16X3	400	400	
	25	12	9		49.5	20	53.0	A	117	SKAR25/12X1.5	305	297	
	25	12	8		49.5	20	53.0	A	121	SKAR25/12X2	393	383	
	25	12	7		49.5	20	53.0	A	125	SKAR25/12X2.5	400	400	
	25	12	6	15	49.5	20	53.0	B	129	SKAR25/12X3	400	400	
	25	16	12		49.5	20	53.0	A	115	SKAR25/16X2	305	297	
	25	16	11		49.5	20	53.0	A	120	SKAR25/16X2.5	372	362	
	25	16	10		49.5	20	53.0	A	123	SKAR25/16X3	400	400	
	25	20	16		49.5	20	53.0	A	94	SKAR25/20X2	249	242	
	25	20	15		49.5	20	53.0	A	104	SKAR25/20X2.5	305	297	
	25	20	14		49.5	20	53.0	A	114	SKAR25/20X3	358	349	
	25	20	12		49.5	20	53.0	A	124	SKAR25/20X4	400	400	
	30	12	9		22	52.0	22	57.0	B	135	SKAR30/12X1.5	305	297
	30	12	8			52.0	22	57.0	B	145	SKAR30/12X2	323	383
	30	12	6	22	52.0	22	57.0	B	155	SKAR30/12X3	400	400	
	30	16	12		52.0	22	57.0	A	166	SKAR30/16X2	305	297	
	30	16	11		52.0	22	57.0	A	176	SKAR30/16X2.5	323	362	
	30	20	16		52.0	22	57.0	A	149	SKAR30/20X2	249	242	
	30	20	15		52.0	22	57.0	A	159	SKAR30/20X2.5	305	297	
	30	20	14		52.0	22	57.0	A	169	SKAR30/20X3	358	349	
	30	20	12		52.0	22	57.0	A	184	SKAR30/20X4	400	400	
	30	25	20		52.0	22	57.0	A	141	SKAR30/25X2.5	249	242	
30	25	19	52.0		22	57.0	A	156	SKAR30/25X3	294	286		
30	25	17	52.0		22	57.0	A	168	SKAR30/25X4	379	369		

SKAR Reducing weld nipple

EO 24° O-ring weld nipple / butt weld

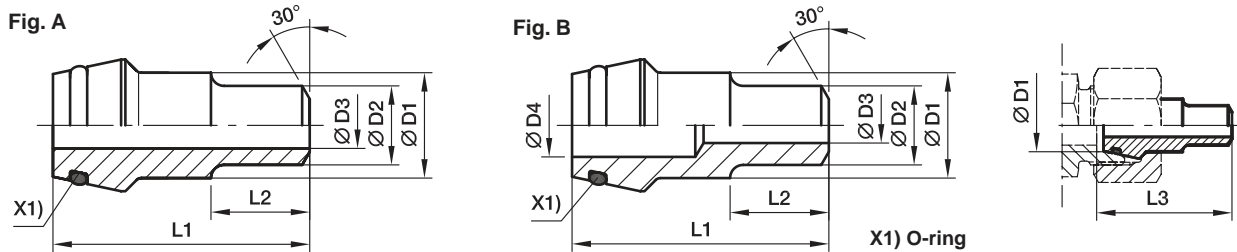

Series	D1	D2	D3	D4	L1	L2	L3	Fig.	Weight g/1 piece	Order code	PN (bar) ¹⁾	
											Steel	Stainless Steel
S ⁴⁾	38	12	9	28	56.5	26	64.0	B	219	SKAR38/12X1.5	305	297
	38	12	8	28	56.5	26	64.0	B	234	SKAR38/12X2	315	315
	38	12	6	28	56.5	26	64.0	B	249	SKAR38/12X3	315	315
	38	16	12		56.5	26	64.0	A	279	SKAR38/16X2	305	297
	38	16	11		56.5	26	64.0	A	294	SKAR38/16X2.5	315	315
	38	16	10		56.5	26	64.0	A	309	SKAR38/16X3	315	315
	38	20	16		56.5	26	64.0	A	263	SKAR38/20X2	249	242
	38	20	15		56.5	26	64.0	A	278	SKAR38/20X2.5	305	297
	38	20	14		56.5	26	64.0	A	293	SKAR38/20X3	315	315
	38	20	12		56.5	26	64.0	A	299	SKAR38/20X4	315	315
	38	25	20		56.5	26	64.0	A	242	SKAR38/25X2.5	249	242
	38	25	19		56.5	26	64.0	A	262	SKAR38/25X3	294	286
	38	25	17		56.5	26	64.0	B	285	SKAR38/25X4	315	315
	38	30	24		56.5	26	64.0	A	256	SKAR38/30X3	249	242
	38	30	22		56.5	26	64.0	A	286	SKAR38/30X4	315	315
38	30	20		56.5	26	64.0	A	316	SKAR38/30X5	315	315	

¹⁾ Pressure shown = item deliverable

³⁾ L = light series; ⁴⁾ S = heavy series

$$\frac{\text{PN (bar)}}{10} = \text{PN (MPa)}$$

Delivery without nut and ring. Information on ordering complete fittings or alternative sealing materials see page 17.

*Please add the **suffixes** below according to the material/surface required.

Order code suffixes			
Material	Suffix surface and material	Example	Standard sealing material (no additional suffix needed)
Steel		SKAR16/12X2	NBR
Stainless Steel	71	SKAR16/12X271	VIT

SKA-ORB Weld nipple (orbital)

EO 24° O-ring weld nipple / butt weld (orbital)

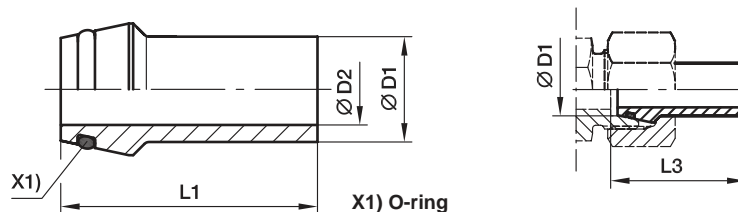

Series	D1	D2	L1	L3	recommended tube	Weight g/1 piece	Order code	PN (bar) ¹⁾ Stainless Steel
L ³⁾ /S ⁴⁾	10	6.0	37.5	38.5	10X1.5	13	SKA10X1.5ORB	358
	12	8.0	37.5	38.5	12X1.5	21	SKA12X1.5ORB	305
	12	8.0	37.5	38.5	12X2.0	255	SKA12X2ORB	393
L ³⁾	18	13.0	38.0	39.0	18X2.0	43	SKA18X2ORB	290
	22	17.0	38.5	39.5	22X2.0	50	SKA22X2ORB	250
	28	22.0	41.5	42.5	28X2.0	69	SKA28X2ORB	204
	42	36.0	47.5	50.0	42X3.0	160	SKA42X3ORB	182
S ⁴⁾	16	12.0	39.0	40.5	16X2.0	310	SKA16X2ORB	305
	20	14.0	45.0	47.0	20X3.0	640	SKA20X3ORB	358
	25	19.0	49.5	53.0	25X3.0	890	SKA25X3ORB	294

¹⁾ Pressure shown = item deliverable

³⁾ L = light series; ⁴⁾ S = heavy series

$\frac{PN \text{ (bar)}}{10} = PN \text{ (MPa)}$

Delivery without nut and ring. Information on ordering complete fittings or alternative sealing materials see page 17.

*Please add the **suffixes** below according to the material/surface required.

Order code suffixes			
Material	Suffix surface and material	Example	Standard sealing material (no additional suffix needed)
Stainless Steel	71	SKA16X2ORB71	VIT

SKA-RB Tube bend weld nipple

EO 24° O-ring weld nipple / butt weld

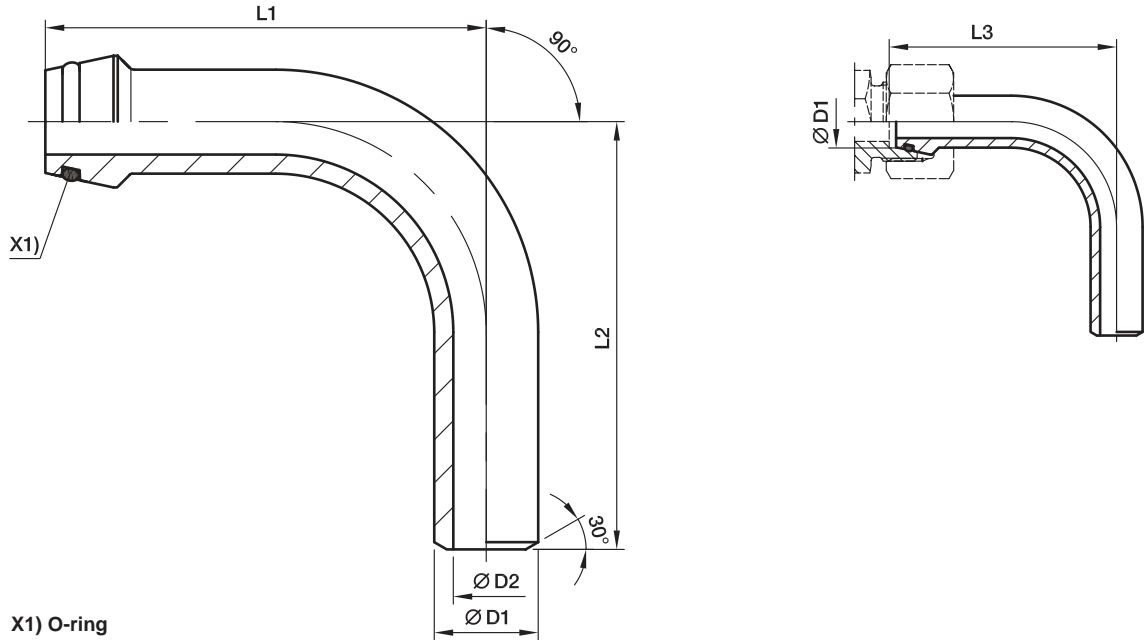

Series	D1	D2	L1	L2	L3	recommended tube	Weight g/1 piece	Order code	PN (bar) ¹⁾	
									Steel	Stainless Steel
S ⁴⁾	10	6	49	45	50.0	10X2	38	SKA10X2RB	460	447
	12	7	51	50	52.0	12X2.5	50	SKA12X2.5RB	476	463
	16	10	67	60	68.5	16X3	105	SKA16X3RB	400	400
	20	12	85	65	87.0	20X4	217	SKA20X4RB	400	400
	25	17	85	85	88.5	25X4	295	SKA25X4RB	379	369
	25	15	85	85	88.5	25X5	353	SKA25X5RB	400	400
	30	22	111	110	116.0	30X4	469	SKA30X4RB	323	314
	30	20	111	110	116.0	30X5	568	SKA30X5RB	393	383
	38	28	136	130	143.5	38X5	876	SKA38X5RB	315	315
	38	26	136	130	143.5	38X6	1045	SKA38X6RB	315	315

¹⁾ Pressure shown = item deliverable

⁴⁾ S = heavy series

$$\frac{PN \text{ (bar)}}{10} = PN \text{ (MPa)}$$

Delivery without nut and ring. Information on ordering complete fittings or alternative sealing materials see page I7.

*Please add the **suffixes** below according to the material/ surface required.

Order code suffixes			
Material	Suffix surface and material	Example	Standard sealing material (no additional suffix needed)
Steel		SKA16X3RB	NBR
Stainless Steel	71	SKA16X3RB71	VIT

OR O-ring for weld nipple

For Type: SKA, SKAR, SKA-RB

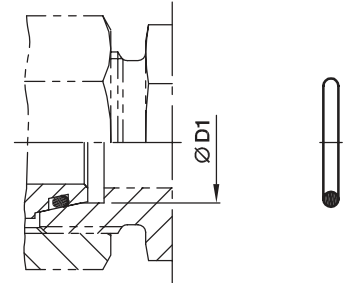

Series	D1 	O-ring NBR Shore-Hardness approx. 90	O-ring FKM Shore-Hardness approx. 90
L ³⁾	06	OR4.5X1.5X	OR4.5X1.5VITX
	08	OR6.5X1.5X	OR6.5X1.5VITX
	10	OR8X1.5X	OR8X1.5VITX
	12	OR10X1.5X	OR10X1.5VITX
	15	OR12X2X	OR12X2VITX
	18	OR15X2X	OR15X2VITX
	22	OR20X2X	OR20X2VITX
	28	OR26X2X	OR26X2VITX
	35	OR32X2.5X	OR32X2.5VITX
	42	OR38X2.5X	OR38X2.5VITX
S ⁴⁾	06	OR4.5X1.5X	OR4.5X1.5VITX
	08	OR6.5X1.5X	OR6.5X1.5VITX
	10	OR8X1.5X	OR8X1.5VITX
	12	OR10X1.5X	OR10X1.5VITX
	14	OR11X2X	OR11X2VITX
	16	OR13X2X	OR13X2VITX
	20	OR16.3X2.4X	OR16.3X2.4VITX
	25	OR20.3X2.4X	OR20.3X2.4VITX
	30	OR25.3X2.4X	OR25.3X2.4VITX
	38	OR33.3X2.4X	OR33.3X2.4VITX

³⁾ L = light series; ⁴⁾ S = heavy series



EO[®] Ermeto Original
High Pressure
Hydraulic Flanges





Table of contents

	Page
Introduction	4
Design and construction	4
Methods of connection	5
How flange connections work	6
Assembly of flanges	7
Technical data	8
Order codes screws and O-rings	9
Features, advantages and benefits	10
How to order	11
Visual index	12
SAE Flange clamps	15
SAE Flange adapters	
EO 24° cone end	20
BSPP 60° cone end	24
Male NPT thread	26
O-Lok® ORFS end	27
Triple-Lok® 37° flare end	30
Butt weld end	33
Socket weld end	38
SAE 4 bolt flanges	
BSPP 60° cone end	41
Female NPT thread	45
Female metric and UN/UNF thread	48
EO 24° cone end	50
BSPP 60° cone end	52
Triple-Lok® 37° flare end	54
O-Lok® ORFS end	56
Butt weld end	58
Socket weld end	61
Complete flange connections	65
SAE Flange accessories	68
SAE Junction blocks	74
Gear pump flanges	
EO 24° cone end	78
Male/Female BSPP thread	81
Butt weld end	83
Special pump size flanges	84
Aluminium flanges	87
ISO 6164 Square flanges	89
Cetop square flanges	94
Ball valve flanges	99



Introduction

The 4 bolt flange connections conforming to SAE J518 and ISO 6162-1 and -2 are proven, leak-free connections, especially suited for larger sizes, high pressures and assembly in tight quarters. Threaded port connections such as SAE straight thread O-ring and ISO 6149 are reasonably easy to assemble and provide 6000 psi and higher pressure capability up to size 12 (M27). Beyond this size the pressure rating starts to decrease and assembly torques increase rapidly.

The 4 bolt flange port connections provide ability to connect larger sizes and achieve higher-pressure capability at reasonable assembly torques. Because of the lower assembly torques compared to an equivalent size threaded port, these connections are well suited for tight quarters where wrench clearances are limited.

Design and construction

Parker 4 bolt flange products are designed to provide different methods of connecting a tube, hose, pipe or another fitting to the SAE standard 4-bolt flange port.

Flange fittings – All Parker flange fittings, except for those with square mounting hole pattern, are designed to conform to O-ring groove, bolt holes and bolt pattern dimensions of either Code 61 or Code 62 of SAE J518 and ISO 6162-1 or ISO 6162-2.

The flange adapters and 4 bolt flange block fittings have O-ring grooves conforming to dimensions in ISO 6162-1 and -2 (SAE J518). The 4 bolt flange block fittings have through holes for the mounting bolts, again conforming to ISO 6162-1 and -2 (SAE J518).

The counter fittings have a flat face (no O-ring groove) and the mounting holes are tapped. Where these fittings are used, the seal is in the mating part (flange adapter, flange hose fitting, flange block fitting, etc.) as shown in Fig. 1.

Dimensions other than the O-ring groove, bolt holes, bolt pattern, and the flange foot print are not governed by any industry standard. However, Parker product design follows common industry practice and sound engineering.

Fig. 1 – Flange pad fitting

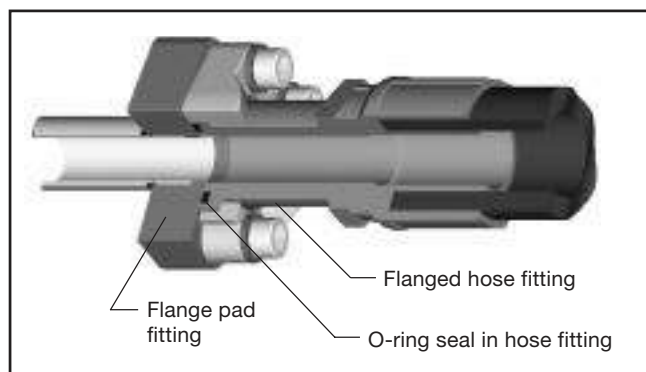

Flange clamps – Clamps are used for providing the holding power to the 4 bolt flange connection. They are offered in split and captive (one-piece) versions. The captive ones are also offered with either drilled or tapped bolt holes. The captive flange clamp with tapped holes is used while connecting a tube to another tube or a hose.

Parker flange clamps are forged for higher strength and durability. They meet all requirements of ISO 6162-1 and -2 (SAE J518). The split clamps make it easy to assemble the connection in close quarters. They also make removal of the flange head component, such as a hose assembly, easy by loosening all four bolts and removing one clamp half.

Junction block tees – These are solid block union fittings to connect two/three tube/hose assemblies using 4 bolt flange connection, at a junction, to SAE 4 bolt flange port, or three tube/hose assemblies to each other.

Connector plate – Connector plate is used as a middle plate to connect two flange heads with O-ring grooves, such as two hose assemblies with flange connection ends. The flat surface of the plate provides sealing surface on each side for the O-ring housed in the hose ends.

Spacer plate – Spacer plate provides access to the system fluid via the gage port on the side. The plate is sandwiched in the flange connection to provide this access.

Plugs – Plugs provide a means to block off the 4 bolt flange port with and without clamps, and to plug the end of a pipe (via welding).

Methods of connection – Parker 4 bolt flange products

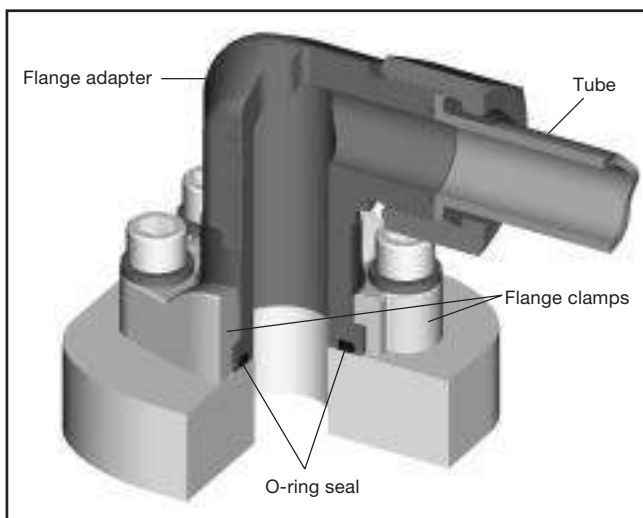

Connecting tube and hose via a threaded tube/hose end connection: The flange adapters provide means of connecting tubes or hoses to a 4 bolt flange port via threaded connection such as Seal-Lok (ORFS), Triple-Lok® (37° flare), etc.

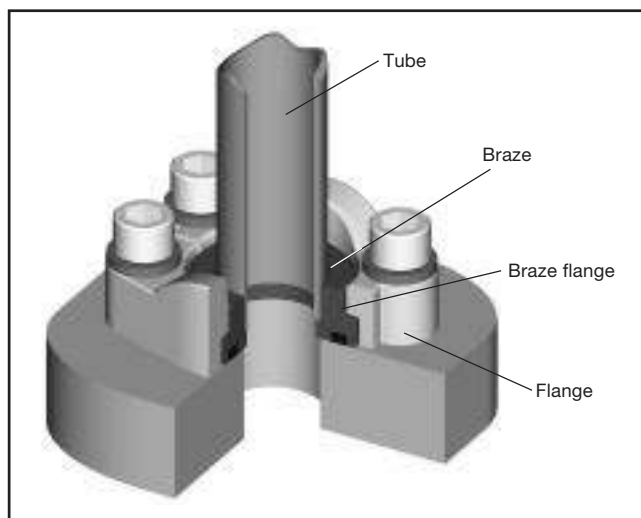

Connecting tubes via brazing. The braze flange head fittings for Code 61 and Code 62 connections provide the means of connecting tubes directly to 4 bolt flange ports.

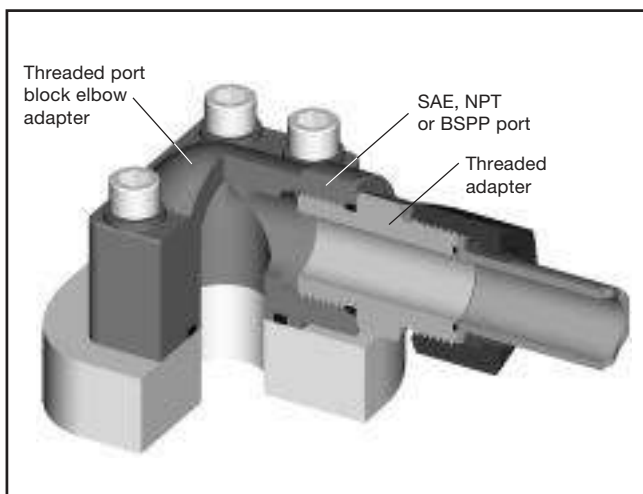

Connecting tube, hose and pipe via threaded port connection. The flange head and flange block conversion adapters provide the means of converting a 4 bolt flange port to either SAE, NPT or BSPP port. A user can then use appropriate threaded adapters to connect tube and hose, or connect threaded pipe directly into NPT and BSPP ports.

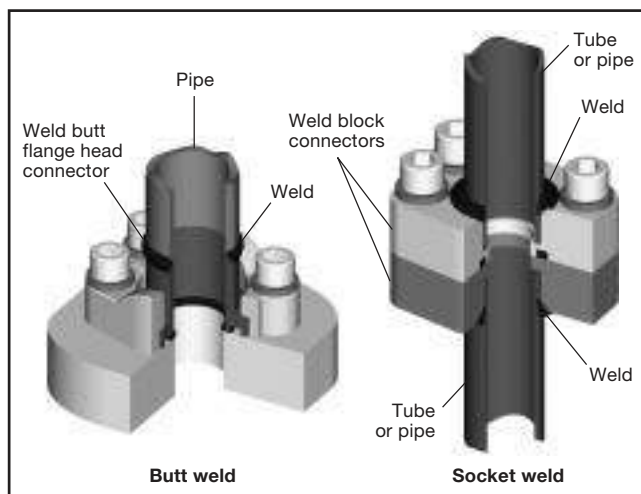

Connecting tube and pipe via welding. The flange head and flange block weld fittings provide the means of connecting tubes and pipes to 4 bolt flange port via socket welding for tubes and socket and butt welding for pipes.

M

How flange connections work

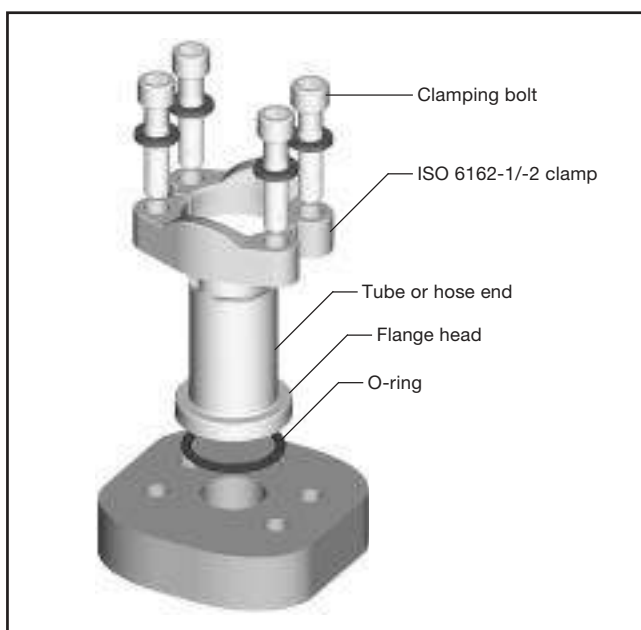

4 bolt flange connection ISO 6162-1 and -2 (SAE J518) is a proven leak-free connection, especially suited for larger sizes. As a result, it has achieved worldwide acceptance.

The connection's success is in its simplicity. It is a static face seal using a high durometer O-ring for the seal and clamps and bolts for holding power as shown here.

The (O-ring) seal is compressed between the bottom of the groove in the flange head and the flat surface of the port or flange pad, providing a reliable soft seal. The alternate seal plate has a high durometer bonded rubber seal on the inside edge, which compresses between the two flat surfaces, providing a soft seal with the same reliability. A metal-to-metal contact at the outer face of the flange with the port face keeps the seal from extruding under pressure. This metal-to-metal contact is maintained by the clamping force provided by tightening of the bolts via the clamps.

This simple design provides several advantages over threaded port connections, such as NPT, SAE, BSPP, ISO 6149, etc., in larger sizes:

- Ability to connect up to 5 inch O.D. tube (ISO 6162-1 only)
- Much lower tightening torque required from the four bolts compared to that required for equivalent size threaded port.
- Less tightening torque means smaller wrenches and wrench swing clearances – providing ease of assembly in tight quarters.
- Up to 6000 psi capability through 2" size (ISO 6162-2 only)
- Single seal point between tube/pipe/hose assembly and the port
- Ease of disassembly through use of split clamps

The connection has one disadvantage – it requires a larger area (foot print) on the component than an equivalent threaded port.

Flanges



Assembly of flanges

- SAE flange adapters
- SAE 4 bolt flanges
- Gear pump flanges
- CETOP square flanges

1



- Make sure sealing surfaces are free of burrs, nicks, scratches or any contamination
- Lubricate the O-ring with system fluid or compatible lubricant

2



- Position flange and clamp halves
- Place lock washers on bolts and bolt through clamp halves

3

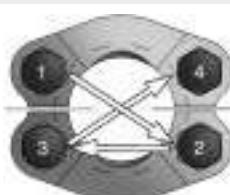

- Hand tighten bolts
- Torque bolts in diagonal sequence in small increments to the appropriate torque level listed in chart

4

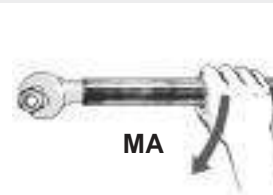

- Tighten bolts according to chart

3000 PSI Series (Code 61) Flange recommended screws torque

Dash size	Flange size	Inch screws (J518)	Torque Nm ¹⁾	Metric screws (ISO 6162)	Torque Nm ¹⁾
13	1/2	5/16-18	24	M8	24
19	3/4	3/8-16	43	M10	50
25	1	3/8-16	43	M10	50
32	1-1/4	7/16-14	70	M12*	50
38	1-1/2	1/2-13	105	M12	92
51	2	1/2-13	105	M14*	135
64	2-1/2	1/2-13	105	M12	92
76	3	5/8-11	210	M16	210
89	3-1/2	5/8-11	210	M16	210
102	4	5/8-11	210	M16	210
127	5	5/8-11	210	M16	210

*Does not meet ISO 6162 specification

6000 PSI Series (Code 62) Flange recommended screws torque

Dash size	Flange size	Inch screws (J518)	Torque Nm ¹⁾	Metric screws (ISO 6162)	Torque Nm ¹⁾
13	1/2	5/16-18	24	M8	24
19	3/4	3/8-16	43	M10	50
25	1	7/16-14	70	M12	92
32	1-1/4	1/2-13	105	M14*	130
38	1-1/2	5/8-11	210	M16	210
51	2	3/4-10	360	M20	400

*Does not meet ISO 6162 specification

Hydraulic Flange recommended screws torque

Socket screw bolt circle (LK)	Socket head cap screws	Tightening torques Nm ¹⁾
LK30	M6	10
LK35	M6	10
LK40	M6	10
LK51	M10	49
LK55	M8	25
LK56	M10	49
LK62	M10	49
LK72.5	M12	85

1) Tolerances: max. 10%
min. 0%



Technical data

Used screws

SAE Flanges according to ISO 6162-1 and -2 (SAE J518)

- metric screws according to
DIN 912-8.8 (ISO 4762-8.8) or
DIN 912-10.9 (ISO 4762-10.9)¹
- UNC screws according to ASA B 18.3

Square flanges according to ISO 6164 (1994) and Cetop

- metric screws according to
DIN 912-8.8 (ISO 4762-8.8) or
DIN 912-10.9 (ISO 4762-10.9)¹

Gear pump flanges

- metric screws according to
DIN 912-8.8 (ISO 4762-8.8)

¹ Screws with grade 10.9/12.9 are to be used, when the material for the flanges is high tempered!

Used sealing

Materials

Flanges according **SAE J518 (ISO 6162-1 and -2)**, **ISO 6164**, **Cetop** and all **gear pump flanges** in this catalogue are sealed with an O-ring. The seals of our flanges are out of the following materials:

- NBR (e.g. perbunan) 90 durometer is our standard seal material for hydraulic **steel** flange applications.
- FKM (e.g. viton) 85 or 90 durometer is our standard seal material for hydraulic **stainless steel** flange applications.

Viton = registered trademark of Bayer
Perbunan = registered trademark of DuPont

Dimensions

O-ring dimensions of ISO 6164 flanges, Cetop flanges and gear pump flanges are shown direct on the product catalogue page. For all flanges according to **SAE J518 (ISO 6162-1 and -2)** the O-ring dimension are according to the following table:

Nominal flange size	Nominal inch tube size (in inches)	ISO 3601-1 O-ring	SAE J515 O-ring	SAE J515 O-ring size number
13	1/2	19 3.55	18.64 3.53	210
19	3/4	25 3.55	24.99 3.53	214
25	1	32.5 3.55	32.92 3.53	219
32	1 1/4	37.5 3.55	37.69 3.53	222
38	1 1/2	47.5 3.55	47.22 3.53	225
51	2	56 3.55	56.74 3.53	228
64	2 1/2	69 3.55	69.44 3.53	232
76	3	85 3.55	85.32 3.53	237
89	3 1/2	97.5 3.55	98.02 3.53	241
102	4	112 3.55	110.72 3.53	245
127	5	136 3.55	136.12 3.53	253

Pressure rates

The maximum recommended working pressure is indicated at each single article.

Before using a part, please take notice of the pressure indications.

All pressure indications are based on a working temperature from -20° celsius up to +100° celsius (resp. ambient temperature from -40° celsius up to +120° celsius). Outside of this temperature range the physical properties of the used material is impacted and the maximum recommended working pressure is reduced.

The indicated working pressure refer only on the flange itself. For the used tubes, fittings and connections the pressure indications of the specific manufacturer is the determinative factor.

Used materials

SAE flanges according to ISO 6162-1 and -2 (SAE 518)

Flange clamps, flange adapter and forged 4 bold flanges are made of the material ST 52.3 or compatible for **steel** construction. For **stainless steel** constructions we are using for flange clamps and 4 bolt forged flanges the material 1.4404 (316L) or compatible and for flange adapters the material 1.4571 (316Ti) or compatible.

Square flanges according to ISO 6164 (1994) and Cetop

Steel construction: ST52.3, C40 or compatible
Stainless steel construction: 1.4571 (316Ti) or compatible

Gear pump flanges

Steel forged construction: GTW40 or compatible
Steel construction: ST52.3, 11SMnPb30 or compatible

If different materials are used for manufacturing, this will be shown on the catalogue product page.

Surface protection

All surface order possibilities are described on each catalogue page!

Surface possibilities are:

1. blanc oil dipped
2. zinc yellow plated surface protection type A3C according to DIN EN ISO 4042
3. silver surface protection type A3K according to DIN EN ISO 4042
4. chrome⁶-free surface protection type CF with better corrosion resistance than A3C surface protection

Order codes screws and O-rings

Screws for flanges

according ISO 6162-1 and -2 (SAE J518)

Nominal flange size			Screws for flange halves		Screws for full flanges	
Series	ISO	SAE	metr. Order code	UNC Order code	metr. Order code	UNC Order code
3000 PSI	13	1/2	ZYLS8X25A3CX	UNC5/16-18X11/4	ZYLS8X30A3CX	UNC5/16-18X11/4
3000 PSI	19	3/4	ZYLS10X30A3CX	UNC3/8-16X11/4	ZYLS10X35A3CX	UNC3/8-16X11/2
3000 PSI	25	1	ZYLS10X30A3CX	UNC3/8-16X11/4	ZYLS10X35A3CX	UNC3/8-16X11/2
3000 PSI	32	1 1/4	ZYLS10X30A3CX	UNC7/16-14X11/2	ZYLS10X40A3CX	UNC7/16-14X11/2
3000 PSI	32	1 1/4	ZYLS10X35A3CX *	—	—	—
3000 PSI	32	1 1/4	ZYLS12X35A3CX *	—	—	—
3000 PSI	38	1 1/2	ZYLS12X35A3CX	UNC1/2-13X11/2	ZYLS12X45A3CX	UNC1/2-13X13/4
3000 PSI	38	1 1/2	ZYLS14X35A3CX *	—	—	—
3000 PSI	51	2	ZYLS12X35A3CX	UNC1/2-13X11/2	ZYLS12X45A3CX	UNC1/2-13X13/4
3000 PSI	51	2	ZYLS14X35A3CX *	—	—	—
3000 PSI	64	2 1/2	ZYLS12X40A3CX	UNC1/2-13X11/2 *	ZYLS12X45A3CX	UNC1/2-13X13/4
3000 PSI	64	2 1/2	ZYLS14X35A3CX *	UNC1/2-13X13/4	—	—
3000 PSI	76	3	ZYLS16X50A3CX	UNC5/8-11X2 *	ZYLS16X55A3CX	UNC5/8-11X21X4
3000 PSI	76	3	ZYLS16X45A3CX *	UNC5/8-13/4	—	—
3000 PSI	89	3 1/2	ZYLS16X50A3CX	UNC5/8-11X2 *	ZYLS16X55A3CX	UNC5/8-11X21X4
3000 PSI	89	3 1/2	ZYLS16X45A3CX *	—	—	—
3000 PSI	102	4	ZYLS16X50A3CX	UNC5/8-11X2	ZYLS16X55A3CX	UNC5/8-11X21X4
3000 PSI	102	4	ZYLS16X45A3CX *	—	—	—
3000 PSI	127	5	ZYLS16X50A3CX *	UNC5/8-11X21/4	ZYLS16X55A3CX	UNC5/8-11X21X4
3000 PSI	127	5	ZYLS16X55A3CX	UNC5/8-11X2 *	—	—
Series	ISO	SAE	metr.	UNC	metr.	UNC
6000 PSI	13	1/2	ZYLS8X30A3CX	UNC5/16-18X11/4	ZYLS8X30A3CX	UNC5/16-18X11/4
6000 PSI	19	3/4	ZYLS10X35A3CX	UNC3/8-16X11/2	ZYLS10X35A3CX	UNC3/8-16X11/2
6000 PSI	25	1	ZYLS12X45A3CX	UNC7/16-14X11/2 *	ZYLS12X45A3CX	UNC7/16-14X11/2
6000 PSI	25	1	—	UNC7/16-14X13/4	—	—
6000 PSI	32	1 1/4	ZYLS14X50A3CX *	UNC1/2-13X13/4	ZYLS14X45A3CX	UNC1/2-13X13/4
6000 PSI	32	1 1/4	ZYLS12X45A3CX	—	—	—
6000 PSI	38	1 1/2	ZYLS16X55A3CX	UNC5/8-11X21/4	ZYLS16X55A3CX	UNC5/8-11X21X4
6000 PSI	38	1 1/2	—	UNC5/8-11X2 *	—	—
6000 PSI	51	2	ZYLS20X65A3CX	UNC3/4-10X23/4	ZYLS20X70A3CX	UNC3/4-10X23X4
6000 PSI	51	2	ZYLS20X70A3C	UNC3/4-10X21/2 *	—	—
6000 PSI	64	2 1/2	ZYLS24X75A3CX	—	ZYLS24X90A3CX	—
6000 PSI	76	3	ZYLS30X90A3CX	—	ZYLS30X110A3CX	—

* = are not implemented in the ISO 6162 -1 and ISO 6162-2.

Screws for hydraulic flanges

(BFG, BFW)

Type	Screws Order code	Description
BFG (10L-28L)	ZYLS6X22A3CX	4 Stück
BFG (20S)	ZYLS8X25A3CX	4 Stück

Type	LK	Screws		Description
		Order code	Order code	
BFW 10L	35	ZYLS6X22A3CX	ZYLS6X35A3CX	2 Pieces of each screws
BFW 12L	35	ZYLS6X22A3CX	ZYLS6X35A3CX	2 Pieces of each screws
BFW 15L	35	ZYLS6X22A3CX	ZYLS6X35A3CX	2 Pieces of each screws
BFW 16S	35	ZYLS6X22A3CX	ZYLS6X40A3CX	2 Pieces of each screws
BFW 20S	35	ZYLS6X22A3CX	ZYLS6X45A3CX	2 Pieces of each screws
BFW 15L	40	ZYLS6X22A3CX	—	4 Pieces
BFW 18L	40	ZYLS6X22A3CX	—	4 Pieces
BFW 22L	40	ZYLS6X22A3CX	—	4 Pieces
BFW 28L	40	ZYLS6X20A3CX	ZYLS6X50A3CX	2 Pieces of each screws
BFW 35L	40	ZYLS6X22A3CX	ZYLS6X60A3CX	2 Pieces of each screws
BFW 20S	40	ZYLS6X22A3CX	ZYLS6X45A3CX	2 Pieces of each screws
BFW 35L	55	ZYLS8X25A3CX	ZYLS8X60A3CX	2 Pieces of each screws
BFW 42L	55	ZYLS8X25A3CX	ZYLS8X70A3CX	2 Pieces of each screws
BFW 20S	55	ZYLS8X25A3CX	ZYLS8X50A3CX	2 Pieces of each screws
BFW 25S	55	ZYLS8X25A3CX	ZYLS8X55A3CX	2 Pieces of each screws
BFW 30S	55	ZYLS8X25A3CX	ZYLS8X50A3CX	2 Pieces of each screws

O-rings for flanges

SAE J518

ISO (DN)	SAE (in)	O-ring	
		NBR Order code	FKM Order code
13	1/2	OR18.64X3.53X	OR18.64X3.53VITX
19	3/4	OR25X3.53X	OR25X3.53VITX
25	1	OR32.92X3.53X	OR32.92X3.53VITX
32	1 1/4	OR37.69X3.53X	OR37.69X3.53VITX
38	1 1/2	OR47.22X3.53X	OR47.22X3.53VITX
51	2	OR56.75X3.53X	OR56.75X3.53VITX
64	2 1/2	OR69.44X3.53X	OR69.44X3.53VITX
76	3	OR85.32X3.53X	OR85.32X3.53VITX
89	3 1/2	OR98.02X3.53X	OR98.02X3.53VITX
102	4	OR110.72X3.53X	OR110.72X3.53VITX
127	5	OR136.12X3.53X	OR136.12X3.53VITX

O-rings for hydraulic flanges

(BFG, BFW)

LK	O-ring size	Order code
35	20 2.5	OR20X2.5X
40	26 2.5	OR26X2.5X
55	32 2.5	OR32X2.5X



Features, advantages and benefits

- 1. Manufacture** – Code 61/62 fittings conform to SAE J518 and ISO 6162. This specification controls dimensions and tolerances of Code 61/62 port connections.
- 2. Available configurations** – Over 60 different configurations are standard in a range of sizes. The breadth of product provides flexibility in plumbing to insure the best solution possible.
- 3. Materials** – All configurations are available as standard in steel, with commonly used styles available in stainless steel.
- 4. Available sizes** – Most configurations are available as standard in 1/2" through 2" with sizes as large as 5" available in some styles.
- 5. Construction** – Parker offers a completely forged steel product line to insure our products hold up in the most rigorous applications.
- 6. Envelope size** – Forged construction provides a compact design as compared flanges machined from block steel.
- 7. Pressure ratings** – Code 61/62 fittings and flanges have pressure ratings up to 6000 psi. The recommended working pressure can be found directly on each catalogue page. This is a quick and easy way to verify the part in question meets the application pressure requirements.
- 8. Flange kits** – To reduce ordering and assembly errors, kits that include mounting hardware (bolts, O-ring, and if needed flange halves) are available.
- 9. Mounting hardware** – Bolts used in mounting kits are designated at least grade 8.8 to provide long dependable use.

How to order

SAE Flange adapters



WFS SAE 90° Elbow flange adapter

SAE Flange / EO 24° cone end
(ISO 6162-1/-2)

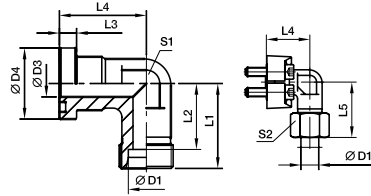

3000 PSI Series

Nom. flange size SAE (in)	ISO (DN)	D1 ¹⁾	D3	D4	L1	L2	L3	L4	L5	S1	S2	Screws		Weight (steel) kg/piece	Order code*	PN (bar) ²⁾	
												(metr.)	(unc.)			A3C	71
1/2	13	12S	12	30.2	50	43.0	6.7	44	57	22	24	M 8x25	5/16x1 1/4	0.38	WFS32/12S	210	210
1/2	13	15L	12	30.2	36	29.0	6.7	36	44	24	27	M 8x25	5/16x1 1/4	0.40	WFS32/15L	315	315
1/2	13	16S	12	30.2	38	29.5	6.7	36	48	24	30	M 8x25	5/16x1 1/4	0.43	WFS32/16S	350	350
1/2	13	18L	12	30.2	50	42.5	6.7	44	59	22	32	M 8x25	5/16x1 1/4	0.44	WFS32/18L	315	315
3/4	19	16S	19	38.1	64	55.5	6.7	53	74	27	30	M10x30	3/8x1 1/4	0.60	WFS33/16S	350	350
3/4	19	18L	19	38.1	39	31.5	6.7	42	48	30	32	M10x30	3/8x1 1/4	0.66	WFS33/18L	315	315
3/4	19	22L	19	38.1	41	33.5	6.7	42	50	30	36	M10x30	3/8x1 1/4	0.66	WFS33/22L	160	160
3/4	19	20S	19	38.1	43	32.5	6.7	42	54	30	36	M10x30	3/8x1 1/4	0.76	WFS33/20S	350	350
3/4	19	25S	19	38.1	45	33.0	6.7	42	57	30	46	M10x30	3/8x1 1/4	0.76	WFS33/25S	350	350
1	25	20S	25	44.5	65	54.5	8.0	60	76	34	36	M10x30	3/8x1 1/4	0.76	WFS34/20S	350	350
1	25	22L	25	44.5	65	49.5	8.0	60	74	34	36	M10x30	3/8x1 1/4	0.76	WFS34/22L	350	350
1	25	28L	25	44.5	44	36.5	8.0	45	53	36	41	M10x30	3/8x1 1/4	0.76	WFS34/28L	160	160
1	25	25S	25	44.5	48	36.5	8.0	45	57	36	46	M10x30	3/8x1 1/4	0.76	WFS34/25S	350	350
1	25	30S	25	44.5	50	36.5	8.0	45	63	36	50	M10x30	3/8x1 1/4	0.76	WFS34/30S	160	160
1 1/4	32	35L	29	50.8	57	46.5	8.0	50	68	41	50	M10x35	3/8x1 1/2	1.38	WFS35/35L/10	200	200
1 1/4	32	25S	29	50.8	55	43.0	8.0	60	67	41	46	M10x35	3/8x1 1/2	1.38	WFS35/25S/10	200	200
1 1/4	32	30S	29	50.8	57	43.5	8.0	50	70	41	50	M10x35	3/8x1 1/2	1.40	WFS35/30S/10	200	200
1 1/4	32	38S	29	50.8	59	43.0	8.0	50	74	46	60	M10x35	3/8x1 1/2	1.53	WFS35/38S	200	200
1 1/4	32	38S	29	50.8	59	43.0	8.0	50	74	46	60	M10x35	3/8x1 1/2	1.55	WFS35/38S	160	160
1 1/2	38	42L	36	60.3	58	47.0	8.0	55	70	46	60	M12x40	7/16x1 1/2	1.60	WFS36/42L	160	160
1 1/2	38	38S	36	60.3	64	48.0	8.0	55	79	46	60	M12x35	1/2x1 1/2	1.95	WFS36/38S	200	200

¹⁾ Pressure shown = Item deliverable

²⁾ L = light series; S = heavy series

PN (bar)
10 = PN (MPa)

Delivery without nut and ring.
Information on ordering complete fittings or alternative sealing materials see page 9.

*Please add the suffixes below to the material / surface required

Material	Example only flange adapter	Example incl. splitflanges, metr. screws and O-ring	Standard sealing material (no additional suffix needed)
Steel, zinc plated, chrome ³⁾	WFS32/16SCFX	WFS32/16SOMDCF	NBR
Steel, zinc yellow plated	WFS32/16SA3CX	WFS32/16SOMDA3C	NBR
Stainless steel	WFS32/16S71X	WFS32/16SOMD71	VIT



Catalogue 4039/UK

The right way to order made easy!

Step 1

Selecting order code

- All flange sizes available in our program of supply are clearly listed in the index at the front of this catalogue.
- Open the catalogue at the corresponding page containing detailed information of the product of your choice.
- Select the required flange size!
The basic order code is printed in bold type on the right-hand side of the table of dimensions.
Example: **WFS34/30S**.

Step 2

Selecting material and surface . . .

Now simply add the corresponding ID code for the surface and material variant of the product you require to the basic order code.
This ID code is contained in the table printed at the bottom of every page.

Example: WFS34/30S + A3CX = **WFS34/30SA3CX**

4. Ordering single parts

Example: single part, yellow galvanized
WFS34/30S + A3CX = WFS34/30SA3CX

5. Ordering complete types

Example: order incl. splitflanges, metric-screw pack and O-ring
WFS34/30S + OMDA3C = WFS34/30SOMDA3C

6. Order containing nut and cutting ring

Example: flange incl. splitflanges, metric-screw pack, O-ring, nut and cutting ring
WFS34/30S + A3C = WFS34/30SA3C

7. Order with functional nut

Example: flange incl. splitflanges, metric-screw pack, O-ring, nut and functional nut
WFS34/30 (+Z) S + A3C = WFS34/30ZSA3C

8. Other sealing materials

Example: flange made of steel incl. splitflanges, metric-screw pack and O-ring made of **FKM** (for example, Viton).
WFS34/30S + VITOMDA3C = WFS34/30SVITOMDA3C

Example: flange made of stainless steel incl. splitflanges, metric-screw pack and O-ring made of **NBR** (for example, Perbunan).
WFS34/30S + NBRMD71 = WFS34/30SNBRMD71

Viton = registered trademark of Bayer
Perbunan = registered trademark of DuPont

The corresponding order variant is contained in the table printed at the bottom of every page in the catalogue.

Visual index

SAE Flange clamps



FHS – p. M15

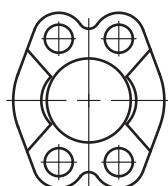

FUS – p. M16

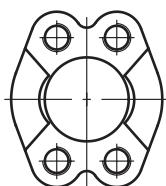

FUSM – p. M17

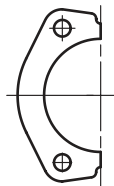

FHSF – p. M18

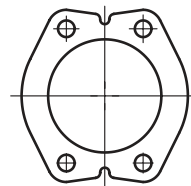

FUSF – p. M19

SAE Flange adapters

EO 24° cone end

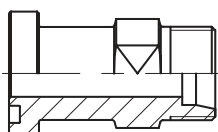

GFS – p. M20

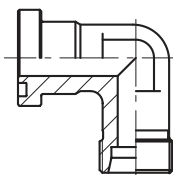

WFS – p. M22

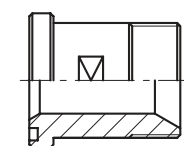

GFS-G – p. M24

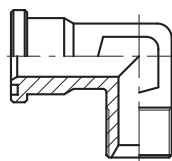

WFS-G – p. M25

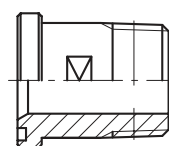

GFS-N – p. M26

BSPP 60° cone end

Male NPT thread

O-Lok® ORFS end

Triple-Lok® 37° flare end

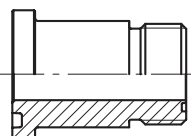

L(O)HQ – p. M27

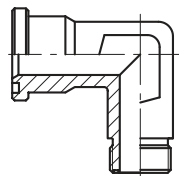

L(O)EMQ – p. M28

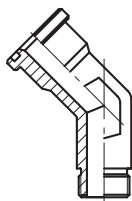

L(O)VQ – p. M29

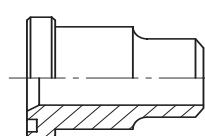

XHQ – p. M30

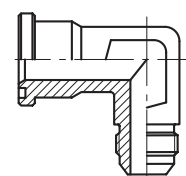

XEMQ – p. M31

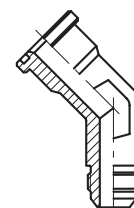

XVQ – p. M32

Butt weld end

Socket weld end

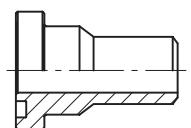

ASR – p. M33

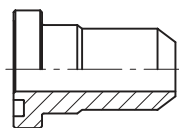

AS – p. M34

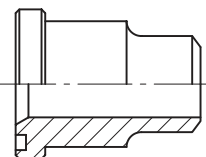

ASL – p. M36

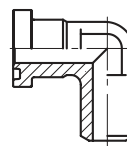

WAS – p. M37

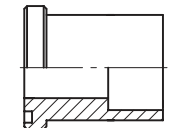

ES – p. M38

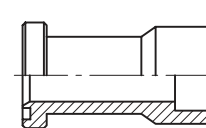

ESL – p. M40

SAE 4 bolt flanges

BSPP 60° cone end

Female NPT thread

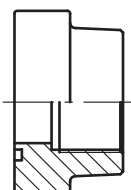

PFF-G – p. M41

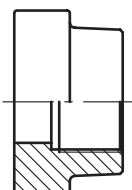

PCFF-G – p. M42



PAFSF-G – p. M43

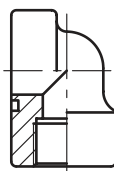

PEFF-G – p. M44

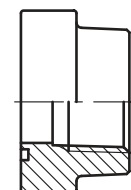

PFF-N – p. M45

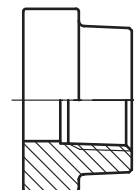

PCFF-N – p. M46

Female metric and UN/UNF thread

EO 24° cone end

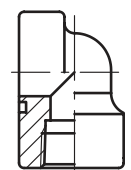

PEFF-N – p. M47

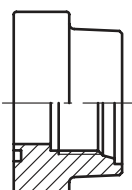

PAFS-M – p. M48

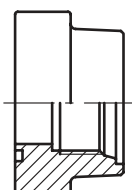

PAFS-U – p. M49

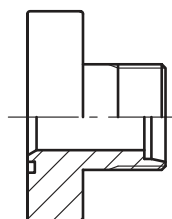

PFF-..S/L – p. M50

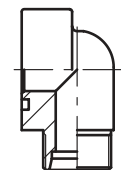

PAFG-90M – p. M51

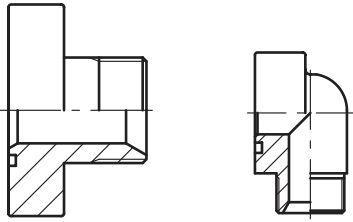
BSPP 60° cone end

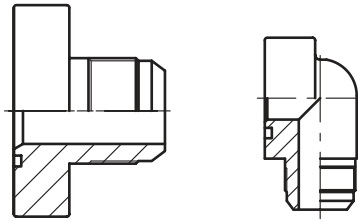
PAFG-G – p. M52 **PAFG-90G** – p. M53

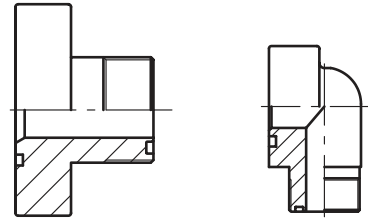
Triple-Lok® 37° flare end

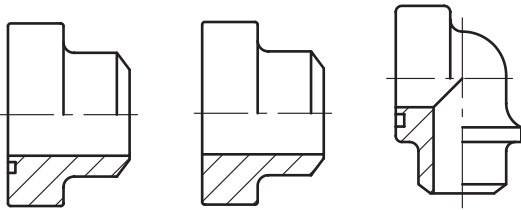
PAFG-X – p. M54 **PAFG-90X** – p. M55

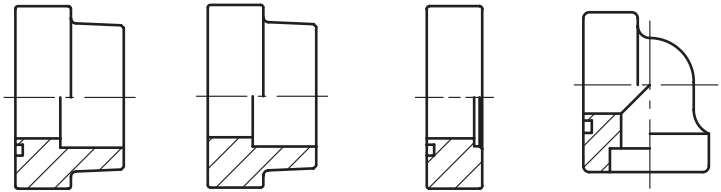
O-Lok® ORFS end

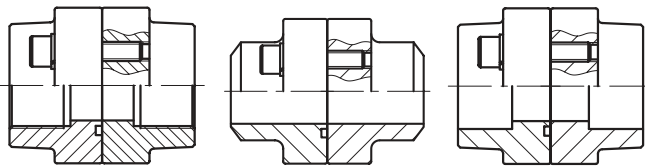
PAFG-L – p. M56 **PAFG-90L** – p. M57

Butt weld end

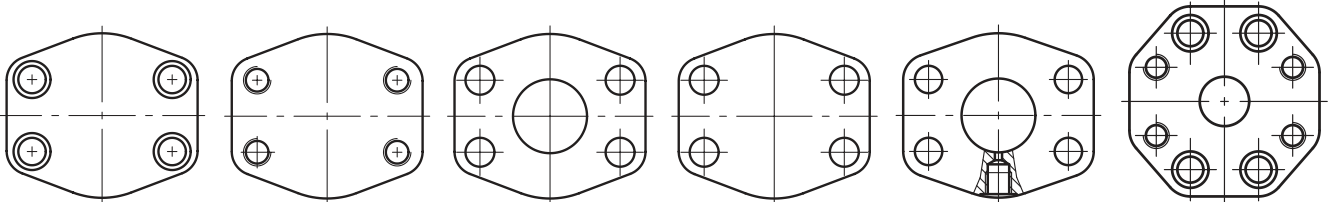
PAFS-B – p. M58 **PGFS-B** – p. M59 **PAFS-90B** – p. M60

Socket weld end

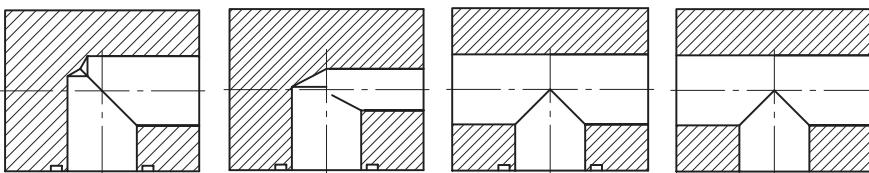
PAFS-S – p. M61 **PGFS-S** – p. M62 **PAFSF-S** – p. M63 **PAFS-90S** – p. M64

Complete flange connections

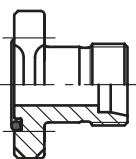
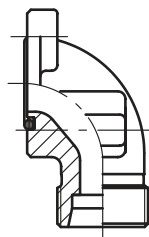
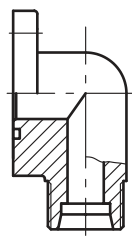
PDFS-G – p. M65 **PDFS-B** – p. M66 **PDFS-S** – p. M67

SAE Flange accessories

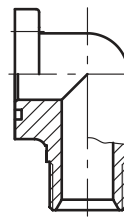
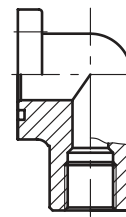
PCFF – p. M68 **PCCFF** – p. M69 **CPM** – p. M70 **AP** – p. M71 **PAGL-(G/M)** – p. M72 **PRF** – p. M73

SAE Junction blocks

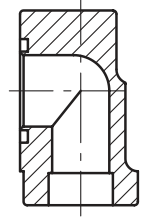
PBL – p. M74 **PBLR** – p. M75 **PBT** – p. M76 **PBTC** – p. M77

Gear pump flanges
EO 24° cone end

BFG – p. M78

BFW – p. M79

BFW-3 – p. M80

Male/Female BSPP thread

BFW-G – p. M81

BFW-GI – p. M82

Socket weld end

BFW-S – p. M83

Visual index

Gear pump flanges

Special pump size flanges



PF – p. M84

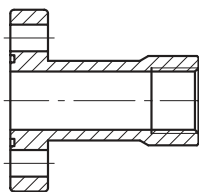

PFL – p. M84

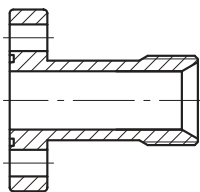

PFE – p. M85

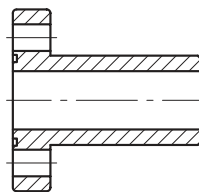

PFB – p. M85

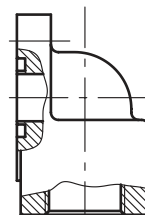

BFW3-G – p. M86

Aluminium flanges

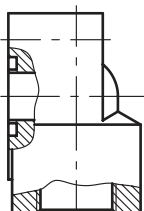

PWDS-G – p. M87

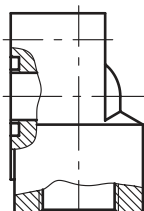

PWDA – p. M88

ISO 6164 Square flanges



PSFC – p. M89

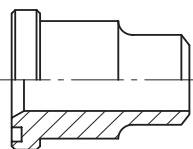

PSFA-B – p. M90

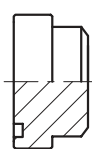

PSFP – p. M91

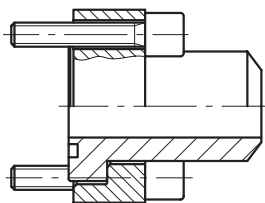

PSF-B – p. M92

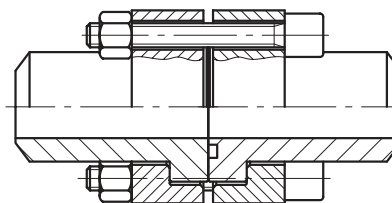

PDSF-B – p. M93

Cetop square flanges

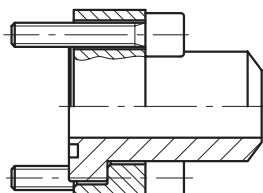

PCF-B – p. M94

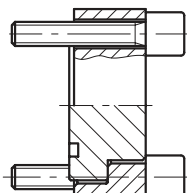

PPCF – p. M95

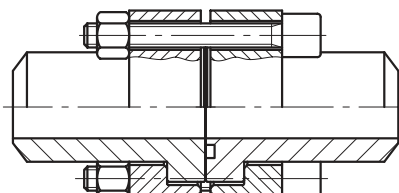

PDCF-B – p. M96

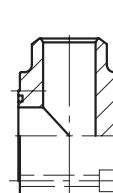

PLCF-B – p. M97

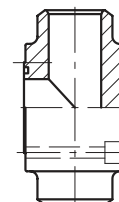

PTCF-B – p. M98

Ball valve flanges

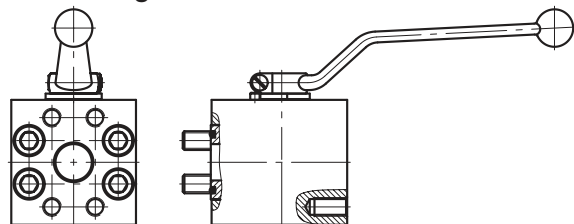

KH-B1V-S – p. M99

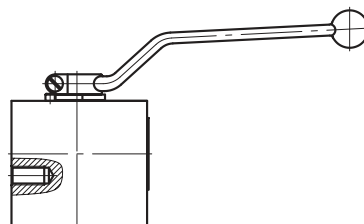

KH-B2V-S – p. M100

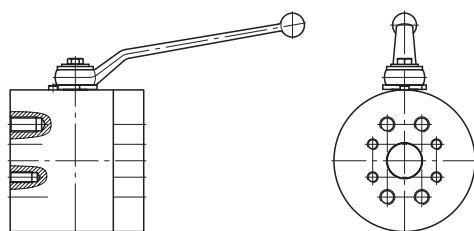

KH-B3V-S – p. M101

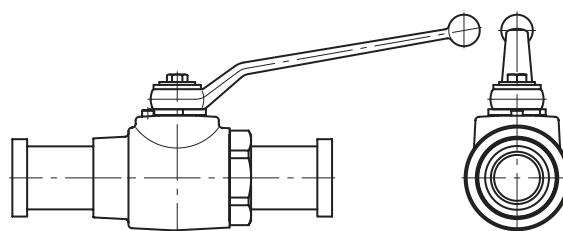

KH-A-S – p. M102

FHS SAE Split flange halves

ISO 6162-1/-2

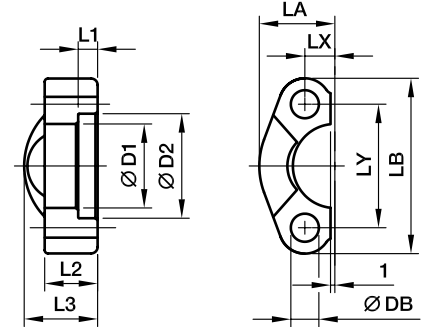

3000 PSI Series

Nom. flange size												Screws		Weight (steel) kg/piece	Order code*	PN (bar) ¹⁾	
SAE (in)	ISO (DN)	D1	D2	L1	L2	L3	LA	LB	LX	LY	DB	(metr.)	(unc.)			A3C	SS
1/2	13	24.3	31.0	6.2	13	20	23.0	54	8.7	38.1	8.8	M 8 25	5/16 1 1/4	0.07	FHS32	345	345
3/4	19	32.1	38.9	6.2	14	22	26.0	65	11.1	47.6	10.5	M10 30	3/8 1 1/4	0.09	FHS33	345	345
1	25	38.5	45.2	7.5	16	22	29.2	70	13.1	52.4	10.5	M10 30	3/8 1 1/4	0.11	FHS34	345	345
1 1/4	32	43.7	51.6	7.5	14	22	36.3	80	15.1	58.7	10.5	M10 35	-	0.15	FHS35/10	276	276
1 1/4	32	43.7	51.6	7.5	14	22	36.3	80	15.1	58.7	12.0	-	7/16 1 1/2	0.15	FHS35/12	276	276
1 1/4	32	43.7	51.6	7.5	14	22	36.3	80	15.1	58.7	12.5	M12 35	-	0.15	FHS35	276	276
1 1/2	38	50.8	61.1	7.5	16	24	41.1	94	17.9	69.9	13.5	M12 35	1/2 1 1/2	0.23	FHS36	207	207
1 1/2	38	50.8	61.1	7.5	16	24	41.1	94	17.9	69.9	14.5	M14 35	-	0.23	FHS36/14	207	207
2	51	62.7	72.2	9.0	16	26	48.2	102	21.4	77.8	13.5	M12 35	1/2 1 1/2	0.25	FHS38/12	207	207
2	51	62.7	72.2	9.0	16	26	48.2	102	21.4	77.8	14.5	M14 35	-	0.25	FHS38	207	207
2 1/2	64	74.9	84.9	9.0	19	38	54.0	115	25.4	88.9	13.5	M12 40	1/2 1 1/2	0.37	FHS310	172	172
2 1/2	64	74.9	84.9	9.0	19	38	54.0	115	25.4	88.9	14.5	M14 40	-	0.37	FHS310/14	172	172
3	76	90.9	102.4	9.0	22	40	65.3	135	31.0	106.4	17.0	M16 45	5/8 2	0.65	FHS312	138	138
3 1/2	89	102.4	115.0	10.7	22	45	70.0	152	34.9	120.7	17.0	M16 45	5/8 2	0.75	FHS314	34	34
4	102	115.1	127.8	10.7	25	48	75.0	160	38.9	130.2	17.0	M16 50	5/8 2	0.84	FHS316	34	34
5	127	140.5	153.2	10.7	28	50	82.0	183	46.0	152.4	17.0	M16 50	5/8 2	1.25	FHS320	34	34

6000 PSI Series

1/2	13	24.6	32.5	7.2	16	22	24.0	57	9.1	40.5	8.8	M 8 30	5/16 1 1/4	0.08	FHS62	420	420
3/4	19	32.5	42.0	8.3	19	28	30.0	72	11.9	50.8	10.5	M10 35	3/8 1 1/4	0.18	FHS63	420	420
1	25	38.9	48.4	9.0	24	32	35.0	81	13.9	57.2	13.0	M12 45	-	0.27	FHS64	420	420
1	25	38.9	48.4	9.0	24	32	35.0	81	13.9	57.2	12.0	-	7/16 1 1/2	0.27	FHS64/12	420	420
1 1/4	32	44.5	54.8	9.8	27	38	39.0	96	15.9	66.6	15.0	M14 50	-	0.27	FHS65	420	420
1 1/4	32	44.5	54.8	9.8	27	38	39.0	96	15.9	66.6	13.5	M12 45	1/2 1 3/4	0.27	FHS65/12	420	420
1 1/2	38	51.6	64.3	12.1	30	42	48.0	113	18.3	79.3	17.0	M16 55	5/8 2	0.40	FHS66	420	420
2	51	67.6	80.2	12.1	37	52	57.0	134	22.2	96.8	21.0	M20 65	3/4 2 1/2	0.40	FHS68	420	420
2 1/2	64	89.5	108.5	20.0	48	48	75.0	175	29.4	123.8	25.0	M24 75	-	0.68	FHS610	420	420
3	76	114.5	132.5	25.0	58	58	89.0	210	35.7	152.4	32.0	M30 90	-	1.05	FHS612	420	420

¹⁾ Pressure shown = Item deliverable

$$\frac{PN (\text{bar})}{10} = PN (\text{MPa})$$

*Please add the suffixes below according to the material / surface required.

Order code suffixes			
Material	Suffix surface and material	Example	Description
Steel, zinc plated, chrome ⁶ -free	CF	FHS32CF	only flange halve
Steel, zinc yellow plated	A3C	FHS32A3CX	only flange halve
Stainless steel	SS	FHS32SS	only flange halve

FUS SAE Flange clamps

ISO 6162-1/-2

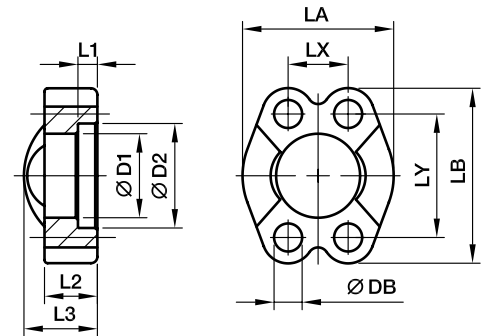

3000 PSI Series

Nom. flange size		D1	D2	L1	L2	L3	LA	LB	LX	LY	DB	Screws		Weight (steel) kg/piece	Order code*	PN (bar) ¹⁾	
SAE (in)	ISO (DN)											(metr.)	(unc.)			A3C	SS
1/2	13	24.3	31.0	6.2	13	20	46	54	17.5	38.1	8.8	M 8 25	5/16 1 1/4	0.15	FUS32	345	345
3/4	19	32.1	38.9	6.2	14	22	52	65	22.3	47.6	10.5	M10 30	3/8 1 1/4	0.17	FUS33	345	345
1	25	38.5	45.2	7.5	16	22	59	70	26.2	52.4	10.5	M10 30	3/8 1 1/4	0.22	FUS34	345	345
1 1/4	32	43.7	51.6	7.5	14	22	73	80	30.2	58.7	10.5	M10 35	-	0.30	FUS35/10	276	276
1 1/4	32	43.7	51.6	7.5	14	22	73	80	30.2	58.7	12.0	-	7/16 1 1/2	0.29	FUS35/12	276	276
1 1/4	32	43.7	51.6	7.5	14	22	73	80	30.2	58.7	12.5	M12 35	-	0.29	FUS35	276	276
1 1/2	38	50.8	61.1	7.5	16	24	83	94	35.8	69.9	13.5	M12 35	1/2 1 1/2	0.45	FUS36	207	207
1 1/2	38	50.8	61.1	7.5	16	24	83	94	35.8	69.9	14.5	M14 35	-	0.44	FUS36/14	207	207
2	51	62.7	72.2	9.0	16	26	97	102	42.8	77.8	13.5	M12 35	1/2 1 1/2	0.50	FUS38/12	207	207
2	51	62.7	72.2	9.0	16	26	97	102	42.8	77.8	14.5	M14 35	-	0.49	FUS38	207	207
2 1/2	64	74.9	84.9	9.0	19	38	109	115	50.8	88.9	13.5	M12 40	1/2 1 1/2	0.74	FUS310	172	172
2 1/2	64	74.9	84.9	9.0	19	38	109	115	50.8	88.9	14.5	M14 40	-	0.73	FUS310/14	172	172
3	76	90.9	102.4	9.0	22	40	131	135	61.9	106.4	17.0	M16 45	5/8 2	1.30	FUS312	138	138
3 1/2	89	102.4	115.0	10.7	22	45	140	152	69.9	120.7	17.0	M16 45	5/8 2	1.50	FUS314	34	34
4	102	115.1	127.8	10.7	25	48	150	160	77.8	130.2	17.0	M16 50	5/8 2	1.65	FUS316	34	34
5	127	140.5	153.2	10.7	28	50	180	183	92.1	152.4	17.0	M16 50	5/8 2	2.50	FUS320	34	34

6000 PSI Series

1/2	13	24.6	32.5	7.2	16	22	48	57	18.2	40.5	8.8	M 8 30	5/16 1 1/4	0.16	FUS62	420	420
3/4	19	32.5	42.0	8.3	19	28	60	72	23.8	50.8	10.5	M10 35	3/8 1 1/4	0.35	FUS63	420	420
1	25	38.9	48.4	9.0	24	32	70	81	27.8	57.2	13.0	M12 45	-	0.53	FUS64	420	420
1	25	38.9	48.4	9.0	24	32	70	81	27.8	57.2	12.0	-	7/16 1 1/2	0.53	FUS64/12	420	420
1 1/4	32	44.5	54.8	9.8	27	38	78	96	31.8	66.6	15.0	M14 50	-	0.80	FUS65	420	420
1 1/4	32	44.5	54.8	9.8	27	38	78	96	31.8	66.6	13.5	M12 45	1/2 1 3/4	0.80	FUS65/12	420	420
1 1/2	38	51.6	64.3	12.1	30	42	96	113	36.5	79.3	17.0	M16 55	5/8 2	1.35	FUS66	420	420
2	51	67.6	80.2	12.1	37	52	114	134	44.5	96.8	21.0	M20 65	3/4 2 1/2	2.10	FUS68	420	420
2 1/2	64	89.5	108.5	20.0	48	48	150	175	58.7	123.8	25.0	M24 75	-	4.10	FUS610	420	420
3	76	114.5	132.5	25.0	58	58	178	210	71.4	152.4	32.0	M30 90	-	8.60	FUS612	420	420

¹⁾ Pressure shown = Item deliverable

$\frac{PN(\text{bar})}{10} = PN(\text{MPa})$

*Please add the suffixes below according to the material / surface required.

Order code suffixes			
Material	Suffix surface and material	Example	Description
Steel, zinc plated, chrome ⁶ -free	CF	FUS32CF	only flange clamp
Steel, zinc yellow plated	A3C	FUS32A3CX	only flange clamp
Stainless steel	SS	FUS32SS	only flange clamp

FUSM SAE Flange clamps with metric tapped holes

ISO 6162-1/-2

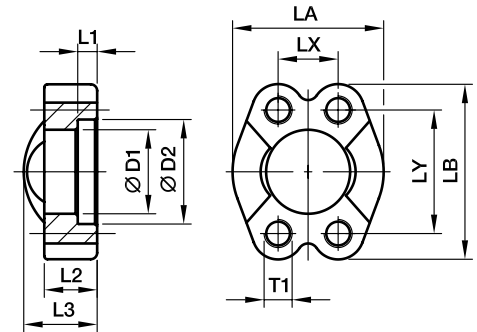

3000 PSI Series

Nom. flange size		D1	D2	L1	L2	L3	LA	LB	LX	LY	T1	Weight (steel) kg/piece	Order code*	PN (bar) ¹⁾	
SAE (in)	ISO (DN)													A3C	SS
1/2	13	24.3	31.0	6.2	13	20	46	54	17.5	38.1	M 8	0.15	FUSM32	345	345
3/4	19	32.1	38.9	6.2	14	22	52	65	22.3	47.6	M10	0.17	FUSM33	345	345
1	25	38.5	45.2	7.5	16	22	59	70	26.2	52.4	M10	0.22	FUSM34	345	345
1 1/4	32	43.7	51.6	7.5	14	22	73	80	30.2	58.7	M10	0.30	FUSM35/10	276	276
1 1/4	32	43.7	51.6	7.5	14	22	73	80	30.2	58.7	M12	0.29	FUSM35/12	276	276
1 1/2	38	50.8	61.1	7.5	16	24	83	94	35.8	69.9	M12	0.45	FUSM36	207	207
1 1/2	38	50.8	61.1	7.5	16	24	83	94	35.8	69.9	M14	0.44	FUSM36/14	207	207
2	51	62.7	72.2	9.0	16	26	97	102	42.8	77.8	M12	0.50	FUSM38/12	207	207
2	51	62.7	72.2	9.0	16	26	97	102	42.8	77.8	M14	0.49	FUSM38	207	207
2 1/2	64	74.9	84.9	9.0	19	38	109	115	50.8	88.9	M12	0.74	FUSM310	172	172
2 1/2	64	74.9	84.9	9.0	19	38	109	115	50.8	88.9	M14	0.73	FUSM310/14	172	172
3	76	90.9	102.4	9.0	22	40	131	135	61.9	106.4	M16	1.30	FUSM312	138	138
3 1/2	89	102.4	115.0	10.7	23	45	140	152	69.9	120.7	M16	1.50	FUSM314	34	34
4	102	115.1	127.8	10.7	25	48	150	160	77.8	130.2	M16	1.65	FUSM316	34	34
5	127	140.5	153.2	10.7	28	50	180	183	92.1	152.4	M16	2.50	FUSM320	34	34

6000 PSI Series

1/2	13	24.6	32.5	7.2	16	22	48	57	18.2	40.5	M 8	0.16	FUSM62	420	420
3/4	19	32.5	42.0	8.3	19	28	60	72	23.8	50.8	M10	0.35	FUSM63	420	420
1	25	38.9	48.4	9.0	24	32	70	81	27.8	57.2	M12	0.53	FUSM64	420	420
1 1/4	32	44.5	54.8	9.8	27	38	78	96	31.8	66.6	M14	0.80	FUSM65	420	420
1 1/2	38	51.6	64.3	12.1	30	42	96	113	36.5	79.3	M16	1.35	FUSM66	420	420
2	51	67.6	80.2	12.1	37	52	114	134	44.5	96.8	M20	2.10	FUSM68	420	420
2 1/2	64	89.5	108.5	20.0	48	48	150	175	58.7	123.8	M24	4.10	FUSM610	420	420
3	76	114.5	132.5	25.0	58	58	178	210	71.4	152.4	M30	8.60	FUSM612	420	420

¹⁾ Pressure shown = Item deliverable

$\frac{PN \text{ (bar)}}{10} = PN \text{ (MPa)}$

*Please add the suffixes below according to the material / surface required.

Order code suffixes			
Material	Suffix surface and material	Example only flange clamp with metr. threads	Description
Steel, zinc plated, chrome ⁶ -free	CF	FUSM32CFM	only flange clamp
Steel, zinc yellow plated	A3C	FUSM32A3CM	only flange clamp
Stainless steel	SS	FUSM32SSM	only flange clamp



FHSF SAE Flange halves flat

ISO 6162-1/-2

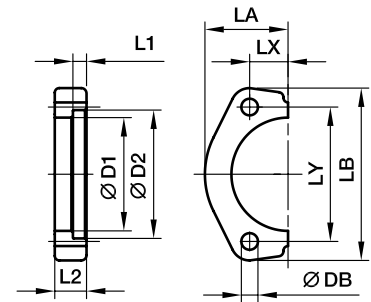
3000 PSI Series

Nom. flange size		D1	D2	L1	L2	LA	LB	LX	LY	DB	Screws		Weight (steel) kg/piece	Order code*	PN (bar) ¹⁾	
SAE (in)	ISO (DN)										(metr.)	(unc.)			A3C	SS
1/2	13	24.3	31.0	6.2	13	24	56	8.7	38.1	8.8	M 8 25	5/16 1 1/4	0.06	FHSF32	345	345
3/4	19	32.1	38.9	6.2	14	27	66	11.1	47.6	10.5	M10 30	3/8 1 1/4	0.07	FHSF33	345	345
1	25	38.5	45.2	7.5	16	30	70	13.1	52.4	10.5	M10 30	3/8 1 1/4	0.10	FHSF34	345	345
1 1/4	32	43.7	51.6	7.5	16	35	79	15.1	58.7	10.5	M10 35	7/16 1 1/2	0.15	FHSF35/10	276	276
1 1/4	32	43.7	51.6	7.5	16	35	79	15.1	58.7	12.5	M12 35	-	0.14	FHSF35/12	276	276
1 1/2	38	50.8	61.1	7.5	16	39	94	17.9	69.9	13.5	M12 35	1/2 1 1/2	0.18	FHSF36	207	207
1 1/2	38	50.8	61.1	7.5	16	39	94	17.9	69.9	14.5	M14 35	-	0.17	FHSF36/14	207	207
2	51	62.7	72.2	9.0	16	49	104	21.4	77.8	13.5	M12 35	1/2 1 1/2	0.22	FHSF38	207	207
2	51	62.7	72.2	9.0	16	49	104	21.4	77.8	14.5	M14 35	-	0.21	FHSF38/14	207	207
2 1/2	64	74.9	84.9	9.0	20	55	114	25.4	88.9	13.5	M12 40	1/2 1 1/2	0.58	FHSF310	172	172
2 1/2	64	74.9	84.9	9.0	20	55	114	25.4	88.9	14.5	M14 40	-	0.57	FHSF310/14	172	172
3	76	90.9	102.4	9.0	22	66	135	31.0	106.4	17.0	M16 45	5/8 2	0.98	FHSF312	138	138

6000 PSI Series

1/2	13	24.6	32.5	7.2	18	24	56	9.1	40.5	8.8	M 8 30	5/16 1 1/4	0.08	FHSF62	420	420
3/4	19	32.5	42.0	8.3	21	30	70	11.9	50.8	10.5	M10 35	3/8 1 1/4	0.16	FHSF63	420	420
1	25	38.9	48.4	9.0	26	35	79	13.9	57.2	13.0	M12 45	7/16 1 1/2	0.25	FHSF64	420	420
1 1/4	32	44.5	54.8	9.8	29	39	94	15.9	66.6	15.0	M14 50	1/2 1 3/4	0.34	FHSF65	420	420
1 1/2	38	51.6	64.3	12.1	33	49	109	18.3	79.3	17.0	M16 55	5/8 2	0.55	FHSF66	420	420
2	51	67.6	80.2	12.1	42	57	133	22.2	96.8	21.0	M20 65	3/4 2 1/2	1.02	FHSF68	420	420

1) Pressure shown = Item deliverable

$$\frac{PN \text{ (bar)}}{10} = PN \text{ (MPa)}$$

Material for steel: C60

*Please add the suffixes below according to the material / surface required.

Order code suffixes			
Material	Suffix surface and material	Example	Description
Steel, zinc plated, chrome ⁶ -free	CF	FHSF32CF	only flange halve
Steel, zinc yellow plated	A3C	FHSF32A3C	only flange halve
Stainless steel	SS	FHSF32SS	only flange halve

FUSF SAE Flange clamps flat

ISO 6162-1/-2

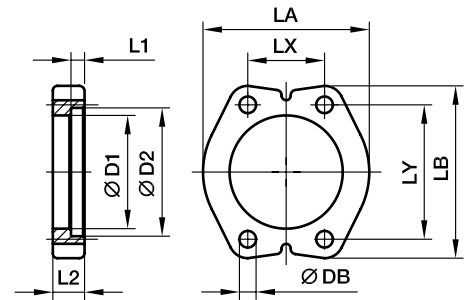
3000 PSI Series

Nom. flange size		D1	D2	L1	L2	LA	LB	LX	LY	DB	Screws		Weight (steel) kg/piece	Order code*	PN (bar) ¹⁾	
SAE (in)	ISO (DN)										(metr.)	(unc.)			A3C	SS
1/2	13	24.3	31.0	6.2	13	48	56	17.4	38.1	8.8	M 8 25	5/16 1 1/4	0.13	FUSF32	345	345
3/4	19	32.1	38.9	6.2	14	54	66	22.2	47.6	10.5	M10 30	3/8 1 1/4	0.15	FUSF33	345	345
1	25	38.5	45.2	7.5	16	60	70	26.2	52.4	10.5	M10 30	3/8 1 1/4	0.21	FUSF34	345	345
1 1/4	32	43.7	51.6	7.5	16	70	79	30.2	58.7	10.5	M10 35	7/16 1 1/2	0.31	FUSF35/10	276	276
1 1/4	32	43.7	51.6	7.5	16	70	79	30.2	58.7	12.5	M12 35	-	0.28	FUSF35/12	276	276
1 1/2	38	50.8	61.1	7.5	16	78	94	35.8	69.9	13.5	M12 35	1/2 1 1/2	0.35	FUSF36	207	207
1 1/2	38	50.8	61.1	7.5	16	78	94	35.8	69.9	14.5	M14 35	-	0.33	FUSF36/14	207	207
2	51	62.7	72.2	9.0	16	98	104	42.8	77.8	13.5	M12 35	1/2 1 1/2	0.43	FUSF38/12	207	207
2	51	62.7	72.2	9.0	16	98	104	42.8	77.8	14.5	M14 35	-	0.41	FUSF38	207	207
2 1/2	64	74.9	84.9	9.0	20	110	114	50.8	88.9	13.5	M12 40	1/2 1 1/2	1.15	FUSF310	172	172
2 1/2	64	74.9	84.9	9.0	20	110	114	50.8	88.9	14.5	M14 40	-	1.43	FUSF310/14	172	172
3	76	90.9	102.4	9.0	22	132	135	61.9	106.4	17.0	M16 45	5/8 2	1.95	FUSF312	138	138

6000 PSI Series

1/2	13	24.6	32.5	7.2	18	48	56	18.2	40.5	8.8	M 8 30	5/16 1 1/4	0.15	FUSF62	420	420
3/4	19	32.5	42.0	8.3	21	60	70	23.8	50.8	10.5	M10 35	3/8 1 1/4	0.31	FUSF63	420	420
1	25	38.9	48.4	9.0	26	70	79	27.8	57.2	13.0	M12 45	7/16 1 1/2	0.49	FUSF64	420	420
1 1/4	32	44.5	54.8	9.8	29	78	94	31.8	66.6	15.0	M14 50	1/2 1 3/4	0.67	FUSF65	420	420
1 1/2	38	51.6	64.3	12.1	33	98	109	36.5	79.3	17.0	M16 55	5/8 2	1.08	FUSF66	420	420
2	51	67.6	80.2	12.1	42	114	133	44.5	96.8	21.0	M20 65	3/4 2 1/2	2.03	FUSF68	420	420

1) Pressure shown = Item deliverable

$$\frac{PN \text{ (bar)}}{10} = PN \text{ (MPa)}$$

Material for steel: C60

*Please add the suffixes below according to the material / surface required.

Order code suffixes			
Material	Suffix surface and material	Example	Description
Steel, zinc plated, chrome ⁶ -free	CF	FUSF32CF	only flange clamp
Steel, zinc yellow plated	A3C	FUSF32A3C	only flange clamp
Stainless steel	SS	FUSF32SS	only flange clamp

GFS SAE Straight flange adapter

SAE Flange / EO 24° cone end
(ISO 6162-1/-2)

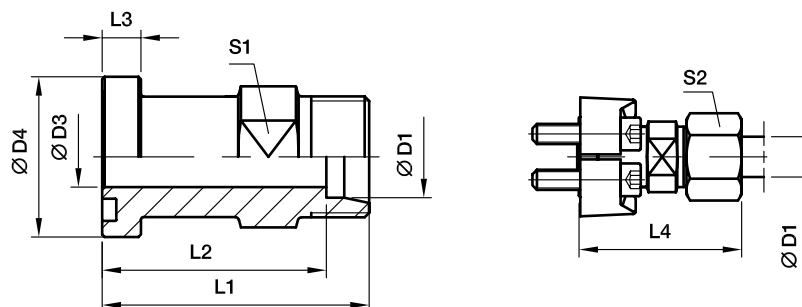

3000 PSI Series

Nom. flange size		D1 ²⁾	D3	D4	L1	L2	L3	L4	S1	S2	Screws		Weight (steel) kg/piece	Order code*	PN (bar) ¹⁾	
SAE (in)	ISO (DN)										(metr.)	(unc.)			A3C	71
1/2	13	15L	12	30.2	48.0	41.0	6.7	56	24	27	M 8x25	5/16x1 1/4	0.36	GFS32/15L	315	315
1/2	13	16S	12	30.2	50.0	41.5	6.7	60	24	30	M 8x25	5/16x1 1/4	0.40	GFS32/16S	350	350
1/2	13	18L	12	30.2	50.0	42.5	6.7	61	19	32	M 8x25	5/16x1 1/4	0.42	GFS32/18L	315	315
3/4	19	16S	19	38.1	55.0	46.5	6.7	65	27	30	M10x30	3/8x1 1/4	0.52	GFS33/16S	350	350
3/4	19	18L	19	38.1	53.0	45.5	6.7	62	30	32	M10x30	3/8x1 1/4	0.59	GFS33/18L	315	315
3/4	19	22L	19	38.1	53.0	45.5	6.7	62	30	36	M10x30	3/8x1 1/4	0.59	GFS33/22L	160	160
3/4	19	28L	19	38.1	53.0	45.5	6.7	62	30	41	M10x30	3/8x1 1/4	0.60	GFS33/28L	160	160
3/4	19	20S	19	38.1	57.0	46.5	6.7	68	30	36	M10x30	3/8x1 1/4	0.65	GFS33/20S	350	350
3/4	19	25S	19	38.1	57.0	45.0	6.7	69	30	46	M10x30	3/8x1 1/4	0.78	GFS33/25S	350	350
1	25	20S	25	44.5	60.0	48.5	8.0	71	32	36	M10x30	3/8x1 1/4	0.70	GFS34/20S	350	350
1	25	28L	25	44.5	54.0	46.5	8.0	63	36	41	M10x30	3/8x1 1/4	0.73	GFS34/28L	160	160
1	25	25S	25	44.5	58.0	46.5	8.0	60	36	46	M10x30	3/8x1 1/4	0.84	GFS34/25S	350	350
1	25	30S	25	44.5	63.0	49.5	8.0	76	36	50	M10x30	3/8x1 1/4	0.94	GFS34/30S	250	250
1 1/4	32	35L	29	50.8	58.0	47.5	8.0	69	41	50	M10x35	-	0.96	GFS35/35L/10 ³⁾	160	160
1 1/4	32	25S	29	50.8	60.0	48.0	8.0	72	41	46	M10x35	-	1.11	GFS35/25S/10	200	200
1 1/4	32	30S	29	50.8	62.0	48.5	8.0	75	41	50	M10x35	-	1.13	GFS35/30S/10	200	200
1 1/4	32	38S	29	50.8	66.0	50.0	8.0	81	46	60	M10x35	-	1.36	GFS35/38S/10	200	200
1 1/4	32	28L	29	50.8	58.0	50.5	8.0	67	36	41	M12x40	7/16x1 1/2	1.12	GFS35/28L	160	160
1 1/4	32	35L	29	50.8	58.0	47.5	8.0	69	41	50	M12x40	7/16x1 1/2	1.02	GFS35/35L	160	160
1 1/4	32	25S	29	50.8	60.0	48.0	8.0	72	41	46	M12x40	7/16x1 1/2	1.17	GFS35/25S	200	200
1 1/4	32	30S	29	50.8	62.0	48.5	8.0	75	41	50	M12x40	7/16x1 1/2	1.20	GFS35/30S	200	200
1 1/4	32	38S	29	50.8	66.0	50.0	8.0	81	46	60	M12x40	7/16x1 1/2	1.41	GFS35/38S	200	200
1 1/2	38	35L	36	60.3	65.0	54.5	8.0	76	46	50	M12x35	1/2x1 1/2	1.20	GFS36/35L	160	160
1 1/2	38	42L	36	60.3	64.0	53.0	8.0	76	46	60	M12x35	1/2x1 1/2	1.36	GFS36/42L	160	160
1 1/2	38	38S	36	60.3	70.0	54.0	8.0	85	46	60	M12x35	1/2x1 1/2	1.63	GFS36/38S	200	200

1) Pressure shown = Item deliverable

2) L = light series; S = heavy series

$\frac{PN \text{ (bar)}}{10} = PN \text{ (MPa)}$

Delivery without nut and ring.

Information on ordering complete fittings

or alternative sealing materials see page M11.

3) Order code for the flange adapter assembled with FHS35/10A3CX and M10X35 screws.

*Please add the suffixes below according to the material / surface required.

Order code suffixes					
Material	Suffix surface and material	Example only flange adapter	Example incl. splitflanges, metr. screws and O-ring	Example incl. splitflanges, UNC screws and O-ring	Standard sealing material (no additional suffix needed)
Steel, zinc plated, chrome ⁶ -free	CF	GFS32/16SCFX	GFS32/16SOMDCF	GFS32/16SOMDCFU	NBR
Steel, zinc yellow plated	A3C	GFS32/16SA3CX	GFS32/16SOMDA3C	GFS32/16SOMDA3CU	NBR
Stainless steel	71	GFS32/16S71X	GFS32/16SOMD71	GFS32/16SOMD71U	VIT

GFS SAE Straight flange adapter

SAE Flange / EO 24° cone end
(ISO 6162-1/-2)

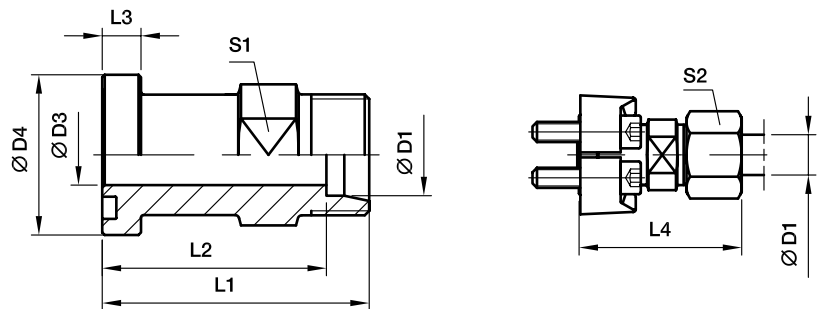

6000 PSI Series

Nom. flange size		D1 ²⁾											Screws		Weight (steel) kg/piece	PN (bar) ¹⁾	
SAE (in)	ISO (DN)		D3	D4	L1	L2	L3	L4	S1	S2	(metr.)	(unc.)	Order code*	A3C		71	
1/2	13	12S	12	31.8	43.0	50.0	7.7	57	19	24	M 8x30	5/16x1 1/4	0.35	GFS62/12S	420	420	
1/2	13	14S	12	31.8	43.5	50.0	7.7	59	19	27	M 8x30	5/16x1 1/4	0.39	GFS62/14S	420	420	
1/2	13	16S	12	31.8	44.5	53.0	7.7	63	24	30	M 8x30	5/16x1 1/4	0.47	GFS62/16S	420	420	
3/4	19	16S	17	41.3	50.5	59.0	8.7	69	30	30	M10x35	3/8x1 1/4	0.79	GFS63/16S	420	420	
3/4	19	20S	17	41.3	50.5	61.0	8.7	72	30	36	M10x35	3/8x1 1/4	0.86	GFS63/20S	420	400	
3/4	19	25S	17	41.3	51.0	63.0	8.7	75	30	46	M10x35	3/8x1 1/4	0.97	GFS63/25S	420	400	
3/4	19	30S	17	41.3	62.0	76.0	8.7	90	30	50	M10x35	3/8x1 1/4	1.15	GFS63/30S	420	400	
1	25	20S	24	47.6	63.0	75.0	9.5	88	36	36	M12x45	7/16x1 1/2	0.97	GFS64/20S	420	400	
1	25	25S	24	47.6	60.0	72.0	9.5	84	36	46	M12x45	7/16x1 1/2	1.42	GFS64/25S	420	400	
1	25	30S	24	47.6	62.0	74.0	9.5	87	36	50	M12x45	7/16x1 1/2	1.40	GFS64/30S	420	400	
1 1/4	32	25S	30	54.0	68.0	80.0	10.2	90	41	46	M14x50	1/2x1 3/4	1.85	GFS65/25S	420	400	
1 1/4	32	30S	30	54.0	65.5	79.0	10.2	92	41	50	M12x45	-	1.95	GFS65/30S/12³⁾	420	400	
1 1/4	32	38S	30	54.0	67.0	83.0	10.2	98	46	60	M12x45	-	2.16	GFS65/38S/12	315	315	
1 1/4	32	30S	30	54.0	65.5	79.0	10.2	92	41	50	M14x50	1/2x1 3/4	1.90	GFS65/30S	420	400	
1 1/4	32	38S	30	54.0	67.0	83.0	10.2	98	46	60	M14x50	1/2x1 3/4	2.10	GFS65/38S	315	315	
1 1/2	38	30S	30	63.5	74.0	90.0	12.5	98	46	50	M16x55	5/8x2	2.10	GFS66/30S	420	400	
1 1/2	38	38S	30	63.5	73.0	89.0	12.5	104	46	60	M16x55	5/8x2	3.06	GFS66/38S	315	315	

¹⁾ Pressure shown = Item deliverable

²⁾ S = heavy series

$$\frac{PN \text{ (bar)}}{10} = PN \text{ (MPa)}$$

Delivery without nut and ring.

Information on ordering complete fittings or alternative sealing materials see page M11.

³⁾ Order code for the flange adapter assembled with FHS65/12A3CX and M12X45 screws.

*Please add the suffixes below according to the material / surface required.

Order code suffixes					
Material	Suffix surface and material	Example only flange adapter	Example incl. splitflanges, metr. screws and O-ring	Example incl. splitflanges, UNC screws and O-ring	Standard sealing material (no additional suffix needed)
Steel, zinc plated, chrome ⁶ -free	CF	GFS62/16SCFX	GFS62/16SOMDCF	GFS62/16SOMDCFU	NBR
Steel, zinc yellow plated	A3C	GFS62/16SA3CX	GFS62/16SOMDA3C	GFS62/16SOMDA3CU	NBR
Stainless steel	71	GFS62/16S71X	GFS62/16SOMD71	GFS62/16SOMD71U	VIT



WFS SAE 90° Elbow flange adapter

SAE Flange / EO 24° cone end
(ISO 6162-1/-2)

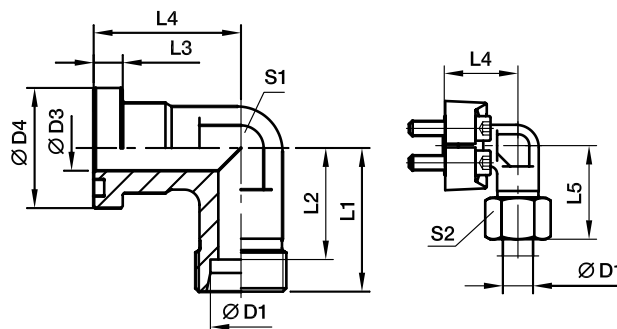

3000 PSI Series

Nom. flange size		D1 ²⁾											Screws		Weight (steel) kg/piece	Order code*	PN (bar) ¹⁾	
SAE (in)	ISO (DN)		D3	D4	L1	L2	L3	L4	L5	S1	S2	(metr.)	(unc.)	A3C			71	
1/2	13	12S	12	30.2	50	42.5	6.7	44	57	22	24	M 8x25	5/16x1 1/4	0.38	WFS32/12S	210	210	
1/2	13	15L	12	30.2	36	29.0	6.7	36	44	24	27	M 8x25	5/16x1 1/4	0.40	WFS32/15L	315	315	
1/2	13	16S	12	30.2	38	29.5	6.7	36	48	24	30	M 8x25	5/16x1 1/4	0.43	WFS32/16S	350	350	
1/2	13	18L	12	30.2	50	42.5	6.7	44	59	22	32	M 8x25	5/16x1 1/4	0.44	WFS32/18L	315	315	
3/4	19	16S	19	38.1	64	55.5	6.7	53	74	27	30	M10x30	3/8x1 1/4	0.60	WFS33/16S	350	350	
3/4	19	18L	19	38.1	39	31.5	6.7	42	48	30	32	M10x30	3/8x1 1/4	0.66	WFS33/18L	315	315	
3/4	19	22L	19	38.1	41	33.5	6.7	42	50	30	36	M10x30	3/8x1 1/4	0.66	WFS33/22L	160	160	
3/4	19	20S	19	38.1	43	32.5	6.7	42	54	30	36	M10x30	3/8x1 1/4	0.76	WFS33/20S	350	350	
3/4	19	25S	19	38.1	45	33.0	6.7	42	57	30	46	M10x30	3/8x1 1/4	0.89	WFS33/25S	350	350	
1	25	20S	25	44.5	65	54.5	8.0	60	76	34	36	M10x30	3/8x1 1/4	0.78	WFS34/20S	350	350	
1	25	22L	25	44.5	65	49.5	8.0	60	74	34	36	M10x30	3/8x1 1/4	0.81	WFS34/22L	160	160	
1	25	28L	25	44.5	44	36.5	8.0	45	53	36	41	M10x30	3/8x1 1/4	0.85	WFS34/28L	160	160	
1	25	25S	25	44.5	48	36.5	8.0	45	57	36	46	M10x30	3/8x1 1/4	0.95	WFS34/25S	350	350	
1	25	30S	25	44.5	50	36.5	8.0	45	63	36	50	M10x30	3/8x1 1/4	1.06	WFS34/30S	250	250	
1 1/4	32	35L	29	50.8	57	46.5	8.0	50	68	41	50	M10x35	3/8x1 1/4	1.15	WFS35/35L/10³⁾	160	160	
1 1/4	32	25S	29	50.8	55	43.0	8.0	60	67	41	46	M10x35	3/8x1 1/4	1.35	WFS35/25S/10	200	200	
1 1/4	32	30S	29	50.8	57	43.5	8.0	50	70	41	50	M10x35	3/8x1 1/4	1.40	WFS35/30S/10	200	200	
1 1/4	32	38S	29	50.8	59	43.0	8.0	50	74	46	60	M10x35	3/8x1 1/4	1.53	WFS35/38S/10	200	200	
1 1/4	32	35L	29	50.8	57	46.5	8.0	50	68	41	50	M12x40	7/16x1 1/2	1.15	WFS35/35L	160	160	
1 1/4	32	25S	29	50.8	55	43.0	8.0	60	67	41	46	M12x40	7/16x1 1/2	1.35	WFS35/25S	200	200	
1 1/4	32	30S	29	50.8	57	43.5	8.0	50	70	41	50	M12x40	7/16x1 1/2	1.40	WFS35/30S	200	200	
1 1/4	32	38S	29	50.8	59	43.0	8.0	50	74	46	60	M12x40	7/16x1 1/2	1.53	WFS35/38S	200	200	
1 1/2	38	35L	36	60.3	78	67.5	8.0	66	83	50	50	M12x35	1/2x1 1/2	1.55	WFS36/35L	160	160	
1 1/2	38	42L	36	60.3	58	47.0	8.0	55	70	46	60	M12x35	1/2x1 1/2	1.60	WFS36/42L	160	160	
1 1/2	38	38S	36	60.3	64	48.0	8.0	55	79	46	60	M12x35	1/2x1 1/2	1.95	WFS36/38S	200	200	

1) Pressure shown = Item deliverable

2) L = light series; S = heavy series

$$\frac{\text{PN (bar)}}{10} = \text{PN (MPa)}$$

Delivery without nut and ring.

Information on ordering complete fittings

or alternative sealing materials see page M11.

3) Order code for the elbow flange adapter assembled with FHS35/10A3CX and M10X35 screws.

*Please add the suffixes below according to the material / surface required.

Order code suffixes					
Material	Suffix surface and material	Example only flange adapter	Example incl. splitflanges, metr. screws and O-ring	Example incl. splitflanges, UNC screws and O-ring	Standard sealing material (no additional suffix needed)
Steel, zinc plated, chrome ⁶ -free	CF	WFS32/16SCFX	WFS32/16SOMDCF	WFS32/16SOMDCFU	NBR
Steel, zinc yellow plated	A3C	WFS32/16SA3CX	WFS32/16SOMDA3C	WFS32/16SOMDA3CU	NBR
Stainless steel	71	WFS32/16S71X	WFS32/16SOMD71	WFS32/16SOMD71U	VIT

WFS SAE 90° Elbow flange adapter

SAE Flange / EO 24° cone end
(ISO 6162-1/-2)

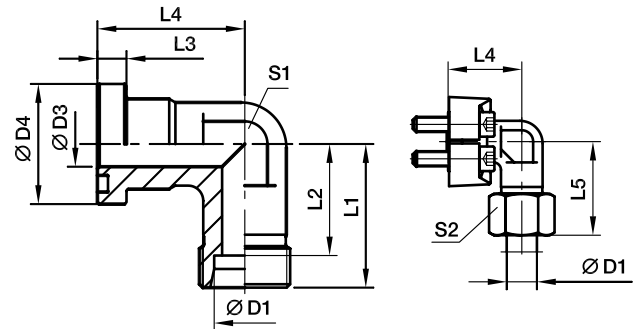

6000 PSI Series

Nom. flange size		D1 ²⁾											Screws		Weight (steel) kg/piece	Order code*	PN (bar) ¹⁾	
SAE (in)	ISO (DN)		D3	D4	L1	L2	L3	L4	L5	S1	S2	(metr.)	(unc.)	A3C			71	
1/2	13	12S	12	31.8	50	43.0	7.7	44	57	22	24	M 8x30	5/16x1 1/4	0.37	WFS62/12S	420	420	
1/2	13	14S	12	31.8	50	43.5	7.7	44	59	22	27	M 8x30	5/16x1 1/4	0.39	WFS62/14S	420	420	
1/2	13	16S	12	31.8	38	29.5	7.7	39	48	24	30	M 8x30	5/16x1 1/4	0.49	WFS62/16S	420	420	
3/4	19	16S	17	41.3	45	36.5	8.7	48	55	32	30	M10x35	3/8x1 1/4	0.92	WFS63/16S	420	420	
3/4	19	20S	17	41.3	46	35.5	8.7	48	57	32	36	M10x35	3/8x1 1/4	0.97	WFS63/20S	420	400	
3/4	19	25S	17	41.3	48	36.0	8.7	48	60	32	46	M10x35	3/8x1 1/4	1.19	WFS63/25S	420	400	
1	25	20S	24	47.6	62	51.5	9.5	60	75	34	36	M12x45	7/16x1 1/2	1.69	WFS64/20S	420	400	
1	25	25S	24	47.6	53	44.0	9.5	60	65	41	46	M12x45	7/16x1 1/2	1.67	WFS64/25S	420	400	
1	25	30S	24	47.6	55	41.5	9.5	60	68	41	50	M12x45	7/16x1 1/2	1.63	WFS64/30S	420	400	
1 1/4	32	25S	30	54.0	72	60.0	10.2	70	84	42	46	M12x45	7/16x1 1/2	2.23	WFS65/25S/12³⁾	420	400	
1 1/4	32	30S	30	54.0	58	44.5	10.2	68	71	46	50	M12x45	7/16x1 1/2	2.20	WFS65/30S/12	420	400	
1 1/4	32	38S	30	54.0	61	45.0	10.2	68	76	46	60	M12x45	7/16x1 1/2	2.39	WFS65/38S/12	315	315	
1 1/4	32	25S	30	54.0	72	60.0	10.2	70	84	42	46	M14x50	1/2x1 3/4	2.23	WFS65/25S	420	400	
1 1/4	32	30S	30	54.0	58	44.5	10.2	68	71	46	50	M14x50	1/2x1 3/4	2.20	WFS65/30S	420	400	
1 1/4	32	38S	30	54.0	61	45.0	10.2	68	76	46	60	M14x50	1/2x1 3/4	2.39	WFS65/38S	315	315	
1 1/2	38	30S	30	63.5	76	63.5	12.5	77	90	50	50	M16x55	5/8x2	2.38	WFS66/30S	420	400	
1 1/2	38	38S	30	63.5	72	56.0	12.5	76	87	50	60	M16x55	5/8x2	2.58	WFS66/38S	315	315	

¹⁾ Pressure shown = Item deliverable

²⁾ S = heavy series

$$\frac{PN \text{ (bar)}}{10} = PN \text{ (MPa)}$$

Delivery without nut and ring.

Information on ordering complete fittings or alternative sealing materials see page M11.

³⁾ Order code for the elbow flange adapter assembled with FHS65/12A3CX and M12X45 screws.

*Please add the suffixes below according to the material / surface required.

Order code suffixes					
Material	Suffix surface and material	Example only flange adapter	Example incl. splitflanges, metr. screws and O-ring	Example incl. splitflanges, UNC screws and O-ring	Standard sealing material (no additional suffix needed)
Steel, zinc plated, chrome ⁶ -free	CF	WFS62/16SCFX	WFS62/16SOMDCF	WFS62/16SOMDCFU	NBR
Steel, zinc yellow plated	A3C	WFS62/16SA3CX	WFS62/16SOMDA3C	WFS62/16SOMDA3CU	NBR
Stainless steel	71	WFS62/16S71X	WFS62/16SOMD71	WFS62/16SOMD71U	VIT



GFS-G SAE Straight flange adapter

SAE Flange / BSPP 60° cone end
(ISO 6162-1/-2) (ISO 8434-6)

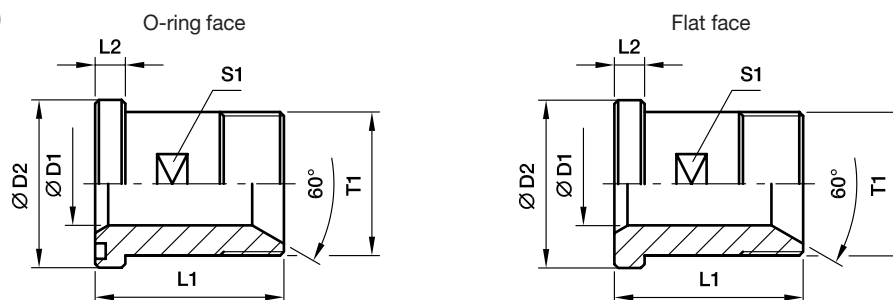

3000 PSI Series

Nom. flange size		T1	D1	D2	L1	L2	S1	Weight (steel) kg/piece	O-ring face Order code*	Flat face Order code*	PN (bar) ¹⁾	
SAE (in)	ISO (DN)										A3C	SS
1/2	13	G1/2	12	30.2	50	6.7	19	0.08	GFS32/12G	GFSG32/12G	345	345
1/2	13	G3/8	10	30.2	50	6.7	19	0.08	GFS32/38G	GFSG32/38G	345	345
3/4	19	G3/4	17	38.1	55	6.7	27	0.16	GFS33/34G	GFSG33/34G	345	345
3/4	19	G1/2	12	38.1	55	6.7	27	0.16	GFS33/12G	GFSG33/12G	345	345
1	25	G1	22	44.4	60	8.0	32	0.23	GFS34/1G	GFSG34/1G	345	345
1	25	G3/4	17	44.4	60	8.0	32	0.23	GFS34/34G	GFSG34/34G	345	345
1 1/4	32	G1 1/4	27	50.8	65	8.0	41	0.30	GFS35/114G	GFSG35/114G	276	276
1 1/4	32	G1	22	50.8	65	8.0	41	0.30	GFS35/1G	GFSG35/1G	276	276
1 1/2	38	G1 1/2	32	60.3	70	8.0	46	0.40	GFS36/112G	GFSG36/112G	207	207
1 1/2	38	G1 1/4	27	60.3	70	8.0	46	0.40	GFS36/114G	GFSG36/114G	207	207
2	51	G2	40	71.4	75	9.5	55	0.50	GFS38/2G	GFSG38/2G	207	207
2	51	G1 1/2	32	71.4	75	9.5	55	0.50	GFS38/112G	GFSG38/112G	207	207

6000 PSI Series

1/2	13	G1/2	12	31.8	50	7.7	19	0.09	GFS62/12G	GFSG62/12G	420	420
1/2	13	G3/8	10	31.8	50	7.7	19	0.09	GFS62/38G	GFSG62/38G	420	420
3/4	19	G3/4	17	41.3	60	8.7	26	0.15	GFS63/34G	GFSG63/34G	420	420
3/4	19	G1/2	12	41.3	60	8.7	26	0.15	GFS63/12G	GFSG63/12G	420	420
1	25	G1	22	47.6	70	9.5	32	0.23	GFS64/1G	GFSG64/1G	420	420
1	25	G3/4	17	47.6	70	9.5	32	0.23	GFS64/34G	GFSG64/34G	420	420
1 1/4	32	G1 1/4	27	54.0	75	10.3	36	0.30	GFS65/114G	GFSG65/114G	420	420
1 1/4	32	G1	22	54.0	75	10.3	36	0.30	GFS65/1G	GFSG65/1G	420	420
1 1/2	38	G1 1/2	32	63.5	80	12.5	46	0.50	GFS66/112G	GFSG66/112G	420	420
1 1/2	38	G1 1/4	27	63.5	80	12.5	46	0.50	GFS66/114G	GFSG66/114G	420	420
2	51	G2	40	79.4	90	12.5	55	0.80	GFS68/2G	GFSG68/2G	420	420
2	51	G1 1/2	32	79.4	90	12.5	55	0.80	GFS68/112G	GFSG68/112G	420	420

¹⁾ Pressure shown = Item deliverable

$$\frac{\text{PN (bar)}}{10} = \text{PN (MPa)}$$

*Please add the suffixes below according to the material / surface required.

Order code suffixes					
Material	Suffix surface and material	Example only flange adapter	Example incl. splitflanges, metr. screws and O-ring	Example incl. splitflanges, UNC screws and O-ring	Standard sealing material (no additional suffix needed)
Steel, zinc plated, chrome ⁶ -free	CF	GFS32/12GCF	GFS32/12GCFM	GFS32/12GCFU	NBR
Steel, zinc yellow plated	A3C	GFS32/12GA3C	GFS32/12GA3CM	GFS32/12GA3CU	NBR
Stainless steel	SS	GFS32/12GSS	GFS32/12GSSM	GFS32/12GSSU	VIT

WFS-G SAE 90° Elbow flange adapter

SAE Flange / BSPP 60° cone end
(ISO 6162-1/-2) (ISO 8434-6)

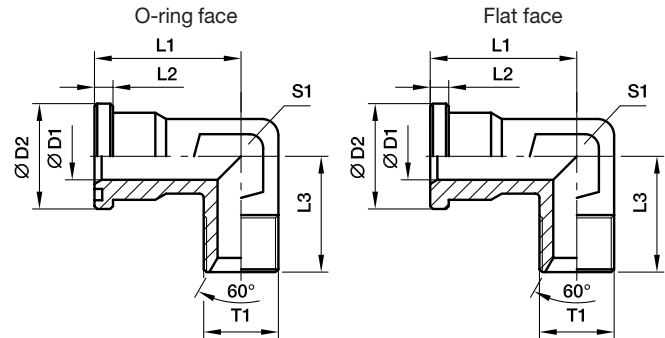

3000 PSI Series

Nom. flange size		T1	D1	D2	L1	L2	L3	S1	Weight (steel) kg/piece	O-ring face Order code*	Flat face Order code*	PN (bar) ¹⁾	
SAE (in)	ISO (DN)											A3C	SS
1/2	13	G1/2	12	30.2	44	6.7	50	22	0.40	WFS32/12G	WFSG32/12G	345	345
1/2	13	G3/8	10	30.2	44	6.7	50	22	0.34	WFS32/38G	WFSG32/38G	345	345
3/4	19	G1/2	12	38.1	53	6.7	64	27	0.60	WFS33/12G	WFSG33/12G	345	345
3/4	19	G3/4	17	38.1	53	6.7	64	27	0.63	WFS33/34G	WFSG33/34G	345	345
3/4	19	G1	19	38.1	53	6.7	64	27	0.66	WFS33/1G	WFSG33/1G	345	345
1	25	G3/4	17	44.4	60	8.0	65	34	0.80	WFS34/34G	WFSG34/34G	345	345
1	25	G1	22	44.4	60	8.0	65	34	0.85	WFS34/1G	WFSG34/1G	345	345
1	25	G1 1/4	25	44.4	60	8.0	65	34	0.89	WFS34/114G	WFSG34/114G	345	345
1 1/4	32	G1	22	50.8	55	8.0	64	42	1.16	WFS35/1G	WFSG35/1G	276	276
1 1/4	32	G1 1/4	28	50.8	55	8.0	64	42	1.27	WFS35/114G	WFSG35/114G	276	276
1 1/2	38	G1 1/4	28	60.3	66	8.0	78	50	1.90	WFS36/114G	WFSG36/114G	207	207
1 1/2	38	G1 1/2	34	60.3	66	8.0	78	50	2.05	WFS36/112G	WFSG36/112G	207	207

6000 PSI Series

1/2	13	G1/2	12	31.8	44	7.7	50	22	0.45	WFS62/12G	WFSG62/12G	420	420
1/2	13	G3/8	10	31.8	44	7.7	50	22	0.37	WFS62/34G	WFSG62/34G	420	420
3/4	19	G1/2	14	41.3	53	8.7	64	27	0.88	WFS63/12G	WFSG63/12G	420	420
3/4	19	G3/4	17	41.3	53	8.7	64	27	0.97	WFS63/34G	WFSG63/34G	420	420
3/4	19	G1	19	41.3	53	8.7	64	27	1.02	WFS63/1G	WFSG63/1G	420	420
1	25	G3/4	17	47.6	60	9.5	62	34	1.46	WFS64/34G	WFSG64/34G	420	420
1	25	G1	22	47.6	60	9.5	62	34	1.57	WFS64/1G	WFSG64/1G	420	420
1	25	G1 1/4	25	47.6	60	9.5	62	34	1.70	WFS64/114G	WFSG64/114G	420	420
1 1/4	32	G1	22	54.0	70	10.3	72	42	2.20	WFS65/1G	WFSG65/1G	420	420
1 1/4	32	G1 1/4	27	54.0	70	10.3	72	42	2.30	WFS65/114G	WFSG65/114G	420	420
1 1/2	38	G1 1/4	27	63.5	80	12.5	84	50	3.08	WFS66/114G	WFSG66/114G	420	420
1 1/2	38	G1 1/2	32	63.5	80	12.5	84	50	3.45	WFS66/112G	WFSG66/112G	420	420

¹⁾ Pressure shown = Item deliverable

$$\frac{PN \text{ (bar)}}{10} = PN \text{ (MPa)}$$

*Please add the suffixes below according to the material / surface required.

Order code suffixes					
Material	Suffix surface and material	Example only flange adapter	Example incl. splitflanges, metr. screws and O-ring	Example incl. splitflanges, UNC screws and O-ring	Standard sealing material (no additional suffix needed)
Steel, zinc plated, chrome ⁶ -free	CF	WFS32/12GCF	WFS32/12GCFM	WFS32/12GCFU	NBR
Steel, zinc yellow plated	A3C	WFS32/12GA3C	WFS32/12GA3CM	WFS32/12GA3CU	NBR
Stainless steel	SS	WFS32/12GSS	WFS32/12GSSM	WFS32/12GSSU	VIT



GFS-N SAE Flange adapters straight

SAE Flange / Male NPT thread
(ISO 6162-1/-2) (SAE J476)

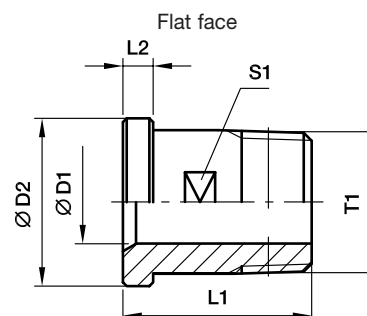
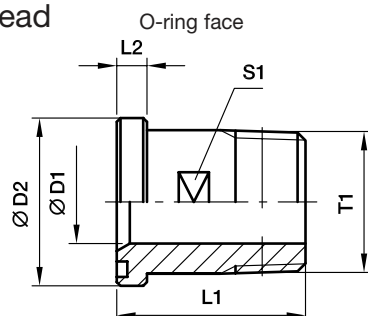

3000 PSI Series

Nom. flange size		T1	D1	D2	L1	L2	S1	Weight (steel) kg/piece	O-ring face Order code*	Flat face Order code*	PN (bar) ¹⁾	
SAE (in)	ISO (DN)										A3C	SS
1/2	13	1/2NPT	12	30.2	50	6.7	19	0.08	GFS32/12N	GFSG32/12N	345	345
1/2	13	3/8NPT	10	30.2	50	6.7	19	0.08	GFS32/38N	GFSG32/38N	345	345
3/4	19	3/4NPT	17	38.1	55	6.7	27	0.16	GFS33/34N	GFSG33/34N	345	345
3/4	19	1/2NPT	12	38.1	55	6.7	27	0.16	GFS33/12N	GFSG33/12N	345	345
1	25	1NPT	22	44.4	60	8.0	32	0.23	GFS34/1N	GFSG34/1N	345	345
1	25	3/4NPT	17	44.4	60	8.0	32	0.23	GFS34/34N	GFSG34/34N	345	345
1 1/4	32	1 1/4NPT	27	50.8	65	8.0	41	0.30	GFS35/114N	GFSG35/114N	276	276
1 1/4	32	1NPT	22	50.8	65	8.0	41	0.30	GFS35/1N	GFSG35/1N	276	276
1 1/2	38	1 1/2NPT	32	60.3	70	8.0	46	0.40	GFS36/112N	GFSG36/112N	207	207
1 1/2	38	1 1/4NPT	27	60.3	70	8.0	46	0.40	GFS36/114N	GFSG36/114N	207	207
2	51	2NPT	40	71.4	75	9.5	55	0.50	GFS38/2N	GFSG38/2N	207	207
2	51	1 1/2NPT	32	71.4	75	9.5	55	0.50	GFS38/112N	GFSG38/112N	207	207

6000 PSI Series

1/2	13	1/2NPT	12	31.8	50	7.7	19	0.09	GFS62/12N	GFSG62/12N	420	420
1/2	13	3/8NPT	10	31.8	50	7.7	19	0.09	GFS62/38N	GFSG62/38N	420	420
3/4	19	3/4NPT	17	41.3	60	8.7	26	0.15	GFS63/34N	GFSG63/34N	420	420
3/4	19	1/2NPT	12	41.3	60	8.7	26	0.15	GFS63/12N	GFSG63/12N	420	420
1	25	1NPT	22	47.6	70	9.5	32	0.23	GFS64/1N	GFSG64/1N	420	420
1	25	3/4NPT	17	47.6	70	9.5	32	0.23	GFS64/34N	GFSG64/34N	420	420
1 1/4	32	1 1/4NPT	27	54.0	75	10.3	36	0.30	GFS65/114N	GFSG65/114N	420	420
1 1/4	32	1NPT	22	54.0	75	10.3	36	0.30	GFS65/1N	GFSG65/1N	420	420
1 1/2	38	1 1/2NPT	32	63.5	80	12.5	46	0.50	GFS66/112N	GFSG66/112N	420	420
1 1/2	38	1 1/4NPT	27	63.5	80	12.5	46	0.50	GFS66/114N	GFSG66/114N	420	420
2	51	2NPT	40	79.4	90	12.5	55	0.80	GFS68/2N	GFSG68/2N	420	420
2	51	1 1/2NPT	32	79.4	90	12.5	55	0.80	GFS68/112N	GFSG68/112N	420	420

¹⁾ Pressure shown = Item deliverable

$$\frac{\text{PN (bar)}}{10} = \text{PN (MPa)}$$

*Please add the suffixes below according to the material / surface required.

Order code suffixes					
Material	Suffix surface and material	Example only flange adapter	Example incl. splitflanges, metr. screws and O-ring	Example incl. splitflanges, UNC screws and O-ring	Standard sealing material (no additional suffix needed)
Steel, zinc plated, chrome ⁶ -free	CF	GFS32/12NCF	GFS32/12NCFM	GFS32/12NCFU	NBR
Steel, zinc yellow plated	A3C	GFS32/12NA3C	GFS32/12NA3CM	GFS32/12NA3CU	NBR
Stainless steel	SS	GFS32/12NSS	GFS32/12NSSM	GFS32/12NSSU	VIT

L(O)HQ SAE Straight flange adapter

SAE Flange / O-Lok® ORFS end
(ISO 6162-1/-2)

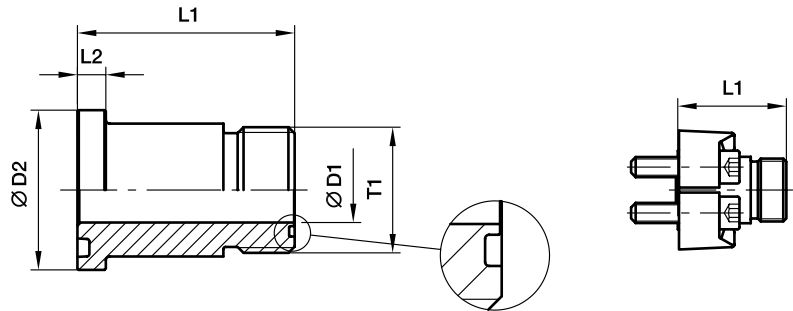

3000 PSI Series

Nom. flange size		Tube		T1	D1	D2	L1	L2	Weight (steel) kg/piece	O-ring face without ORFS	O-ring face include ORFS	PN (bar) ¹⁾	
SAE (in)	ISO (DN)	(metr.)	(in)							O-ring Order code*	O-ring Order code*	S	SS
3/4	19	18, 20	3/4	1 3/16-12UN-2A	15.5	38.1	45.7	6.7	0.21	12LHQ1	12LOHQ1	350	350
1	25	22, 25	7/8, 1	1 7/16-12UN-2A	20.6	44.5	47.8	8.0	0.30	16LHQ1	16LOHQ1	350	350
1 1/4	32	28, 30, 32	1 1/4	1 11/16-12UN-2A	26.0	50.8	46.2	8.0	0.31	20LHQ1	20LOHQ1	280	280
1 1/2	38	35, 38	1 1/2	2-12UN-2A	32.0	60.3	49.3	8.0	0.56	24LHQ1	24LOHQ1	210	210

6000 PSI Series

3/4	19	18, 20	3/4	1 3/16-12UN-2A	15.5	41.3	51.8	8.8	0.21	12LHQ2	12LOHQ2	420	420
1	25	18, 20	3/4	1 3/16-12UN-2A	15.5	47.6	57.2	9.5	0.26	12-16LHQ2	12-16LOHQ2	420	420
1	25	22, 27	3/4, 7/8	1 7/16-12UN-2A	20.6	47.6	57.2	9.5	0.30	16LHQ2	16LOHQ2	420	420
1 1/4	32	28, 30, 32	1 1/4	1 11/16-12UN-2A	26.0	54.0	62.0	10.3	0.31	20LHQ2	20LOHQ2	345	345
1 1/2	38	35, 38	1 1/2	2-12UN-2A	32.0	63.5	66.8	12.6	0.56	24LHQ2	24LOHQ2	310	310

¹⁾ Pressure shown = Item deliverable

PN (bar) = PN (MPa)
10



*Please add the suffixes below according to the material / surface required.

Order code suffixes				
Material	Suffix surface and material	Example only flange adapter without ORFS O-ring	Example only flange adapter incl. ORFS O-ring	Standard sealing material (no additional suffix needed)
Steel, zinc plated, chrome ⁶ -free	CF	12LHQ1-CF	12LOHQ1-CF	NBR
Steel, zinc yellow plated	A3C	12LHQ1-S	12LOHQ1-S	NBR
Stainless steel	SS	12LHQ1-SS	12LOHQ1-SS	VIT

L(O)EMQ SAE 90° Elbow flange adapter

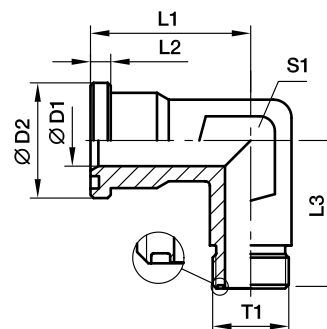
 SAE Flange / O-Lok® ORFS end
 (ISO 6162-1/-2)

3000 PSI Series

Nom. flange size		Tube		T1	D1	D2	L1	L2	L3	S1	Weight (steel) kg/piece	O-ring face without ORFS O-ring	O-ring face include ORFS O-ring	PN (bar) ¹⁾	
SAE (in)	ISO (DN)	(metr.)	(in)									Order code*	Order code*	S	SS
1/2	13	8, 10	3/8	11/16-16UN-2A	6	30.2	44	6.7	50	22	0.40	6-8LEMQ1	6-8LOEMQ1	350	350
1/2	13	12	1/2	13/16-16UN-2A	9	30.2	44	6.7	50	22	0.36	8LEMQ1	8LOEMQ1	350	350
1/2	13	14, 15, 16	5/8	1-14UN-2A	12	30.2	44	6.7	50	22	0.32	10-8LEMQ1	10-8LOEMQ1	350	350
3/4	19	14, 15, 16	5/8	1-14UN-2A	12	38.1	53	6.7	64	27	0.47	10-12LEMQ1	10-12LOEMQ1	350	350
3/4	19	18, 20	3/4	1 3/16-12UN-2A	15	38.1	53	6.7	64	27	0.44	12LEMQ1	12LOEMQ1	350	350
1	25	18, 20	3/4	1 3/16-12UN-2A	15	44.4	60	8.0	65	34	0.52	12-16LEMQ1	12-16LOEMQ1	350	350
1	25	22, 25	7/8, 1	1 7/16-12UN-2A	20	44.4	60	8.0	65	34	0.50	16LEMQ1	16LOEMQ1	350	350
1 1/4	32	22, 25	7/8, 1	1 7/16-12UN-2A	20	50.8	55	8.0	64	42	0.48	16-20LEMQ1	16-20LOEMQ1	278	278
1 1/4	32	28, 30, 32	1 1/4	1 11/16-12UN-2A	26	50.8	55	8.0	64	42	0.56	20LEMQ1	20LOEMQ1	278	278
1 1/2	38	28, 30, 32	1 1/4	1 11/16-12UN-2A	26	60.3	66	8.0	78	50	0.73	20-24LEMQ1	20-24LOEMQ1	207	207
1 1/2	38	35, 38	1 1/2	2-12UN-2A	32	60.3	66	8.0	78	50	0.69	24LEMQ1	24LOEMQ1	207	207

6000 PSI Series

1/2	13	8, 10	3/8	11/16-16UN-2A	6	31.8	44	7.7	50	22	0.40	6-8LEMQ2	6-8LOEMQ2	420	420
1/2	13	12	1/2	13/16-16UN-2A	9	31.8	44	7.7	50	22	0.36	8LEMQ2	8LOEMQ2	420	420
1/2	13	14, 15, 16	5/8	1-14UN-2A	12	31.8	44	7.7	50	22	0.32	10-8LEMQ2	10-8LOEMQ2	420	420
3/4	19	14, 15, 16	5/8	1-14UN-2A	12	41.3	53	8.7	64	27	0.47	10-12LEMQ2	10-12LOEMQ2	420	420
3/4	19	18, 20	3/4	1 3/16-12UN-2A	15	41.3	53	8.7	64	27	0.44	12LEMQ2	12LOEMQ2	420	420
1	25	18, 20	3/4	1 3/16-12UN-2A	15	47.6	60	9.5	62	34	0.52	12-16LEMQ2	12-16LOEMQ2	420	420
1	25	22, 25	7/8, 1	1 7/16-12UN-2A	20	47.6	60	9.5	62	34	0.50	16LEMQ2	16LOEMQ2	420	420
1 1/4	32	22, 25	7/8, 1	1 7/16-12UN-2A	20	54.0	70	10.3	72	42	0.48	16-20LEMQ2	16-20LOEMQ2	420	420
1 1/4	32	28, 30, 32	1 1/4	1 11/16-12UN-2A	26	54.0	70	10.3	72	42	0.56	20LEMQ2	20LOEMQ2	345	345
1 1/2	38	28, 30, 32	1 1/4	1 11/16-12UN-2A	26	63.5	80	12.5	84	50	0.73	20-24LEMQ2	20-24LOEMQ2	345	345
1 1/2	38	35, 38	1 1/2	2-12UN-2A	32	63.5	80	12.5	84	50	0.69	24LEMQ2	24LOEMQ2	310	310

1) Pressure shown = Item deliverable

$$\frac{\text{PN (bar)}}{10} = \text{PN (MPa)}$$

*Please add the suffixes below according to the material / surface required.

Order code suffixes				
Material	Suffix surface and material	Example only flange adapter without ORFS O-ring	Example only flange adapter incl. ORFS O-ring	Standard sealing material (no additional suffix needed)
Steel, zinc plated, chrome ⁶ -free	CF	12LEMQ1CF	12LOEMQ1CF	NBR
Steel, zinc yellow plated	A3C	12LEMQ1A3C	12LOEMQ1A3C	NBR
Stainless steel	SS	12LEMQ1SS	12LOEMQ1SS	VIT

L(O)VQ SAE 45° Elbow flange adapter

SAE Flange / O-Lok® ORFS end
(ISO 6162-1/-2)

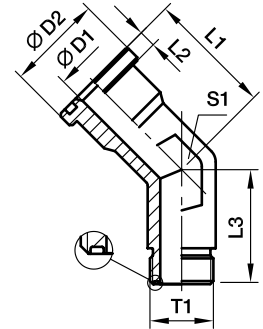

3000 PSI Series

Nom. flange size		Tube		T1	D1	D2	L1	L2	L3	S1	Weight (steel) kg/piece	O-ring face without ORFS O-ring	O-ring face include ORFS O-ring	PN (bar) ¹⁾	
SAE (in)	ISO (DN)	(metr.)	(in)									Order code*	Order code*	S	SS
3/4	19	18, 20	3/4	1 3/16-12UN-2A	15.5	38.1	40	6.7	26	30	0.29	12LVQ1	12LOVQ1	350	350
1	25	22, 25	7/8, 1	1 7/16-12UN-2A	20.5	44.5	47	8.0	30	36	0.39	16LVQ1	16LOVQ1	350	350
1 1/4	32	28, 30, 32	1 1/4	1 11/16-12UN-2A	26.0	50.8	52	8.0	32	41	0.45	20LVQ1	20LOVQ1	280	280
1 1/2	38	35, 38	1 1/2	2-12UN-2A	32.0	60.3	60	8.0	37	48	0.57	24LVQ1	24LOVQ1	210	210

6000 PSI Series

3/4	19	18, 20	3/4	1 3/16-12UN-2A	15.5	41.3	40	8.8	26	30	0.29	12LVQ2	12LOVQ2	420	420
1	25	22, 25	7/8, 1	1 7/16-12UN-2A	20.5	47.6	47	9.5	30	36	0.39	16LVQ2	16LOVQ2	420	420
1 1/4	32	28, 30, 32	1 1/4	1 11/16-12UN-2A	26.0	54.0	52	10.3	32	41	0.45	20LVQ2	20LOVQ2	345	345
1 1/2	38	35, 38	1 1/2	2-12UN-2A	32.0	63.5	60	12.6	37	48	0.57	24LVQ2	24LOVQ2	310	310

¹⁾ Pressure shown = Item deliverable

$\frac{PN \text{ (bar)}}{10} = PN \text{ (MPa)}$



*Please add the suffixes below according to the material / surface required.

Order code suffixes				
Material	Suffix surface and material	Example only flange adapter without ORFS O-ring	Example only flange adapter incl. ORFS O-ring	Standard sealing material (no additional suffix needed)
Steel, zinc plated, chrome ⁶ -free	CF	12LVQ1-CF	12LOVQ1-CF	NBR
Steel, zinc yellow plated	A3C	12LVQ1-S	12LOVQ1-S	NBR
Stainless steel	SS	12LVQ1-SS	12LOVQ1-SS	VIT

XHQ SAE Straight flange adapter

SAE Flange / Triple-Lok® 37° flare end
(ISO 6162-1/-2)

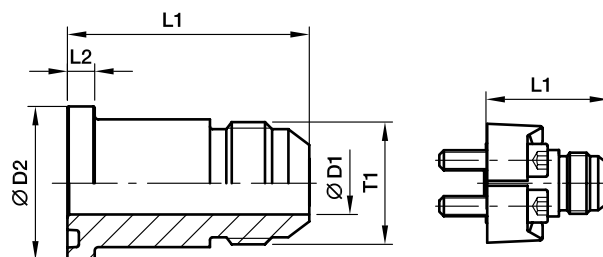

3000 PSI Series

Nom. flange size		Tube		T1	D1	D2	L1	L2	Weight (steel) kg/piece	Order code*	PN (bar) ¹⁾	
SAE (in)	ISO (DN)	(metr.)	(in)								S	SS
3/4	19	18, 20	3/4	1 1/16-12UN-2A	15.5	38.1	50.5	6.7	0.21	12XHQ1	350	350
1	25	22, 25	7/8, 1	1 5/16-12UN-2A	21.5	44.5	53.3	8.0	0.30	16XHQ1	350	350
1 1/4	32	28, 30, 32	1 1/4	1 5/8-12UN-2A	27.5	50.8	53.5	8.0	0.31	20XHQ1	275	275
1 1/2	38	35, 38	1 1/2	1 7/8-12UN-2A	33.5	60.3	59.2	8.0	0.56	24XHQ1	210	210
2	51	50	2	2 1/2-12UN-2A	45.0	71.4	66.3	9.5	1.10	32XHQ1	210	210

6000 PSI Series

3/4	19	18, 20	3/4	1 1/16-12UN-2A	15.5	41.3	56.6	8.8	0.21	12XHQ2	350	350
1	25	22, 25	7/8, 1	1 5/16-12UN-2A	21.5	47.6	62.7	9.5	0.30	16XHQ2	350	350
1 1/4	32	28, 30, 32	1 1/4	1 5/8-12UN-2A	27.5	54.0	68.8	10.3	0.31	20XHQ2	275	275
1 1/2	38	35, 38	1 1/2	1 7/8-12UN-2A	33.5	63.5	76.7	12.6	0.56	24XHQ2	210	210

¹⁾ Pressure shown = Item deliverable

$\frac{PN \text{ (bar)}}{10} = PN \text{ (MPa)}$

*Please add the suffixes below according to the material / surface required.

Material	Order code suffixes		
	Suffix surface and material	Example only flange adapter	Standard sealing material (no additional suffix needed)
Steel, zinc plated, chrome ⁶ -free	CF	12XHQ1-CF	NBR
Steel, zinc yellow plated	A3C	12XHQ1-S	NBR
Stainless steel	SS	12XHQ1-SS	VIT

XEMQ SAE 90° Elbow flange adapter

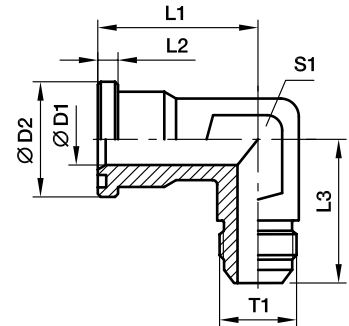
 SAE Flange / Triple-Lok® 37° flare end
 (ISO 6162-1/-2)

3000 PSI Series

Nom. flange size		Tube		T1	D1	D2	L1	L2	L3	S1	Weight (steel) kg/piece	Order code*	PN (bar) ¹⁾	
SAE (in)	ISO (DN)	(metr.)	(in)										S	SS
1/2	13	12	1/2	3/4-16UNF-2A	10	30.2	44	6.7	50	22	0.20	8XEMQ1	350	350
1/2	13	14, 15, 16	5/8	7/8-14UNF-2A	12	30.2	44	6.7	50	22	0.20	10-8XEMQ1	350	350
3/4	19	14, 15, 16	5/8	7/8-14UNF-2A	19	38.1	53	6.7	64	27	0.29	10-12XEMQ1	350	350
3/4	19	18, 20	3/4	1 1/16-12UN-2A	19	38.1	53	6.7	64	27	0.29	12XEMQ1	350	350
3/4	19	25	1	1 5/16-12UN-2A	19	38.1	53	6.7	64	27	0.29	16-12XEMQ1	350	350
1	25	18, 20	3/4	1 1/16-12UN-2A	22	44.4	60	8.0	65	34	0.39	12-16XEMQ1	350	350
1	25	25	1	1 5/16-12UN-2A	22	44.4	60	8.0	65	34	0.39	16XEMQ1	350	350
1	25	30, 32	1 1/4	1 5/8-12UN-2A	22	44.4	60	8.0	65	34	0.39	20-16XEMQ1	275	275
1 1/4	32	25	1	1 5/16-12UN-2A	28	50.8	55	8.0	64	42	0.45	16-20XEMQ1	275	275
1 1/4	32	30, 32	1 1/4	1 5/8-12UN-2A	28	50.8	55	8.0	64	42	0.45	20XEMQ1	275	275
1 1/2	38	30, 32	1 1/4	1 5/8-12UN-2A	35	60.3	66	8.0	78	50	0.57	20-24XEMQ1	210	210
1 1/2	38	38	1 1/2	1 7/8-12UN-2A	35	60.3	66	8.0	78	50	0.57	24XEMQ1	210	210

6000 PSI Series

1/2	13	12	1/2	3/4-16UNF-2A	12	31.8	44	7.7	50	22	0.20	8XEMQ2	350	350
1/2	13	14, 15, 16	5/8	7/8-14UNF-2A	12	31.8	44	7.7	50	22	0.20	10-8XEMQ2	350	350
3/4	19	14, 15, 16	5/8	7/8-14UNF-2A	18	41.3	53	8.7	64	27	0.29	10-12XEMQ2	350	350
3/4	19	18, 20	3/4	1 1/16-12UN-2A	18	41.3	53	8.7	64	27	0.29	12XEMQ2	350	350
3/4	19	25	1	1 5/16-12UN-2A	18	41.3	53	8.7	64	27	0.29	16-12XEMQ2	350	350
1	25	18, 20	3/4	1 1/16-12UN-2A	22	47.6	60	9.5	62	34	0.39	12-16XEMQ2	350	350
1	25	25	1	1 5/16-12UN-2A	22	47.6	60	9.5	62	34	0.39	16XEMQ2	350	350
1	25	30, 32	1 1/4	1 5/8-12UN-2A	22	47.6	60	9.5	62	34	0.39	20-16XEMQ2	275	275
1 1/4	32	25	1	1 5/16-12UN-2A	27	54.0	70	10.3	70	42	0.45	16-20XEMQ2	350	350
1 1/4	32	30, 32	1 1/4	1 5/8-12UN-2A	27	54.0	70	10.3	72	42	0.45	20XEMQ2	275	275
1 1/2	38	30, 32	1 1/4	1 5/8-12UN-2A	32	63.5	80	12.5	87	50	0.57	20-24XEMQ2	275	275
1 1/2	38	38	1 1/2	1 7/8-12UN-2A	32	63.5	80	12.5	87	50	0.57	24XEMQ2	210	210

1) Pressure shown = Item deliverable

$$\frac{\text{PN (bar)}}{10} = \text{PN (MPa)}$$

*Please add the suffixes below according to the material / surface required.

Material	Order code suffixes		
	Suffix surface and material	Example only flange adapter	Standard sealing material (no additional suffix needed)
Steel, zinc plated, chrome ⁶ -free	CF	8XEMQ1CF	NBR
Steel, zinc yellow plated	A3C	8XEMQ1A3C	NBR
Stainless steel	SS	8XEMQ1SS	VIT

XVQ SAE 45° Elbow flange adapter

SAE Flange / Triple-Lok® 37° flare end
(ISO 6162-1/-2)

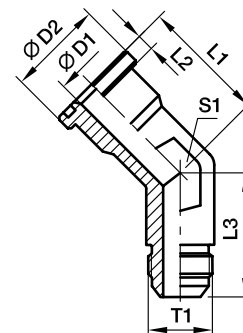

3000 PSI Series

Nom. flange size		Tube		T1	D1	D2	L1	L2	L3	S1	Weight (steel) kg/piece	Order code*	PN (bar) ¹⁾	
SAE (in)	ISO (DN)	(metr.)	(in)										S	SS
3/4	19	18, 20	3/4	1 1/16-12UN-2A	15.5	38.1	40.1	6.7	32.5	1 1/16	0.29	12XVQ1	350	350
1	25	22, 25	7/8, 1	1 5/16-12UN-2A	21.4	44.5	47.0	8.0	37.3	1 5/16	0.39	16XVQ1	350	350
1 1/4	32	28, 30, 32	1 1/4	1 5/8-12UN-2A	27.4	50.8	51.8	8.0	40.4	1 5/8	0.45	20XVQ1	275	275
1 1/2	38	35, 38	1 1/2	1 7/8-12UN-2A	33.3	60.3	60.5	8.0	45.2	1 7/8	0.57	24XVQ1	210	210
2	51	50	2	2 1/2-12UN-2A	45.2	71.4	76.2	9.5	56.4	2 1/2	1.15	32XVQ1	210	210

6000 PSI Series

3/4	19	18, 20	3/4	1 1/16-12UN-2A	15.5	41.3	40.1	8.8	32.5	1 1/16	0.42	12XVQ2	350	350
1	25	22, 25	7/8, 1	1 5/16-12UN-2A	21.4	47.6	47.0	9.5	37.3	1 5/16	0.52	16XVQ2	350	350
1 1/4	32	28, 30, 32	1 1/4	1 5/8-12UN-2A	27.4	54.0	51.8	10.3	40.4	1 5/8	0.56	20XVQ2	275	275
1 1/2	38	35, 38	1 1/2	1 7/8-12UN-2A	33.3	63.5	60.5	12.6	45.2	1 7/8	0.69	24XVQ2	210	210

¹⁾ Pressure shown = Item deliverable

$\frac{PN (bar)}{10} = PN (MPa)$

*Please add the suffixes below according to the material / surface required.

Material	Order code suffixes		
	Suffix surface and material	Example only flange adapter	Standard sealing material (no additional suffix needed)
Steel, zinc plated, chrome ⁶ -free	CF	12XVQ1-CF	NBR
Steel, zinc yellow plated	A3C	12XVQ1-S	NBR
Stainless steel	SS	12XVQ1-SS	VIT

ASR SAE Straight flange adapter

SAE Flange / Butt weld reducer tube end
(ISO 6162-1/-2)

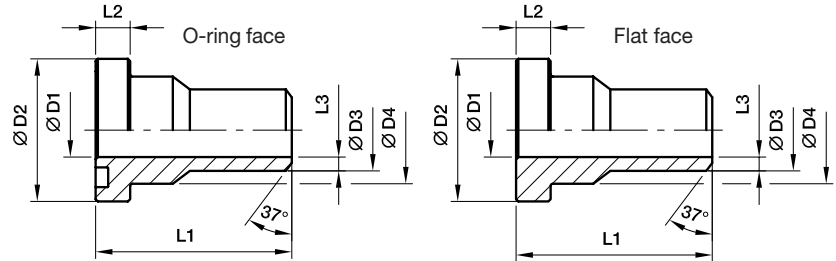

3000 PSI Series

Nom. flange size		Tube	D1	D2	D3	D4	L1	L2	L3	Weight (steel) kg/piece	O-ring face	Flat face	PN (bar) ¹⁾	
SAE (in)	ISO (DN)										Order code*	Order code*	S	SS
1/2	13	18 4.5	10	30.2	18.0	24.0	45	6.7	4.0	0.30	ASR32/18X4.5	ASRG32/18X4.5	345	345
3/4	19	22 4.5	13	38.1	22.0	31.5	50	6.7	4.5	0.40	ASR33/22X4.5	ASRG33/22X4.5	345	345
1	25	28 4.5	19	44.4	28.0	38.0	55	8.0	4.5	0.49	ASR34/28X4.5	ASRG34/28X4.5	345	345
1 1/4	32	35 5	25	50.8	35.0	43.0	60	8.0	5.0	0.75	ASR35/35X5	ASRG35/35X5	276	276
1 1/2	38	43 6	31	60.3	43.0	50.0	65	8.0	6.0	1.01	ASR36/43X6	ASRG36/43X6	207	207
2	51	50 6	38	71.4	50.0	62.0	70	9.5	6.0	1.15	ASR38/50X6	ASRG38/50X6	207	207
2 1/2	64	62 7.5	47	84.1	62.0	74.0	75	9.5	7.5	1.40	ASR310/62X7.5	ASRG310/62X7.5	172	172
3	76	76 9	58	101.6	76.0	90.0	85	9.5	9.0	1.76	ASR312/76X9	ASRG312/76X9	138	138
3 1/2	89	90 10	70	114.3	90.0	102.0	90	11.2	10.0	2.15	ASR314/90X10	ASRG314/90X10	34	34
4	102	102 7	88	127.0	102.0	114.0	100	11.2	7.0	2.35	ASR316/102X7	ASRG316/102X7	34	34

6000 PSI Series

1/2	13	18 4	10	31.8	18.0	24.0	45	7.7	4.0	0.40	ASR62/18X4	ASRG62/18X4	420	420
3/4	19	22 4.5	13	41.3	22.0	32.0	50	8.7	4.5	0.50	ASR63/22X4.5	ASRG63/22X4.5	420	420
1	25	28 5	18	47.6	28.0	38.0	55	9.5	5.0	0.90	ASR64/28X5	ASRG64/28X5	420	420
1 1/4	32	35 6.5	22	54.0	35.0	44.0	60	10.3	6.5	1.35	ASR65/35X6.5	ASRG65/35X6.5	420	420
1 1/2	38	44 7.5	29	63.5	44.0	51.0	65	12.5	7.5	2.65	ASR66/44X7.5	ASRG66/44X7.5	420	420
2	51	51 8	35	79.4	51.0	67.0	70	12.5	8.0	3.90	ASR68/51X8	ASRG68/51X8	420	420

¹⁾ Pressure shown = Item deliverable

$$\frac{PN \text{ (bar)}}{10} = PN \text{ (MPa)}$$

The pressures given here are the maximum allowable for the flange fittings. If the pipe or tube used has a lower pressure rating, then the welded assembly rating will be the lower one, assuming the weld is adequately strong.

*Please add the suffixes below according to the material / surface required.

Order code suffixes					
Material	Suffix surface and material	Example only flange adapter	Example incl. splitflanges, metr. screws and O-ring	Example incl. splitflanges, UNC screws and O-ring	Standard sealing material (no additional suffix needed)
Steel, blanc oil dipped	S	ASR32/18X4.5S	ASR32/18X4.5SM	ASR32/18X4.5SU	NBR
Stainless steel	SS	ASR32/18X4.5SS	ASR32/18X4.5SSM	ASR32/18X4.5SSU	VIT



AS SAE Straight flange adapter

SAE Flange / Butt weld tube end
(ISO 6162-1/-2)

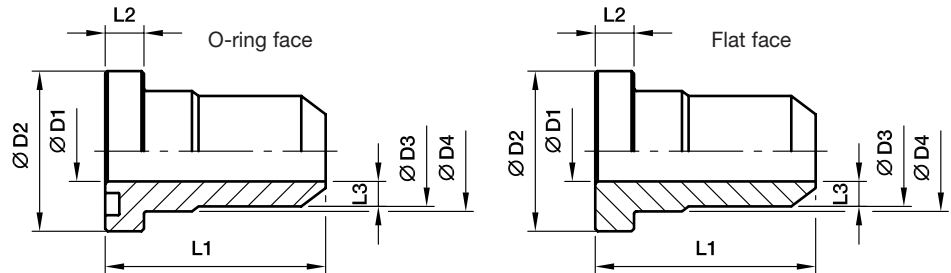

3000 PSI Series

Nom. flange size		Tube	D1	D2	D3	D4	L1	L2	L3	Weight (steel) kg/piece	O-ring face Order code*	Flat face Order code*	PN (bar) ¹⁾	
SAE (in)	ISO (DN)												S	SS
1/2	13	15 2	11	30.2	23.9	23.9	38	6.7	6.5	0.26	AS32/15X2	ASG32/15X2	345	345
1/2	13	16 3	10	30.2	23.9	23.9	38	6.7	7.0	0.27	AS32/16X3	ASG32/16X3	345	345
1/2	13	21.3 2.6	13	30.2	22.0	24.0	45	6.7	4.5	0.29	AS32/21.3X2.6	ASG32/21.3X2.6	345	345
3/4	19	18 1.5	15	38.1	31.8	31.8	50	8.0	8.4	0.51	AS33/18X1.5	ASG33/18X1.5	345	345
3/4	19	22 2	18	38.1	31.8	31.8	50	8.0	6.9	0.49	AS33/22X2	ASG33/22X2	345	345
3/4	19	20 3	14	38.1	31.8	31.8	50	8.0	8.9	0.52	AS33/20X3	ASG33/20X3	345	345
3/4	19	25 4	17	38.1	31.8	31.8	50	8.0	7.4	0.49	AS33/25X4	ASG33/25X4	345	345
3/4	19	26.9 2.6	19	38.1	28.0	31.5	50	6.7	4.5	0.51	AS33/26.9X2.6	ASG33/26.9X2.6	345	345
1	25	28 2	24	44.5	38.0	38.0	50	8.0	7.0	0.59	AS34/28X2	ASG34/28X2	345	345
1	25	30 4.5	21	44.5	38.0	38.0	50	8.0	8.5	0.62	AS34/30X4.5	ASG34/30X4.5	345	345
1	25	33.7 4	25	44.4	35.0	38.0	55	8.0	5.0	0.70	AS34/33.7X4	ASG34/33.7X4	345	345
1 1/4	32	35 2	31	50.8	43.0	43.0	55	8.0	6.0	0.75	AS35/35X2	ASG35/35X2	276	276
1 1/4	32	25 3	19	50.8	43.0	43.0	55	8.0	12.0	0.89	AS35/25X3	ASG35/25X3	276	276
1 1/4	32	30 4	22	50.8	43.0	43.0	55	8.0	10.5	0.88	AS35/30X4	ASG35/30X4	276	276
1 1/4	32	38 5	28	50.8	43.0	43.0	55	8.0	7.5	0.81	AS35/38X5	ASG35/38X5	276	276
1 1/4	32	42.4 5.0	31	50.8	43.0	43.0	60	8.0	6.0	0.92	AS35/42.4X5	ASG35/42.4X5	276	276
1 1/2	38	42 3	36	60.3	50.0	50.0	57	8.0	7.0	1.03	AS36/42X3	ASG36/42X3	207	207
1 1/2	38	38 4	30	60.3	50.0	50.0	57	8.0	10.0	1.17	AS36/38X4	ASG36/38X4	207	207
1 1/2	38	48.3 5.0	38	60.3	50.0	50.0	65	8.0	6.0	1.21	AS36/48.3X5	ASG36/48.3X5	207	207
2	51	50 6	38	71.4	62.0	62.0	62	9.5	12.0	1.49	AS38/50X6	ASG38/50X6	207	207
2	51	65 8	49	71.4	65.0	65.0	62	9.5	8.0	1.38	AS38/65X8	ASG38/65X8	207	207
2	51	60.3 6.3	47	71.4	62.0	62.0	70	9.5	7.5	1.25	AS38/62X7.5	ASG38/62X7.5	207	207
2 1/2	64	76.1 5.5	63	84.1	74.0	74.0	75	9.5	5.5	1.50	AS310/74X5.5	ASG310/74X5.5	172	172
3	76	88.9 10	70	101.6	90.0	90.0	85	9.5	10.0	2.11	AS312/90X10	ASG312/90X10	138	138
3 1/2	89	101.6 7.0	88	114.3	102.0	102.0	90	11.2	7.0	2.51	AS314/102X7	ASG314/102X7	34	34
4	102	115 8.5	98	127.0	115.0	114.0	100	11.2	8.5	2.75	AS316/115X8.5	ASG316/115X8.5	34	34
5	127	139.7 10	120	152.4	140.0	140.0	100	11.2	10.0	3.41	AS320/140X10	ASG320/140X10	34	34

1) Pressure shown = Item deliverable

$$\frac{PN \text{ (bar)}}{10} = PN \text{ (MPa)}$$

The pressures given here are the maximum allowable for the flange fittings. If the pipe or tube used has a lower pressure rating, then the welded assembly rating will be the lower one, assuming the weld is adequately strong.

*Please add the suffixes below according to the material / surface required.

Order code suffixes					
Material	Suffix surface and material	Example only flange adapter	Example incl. splitflanges, metr. screws and O-ring	Example incl. splitflanges, UNC screws and O-ring	Standard sealing material (no additional suffix needed)
Steel, blanc oil dipped	S	AS32/15X2S	AS32/15X2SM	AS32/15X2SU	NBR
Stainless steel	SS	AS32/15X2SS	AS32/15X2SSM	AS32/15X2SSU	VIT

AS SAE Straight flange adapter

SAE Flange / Butt weld tube end
(ISO 6162-1/-2)

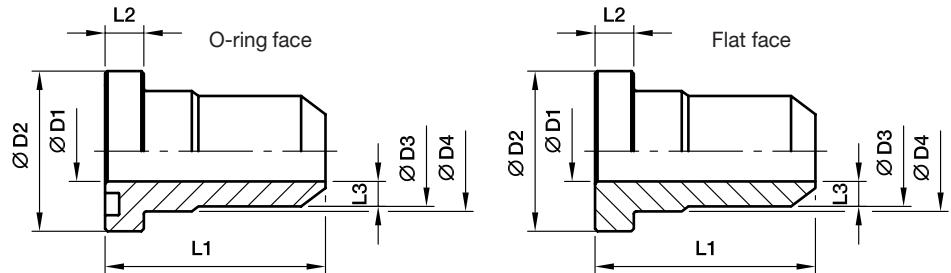

6000 PSI Series

Nom. flange size		Tube	D1	D2	D3	D4	L1	L2	L3	Weight (steel) kg/piece	O-ring face Order code*	Flat face Order code*	PN (bar) ¹⁾	
SAE (in)	ISO (DN)												S	SS
1/2	13	16 3	10	31.8	23.9	23.9	41	7.7	7.0	0.36	AS62/16X3	ASG62/16X3	420	420
1/2	13	21.3 3.2	13	31.8	22.0	24.0	45	7.7	4.5	0.45	AS62/21.3X3.2	ASG62/21.3X3.2	420	420
3/4	19	16 3	10	41.3	31.8	31.8	55	8.7	10.9	0.85	AS63/16X3	ASG63/16X3	420	420
3/4	19	20 4	12	41.3	31.8	31.8	55	8.7	9.9	0.79	AS63/20X4	ASG63/20X4	420	420
3/4	19	26.9 4	18	41.3	28.0	32.0	50	8.7	5.0	0.74	AS63/26.9X4	ASG63/26.9X4	420	420
3/4	19	25 5	15	41.3	31.8	31.8	55	8.7	8.4	0.75	AS63/25X5	ASG63/25X5	420	420
1	25	25 5	15	47.3	38.0	38.0	67	9.5	11.5	1.20	AS64/25X5	ASG64/25X5	420	420
1	25	30 4	22	47.3	38.0	38.0	67	9.5	8.0	1.10	AS64/30X4	ASG64/30X4	420	420
1	25	30 6	18	47.3	38.0	38.0	67	9.5	10.0	1.15	AS64/30X6	ASG64/30X6	420	420
1	25	33.7 6.3	22	47.6	35.0	38.0	55	9.5	6.5	1.21	AS64/33.7X6.3	ASG64/33.7X6.3	420	420
1 1/4	32	30 4	22	54.0	43.7	43.7	78	10.2	10.8	1.82	AS65/30X4	ASG65/30X4	420	420
1 1/4	32	30 6	18	54.0	43.7	43.7	78	10.2	12.8	1.92	AS65/30X6	ASG65/30X6	420	420
1 1/4	32	38 5	28	54.0	43.7	43.7	78	10.2	7.8	1.70	AS65/38X5	ASG65/38X5	420	420
1 1/4	32	38 8	22	54.0	43.7	43.7	78	10.2	10.8	1.72	AS65/38X8	ASG65/38X8	420	420
1 1/4	32	42.4 6.3	29	54.0	44.0	44.0	60	10.3	7.5	1.85	AS65/42.4X6.3	ASG65/42.4X6.3	420	420
1 1/2	38	38 5	28	63.5	50.8	50.8	85	12.5	11.4	2.71	AS66/38X5	ASG66/38X5	420	420
1 1/2	38	38 8	22	63.5	50.8	50.8	85	12.5	14.4	2.85	AS66/38X8	ASG66/38X8	420	420
1 1/2	38	48.3 8	35	63.5	51.0	51.0	65	12.5	8.0	2.90	AS66/48.3X8	ASG66/48.3X8	420	420
2	51	50 9	32	79.4	66.6	66.6	116	12.5	17.3	5.01	AS68/50X9	ASG68/50X9	420	420
2	51	65 8	49	79.4	66.6	66.6	116	12.5	8.8	4.37	AS68/65X8	ASG68/65X8	420	420
2	51	60.3 10	43	79.4	61.0	67.0	70	12.5	9.0	4.52	AS68/60.3X10	ASG68/60.3X10	420	420
2 1/2	64	73 14	45	107.8	74.0	88.9	90	20.6	14.5	6.41	AS610/73X14	ASG610/73X14	420	420
3	76	88.6 16	58	131.7	90.0	113.8	110	25.6	16.0	9.31	AS612/88.6X16	ASG612/88.6X16	420	420

¹⁾ Pressure shown = Item deliverable

$$\frac{PN \text{ (bar)}}{10} = PN \text{ (MPa)}$$

The pressures given here are the maximum allowable for the flange fittings. If the pipe or tube used has a lower pressure rating, then the welded assembly rating will be the lower one, assuming the weld is adequately strong.

*Please add the suffixes below according to the material / surface required.

Order code suffixes					
Material	Suffix surface and material	Example only flange adapter	Example incl. splitflanges, metr. screws and O-ring	Example incl. splitflanges, UNC screws and O-ring	Standard sealing material (no additional suffix needed)
Steel, blanc oil dipped	S	AS62/16X3S	AS62/16X3SM	AS62/16X3SU	NBR
Stainless steel	SS	AS62/16X3SS	AS62/16X3SSM	AS62/16X3SSU	VIT

ASL SAE Straight flange adapter

SAE Flange / Butt weld tube end
(ISO 6162-1/-2)

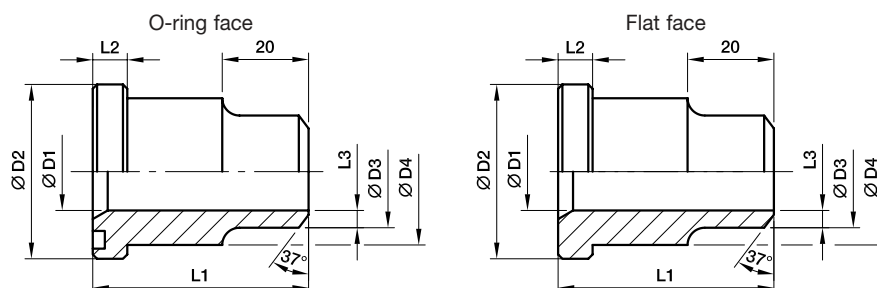

3000 PSI Series

Nom. flange size		Tube	D1	D2	D3	D4	L1	L2	L3	Weight (steel) kg/piece	O-ring face Order code*	Flat face Order code*	PN (bar) ¹⁾	
SAE (in)	ISO (DN)												S	SS
1/2	13	16 2	12	30.2	17	23.9	41	6.7	2.5	0.26	ASL32/16X2	ASLG32/16X2	210	210
3/4	19	25 3	19	38.1	25	31.7	50	6.7	3.0	0.45	ASL33/25X3	ASLG33/25X3	210	210
1	25	30 4	22	44.4	30	38.0	50	8.0	4.0	0.59	ASL34/30X4	ASLG34/30X4	210	210
1 1/4	32	38 5	28	50.8	38	43.0	55	8.0	5.0	0.82	ASL35/38X5	ASLG35/38X5	210	210
1 1/2	38	45 5	35	60.3	45	50.0	57	8.0	5.0	1.10	ASL36/45X5	ASLG36/45X5	210	210
2	51	60 7	45	71.4	60	62.0	57	9.5	7.5	1.35	ASL38/60X7	ASLG38/60X7	210	210
2 1/2	64	70 7.5	55	84.1	70	74.0	58	9.5	7.5	1.52	ASL310/70X7.5	ASLG310/70X7.5	175	175
3	76	80 6	68	101.6	80	90.0	60	9.5	6.0	2.13	ASL312/80X6	ASLG312/80X6	138	138
3 1/2	89	100 6	88	114.3	100	102.0	60	11.2	6.0	2.41	ASL314/100X6	ASLG314/100X6	35	35
4	102	110 6	98	127.0	110	114.0	60	11.2	6.0	2.52	ASL316/110X6	ASLG316/110X6	35	35
5	127	133 6.5	120	152.4	133	140.0	60	11.2	6.5	3.12	ASL320/133X6.5	ASLG320/133X6.5	35	35

6000 PSI Series

1/2	13	16 2	12	31.8	16	24.0	34	7.7	2.0	0.32	ASL62/16X2	ASLG62/16X2	420	420
3/4	19	25 3.5	18	41.3	25	32.0	38	8.7	3.5	0.70	ASL63/25X3.5	ASLG63/25X3.5	420	420
1	25	30 4	22	47.6	30	38.5	40	9.5	4.0	1.10	ASL64/30X4	ASLG64/30X4	420	420
1 1/4	32	38 5.5	27	54.0	38	44.0	45	10.3	5.5	1.70	ASL65/38X5.5	ASLG65/38X5.5	420	420
1 1/2	38	45 6.5	32	63.5	45	51.0	50	12.5	6.5	2.85	ASL66/45X6.5	ASLG66/45X6.5	420	420
2	51	60 7.5	45	79.4	60	67.0	58	12.5	7.5	4.60	ASL68/60X7.5	ASLG68/60X7.5	420	420
2 1/2	64	74 14.5	45	107.8	74	88.9	90	20.6	14.5	6.50	ASL610/74X14.5	ASLG610/74X14.5	420	420
3	76	90 16	58	131.7	90	113.8	110	25.6	16.0	9.62	ASL612/90X16	ASLG612/90X16	420	420

1) Pressure shown = Item deliverable

$$\frac{\text{PN (bar)}}{10} = \text{PN (MPa)}$$

The pressures given here are the maximum allowable for the flange fittings. If the pipe or tube used has a lower pressure rating, then the welded assembly rating will be the lower one, assuming the weld is adequately strong.

*Please add the suffixes below according to the material / surface required.

Order code suffixes					
Material	Suffix surface and material	Example only flange adapter	Example incl. splitflanges, metr. screws and O-ring	Example incl. splitflanges, UNC screws and O-ring	Standard sealing material (no additional suffix needed)
Steel, blanc oil dipped	S	ASL32/16X2S	ASL32/16X2SM	ASL32/16X2SU	NBR
Stainless steel	SS	ASL32/16X2SS	ASL32/16X2SSM	ASL32/16X2SSU	VIT

WAS SAE 90° Elbow flange adapter

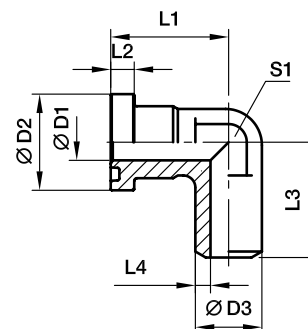
 SAE Flange / Butt weld tube end
 (ISO 6162-1/-2)

3000 PSI Series

Nom. flange size		max.	D1	D2	D3	L1	L2	L3	L4	S1	Weight (steel) kg/piece	Order code*	PN (bar) ¹⁾	
SAE (in)	ISO (DN)												S	SS
1/2	13	21.3	13	30.2	21.6	44	6.7	50	4.3	22	0.38	WAS32/21.6	345	345
3/4	19	26.9	19	38.1	27.2	53	6.7	64	4.1	27	0.64	WAS33/27.2	345	345
1	25	33.7	25	44.4	34.5	60	8.0	65	4.7	34	1.13	WAS34/34.5	345	345
1 1/4	32	42.4	30	50.8	42.8	55	8.0	64	6.4	42	1.27	WAS35/42.8	276	276
1 1/2	38	48.3	38	60.3	48.6	66	8.0	78	5.3	50	2.04	WAS36/48.6	207	207

6000 PSI Series

1/2	13	21.3	13	31.8	21.6	44	7.7	50	4.3	22	0.48	WAS62/21.6	420	420
3/4	19	26.9	18	41.3	27.2	53	8.7	64	4.6	27	0.96	WAS63/27.2	420	420
1	25	33.7	22	47.6	34.5	60	9.5	62	6.3	34	1.42	WAS64/34.5	420	420
1 1/4	32	42.4	28	54.0	42.8	70	10.3	72	7.4	42	2.45	WAS65/42.8	420	420
1 1/2	38	48.3	32	63.5	48.6	80	12.5	84	8.3	50	3.25	WAS66/48.6	420	420

1) Pressure shown = Item deliverable

$$\frac{\text{PN (bar)}}{10} = \text{PN (MPa)}$$

The pressures given here are the maximum allowable for the flange fittings. If the pipe or tube used has a lower pressure rating, then the welded assembly rating will be the lower one, assuming the weld is adequately strong.



*Please add the suffixes below according to the material / surface required.

Order code suffixes					
Material	Suffix surface and material	Example only flange adapter	Example incl. splitflanges, metr. screws and O-ring	Example incl. splitflanges, UNC screws and O-ring	Standard sealing material (no additional suffix needed)
Steel, blanc oil dipped	S	WAS32/21.6S	WAS32/21.6SM	WAS32/21.6SU	NBR
Stainless steel	SS	WAS32/21.6SS	WAS32/21.6SSM	WAS32/21.6SSU	VIT

ES SAE Straight flange adapter

SAE Flange / Socket weld tube end
(ISO 6162-1/-2)

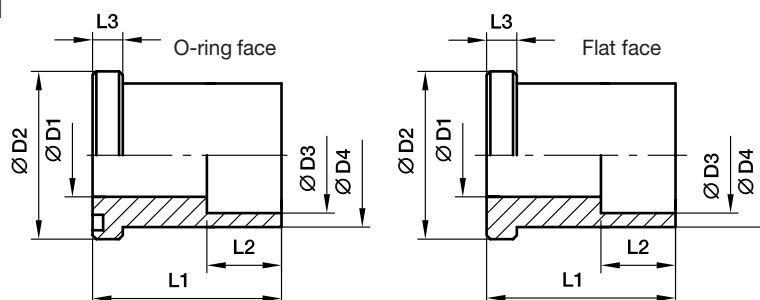

3000 PSI Series

Nom. flange size		max.	D1	D2	D3	D4	L1	L2	L3	Weight (steel) kg/piece	O-ring face Order code*	Flat face Order code*	PN (bar) ¹⁾	
SAE (in)	ISO (DN)												S	SS
1/2	13	16.0	12.5	30.2	16.5	24.0	35	12	6.7	0.25	ES32/16.5	ESG32/16.5	345	345
1/2	13	17.3	12.5	30.2	17.6	24.0	35	12	6.7	0.23	ES32/17.6	ESG32/17.6	345	345
3/4	19	20.0	15.0	38.1	20.5	31.5	40	13	6.7	0.35	ES33/20.5	ESG33/20.5	345	345
3/4	19	21.3	15.0	38.1	21.7	31.5	40	13	6.7	0.32	ES33/21.7	ESG33/21.7	345	345
1	25	25.0	20.0	44.4	25.5	38.0	45	14	8.0	0.45	ES34/25.5	ESG34/25.5	345	345
1	25	26.9	20.0	44.4	27.3	38.0	45	14	8.0	0.41	ES34/27.3	ESG34/27.3	345	345
1 1/4	32	30.0	25.0	50.8	30.5	43.0	50	16	8.0	0.65	ES35/30.5	ESG35/30.5	276	276
1 1/4	32	32.0	25.0	50.8	32.5	43.0	50	16	8.0	0.63	ES35/32.5	ESG35/32.5	276	276
1 1/4	32	33.7	25.0	50.8	34.2	43.0	50	16	8.0	0.61	ES35/34.2	ESG35/34.2	276	276
1 1/2	38	38.0	32.0	60.3	38.5	50.0	55	18	8.0	0.89	ES36/38.5	ESG36/38.5	207	207
1 1/2	38	40.0	32.0	60.3	40.7	50.0	55	18	8.0	0.86	ES36/40.7	ESG36/40.7	207	207
1 1/2	38	42.4	32.0	60.3	43.0	50.0	55	18	8.0	0.95	ES36/43	ESG36/43	207	207
2	51	48.3	32.0	71.4	49.0	62.0	65	20	9.5	1.21	ES38/49	ESG38/49	207	207
2	51	50.0	38.0	71.4	50.7	62.0	65	20	9.5	1.17	ES38/50.7	ESG38/50.7	207	207
2 1/2	64	60.3	38.0	84.1	61.0	74.0	75	22	9.5	1.45	ES310/61	ESG310/61	172	172
2 1/2	64	63.5	47.0	84.1	64.0	74.0	75	22	9.5	1.41	ES310/64	ESG310/64	172	172
3	76	73.5	47.0	101.6	74.0	90.0	85	24	9.5	2.50	ES312/74	ESG312/74	138	138
3	76	76.1	58.0	101.6	77.0	90.0	85	24	9.5	2.45	ES312/77	ESG312/77	138	138
3	76	80.0	58.0	101.6	81.0	90.0	85	24	9.5	2.30	ES312/81	ESG312/81	138	138

¹⁾ Pressure shown = Item deliverable

$$\frac{\text{PN (bar)}}{10} = \text{PN (MPa)}$$

The pressures given here are the maximum allowable for the flange fittings. If the pipe or tube used has a lower pressure rating, then the welded assembly rating will be the lower one, assuming the weld is adequately strong.

*Please add the suffixes below according to the material / surface required.

Order code suffixes					
Material	Suffix surface and material	Example only flange adapter	Example incl. splitflanges, metr. screws and O-ring	Example incl. splitflanges, UNC screws and O-ring	Standard sealing material (no additional suffix needed)
Steel, blanc oil dipped	S	ES32/16.5S	ES32/16.5SM	ES32/16.5SU	NBR
Stainless steel	SS	ES32/16.5SS	ES32/16.5SSM	ES32/16.5SSU	VIT

ES SAE Straight flange adapter

SAE Flange / Socket weld tube end
(ISO 6162-1/-2)

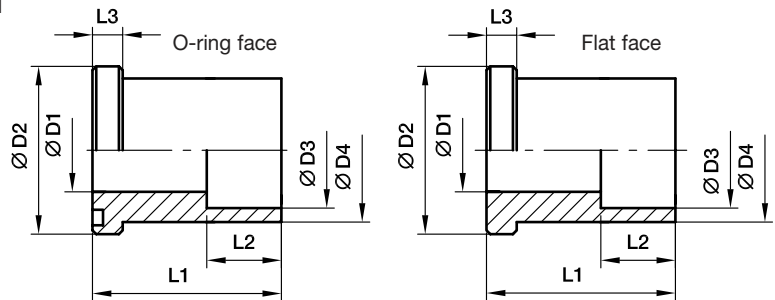

6000 PSI Series

Nom. flange size		max.	D1	D2	D3	D4	L1	L2	L3	Weight (steel) kg/piece	O-ring face Order code*	Flat face Order code*	PN (bar) ¹⁾	
SAE (in)	ISO (DN)												S	SS
1/2	13	16.0	11.0	31.8	16.5	24.0	35	13	7.7	0.26	ES62/16.5	ESG62/16.5	420	420
1/2	13	17.3	11.0	31.8	17.6	24.0	35	13	7.7	0.24	ES62/17.6	ESG62/17.6	420	420
3/4	13	20.0	15.0	41.3	20.5	31.8	40	13	8.7	0.37	ES63/20.5	ESG63/20.5	420	420
3/4	19	21.3	15.0	41.3	21.7	31.8	40	13	8.7	0.33	ES63/21.7	ESG63/21.7	420	420
1	25	25.0	20.0	47.6	25.5	38.0	45	13	9.5	0.48	ES64/25.5	ESG64/25.5	420	420
1	25	26.9	20.0	47.6	27.3	38.0	45	13	9.5	0.43	ES64/27.3	ESG64/27.3	420	420
1 1/4	32	30.0	24.0	54.0	30.5	44.0	50	16	10.3	0.68	ES65/30.5	ESG65/30.5	420	420
1 1/4	32	32.0	24.0	54.0	32.5	44.0	50	16	10.3	0.65	ES65/32.5	ESG65/32.5	420	420
1 1/4	32	33.7	24.0	54.0	34.2	44.0	50	16	10.3	0.64	ES65/34.2	ESG65/34.2	420	420
1 1/2	38	38.0	31.0	63.5	38.5	51.0	55	18	12.5	0.92	ES66/38.5	ESG66/38.5	420	420
1 1/2	38	40.0	31.0	63.5	40.7	51.0	55	18	12.5	0.88	ES66/40.7	ESG66/40.7	420	420
1 1/2	38	42.4	31.0	63.5	42.8	51.0	55	18	12.5	0.85	ES66/42.8	ESG66/42.8	420	420
2	51	48.3	38.0	79.4	49.0	67.0	65	20	12.5	1.25	ES68/49	ESG68/49	420	420
2	51	50.0	38.0	79.4	50.7	67.0	65	20	12.5	1.21	ES68/50.7	ESG68/50.7	420	420

¹⁾ Pressure shown = Item deliverable

$$\frac{PN \text{ (bar)}}{10} = PN \text{ (MPa)}$$

The pressures given here are the maximum allowable for the flange fittings. If the pipe or tube used has a lower pressure rating, then the welded assembly rating will be the lower one, assuming the weld is adequately strong.



*Please add the suffixes below according to the material / surface required.

Order code suffixes					
Material	Suffix surface and material	Example only flange adapter	Example incl. splitflanges, metr. screws and O-ring	Example incl. splitflanges, UNC screws and O-ring	Standard sealing material (no additional suffix needed)
Steel, blanc oil dipped	S	ES62/16.5S	ES62/16.5SM	ES62/16.5SU	NBR
Stainless steel	SS	ES62/16.5SS	ES62/16.5SSM	ES62/16.5SSU	VIT

ESL SAE Straight flange adapter

SAE Flange / Socket weld tube end
(ISO 6162-1/-2)

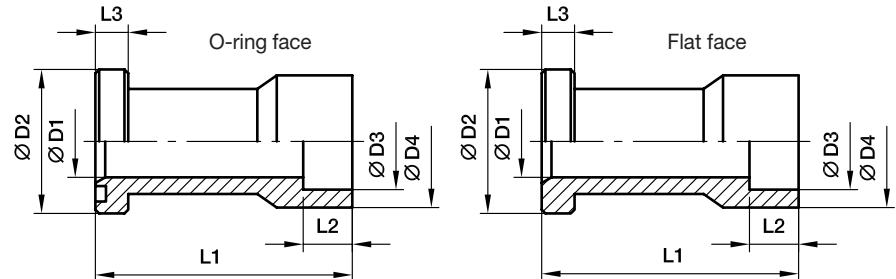

3000 PSI Series

Nom. flange size		max.	D1	D2	D3	D4	L1	L2	L3	Weight (steel) kg/piece	O-ring face Order code*	Flat face Order code*	PN (bar) ¹⁾	
SAE (in)	ISO (DN)												S	SS
1/2	13	20.0	15	30.2	20.5	30	60	13	6.7	0.45	ESL32/20.5	ESLG32/20.5	345	345
1/2	13	21.3	15	30.2	21.7	30	60	13	6.7	0.44	ESL32/21.7	ESLG32/21.7	345	345
3/4	19	25.0	19	38.1	25.5	35	68	13	6.7	0.60	ESL33/25.5	ESLG33/25.5	345	345
3/4	19	26.9	19	38.1	27.3	35	68	13	6.7	0.58	ESL33/27.3	ESLG33/27.3	345	345
1	25	30.0	23	44.4	30.5	44	75	16	8.0	0.75	ESL34/30.5	ESLG34/30.5	345	345
1	25	32.0	24	44.4	32.5	44	75	16	8.0	0.72	ESL34/32.5	ESLG34/32.5	345	345
1	25	33.7	25	44.4	34.0	44	75	16	8.0	0.70	ESL34/34	ESLG34/34	345	345
1	25	35.0	25	44.4	35.5	44	75	16	8.0	0.68	ESL34/35.5	ESLG34/35.5	345	345
1 1/4	32	38.0	32	50.8	38.5	55	95	18	8.0	0.87	ESL35/38.5	ESLG35/38.5	276	276
1 1/4	32	40.0	32	50.8	40.5	55	95	18	8.0	0.95	ESL35/40.5	ESLG35/40.5	276	276
1 1/4	32	42.4	32	50.8	43.0	55	95	18	8.0	0.93	ESL35/43	ESLG35/43	276	276
1 1/2	38	48.3	38	60.3	49.0	68	100	20	8.0	1.54	ESL36/49	ESLG36/49	207	207
1 1/2	38	50.0	38	60.3	50.4	68	100	20	8.0	1.50	ESL36/50.4	ESLG36/50.4	207	207
2	51	60.3	50	71.4	61.0	79	107	22	9.5	1.89	ESL38/61	ESLG38/61	207	207
2	51	65.0	50	71.4	65.8	79	107	22	9.5	1.80	ESL38/65.8	ESLG38/65.8	207	207
2 1/2	64	73.0	58	84.1	74.0	98	130	24	9.5	2.30	ESL310/74	ESLG310/74	172	172
2 1/2	64	76.1	58	84.1	77.0	98	130	24	9.5	2.25	ESL310/77	ESLG310/77	172	172
2 1/2	64	80.0	58	84.1	81.0	98	130	24	9.5	2.15	ESL310/81	ESLG310/81	172	172
3	76	88.9	70	101.6	90.5	116	150	28	9.5	3.00	ESL312/90.5	ESLG312/90.5	138	138

6000 PSI Series

1/2	13	20.0	15	31.8	20.5	32	60	13	7.7	0.45	ESL62/20.5	ESLG62/20.5	420	420
1/2	13	21.3	15	31.8	21.7	32	60	13	7.7	0.44	ESL62/21.7	ESLG62/21.7	420	420
1/2	13	22.0	15	31.8	22.5	32	60	13	7.7	0.65	ESL62/22.5	ESLG62/22.5	420	420
3/4	19	25.0	19	41.3	25.7	40	68	13	8.7	0.63	ESL63/25.7	ESLG63/25.7	420	420
3/4	19	26.9	19	41.3	27.3	40	68	13	8.7	0.61	ESL63/27.3	ESLG63/27.3	420	420
3/4	19	28.0	19	41.3	28.7	40	68	13	8.7	0.60	ESL63/28.7	ESLG63/28.7	420	420
1	25	33.7	25	47.6	34.0	48	75	16	9.5	0.75	ESL64/34	ESLG64/34	420	420
1	25	35.0	25	47.6	35.5	48	75	16	9.5	0.73	ESL64/35.5	ESLG64/35.5	420	420

1) Pressure shown = Item deliverable

$$\frac{PN \text{ (bar)}}{10} = PN \text{ (MPa)}$$

The pressures given here are the maximum allowable for the flange fittings. If the pipe or tube used has a lower pressure rating, then the welded assembly rating will be the lower one, assuming the weld is adequately strong.

*Please add the suffixes below according to the material / surface required.

Order code suffixes					
Material	Suffix surface and material	Example only flange adapter	Example incl. splitflanges, metr. screws and O-ring	Example incl. splitflanges, UNC screws and O-ring	Standard sealing material (no additional suffix needed)
Steel, blanc oil dipped	S	ESL32/20.5S	ESL32/20.5SM	ESL32/20.5SU	NBR
Stainless steel	SS	ESL32/20.5SS	ESL32/20.5SSM	ESL32/20.5SSU	VIT

PFF-G SAE Straight 4 bolt flange with BSPP thread

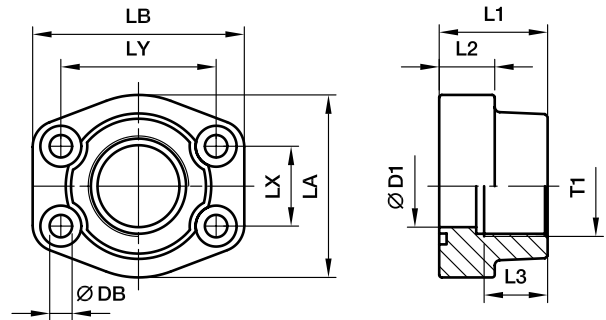
 SAE Flange / Female BSPP thread
 (ISO 6162-1/-2) (ISO 1179-1)

3000 PSI Series

Nom. flange size		T1	D1	L1	L2	L3	LA	LB	LX	LY	DB	Screws			Weight (steel) kg/piece	Order code*	PN (bar) ¹⁾	
SAE (in)	ISO (DN)											(metr.)	(unc.)	S			SS	
1/2	13	G3/8	13	36	16	13	46	58	17.5	38.1	9.0	M 8 30	5/16 1 1/4	0.25	PFF32G38	345	345	
1/2	13	G1/2	13	36	16	15	46	58	17.5	38.1	9.0	M 8 30	5/16 1 1/4	0.28	PFF32G	345	345	
3/4	19	G3/4	19	36	18	18	49	66	22.3	47.6	10.5	M10 35	3/8 1 1/2	0.39	PFF33G	345	345	
1	25	G1	25	38	18	20	53	71	26.2	52.4	10.5	M10 35	3/8 1 1/2	0.46	PFF34G	345	345	
1 1/4	32	G1 1/4	31	41	21	22	69	80	30.2	58.7	10.5	M10 40	7/16 1 1/2	0.66	PFF35G	276	276	
1 1/2	38	G1 1/2	38	44	25	24	77	94	35.7	69.9	13.5	M12 45	1/2 1 3/4	1.05	PFF36G	207	207	
2	51	G2	50	45	25	26	89	103	42.9	77.8	13.5	M12 45	1/2 1 3/4	1.19	PFF38G	207	207	
2 1/2	64	G2 1/2	63	50	25	30	101	115	50.8	88.9	13.5	M12 45	1/2 1 3/4	1.40	PFF310G	172	172	
3	76	G3	73	50	27	30	124	135	61.9	106.4	17.0	M16 50	5/8 2	2.15	PFF312G	138	138	
3 1/2	89	G3 1/2	89	50	27	30	136	152	61.9	120.7	17.0	M16 50	5/8 2	2.40	PFF314G	34	34	
4	102	G4	99	50	27	30	146	162	77.8	130.2	17.0	M16 50	5/8 2	2.85	PFF316G	34	34	
5	127	G5	120	50	28	30	180	184	92.1	152.4	17.0	M16 50	5/8 2	3.25	PFF320G	34	34	

6000 PSI Series

1/2	13	G3/8	13	36	16	13	46	58	18.2	40.5	9.0	M 8 30	5/16 1 1/4	0.26	PFF62G38	420	420
1/2	13	G1/2	13	36	16	15	46	58	18.2	40.5	9.0	M 8 30	5/16 1 1/4	0.29	PFF62G	420	420
3/4	19	G3/4	19	36	19	18	53	71	23.8	50.8	10.5	M10 35	3/8 1 1/2	0.50	PFF63G	420	420
1	25	G1	25	44	24	20	69	80	27.8	57.2	10.5	M12 45	1/2 1 3/4	0.76	PFF64G	420	420
1 1/4	32	G1 1/4	31	44	27	22	77	94	31.8	66.6	15.0	M14 45	1/2 1 3/4	1.20	PFF65G	420	420
1 1/2	38	G1 1/2	38	51	30	24	89	106	36.5	79.3	17.0	M16 50	5/8 2	1.65	PFF66G	420	420
2	51	G2	50	70	37	33	116	135	44.5	96.8	21.0	M20 65	3/4 2 1/2	2.45	PFF68G	420	420
2 1/2	64	G2 1/2	63	75	45	35	150	166	58.7	123.8	25.0	M24 85	-	3.05	PFF610G	420	420
3	76	G3	73	90	55	40	178	208	71.4	152.4	32.0	M30 110	-	3.45	PFF612G	420	420

1) Pressure shown = Item deliverable

$$\frac{PN \text{ (bar)}}{10} = PN \text{ (MPa)}$$

*Please add the suffixes below according to the material / surface required.

Order code suffixes					
Material	Suffix surface and material	Example only 4 bolt flange	Example 4 bolt flange incl. metr. screws and O-ring	Example 4 bolt flange incl. UNC screws and O-ring	Standard sealing material (no additional suffix needed)
Steel, blanc oil dipped	S	PFF32G38S	PFF32G38SM	PFF32G38SU	
Stainless steel	SS	PFF32G38SS	PFF32G38SSM	PFF32G38SSU	VIT

PCFF-G SAE Straight 4 bolt flange with BSPP thread

SAE Counter flange / Female BSPP thread
(ISO 6162-1/-2) (ISO 1179-1)

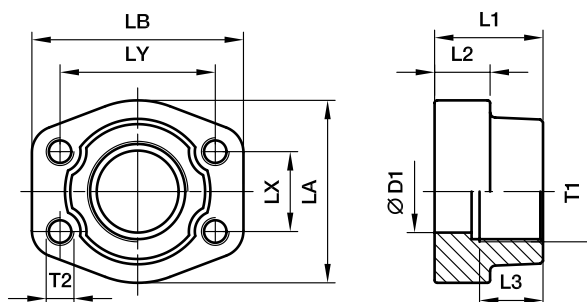

3000 PSI Series

Nom. flange size		T1	D1	L1	L2	L3	LA	LB	LX	LY	T2		Weight (steel) kg/piece	Order code*	PN (bar) ¹⁾	
SAE (in)	ISO (DN)										(metr.)	(unc.)			S	SS
1/2	13	G3/8	13	36	16	19	46	58	17.5	38.1	M 8	5/16	0.25	PCFF32G38	345	345
1/2	13	G1/2	13	36	16	19	46	58	17.5	38.1	M 8	5/16	0.28	PCFF32G	345	345
3/4	19	G3/4	19	36	18	19	49	66	22.3	47.6	M10	3/8	0.39	PCFF33G	345	345
1	25	G1	25	38	18	19	53	71	26.2	52.4	M10	3/8	0.46	PCFF34G	345	345
1 1/4	32	G1 1/4	31	41	21	22	69	80	30.2	58.7	M10	7/16	0.66	PCFF35G	276	276
1 1/2	38	G1 1/2	38	44	25	24	77	94	35.7	69.9	M12	1/2	1.05	PCFF36G	207	207
2	51	G2	50	45	25	26	89	103	42.9	77.8	M12	1/2	1.19	PCFF38G	207	207
2 1/2	64	G2 1/2	63	50	25	30	101	115	50.8	88.9	M12	1/2	1.40	PCFF310G	172	172
3	76	G3	73	50	27	30	124	135	61.9	106.4	M16	5/8	2.15	PCFF312G	138	138
3 1/2	89	G3 1/2	89	50	27	30	136	152	69.9	120.7	M16	5/8	2.40	PCFF314G	34	34
4	102	G4	99	50	27	30	146	162	77.8	130.2	M16	5/8	2.85	PCFF316G	34	34
5	127	G5	120	50	28	30	180	184	92.1	152.4	M16	5/8	3.25	PCFF320G	34	34

6000 PSI Series

1/2	13	G3/8	13	36	16	19	46	58	18.2	40.5	M 8	5/16	0.26	PCFF62G38	420	420
1/2	13	G1/2	13	36	16	19	46	58	18.2	40.5	M 8	5/16	0.29	PCFF62G	420	420
3/4	19	G3/4	19	36	19	22	53	71	23.8	50.8	M10	3/8	0.50	PCFF63G	420	420
1	25	G1	25	44	24	24	69	80	27.8	57.2	M12	7/16	0.76	PCFF64G	420	420
1 1/4	32	G1 1/4	31	44	27	25	77	94	31.8	66.6	M14	1/2	1.20	PCFF65G	420	420
1 1/2	38	G1 1/2	38	51	30	28	89	106	36.5	79.3	M16	5/8	1.65	PCFF66G	420	420
2	51	G2	50	70	37	33	116	135	44.5	96.8	M20	3/4	2.45	PCFF68G	420	420
2 1/2	64	G2 1/2	63	75	45	35	150	166	58.7	123.8	M24	-	3.05	PCFF610G	420	420
3	76	G3	73	90	55	40	178	208	71.4	152.4	M30	-	3.45	PCFF612G	420	420

¹⁾ Pressure shown = Item deliverable

$$\frac{PN \text{ (bar)}}{10} = PN \text{ (MPa)}$$

*Please add the suffixes below according to the material / surface required.

Order code suffixes				
Material	Suffix surface and material	Example 4 bolt flange with metr. threads	Example 4 bolt flange with UNC threads	Standard sealing material (no additional suffix needed)
Steel, blanc oil dipped	S	PCFF32G38SM	PCFF32G38SU	NBR
Stainless steel	SS	PCFF32G38SSM	PCFF32G38SSU	VIT

PAFSF-G SAE Straight 4 bolt flange flat with BSPP thread

 SAE Flange / Female BSPP thread
 (ISO 6162-1/-2) (ISO 1179-1)

only for low pressure applications

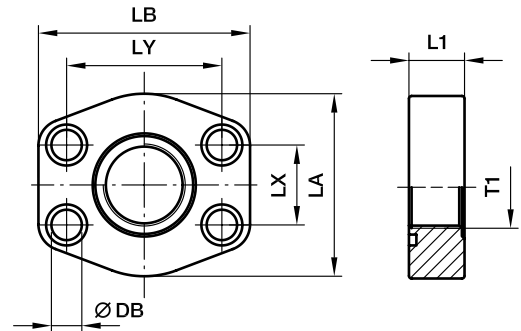
3000 PSI Series

Nom. flange size		T1	L1	LA	LB	LX	LY	DB	Screws		Weight (steel) kg/piece	Order code*	PN (bar) ¹⁾	
SAE (in)	ISO (DN)								(metr.)	(unc.)			S	SS
1/2	13	G3/8	16	46	58	17.5	38.1	9.0	M 8 30	5/16 1 1/4	0.20	PAFSF080G38	40	40
1/2	13	G1/2	16	46	58	17.5	38.1	9.0	M 8 30	5/16 1 1/4	0.27	PAFSF080G	40	40
3/4	19	G1/2	18	49	66	22.3	47.6	10.5	M10 35	3/8 1 1/2	0.29	PAFSF100G12	40	40
3/4	19	G3/4	18	49	66	22.3	47.6	10.5	M10 35	3/8 1 1/2	0.27	PAFSF100G	40	40
1	25	G3/4	19	53	71	26.2	52.4	10.5	M10 35	3/8 1 1/2	0.32	PAFSF102G34	40	40
1	25	G1	19	53	71	26.2	52.4	10.5	M10 35	3/8 1 1/2	0.31	PAFSF102G	40	40
1 1/4	32	G1	21	69	80	30.2	58.7	10.5	M10 35	7/16 1 1/2	0.44	PAFSF104G1	40	40
1 1/4	32	G1 1/4	21	69	80	30.2	58.7	10.5	M10 35	7/16 1 1/2	0.56	PAFSF104G	40	40
1 1/2	38	G1 1/4	24	77	95	35.7	69.9	13.5	M12 45	1/2 1 3/4	0.83	PAFSF106G114	40	40
1 1/2	38	G1 1/2	24	77	95	35.7	69.9	13.5	M12 45	1/2 1 3/4	0.76	PAFSF106G	40	40
2	51	G1 1/2	24	89	103	42.9	77.8	13.5	M12 45	1/2 1 3/4	1.00	PAFSF108G112	40	40
2	51	G2	24	89	103	42.9	77.8	13.5	M12 45	1/2 1 3/4	0.90	PAFSF108G	40	40
2 1/2	64	G2	25	101	116	50.8	88.9	13.5	M12 45	1/2 1 3/4	1.30	PAFSF110G2	40	40
2 1/2	64	G2 1/2	25	101	116	50.8	88.9	13.5	M12 45	1/2 1 3/4	1.25	PAFSF110G	40	40
3	76	G2 1/2	25	124	136	61.9	106.4	17.0	M16 50	5/8 2	1.86	PAFSF112G212	30	30
3	76	G3	25	124	136	61.9	106.4	17.0	M16 50	5/8 2	1.49	PAFSF112G	30	30
3 1/2	89	G3	25	136	152	69.9	120.7	17.0	M16 50	5/8 2	1.68	PAFSF114G3	30	30
3 1/2	89	G3 1/2	25	136	152	69.9	120.7	17.0	M16 50	5/8 2	1.59	PAFSF114G	30	30
4	102	G3 1/2	25	146	162	77.8	130.2	17.0	M16 50	5/8 2	2.35	PAFSF116G312	30	30
4	102	G4	25	146	162	77.8	130.2	17.0	M16 50	5/8 2	2.25	PAFSF116G	30	30
5	127	G4	25	180	184	92.1	152.4	17.0	M16 50	5/8 2	3.45	PAFSF118G4	30	30
5	127	G5	25	180	184	92.1	152.4	17.0	M16 50	5/8 2	3.15	PAFSF118G	30	30

6000 PSI Series

1/2	13	G3/8	16	46	58	18.2	40.5	9.0	M 8 30	5/16 1 1/4	0.25	PAFSF401G38	40	40
1/2	13	G1/2	16	46	58	18.2	40.5	9.0	M 8 30	5/16 1 1/4	0.20	PAFSF401G	40	40
3/4	19	G1/2	19	53	71	23.8	50.8	10.5	M10 35	3/8 1 1/2	0.37	PAFSF402G12	40	40
3/4	19	G3/4	19	53	71	23.8	50.8	10.5	M10 35	3/8 1 1/2	0.36	PAFSF402G	40	40
1	25	G3/4	24	66	80	27.8	57.2	13.5	M12 45	7/16 1 1/2	0.64	PAFSF403G34	40	40
1	25	G1	24	66	80	27.8	57.2	13.5	M12 45	7/16 1 1/2	0.60	PAFSF403G	40	40
1 1/4	32	G1	27	77	94	31.8	66.6	15.0	M14 50	1/2 1 3/4	0.88	PAFSF404G1	40	40
1 1/4	32	G1 1/4	27	77	94	31.8	66.6	15.0	M14 50	1/2 1 3/4	0.87	PAFSF404G	40	40
1 1/2	38	G1 1/4	30	89	103	36.5	79.3	17.0	M16 55	5/8 2	1.14	PAFSF405G114	40	40
1 1/2	38	G1 1/2	30	89	103	36.5	79.3	17.0	M16 55	5/8 2	1.01	PAFSF405G	40	40
2	51	G1 1/2	35	123	135	44.5	96.8	21.0	M20 65	3/4 2 1/2	2.94	PAFSF406G112	40	40
2	51	G2	35	123	135	44.5	96.8	21.0	M20 65	3/4 2 1/2	2.84	PAFSF406G	40	40

*Please add the suffixes below according to the material / surface required.

Order code suffixes					
Material	Suffix surface and material	Example only 4 bolt flange	Example 4 bolt flange incl. metr. screws and O-ring	Example 4 bolt flange incl. UNC screws and O-ring	Standard sealing material (no additional suffix needed)
Steel, blanc oil dipped	S	PAFSF080GS	PAFSF080GSM	PAFSF080GSU	NBR
Stainless steel	SS	PAFSF080GSS	PAFSF080GSSM	PAFSF080GSSU	VIT

1) Pressure shown = Item deliverable

$$\frac{\text{PN (bar)}}{10} = \text{PN (MPa)}$$

PEFF-G SAE 90° 4 bolt flange with BSPP thread

SAE 90° Flange / Female BSPP thread
(ISO 6162-1/-2) (ISO 1179-1)

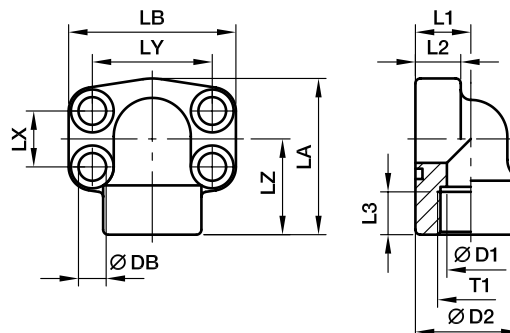

3000 PSI Series

Nom. flange size		T1	D1	D2	L1	L2	L3	LA	LB	LX	LY	LZ	DB	Screws		Weight (steel) kg/piece	Order code*	PN (bar) ¹⁾	
SAE (in)	ISO (DN)													(metr.)	(unc.)			S	SS
1/2	13	G1/2	13	34.0	18	16	16	59	57	17.5	38.1	36	9.0	M 8 30	5/16 1 1/4	0.35	PEFF32G	348	348
3/4	19	G3/4	19	38.5	22	18	19	63	68	22.3	47.6	38	10.5	M10 35	3/8 1 1/2	0.55	PEFF33G	348	348
1	25	G1	25	44.5	28	19	19	68	74	26.2	52.4	41	10.5	M10 35	3/8 1 1/2	0.80	PEFF34G	348	348
1 1/4	32	G1 1/4	31	53.5	30	22	22	84	81	30.2	58.7	50	10.5	M10 35	7/16 1 1/2	1.30	PEFF35G	278	278
1 1/2	38	G1 1/2	38	62.5	36	25	24	97	95	35.7	69.9	58	13.5	M12 45	1/2 1 3/4	1.60	PEFF36G	210	210
2	51	G2	50	77.0	41	25	26	109	105	42.9	77.8	65	13.5	M12 45	1/2 1 3/4	2.00	PEFF38G	210	210
2 1/2	64	G2 1/2	60	89.0	50	25	30	127	115	50.8	88.9	77	13.5	M12 45	1/2 1 3/4	2.40	PEFF310G	175	175

6000 PSI Series

1/2	13	G1/2	13	34.0	18	16	16	59	57	18.2	40.5	36	8.8	M 8 30	5/16 1 1/4	0.35	PEFF62G	420	420
3/4	19	G3/4	19	44.5	28	20	22	68	72	23.8	50.8	41	10.5	M10 35	3/8 1 1/2	0.80	PEFF63G	420	420
1	25	G1	25	53.5	30	24	24	84	82	27.8	57.2	50	13.5	M12 45	7/16 1 1/2	1.30	PEFF64G	420	420
1 1/4	32	G1 1/4	31	62.5	36	25	25	97	95	31.8	66.6	58	15.0**	M14 45	1/2 1 3/4	1.60	PEFF65G	420	420
1 1/2	38	G1 1/2	38	77.0	51	26	28	109	110	36.5	79.3	65	17.0	M16 50	5/8 2	2.00	PEFF66G	420	420
2	51	G2	50	87.0	45	35	34	133	134	44.5	96.8	75	21.0	M20 65	3/4 2 1/2	2.50	PEFF68G	420	420

**DB = 13.5 for UNC Screws

¹⁾ Pressure shown = Item deliverable

$$\frac{\text{PN (bar)}}{10} = \text{PN (MPa)}$$

*Please add the suffixes below according to the material / surface required.

Order code suffixes					
Material	Suffix surface and material	Example only 4 bolt flange	Example 4 bolt flange incl. metr. screws and O-ring	Example 4 bolt flange incl. UNC screws and O-ring	Standard sealing material (no additional suffix needed)
Steel, blanc oil dipped	S	PEFF32GS	PEFF32GSM	PEFF32GSU	NBR
Stainless steel	SS	PEFF32GSS	PEFF32GSSM	PEFF32GSSU	VIT

PFF-N SAE Straight 4 bolt flange with NPT thread

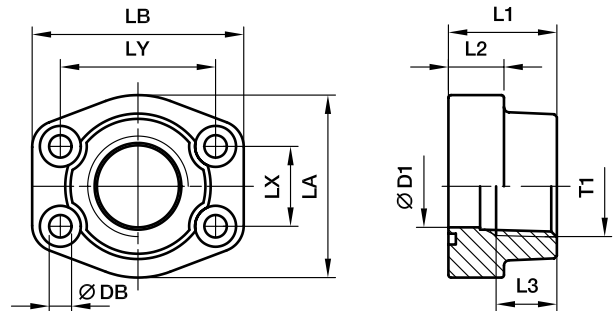
 SAE Flange / Female NPT thread
 (ISO 6162-1/-2) (SAE 476)

3000 PSI Series

Nom. flange size		T1	D1	L1	L2	L3	LA	LB	LX	LY	DB	Screws		Weight (steel) kg/piece	Order code*	PN (bar) ¹⁾	
SAE (in)	ISO (DN)											(metr.)	(unc.)			S	SS
1/2	13	3/8NPT	13	36	16	15	46	58	17.5	38.1	9.0	M 8 30	5/16 1 1/4	0.25	PFF32N38	345	345
1/2	13	1/2NPT	13	36	16	15	46	58	17.5	38.1	9.0	M 8 30	5/16 1 1/4	0.28	PFF32N	345	345
3/4	19	3/4NPT	19	36	18	19	49	66	22.3	47.6	10.5	M10 35	3/8 1 1/2	0.39	PFF33N	345	345
1	25	1NPT	25	38	18	19	53	71	26.2	52.4	10.5	M10 35	3/8 1 1/2	0.46	PFF34N	345	345
1 1/4	32	1 1/4NPT	31	41	21	22	69	80	30.2	58.7	10.5	M10 40	7/16 1 1/2	0.66	PFF35N	276	276
1 1/2	38	1 1/2NPT	38	44	25	24	77	94	35.7	69.9	13.5	M12 45	1/2 1 3/4	1.05	PFF36N	207	207
2	51	2NPT	50	45	25	26	89	103	42.9	77.8	13.5	M12 45	1/2 1 3/4	1.19	PFF38N	207	207
2 1/2	64	2 1/2NPT	63	50	25	30	101	115	50.8	88.9	13.5	M12 45	1/2 1 3/4	1.40	PFF310N	172	172
3	76	3NPT	73	50	27	34	124	135	61.9	106.4	17.0	M16 50	5/8 2	2.15	PFF312N	138	138
3 1/2	89	3 1/2NPT	89	50	27	36	136	152	69.9	120.7	17.0	M16 50	5/8 2	2.40	PFF314N	34	34
4	102	4NPT	99	50	27	36	146	162	77.8	130.2	17.0	M16 50	5/8 2	2.85	PFF316N	34	34
5	127	5NPT	120	50	28	36	180	184	92.1	152.4	17.0	M16 50	5/8 2	3.25	PFF320N	34	34

6000 PSI Series

1/2	13	3/8NPT	13	36	16	15	46	58	18.2	40.5	9.0	M 8 30	5/16 1 1/4	0.26	PFF62N38	420	420
1/2	13	1/2NPT	13	36	16	15	46	58	18.2	40.5	9.0	M 8 30	5/16 1 1/4	0.29	PFF62N	420	420
3/4	19	3/4NPT	19	36	19	22	53	71	23.8	50.8	10.5	M10 35	3/8 1 1/2	0.50	PFF63N	420	420
1	25	1NPT	25	44	24	24	69	80	27.8	57.2	13.5	M12 45	1/2 1 3/4	0.76	PFF64N	420	420
1 1/4	32	1 1/4NPT	31	44	27	25	77	94	31.8	66.6	15.0	M14 45	1/2 1 3/4	1.20	PFF65N	420	420
1 1/2	38	1 1/2NPT	38	51	30	28	89	106	36.5	79.3	17.0	M16 50	5/8 2	1.65	PFF66N	420	420
2	51	2NPT	50	70	37	33	116	135	44.5	96.8	21.0	M20 65	3/4 2 1/2	2.45	PFF68N	420	420
2 1/2	64	2 1/2NPT	63	75	45	35	150	166	58.7	123.8	25.0	M24 85	-	3.05	PFF610N	420	420
3	76	3NPT	73	90	55	40	178	208	71.4	152.4	32.0	M30 110	-	3.45	PFF612N	420	420

1) Pressure shown = Item deliverable

$$\frac{\text{PN (bar)}}{10} = \text{PN (MPa)}$$

*Please add the suffixes below according to the material / surface required.

Order code suffixes					
Material	Suffix surface and material	Example only 4 bolt flange	Example 4 bolt flange incl. metr. screws and O-ring	Example 4 bolt flange incl. UNC screws and O-ring	Standard sealing material (no additional suffix needed)
Steel, blanc oil dipped	S	PFF32N38S	PFF32N38SM	PFF32N38SU	NBR
Stainless steel	SS	PFF32N38SS	PFF32N38SSM	PFF32N38SSU	VIT

PCFF-N SAE Straight 4 bolt flange with NPT thread

SAE Counter flange / Female NPT thread
(ISO 6162-1/-2) (SAE 476)

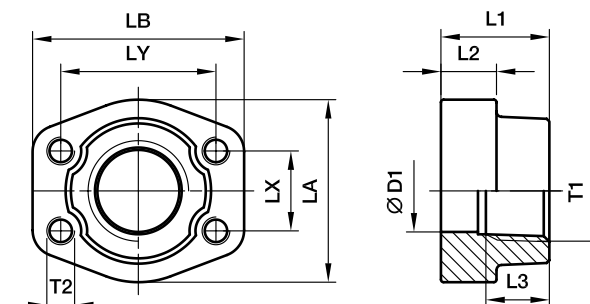

3000 PSI Series

Nom. flange size		T1	D1	L1	L2	L3	LA	LB	LX	LY	T2		Weight (steel) kg/piece	Order code*	PN (bar) ¹⁾	
SAE (in)	ISO (DN)										(metr.)	(unc.)			S	SS
1/2	13	3/8NPT	13	36	16	19	47	57	17.5	38.1	M 8	5/16	0.25	PCFF32N38	345	345
1/2	13	1/2NPT	13	36	16	19	47	57	17.5	38.1	M 8	5/16	0.28	PCFF32N	345	345
3/4	19	3/4NPT	19	36	18	19	49	66	22.3	47.6	M10	3/8	0.39	PCFF33N	345	345
1	25	1NPT	25	38	18	19	53	71	26.2	52.4	M10	3/8	0.46	PCFF34N	345	345
1 1/4	32	1 1/4NPT	31	41	21	22	69	80	30.2	58.7	M10	7/16	0.66	PCFF35N	276	276
1 1/2		1 1/2NPT	38	44	25	24	77	94	35.7	69.9	M12	1/2	1.05	PCFF36N	207	207
2	51	2NPT	50	45	25	26	89	103	42.9	77.8	M12	1/2	1.19	PCFF38N	207	207
2 1/2	64	2 1/2NPT	63	50	25	30	101	115	50.8	88.9	M12	1/2	1.40	PCFF310N	172	172
3	76	3NPT	73	50	27	30	124	135	61.9	106.4	M16	5/8	2.15	PCFF312N	138	138
3 1/2	89	3 1/2NPT	89	50	27	30	136	152	69.9	120.7	M16	5/8	2.40	PCFF314N	34	34
4	102	4NPT	99	50	27	30	146	162	77.8	130.2	M16	5/8	2.85	PCFF316N	34	34
5	127	5NPT	120	50	28	30	180	184	92.1	152.4	M16	5/8	3.25	PCFF320N	34	34

6000 PSI Series

1/2	13	3/8NPT	13	36	16	19	47	57	18.2	40.5	M 8	5/16	0.26	PCFF62N38	420	420
1/2	13	1/2NPT	13	36	16	19	47	57	18.2	40.5	M 8	5/16	0.29	PCFF62N	420	420
3/4	19	3/4NPT	19	36	19	22	53	71	23.8	50.8	M10	3/8	0.50	PCFF63N	420	420
1	25	1NPT	25	44	24	24	69	80	27.8	57.2	M12	7/16	0.76	PCFF64N	420	420
1 1/4	32	1 1/4NPT	31	44	27	25	77	94	31.8	66.6	M14	1/2	1.20	PCFF65N	420	420
1 1/2	32	1 1/2NPT	38	51	30	28	89	106	36.5	79.3	M16	5/8	1.65	PCFF66N	420	420
2	51	2NPT	50	70	37	33	116	135	44.5	96.8	M20	3/4	2.45	PCFF68N	420	420
2 1/2	64	2 1/2NPT	63	75	45	35	150	166	58.7	123.8	M24	-	3.05	PCFF610N	420	420
3	76	3NPT	73	90	55	40	178	208	71.4	152.4	M30	-	3.45	PCFF612N	420	420

¹⁾ Pressure shown = Item deliverable

$$\frac{PN \text{ (bar)}}{10} = PN \text{ (MPa)}$$

*Please add the suffixes below according to the material / surface required.

Order code suffixes				
Material	Suffix surface and material	Example 4 bolt flange with metr. threads	Example 4 bolt flange with UNC threads	Standard sealing material (no additional suffix needed)
Steel, blanc oil dipped	S	PCFF32N38SM	PCFF32N38SU	NBR
Stainless steel	SS	PCFF32N38SSM	PCFF32N38SSU	VIT

PEFF-N SAE 90° 4 bolt flange with NPT thread

SAE 90° Flange / Female NPT thread
(ISO 6162-1/-2) (SAE 476)

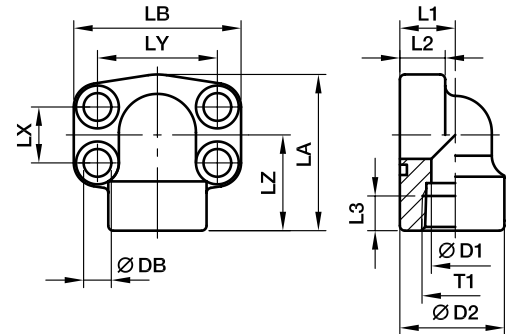

3000 PSI Series

Nom. flange size		T1	D1	D2	L1	L2	L3	LA	LB	LX	LY	LZ	DB	Screws		Weight (steel) kg/piece	Order code*	PN (bar) ¹⁾	
SAE (in)	ISO (DN)													(metr.)	(unc.)			S	SS
1/2	13	1/2NPT	13	34.0	18	16	16	59	56	17.5	38.1	36	9.0	M 8 30	5/16 1 1/4	0.35	PEFF32N	348	348
3/4	19	3/4NPT	19	38.5	22	18	19	63	68	22.3	47.6	38	10.5	M10 35	3/8 1 1/2	0.55	PEFF33N	348	348
1	25	1NPT	25	44.5	28	19	19	68	74	26.2	52.4	41	10.5	M10 35	3/8 1 1/2	0.80	PEFF34N	348	348
1 1/4	32	1 1/4NPT	31	53.5	30	22	22	84	81	30.2	58.7	50	10.5	M10 35	7/16 1 1/2	1.30	PEFF35N	278	278
1 1/2	38	1 1/2NPT	38	62.5	36	25	24	97	95	35.7	69.9	58	13.5	M12 45	1/2 1 3/4	1.60	PEFF36N	210	210
2	51	2NPT	50	77.0	41	25	26	109	105	42.9	77.8	65	13.5	M12 45	1/2 1 3/4	2.00	PEFF38N	210	210
2 1/2	64	2 1/2NPT	60	89.0	50	25	30	127	115	50.8	88.9	77	13.5	M12 45	1/2 1 3/4	2.40	PEFF310N	175	175

6000 PSI Series

1/2	13	1/2NPT	13	34.0	18	16	16	59	56	18.2	40.5	36	9.0	M 8 30	5/16 1 1/4	0.35	PEFF62N	420	420
3/4	19	3/4NPT	19	44.5	28	20	22	68	72	23.8	50.8	41	10.5	M10 35	3/8 1 1/2	0.80	PEFF63N	420	420
1	25	1NPT	25	53.5	30	24	24	84	82	27.8	57.2	50	13.5	M12 45	7/16 1 1/2	1.30	PEFF64N	420	420
1 1/4	32	1 1/4NPT	31	62.5	36	25	25	97	95	31.8	66.6	58	15.0**	M14 45	1/2 1 3/4	1.60	PEFF65N	420	420
1 1/2	38	1 1/2NPT	38	77.0	51	26	28	109	110	36.5	79.3	65	17.0	M16 50	5/8 2	2.00	PEFF66N	420	420
2	51	2NPT	50	87.0	45	35	34	133	134	44.5	96.8	75	21.0	M20 65	3/4 2 1/2	2.50	PEFF68N	420	420

**DB = 13.5 for UNC Screws

¹⁾ Pressure shown = Item deliverable

$$\frac{PN \text{ (bar)}}{10} = PN \text{ (MPa)}$$

*Please add the suffixes below according to the material / surface required.

Order code suffixes					
Material	Suffix surface and material	Example only 4 bolt flange	Example 4 bolt flange incl. metr. screws and O-ring	Example 4 bolt flange incl. UNC screws and O-ring	Standard sealing material (no additional suffix needed)
Steel, blanc oil dipped	S	PEFF32NS	PEFF32NSM	PEFF32NSU	NBR
Stainless steel	SS	PEFF32NSS	PEFF32NSSM	PEFF32NSSU	VIT



PAFS-M SAE Straight 4 bolt flange with metric thread

SAE Flange / Female metric thread for O-ring
(ISO 6162-1/-2) (ISO 6149-1)

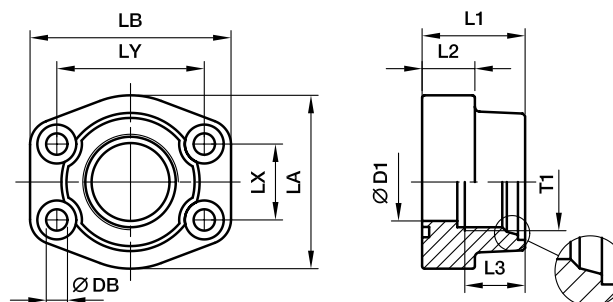

3000 PSI Series

Nom. flange size		T1	D1	L1	L2	L3	LA	LB	LX	LY	DB	Screws		Weight (steel) kg/piece	Order code*	PN (bar) ¹⁾	
SAE (in)	ISO (DN)											(metr.)	(unc.)			S	SS
1/2	13	M18 1.5	13	36	16	15	46	58	17.5	38.1	9.0	M 8 30	5/16 1 1/4	0.33	PAFS080MA	345	345
1/2	13	M20 1.5	13	36	16	15	46	58	17.5	38.1	9.0	M 8 30	5/16 1 1/4	0.30	PAFS080MB	345	345
3/4	19	M22 1.5	19	36	18	16	49	66	22.3	47.6	10.5	M10 35	3/8 1 1/2	0.45	PAFS100MA	345	345
3/4	19	M27 2.0	19	36	18	19	49	66	22.3	47.6	10.5	M10 35	3/8 1 1/2	0.42	PAFS100MB	345	345
1	25	M27 2.0	25	38	18	19	53	71	26.2	52.4	10.5	M10 40	7/16 1 1/2	0.48	PAFS102MA	276	276
1	25	M33 2.0	25	38	18	19	53	71	26.2	52.4	13.5	M12 45	1/2 1 3/4	0.45	PAFS102MB	207	207
1 1/4	32	M33 2.0	31	41	21	19	69	80	30.2	58.7	13.5	M12 45	1/2 1 3/4	0.84	PAFS104MA	207	207
1 1/4	32	M42 2.0	31	41	21	20	69	80	30.2	58.7	13.5	M12 45	1/2 1 3/4	0.71	PAFS104MB	172	172
1 1/2	38	M42 2.0	38	44	25	20	77	94	35.7	69.9	17.0	M16 50	5/8 2	1.25	PAFS106MA	138	138
1 1/2	38	M48 2.0	38	44	25	22	77	94	35.7	69.9	17.0	M16 50	5/8 2	1.14	PAFS106MB	34	34

6000 PSI Series

1/2	13	M18 1.5	13	36	16	15	46	58	18.2	40.5	9.0	M 8 30	5/16 1 1/4	0.33	PAFS401MA	420	420
1/2	13	M20 1.5	13	36	16	15	46	58	18.2	40.5	9.0	M 8 30	5/16 1 1/4	0.30	PAFS401MB	420	420
3/4	19	M22 1.5	19	36	19	16	53	71	23.8	50.8	10.5	M10 35	3/8 1 1/2	0.53	PAFS402MA	420	420
3/4	19	M27 2.0	19	36	19	19	53	71	23.8	50.8	10.5	M10 35	3/8 1 1/2	0.50	PAFS402MB	420	420
1	25	M27 2.0	25	44	24	19	69	80	27.8	57.2	13.5	M12 45	7/16 1 1/2	0.86	PAFS403MA	420	420
1	25	M33 2.0	25	44	24	19	69	80	27.8	57.2	13.5	M12 45	7/16 1 1/2	0.84	PAFS403MB	420	420
1 1/4	32	M33 2.0	31	44	27	19	77	94	31.8	66.6	15.0	M14 45	1/2 1 3/4	1.30	PAFS404MA	420	420
1 1/4	32	M42 2.0	31	44	27	20	77	94	31.8	66.6	15.0	M14 45	1/2 1 3/4	1.25	PAFS404MB	420	420
1 1/2	38	M42 2.0	38	51	30	20	89	106	36.5	79.3	17.0	M16 50	5/8 2	1.78	PAFS405MA	420	420
1 1/2	38	M48 2.0	38	51	30	22	89	106	36.5	79.3	17.0	M16 50	5/8 2	1.70	PAFS405MB	420	420

¹⁾ Pressure shown = Item deliverable

$$\frac{\text{PN (bar)}}{10} = \text{PN (MPa)}$$

*Please add the suffixes below according to the material / surface required.

Order code suffixes					
Material	Suffix surface and material	Example only 4 bolt flange	Example 4 bolt flange incl. metr. screws and O-ring	Example 4 bolt flange incl. UNC screws and O-ring	Standard sealing material (no additional suffix needed)
Steel, blanc oil dipped	S	PAFS080MAS	PAFS080MASM	PAFS080MASU	NBR
Stainless steel	SS	PAFS080MASS	PAFS080MASSM	PAFS080MASSU	VIT

PAFS-U SAE Straight 4 bolt flange with UN/UNF thread

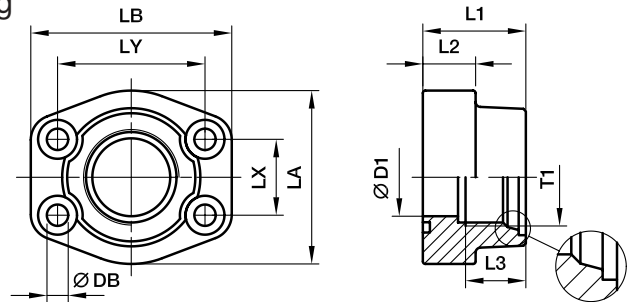
 SAE Flange / Female UN/UNF thread for O-ring
 (ISO 6162-1/-2) (ISO 11926-1)

3000 PSI Series

Nom. flange size		T1	D1	L1	L2	L3	LA	LB	LX	LY	DB	Screws		Weight (steel) kg/piece	Order code*	PN (bar) ¹⁾		
SAE (in)	ISO (DN)											(metr.)	(unc.)			S	SS	
1/2	13	3/4-16UNF-2A	13	36	16	17	46	58	17.5	38.1	9.0	M 8	30	5/16 1 1/4	0.30	PAFS080UA	345	345
3/4	19	7/8-14UNF-2A	19	36	18	17	49	66	22.3	47.6	10.5	M10	35	3/8 1 1/2	0.45	PAFS100UA	345	345
3/4	19	1 1/16-12UN-2A	19	36	18	23	49	66	22.3	47.6	10.5	M10	35	3/8 1 1/2	0.42	PAFS100UB	345	345
1	25	1 1/16-12UN-2A	25	38	18	23	53	71	26.2	52.4	10.5	M10	35	3/8 1 1/2	0.48	PAFS102UA	345	345
1	25	1 5/16-12UN-2A	25	38	18	23	53	71	26.2	52.4	10.5	M10	35	3/8 1 1/2	0.45	PAFS102UB	276	276
1 1/4	32	1 5/16-12UN-2A	31	41	21	23	69	80	30.2	58.7	10.5	M10	35	7/16 1 1/2	0.84	PAFS104UA	207	207
1 1/4	32	1 5/8-12UN-2A	31	41	21	23	69	80	30.2	58.7	10.5	M10	35	7/16 1 1/2	0.71	PAFS104UB	207	207
1 1/2	38	1 5/8-12UN-2A	38	44	25	23	77	94	35.7	69.9	13.5	M12	45	1/2 1 3/4	1.25	PAFS106UA	172	172
1 1/2	38	1 7/8-12UN-2A	38	44	25	23	77	94	35.7	69.9	13.5	M12	45	1/2 1 3/4	1.14	PAFS106UB	138	138

6000 PSI Series

1/2	13	3/4-16UNF-2A	13	36	16	17	46	58	18.2	40.5	9.0	M 8	30	5/16 1 1/4	0.30	PAFS401UA	420	420
3/4	19	7/8-14UNF-2A	19	36	19	17	53	71	23.8	50.8	10.5	M10	35	5/16 1 1/4	0.53	PAFS402UA	420	420
3/4	19	1 1/16-12UN-2A	19	36	19	23	53	71	23.8	50.8	10.5	M10	35	3/8 1 1/2	0.50	PAFS402UB	420	420
1	25	1 1/16-12UN-2A	25	44	24	23	69	80	27.8	57.2	13.5	M12	45	3/8 1 1/2	0.86	PAFS403UA	420	420
1	25	1 5/16-12UN-2A	25	44	24	23	69	80	27.8	57.2	13.5	M12	45	7/16 1 1/2	0.84	PAFS403UB	420	420
1 1/4	32	1 5/16-12UN-2A	31	44	27	23	77	94	31.8	66.6	15.0	M14	45	7/16 1 1/2	1.30	PAFS404UA	420	420
1 1/4	32	1 5/8-12UN-2A	31	44	27	23	77	94	31.8	66.6	15.0	M14	45	1/2 1 3/4	1.25	PAFS404UB	420	420
1 1/2	38	1 5/8-12UN-2A	38	51	30	23	89	106	36.5	79.3	17.0	M16	50	1/2 1 3/4	1.78	PAFS405UA	420	420
1 1/2	38	1 7/8-12UN-2A	38	51	30	23	89	106	36.5	79.3	18.0	M16	50	5/8 2	1.70	PAFS405UB	420	420

¹⁾ Pressure shown = Item deliverable

$$\frac{PN \text{ (bar)}}{10} = PN \text{ (MPa)}$$

*Please add the suffixes below according to the material / surface required.

Order code suffixes					
Material	Suffix surface and material	Example only 4 bolt flange	Example 4 bolt flange incl. metr. screws and O-ring	Example 4 bolt flange incl. UNC screws and O-ring	Standard sealing material (no additional suffix needed)
Steel, blanc oil dipped	S	PAFS080UAS	PAFS080UASM	PAFS080UASU	NBR
Stainless steel	SS	PAFS080UASS	PAFS080UASSM	PAFS080UASSU	VIT

PFF-..S/L SAE Straight 4 bolt flange with EO 24° cone end

SAE Flange / EO 24° cone end
(ISO 6162-1/-2)

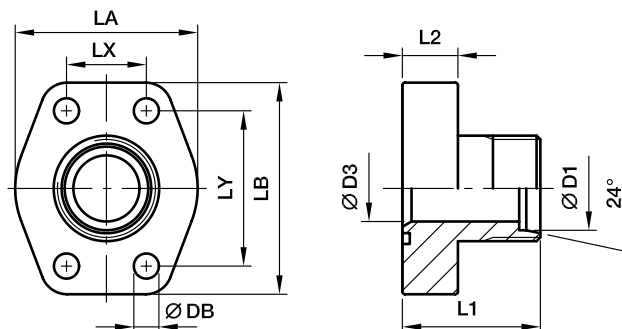

3000 PSI Series

Nom. flange size		D1 ²⁾	D3	L1	L2	LA	LB	LX	LY	DB	Screws		Weight (steel) kg/piece	Order code*	PN (bar) ¹⁾	
SAE (in)	ISO (DN)										(metr.)	(unc.)			A3C	SS
1/2	13	12S	8	47	16	42	57	17.5	38.1	9.0	M 8 30	5/16 1 1/4	0.25	PFF32/12S	348	348
1/2	13	15L	11	47	16	42	57	17.5	38.1	9.0	M 8 30	5/16 1 1/4	0.29	PFF32/15L	348	315
1/2	13	16S	12	47	16	42	57	17.5	38.1	9.0	M 8 30	5/16 1 1/4	0.32	PFF32/16S	348	348
3/4	19	16S	12	52	18	50	66	22.3	47.6	11.0	M10 35	3/8 1 1/2	0.35	PFF33/16S	348	348
3/4	19	20S	16	52	18	50	66	22.3	47.6	11.0	M10 35	3/8 1 1/2	0.36	PFF33/20S	348	348
3/4	19	22L	18	52	18	50	66	22.3	47.6	11.0	M10 35	3/8 1 1/2	0.37	PFF33/22L	250	160
1	25	20S	16	55	18	53	71	26.2	52.4	11.0	M10 35	3/8 1 1/2	0.44	PFF34/20S	348	348
1	25	25S	20	55	18	53	71	26.2	52.4	11.0	M10 35	3/8 1 1/2	0.46	PFF34/25S	348	348
1	25	28L	23	55	18	53	71	26.2	52.4	11.0	M10 35	3/8 1 1/2	0.50	PFF34/28L	250	160
1 1/4	32	25S	20	60	21	69	80	30.2	58.7	11.5	M10 35	7/16 1 1/2	0.65	PFF35/25S	278	278
1 1/4	32	30S	25	60	21	69	80	30.2	58.7	11.5	M10 35	7/16 1 1/2	0.70	PFF35/30S	278	278
1 1/4	32	35L	30	60	21	69	80	30.2	58.7	11.5	M10 40	7/16 1 1/2	0.72	PFF35/35L	278	278
1 1/2	38	35L	30	70	25	77	94	35.7	69.9	13.5	M12 45	1/2 1 3/4	1.00	PFF36/35L	210	210
1 1/2	38	38S	32	70	25	77	94	35.7	69.9	13.5	M12 45	1/2 1 3/4	1.00	PFF36/38S	210	210
1 1/2	38	42L	36	70	25	77	94	35.7	69.9	13.5	M12 45	1/2 1 3/4	1.02	PFF36/42L	210	210
2	51	42L	32	74	25	90	103	42.9	77.8	13.5	M12 45	1/2 1 3/4	1.40	PFF38/38S	210	210
2	51	38S	36	74	25	90	103	42.9	77.8	13.5	M12 45	1/2 1 3/4	1.35	PFF38/42L	210	210

6000 PSI Series

1/2	13	12S	8	47	16	47	57	18.3	40.5	9.0	M 8 30	5/16 1 1/4	0.30	PFF62/12S	420	420
1/2	13	14S	10	47	16	47	57	18.3	40.5	9.0	M 8 30	5/16 1 1/4	0.32	PFF62/14S	420	420
1/2	13	16S	12	47	16	47	57	18.3	40.5	9.0	M 8 30	5/16 1 1/4	0.35	PFF62/16S	420	420
3/4	19	16S	12	52	18	53	71	23.8	50.8	11.0	M10 35	3/8 1 1/2	0.68	PFF63/16S	420	420
3/4	19	20S	16	52	18	53	71	23.8	50.8	11.0	M10 35	3/8 1 1/2	0.73	PFF63/20S	420	400
3/4	19	22L	18	52	18	53	71	23.8	50.8	11.0	M10 35	3/8 1 1/2	0.82	PFF63/22L	250	160
1	25	20S	16	60	21	66	80	27.8	57.2	13.0	M12 45	7/16 1 1/2	1.00	PFF64/20S	420	400
1	25	25S	20	60	21	66	80	27.8	57.2	13.0	M12 45	7/16 1 1/2	1.15	PFF64/25S	420	400
1	25	28L	23	60	21	66	80	27.8	57.2	13.0	M12 45	7/16 1 1/2	1.20	PFF64/28L	250	160
1 1/4	32	25S	20	68	24	78	94	31.8	66.6	15.0	M14 45	1/2 1 3/4	1.60	PFF65/25S	420	400
1 1/4	32	30S	25	68	24	78	94	31.8	66.6	15.0	M14 45	1/2 1 3/4	1.80	PFF65/30S	420	400
1 1/4	32	35L	30	68	24	78	94	31.8	66.6	15.0	M14 45	1/2 1 3/4	1.85	PFF65/35L	250	160
1 1/2	38	35L	25	72	27	90	106	36.5	79.3	17.0	M16 50	5/8 2	2.20	PFF66/35L	250	160
1 1/2	38	38S	32	72	27	90	106	36.5	79.3	17.0	M16 50	5/8 2	2.25	PFF66/38S	315	315
1 1/2	38	42L	36	72	27	90	106	36.5	79.3	17.0	M16 50	5/8 2	2.35	PFF66/42L	250	160

²⁾ L = light series; S = heavy series

*Please add the suffixes below according to the material / surface required.

Delivery without nut and ring.
Information on ordering complete fittings or alternative sealing materials see page M11.

¹⁾ Pressure shown = Item deliverable

$$\frac{PN \text{ (bar)}}{10} = PN \text{ (MPa)}$$

Order code suffixes					
Material	Suffix surface and material	Example only 4 bolt flange	Example 4 bolt flange incl. metr. screws and O-ring	Example 4 bolt flange incl. UNC screws and O-ring	Standard sealing material (no additional suffix needed)
Steel, zinc plated, chrome ⁶ -free	CF	PFF32/12SCF	PFF32/12SOMDCFM	PFF32/12SOMDCFU	NBR
Steel, zinc yellow plated	A3C	PFF32/12SA3C	PFF32/12SOMDA3CM	PFF32/12SOMDA3CU	NBR
Stainless steel	SS	PFF32/12S-SS	PFF32/12SOMDSSM	PFF32/12SOMDSSU	VIT

PAFG-90M SAE 90° 4 bolt flange with EO 24° cone end

SAE 90° Flange / EO 24° cone end
(ISO 6162-1/-2)

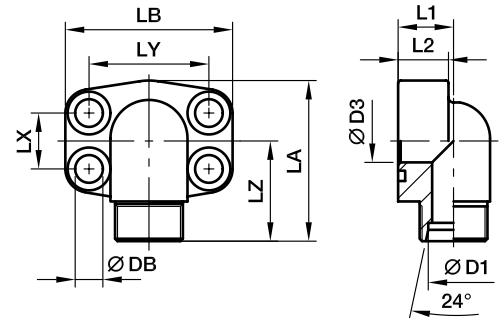

3000 PSI Series

Nom. flange size		D1 ²⁾	D3	L1	L2	LA	LB	LX	LY	LZ	DB	Screws		Weight (steel) kg/piece	Order code*	PN (bar) ¹⁾	
SAE (in)	ISO (DN)											(metr.)	(unc.)			A3C	SS
1/2	13	12S	8	18	16	60	57	17.5	38.1	36	9.0	M 8 30	5/16 1 1/4	0.28	PAFG080/90M12S	348	348
1/2	13	15L	11	18	16	60	57	17.5	38.1	36	9.0	M 8 30	5/16 1 1/4	0.33	PAFG080/90M15L	348	315
1/2	13	16S	12	18	16	60	57	17.5	38.1	36	9.0	M 8 30	5/16 1 1/4	0.30	PAFG080/90M16S	348	348
3/4	19	16S	12	22	18	63	66	22.3	47.6	38	11.0	M10 35	3/8 1 1/2	0.43	PAFG100/90M16S	348	348
3/4	19	20S	16	22	18	63	66	22.3	47.6	38	11.0	M10 35	3/8 1 1/2	0.43	PAFG100/90M20S	348	348
3/4	19	22L	18	22	18	63	66	22.3	47.6	38	11.0	M10 35	3/8 1 1/2	0.43	PAFG100/90M22L	250	160
1	25	20S	16	28	19	80	71	26.2	52.4	42	11.0	M10 35	3/8 1 1/2	0.68	PAFG102/90M20S	348	348
1	25	25S	20	28	19	80	71	26.2	52.4	42	11.0	M10 35	3/8 1 1/2	0.64	PAFG102/90M25S	348	348
1	25	28L	23	28	19	80	71	26.2	52.4	42	11.0	M10 35	3/8 1 1/2	0.62	PAFG102/90M28L	250	160
1 1/4	32	25S	20	30	22	84	80	30.2	58.7	50	11.5	M10 35	7/16 1 1/2	1.15	PAFG104/90M25S	278	278
1 1/4	32	30S	25	30	22	84	80	30.2	58.7	50	11.5	M10 35	7/16 1 1/2	1.02	PAFG104/90M30S	278	278
1 1/4	32	35L	30	30	22	84	80	30.2	58.7	50	11.5	M10 40	7/16 1 1/2	0.94	PAFG104/90M35L	278	278
1 1/2	38	35L	30	36	25	88	94	35.7	69.9	58	13.5	M12 45	1/2 1 3/4	1.50	PAFG106/90M35L	210	210
1 1/2	38	38S	32	36	25	88	94	35.7	69.9	58	13.5	M12 45	1/2 1 3/4	1.50	PAFG106/90M38S	210	210
1 1/2	38	42L	36	36	25	88	94	35.7	69.9	58	13.5	M12 45	1/2 1 3/4	1.50	PAFG106/90M42L	210	210

6000 PSI Series

1/2	13	12S	8	20	16	60	57	18.2	40.5	36	9.0	M 8 30	5/16 1 1/4	0.30	PAFG401/90M12S	420	420
1/2	13	14S	10	20	16	60	57	18.2	40.5	36	9.0	M 8 30	5/16 1 1/4	0.32	PAFG401/90M14S	420	420
1/2	13	16S	12	20	16	60	57	18.2	40.5	36	9.0	M 8 30	5/16 1 1/4	0.35	PAFG401/90M16S	420	420
3/4	19	16S	12	26	19	68	71	23.8	50.8	41	11.0	M10 35	3/8 1 1/2	0.53	PAFG402/90M16S	420	420
3/4	19	20S	20	26	19	68	71	23.8	50.8	41	11.0	M10 35	3/8 1 1/2	0.53	PAFG402/90M20S	420	400
3/4	19	22L	23	26	19	68	71	23.8	50.8	41	11.0	M10 35	3/8 1 1/2	0.53	PAFG402/90M22L	250	160
1	25	20S	16	30	24	83	80	27.8	57.2	50	13.0	M12 45	7/16 1 1/2	0.90	PAFG403/90M20S	420	400
1	25	25S	20	30	24	83	80	27.8	57.2	50	13.0	M12 45	7/16 1 1/2	0.90	PAFG403/90M25S	420	400
1	25	28L	23	30	24	83	80	27.8	57.2	50	13.0	M12 45	7/16 1 1/2	0.90	PAFG403/90M28L	250	160
1 1/4	32	25S	20	36	25	97	94	31.8	66.6	58	15.0	M14 45	1/2 1 3/4	1.35	PAFG404/90M25S	420	400
1 1/4	32	30S	25	36	25	97	94	31.8	66.6	58	15.0	M14 45	1/2 1 3/4	1.40	PAFG404/90M30S	420	400
1 1/4	32	35L	30	36	25	97	94	31.8	66.6	58	15.0	M14 45	1/2 1 3/4	1.45	PAFG404/90M35L	250	160
1 1/2	38	35L	25	41	26	110	106	36.5	79.3	65	17.0	M16 50	5/8 2	1.80	PAFG405/90M35L	250	160
1 1/2	38	38S	32	41	26	110	106	36.5	79.3	65	17.0	M16 50	5/8 2	1.85	PAFG405/90M38S	315	315
1 1/2	38	42L	36	41	26	110	106	36.5	79.3	65	17.0	M16 50	5/8 2	1.90	PAFG405/90M42L	250	160

²⁾ L = light series; S = heavy series

Delivery without nut and ring.
Information on ordering complete fittings
or alternative sealing materials see page M11.

¹⁾ Pressure shown = Item deliverable

$$\frac{PN \text{ (bar)}}{10} = PN \text{ (MPa)}$$

*Please add the suffixes below according to the material / surface required.

Order code suffixes					
Material	Suffix surface and material	Example only 4 bolt flange	Example 4 bolt flange incl. metr. screws and O-ring	Example 4 bolt flange incl. UNC screws and O-ring	Standard sealing material (no additional suffix needed)
Steel, zinc plated, chrome ⁶ -free	CF	PAFG080/90M12SCF	PAFG080/90M12SOMDCFM	PAFG080/90M12SOMDCFU	NBR
Steel, zinc yellow plated	A3C	PAFG080/90M12SA3C	PAFG080/90M12SOMDA3CM	PAFG080/90M12SOMDA3CU	NBR
Stainless steel	SS	PAFG080/90M12S-SS	PAFG080/90M12SOMDSSM	PAFG080/90M12SOMDSSU	VIT



PAFG-G SAE Straight 4 bolt flange with BSPP 60° cone end

SAE Flange / BSPP 60° cone end
(ISO 6162-1/-2) (ISO 8434-6)

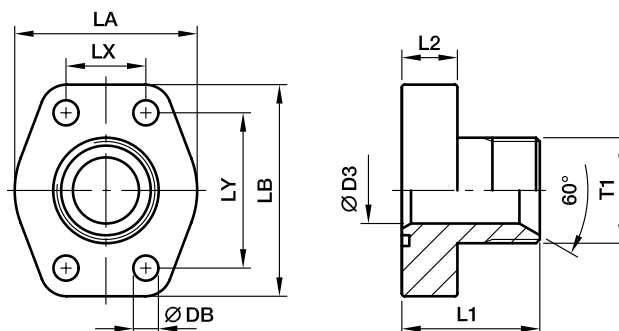

3000 PSI Series

Nom. flange size		T1	D3	L1	L2	LA	LB	LX	LY	DB	Screws		Weight (steel) kg/piece	Order code*	PN (bar) ¹⁾	
SAE (in)	ISO (DN)										(metr.)	(unc.)			A3C	SS
1/2	13	G3/8	10	37	16	47	56	17.5	38.1	9.0	M 8 30	5/16 1 1/4	0.25	PAFG080G38	348	348
1/2	13	G1/2	12	39	16	47	56	17.5	38.1	9.0	M 8 30	5/16 1 1/4	0.29	PAFG080G	348	348
1/2	13	G3/4	13	42	16	47	56	17.5	38.1	9.0	M 8 30	5/16 1 1/4	0.32	PAFG080G34	348	348
3/4	19	G1/2	12	42	18	50	66	22.3	47.6	11.0	M10 35	3/8 1 1/2	0.35	PAFG100G12	348	348
3/4	19	G3/4	17	45	18	50	66	22.3	47.6	11.0	M10 35	3/8 1 1/2	0.34	PAFG100G	348	348
3/4	19	G1	19	47	18	50	66	22.3	47.6	11.0	M10 35	3/8 1 1/2	0.37	PAFG100G1	348	348
1	25	G3/4	17	47	18	53	71	26.2	52.4	11.0	M10 35	3/8 1 1/2	0.44	PAFG102G34	348	348
1	25	G1	22	49	18	53	71	26.2	52.4	11.0	M10 35	3/8 1 1/2	0.46	PAFG102G	348	348
1	25	G1 1/4	25	49	18	53	71	26.2	52.4	11.0	M10 35	3/8 1 1/2	0.50	PAFG102G114	348	348
1 1/4	32	G1	22	53	21	69	80	30.2	58.7	11.5	M10 35	7/16 1 1/2	0.65	PAFG104G1	278	278
1 1/4	32	G1 1/4	27	53	21	69	80	30.2	58.7	11.5	M10 35	7/16 1 1/2	0.70	PAFG104G	278	278
1 1/4	32	G1 1/2	31	55	21	69	80	30.2	58.7	11.5	M10 40	7/16 1 1/2	0.72	PAFG104G112	278	278
1 1/2	38	G1 1/4	27	59	24	77	94	35.7	69.9	13.5	M12 45	1/2 1 3/4	1.00	PAFG106G114	210	210
1 1/2	38	G1 1/2	34	61	24	77	94	35.7	69.9	13.5	M12 45	1/2 1 3/4	1.00	PAFG106G	210	210
1 1/2	38	G2	38	63	24	77	94	35.7	69.9	13.5	M12 45	1/2 1 3/4	1.02	PAFG106G2	210	210
2	51	G1 1/2	34	69	25	90	103	42.9	77.8	13.5	M12 45	1/2 1 3/4	1.40	PAFG108G112	210	210
2	51	G2	42	69	25	90	103	42.9	77.8	13.5	M12 45	1/2 1 3/4	1.35	PAFG108G	210	210

6000 PSI Series

1/2	13	G3/8	10	38	16	47	56	18.2	40.5	9.0	M 8 30	5/16 1 1/4	0.30	PAFG401G38	420	420
1/2	13	G1/2	12	40	16	47	56	18.2	40.5	9.0	M 8 30	5/16 1 1/4	0.32	PAFG401G	420	420
1/2	13	G3/4	13	43	16	47	56	18.2	40.5	9.0	M 8 30	5/16 1 1/4	0.35	PAFG401G34	420	420
3/4	19	G1/2	12	44	18	53	71	23.8	50.8	11.0	M10 35	3/8 1 1/2	0.68	PAFG402G12	420	420
3/4	19	G3/4	17	47	18	53	71	23.8	50.8	11.0	M10 35	3/8 1 1/2	0.73	PAFG402G	420	420
3/4	19	G1	19	49	18	53	71	23.8	50.8	11.0	M10 35	3/8 1 1/2	0.82	PAFG402G1	420	420
1	25	G3/4	17	54	21	66	80	27.8	57.2	13.0	M12 45	7/16 1 1/2	1.00	PAFG403G34	420	420
1	25	G1	22	56	21	66	80	27.8	57.2	13.0	M12 45	7/16 1 1/2	1.15	PAFG403G	420	420
1	25	G1 1/4	25	56	21	66	80	27.8	57.2	13.0	M12 45	7/16 1 1/2	1.20	PAFG403G114	420	420
1 1/4	32	G1	22	61	24	78	94	31.8	66.6	15.0	M14 45	1/2 1 3/4	1.60	PAFG404G1	420	420
1 1/4	32	G1 1/4	27	61	24	78	94	31.8	66.6	15.0	M14 45	1/2 1 3/4	1.80	PAFG404G	420	420
1 1/4	32	G1 1/2	31	63	24	78	94	31.8	66.6	15.0	M14 45	1/2 1 3/4	1.85	PAFG404G112	420	420
1 1/2	38	G1 1/4	27	65	27	90	106	36.5	79.3	17.0	M16 50	5/8 2	2.20	PAFG405G114	420	420
1 1/2	38	G1 1/2	32	67	27	90	106	36.5	79.3	17.0	M16 50	5/8 2	2.25	PAFG405G	420	420

¹⁾ Pressure shown = Item deliverable

$$\frac{\text{PN (bar)}}{10} = \text{PN (MPa)}$$

*Please add the suffixes below according to the material / surface required.

Order code suffixes					
Material	Suffix surface and material	Example only 4 bolt flange	Example 4 bolt flange incl. metr. screws and O-ring	Example 4 bolt flange incl. UNC screws and O-ring	Standard sealing material (no additional suffix needed)
Steel, zinc plated, chrome ⁶ -free	CF	PAFG080GCF	PAFG080GCFM	PAFG080GCFU	NBR
Steel, zinc yellow plated	A3C	PAFG080GA3C	PAFG080GA3CM	PAFG080GA3CU	NBR
Stainless steel	SS	PAFG080GSS	PAFG080GSSM	PAFG080GSSU	VIT

PAFG-90G SAE 90° 4 bolt flange with BSPP 60° cone end

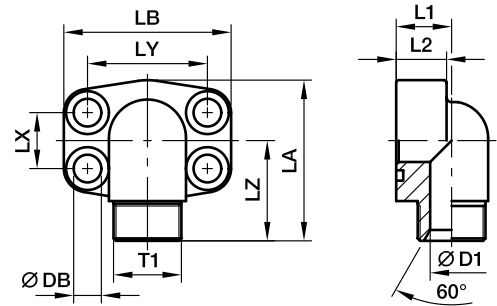
 SAE 90° Flange / BSPP 60° cone end
 (ISO 6162-1/-2) (ISO 8434-6)

3000 PSI Series

Nom. flange size		T1	D3	L1	L2	LA	LB	LX	LY	LZ	DB	Screws		Weight (steel) kg/piece	Order code*	PN (bar) ¹⁾	
SAE (in)	ISO (DN)											(metr.)	(unc.)			A3C	SS
1/2	13	G3/8	10	17	16	60	57	17.5	38.1	37	9.0	M 8 30	5/16 1 1/4	0.27	PAFG080/90G38	348	348
1/2	13	G1/2	12	17	16	60	57	17.5	38.1	39	9.0	M 8 30	5/16 1 1/4	0.31	PAFG080/90G	348	348
1/2	13	G3/4	13	20	16	60	57	17.5	38.1	40	9.0	M 8 30	5/16 1 1/4	0.31	PAFG080/90G34	348	348
3/4	19	G1/2	12	20	18	63	66	22.3	47.6	41	11.0	M10 35	3/8 1 1/2	0.47	PAFG100/90G12	348	348
3/4	19	G3/4	17	20	18	63	66	22.3	47.6	44	11.0	M10 35	3/8 1 1/2	0.42	PAFG100/90G	348	348
3/4	19	G1	19	25	18	63	66	22.3	47.6	45	11.0	M10 35	3/8 1 1/2	0.60	PAFG100/90G1	348	348
1	25	G3/4	17	20	19	80	71	26.2	52.4	47	11.0	M10 35	3/8 1 1/2	0.66	PAFG102/90G34	348	348
1	25	G1	22	25	19	80	71	26.2	52.4	48	11.0	M10 35	3/8 1 1/2	0.62	PAFG102/90G	348	348
1	25	G1 1/4	25	31	19	80	71	26.2	52.4	49	11.0	M10 35	3/8 1 1/2	0.65	PAFG102/90G114	348	348
1 1/4	32	G1	22	25	22	84	80	30.2	58.7	54	11.5	M10 35	7/16 1 1/2	1.06	PAFG104/90G1	278	278
1 1/4	32	G1 1/4	27	31	22	84	80	30.2	58.7	55	11.5	M10 35	7/16 1 1/2	0.93	PAFG104/90G	278	278
1 1/4	32	G1 1/2	31	37	22	84	80	30.2	58.7	56	11.5	M10 40	7/16 1 1/2	0.96	PAFG104/90G112	278	278
1 1/2	38	G1 1/4	27	31	25	88	94	35.7	69.9	59	13.5	M12 45	1/2 1 3/4	1.44	PAFG106/90G114	210	210
1 1/2	38	G1 1/2	34	37	25	88	94	35.7	69.9	61	13.5	M12 45	1/2 1 3/4	1.35	PAFG106/90G	210	210

6000 PSI Series

1/2	13	G3/8	10	17	16	60	57	18.2	40.5	37	9.0	M 8 30	5/16 1 1/4	0.30	PAFG401/90G38	420	420
1/2	13	G1/2	12	17	16	60	57	18.2	40.5	39	9.0	M 8 30	5/16 1 1/4	0.32	PAFG401/90G	420	420
1/2	13	G3/4	13	20	16	60	57	18.2	40.5	40	9.0	M 8 30	5/16 1 1/4	0.35	PAFG401/90G34	420	420
3/4	19	G1/2	12	20	19	68	71	23.8	50.8	45	11.0	M10 35	3/8 1 1/2	0.53	PAFG402/90G12	420	420
3/4	19	G3/4	17	20	19	68	71	23.8	50.8	48	11.0	M10 35	3/8 1 1/2	0.53	PAFG402/90G	420	420
3/4	19	G1	19	25	19	68	71	23.8	50.8	50	11.0	M10 35	3/8 1 1/2	0.53	PAFG402/90G1	420	420
1	25	G3/4	17	25	24	83	80	27.8	57.2	52	13.0	M12 45	7/16 1 1/2	0.90	PAFG403/90G34	420	420
1	25	G1	22	25	24	83	80	27.8	57.2	54	13.0	M12 45	7/16 1 1/2	0.90	PAFG403/90G	420	420
1	25	G1 1/4	25	31	24	83	80	27.8	57.2	55	13.0	M12 45	7/16 1 1/2	0.90	PAFG403/90G114	420	420
1 1/4	32	G1	22	31	25	97	94	31.8	66.6	59	15.0	M14 45	1/2 1 3/4	1.35	PAFG404/90G1	420	420
1 1/4	32	G1 1/4	27	31	25	97	94	31.8	66.6	59	15.0	M14 45	1/2 1 3/4	1.40	PAFG404/90G	420	420
1 1/4	32	G1 1/2	31	37	25	97	94	31.8	66.6	61	15.0	M14 45	1/2 1 3/4	1.45	PAFG404/90G112	420	420
1 1/2	38	G1 1/4	27	37	26	110	106	36.5	79.3	64	17.0	M16 50	5/8 2	1.80	PAFG405/90G114	420	420
1 1/2	38	G1 1/2	32	37	26	110	106	36.5	79.3	66	17.0	M16 50	5/8 2	1.85	PAFG405/90G	420	420

1) Pressure shown = Item deliverable

$$\frac{\text{PN (bar)}}{10} = \text{PN (MPa)}$$

*Please add the suffixes below according to the material / surface required.

Order code suffixes					
Material	Suffix surface and material	Example only 4 bolt flange	Example 4 bolt flange incl. metr. screws and O-ring	Example 4 bolt flange incl. UNC screws and O-ring	Standard sealing material (no additional suffix needed)
Steel, zinc plated, chrome ⁶ -free	CF	PAFG080/90GCF	PAFG080/90GCFM	PAFG080/90GCFU	NBR
Steel, zinc yellow plated	A3C	PAFG080/90GA3C	PAFG080/90GA3CM	PAFG080/90GA3CU	NBR
Stainless steel	SS	PAFG080/90GSS	PAFG080/90GSSM	PAFG080/90GSSU	VIT

PAFG-X SAE Straight 4 bolt flange with Triple-Lok® 37° flare end

SAE Flange / Triple-Lok® 37° flare end
(ISO 6162-1/-2)

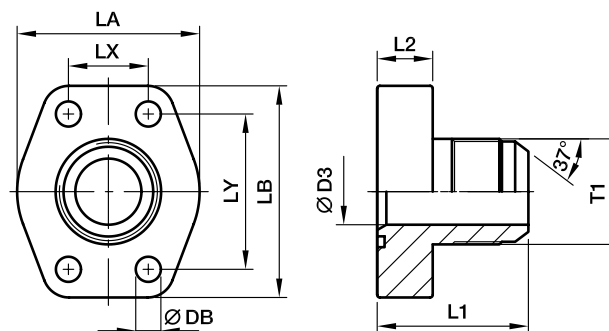

3000 PSI Series

Nom. flange size		T1	D3	L1	L2	LA	LB	LX	LY	DB	Screws		Weight (steel) kg/piece	Order code*	PN (bar) ¹⁾	
SAE (in)	ISO (DN)										(metr.)	(unc.)			A3C	SS
1/2	13	3/4-16UNF-2A	9.9	41	16	47	57	17.5	38.1	9.0	M 8 30	5/16 1 1/4	0.25	PAFG080X-A	348	348
1/2	13	7/8-14UNF-2A	12.3	41	16	47	57	17.5	38.1	9.0	M 8 30	5/16 1 1/4	0.29	PAFG080X-B	348	348
1/2	13	1 1/16-12UN-2A	12.3	46	16	47	57	17.5	38.1	9.0	M 8 30	5/16 1 1/4	0.32	PAFG080X-C	348	348
3/4	19	7/8-14UN-2A	12.3	47	18	50	66	22.3	47.6	11.0	M10 35	3/8 1 1/2	0.35	PAFG100X-A	348	348
3/4	19	1 1/16-12UN-2A	15.5	49	18	50	66	22.3	47.6	11.0	M10 35	3/8 1 1/2	0.34	PAFG100X-B	348	348
3/4	19	1 5/16-12UN-2A	21.5	50	18	50	66	22.3	47.6	11.0	M10 35	3/8 1 1/2	0.37	PAFG100X-C	348	348
1	25	1 1/16-12UN-2A	15.5	51	18	53	71	26.2	52.4	11.0	M10 35	3/8 1 1/2	0.44	PAFG102X-A	348	348
1	25	1 5/16-12UN-2A	21.5	52	18	53	71	26.2	52.4	11.0	M10 35	3/8 1 1/2	0.46	PAFG102X-B	348	348
1	25	1 5/8-12UN-2A	27.5	54	18	53	71	26.2	52.4	11.0	M10 35	3/8 1 1/2	0.50	PAFG102X-C	348	348
1 1/4	32	1 5/16-12UN-2A	21.5	56	21	69	80	30.2	58.7	11.5	M10 35	7/16 1 1/2	0.65	PAFG104X-A	278	278
1 1/4	32	1 5/8-12UN-2A	27.5	58	21	69	80	30.2	58.7	11.5	M10 35	7/16 1 1/2	0.70	PAFG104X-B	278	278
1 1/4	32	1 7/8-12UN-2A	33.0	61	21	69	80	30.2	58.7	11.5	M10 40	7/16 1 1/2	0.72	PAFG104X-C	278	278
1 1/2	38	1 5/8-12UN-2A	27.5	64	24	77	94	35.7	69.9	13.5	M12 45	1/2 1 3/4	1.00	PAFG106X-A	210	210
1 1/2	38	1 7/8-12UN-2A	33.0	67	24	77	94	35.7	69.9	13.5	M12 45	1/2 1 3/4	1.00	PAFG106X-B	210	210

6000 PSI Series

1/2	13	3/4-16UNF-2A	9.9	42	16	47	57	18.2	40.5	9.0	M 8 30	5/16 1 1/4	0.30	PAFG401X-A	350	350
1/2	13	7/8-14UNF-2A	12.3	45	16	47	57	18.2	40.5	9.0	M 8 30	5/16 1 1/4	0.32	PAFG401X-B	350	350
1/2	13	1 1/16-12UN-2A	12.3	47	16	47	57	18.2	40.5	9.0	M 8 30	5/16 1 1/4	0.35	PAFG401X-C	350	350
3/4	19	7/8-14UN-2A	12.3	49	18	53	71	23.8	50.8	11.0	M10 35	3/8 1 1/2	0.68	PAFG402X-A	350	350
3/4	19	1 1/16-12UN-2A	15.5	51	18	53	71	23.8	50.8	11.0	M10 35	3/8 1 1/2	0.73	PAFG402X-B	350	350
3/4	19	1 5/16-12UN-2A	21.5	52	18	53	71	23.8	50.8	11.0	M10 35	3/8 1 1/2	0.82	PAFG402X-C	350	350
1	25	1 1/16-12UN-2A	15.5	58	21	66	80	27.8	57.2	13.0	M12 45	7/16 1 1/2	1.00	PAFG403X-A	350	350
1	25	1 5/16-12UN-2A	21.5	59	21	66	80	27.8	57.2	13.0	M12 45	7/16 1 1/2	1.15	PAFG403X-B	350	350
1	25	1 5/8-12UN-2A	27.5	61	21	66	80	27.8	57.2	13.0	M12 45	7/16 1 1/2	1.20	PAFG403X-C	275	275
1 1/4	32	1 5/16-12UN-2A	21.5	64	24	78	94	31.8	66.6	15.0	M14 45	1/2 1 3/4	1.60	PAFG404X-A	350	350
1 1/4	32	1 5/8-12UN-2A	27.5	66	24	78	94	31.8	66.6	15.0	M14 45	1/2 1 3/4	1.80	PAFG404X-B	275	275
1 1/4	32	1 7/8-12UN-2A	33.0	69	24	78	94	31.8	66.6	15.0	M14 45	1/2 1 3/4	1.85	PAFG404X-C	210	210
1 1/2	38	1 5/8-12UN-2A	27.5	70	27	90	106	36.5	79.3	17.0	M16 50	5/8 2	2.20	PAFG405X-A	275	275
1 1/2	38	1 7/8-12UN-2A	33.0	73	27	90	106	36.5	79.3	17.0	M16 50	5/8 2	2.25	PAFG405X-B	210	210

1) Pressure shown = Item deliverable

$$\frac{\text{PN (bar)}}{10} = \text{PN (MPa)}$$

*Please add the suffixes below according to the material / surface required.

Order code suffixes					
Material	Suffix surface and material	Example only 4 bolt flange	Example 4 bolt flange incl. metr. screws and O-ring	Example 4 bolt flange incl. UNC screws and O-ring	Standard sealing material (no additional suffix needed)
Steel, zinc plated, chrome ⁶ -free	CF	PAFG080X-ACF	PAFG080X-ACFM	PAFG080X-ACFU	NBR
Steel, zinc yellow plated	A3C	PAFG080X-AA3C	PAFG080X-AA3CM	PAFG080X-AA3CU	NBR
Stainless steel	SS	PAFG080X-ASS	PAFG080X-ASSM	PAFG080X-ASSU	VIT

PAFG-90X SAE 90° 4 bolt flange with Triple-Lok® 37° flare end

SAE 90° Flange / Triple-Lok® 37° flare end
(ISO 6162-1/-2)

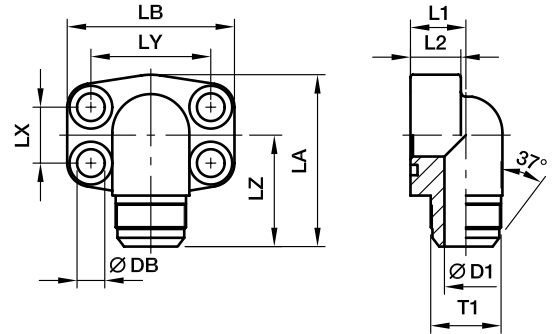

3000 PSI Series

Nom. flange size												Screws		Weight (steel) kg/piece	Order code*	PN (bar) ¹⁾	
SAE (in)	ISO (DN)	T1	D1	L1	L2	LA	LB	LX	LY	LZ	DB	(metr.)	(unc.)			A3C	SS
1/2	13	3/4-16	9.9	17	16	60	56	17.5	38.1	40	9.0	M 8 30	5/16 1 1/4	0.27	PAFG080/90X-A	348	348
1/2	13	7/8-14	12.3	17	16	60	56	17.5	38.1	42	9.0	M 8 30	5/16 1 1/4	0.31	PAFG080/90X-B	348	348
1/2	13	1 1/16-12	12.3	20	16	60	56	17.5	38.1	43	9.0	M 8 30	5/16 1 1/4	0.31	PAFG080/90X-C	348	348
3/4	19	7/8-14	12.3	20	18	63	66	22.3	47.6	45	11.0	M10 35	3/8 1 1/2	0.47	PAFG100/90X-A	348	348
3/4	19	1 1/16-12	15.5	20	18	63	66	22.3	47.6	47	11.0	M10 35	3/8 1 1/2	0.42	PAFG100/90X-B	348	348
3/4	19	1 5/16-12	21.5	25	18	63	66	22.3	47.6	48	11.0	M10 35	3/8 1 1/2	0.60	PAFG100/90X-C	348	348
1	25	1 1/16-12	15.5	20	19	80	71	26.2	52.4	50	11.0	M10 35	3/8 1 1/2	0.66	PAFG102/90X-A	348	348
1	25	1 5/16-12	21.5	25	19	80	71	26.2	52.4	51	11.0	M10 35	3/8 1 1/2	0.62	PAFG102/90X-B	348	348
1 1/4	32	1 5/16-12	21.5	25	22	84	80	30.2	58.7	56	11.5	M10 35	3/8 1 1/2	1.06	PAFG104/90X-A	278	278
1 1/4	32	1 5/8-12	27.5	31	22	84	80	30.2	58.7	58	11.5	M10 35	7/16 1 1/2	0.93	PAFG104/90X-B	278	278
1 1/4	32	1 7/8-12	33.0	37	22	84	80	30.2	58.7	61	11.5	M10 35	7/16 1 1/2	0.96	PAFG104/90X-C	278	278
1 1/2	38	1 5/8-12	27.5	31	25	88	94	35.7	69.9	63	13.5	M10 40	7/16 1 1/2	1.44	PAFG106/90X-A	210	210
1 1/2	38	1 7/8-12	33.0	37	25	88	94	35.7	69.9	66	13.5	M12 45	1/2 1 3/4	1.35	PAFG106/90X-B	210	210

6000 PSI Series

1/2	13	3/4-16	9.9	17	16	60	57	18.2	40.5	40	9.0	M 8 30	5/16 1 1/4	0.30	PAFG401/90X-A	350	350
1/2	13	7/8-14	12.3	17	16	60	57	18.2	40.5	42	9.0	M 8 30	5/16 1 1/4	0.32	PAFG401/90X-B	350	350
1/2	13	1 1/16-12	12.3	20	16	60	57	18.2	40.5	43	9.0	M 8 30	5/16 1 1/4	0.35	PAFG401/90X-C	350	350
3/4	19	7/8-14	12.3	20	19	68	71	23.8	50.8	49	11.0	M10 35	3/8 1 1/2	0.53	PAFG402/90X-A	350	350
3/4	19	1 1/16-12	15.5	20	19	68	71	23.8	50.8	51	11.0	M10 35	3/8 1 1/2	0.53	PAFG402/90X-B	350	350
3/4	19	1 5/16-12	21.5	25	19	68	71	23.8	50.8	52	11.0	M10 35	3/8 1 1/2	0.53	PAFG402/90X-C	350	350
1	25	1 1/16-12	15.5	25	24	83	80	27.8	57.2	55	13.0	M12 45	7/16 1 1/2	0.90	PAFG403/90X-A	350	350
1	25	1 5/16-12	21.5	25	24	83	80	27.8	57.2	56	13.0	M12 45	7/16 1 1/2	0.90	PAFG403/90X-B	350	350
1	25	1 5/8-12	27.5	31	24	83	80	27.8	57.2	58	13.0	M12 45	7/16 1 1/2	0.90	PAFG403/90X-C	275	275
1 1/4	32	1 5/16-12	21.5	31	25	97	94	31.8	66.6	56	15.0	M14 45	1/2 1 3/4	1.35	PAFG404/90X-A	350	350
1 1/4	32	1 5/8-12	27.5	31	25	97	94	31.8	66.6	63	15.0	M14 45	1/2 1 3/4	1.40	PAFG404/90X-B	275	275
1 1/4	32	1 7/8-12	33.0	37	25	97	94	31.8	66.6	63	15.0	M14 45	1/2 1 3/4	1.45	PAFG404/90X-C	210	210
1 1/2	38	1 5/8-12	27.5	37	26	110	106	36.5	79.3	67	17.0	M16 50	5/8 2	1.80	PAFG405/90X-A	275	275
1 1/2	38	1 7/8-12	33.0	37	26	110	106	36.5	79.3	70	17.0	M16 50	5/8 2	1.85	PAFG405/90X-B	210	210

1) Pressure shown = Item deliverable

$$\frac{PN \text{ (bar)}}{10} = PN \text{ (MPa)}$$

*Please add the suffixes below according to the material / surface required.

Order code suffixes					
Material	Suffix surface and material	Example only 4 bolt flange	Example 4 bolt flange incl. metr. screws and O-ring	Example 4 bolt flange incl. UNC screws and O-ring	Standard sealing material (no additional suffix needed)
Steel, zinc plated, chrome ⁶ -free	CF	PAFG080/90X-ACF	PAFG080/90X-ACFM	PAFG080/90X-ACFU	NBR
Steel, zinc yellow plated	A3C	PAFG080/90X-AA3C	PAFG080/90X-AA3CM	PAFG080/90X-AA3CU	NBR
Stainless steel	SS	PAFG080/90X-ASS	PAFG080/90X-ASSM	PAFG080/90X-ASSU	VIT



PAFG-L SAE Straight 4 bolt flange with O-Lok® ORFS end

SAE Flange / O-Lok® ORFS end
(ISO 6162-1/-2)

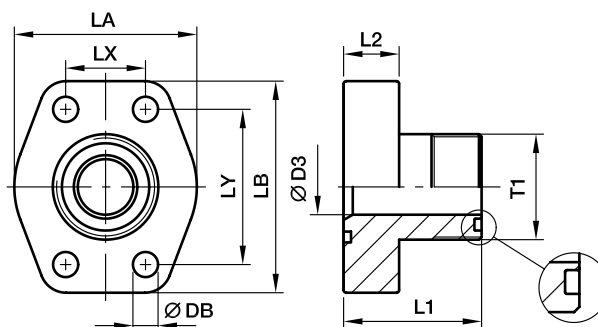

3000 PSI Series

Nom. flange size		T1	D3	L1	L2	LA	LB	LX	LY	DB	Screws		Weight (steel) kg/piece	Order code*	PN (bar) ¹⁾	
SAE (in)	ISO (DN)										(metr.)	(unc.)			A3C	SS
1/2	13	11/16-16UN-2A	6	37	16	47	56	17.5	38.1	9.0	M 8 30	5/16 1 1/4	0.24	PAFG080L-A	348	348
1/2	13	13/16-16UN-2A	9	39	16	47	56	17.5	38.1	9.0	M 8 30	5/16 1 1/4	0.25	PAFG080L-B	348	348
1/2	13	1-14UN-2A	12	42	16	47	56	17.5	38.1	9.0	M 8 30	5/16 1 1/4	0.27	PAFG080L-C	348	348
3/4	19	1-14UN-2A	12	45	18	50	66	22.3	47.6	11.0	M10 35	3/8 1 1/2	0.44	PAFG100L-A	348	348
3/4	19	1 3/16-12UN-2A	15	47	18	50	66	22.3	47.6	11.0	M10 35	3/8 1 1/2	0.46	PAFG100L-B	348	348
1	25	1 3/16-12UN-2A	15	49	18	53	71	26.2	52.4	11.0	M10 35	3/8 1 1/2	0.53	PAFG102L-A	348	348
1	25	1 7/16-12UN-2A	20	49	18	53	71	26.2	52.4	11.0	M10 35	3/8 1 1/2	0.52	PAFG102L-B	348	348
1 1/4	32	1 7/16-12UN-2A	20	53	21	69	80	30.2	58.7	11.5	M10 35	7/16 1 1/2	0.75	PAFG104L-A	278	278
1 1/4	32	1 11/16-12UN-2A	26	53	21	69	80	30.2	58.7	11.5	M10 35	7/16 1 1/2	0.78	PAFG104L-B	278	278
1 1/2	38	1 11/16-12UN-2A	26	61	24	77	94	35.7	69.9	13.5	M12 45	1/2 1 3/4	1.20	PAFG106L-A	210	210
1 1/2	38	2-12UN-2A	32	61	24	77	94	35.7	69.9	13.5	M12 45	1/2 1 3/4	1.25	PAFG106L-B	210	210

6000 PSI Series

1/2	13	11/16-16UN-2A	6	38	16	47	57	18.2	40.5	9.0	M 8 30	5/16 1 1/4	0.25	PAFG401L-A	420	420
1/2	13	13/16-16UN-2A	9	40	16	47	57	18.2	40.5	9.0	M 8 30	5/16 1 1/4	0.27	PAFG401L-B	420	420
1/2	13	1-14UN-2A	12	43	16	47	57	18.2	40.5	9.0	M 8 30	5/16 1 1/4	0.31	PAFG401L-C	420	420
3/4	19	1-14UN-2A	12	47	18	53	71	23.8	50.8	11.0	M10 35	3/8 1 1/2	0.56	PAFG402L-A	420	420
3/4	19	1 3/16-12UN-2A	15	49	18	53	71	23.8	50.8	11.0	M10 35	3/8 1 1/2	0.65	PAFG402L-B	420	420
1	25	1 3/16-12UN-2A	15	56	21	66	80	27.8	57.2	13.0	M12 45	7/16 1 1/2	0.62	PAFG403L-A	420	420
1	25	1 7/16-12UN-2A	20	56	21	66	80	27.8	57.2	13.0	M12 45	7/16 1 1/2	0.66	PAFG403L-B	420	420
1 1/4	32	1 7/16-12UN-2A	20	61	24	78	94	31.8	66.6	15.0	M14 45	1/2 1 3/4	0.95	PAFG404L-A	345	345
1 1/4	32	1 11/16-12UN-2A	26	61	24	78	94	31.8	66.6	15.0	M14 45	1/2 1 3/4	1.08	PAFG404L-B	345	345
1 1/2	38	1 11/16-12UN-2A	26	65	27	90	106	36.5	79.3	17.0	M16 50	5/8 2	1.66	PAFG405L-A	310	310
1 1/2	38	2-12UN-2A	32	67	27	90	106	36.5	79.3	17.0	M16 50	5/8 2	1.75	PAFG405L-B	310	310

1) Pressure shown = Item deliverable

$$\frac{PN(\text{bar})}{10} = PN(\text{MPa})$$

*Please add the suffixes below according to the material / surface required.

Order code suffixes					
Material	Suffix surface and material	Example only 4 bolt flange	Example 4 bolt flange incl. metr. screws and O-ring	Example 4 bolt flange incl. UNC screws and O-ring	Standard sealing material (no additional suffix needed)
Steel, zinc plated, chrome ⁶ -free	CF	PAFG080L-ACF	PAFG080L-ACFM	PAFG080L-ACFU	NBR
Steel, zinc yellow plated	A3C	PAFG080L-AA3C	PAFG080L-AA3CM	PAFG080L-AA3CU	NBR
Stainless steel	SS	PAFG080L-ASS	PAFG080L-ASSM	PAFG080L-ASSU	VIT

PAFG-90L SAE 90° 4 bolt flange with O-Lok® ORFS end

SAE 90° Flange / O-Lok® ORFS end
(ISO 6162-1/-2)

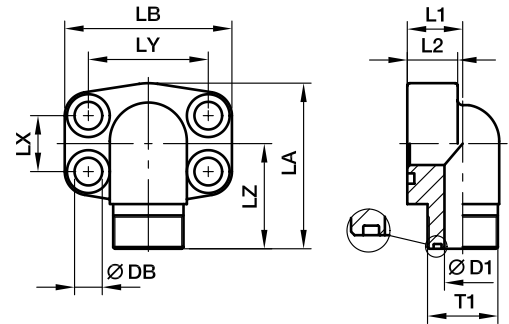

3000 PSI Series

Nom. flange size		T1	D1	L1	L2	LA	LB	LX	LY	LZ	DB	Screws		Weight (steel) kg/piece	Order code*	PN (bar) ¹⁾	
SAE (in)	ISO (DN)											(metr.)	(unc.)			A3C	SS
1/2	13	11/16-16UN-2A	6	17	16	60	56	17.5	38.1	37	9.0	M 8 30	5/16 1 1/4	0.26	PAFG080/90L-A	348	348
1/2	13	13/16-16UN-2A	9	17	16	60	56	17.5	38.1	39	9.0	M 8 30	5/16 1 1/4	0.29	PAFG080/90L-B	348	348
1/2	13	1-14UN-2A	12	20	16	60	56	17.5	38.1	40	9.0	M 8 30	5/16 1 1/4	0.31	PAFG080/90L-C	348	348
3/4	19	1-14UN-2A	12	20	18	63	66	22.3	47.6	44	11.0	M10 35	3/8 1 1/2	0.63	PAFG100/90L-A	348	348
3/4	19	1 3/16-12UN-2A	15	25	18	63	66	22.3	47.6	45	11.0	M10 35	3/8 1 1/2	0.64	PAFG100/90L-B	348	348
1	25	1 3/16-12UN-2A	15	25	19	80	71	26.2	52.4	48	11.0	M10 35	3/8 1 1/2	0.63	PAFG102/90L-A	348	348
1	25	1 7/16-12UN-2A	20	31	19	80	71	26.2	52.4	49	11.0	M10 35	3/8 1 1/2	0.66	PAFG102/90L-B	348	348
1 1/4	32	1 7/16-12UN-2A	20	31	22	84	80	30.2	58.7	55	11.5	M10 35	7/16 1 1/2	1.02	PAFG104/90L-A	278	278
1 1/4	32	1 11/16-12UN-2A	26	31	22	84	80	30.2	58.7	55	11.5	M10 35	7/16 1 1/2	1.08	PAFG104/90L-B	278	278
1 1/2	38	1 11/16-12UN-2A	26	31	25	88	94	35.7	69.9	59	13.5	M12 45	1/2 1 3/4	1.66	PAFG106/90L-A	210	210
1 1/2	38	2-12UN-2A	32	37	25	88	94	35.7	69.9	61	13.5	M12 45	1/2 1 3/4	1.68	PAFG106/90L-B	210	210

6000 PSI Series

1/2	13	11/16-16UN-2A	16	17	16	60	57	18.2	40.5	37	9.0	M 8 30	5/16 1 1/4	0.27	PAFG401/90L-A	420	420
1/2	13	13/16-16UN-2A	16	17	16	60	57	18.2	40.5	39	9.0	M 8 30	5/16 1 1/4	0.30	PAFG401/90L-B	420	420
1/2	13	1-14UN-2A	16	20	16	60	57	18.2	40.5	40	9.0	M 8 30	5/16 1 1/4	0.32	PAFG401/90L-C	420	420
3/4	19	1-14UN-2A	19	20	19	68	71	23.8	50.8	48	11.0	M10 35	3/8 1 1/2	0.64	PAFG402/90L-A	420	420
3/4	19	1 3/16-12UN-2A	19	25	19	68	71	23.8	50.8	50	11.0	M10 35	3/8 1 1/2	0.65	PAFG402/90L-B	420	420
1	25	1 3/16-12UN-2A	24	25	24	83	80	27.8	57.2	54	13.0	M12 45	7/16 1 1/2	0.64	PAFG403/90L-A	420	420
1	25	1 7/16-12UN-2A	24	31	24	83	80	27.8	57.2	55	13.0	M12 45	7/16 1 1/2	0.67	PAFG403/90L-B	420	420
1 1/4	32	1 7/16-12UN-2A	25	31	25	97	94	31.8	66.6	59	15.0	M14 45	1/2 1 3/4	1.04	PAFG404/90L-A	420	420
1 1/4	32	1 11/16-12UN-2A	25	31	25	97	94	31.8	66.6	59	15.0	M14 45	1/2 1 3/4	1.10	PAFG404/90L-B	345	345
1 1/2	38	1 11/16-12UN-2A	26	37	26	110	106	36.5	79.3	64	17.0	M16 50	5/8 2	1.69	PAFG405/90L-A	345	345
1 1/2	38	2-12UN-2A	26	37	26	110	106	36.5	79.3	66	17.0	M16 50	5/8 2	1.71	PAFG405/90L-B	310	310

1) Pressure shown = Item deliverable

$$\frac{\text{PN (bar)}}{10} = \text{PN (MPa)}$$

*Please add the suffixes below according to the material / surface required.

Order code suffixes					
Material	Suffix surface and material	Example only 4 bolt flange	Example 4 bolt flange incl. metr. screws and O-ring	Example 4 bolt flange incl. UNC screws and O-ring	Standard sealing material (no additional suffix needed)
Steel, zinc plated, chrome ⁶ -free	CF	PAFG080/90L-ACF	PAFG080/90L-ACFM	PAFG080/90L-ACFU	NBR
Steel, zinc yellow plated	A3C	PAFG080/90L-AA3C	PAFG080/90L-AA3CM	PAFG080/90L-AA3CU	NBR
Stainless steel	SS	PAFG080/90L-ASS	PAFG080/90L-ASSM	PAFG080/90L-ASSU	VIT



PAFS-B SAE Straight 4 bolt flange (butt weld)

SAE Flange / Butt weld tube end
(ISO 6162-1/-2)

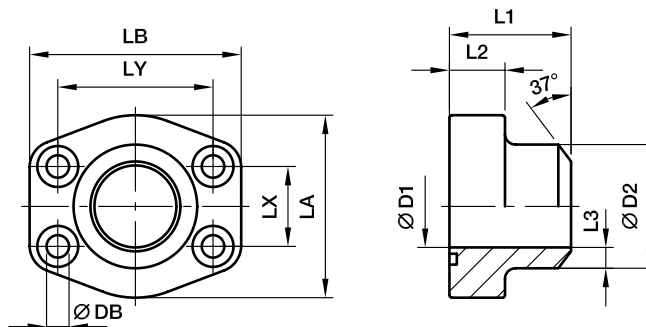

3000 PSI Series

Nom. flange size		max.											Screws		Weight (steel) kg/piece	Order code*	PN (bar) ¹⁾	
SAE (in)	ISO (DN)		D1	D2	L1	L2	L3	LA	LB	LX	LY	DB	(metr.)	(unc.)			S	SS
1/2	13	21.3	13	21.6	36	16	4.3	46	58	17.5	38.1	9.0	M 8 30	5/16 1 1/4	0.28	PAFS080B	345	345
3/4	19	26.9	19	27.2	36	18	4.1	49	66	22.3	47.6	10.5	M10 35	3/8 1 1/2	0.39	PAFS100B	345	345
1	25	33.7	25	34.5	38	18	4.7	53	71	26.2	52.4	10.5	M10 35	3/8 1 1/2	0.46	PAFS102B	345	345
1 1/4	32	42.4	31	42.8	41	21	3.0	69	80	30.2	58.7	10.5	M10 40	7/16 1 1/2	0.66	PAFS104B	276	276
1 1/2	38	48.3	38	48.6	44	25	5.3	77	94	35.7	69.9	13.5	M12 45	1/2 1 3/4	1.05	PAFS106B	207	207
2	51	60.3	50	61.0	45	25	5.5	89	103	42.9	77.8	13.5	M12 45	1/2 1 3/4	1.19	PAFS108B	207	207
2 1/2	64	76.1	63	76.6	50	25	6.8	101	115	50.8	88.9	13.5	M12 45	1/2 1 3/4	1.40	PAFS110B	172	172
3	76	88.9	73	89.0	50	27	8.0	124	135	61.9	106.4	17.0	M16 50	5/8 2	2.15	PAFS112B	138	138
3 1/2	89	101.6	89	103.0	50	27	7.0	134	153	69.9	120.7	17.0	M16 50	5/8 2	2.40	PAFS114B	34	34
4	102	114.3	99	115.0	50	27	8.0	147	163	77.8	130.2	17.0	M16 50	5/8 2	2.85	PAFS116B	34	34
5	127	140.0	120	141.0	50	28	10.5	180	184	92.1	152.4	17.0	M16 50	5/8 2	4.85	PAFS118B	34	34

6000 PSI Series

1/2	13	17.2	10	17.5	36	18	3.7	46	58	18.2	40.5	9.0	M 8 30	5/16 1 1/4	0.26	PAFS401B38	420	420
1/2	13	21.3	13	21.6	36	18	4.3	46	58	18.2	40.5	9.0	M 8 30	5/16 1 1/4	0.29	PAFS401B	420	420
3/4	19	26.9	18	27.2	36	18	4.6	53	71	23.8	50.8	10.5	M10 35	3/8 1 1/2	0.50	PAFS402B	420	420
1	25	33.7	22	34.5	44	24	6.3	66	80	27.8	57.2	10.5	M12 45	1/2 1 3/4	0.76	PAFS403B	420	420
1 1/4	32	42.4	28	42.8	44	25	7.4	77	94	31.8	66.6	15.0	M14 45	1/2 1 3/4	1.35	PAFS404B	420	420
1 1/2	38	48.3	32	48.6	51	29	8.3	89	106	36.5	79.3	17.0	M16 50	5/8 2	1.80	PAFS405B	420	420
2	51	60.3	41	61.0	70	35	10.0	116	135	44.5	96.8	21.0	M20 65	3/4 2 1/2	2.45	PAFS406B	420	420
2 1/2	64	76.1	50	76.6	75	45	13.0	150	166	58.7	123.8	25.0	M24 85	-	6.25	PAFS407B	420	420
3	76	88.9	58	90.0	90	55	16.0	178	208	71.4	152.4	32.0	M30 110	-	8.10	PAFS408B	420	420

1) Pressure shown = Item deliverable

$$\frac{\text{PN (bar)}}{10} = \text{PN (MPa)}$$

The pressures given here are the maximum allowable for the flange fittings. If the pipe or tube used has a lower pressure rating, then the welded assembly rating will be the lower one, assuming the weld is adequately strong.

*Please add the suffixes below according to the material / surface required.

Order code suffixes					
Material	Suffix surface and material	Example only 4 bolt flange	Example 4 bolt flange incl. metr. screws and O-ring	Example 4 bolt flange incl. UNC screws and O-ring	Standard sealing material (no additional suffix needed)
Steel, blanc oil dipped	S	PAFS080BS	PAFS080BSM	PAFS080BSU	NBR
Stainless steel	SS	PAFS080BSS	PAFS080BSSM	PAFS080BSSU	VIT

PGFS-B SAE Straight 4 bolt counter flange (butt weld)

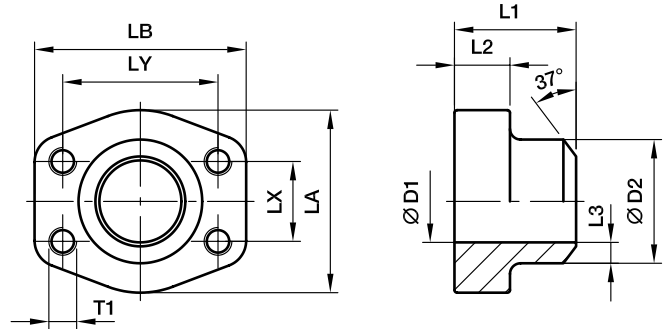
 SAE Counter flange / Butt weld tube end
 (ISO 6162-1/-2)

3000 PSI Series

Nom. flange size		Ø max.											T1		Weight (steel) kg/piece	Order code*	PN (bar) ¹⁾	
SAE (in)	ISO (DN)		D1	D2	L1	L2	L3	LA	LB	LX	LY	(metr.)	(unc.)	S			SS	
1/2	13	21.3	13	21.6	36	16	4.3	47	57	17.5	38.1	M 8	5/16	0.25	PGFS080B	345	345	
3/4	19	26.9	19	27.2	36	18	4.1	49	66	22.3	47.6	M10	3/8	0.35	PGFS100B	345	345	
1	25	33.7	25	34.5	38	18	4.7	53	71	26.2	52.4	M10	3/8	0.46	PGFS102B	345	345	
1 1/4	32	42.4	31	42.8	41	21	6.0	69	80	30.2	58.7	M10	7/16	0.66	PGFS104B	276	276	
1 1/2	38	48.3	38	48.6	44	25	5.3	77	94	35.7	69.9	M12	1/2	1.05	PGFS106B	207	207	
2	51	60.3	50	61.0	45	25	5.5	89	103	42.9	77.8	M12	1/2	1.19	PGFS108B	207	207	
2 1/2	64	76.1	63	76.6	50	25	6.8	101	115	50.8	88.9	M12	1/2	1.40	PGFS110B	172	172	
3	76	88.9	73	89.0	50	27	8.0	124	135	61.9	106.4	M16	5/8	2.15	PGFS112B	138	138	
3 1/2	89	101.6	89	103.0	50	27	7.0	134	153	69.9	120.7	M16	5/8	2.40	PGFS114B	34	34	
4	102	114.3	99	115.0	50	27	8.0	147	163	77.8	130.2	M16	5/8	2.85	PGFS116B	34	34	
5	127	140.0	120	141.0	50	28	10.5	180	184	92.1	152.4	M16	5/8	4.90	PGFS118B	34	34	

6000 PSI Series

1/2	13	17.2	10	17.5	36	16	3.7	47	57	18.2	40.5	M 8	5/16	0.29	PGFS401B38	420	420
1/2	13	21.3	13	21.6	36	16	4.3	47	57	18.2	40.5	M 8	5/16	0.26	PGFS401B	420	420
3/4	19	26.9	18	27.2	36	19	4.6	53	71	23.8	50.8	M10	3/8	0.50	PGFS402B	420	420
1	25	33.7	22	34.5	44	24	6.3	66	80	27.8	57.2	M12	7/16	0.76	PGFS403B	420	420
1 1/4	32	42.4	28	42.8	44	27	7.4	77	94	31.8	66.6	M14	1/2	1.20	PGFS404B	420	420
1 1/2	38	48.3	32	48.6	51	30	8.3	89	106	36.5	79.3	M16	5/8	1.65	PGFS405B	420	420
2	51	60.3	41	61.0	70	37	10.0	116	135	44.5	96.8	M20	3/4	2.75	PGFS406B	420	420
2 1/2	64	76.1	50	76.6	75	45	13.0	150	166	58.7	123.8	M24	-	6.40	PGFS407B	420	420
3	76	88.9	58	90.0	90	55	16.0	178	208	71.4	152.4	M30	-	8.25	PGFS408B	420	420

1) Pressure shown = Item deliverable

$$\frac{PN \text{ (bar)}}{10} = PN \text{ (MPa)}$$

The pressures given here are the maximum allowable for the flange fittings. If the pipe or tube used has a lower pressure rating, then the welded assembly rating will be the lower one, assuming the weld is adequately strong.

*Please add the suffixes below according to the material / surface required.

Order code suffixes				
Material	Suffix surface and material	Example 4 bolt flange with metr. threads	Example 4 bolt flange with UNC threads	Standard sealing material (no additional suffix needed)
Steel, blanc oil dipped	S	PGFS080BSM	PGFS080BSU	NBR
Stainless steel	SS	PGFS080BSSM	PGFS080BSSU	VIT

PAFS-90B SAE 90° 4 bolt flange (butt weld)

SAE 90° Flange / Butt weld tube end
(ISO 6162-1/-2)

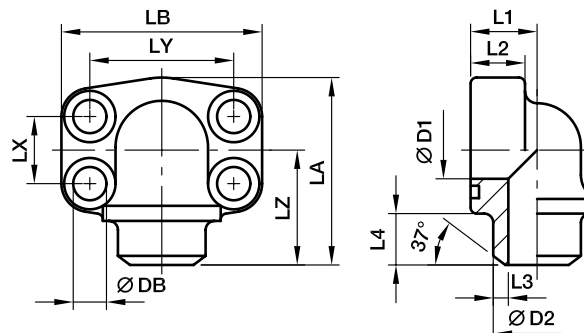

3000 PSI Series

Nom. flange size		max.														Screws		Weight (steel) kg/piece	PN (bar) ¹⁾	
SAE (in)	ISO (DN)		D1	D2	L1	L2	L3	L4	LA	LB	LX	LY	LZ	DB	(metr.)	(unc.)	Order code*		S	SS
1/2	13	21.3	13	21.6	18	16	4.3	12	63	56	17.5	38.1	40	9.0	M 8 30	5/16 1 1/4	0.45	PAFS080/90B	345	345
3/4	19	26.9	19	27.2	22	18	4.1	12	74	68	22.3	47.6	41	10.5	M10 35	3/8 1 1/2	0.65	PAFS100/90B	345	345
1	25	33.7	25	34.5	28	19	4.7	13	77	74	26.2	52.4	50	10.5	M10 35	3/8 1 1/2	0.85	PAFS102/90B	345	345
1 1/4	32	42.4	31	42.8	30	22	6.0	13	91	81	30.2	58.7	57	10.5	M10 40	7/16 1 1/2	1.15	PAFS104/90B	276	276
1 1/2	38	48.3	38	48.6	36	25	5.3	14	105	95	35.7	69.9	66	13.5	M12 45	1/2 1 3/4	1.70	PAFS106/90B	207	207
2	51	60.3	50	61.0	41	25	5.5	15	110	105	42.9	77.8	66	13.5	M12 45	1/2 1 3/4	2.15	PAFS108/90B	207	207
2 1/2	64	76.1	60	76.6	50	25	8.0	25	127	115	50.8	88.9	77	13.5	M12 45	1/2 1 3/4	2.95	PAFS110/90B	172	172

6000 PSI Series

1/2	13	21.3	13	21.6	18	16	4.3	12	23	56	18.2	40.5	40	9.0	M 8 30	5/16 1 1/4	0.50	PAFS401/90B	420	420
3/4	19	26.9	18	27.2	28	20	4.6	12	27	72	23.8	50.8	50	10.5	M10 35	3/8 1 1/2	0.55	PAFS402/90B	420	420
1	25	33.7	22	34.5	26	24	6.3	13	34	82	27.8	57.2	57	13.5	M12 45	1/2 1 3/4	0.80	PAFS403/90B	420	420
1 1/4	32	42.4	28	42.8	36	25	7.4	13	39	95	31.8	66.6	66	15.0	M14 45	1/2 1 3/4	1.15	PAFS404/90B	420	420
1 1/2	38	48.3	32	48.6	41	26	8.3	15	44	110	36.5	79.3	65	17.0	M16 50	5/8 2	2.00	PAFS405/90B	420	420
2	51	60.3	41	61.0	45	35	10.0	15	58	134	44.5	96.8	75	21.0	M20 65	3/4 2 1/2	3.00	PAFS406/90B	420	420

¹⁾ Pressure shown = Item deliverable

$$\frac{\text{PN (bar)}}{10} = \text{PN (MPa)}$$

The pressures given here are the maximum allowable for the flange fittings. If the pipe or tube used has a lower pressure rating, then the welded assembly rating will be the lower one, assuming the weld is adequately strong.

*Please add the suffixes below according to the material / surface required.

Order code suffixes					
Material	Suffix surface and material	Example only 4 bolt flange	Example 4 bolt flange incl. metr. screws and O-ring	Example 4 bolt flange incl. UNC screws and O-ring	Standard sealing material (no additional suffix needed)
Steel, blanc oil dipped	S	PAFS080/90BS	PAFS080/90BSM	PAFS080/90BSU	NBR
Stainless steel	SS	PAFS080/90BSS	PAFS080/90BSSM	PAFS080/90BSSU	VIT

PAFS-S SAE Straight 4 bolt flange (socket weld)

SAE Flange / Socket weld tube end
(ISO 6162-1/-2)

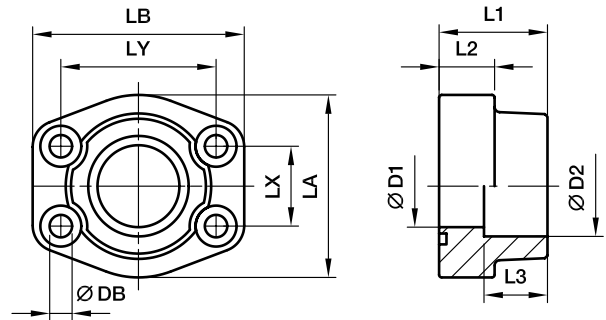

3000 PSI Series

Nom. flange size		max.											Screws		Weight (steel) kg/piece	Order code*	PN (bar) ¹⁾	
SAE (in)	ISO (DN)		D1	D2	L1	L2	L3	LA	LB	LX	LY	DB	(metr.)	(unc.)			S	SS
1/2	13	17.2	13	17.5	36	16	18	46	58	17.5	38.1	9.0	M 8 30	5/16 1 1/4	0.25	PAFS080S17.5	345	345
1/2	13	21.3	13	21.6	36	16	18	46	58	17.5	38.1	9.0	M 8 30	5/16 1 1/4	0.28	PAFS080S21.6	345	345
3/4	19	26.9	19	27.2	36	18	18	49	66	22.3	47.6	10.5	M10 35	3/8 1 1/2	0.39	PAFS100S27.2	345	345
1	25	33.7	25	34.1	38	18	18	53	70	26.2	52.4	10.3	M10 35	3/8 1 1/2	0.46	PAFS102S34.1	345	345
1 1/4	32	42.4	31	42.8	41	21	20	69	80	30.2	58.7	10.5	M10 40	7/16 1 1/2	0.66	PAFS104S42.8	276	276
1 1/2	38	48.3	38	48.6	44	25	22	77	94	35.7	59.9	13.5	M12 45	1/2 1 3/4	1.05	PAFS106S48.6	207	207
2	51	60.3	50	61.0	45	25	24	89	103	42.9	77.8	13.5	M12 45	1/2 1 3/4	1.19	PAFS108S61	207	207
2 1/2	64	76.1	63	76.6	50	25	28	101	115	50.8	88.9	13.5	M12 45	1/2 1 3/4	1.40	PAFS110S76.6	172	172
3	76	88.9	73	90.5	50	27	28	124	135	61.9	106.4	17.0	M16 50	5/8 2	2.15	PAFS112S90.5	138	138
3 1/2	89	101.6	89	103.0	50	27	28	137	153	69.9	120.7	17.0	M16 50	5/8 2	2.40	PAFS114S103	34	34
4	102	114.3	99	115.5	50	27	28	147	163	77.8	130.2	17.0	M16 50	5/8 2	2.85	PAFS116S115.5	34	34
5	127	140.0	120	142.0	50	28	28	180	184	92.1	152.4	17.0	M16 50	5/8 2	3.25	PAFS118S142	34	34

6000 PSI Series

1/2	13	17.2	13	17.5	36	16	18	46	58	18.2	40.5	9.0	M 8 30	5/16 1 1/4	0.26	PAFS401S17.5	420	420
1/2	13	21.3	13	21.6	36	16	18	46	58	18.2	40.5	9.0	M 8 30	5/16 1 1/4	0.29	PAFS401S21.6	420	420
3/4	19	26.9	19	27.2	36	19	20	53	71	23.8	50.8	10.3	M10 35	3/8 1 1/2	0.50	PAFS402S27.2	420	420
1	25	33.7	25	34.1	44	24	22	66	80	27.8	57.2	13.5	M12 45	1/2 1 3/4	0.76	PAFS403S34.1	420	420
1 1/4	32	42.4	31	42.8	44	27	22	77	94	31.8	66.6	15.0	M14 45	1/2 1 3/4	1.20	PAFS404S42.8	420	420
1 1/2	38	48.3	38	48.6	51	30	24	89	106	36.5	79.3	17.0	M16 50	5/8 2	1.65	PAFS405S48.6	420	420
2	51	60.3	50	61.0	70	37	25	116	135	44.5	96.8	21.0	M20 65	3/4 2 1/2	2.45	PAFS406S61	420	420
2 1/2	64	76.1	63	76.6	75	45	28	150	166	58.7	123.8	25.0	M24 85	-	3.05	PAFS407S76.6	420	420
3	76	88.9	73	90.5	90	55	30	178	208	71.4	152.4	32.0	M30 110	-	3.45	PAFS408S90.5	420	420

¹⁾ Pressure shown = Item deliverable

$$\frac{PN \text{ (bar)}}{10} = PN \text{ (MPa)}$$

The pressures given here are the maximum allowable for the flange fittings. If the pipe or tube used has a lower pressure rating, then the welded assembly rating will be the lower one, assuming the weld is adequately strong.

*Please add the suffixes below according to the material / surface required.

Order code suffixes					
Material	Suffix surface and material	Example only 4 bolt flange	Example 4 bolt flange incl. metr. screws and O-ring	Example 4 bolt flange incl. UNC screws and O-ring	Standard sealing material (no additional suffix needed)
Steel, blanc oil dipped	S	PAFS080S17.5S	PAFS080S17.5SM	PAFS080S17.5SU	NBR
Stainless steel	SS	PAFS080S17.5SS	PAFS080S17.5SSM	PAFS080S17.5SSU	VIT



PGFS-S SAE Straight counter 4 bolt flange (socket weld)

SAE Counter flange / Socket weld tube end
(ISO 6162-1/-2)

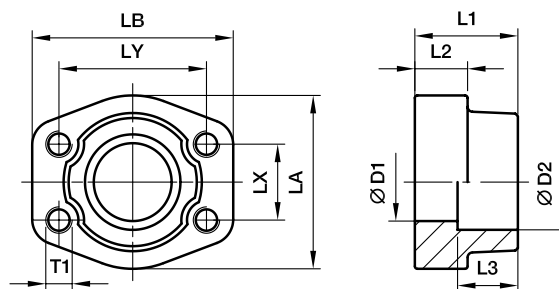

3000 PSI Series

Nom. flange size		max.	D1	D2	L1	L2	L3	LA	LB	LX	LY	DB	T1		Weight (steel) kg/piece	Order code*	PN (bar) ¹⁾	
SAE (in)	ISO (DN)												(metr.)	(unc.)			S	SS
1/2	13	17.2	13	17.5	36	18	16	46	58	17.5	38.1	9.0	M 8	5/16	0.25	PGFS080S17.5	345	345
1/2	13	21.3	13	21.6	36	18	16	46	58	17.5	38.1	9.0	M 8	5/16	0.28	PGFS080S21.6	345	345
3/4	19	26.9	19	27.2	36	18	18	49	66	22.3	47.6	10.5	M10	3/8	0.39	PGFS100S27.2	345	345
1	25	33.7	25	34.1	38	18	18	53	70	26.2	52.4	10.5	M10	3/8	0.46	PGFS102S34.1	345	345
1 1/4	32	42.4	31	42.8	41	20	21	69	80	30.2	58.7	10.5	M10	7/16	0.66	PGFS104S42.8	276	276
1 1/2	38	48.3	38	48.6	44	22	25	77	94	35.7	69.9	13.5	M12	1/2	1.05	PGFS106S48.6	207	207
2	51	60.3	50	61.0	45	24	25	89	103	42.9	77.8	13.5	M12	1/2	1.19	PGFS108S61	207	207
2 1/2	64	76.1	63	76.6	50	28	25	101	115	50.8	88.9	13.5	M12	1/2	1.40	PGFS110S76.6	172	172
3	76	88.9	73	90.5	50	28	27	124	135	61.9	106.4	17.0	M16	5/8	2.15	PGFS112S90.5	138	138
3 1/2	89	101.6	89	103.0	50	28	27	137	153	69.9	120.7	17.0	M16	5/8	2.40	PGFS114S103	34	34
4	102	114.3	99	115.5	50	28	27	147	163	77.8	130.2	17.0	M16	5/8	2.85	PGFS116S115.5	34	34
5	127	140.0	120	142.0	50	28	28	180	184	92.1	152.4	17.0	M16	5/8	3.25	PGFS118S142	34	34

6000 PSI Series

1/2	13	17.2	13	17.5	36	18	16	46	58	18.2	40.5	9.0	M 8	5/16	0.26	PGFS401S17.5	420	420
1/2	13	21.3	13	21.6	36	18	16	46	58	18.2	40.5	9.0	M 8	5/16	0.29	PGFS401S21.6	420	420
3/4	19	26.9	19	27.2	36	20	19	53	71	23.8	50.8	10.5	M10	3/8	0.50	PGFS402S27.2	420	420
1	25	33.7	25	34.1	44	22	24	66	80	27.8	57.2	13.5	M12	7/16	0.76	PGFS403S34.1	420	420
1 1/4	32	42.4	31	42.8	44	22	27	77	94	31.8	66.6	15.0	M14	1/2	1.20	PGFS404S42.8	420	420
1 1/2	38	48.3	38	48.6	51	24	30	89	106	36.5	79.3	17.0	M16	5/8	1.65	PGFS405S48.6	420	420
2	51	60.3	50	61.0	70	25	37	116	135	44.5	96.8	21.0	M20	3/4	2.45	PGFS406S61	420	420
2 1/2	64	76.1	63	76.6	75	28	45	150	166	58.7	123.8	25.0	M24	-	3.05	PGFS407S76.6	420	420
3	76	88.9	73	90.5	90	30	55	178	208	71.4	152.4	32.0	M30	-	3.45	PGFS408S90.5	420	420

1) Pressure shown = Item deliverable

$$\frac{\text{PN (bar)}}{10} = \text{PN (MPa)}$$

The pressures given here are the maximum allowable for the flange fittings. If the pipe or tube used has a lower pressure rating, then the welded assembly rating will be the lower one, assuming the weld is adequately strong.

*Please add the suffixes below according to the material / surface required.

Order code suffixes				
Material	Suffix surface and material	Example 4 bolt flange with metr. threads	Example 4 bolt flange with UNC threads	Standard sealing material (no additional suffix needed)
Steel, blanc oil dipped	S	PGFS080S17.5SM	PGFS080S17.5SU	NBR
Stainless steel	SS	PGFS080S17.5SSM	PGFS080S17.5SSU	VIT

PAFSF-S SAE Straight 4 bolt flange flat (socket weld)

 SAE Flange / Socket weld tube end
 (ISO 6162-1/-2)

only for low pressure applications

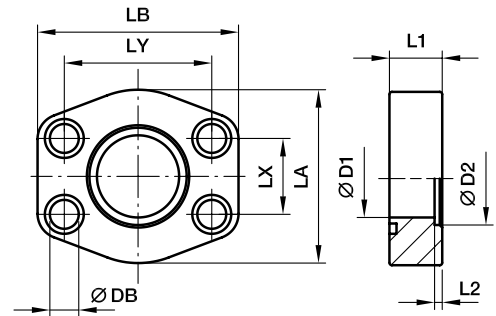
3000 PSI Series

Nom. flange size		max.	D1	D2	L1	L2	LA	LB	LX	LY	DB	Screws		Weight (steel) kg/piece	Order code*	PN (bar) ¹⁾	
SAE (in)	ISO (DN)											(metr.)	(unc.)			S	SS
1/2	13	17.2	13	17.5	16	3	46	58	17.5	38.1	9.0	M 8 30	5/16 1 1/4	0.12	PAFSF080S17.5	40	40
1/2	13	21.3	13	21.6	16	3	46	58	17.5	38.1	9.0	M 8 30	5/16 1 1/4	0.12	PAFSF080S21.6	40	40
3/4	19	21.3	13	21.6	18	4	49	66	22.3	47.6	10.5	M10 35	3/8 1 1/2	0.20	PAFSF100S21.6	40	40
3/4	19	26.9	19	27.2	18	4	49	66	22.3	47.6	10.5	M10 35	3/8 1 1/2	0.20	PAFSF100S27.2	40	40
1	25	26.9	19	27.2	19	4	53	71	26.2	52.4	10.5	M10 35	3/8 1 1/2	0.25	PAFSF102S27.2	40	40
1	25	33.7	25	34.5	19	4	53	71	26.2	52.4	10.5	M10 35	3/8 1 1/2	0.25	PAFSF102S34.5	40	40
1 1/4	32	33.7	25	34.5	21	4	69	80	30.2	58.7	10.5	M10 40	7/16 1 1/2	0.31	PAFSF104S34.5	40	40
1 1/4	32	42.4	31	42.8	21	4	69	80	30.2	58.7	10.5	M10 40	7/16 1 1/2	0.31	PAFSF104S42.8	40	40
1 1/2	38	42.4	31	42.8	24	4	77	95	35.7	69.9	13.5	M12 45	1/2 1 3/4	0.50	PAFSF106S42.8	40	40
1 1/2	38	48.3	38	48.6	24	4	77	95	35.7	69.9	13.5	M12 45	1/2 1 3/4	0.50	PAFSF106S48.6	40	40
2	51	48.3	38	48.6	24	4	89	103	42.9	77.8	13.5	M12 45	1/2 1 3/4	0.59	PAFSF108S48.6	40	40
2	51	60.3	50	61.0	24	4	89	103	42.9	77.8	13.5	M12 45	1/2 1 3/4	0.59	PAFSF108S61.0	40	40
2 1/2	64	60.3	50	61.0	25	5	101	116	50.8	88.9	13.5	M12 45	1/2 1 3/4	0.72	PAFSF110S61.0	40	40
2 1/2	64	76.1	63	76.6	25	5	101	116	50.8	88.9	13.5	M12 45	1/2 1 3/4	0.72	PAFSF110S76.6	40	40
3	76	76.1	63	76.6	25	5	124	136	61.9	106.4	17.0	M16 50	5/8 2	1.25	PAFSF112S76.6	30	30
3	76	88.9	73	90.5	25	5	124	136	61.9	106.4	17.0	M16 50	5/8 2	1.25	PAFSF112S90.5	30	30
3 1/2	89	88.9	73	90.5	25	5	136	152	69.9	120.7	17.0	M16 50	5/8 2	1.50	PAFSF114S90.5	30	30
3 1/2	89	101.6	89	103.0	25	5	136	152	69.9	120.7	17.0	M16 50	5/8 2	1.50	PAFSF114S103	30	30
4	102	101.6	89	103.0	25	6	146	162	77.8	130.2	17.0	M16 50	5/8 2	2.15	PAFSF116S103	30	30
4	102	114.3	99	115.5	25	6	146	162	77.8	130.2	17.0	M16 50	5/8 2	2.15	PAFSF116S115.5	30	30
5	127	114.3	99	115.5	25	6	180	184	92.1	152.4	17.0	M16 50	5/8 2	3.00	PAFSF118S115.5	30	30
5	127	140.0	120	142.5	25	6	180	184	92.1	135.0	17.0	M16 50	5/8 2	3.00	PAFSF118S142.5	30	30

6000 PSI Series

1/2	13	17.2	13	17.5	16	4	46	58	18.2	40.5	9.0	M 8 30	5/16 1 1/4	0.12	PAFSF401S17.5	40	40
1/2	13	21.3	13	21.6	16	4	46	58	18.2	40.5	9.0	M 8 30	5/16 1 1/4	0.12	PAFSF401S21.6	40	40
3/4	19	21.3	13	21.6	19	4	53	71	23.8	50.8	10.5	M10 35	3/8 1 1/2	0.20	PAFSF402S21.6	40	40
3/4	19	26.9	19	27.2	19	4	53	71	23.8	50.8	10.5	M10 35	3/8 1 1/2	0.20	PAFSF402S27.2	40	40
1	25	26.9	19	27.2	24	4	66	80	27.8	57.2	13.5	M12 45	1/2 1 3/4	0.25	PAFSF403S27.2	40	40
1	25	33.7	25	34.5	24	4	66	80	27.8	57.2	13.5	M12 45	1/2 1 3/4	0.25	PAFSF403S34.5	40	40
1 1/4	32	33.7	25	34.5	27	4	77	94	31.8	66.6	15.0	M14 45	1/2 1 3/4	0.31	PAFSF404S34.5	40	40
1 1/4	32	42.4	31	42.8	27	4	77	94	31.8	66.6	15.0	M14 45	1/2 1 3/4	0.31	PAFSF404S42.8	40	40
1 1/2	38	42.4	31	42.8	30	4	89	103	36.5	79.3	17.0	M16 50	5/8 2	0.50	PAFSF405S42.8	40	40
1 1/2	38	48.3	38	48.6	30	4	89	103	36.5	79.3	17.0	M16 50	5/8 2	0.50	PAFSF405S48.6	40	40
2	51	48.3	38	48.6	35	4	123	135	44.5	96.8	21.0	M20 65	3/4 2 1/2	0.59	PAFSF406S48.6	40	40
2	51	60.3	50	61.0	35	4	123	135	44.5	96.8	21.0	M20 65	3/4 2 1/2	0.59	PAFSF406S61.0	40	40

The pressures given here are the maximum allowable for the flange fittings. If the pipe or tube used has a lower pressure rating, then the welded assembly rating will be the lower one, assuming the weld is adequately strong.

*Please add the suffixes below according to the material / surface required.

Order code suffixes					
Material	Suffix surface and material	Example only 4 bolt flange	Example 4 bolt flange incl. metr. screws and O-ring	Example 4 bolt flange incl. UNC screws and O-ring	Standard sealing material (no additional suffix needed)
Steel, blanc oil dipped	S	PAFSF080S17.5S	PAFSF080S17.5SM	PAFSF080S17.5SU	NBR
Stainless steel	SS	PAFSF080S17.5SS	PAFSF080S17.5SSM	PAFSF080S17.5SSU	VIT

¹⁾ Pressure shown = Item deliverable

$$\frac{\text{PN (bar)}}{10} = \text{PN (MPa)}$$

PAFS-90S SAE 90° 4 bolt flange (socket weld)

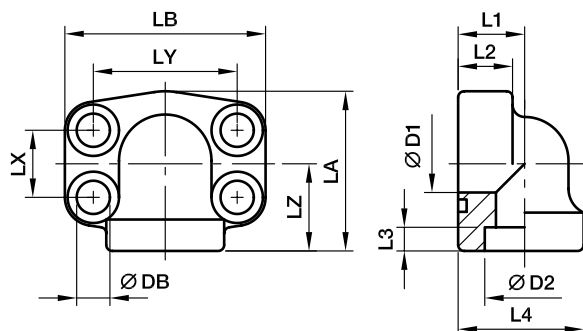
 SAE 90° Flange / Socket weld tube end
 (ISO 6162-1/-2)

3000 PSI Series

Nom. flange size		max.	D1	D2	L1	L2	L3	L4	LA	LB	LX	LY	LZ	DB	Screws			Weight (steel) kg/piece	Order code*	PN (bar) ¹⁾		
SAE (in)	ISO (DN)														(metr.)	(unc.)	1 1/4			S	SS	
1/2	13	21.3	13	21.6	18	17	5	34.0	51	57	17.5	38.1	28	9.0	M 8	30	5/16	1 1/4	0.35	PAFS080/90S21.6	345	345
3/4	19	26.9	19	27.2	22	18	5	38.5	50	68	22.2	47.6	25	10.5	M10	35	3/8	1 1/2	0.55	PAFS100/90S27.2	345	345
1	25	33.7	25	34.1	28	19	6	44.5	55	72	26.2	52.4	28	10.5	M10	35	3/8	1 1/2	0.80	PAFS102/90S34.1	345	345
1 1/4	32	42.4	31	42.8	30	22	7	53.5	68	82	30.2	58.7	34	10.5	M10	40	7/16	1 1/2	1.30	PAFS104/90S42.8	276	276
1 1/2	38	48.3	38	48.6	36	25	8	62.5	82	95	35.7	69.9	43	13.5	M12	45	1/2	1 3/4	1.60	PAFS106/90S48.6	207	207
2	51	60.3	50	61.0	41	25	10	77.0	94	105	42.9	77.8	50	13.5	M12	45	1/2	1 3/4	2.00	PAFS108/90S61	207	207
2 1/2	64	76.1	60	76.6	50	25	28	85.0	127	115	50.8	88.9	77	13.5	M12	45	1/2	1 3/4	2.60	PAFS110/90S76.6	172	172

6000 PSI Series

1/2	13	21.3	13	21.6	18	17	5	34.0	51	57	18.2	40.5	28	9.0	M 8	30	5/16	1 1/4	0.35	PAFS401/90S21.6	420	420
3/4	19	26.9	19	27.2	28	19	6	44.5	55	72	23.8	50.8	28	10.5	M10	35	3/8	1 1/2	0.80	PAFS402/90S27.2	420	420
1	25	33.7	25	34.1	30	24	7	53.5	68	82	27.8	57.2	34	13.5	M12	45	1/2	1 3/4	1.30	PAFS403/90S34.1	420	420
1 1/4	32	42.4	31	42.8	36	25	8	62.5	82	95	31.8	66.6	43	15.0	M14	45	1/2	1 3/4	1.60	PAFS404/90S42.8	420	420
1 1/2	38	48.3	38	48.6	41	26	10	77.0	94	110	36.5	79.3	50	17.0	M16	50	5/8	2	2.00	PAFS405/90S48.6	420	420
2	51	60.3	50	61.0	45	35	12	89.0	123	134	44.5	96.8	65	21.0	M20	65	3/4	2 1/2	2.50	PAFS406/90S61	420	420

¹⁾ Pressure shown = Item deliverable

$$\frac{\text{PN (bar)}}{10} = \text{PN (MPa)}$$

The pressures given here are the maximum allowable for the flange fittings. If the pipe or tube used has a lower pressure rating, then the welded assembly rating will be the lower one, assuming the weld is adequately strong.

*Please add the suffixes below according to the material / surface required.

Order code suffixes					
Material	Suffix surface and material	Example only 4 bolt flange	Example 4 bolt flange incl. metr. screws and O-ring	Example 4 bolt flange incl. UNC screws and O-ring	Standard sealing material (no additional suffix needed)
Steel, blanc oil dipped	S	PAFS080/90S21.6S	PAFS080/90S21.6SM	PAFS080/90S21.6SU	NBR
Stainless steel	SS	PAFS080/90S21.6SS	PAFS080/90S21.6SSM	PAFS080/90S21.6SSU	VIT

PDFS-G SAE Straight 4 bolt flange connection

SAE Flange / Female BSPP thread
(ISO 6162-1/-2) (ISO 1179-1)

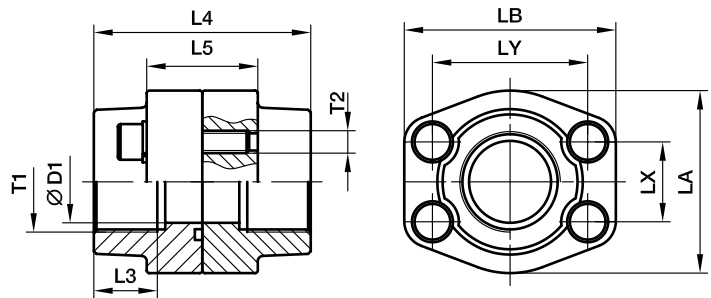

3000 PSI Series

Nom. flange size		T1	D1	L3	L4	L5	LA	LB	LX	LY	T2		Weight (steel) kg/piece	Order code*	PN (bar) ¹⁾	
SAE (in)	ISO (DN)										(metr.)	(unc.)			S	SS
1/2	13	G3/8	13	19	72	32	47	57	17.5	38.1	M 8	5/16	0.50	PDFS080G38	345	345
1/2	13	G1/2	13	19	72	32	47	57	17.5	38.1	M 8	5/16	0.56	PDFS080G	345	345
3/4	19	G3/4	19	19	72	36	49	66	22.3	47.6	M10	3/8	0.78	PDFS100G	345	345
1	25	G1	25	19	76	36	53	71	26.2	52.4	M10	3/8	0.92	PDFS102G	345	345
1 1/4	32	G1 1/4	31	22	82	42	69	80	30.2	58.7	M10	7/16	1.32	PDFS104G	276	276
1 1/2	38	G1 1/2	38	24	88	48	77	94	35.7	69.9	M12	1/2	2.10	PDFS106G	207	207
2	51	G2	50	26	90	48	89	103	42.9	77.8	M12	1/2	2.38	PDFS108G	207	207
2 1/2	64	G2 1/2	63	30	100	48	101	115	50.8	88.9	M12	1/2	2.80	PDFS110G	172	172
3	76	G3	73	34	100	53	124	135	61.9	106.4	M16	5/8	4.30	PDFS112G	138	138
3 1/2	89	G3 1/2	89	27	100	54	136	152	69.9	120.7	M16	5/8	4.80	PDFS114G	34	34
4	102	G4	99	30	100	54	146	162	77.8	130.2	M16	5/8	5.70	PDFS116G	34	34
5	127	G5	120	30	100	54	180	184	92.1	152.4	M16	5/8	6.60	PDFS118G	34	34

6000 PSI Series

1/2	13	G3/8	13	19	72	32	47	57	18.2	40.5	M 8	5/16	0.52	PDFS401G38	420	420
1/2	13	G1/2	13	19	72	32	47	57	18.2	40.5	M 8	5/16	0.58	PDFS401G	420	420
3/4	19	G3/4	19	22	72	38	53	71	23.8	50.8	M10	3/8	1.00	PDFS402G	420	420
1	25	G1	25	24	88	48	69	80	27.8	57.2	M12	7/16	1.52	PDFS403G	420	420
1 1/4	32	G1 1/4	31	25	88	54	77	94	31.8	66.6	M14	1/2	2.40	PDFS404G	420	420
1 1/2	38	G1 1/2	38	28	102	60	89	106	36.5	79.3	M16	5/8	3.30	PDFS405G	420	420
2	51	G2	50	33	140	74	116	135	44.5	96.8	M20	3/4	4.90	PDFS406G	420	420
2 1/2	64	G2 1/2	63	35	150	90	150	166	58.7	123.8	M24	-	6.50	PDFS407G	420	420
3	76	G3	73	40	180	110	178	208	71.4	152.4	M30	-	8.00	PDFS408G	420	420

¹⁾ Pressure shown = Item deliverable

$$\frac{PN \text{ (bar)}}{10} = PN \text{ (MPa)}$$

*Please add the suffixes below according to the material / surface required.

Order code suffixes				
Material	Suffix surface and material	Example 4 bolt flange coupling incl. metr. screws and O-ring	Example 4 bolt flange coupling incl. UNC screws and O-ring	Standard sealing material (no additional suffix needed)
Steel, blanc oil dipped	S	PDFS080GS	PDFS080GSU	NBR
Stainless steel	SS	PDFS080GSS	PDFS080GSSU	VIT



PDFS-B SAE Straight 4 bolt flange connection (butt weld)

SAE Flange / Butt weld tube end
(ISO 6162-1/-2)

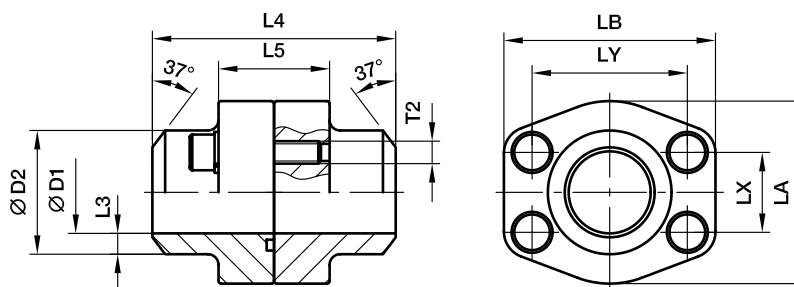

3000 PSI Series

Nom. flange size		max.											T2		Weight (steel) kg/piece	Order code*	PN (bar) ¹⁾	
SAE (in)	ISO (DN)		D1	D2	L3	L4	L5	LA	LB	LX	LY	(metr.)	(unc.)	S			SS	
1/2	13	21.3	13	21.6	4.3	72	32	47	57	17.5	38.1	M 8	5/16	0.50	PDFS080B	345	345	
3/4	19	26.9	19	27.2	4.1	72	36	49	66	22.3	47.6	M10	3/8	0.56	PDFS100B	345	345	
1	25	33.7	25	34.5	4.7	76	36	53	71	26.2	52.4	M10	3/8	0.78	PDFS102B	345	345	
1 1/4	32	42.4	31	42.8	6.0	82	42	69	80	30.2	58.7	M10	7/16	0.92	PDFS104B	345	345	
1 1/2	38	48.3	38	48.6	5.3	88	48	77	94	35.7	69.9	M12	1/2	1.32	PDFS106B	276	276	
2	51	60.3	50	61.0	5.5	90	48	89	103	42.9	77.8	M12	1/2	2.10	PDFS108B	207	207	
2 1/2	64	76.1	63	76.6	6.8	100	48	101	115	50.8	88.9	M12	1/2	2.38	PDFS110B	207	207	
3	76	88.9	73	89.0	8.0	100	53	124	135	61.9	106.4	M16	5/8	2.80	PDFS112B	172	172	
3 1/2	89	101.6	89	103.0	7.0	100	54	137	153	69.9	120.7	M16	5/8	4.30	PDFS114B	138	138	
4	102	114.3	99	115.0	8.0	100	54	147	163	77.8	130.2	M16	5/8	4.80	PDFS116B	34	34	
5	127	140.0	120	141.0	10.5	100	54	180	184	92.1	152.4	M16	5/8	5.70	PDFS118B	34	34	

6000 PSI Series

1/2	13	17.2	10	17.5	3.7	72	32	47	57	18.2	40.5	M 8	5/16	0.52	PDFS401B38	420	420
1/2	13	21.3	13	21.6	4.3	72	32	47	57	18.2	40.5	M 8	5/16	0.58	PDFS401B	420	420
3/4	19	26.9	18	27.2	4.6	72	38	53	71	23.8	50.8	M10	3/8	1.00	PDFS402B	420	420
1	25	33.7	22	34.5	6.3	88	48	66	80	27.8	57.2	M12	7/16	1.52	PDFS403B	420	420
1 1/4	32	42.4	28	42.8	7.4	88	54	77	94	31.8	66.5	M14	1/2	2.40	PDFS404B	420	420
1 1/2	38	48.3	32	48.6	8.3	102	60	89	106	36.5	79.3	M16	5/8	3.30	PDFS405B	420	420
2	51	60.3	41	61.0	10.0	140	74	116	135	44.5	96.8	M20	3/4	4.90	PDFS406B	420	420
2 1/2	64	76.1	50	76.6	13.0	150	90	150	166	58.7	123.8	M24	-	6.50	PDFS407B	420	420
3	76	88.9	58	90.0	16.0	180	110	178	208	71.4	152.4	M30	-	8.00	PDFS408B	420	420

1) Pressure shown = Item deliverable

$$\frac{\text{PN (bar)}}{10} = \text{PN (MPa)}$$

The pressures given here are the maximum allowable for the flange fittings. If the pipe or tube used has a lower pressure rating, then the welded assembly rating will be the lower one, assuming the weld is adequately strong.

*Please add the suffixes below according to the material / surface required.

Order code suffixes				
Material	Suffix surface and material	Example 4 bolt flange coupling incl. metr. screws and O-ring	Example 4 bolt flange coupling incl. UNC screws and O-ring	Standard sealing material (no additional suffix needed)
Steel, blanc oil dipped	S	PDFS080BS	PDFS080BSU	NBR
Stainless steel	SS	PDFS080BSS	PDFS080BSSU	VIT

PDFS-S SAE Straight 4 bolt flange connection (socket weld)

SAE Flange / Socket weld tube end
(ISO 6162-1/-2)

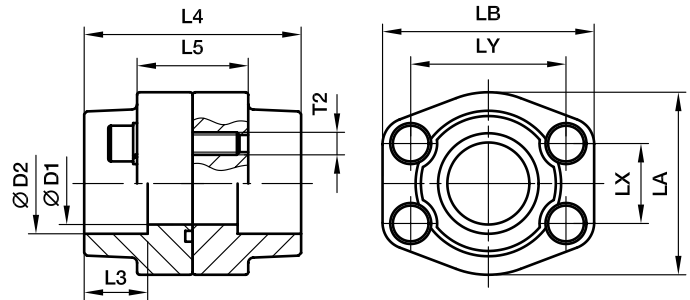

3000 PSI Series

Nom. flange size		max.	D1	D2	L3	L4	L5	LA	LB	LX	LY	T2		Weight (steel) kg/piece	Order code*	PN (bar) ¹⁾	
SAE (in)	ISO (DN)											(metr.)	(unc.)			S	SS
1/2	13	17.2	13	17.5	18	72	36	47	57	17.5	38.1	M 8	5/16	0.50	PDFS080S17.5	345	345
1/2	13	21.3	13	21.6	18	72	36	47	57	17.5	38.1	M 8	5/16	0.50	PDFS080S21.6	345	345
3/4	19	26.9	19	27.2	18	72	36	49	66	22.3	47.6	M10	3/8	0.56	PDFS100S27.2	345	345
1	25	33.7	25	34.1	18	76	36	53	71	26.2	52.4	M10	3/8	0.78	PDFS102S34.1	345	345
1 1/4	32	42.4	31	42.8	20	82	42	69	80	30.2	58.7	M10	7/16	0.92	PDFS104S42.8	345	345
1 1/2	38	48.3	38	48.6	22	88	48	77	94	35.7	69.9	M12	1/2	1.32	PDFS106S48.6	276	276
2	51	60.3	50	61.0	24	90	48	89	103	42.9	77.8	M12	1/2	2.10	PDFS108S61	207	207
2 1/2	64	76.1	63	76.6	28	100	48	101	116	50.8	88.9	M12	1/2	2.38	PDFS110S76.6	207	207
3	76	88.9	73	90.5	28	100	53	124	135	61.9	106.4	M16	5/8	2.80	PDFS112S90.5	172	172
3 1/2	89	101.6	89	103.0	28	100	54	137	153	69.9	120.7	M16	5/8	4.30	PDFS114S103	138	138
4	102	114.3	99	115.5	28	100	54	147	163	77.8	130.2	M16	5/8	4.80	PDFS116S115.5	34	34
5	127	140.0	120	142.0	28	100	54	180	184	92.1	152.4	M16	5/8	5.70	PDFS118S142	34	34

6000 PSI Series

1/2	13	17.2	13	17.5	18	72	32	47	57	18.2	40.5	M 8	5/16	0.52	PDFS401S17.5	420	420
1/2	13	21.3	13	21.6	18	72	32	47	57	18.2	40.5	M 8	5/16	0.58	PDFS401S21.6	420	420
3/4	19	26.9	19	27.2	20	72	38	53	71	23.8	50.8	M10	3/8	1.00	PDFS402S27.2	420	420
1	25	33.7	25	34.1	22	88	48	66	80	27.8	57.2	M12	7/16	1.52	PDFS403S34.1	420	420
1 1/4	32	42.4	31	42.8	22	88	54	77	94	31.8	66.6	M14	1/2	2.40	PDFS404S42.8	420	420
1 1/2	38	48.3	38	48.6	24	102	60	89	106	36.5	79.3	M16	5/8	3.30	PDFS405S48.6	420	420
2	51	60.3	50	61.0	25	140	74	116	135	44.5	96.8	M20	3/4	4.90	PDFS406S61	420	420
2 1/2	64	76.1	63	76.6	28	150	90	150	166	58.7	123.8	M24	-	6.50	PDFS407S76.6	420	420
3	76	88.9	73	90.5	30	180	110	178	208	71.4	152.4	M30	-	8.00	PDFS408S90.5	420	420

¹⁾ Pressure shown = Item deliverable

$$\frac{PN \text{ (bar)}}{10} = PN \text{ (MPa)}$$

The pressures given here are the maximum allowable for the flange fittings. If the pipe or tube used has a lower pressure rating, then the welded assembly rating will be the lower one, assuming the weld is adequately strong.

*Please add the suffixes below according to the material / surface required.

Order code suffixes				
Material	Suffix surface and material	Example 4 bolt flange coupling incl. metr. screws and O-ring	Example 4 bolt flange coupling incl. UNC screws and O-ring	Standard sealing material (no additional suffix needed)
Steel, blanc oil dipped	S	PDFS080S17.5S	PDFS080S17.5SU	NBR
Stainless steel	SS	PDFS080S17.5SS	PDFS080S17.5SSU	VIT

PCFF SAE Closed flange

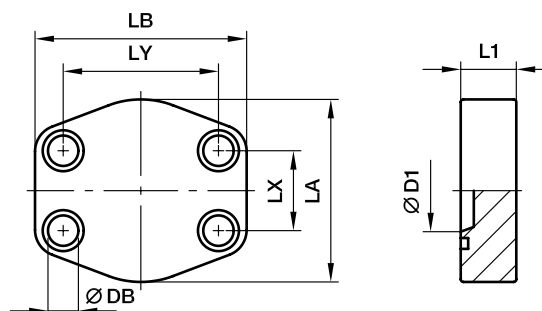
 SAE Closed flange
(ISO 6162-1/-2)

3000 PSI Series

Nom. flange size		D1	L1	LA	LB	LX	LY	DB	Screws		Weight (steel) kg/piece	Order code*	PN (bar) ¹⁾	
SAE (in)	ISO (DN)								(metr.)	(unc.)			S	SS
1/2	13	13	16	46	58	17.5	38.1	9.0	M 8 30	5/16 1 1/4	0.30	PCFF32	345	345
3/4	19	15	18	49	66	22.3	47.6	10.5	M10 35	3/8 1 1/2	0.37	PCFF33	345	345
1	25	18	19	53	71	26.2	52.4	10.5	M10 35	3/8 1 1/2	0.54	PCFF34	345	345
1 1/4	32	23	21	69	80	30.2	58.7	10.5	M10 40	7/16 1 1/2	0.90	PCFF35	276	276
1 1/2	38	28	24	77	95	35.7	69.9	13.5	M12 45	1/2 1 3/4	1.03	PCFF36	207	207
2	51	45	24	89	103	42.9	77.8	13.5	M12 45	1/2 1 3/4	1.30	PCFF38	207	207
2 1/2	64	58	25	101	116	50.8	88.9	13.5	M12 45	1/2 1 3/4	1.45	PCFF310	172	172
3	76	70	25	124	136	61.9	106.4	17.0	M16 50	5/8 2	2.72	PCFF312	138	138
3 1/2	89	85	25	136	152	69.9	120.7	17.0	M16 50	5/8 2	2.90	PCFF314	34	34
4	102	95	25	146	162	77.8	130.2	17.0	M16 50	5/8 2	3.85	PCFF316	34	34
5	127	110	25	180	184	92.1	152.4	17.0	M16 50	5/8 2	4.20	PCFF320	34	34

6000 PSI Series

1/2	13	13	16	46	58	18.2	40.5	9.0	M 8 30	5/16 1 1/4	0.30	PCFF62	420	420
3/4	19	15	19	53	71	23.8	50.8	10.5	M10 35	3/8 1 1/2	0.44	PCFF63	420	420
1	25	22	24	66	80	27.8	57.2	13.5	M12 45	1/2 1 3/4	0.73	PCFF64	420	420
1 1/4	32	30	27	77	94	31.8	66.6	15.0	M14 45	1/2 1 3/4	0.85	PCFF65	420	420
1 1/2	38	35	30	89	103	36.5	79.3	17.0	M16 50	5/8 2	1.61	PCFF66	420	420
2	51	48	35	123	135	44.5	96.8	21.0	M20 65	3/4 2 1/2	3.31	PCFF68	420	420
2 1/2	64	55	45	150	166	58.7	123.8	25.0	M24 85	-	4.50	PCFF610	420	420
3	76	65	55	178	208	71.4	152.4	32.0	M30 110	-	5.30	PCFF612	420	420

1) Pressure shown = Item deliverable

$$\frac{\text{PN (bar)}}{10} = \text{PN (MPa)}$$

*Please add the suffixes below according to the material / surface required.

Order code suffixes					
Material	Suffix surface and material	Example only closed flange	Example closed flange incl. metr. screws and O-ring	Example closed flange incl. UNC screws and O-ring	Standard sealing material (no additional suffix needed)
Steel, blanc oil dipped	S	PCFF32S	PCFF32SM	PCFF32SU	NBR
Stainless steel	SS	PCFF32SS	PCFF32SSM	PCFF32SSU	VIT

PCCFF SAE Closed counter flange

SAE Closed counter flange
(ISO 6162-1/-2)

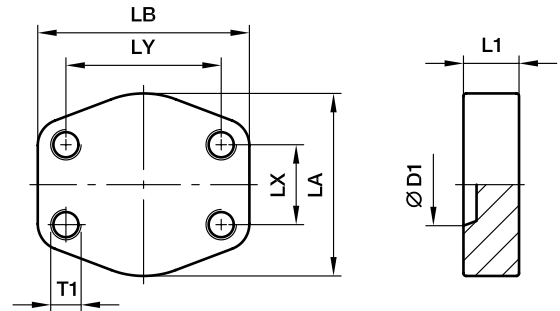

3000 PSI Series

Nom. flange size		D1	L1	LA	LB	LX	LY	T1		Weight (steel) kg/piece	Order code*	PN (bar) ¹⁾	
SAE (in)	ISO (DN)							(metr.)	(unc.)			S	SS
1/2	13	13	16	46	58	17.5	38.1	M 8	5/16	0.30	PCCFF32	345	345
3/4	19	15	18	49	66	22.3	47.6	M10	3/8	0.37	PCCFF33	345	345
1	25	18	19	53	71	26.2	52.4	M10	3/8	0.54	PCCFF34	345	345
1 1/4	32	23	21	69	80	30.2	58.7	M10	7/16	0.90	PCCFF35	276	276
1 1/2	38	28	24	77	95	35.7	69.9	M12	1/2	1.03	PCCFF36	207	207
2	51	45	24	89	103	42.9	77.8	M12	1/2	1.20	PCCFF38	207	207
2 1/2	64	58	25	101	116	50.8	88.9	M12	1/2	1.45	PCCFF310	172	172
3	76	70	25	124	136	61.9	106.4	M16	5/8	2.72	PCCFF312	138	138
3 1/2	89	85	25	136	152	69.9	120.7	M16	5/8	2.90	PCCFF314	34	34
4	102	95	25	146	162	77.8	130.2	M16	5/8	3.85	PCCFF316	34	34
5	127	110	25	180	184	92.1	152.4	M16	5/8	4.20	PCCFF320	34	34

6000 PSI Series

1/2	13	13	16	46	58	18.2	40.5	M 8	5/16	0.30	PCCFF62	420	420
3/4	19	15	19	53	71	23.8	50.8	M10	3/8	0.44	PCCFF63	420	420
1	25	22	24	66	80	27.8	57.2	M12	7/16	0.73	PCCFF64	420	420
1 1/4	32	30	27	77	94	31.8	66.6	M14	1/2	0.85	PCCFF65	420	420
1 1/2	38	35	30	89	103	36.5	79.3	M16	5/8	1.61	PCCFF66	420	420
2	51	48	35	123	135	44.5	96.8	M20	3/4	3.31	PCCFF68	420	420
2 1/2	64	55	45	150	166	58.7	123.8	M24	–	4.50	PCCFF610	420	420
3	76	65	55	178	208	71.4	152.4	M30	–	5.30	PCCFF612	420	420

1) Pressure shown = Item deliverable

$$\frac{PN \text{ (bar)}}{10} = PN \text{ (MPa)}$$

*Please add the suffixes below according to the material / surface required.

Order code suffixes				
Material	Suffix surface and material	Example closed flange with metr. threads	Example closed flange with UNC threads	Standard sealing material (no additional suffix needed)
Steel, blanc oil dipped	S	PCCFF32SM	PCCFF32SU	NBR
Stainless steel	SS	PCCFF32SSM	PCCFF32SSU	VIT



CPM SAE Flange connector plate

ISO 6162-1/-2

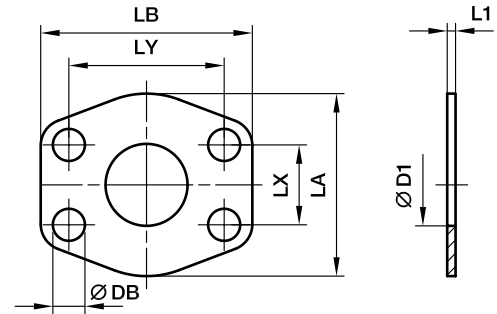

3000 PSI Series

Nom. flange size		D1	L1	LA	LB	LX	LY	DB	Weight (steel) kg/piece	Order code*	PN (bar) ¹⁾	
SAE (in)	ISO (DN)										S	SS
1/2	13	13	3	47	57	17.5	38.1	9.0	0.01	8CPM1	345	345
3/4	19	19	3	49	66	22.3	47.6	11.0	0.01	12CPM1	345	345
1	25	25	3	53	71	26.2	52.4	11.0	0.01	16CPM1	345	345
1 1/4	32	32	3	69	80	30.2	58.7	11.5	0.02	20CPM1	276	276
1 1/2	38	38	3	77	95	35.7	69.9	13.5	0.02	24CPM1	207	207
2	51	51	3	89	103	42.9	77.8	13.5	0.03	32CPM1	207	207
2 1/2	64	63	3	101	116	50.8	88.9	13.5	0.03	40CPM1	172	172
3	76	73	4	124	136	61.9	106.4	17.0	0.04	48CPM1	138	138
3 1/2	89	89	4	136	152	69.9	120.7	17.0	0.06	56CPM1	34	34
4	102	99	4	146	162	77.8	130.2	17.0	0.08	64CPM1	34	34
5	127	120	4	180	184	92.1	152.4	17.0	0.09	80CPM1	34	34

6000 PSI Series

1/2	13	13	4	47	57	18.2	40.5	9.0	0.01	8CPM2	420	420
3/4	19	17	4	53	71	23.8	50.8	11.0	0.01	12CPM2	420	420
1	25	24	4	66	80	27.8	57.2	13.0	0.02	16CPM2	420	420
1 1/4	32	31	4	77	94	31.8	66.6	15.0	0.03	20CPM2	420	420
1 1/2	38	38	4	89	103	36.5	79.3	17.0	0.04	24CPM2	420	420
2	51	51	4	123	135	44.5	96.8	21.0	0.05	32CPM2	420	420
2 1/2	64	63	4	150	166	58.7	123.8	25.0	0.07	40CPM2	420	420
3	76	73	4	178	208	71.4	152.4	32.0	0.08	48CPM2	420	420

¹⁾ Pressure shown = Item deliverable

$$\frac{\text{PN (bar)}}{10} = \text{PN (MPa)}$$

*Please add the suffixes below according to the material / surface required.

Order code suffixes			
Material	Suffix surface and material	Example	Description
Steel, zinc plated, chrome ⁶ -free	CF	8CPM1CF	only connector plate
Steel, zinc yellow plated	A3C	8CPM1A3C	only connector plate
Stainless steel	SS	8CPM1SS	only connector plate

AP SAE Flange locking plate

ISO 6162-1/-2

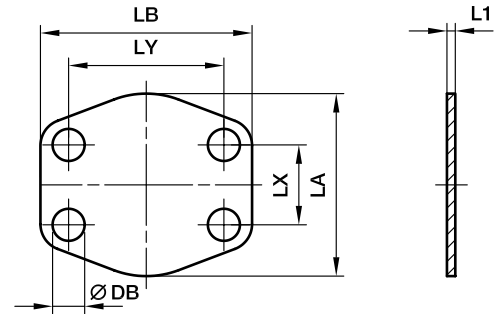

3000 PSI Series

Nom. flange size		L1	LA	LB	LX	LY	DB	Weight (steel) kg/piece	Order code*	PN (bar) ¹⁾	
SAE (in)	ISO (DN)									S	SS
1/2	13	3	47	57	17.5	38.1	9.0	0.02	8AP1	-	-
3/4	19	3	49	66	22.3	47.6	11.0	0.02	12AP1	-	-
1	25	3	53	71	26.2	52.4	11.0	0.02	16AP1	-	-
1 1/4	32	3	69	80	30.2	58.7	11.5	0.03	20AP1	-	-
1 1/2	38	3	77	95	35.7	69.9	13.5	0.03	24AP1	-	-
2	51	3	89	103	42.9	77.8	13.5	0.04	32AP1	-	-
2 1/2	64	3	101	116	50.8	89.9	13.5	0.04	40AP1	-	-
3	76	4	124	136	61.9	106.4	17.0	0.07	48AP1	-	-
3 1/2	89	4	136	152	69.9	102.7	17.0	0.07	56AP1	-	-
4	102	4	146	162	77.8	130.2	17.0	0.09	64AP1	-	-
5	127	4	180	184	92.1	152.4	17.0	0.10	80AP1	-	-

6000 PSI Series

1/2	13	4	47	57	18.2	40.5	9.0	0.02	8AP2	-	-
3/4	19	4	53	71	23.8	50.8	11.0	0.02	12AP2	-	-
1	25	4	66	80	27.8	57.1	13.0	0.03	16AP2	-	-
1 1/4	32	4	77	94	31.8	66.7	15.0	0.04	20AP2	-	-
1 1/2	38	4	89	103	36.5	79.4	17.0	0.05	24AP2	-	-
2	51	4	123	135	44.5	96.8	21.0	0.06	32AP2	-	-
2 1/2	64	4	150	166	58.7	123.8	25.0	0.08	40AP2	-	-
3	76	4	178	208	71.4	152.4	32.0	0.10	48AP2	-	-

1) Pressure shown = Item deliverable

$$\frac{\text{PN (bar)}}{10} = \text{PN (MPa)}$$

This flange locking plate is not used under pressure.

*Please add the suffixes below according to the material / surface required.

Order code suffixes			
Material	Suffix surface and material	Example	Description
Steel, zinc plated, chrome ⁶ -free	CF	8AP1CF	only locking plate
Steel, zinc yellow plated	A3C	8AP1A3C	only locking plate
Stainless steel	SS	8AP1SS	only locking plate

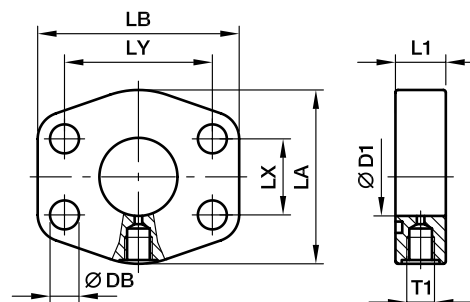

PAGL-(G/M) SAE 4 bolt flange with test point port

 SAE Flange with test point port
(ISO 6162-1/-2)

3000 PSI Series

Nom. flange size		T1	D1	L1	LA	LB	LX	LY	DB	Weight (steel) kg/piece	Order code*	PN (bar) ¹⁾	
SAE (in)	ISO (DN)											S	SS
1	25	G1/4	25	19	53	71	26.2	52.4	11.0	0.65	PAGL102G14	348	348
1	25	M10 1	25	19	53	71	26.2	52.4	11.0	0.65	PAGL102M10	348	348
1 1/4	32	G1/4	31	20	69	80	30.2	58.7	11.5	0.75	PAGL104G14	278	278
1 1/4	32	M10 1	31	20	69	80	30.2	58.7	11.5	0.75	PAGL104M10	278	278
1 1/2	38	G1/4	38	25	77	94	35.7	69.9	13.5	0.80	PAGL106G14	210	210
1 1/2	38	M10 1	38	25	77	94	35.7	69.9	13.5	0.80	PAGL106M10	210	210
2	51	G1/4	50	25	89	103	42.9	77.8	13.5	1.25	PAGL108G14	210	210
2	51	M10 1	50	25	89	103	42.9	77.8	13.5	1.25	PAGL108M10	210	210
2 1/2	64	G1/4	63	25	101	115	50.8	88.9	13.5	1.75	PAGL110G14	175	175
2 1/2	64	M10 1	63	25	101	115	50.8	88.9	13.5	1.75	PAGL110M10	175	175
3	76	G1/4	73	27	124	135	61.9	106.4	17.0	2.25	PAGL112G14	138	138
3	76	M10 1	73	27	124	135	61.9	106.4	17.0	2.25	PAGL112M10	138	138
3 1/2	89	G1/4	89	27	136	152	61.9	120.7	17.0	3.00	PAGL114G14	35	35
3 1/2	89	M10 1	89	27	136	152	61.9	120.7	17.0	3.00	PAGL114M10	35	35
4	102	G1/4	99	26	146	162	77.8	130.2	17.0	4.25	PAGL116G14	35	35
4	102	M10 1	99	26	146	162	77.8	130.2	17.0	4.25	PAGL116M10	35	35
5	127	G1/4	120	23	180	184	92.1	152.4	17.0	5.75	PAGL118G14	35	35
5	127	M10 1	120	23	180	184	92.1	152.4	17.0	5.75	PAGL118M10	35	35

6000 PSI Series

1	25	G1/4	25	22	69	80	27.8	57.2	13.0	0.65	PAGL403G14	420	420
1	25	M10 1	25	22	69	80	27.8	57.2	13.0	0.65	PAGL403M10	420	420
1 1/4	32	G1/4	31	26	77	94	31.8	66.6	15.0	0.75	PAGL404G14	420	420
1 1/4	32	M10 1	31	26	77	94	31.8	66.6	15.0	0.75	PAGL404M10	420	420
1 1/2	38	G1/4	38	30	89	106	36.5	79.3	17.0	0.95	PAGL405G14	420	420
1 1/2	38	M10 1	38	30	89	106	36.5	79.3	17.0	0.85	PAGL405M10	420	420
2	51	G1/4	50	36	116	135	44.5	96.8	21.0	1.25	PAGL406G14	420	420
2	51	M10 1	50	36	116	135	44.5	96.8	21.0	1.25	PAGL406M10	420	420
2 1/2	64	G1/4	63	45	150	166	58.7	123.8	25.0	1.75	PAGL408G14	420	420
2 1/2	64	M10 1	63	45	150	166	58.7	123.8	25.0	1.75	PAGL408M10	420	420
3	76	G1/4	73	55	178	208	71.4	152.4	32.0	2.25	PAGL410G14	420	420
3	76	M10 1	73	55	178	208	71.4	152.4	32.0	2.25	PAGL410M10	420	420

1) Pressure shown = Item deliverable

$$\frac{\text{PN (bar)}}{10} = \text{PN (MPa)}$$

*Please add the suffixes below according to the material / surface required.

Order code suffixes			
Material	Suffix surface and material	Example	Description
Steel, blanc oil dipped	S	PAGL102G14S	only flange
Stainless steel	SS	PAGL102G14SS	only flange

PRF SAE Straight reducing flange adapter

ISO 6162-1/-2

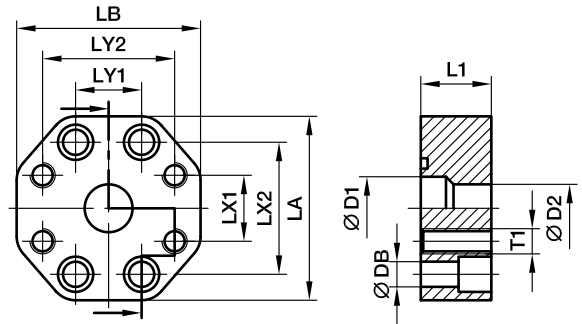

3000 PSI Series

Nom. flange size		D1	D2	L1	LA	LB	LX1	LX2	LY1	LY2	DB	Screws		Weight (steel) kg/piece	Order code*	PN (bar) ¹⁾
SAE (in)	ISO (DN)											(metr.)	T1			
1 1	25/25	25	25	28	73	73	26.2	52.4	26.2	52.4	11	M10 35	M10	1.10	PRF102/102	210
1 3/4	25/19	25	19	28	73	73	22.3	52.4	26.2	47.6	11	M10 35	M10	1.15	PRF102/100	210
1 1/4 1 1/4	32/32	30	30	28	80	80	30.2	58.7	30.2	58.7	11	M10 35	M10	1.55	PRF104/104	210
1 1/4 1	32/25	30	25	28	80	71	26.2	58.7	30.2	52.4	11	M10 35	M10	1.55	PRF104/102	210
1 1/2 1 1/2	38/38	38	38	32	94	94	35.7	69.9	35.7	69.9	13	M12 45	M12	2.25	PRF106/106	210
1 1/2 1 1/4	38/32	38	30	32	94	80	30.2	69.9	35.7	58.7	13	M10 35	M10	2.40	PRF106/104	210
2 2	51/51	50	50	33	103	103	42.9	77.8	42.9	77.8	13	M12 45	M12	3.00	PRF108/108	210
2 1 1/2	51/38	50	38	33	103	94	35.7	77.8	42.9	70.0	13	M12 45	M12	3.15	PRF108/106	210
2 1/2 2 1/2	64/64	63	63	33	115	115	50.8	88.9	50.8	88.9	13	M12 45	M12	3.85	PRF110/110	175
2 1/2 2	64/51	63	50	33	115	103	42.9	88.9	50.8	77.8	13	M12 45	M12	3.95	PRF110/108	175
3 3	76/76	73	73	36	135	135	61.9	106.4	61.9	106.4	17	M16 50	M16	4.25	PRF112/112	138
3 2 1/2	76/64	73	63	36	135	115	50.8	106.4	61.9	89.0	17	M12 45	M12	4.45	PRF112/110	138

6000 PSI Series

3/4 3/4	19/19	19	19	28	71	71	23.8	50.8	23.8	50.8	11	M10 35	M10	0.80	PRF402/402	420
1 1	25/25	25	25	33	80	80	27.8	57.2	27.8	57.2	13	M12 45	M12	1.10	PRF403/403	420
1 3/4	25/19	25	19	33	80	71	23.8	57.2	27.8	50.8	13	M10 35	M10	1.10	PRF403/402	420
1 1/4 1 1/4	32/32	30	30	33	94	94	31.8	66.6	31.8	66.6	15	M14 45	M14	1.40	PRF404/404	420
1 1/4 1	32/25	30	25	33	94	80	27.8	66.6	31.8	57.2	15	M12 45	M12	1.60	PRF404/403	420
1 1/2 1 1/2	38/38	38	38	48	106	106	36.5	79.3	36.5	79.3	17	M16 50	M16	3.30	PRF405/405	420
1 1/2 1 1/4	38/32	38	30	48	106	94	31.8	79.3	36.5	66.6	17	M14 45	M14	3.60	PRF405/404	420
2 2	51/51	50	50	48	135	135	44.5	96.8	44.5	96.8	21	M20 65	M20	5.00	PRF406/406	420
2 1 1/2	51/38	50	38	48	135	106	36.5	96.8	44.5	79.3	21	M16 50	M16	5.25	PRF406/405	420
2 1/2 2	64/51	63	50	53	166	150	44.5	123.8	58.7	96.8	25	M20 65	M20	6.50	PRF408/406	420
3 2	76/51	73	50	58	208	178	44.5	152.4	71.4	96.8	31	M20 65	M20	7.50	PRF410/406	420

¹⁾ Pressure shown = Item deliverable

$$\frac{\text{PN (bar)}}{10} = \text{PN (MPa)}$$

*Please add the suffixes below according to the material / surface required.

Order code suffixes			
Material	Suffix surface and material	Example	Description
Steel, blanc oil dipped	S	PRF102/102S	only flange
Stainless steel	SS	PRF102/102SS	only flange



PBL SAE 90° L-block

SAE Flange 90° block
(ISO 6162-1/-2)

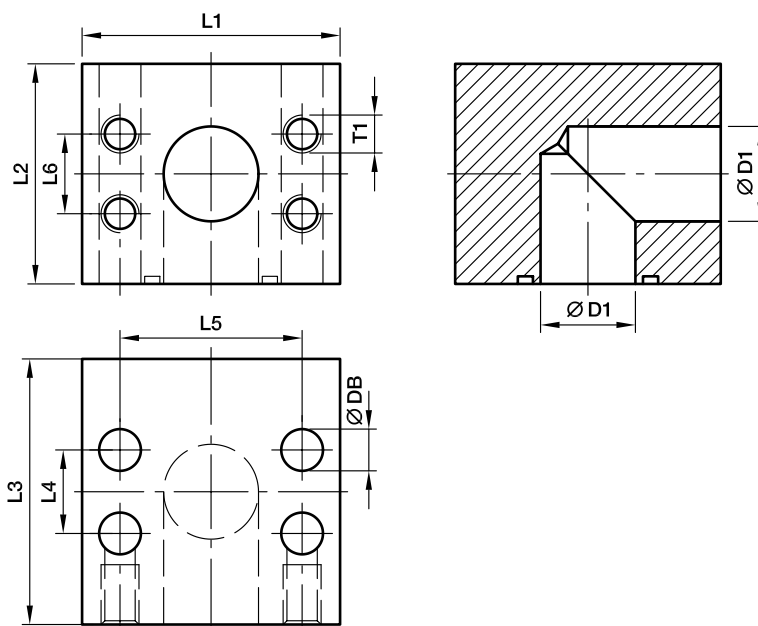

3000 PSI Series

Nom. flange size		D1	L1	L2	L3	L4	L5	L6	DB	T1	Weight (steel) kg/piece	Order code*	PN (bar) ¹⁾	
SAE (in)	ISO (DN)												S	SS
1 1/4	32	31	80	80	80	30.2	58.7	30.2	11.0	M10	3.50	PBL304	210	210
1 1/2	38	38	94	94	94	35.7	69.9	35.7	13.5	M12	5.00	PBL305	210	210
2	51	50	103	87	97	42.9	77.8	42.9	13.5	M12	7.90	PBL306	210	210

6000 PSI Series

3/4	19	19	70	55	60	23.8	50.8	23.8	11.0	M10	1.40	PBL602	420	420
1	25	25	80	69	69	27.8	57.2	27.8	13.0	M12	2.30	PBL603	420	420
1 1/4	32	30	94	75	75	31.8	66.6	31.8	15.0	M14	3.30	PBL604	420	420
1 1/2	38	38	106	89	89	36.5	79.3	36.5	17.0	M16	5.30	PBL605	420	420
2	51	50	135	116	116	44.5	96.8	44.5	21.0	M20	9.40	PBL606	420	420

¹⁾ Pressure shown = Item deliverable

$$\frac{\text{PN (bar)}}{10} = \text{PN (MPa)}$$

*Please add the suffixes below according to the material / surface required.

Order code suffixes			
Material	Suffix surface and material	Example	Description
Steel, blanc oil dipped	S	PBL304S	only flange block
Stainless steel	SS	PBL304SS	only flange block

PBLR SAE 90° L-reduction block

SAE Flange reduction 90° block
(ISO 6162-1/-2)

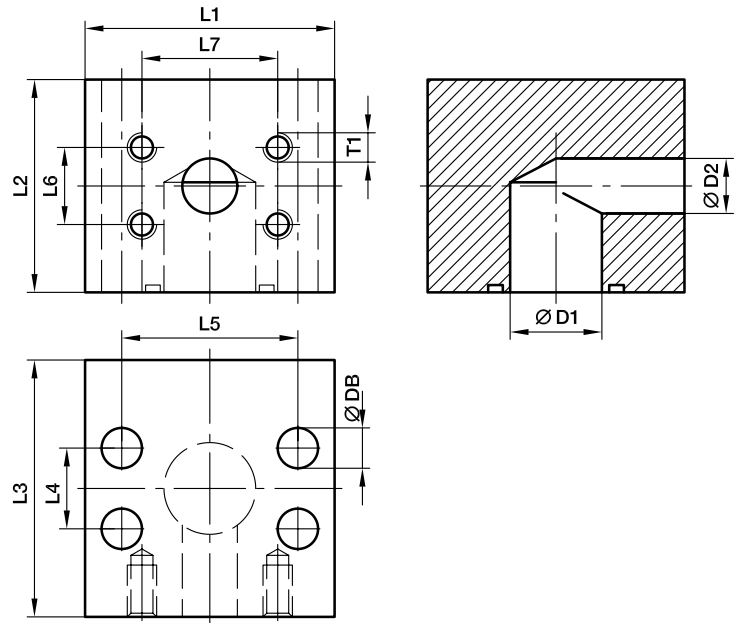

6000 PSI Series

Nom. flange size		D1	D2	L1	L2	L3	L4	L5	L6	L7	DB	T1	Weight (steel) kg/piece	Order code*	PN (bar) ¹⁾	
SAE (in)	ISO (DN)														S	SS
1	25	25	19	80	69	69	27.8	57.2	23.8	50.8	13	M10	2.30	PBLR403-402	420	420
1 1/4	32	30	19	94	75	75	31.8	66.6	23.8	50.8	15	M10	3.30	PBLR404-402	420	420
1 1/4	32	30	25	94	75	75	31.8	66.6	27.8	57.2	15	M12	2.90	PBLR404-403	420	420
1 1/2	38	38	30	106	89	89	36.5	79.3	31.6	66.6	17	M14	5.40	PBLR405-404	420	420
2	51	50	38	135	116	116	44.5	96.8	36.7	79.3	21	M16	9.00	PBLR406-405	420	420

¹⁾ Pressure shown = Item deliverable

$$\frac{PN \text{ (bar)}}{10} = PN \text{ (MPa)}$$



*Please add the suffixes below according to the material / surface required.

Order code suffixes			
Material	Suffix surface and material	Example	Description
Steel, blanc oil dipped	S	PBLR403-402S	only flange block
Stainless steel	SS	PBLR403-402SS	only flange block

PBT SAE 90° T-block

SAE Flange T-block
(ISO 6162-1/-2)

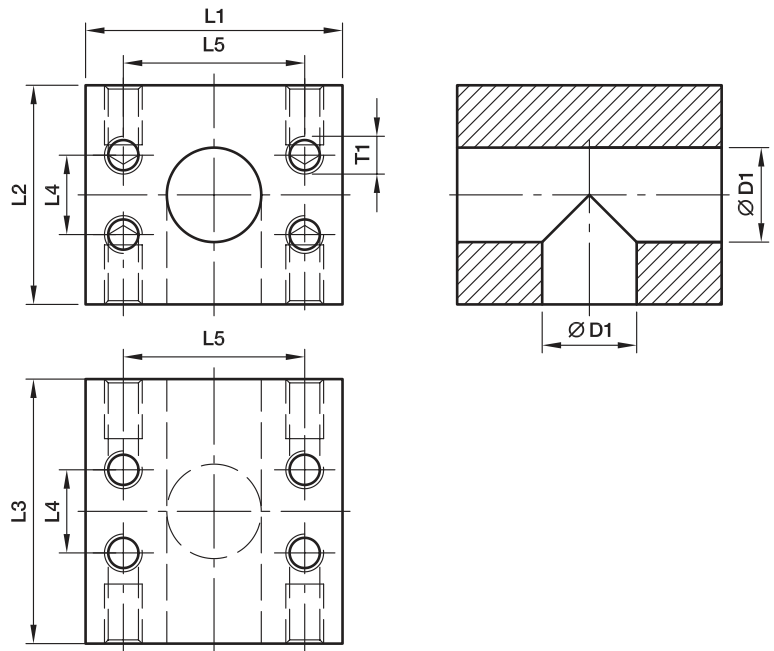

6000 PSI Series

Nom. flange size		D1	L1	L2	L3	L4	L5	L6	DB	T1	Weight (steel) kg/piece	Order code*	PN (bar) ¹⁾	
SAE (in)	ISO (DN)												S	SS
3/4	19	19	70	55	70	23.8	50.8	23.8	11	M10	1.70	PBT602-602	420	420
1	25	20	80	69	80	27.8	57.2	27.8	13	M12	2.90	PBT603-603	420	420
1 1/4	32	30	94	75	94	31.8	66.6	31.6	15	M14	3.80	PBT604-604	420	420
1 1/2	38	38	106	100	106	36.5	79.3	36.7	17	M16	8.90	PBT605-605	420	420
2	51	50	135	116	140	44.5	96.8	44.4	21	M20	12.70	PBT606-606	420	420

¹⁾ Pressure shown = Item deliverable

$$\frac{PN \text{ (bar)}}{10} = PN \text{ (MPa)}$$

*Please add the suffixes below according to the material / surface required.

Order code suffixes			
Material	Suffix surface and material	Example	Description
Steel, blanc oil dipped	S	PBT602-602S	only flange block
Stainless steel	SS	PBT602-602SS	only flange block

PBTC SAE Counter flange T-block

ISO 6162-1/-2

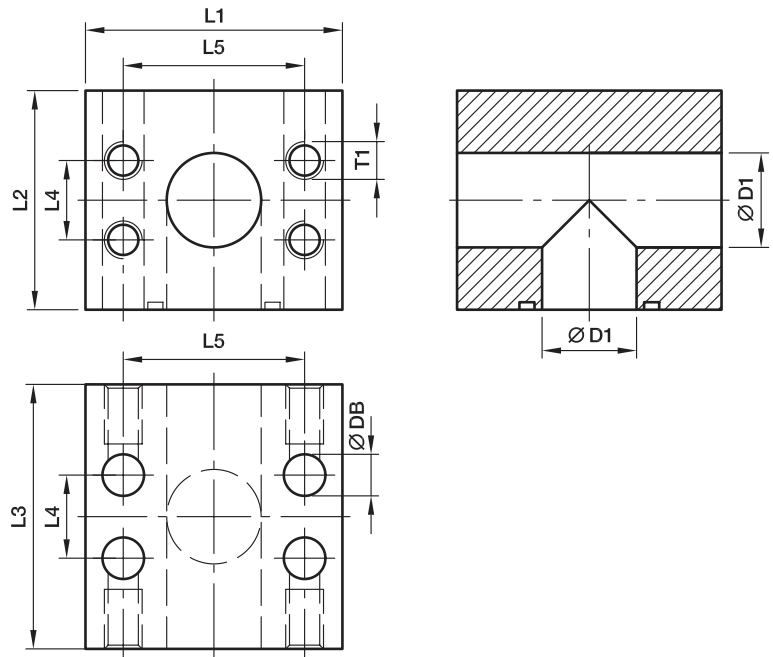

6000 PSI Series

Nom. flange size		D1	L1	L2	L3	L4	L5	L6	T1	Weight (steel) kg/piece	Order code*	PN (bar) ¹⁾	
SAE (in)	ISO (DN)											S	SS
3/4	19	19	70	55	70	23.8	50.8	23.8	M10	1.70	PBTC602-602	420	420
1	25	25	80	69	80	27.8	57.2	27.8	M12	2.90	PBTC603-603	420	420
1 1/4	32	30	94	75	94	31.8	66.6	31.6	M14	3.80	PBTC604-604	420	420
1 1/2	38	38	106	100	106	36.5	79.3	36.7	M16	8.90	PBTC605-605	420	420
2	51	50	135	116	140	44.5	96.8	44.4	M20	12.70	PBTC606-606	420	420

¹⁾ Pressure shown = Item deliverable

$$\frac{PN \text{ (bar)}}{10} = PN \text{ (MPa)}$$



*Please add the suffixes below according to the material / surface required.

Order code suffixes			
Material	Suffix surface and material	Example	Description
Steel, blanc oil dipped	S	PBTC602-602S	only flange block
Stainless steel	SS	PBTC602-602SS	only flange block

BFG Gear pump flange straight

Hydraulic flange / EO 24° cone end

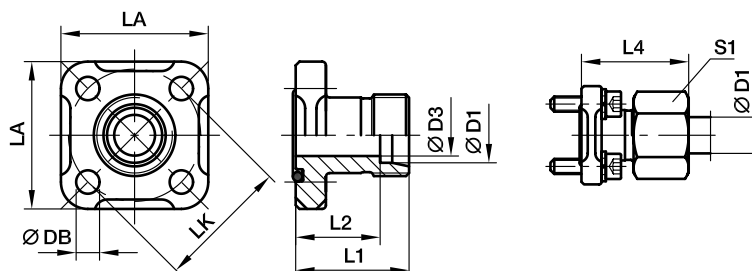

BFG Straight flange connection EO 24° cone end

LK	D1 ²⁾	D3	L1	L2	L4	LA	S1	DB	Screws (metr.)	O-ring	Weight (steel) kg/piece	Order code*	PN (bar) ¹⁾ A3C
35	10L	8	30	23.0	39.0	39	19	6.4	M6 22	20 2.5	0.15	BFG10L/LK35	200
35	12L	10	30	23.0	39.0	39	22	6.4	M6 22	20 2.5	0.16	BFG12L/LK35	200
35	15L	12	30	23.0	38.0	39	27	6.4	M6 22	20 2.5	0.19	BFG15L/LK35	160
35	16S	12	30	21.5	39.5	39	30	6.4	M6 22	20 2.5	0.21	BFG16S/LK35	315
40	15L	12	35	28.0	43.0	42	27	6.4	M6 22	26 2.5	0.17	BFG15L/LK40	64
40	18L	15	35	27.5	44.0	42	32	6.4	M6 22	26 2.5	0.22	BFG18L/LK40	64
40	22L	19	35	27.5	44.5	42	36	6.4	M6 22	26 2.5	0.24	BFG22L/LK40	64
40	28L	24	35	27.5	44.5	42	41	6.4	M6 22	26 2.5	0.28	BFG28L/LK40	64
55	20S	16	50	39.5	61.0	57	36	8.4	M8 25	32 2.5	0.35	BFG20S/LK55	250

1) Pressure shown = Item deliverable

2) L = light series; S = heavy series

$$\frac{PN \text{ (bar)}}{10} = PN \text{ (MPa)}$$

Delivery without nut and ring.
Information on ordering complete fittings
or alternative sealing materials see page M11.

*Please add the suffixes below according to the material / surface required.

Order code suffixes				
Material	Suffix surface and material	Example only hydraulic flange	Example incl. metr. screws and O-ring	Standard sealing material (no additional suffix needed)
Steel, zinc plated, chrome ⁶ -free	CF	BFG16S/LK35CFX	BFG16S/LK35OMDCF	NBR
Steel, zinc yellow plated	A3C	BFG16S/LK35A3CX	BFG16S/LK35OMDA3C	NBR

BFW Gear pump flange 90° elbow

Hydraulic flange / EO 24° cone end

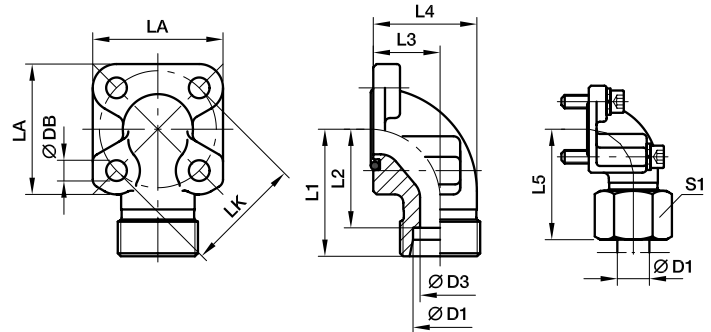

BFW 90° Flange connection EO 24° cone end

LK	D1 ²⁾	D3	L1	L2	L3	L4	L5	LA	S1	DB	Screws		O-ring	Weight (steel) kg/piece	Order code*	PN (bar) ¹⁾
											2 pieces (metr.)	2 pieces (metr.)				
35	10L	8	38	31.0	16.5	26.5	47.0	40	19	6.4	M6 22	M6 35	20 2.5	0.23	BFW10L/LK35	200
35	12L	10	38	31.0	16.5	26.5	47.0	40	22	6.4	M6 22	M6 35	20 2.5	0.26	BFW12L/LK35	200
35	15L	12	38	31.0	16.5	26.5	46.0	40	27	6.4	M6 22	M6 35	20 2.5	0.38	BFW15L/LK35	160
35	16S	12	38	29.5	20.0	31.0	48.0	40	30	6.4	M6 22	M6 40	20 2.5	0.55	BFW16S/LK35	200
35	20S	16	45	34.5	25.0	38.0	56.0	40	36	6.4	M6 22	M6 45	20 2.5	0.65	BFW20S/LK35	200
40	15L	12	38	31.0	22.5	36.5	46.0	42	27	6.4	M6 22	M6 22	26 2.5	0.29	BFW15L/LK40	64
40	18L	15	38	30.5	22.5	36.5	47.0	42	32	6.4	M6 22	M6 22	26 2.5	0.70	BFW18L/LK40	64
40	22L	19	38	30.5	22.5	36.5	47.5	42	36	6.4	M6 22	M6 22	26 2.5	0.36	BFW22L/LK40	64
40	28L	22	40	32.5	28.0	43.0	49.0	42	41	6.4	M6 20	M6 50	26 2.5	0.82	BFW28L/LK40	64
40	35L	31	41	30.5	32.0	55.0	52.0	42	50	6.4	M6 22	M6 60	26 2.5	0.22	BFW35L/LK40	64
40	20S	16	40	29.5	22.5	35.5	50.0	42	36	6.4	M6 22	M6 45	26 2.5	0.23	BFW20S/LK40	160
55	35L	31	49	38.5	32.0	51.5	62.0	58	50	8.4	M8 25	M8 60	32 2.5	0.27	BFW35L/LK55	64
55	42L	38	49	38.0	40.0	64.5	61.0	58	60	8.4	M8 25	M8 70	32 2.5	0.41	BFW42L/LK55	64
55	20S	17	45	34.5	24.0	38.0	56.0	58	36	8.4	M8 25	M8 50	32 2.5	0.94	BFW20S/LK55	160
55	25S	20	49	37.0	30.0	46.0	61.0	58	46	8.4	M8 25	M8 55	32 2.5	0.80	BFW25S/LK55	160
55	30S	26	49	35.5	32.0	50.0	62.0	58	50	8.4	M8 25	M8 50	32 2.5	0.20	BFW30S/LK55	160

1) Pressure shown = Item deliverable

2) L = light series; S = heavy series

$$\frac{\text{PN (bar)}}{10} = \text{PN (MPa)}$$

Delivery without nut and ring.
Information on ordering complete fittings
or alternative sealing materials see page M11.



*Please add the suffixes below according to the material / surface required.

Order code suffixes				
Material	Suffix surface and material	Example only hydraulic flange	Example incl. metr. screws and O-ring	Standard sealing material (no additional suffix needed)
Steel, zinc plated, chrome ⁶ -free	CF	BFW16S/LK35CFX	BFW16S/LK35OMDCF	NBR
Steel, zinc yellow plated	A3C	BFW16S/LK35A3CX	BFW16S/LK35OMDA3C	NBR

BFW3 Gear pump flange 90° elbow 3 holes

Hydraulic flange / EO 24° cone end

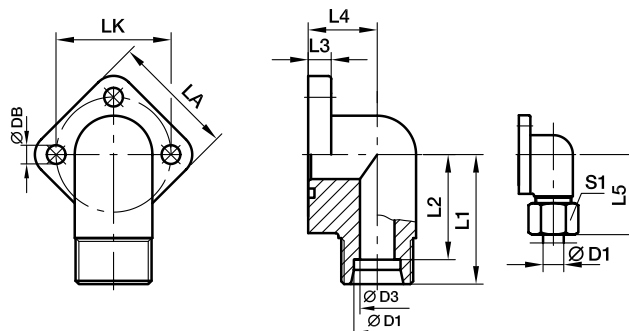

BFW-3 90° Flange connection EO 24° cone end

LK	D1 ²⁾	D3	L1	L2	L3	L4	L5	LA	S1	DB	Screws (metr.)	O-ring	Weight (steel) kg/piece	Order code*	PN (bar) ¹⁾ A3C
30	12L	10	37	30.0	10	37.5	46	38	22	6.4	M6 22	16 2.5	0.13	BFW3-12L/LK30	200
30	15L	12	37	30.0	10	37.5	47	38	27	6.4	M6 22	16 2.5	0.14	BFW3-15L/LK30	200
30	18L	15	37	30.0	10	37.5	47	38	32	6.4	M6 22	16 2.5	0.17	BFW3-18L/LK30	64
40	22L	19	43	35.5	14	41.0	53	48	36	8.4	M8 30	24 2.5	0.29	BFW3-22L/LK40	64
40	28L	24	43	35.5	14	41.0	53	48	41	8.4	M8 30	24 2.5	0.40	BFW3-28L/LK40	64

1) Pressure shown = Item deliverable

2) L = light series

$\frac{PN \text{ (bar)}}{10} = PN \text{ (MPa)}$

Delivery without nut and ring.

Information on ordering complete fittings or alternative sealing materials see page M11.

*Please add the suffixes below according to the material / surface required.

Order code suffixes				
Material	Suffix surface and material	Example only hydraulic flange	Example incl. metr. screws and O-ring	Standard sealing material (no additional suffix needed)
Steel, zinc plated, chrome ⁶ -free	CF	BFW3-12L/LK30CFX	BFW3-12L/LK30OMDCF	NBR
Steel, zinc yellow plated	A3C	BFW3-12L/LK30A3CX	BFW3-12L/LK30OMDA3C	NBR

BFW-G Gear pump flange 90° elbow

Hydraulic flange / BSPP 60° cone end
(ISO 8434-6)

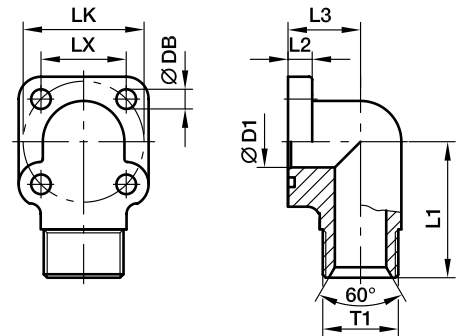

BFW-G 90° BSPP 60° cone end

LK	T1	D1	L1	L2	L3	LX	DB	Screws		O-ring	Weight (steel) kg/piece	Order code*	PN (bar) ¹⁾
								2 pieces (metr.)	2 pieces (metr.)				A3C
35	G3/8	10	40	8	20.0	24.8	6.5	M6 20	M6 35	18.72 2.62	0.22	BFW-G38/LK35	315
35	G1/2	12	40	8	20.0	24.8	6.5	M6 20	M6 35	18.72 2.62	0.24	BFW-G12/LK35	315
35	G3/4	15	40	8	20.0	24.8	6.5	M6 20	M6 40	18.72 2.62	0.26	BFW-G34/LK35	315
40	G3/8	10	40	8	22.5	28.2	6.5	M6 20	M6 40	25.07 2.62	0.30	BFW-G38/LK40	250
40	G1/2	12	40	8	22.5	28.2	6.5	M6 20	M6 40	25.07 2.62	0.32	BFW-G12/LK40	250
40	G3/4	17	40	8	22.5	28.2	6.5	M6 20	M6 40	25.07 2.62	0.34	BFW-G34/LK40	250
40	G1	19	40	8	28.0	28.2	6.5	M6 20	M6 50	25.07 2.62	0.36	BFW-G1/LK40	250
55	G1/2	12	49	12	24.0	38.8	8.5	M8 25	M8 45	31.42 2.62	0.35	BFW-G12/LK55	250
55	G3/4	17	46	12	24.0	38.8	8.5	M8 25	M8 60	31.42 2.62	0.40	BFW-G34/LK55	250
55	G1	22	49	12	31.0	38.8	8.5	M8 25	M8 70	31.42 2.62	0.45	BFW-G1/LK55	250

1) Pressure shown = Item deliverable

$\frac{\text{PN (bar)}}{10} = \text{PN (MPa)}$

*Please add the suffixes below according to the material / surface required.

Order code suffixes				
Material	Suffix surface and material	Example only hydraulic flange	Example incl. metr. screws and O-ring	Standard sealing material (no additional suffix needed)
Steel, zinc plated, chrome ⁶ -free	CF	BFW-G38/LK35CF	BFW-G38/LK35CFM	NBR
Steel, zinc yellow plated	A3C	BFW-G38/LK35A3C	BFW-G38/LK35A3CM	NBR

BFW-GI Gear pump flange 90° elbow

Hydraulic flange / Female BSPP thread
(ISO 1179-1)

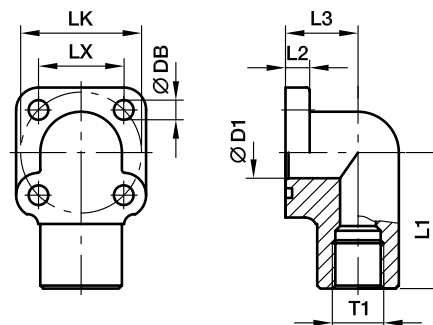

BFW-GI 90° Female BSPP thread

LK	T1	D1	L1	L2	L3	LX	DB	Screws		O-ring	Weight (steel) kg/piece	Order code*	PN (bar) ¹⁾	
								2 pieces (metr.)	2 pieces (metr.)				A3C	
35	G3/8	10	40	8	20.0	24.8	6.5	M6 20	M6 35	18.72 2.62	0.22	BFW-GI38/LK35		315
35	G1/2	12	40	8	20.0	24.8	6.5	M6 20	M6 35	18.72 2.62	0.24	BFW-GI12/LK35		315
40	G3/8	10	40	8	22.5	28.2	6.5	M6 20	M6 40	25.07 2.62	0.30	BFW-GI38/LK40		250
40	G1/2	12	40	8	22.5	28.2	6.5	M6 20	M6 40	25.07 2.62	0.32	BFW-GI12/LK40		250
40	G3/4	17	40	8	22.5	28.2	6.5	M6 20	M6 40	25.07 2.62	0.34	BFW-GI34/LK40		250
55	G1/2	12	49	12	24.0	38.8	8.5	M8 25	M8 45	31.42 2.62	0.35	BFW-GI12/LK55		250
55	G3/4	17	46	12	24.0	38.8	8.5	M8 25	M8 60	31.42 2.62	0.40	BFW-GI34/LK55		250
55	G1	22	49	12	31.0	38.8	8.5	M8 25	M8 70	31.42 2.62	0.45	BFW-GI11/LK55		250

¹⁾ Pressure shown = Item deliverable

$$\frac{\text{PN (bar)}}{10} = \text{PN (MPa)}$$

*Please add the suffixes below according to the material / surface required.

Order code suffixes				
Material	Suffix surface and material	Example only hydraulic flange	Example incl. metr. screws and O-ring	Standard sealing material (no additional suffix needed)
Steel, zinc plated, chrome ⁶ -free	CF	BFW-GI38/LK35CF	BFW-GI38/LK35CFM	NBR
Steel, zinc yellow plated	A3C	BFW-GI38/LK35A3C	BFW-GI38/LK35A3CM	NBR

BFW-S Gear pump flange 90° elbow

Hydraulic flange / Socket weld end

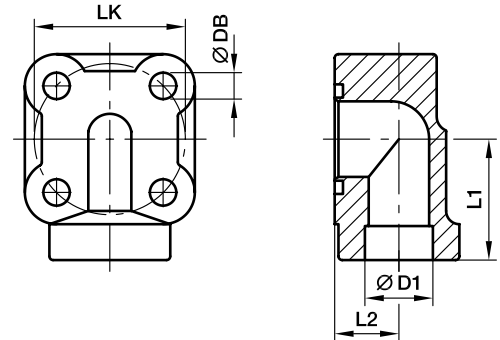

BFW-S 90° Socket weld end

LK	D1	L1	L2	DB	Screws (metr.)	O-ring	Weight (steel) kg/piece	Order code*	PN (bar) ¹⁾ S
30	12	30	14	7.0	M 6 30	15.88 2.62	0.15	BFW-S12/LK30/M6	200
30	12	27	13	8.5	M 8 35	15.88 2.62	0.15	BFW-S12/LK30/M8	250
30	14	27	13	6.5	M 6 30	15.88 2.62	0.14	BFW-S14/LK30/M6	200
30	14	27	13	8.5	M 8 35	15.88 2.62	0.14	BFW-S14/LK30/M8	250
30	16	27	13	6.5	M 6 30	15.88 2.62	0.12	BFW-S16/LK30/M6	200
30	16	27	13	8.5	M 8 35	15.88 2.62	0.12	BFW-S16/LK30/M8	250
30	18	27	13	6.5	M 6 30	15.88 2.62	0.10	BFW-S18/LK30/M6	200
35	14	30	12	6.5	M 6 35	18.72 2.62	0.20	BFW-S14/LK35/M6	200
35	14	30	14	8.5	M 8 40	18.72 2.62	0.20	BFW-S14/LK35/M8	250
35	16	30	12	6.5	M 6 35	18.72 2.62	0.18	BFW-S16/LK35/M6	200
35	16	30	14	8.5	M 8 40	18.72 2.62	0.18	BFW-S16/LK35/M8	250
35	18	30	14	6.5	M 6 35	18.72 2.62	0.18	BFW-S18/LK35/M6	200
35	18	30	14	8.5	M 8 40	18.72 2.62	0.18	BFW-S18/LK35/M8	250
35	20	30	14	6.5	M 6 35	18.72 2.62	0.17	BFW-S20/LK35/M6	200
40	18	32	17	6.5	M 6 40	23.81 2.62	0.25	BFW-S18/LK40/M6	200
40	18	32	17	8.5	M 8 40	23.81 2.62	0.25	BFW-S18/LK40/M8	250
40	20	32	17	6.5	M 6 40	23.81 2.62	0.24	BFW-S20/LK40/M6	200
40	20	32	17	8.5	M 8 40	23.81 2.62	0.24	BFW-S20/LK40/M8	250
40	22	32	17	6.5	M 6 40	23.81 2.62	0.23	BFW-S22/LK40/M6	200
40	22	32	17	8.5	M 8 40	23.81 2.62	0.23	BFW-S22/LK40/M8	250
40	25	32	17	6.5	M 6 40	23.81 2.62	0.22	BFW-S25/LK40/M6	200
40	25	32	17	8.5	M 8 40	23.81 2.62	0.22	BFW-S25/LK40/M8	250

¹⁾ Pressure shown = Item deliverable

$$\frac{PN \text{ (bar)}}{10} = PN \text{ (MPa)}$$

The pressures given here are the maximum allowable for the flange fittings. If the pipe or tube used has a lower pressure rating, then the welded assembly rating will be the lower one, assuming the weld is adequately strong.

*Please add the suffixes below according to the material / surface required.

Order code suffixes			
Material	Suffix surface and material	Example incl. metr. screws and O-ring	Standard sealing material (no additional suffix needed)
Steel, blanc oil dipped	S	BFW-S16/LK30/M6SM	NBR

PF Gear pump flange straight

Hydraulic flange / Female BSP thread
(ISO 1179-1)

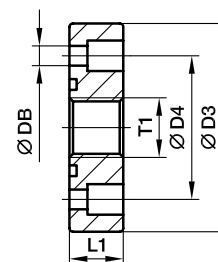

PF

Pump size	LK	T1	D3	D4	L1	DB	Screws (metr.)	O-ring	Weight (steel) kg/piece	Order code*	PN (bar) ¹⁾ A3K
1.0	30.0	G3/8	45	30.0	13	6.5	M 6 16	18.77 1.78	0.10	PF1	250
2.0	40.0	G1/2	58	40.0	15	8.5	M 8 20	25.12 1.78	0.21	PF2	250
3.0	51.0	G3/4	75	51.0	18	10.5	M10 25	31.42 2.62	0.48	PF3	250
3B	56.0	G3/4	76	56.0	18	10.5	M10 25	31.42 2.62	0.48	PF3B	250
3.5	62.0	G1	88	62.0	20	10.5	M10 25	39.69 3.53	0.53	PF3.5	180
3.5B	62.0	G1	88	62.0	20	12.5	M12 25	39.69 3.53	0.59	PF3.5B	180
4.0	72.5	G1 1/4	98	72.5	22	12.5	M12 30	47.22 3.53	0.64	PF4	180

PFL Gear pump flange straight

Hydraulic flange / Female BSP thread – long version
(ISO 1179-1)

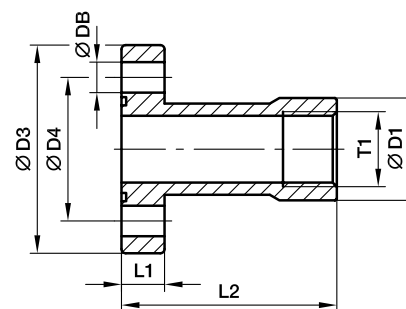

PFL

Pump size	LK	T1	D1	D3	D4	L1	L2	DB	Screws (metr.)	O-ring	Weight (steel) kg/piece	Order code*	PN (bar) ¹⁾ A3K
1.0	30.0	G3/8	23.0	45	30.0	10	55	6.5	M 6 20	18.77 1.78	0.15	PFL1	250
2.0	40.0	G1/2	26.5	58	40.0	12	60	8.5	M 8 25	25.12 1.78	0.27	PFL2	250
3.0	51.0	G3/4	33.5	76	51.0	16	72	10.5	M10 35	31.42 2.62	0.59	PFL3	250
3B	56.0	G3/4	33.5	76	56.0	19	72	10.5	M10 35	31.42 2.62	0.69	PFL3.5	250

¹⁾ Pressure shown = Item deliverable

$$\frac{\text{PN (bar)}}{10} = \text{PN (MPa)}$$

*Please add the suffixes below according to the material / surface required.

Order code suffixes			
Material	Suffix surface and material	Example incl. metr. screws and O-ring	Standard sealing material (no additional suffix needed)
Steel, zinc silver plated PF	A3K	PF1A3KM	NBR
Steel, zinc silver plated PFL	A3K	PFL1A3KM	NBR

PFE Gear pump flange straight

Hydraulic flange / BSPP 60° cone end
(ISO 8434-6)

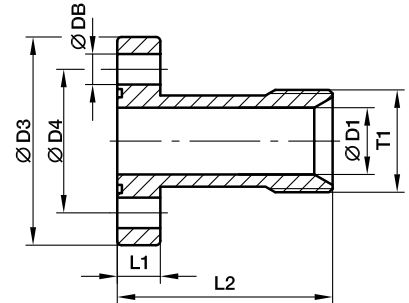

PFE

Pump size	LK	T1	D1	D3	D4	L1	L2	DB	Screws (metr.)	O-ring	Weight (steel) kg/piece	Order code*	PN (bar) ¹⁾ A3K
1.0	30.0	G1/2	14.0	45	30.0	10	55	6.5	M 6 20	18.77 1.78	0.15	PFE1	250
2.0	40.0	G3/4	19.0	58	40.0	12	60	8.5	M 8 25	25.12 1.78	0.27	PFE2	250
3.0	51.0	G1	24.0	76	51.0	16	72	10.5	M10 35	31.42 2.62	0.59	PFE3	250
3B	56.0	G1	24.0	76	56.0	16	72	10.5	M10 35	31.42 2.62	0.69	PFE3.5	250

PFB Gear pump flange straight

Hydraulic flange / Butt weld tube end

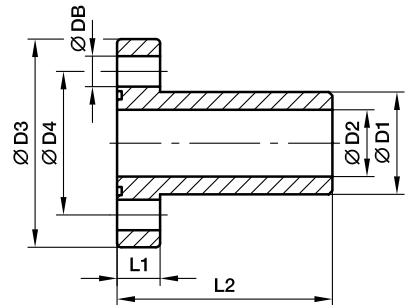

PFB

Pump size	LK	D1	D2	D3	D4	L1	L2	DB	Screws (metr.)	O-ring	Weight (steel) kg/piece	Order code*	PN (bar) ¹⁾ S
1.0	30.0	19.5	14.0	45	30.0	10	55	6.5	M 6 20	18.77 1.78	0.15	PFB1	250
2.0	40.0	25.4	19.0	58	40.0	12	60	8.5	M 8 25	25.12 1.78	0.27	PFB2	250
3.0	51.0	32.0	24.5	76	51.0	16	72	10.5	M10 35	31.42 2.62	0.59	PFB3	250
3B	56.0	32.0	24.5	76	56.0	16	72	10.5	M10 35	31.42 2.62	0.69	PFB3.5	250

1) Pressure shown = Item deliverable

$$\frac{PN \text{ (bar)}}{10} = PN \text{ (MPa)}$$

The pressures (**PFB**) given here are the maximum allowable for the flange fittings. If the pipe or tube used has a lower pressure rating, then the welded assembly rating will be the lower one, assuming the weld is adequately strong.

*Please add the suffixes below according to the material / surface required.

Order code suffixes			
Material	Suffix surface and material	Example incl. metr. screws and O-ring	Standard sealing material (no additional suffix needed)
Steel, zinc silver plated PFE	A3K	PFE1A3KM	NBR
Steel, blanc oil dipped PFB	S	PFB1SM	NBR



BFW3-G Gear pump flange 90° elbow 3 holes

Hydraulic flange / Female BSW thread
(ISO 1179-1)

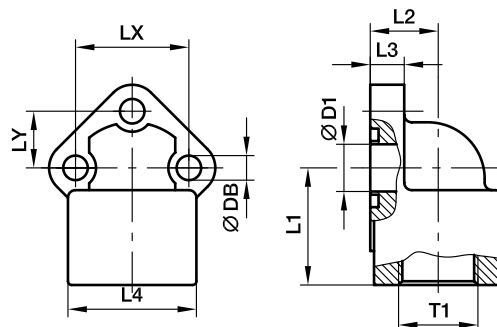

PWDS Female BSW thread

Pump size	LK	T1	D1	L1	L2	L3	L4	LX	LY	DB	Screws (metr.)	O-ring	Weight (steel) kg/piece	Order code*	PN (bar) ¹⁾ A3K
0.5	26.0	3/8	11	28	17	9.0	30	26.0	13.0	5.5	M 5 18	15.60 1.78	0.16	BFW3-G38/LK26	315
0.5	26.0	1/2	11	28	17	9.0	30	26.0	13.0	5.5	M 5 18	15.60 1.78	0.15	BFW3-G12/LK26	315
1.0	30.0	3/8	12	30	17	9.0	30	30.0	15.0	6.5	M 6 20	15.88 2.62	0.16	BFW3-G38/LK30	315
1.0	30.0	1/2	12	30	17	9.0	30	30.0	15.0	6.5	M 6 20	15.88 2.62	0.15	BFW3-G12/LK30	315
2.0	40.0	1/2	18	36	23	11.5	36	40.0	20.0	8.5	M 8 25	23.81 2.62	0.33	BFW3-G12/LK40	315
2.0	40.0	3/4	18	36	23	11.5	36	40.0	20.0	8.5	M 8 25	23.81 2.62	0.31	BFW3-G34/LK40	315
3.0	51.0	3/4	24	46	26	13.0	45	51.0	25.5	10.5	M10 30	29.75 3.53	0.57	BFW3-G34/LK51	315
3.0	51.0	1	24	46	26	13.0	45	51.0	25.5	10.5	M10 30	29.75 3.53	0.52	BFW3-G1/LK51	315
3B	56.0	3/4	24	46	26	13.0	45	56.0	28.0	10.5	M10 30	29.75 3.53	0.57	BFW3-G34/LK56	315
3B	56.0	1	24	46	26	13.0	45	56.0	28.0	10.5	M10 30	29.75 3.53	0.52	BFW3-G1/LK56	315
3.5	62.0	1 1/4	31	55	35	14.0	55	62.0	31.0	11.0	M10 30	37.69 3.53	0.74	BFW3-G114/LK62	315
3.5	62.0	1	25	55	35	14.0	55	62.0	31.0	11.0	M10 30	37.69 3.53	0.73	BFW3-G1/LK62	315
3.5	62.0	1 1/4	31	55	35	14.0	55	62.0	31.0	13.0	M12 35	37.69 3.53	0.74	BFW3-G114/LK62/12	315
3.5	62.0	1	25	55	35	14.0	55	62.0	31.0	13.0	M12 35	37.69 3.53	0.73	BFW3-G1/LK62/12	315
4.0	72.5	1 1/2	38	58	38	15.0	62	72.5	36.2	13.0	M12 35	47.22 3.53	0.95	BFW3-G112/LK72.5	315
4.0	72.5	1 1/4	31	58	38	15.0	62	72.5	36.2	13.0	M12 35	47.22 3.53	0.93	BFW3-G114/LK72.5	315

1) Pressure shown = Item deliverable

$$\frac{PN \text{ (bar)}}{10} = PN \text{ (MPa)}$$

*Please add the suffixes below according to the material / surface required.

Order code suffixes				
Material	Suffix surface and material	Example only hydraulic flange	Example incl. metr. screws and O-ring	Standard sealing material (no additional suffix needed)
Steel, zinc silver plated	A3K	BFW3-G38/LK26A3K	BFW3-G38/LK26A3KM	NBR

PWDS-G Gear pump flange 90° elbow 4 holes – aluminium

Hydraulic flange / Female BSPP thread
(ISO 1179-1)

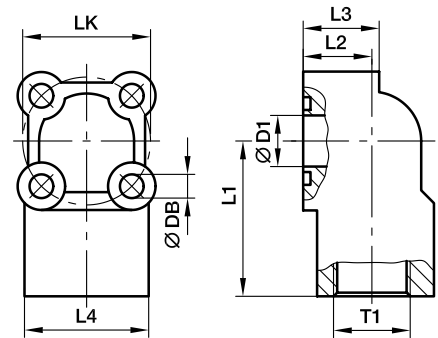

PWDS-G 90° Female BSPP thread

LK	T1	D1	L1	L2	L3	L4	DB	Screws		O-ring	Weight (steel) kg/piece	Order code*	PN (bar) ¹⁾
								2 pieces (metr.)	2 pieces (metr.)				A
30	G3/8	11.5	39.0	18	20	33	6.5	M6 30	M6 40	15.88 2.62	0.09	PWDS-G38/LK30	180
30	G1/2	11.5	39.0	18	20	33	6.5	M6 30	M6 40	15.88 2.62	0.09	PWDS-G12/LK30	180
35	G3/8	14.0	42.5	18	20	34	6.5	M6 30	M6 40	18.72 2.62	0.11	PWDS-G38/LK35	180
35	G1/2	14.0	42.5	18	20	34	6.5	M6 30	M6 40	18.72 2.62	0.11	PWDS-G12/LK35	180
40	G1/2	18.0	47.5	24	28	41	6.5	M6 40	M6 50	22.22 2.62	0.18	PWDS-G12/LK40	180
40	G3/4	18.0	47.5	24	28	41	6.5	M6 40	M6 50	22.22 2.62	0.18	PWDS-G34/LK40	180
55	G3/4	24.5	54.0	29	31	49	8.5	M8 45	M8 60	29.75 3.53	0.31	PWDS-G34/LK55	180
55	G1	24.5	54.0	29	31	49	8.5	M8 45	M8 60	29.75 3.53	0.30	PWDS-G1/LK55	180

1) Pressure shown = Item deliverable

$$\frac{PN \text{ (bar)}}{10} = PN \text{ (MPa)}$$

*Please add the suffixes below according to the material / surface required.

Order code suffixes			
Material	Suffix surface and material	Example incl. metr. screws and O-ring	Standard sealing material (no additional suffix needed)
Aluminium	A	PWDS-G38/LK30AM	NBR

PWDA Gear pump flange 90° elbow 3 holes – aluminium

Hydraulic flange / Female BSPP thread
(ISO 1179-1)

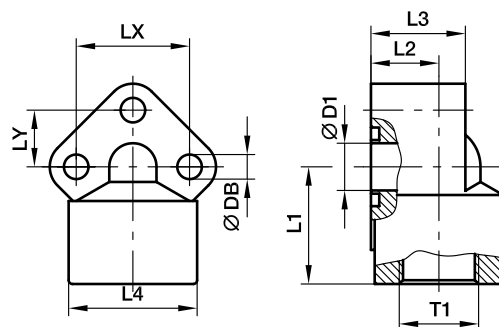

PWDA 90° Female BSPP thread

Pump size	LK	T1	D1	L1	L2	L3	L4	LX	LY	DB	Screws (metr.)	O-ring	Weight (steel) kg/piece	Order code*	PN (bar) ¹⁾
															A
0.5	26	G3/8	10.0	31	18.0	25	31	26	13.0	5.5	M 5 35	14 1.78	0.06	PWDA-05/38	180
0.5	26	G1/2	10.0	31	18.0	25	31	26	13.0	5.5	M 5 35	14 1.78	0.06	PWDA-05/12	180
1.0	30	G3/8	12.5	31	18.0	26	34	30	15.0	6.5	M 6 35	15.88 2.62	0.08	PWDA-1/38	180
1.0	30	G1/2	12.5	31	18.0	26	34	30	15.0	6.5	M 6 35	15.88 2.62	0.08	PWDA-1/12	180
2.0	40	G1/2	18.0	40	21.5	31	42	40	20.0	8.5	M 8 45	22.22 2.62	0.15	PWDA-2/12	180
2.0	40	G3/4	18.0	40	21.5	31	42	40	20.0	8.5	M 8 45	22.22 2.62	0.15	PWDA-2/34	180
3.0*	56	G3/4	24.5	46	26.0	42	49	56	25.5-28	11.0	M10 60	29.75 3.53	0.32	PWDA-3/34	180
3.0*	56	G1	24.5	46	26.0	42	49	56	25.5-28	11.0	M10 60	29.75 3.53	0.32	PWDA-3/100	180

1) Pressure shown = Item deliverable

*Oval drill hole

$$\frac{PN \text{ (bar)}}{10} = PN \text{ (MPa)}$$

*Please add the suffixes below according to the material / surface required.

Order code suffixes			
Material	Suffix surface and material	Example incl. metr. screws and O-ring	Standard sealing material (no additional suffix needed)
Aluminium	A	PWDA-05/38AM	NBR

PSFC Square flange clamp

ISO 6164

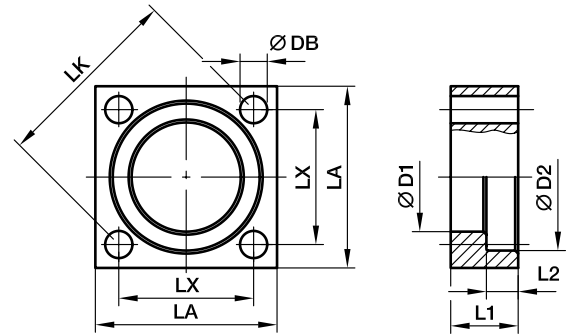

250 bar Series

Series ²⁾	Nom. flange size		LK	D1	D2	L1	L2	LA	LX	DB	Weight (steel) kg/piece	Order code*	PN (bar) ¹⁾
	SAE (in)	ISO (DN)											S
L	3/8	10	35	18.5	25.0	18	6.2	40	24.7	6.6	0.07	PSFC/L/10	250
L	1/2	13	42	24.3	31.0	20	6.2	45	29.7	9.0	0.08	PSFC/L/13	250
L	3/4	19	50	32.2	38.9	22	6.2	50	35.4	9.0	0.12	PSFC/L/19	250
L	1	25	62	38.5	45.3	25	7.5	65	43.8	11.0	0.24	PSFC/L/25	250
L	1 1/4	32	73	43.7	51.6	30	7.5	75	51.6	13.5	0.35	PSFC/L/32	250
L	1 1/2	38	85	50.8	61.1	36	7.5	90	60.1	17.5	0.51	PSFC/L/38	250
L	2	51	98	62.8	72.3	40	9.0	100	69.3	17.5	0.88	PSFC/L/51	250
L	2 1/2	56	118	76.6	88.0	45	9.0	120	83.4	22.0	1.53	PSFC/L/56	250
L	3	63	145	90.8	102.3	52	9.0	140	102.5	22.0	2.31	PSFC/L/63	250
L	4	80	160	114.5	132.0	60	21.0	160	113.5	25.0	4.19	PSFC/L/80	250

400 bar Series

S	3/8	10	35	18.5	26.4	18	7.2	40	24.7	6.6	0.08	PSFC/S/10	400
S	1/2	13	42	24.7	32.6	20	7.2	45	29.7	9.0	0.12	PSFC/S/13	400
S	3/4	19	50	32.5	42.1	22	8.2	50	35.4	9.0	0.17	PSFC/S/19	400
S	1	25	62	38.9	48.4	25	9.0	65	43.8	1.0	0.32	PSFC/S/25	400
S	1 1/4	32	73	44.6	54.8	30	9.8	75	51.6	13.5	0.46	PSFC/S/32	400
S	1 1/2	38	85	51.6	64.3	36	12.0	90	60.1	17.5	0.69	PSFC/S/38	400
S	2	51	98	67.6	80.2	40	12.0	100	69.3	17.5	1.18	PSFC/S/51	400
S	2 1/2	56	118	80.5	95.0	50	16.1	120	83.4	22.0	1.97	PSFC/S/56	400
S	3	63	145	90.5	111.0	52	16.1	150	102.5	26.0	2.81	PSFC/S/63	400
S	3 1/2	70	160	102.5	120.0	60	17.5	160	113.1	26.0	3.09	PSFC/S/70	400
S	4	80	175	114.5	136.0	70	21.0	180	123.7	33.0	4.88	PSFC/S/80	350

¹⁾ Pressure shown = item deliverable

²⁾ L = light series; S = heavy series

$$\frac{PN \text{ (bar)}}{10} = PN \text{ (MPa)}$$

The pressures given here are the maximum allowable for the flange fittings. If the pipe or tube used has a lower pressure rating, then the welded assembly rating will be the lower one, assuming the weld is adequately strong.

*Please add the suffixes below according to the material / surface required.

Order code suffixes			
Material	Suffix surface and material	Example	Description
Steel, blanc oil dipped	S	PSFC/L/10S	only flange clamp



PSFA-B Square flange adapter (butt weld)

Square flange / Butt weld end
(ISO 6164)

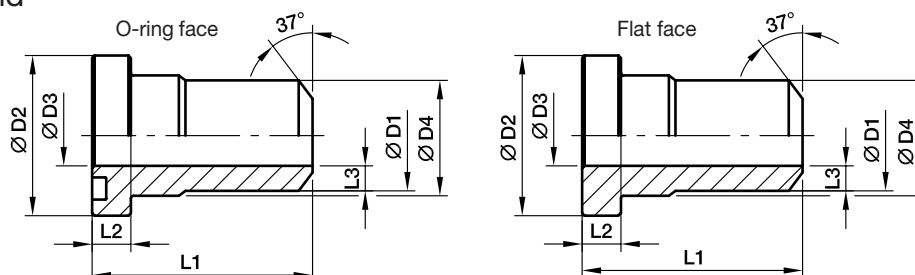

250 bar Series

Nom. flange size			D1	D2	D3	D4	L1	L2	L3	O-ring	Weight (steel) kg/piece	O-ring face Order code*	Flat face Order code*	PN (bar) ¹⁾ S	
Series ²⁾	SAE (in)	ISO (DN)													
L	3/8	10	17.5	24.5	10	18.0	40	6.8	3.75	17.13	2.62	0.09	PSFA10/L/17.5B	PSCFA10/L/17.5B	250
L	1/2	13	21.6	30.2	13	24.0	50	6.8	4.30	18.64	3.53	0.12	PSFA13/L/21.6B	PSCFA13/L/21.6B	250
L	3/4	19	27.2	38.1	19	31.5	60	6.8	4.10	24.99	3.53	0.18	PSFA19/L/27.2B	PSCFA19/L/27.2B	250
L	1	25	34.5	44.5	25	38.0	70	8.0	4.75	32.93	3.53	0.35	PSFA25/L/34.5B	PSCFA25/L/34.5B	250
L	1 1/4	32	43.0	50.8	31	43.0	80	8.0	6.00	37.89	3.53	0.50	PSFA32/L/43B	PSCFA32/L/43B	250
L	1 1/2	38	48.6	60.4	38	50.0	90	8.0	5.30	47.22	3.53	0.74	PSFA38/L/48.6B	PSCFA38/L/48.6B	250
L	2	51	61.0	71.4	50	62.0	100	9.6	5.50	56.74	3.53	1.27	PSFA51/L/61B	PSCFA51/L/61B	250
L	2 1/2	56	76.6	87.2	63	76.0	110	12.0	6.80	69.44	3.53	2.20	PSFA56/L/76.6B	PSCFA56/L/76.6B	250
L	3	63	89.0	101.6	70	90.0	120	15.0	9.50	85.32	3.53	3.32	PSFA63/L/89B	PSCFA63/L/89B	250
L	4	80	114.0	131.0	90	114.0	140	23.5	12.00	97.79	5.34	6.03	PSFA80/L/114B	PSCFA80/L/114B	250

400 bar Series

S	3/8	10	17.5	26.0	10	18.0	40	7.8	3.75	17.13	2.62	0.11	PSFA10/S/17.5B	PSCFA10/S/17.5B	400
S	1/2	13	21.6	31.8	13	24.0	50	7.8	4.30	18.64	3.53	0.17	PSFA13/S/21.6B	PSCFA13/S/21.6B	400
S	3/4	19	27.2	41.3	18	32.0	60	8.8	4.60	24.99	3.53	0.25	PSFA19/S/27.2B	PSCFA19/S/27.2B	400
S	1	25	34.5	47.6	22	38.0	70	9.5	6.25	32.93	3.53	0.46	PSFA25/S/34.5B	PSCFA25/S/34.5B	400
S	1 1/4	32	43.0	54.0	28	44.0	90	10.3	7.50	37.89	3.53	0.65	PSFA32/S/43B	PSCFA32/S/43B	400
S	1 1/2	38	48.6	63.5	32	51.0	90	12.6	8.30	47.22	3.53	0.99	PSFA38/S/48.6B	PSCFA38/S/48.6B	400
S	2	51	61.0	79.4	41	67.0	100	12.6	10.00	56.52	5.34	1.69	PSFA51/S/61B	PSCFA51/S/61B	400
S	2 1/2	56	76.6	94.2	50	90.0	110	16.5	13.30	69.22	5.34	2.83	PSFA56/S/76.6B	PSCFA56/S/76.6B	400
S	3	63	89.0	104.0	58	90.0	120	18.0	15.50	75.57	5.34	4.04	PSFA63/S/89B	PSCFA63/S/89B	400
S	3 1/2	70	102.0	119.0	63	102.0	130	20.0	19.50	85.09	5.34	4.45	PSFA70/S/102B	PSCFA70/S/102B	400
S	4	80	114.0	131.0	74	114.0	140	23.5	20.00	88.27	5.34	7.01	PSFA80/S/114B	PSCFA80/S/114B	350

¹⁾ Pressure shown = item deliverable

²⁾ L = light series; S = heavy series

$\frac{PN \text{ (bar)}}{10} = PN \text{ (MPa)}$

The pressures given here are the maximum allowable for the flange fittings. If the pipe or tube used has a lower pressure rating, then the welded assembly rating will be the lower one, assuming the weld is adequately strong.

*Please add the suffixes below according to the material / surface required.

Order code suffixes			
Material	Suffix surface and material	Example	Description
Steel, blanc oil dipped	S	PSFA10/L/17.5BS	only flange adapter

PSFP Square flange plug

ISO 6164

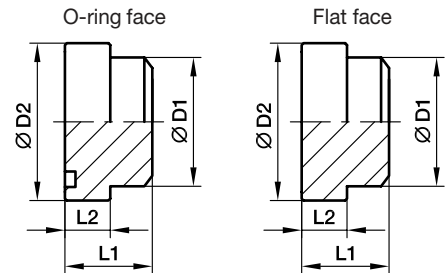
250 bar Series

Series ²⁾	Nom. flange size		D1	D2	L1	L2	O-ring	Weight (steel) kg/piece	O-ring face Order code*	Flat face Order code*	PN (bar) ¹⁾
	SAE (in)	ISO (DN)									S
L	3/8	10	18.0	24.5	6.8	18.0	17.13 2.62	0.07	PSFP10/L/18B	PSCFP10/L/18B	250
L	1/2	13	24.0	30.2	6.8	20.0	18.64 3.53	0.08	PSFP13/L/24B	PSCFP13/L/24B	250
L	3/4	19	31.5	38.1	6.8	22.0	24.99 3.53	0.12	PSFP19/L/31.5B	PSCFP19/L/31.5B	250
L	1	25	38.0	44.5	8.0	25.0	32.93 3.53	0.24	PSFP25/L/38B	PSCFP25/L/38B	250
L	1 1/4	32	43.0	50.8	8.0	30.0	37.89 3.53	0.35	PSFP32/L/43B	PSCFP32/L/43B	250
L	1 1/2	38	50.0	60.4	8.0	36.0	47.22 3.53	0.51	PSFP38/L/50B	PSCFP38/L/50B	250
L	2	51	62.0	71.4	9.6	40.0	56.74 3.53	0.88	PSFP51/L/62B	PSCFP51/L/62B	250
L	2 1/2	56	76.0	87.2	12.0	45.0	69.44 3.53	1.53	PSFP56/L/76B	PSCFP56/L/76B	250
L	3	63	90.0	101.6	15.0	52.0	85.32 3.53	2.31	PSFP63/L/90B	PSCFP63/L/90B	250
L	4	80	114.0	131.0	23.5	61.5	97.79 5.34	4.19	PSFP80/L/114B	PSCFP80/L/114B	250

400 bar Series

S	3/8	10	18.0	26.0	7.8	18.0	17.13 2.62	0.08	PSFP10/S/18B	PSCFP10/S/18B	400
S	1/2	13	24.0	31.8	7.8	20.0	18.64 3.53	0.12	PSFP13/S/24B	PSCFP13/S/24B	400
S	3/4	19	32.0	41.3	8.8	22.0	24.99 3.53	0.17	PSFP19/S/32B	PSCFP19/S/32B	400
S	1	25	38.0	47.6	9.5	25.0	32.93 3.53	0.32	PSFP25/S/38B	PSCFP25/S/38B	400
S	1 1/4	32	44.0	54.0	10.3	30.0	37.89 3.53	0.46	PSFP32/S/44B	PSCFP32/S/44B	400
S	1 1/2	38	51.0	63.5	12.6	36.0	47.22 3.53	0.69	PSFP38/S/51B	PSCFP38/S/51B	400
S	2	51	67.0	79.4	12.6	40.0	56.52 5.34	1.18	PSFP51/S/67B	PSCFP51/S/67B	400
S	2 1/2	56	80.0	94.2	16.5	45.0	69.22 5.34	1.97	PSFP56/S/80B	PSCFP56/S/80B	400
S	3	63	90.0	104.0	18.0	52.0	75.57 5.34	2.81	PSFP63/S/90B	PSCFP63/S/90B	400
S	3 1/2	70	102.0	119.0	20.0	60.0	85.09 5.34	3.09	PSFP70/S/102B	PSCFP70/S/102B	400
S	4	80	114.0	131.0	23.5	70.0	88.27 5.34	4.88	PSFP80/S/114B	PSCFP80/S/114B	350

1) Pressure shown = item deliverable

2) L = light series; S = heavy series

$$\frac{PN(\text{bar})}{10} = PN(\text{MPa})$$

The pressures given here are the maximum allowable for the flange fittings. If the pipe or tube used has a lower pressure rating, then the welded assembly rating will be the lower one, assuming the weld is adequately strong.

*Please add the suffixes below according to the material / surface required.

Order code suffixes			
Material	Suffix surface and material	Example	Description
Steel, blanc oil dipped	S	PSFP10/L/18BS	only flange plug

PSF-B Square flange (butt weld adapter coupling)

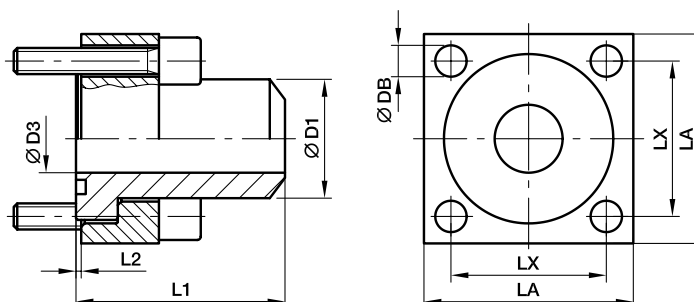
 Square flange / Butt weld end
(ISO 6164)

250 bar Series

Series ²⁾	Nom. flange size		D1	D3	L1	L2	LA	LX	DB	Screws (metr.)	O-ring	Weight (steel) kg/piece	Order code*	PN (bar) ¹⁾
	SAE (in)	ISO (DN)												S
L	3/8	10	17.5	10	40	0.4	40	24.7	6.6	M 6 30	17.13 2.62	0.17	PSF10/L/17.5B	250
L	1/2	13	21.6	13	50	0.4	45	29.7	9.0	M 8 35	18.64 3.53	0.22	PSF13/L/21.6B	250
L	3/4	19	27.2	19	60	0.4	50	35.4	9.0	M 8 35	24.99 3.53	0.32	PSF19/L/27.2B	250
L	1	25	34.5	25	70	0.5	65	43.8	11.0	M10 40	32.93 3.53	0.63	PSF25/L/34.5B	250
L	1 1/4	32	43.0	31	80	0.5	75	51.6	13.5	M12 50	37.89 3.53	0.92	PSF32/L/43B	250
L	1 1/2	38	48.6	38	90	0.5	90	60.1	17.5	M16 60	47.22 3.53	1.34	PSF38/L/48.6B	250
L	2	51	61.0	50	100	0.6	100	69.3	17.5	M16 70	56.74 3.53	2.30	PSF51/L/61B	250
L	2 1/2	56	76.6	63	110	3.0	120	83.4	22.0	M20 80	69.44 3.53	4.00	PSF56/L/76.6B	250
L	3	63	89.0	70	120	6.0	140	102.5	22.0	M20 90	85.32 3.53	6.03	PSF63/L/89B	250
L	4	80	114.0	90	140	2.5	160	113.5	25.0	M24 100	97.79 5.34	10.96	PSF80/L/114B	250

400 bar Series

S	3/8	10	17.5	10	40	0.6	40	24.7	6.6	M 6 30	17.13 2.62	0.20	PSF10/S/17.5B	400
S	1/2	13	21.6	13	50	0.6	45	29.7	9.0	M 8 35	18.64 3.53	0.31	PSF13/S/21.6B	400
S	3/4	19	27.2	18	60	0.6	50	35.4	9.0	M 8 35	24.99 3.53	0.45	PSF19/S/27.2B	400
S	1	25	34.5	22	70	0.5	65	43.8	11.0	M10 40	32.93 3.53	0.83	PSF25/S/34.5B	400
S	1 1/4	32	43.0	28	90	0.5	75	51.6	13.5	M12 50	37.89 3.53	1.19	PSF32/S/43B	400
S	1 1/2	38	48.6	32	90	0.6	90	60.1	17.5	M16 60	47.22 3.53	1.80	PSF38/S/48.6B	400
S	2	51	61.0	41	100	0.6	100	69.3	17.5	M16 70	56.52 5.34	3.08	PSF51/S/61B	400
S	2 1/2	56	76.6	50	110	0.4	120	83.4	22.0	M20 80	69.22 5.34	5.14	PSF56/S/76.6B	400
S	3	63	89.0	58	120	1.9	150	102.5	26.0	M24 90	75.57 5.34	7.34	PSF63/S/89B	400
S	3 1/2	70	102.0	63	130	2.5	160	113.1	26.0	M24 100	85.09 5.34	8.09	PSF70/S/102B	400
S	4	80	114.0	74	140	2.5	180	123.7	33.0	M30 120	88.27 5.34	12.75	PSF80/S/114B	350

1) Pressure shown = item deliverable

2) L = light series; S = heavy series

$$\frac{\text{PN (bar)}}{10} = \text{PN (MPa)}$$

The pressures given here are the maximum allowable for the flange fittings. If the pipe or tube used has a lower pressure rating, then the welded assembly rating will be the lower one, assuming the weld is adequately strong.

*Please add the suffixes below according to the material / surface required.

Order code suffixes			
Material	Suffix surface and material	Example incl. flange clamp, metr. screws and O-ring	Standard sealing material (no additional suffix needed)
Steel, blanc oil dipped	S	PSF10/L/17.5BS	NBR

PDSF-B Square flange (butt weld connection)

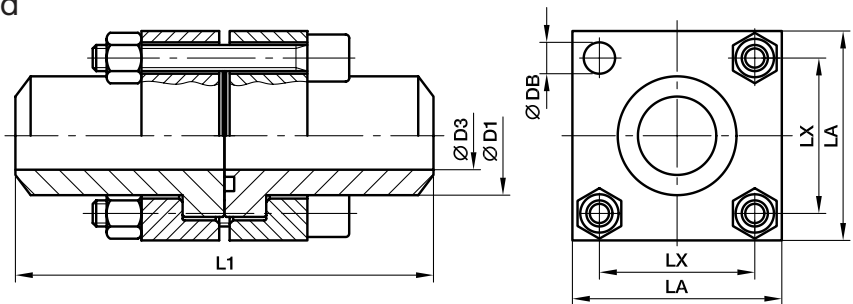
 Square flange / Butt weld tube end
(ISO 6164)

250 bar Series

Nom. flange size			D1	D3	L1	LA	LX	DB	Screws		Weight (steel) kg/piece	Order code*	PN (bar) ¹⁾
Series ²⁾	SAE (in)	ISO (DN)							(metr.)	O-ring			S
L	3/8	10	17.5	10	80	40	24.7	6.6	M 8 45	17.13 2.62	0.34	PDSF10/L/17.5B	250
L	1/2	13	21.6	13	100	45	29.7	9.0	M 8 50	18.64 3.53	0.44	PDSF13/L/21.6B	250
L	3/4	19	27.2	19	120	50	35.4	9.0	M 8 55	24.99 3.53	0.64	PDSF19/L/27.2B	250
L	1	25	34.5	25	140	65	43.8	11.0	M10 65	32.93 3.53	1.26	PDSF25/L/34.5B	250
L	1 1/4	32	43.0	31	160	75	51.6	13.5	M12 75	37.89 3.53	1.84	PDSF32/L/43B	250
L	1 1/2	38	48.6	38	180	90	60.1	17.5	M16 90	47.22 3.53	2.68	PDSF38/L/48.6B	250
L	2	51	61.0	50	200	100	69.3	17.5	M16 100	56.74 3.53	4.60	PDSF51/L/61B	250
L	2 1/2	56	76.6	63	220	120	83.4	22.0	M20 120	69.44 3.53	8.00	PDSF56/L/76.6B	250
L	3	63	89.0	70	240	140	102.5	22.0	M20 140	85.32 3.53	12.06	PDSF63/L/89B	250
L	4	80	114.0	90	280	160	113.5	22.0	M24 150	97.79 5.34	21.92	PDSF80/L/114B	250

400 bar Series

S	3/8	10	17.5	10	80	40	24.7	6.6	M 8 45	17.13 2.62	0.40	PDSF10/S/17.5B	400
S	1/2	13	21.6	13	100	45	29.7	9.0	M 8 50	18.64 3.53	0.62	PDSF13/S/21.6B	400
S	3/4	19	27.2	18	120	50	35.4	9.0	M 8 55	24.99 3.53	0.90	PDSF19/S/27.2B	400
S	1	25	34.5	22	140	65	43.8	11.0	M10 65	32.93 3.53	1.66	PDSF25/S/34.5B	400
S	1 1/4	32	43.0	28	160	75	51.6	13.5	M12 75	37.89 3.53	2.38	PDSF32/S/43B	400
S	1 1/2	38	48.6	32	180	90	60.1	17.5	M16 90	47.22 3.53	3.60	PDSF38/S/48.6B	400
S	2	51	61.0	41	200	100	69.3	17.5	M16 100	56.52 5.34	6.16	PDSF51/S/61B	400
S	2 1/2	56	76.6	50	220	120	83.4	22.0	M20 130	69.22 5.34	10.28	PDSF56/S/76.6B	400
S	3	63	89.0	58	240	150	102.5	26.0	M24 140	75.57 5.34	14.68	PDSF63/S/89B	400
S	3 1/2	70	102.0	63	260	160	113.1	26.0	M24 150	85.09 5.34	16.18	PDSF70/S/102B	400
S	4	80	114.0	74	280	180	123.7	33.0	M30 180	88.27 5.34	25.50	PDSF80/S/114B	350

1) Pressure shown = item deliverable

2) L = light series; S = heavy series

$$\frac{\text{PN (bar)}}{10} = \text{PN (MPa)}$$

The pressures given here are the maximum allowable for the flange fittings. If the pipe or tube used has a lower pressure rating, then the welded assembly rating will be the lower one, assuming the weld is adequately strong.

*Please add the suffixes below according to the material / surface required.

Order code suffixes			
Material	Suffix surface and material	Example Flange coupling incl. flange clamps, metr. screws and O-ring	Standard sealing material (no additional suffix needed)
Steel, blanc oil dipped	S	PDSF10/L/17.5BS	NBR

PCF-B Cetop square flange (weld connection)

Cetop flange / Butt weld end

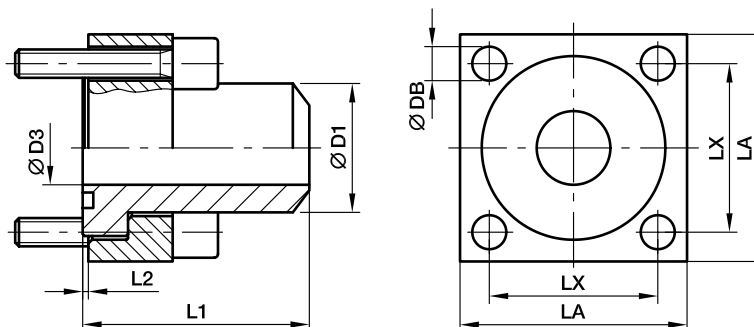

250 bar Series

Nom. flange size		D1	D3	L1	L2	LA	LX	DB	Screws		O-ring	Weight (steel) kg/piece	Order code*	PN (bar) ¹⁾
Series ²⁾	(in)								(metr.)					S
L	3/8	18	12.5	40	1.0	40	24.7	6.5	M 6 25	17.3 2.62	0.17	PCF38/L/18B	250	
L	1/2	22	14.0	45	1.0	45	29.7	8.5	M 8 30	18.64 3.53	0.22	PCF12/L/22B	250	
L	3/4	28	20.0	50	1.0	50	35.3	8.5	M 8 30	24.99 3.53	0.32	PCF34/L/28B	250	
L	1	35	25.0	55	1.0	65	43.8	10.5	M10 35	32.93 3.53	0.63	PCF1/L/35B	250	
L	1 1/4	43	31.0	61	1.0	75	51.6	13.0	M12 40	37.89 3.53	0.92	PCF114/L/43B	250	
L	1 1/2	50	38.0	65	1.0	85	60.0	15.0	M14 45	47.22 3.53	1.34	PCF112/L/50B	250	
L	2	62	47.0	70	1.5	100	69.4	17.0	M16 55	56.74 3.53	2.30	PCF2/L/62B	250	
L	2 1/2	76	58.0	75	1.5	120	83.4	21.0	M20 70	69.44 3.53	4.00	PCF212/L/76B	250	
L	3	90	70.0	85	1.5	140	102.5	21.0	M20 80	85.32 3.53	6.03	PCF3/L/90B	250	
L	3 1/2	102	80.0	90	1.5	140	102.5	21.0	M20 90	85.09 5.35	7.56	PCF312/L/102B	250	
L	4	114	90.0	105	1.5	160	113.2	25.0	M24 100	97.79 5.34	10.96	PCF4/L/114B	250	

400 bar Series

S	3/8	18	11.0	40	1.0	40	24.7	6.5	M 6 25	17.3 2.62	0.20	PCF38/S/18B	400
S	1/2	22	14.0	45	1.0	45	29.7	8.5	M 8 30	18.64 3.53	0.31	PCF12/S/22B	400
S	3/4	28	18.0	50	1.0	50	35.3	8.5	M 8 35	24.99 3.53	0.45	PCF34/S/28B	400
S	1	35	22.0	55	1.0	65	43.8	10.5	M10 40	32.93 3.53	0.83	PCF1/S/35B	400
S	1 1/4	44	29.0	61	1.0	75	51.6	13.0	M12 45	37.89 3.53	1.19	PCF114/S/44B	400
S	1 1/2	51	35.0	65	1.0	85	60.0	15.0	M14 55	47.22 3.53	1.80	PCF112/S/51B	400
S	2	61	43.0	70	1.5	100	69.4	17.0	M16 65	56.74 3.53	3.08	PCF2/S/61B	400
S	2 1/2	80	53.0	80	1.5	120	83.4	21.0	M20 70	69.22 5.34	5.14	PCF212/S/80B	400
S	3	90	58.0	90	1.5	140	102.5	21.0	M20 90	75.57 5.34	7.34	PCF3/S/90B	400
S	3 1/2	102	63.0	90	1.5	140	102.5	21.0	M20 90	85.09 5.34	8.09	PCF312/S/102B	400
S	4	114	74.0	105	1.5	160	113.2	25.0	M24 100	88.27 5.34	12.75	PCF4/S/114B	400

¹⁾ Pressure shown = item deliverable

²⁾ L = light series; S = heavy series

$$\frac{\text{PN (bar)}}{10} = \text{PN (MPa)}$$

The pressures given here are the maximum allowable for the flange fittings. If the pipe or tube used has a lower pressure rating, then the welded assembly rating will be the lower one, assuming the weld is adequately strong.

*Please add the suffixes below according to the material / surface required.

Order code suffixes			
Material	Suffix surface and material	Example incl. flange clamp, metr. screws and O-ring	Standard sealing material (no additional suffix needed)
Steel, blanc oil dipped	S	PCF38/L/18BS	NBR

PPCF Cetop square flange plug

Cetop square flange / Plug

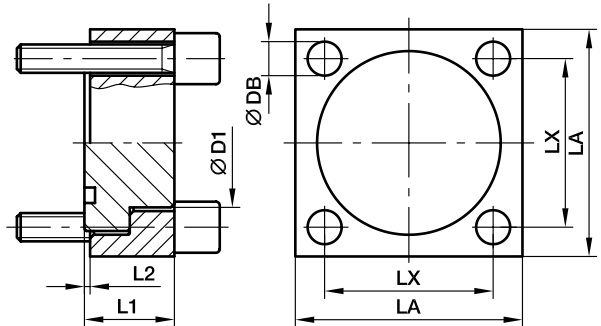

250 bar Series

Nom. flange size		D1	L1	L2	LA	LX	Screws (metr.)	O-ring	Weight (steel) kg/piece	Order code*	PN (bar) ¹⁾
Series ²⁾	(in)										S
L	3/8	18.0	15	1.0	40	24.7	M 6 25	17.3 2.62	0.09	PPCF38/L/18	250
L	1/2	24.0	16	1.0	45	29.7	M 8 30	18.64 3.53	0.11	PPCF12/L/24	250
L	3/4	31.5	17	1.0	50	35.3	M 8 30	24.99 3.53	0.16	PPCF34/L/31.5	250
L	1	38.0	19	1.0	65	43.8	M10 35	32.93 3.53	0.32	PPCF1/L/38	250
L	1 1/4	43.0	23	1.0	75	51.6	M12 40	37.89 3.53	0.46	PPCF114/L/43	250
L	1 1/2	50.0	26	1.0	85	60.0	M14 45	47.22 3.53	0.67	PPCF112/L/50	250
L	2	62.0	31	1.5	100	69.4	M16 55	56.74 3.53	1.15	PPCF2/L/62	250
L	2 1/2	76.0	37	1.5	120	83.4	M20 70	69.44 3.53	2.00	PPCF212/L/76	250
L	3	90.0	42	1.5	140	102.5	M20 80	85.32 3.53	3.02	PPCF3/L/90	250
L	3 1/2	102.0	54	1.5	140	102.5	M20 90	85.09 5.35	3.78	PPCF312/L/102	250
L	4	114.0	62	1.5	160	113.2	M24 100	97.79 5.34	5.48	PPCF4/L/114	250
L	5	141.0	62	1.5	180	132.0	M27 100	120.7 5.34	6.48	PPCF5/L/141	250

400 bar Series

S	3/8	18.0	17	1.0	40	24.7	M 6 25	17.3 2.62	0.10	PPCF38/S/18	400
S	1/2	24.0	19	1.0	45	29.7	M 8 30	18.64 3.53	0.16	PPCF12/S/24	400
S	3/4	32.0	21	1.0	50	35.3	M 8 35	24.99 3.53	0.23	PPCF34/S/32	400
S	1	38.0	25	1.0	65	43.8	M10 40	32.93 3.53	0.42	PPCF1/S/38	400
S	1 1/4	44.0	31	1.0	75	51.6	M12 50	37.89 3.53	0.60	PPCF114/S/44	400
S	1 1/2	51.0	33	1.0	85	60.0	M14 55	47.22 3.53	0.90	PPCF112/S/51	400
S	2	67.0	42	1.5	100	69.4	M16 65	56.74 3.53	1.54	PPCF2/S/67	400
S	2 1/2	80.0	48	1.5	120	83.4	M20 70	69.22 5.34	2.57	PPCF212/S/80	400
S	3	90.0	54	1.5	140	102.5	M20 90	75.57 5.34	3.67	PPCF3/S/90	400
S	3 1/2	102.0	54	1.5	140	102.5	M20 90	85.09 5.34	4.05	PPCF312/S/102	400
S	4	114.0	62	1.5	160	113.2	M24 100	88.27 5.34	6.38	PPCF4/S/114	400

¹⁾ Pressure shown = item deliverable

²⁾ L = light series; S = heavy series

$$\frac{PN \text{ (bar)}}{10} = PN \text{ (MPa)}$$

*Please add the suffixes below according to the material / surface required.

Order code suffixes			
Material	Suffix surface and material	Example flange plug incl. flange clamp, metr. screws and O-ring	Standard sealing material (no additional suffix needed)
Steel, blanc oil dipped	S	PPCF38/L/18S	NBR



PDCF-B Cetop square flange coupling

Cetop square flange / Butt weld end

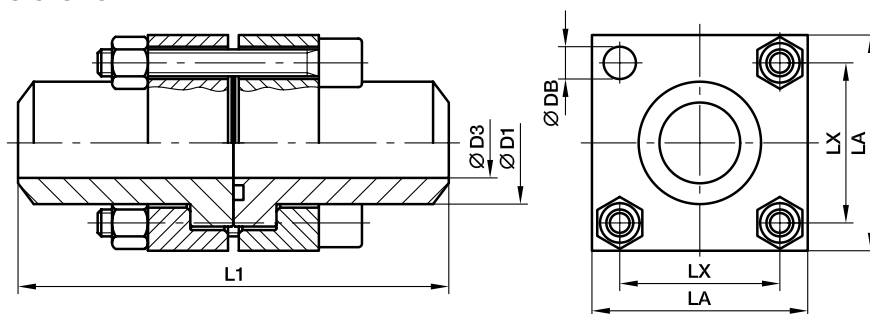

250 bar Series

Nom. flange size		D1	D3	L1	LA	LX	Screws		Weight (steel) kg/piece	Order code*	PN (bar) ¹⁾
Series ²⁾	(in)						(metr.)	O-ring			S
L	3/8	18	12.5	80	40	24.7	M 6 35	17.3 2.62	0.43	PDCF38/L/18B	250
L	1/2	22	14.0	90	45	29.7	M 8 40	18.64 3.53	0.55	PDCF12/L/22B	250
L	3/4	28	20.0	100	50	35.3	M 8 45	24.99 3.53	0.80	PDCF34/L/28B	250
L	1	35	25.0	110	65	43.8	M10 50	32.93 3.53	1.58	PDCF1/L/35B	250
L	1 1/4	43	31.0	120	75	51.6	M12 60	37.89 3.53	2.30	PDCF114/L/43B	250
L	1 1/2	50	38.0	130	85	60.0	M14 70	47.22 3.53	3.35	PDCF112/L/50B	250
L	2	62	47.0	140	100	69.4	M16 80	56.74 3.53	5.75	PDCF2/L/62B	250
L	2 1/2	76	58.0	150	120	83.4	M20 100	69.44 3.53	10.0	PDCF212/L/76B	250
L	3	90	70.0	170	140	102.5	M20 110	85.32 3.53	15.08	PDCF3/L/90B	250
L	3 1/2	102	80.0	180	140	102.5	M20 130	85.09 5.35	18.90	PDCF312/L/102B	250
L	4	114	90.0	210	160	113.2	M24 150	97.79 5.34	27.40	PDCF4/L/114B	250

400 bar Series

S	3/8	18	11.0	80	40	24.7	M 6 40	17.3 2.62	0.50	PDCF38/S/18B	400
S	1/2	22	14.0	90	45	29.7	M 8 45	18.64 3.53	0.78	PDCF12/S/22B	400
S	3/4	28	18.0	100	50	35.3	M8 50	24.99 3.53	1.13	PDCF34/S/28B	400
S	1	35	22.0	110	65	43.8	M10 60	32.93 3.53	2.08	PDCF1/S/35B	400
S	1 1/4	44	29.0	120	75	51.6	M12 70	37.89 3.53	2.98	PDCF114/S/44B	400
S	1 1/2	51	35.0	130	85	60.0	M14 80	47.22 3.53	4.50	PDCF112/S/51B	400
S	2	61	43.0	140	100	69.4	M16 100	56.74 3.53	7.70	PDCF2/S/61B	400
S	2 1/2	80	53.0	160	120	83.4	M20 120	69.22 5.34	12.85	PDCF212/S/80B	400
S	3	90	58.0	180	140	102.5	M20 130	75.57 5.34	18.35	PDCF3/S/90B	400
S	3 1/2	102	63.0	180	140	102.5	M20 130	85.09 5.34	20.23	PDCF312/S/102B	400
S	4	114	74.0	210	160	113.2	M24 150	88.27 5.34	31.88	PDCF4/S/114B	400

¹⁾ Pressure shown = item deliverable

²⁾ L = light series; S = heavy series

$$\frac{\text{PN (bar)}}{10} = \text{PN (MPa)}$$

The pressures given here are the maximum allowable for the flange fittings. If the pipe or tube used has a lower pressure rating, then the welded assembly rating will be the lower one, assuming the weld is adequately strong.

*Please add the suffixes below according to the material / surface required.

Order code suffixes			
Material	Suffix surface and material	Example Flange coupling incl. flange clamps, metr. screws and O-ring	Standard sealing material (no additional suffix needed)
Steel, blanc oil dipped	S	PDCF38/L/18BS	NBR

PLCF-B Cetop square flange 90° elbow connection

Cetop square flange 90° elbow / Butt weld end

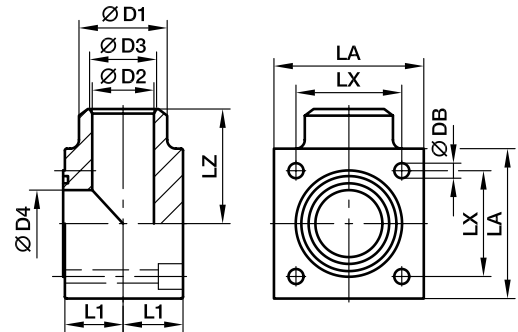

250 bar Series

Nom. flange size		D1	D2	D3	D4	L1	LA	LX	LZ	DB	Screws (metr.)	O-ring	Weight (steel) kg/piece	Order code*	PN (bar) ¹⁾ S
Series ²⁾	(in)														
L	3/8	18	12	12	12.5	12	40	24.7	32	6.5	M 6 30	17.3 2.62	0.44	PLCF38/L/18B	250
L	1/2	22	14	14	15.0	17	45	29.7	40	8.5	M 8 40	18.64 3.53	0.57	PLCF12/L/22B	250
L	3/4	28	19	19	20.0	19	50	35.3	42	8.5	M 8 45	24.99 3.53	0.83	PLCF34/L/28B	250
L	1	35	23	23	25.0	24	65	43.8	50	10.5	M10 55	32.93 3.53	1.64	PLCF1/L/35B	250
L	1 1/4	44	30	30	32.0	30	75	51.6	56	13.0	M12 70	37.89 3.53	2.39	PLCF114/L/44B	250
L	1 1/2	50	35	38	38.0	34	85	60.0	65	15.0	M14 80	47.22 3.53	3.48	PLCF112/L/50B	250
L	2	63	43	47	47.0	42	100	69.4	75	17.0	M16 100	56.74 3.53	5.98	PLCF2/L/63B	250
L	2 1/2	86	53	58	58.0	53	120	83.4	85	21.0	M20 120	69.44 3.53	10.40	PLCF212/L/86B	250
L	3	90	65	70	70.0	59	140	102.5	100	21.0	M20 140	85.32 3.53	15.68	PLCF3/L/90B	250
L	4	114	80	90	90.0	65	160	113.2	110	25.0	M24 140	97.79 5.34	19.66	PLCF4/L/114B	250

400 bar Series

S	3/8	18	12	12	12.5	12	40	24.7	32	6.5	M 6 30	17.3 2.62	0.52	PLCF38/S/18B	400
S	1/2	22	14	14	15.0	17	45	29.7	40	8.5	M 8 40	18.64 3.53	0.81	PLCF12/S/22B	400
S	3/4	28	19	19	20.0	19	50	35.3	42	8.5	M 8 45	24.99 3.53	1.17	PLCF34/S/28B	400
S	1	35	23	23	25.0	24	65	43.8	50	10.5	M10 55	32.93 3.53	2.16	PLCF1/S/35B	400
S	1 1/4	44	30	30	32.0	30	75	51.6	56	13.0	M12 70	37.89 3.53	3.09	PLCF114/S/44B	400
S	1 1/2	51	32	35	38.0	34	85	60.0	65	15.0	M14 80	47.22 3.53	4.68	PLCF112/S/51B	400
S	2	63	38	43	47.0	42	100	69.4	75	17.0	M16 100	56.74 3.53	8.01	PLCF2/S/63B	400
S	2 1/2	80	48	53	58.0	53	120	83.4	85	21.0	M20 120	69.22 5.34	13.36	PLCF212/S/80B	400
S	3	90	58	58	58.0	59	140	102.5	100	21.0	M20 140	75.57 5.34	19.08	PLCF3/S/90B	400

¹⁾ Pressure shown = item deliverable

²⁾ L = light series; S = heavy series

$$\frac{\text{PN (bar)}}{10} = \text{PN (MPa)}$$

The pressures given here are the maximum allowable for the flange fittings. If the pipe or tube used has a lower pressure rating, then the welded assembly rating will be the lower one, assuming the weld is adequately strong.

*Please add the suffixes below according to the material / surface required.

Order code suffixes			
Material	Suffix surface and material	Example incl. metr. screws and O-ring	Standard sealing material (no additional suffix needed)
Steel, blanc oil dipped	S	PLCF38/L/18BSM	NBR

PTCF-B Cetop square flange 180° T-connection

Cetop square flange 180° T-connection / Butt weld end

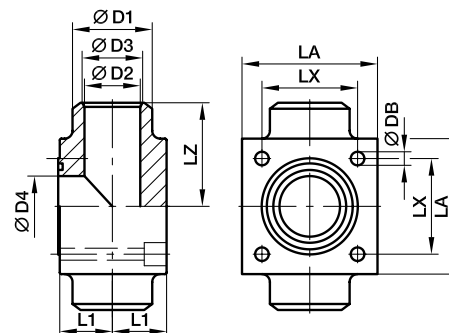

250 bar Series

Nom. flange size		D1	D2	D3	D4	L1	LA	LX	LZ	DB	Screws (metr.)	O-ring	Weight (steel) kg/piece	Order code*	PN (bar) ¹⁾ S
Series ²⁾	(in)														
L	3/8	18	12	12	12.5	12	40	24.7	32	6.5	M 6 30	17.3 2.62	0.75	PTCF38/L/18B	250
L	1/2	22	14	14	15.0	17	45	29.7	40	8.5	M 8 40	18.64 3.53	0.97	PTCF12/L/22B	250
L	3/4	28	19	19	20.0	19	50	35.3	42	8.5	M 8 45	24.99 3.53	1.41	PTCF34/L/28B	250
L	1	35	23	23	25.0	24	65	43.8	50	10.5	M10 55	32.93 3.53	2.78	PTCF1/L/35B	250
L	1 1/4	44	30	30	32.0	30	75	51.6	56	13.0	M12 70	37.89 3.53	4.07	PTCF114/L/44B	250
L	1 1/2	50	35	38	38.0	34	85	60.0	65	15.0	M14 80	47.22 3.53	5.92	PTCF112/L/50B	250
L	2	63	43	47	47.0	42	100	69.4	75	17.0	M16 100	56.74 3.53	10.17	PTCF2/L/63B	250
L	2 1/2	76	53	58	58.0	53	120	83.4	85	21.0	M20 120	69.44 3.53	17.68	PTCF212/L/76B	250
L	3	90	65	70	70.0	59	140	102.5	100	21.0	M20 140	85.32 3.53	26.65	PTCF3/L/90B	250
L	4	114	80	90	90.0	65	160	113.2	110	25.0	M24 140	97.79 5.34	33.42	PTCF4/L/114B	250

400 bar Series

S	3/8	18	12	12	12.5	12	40	24.7	32	6.5	M 6 30	17.3 2.62	0.88	PTCF38/S/18B	400
S	1/2	22	14	14	15.0	17	45	29.7	40	8.5	M 8 40	18.64 3.53	1.37	PTCF12/S/22B	400
S	3/4	28	19	19	20.0	19	50	35.3	42	8.5	M 8 45	24.99 3.53	1.99	PTCF34/S/28B	400
S	1	35	23	23	25.0	24	65	43.8	50	10.5	M10 55	32.93 3.53	3.67	PTCF1/S/35B	400
S	1 1/4	44	30	30	32.0	30	75	51.6	56	13.0	M12 70	37.89 3.53	5.26	PTCF114/S/44B	400
S	1 1/2	51	32	35	38.0	34	85	60.0	65	15.0	M14 80	47.22 3.53	7.96	PTCF112/S/51B	400
S	2	63	38	43	47.0	42	100	69.4	75	17.0	M16 100	56.74 3.53	13.61	PTCF2/S/63B	400
S	2 1/2	80	48	53	58.0	53	120	83.4	85	21.0	M20 120	69.22 5.34	22.72	PTCF212/S/80B	400
S	3	90	58	58	58.0	59	140	102.5	100	21.0	M20 140	75.57 5.34	32.44	PTCF3/S/90B	400

¹⁾ Pressure shown = item deliverable

²⁾ L = light series; S = heavy series

$$\frac{\text{PN (bar)}}{10} = \text{PN (MPa)}$$

The pressures given here are the maximum allowable for the flange fittings. If the pipe or tube used has a lower pressure rating, then the welded assembly rating will be the lower one, assuming the weld is adequately strong.

*Please add the suffixes below according to the material / surface required.

Order code suffixes			
Material	Suffix surface and material	Example incl. metr. screws and O-ring	Standard sealing material (no additional suffix needed)
Steel, blanc oil dipped	S	PTCF38/L/18BSM	NBR

KH-B1V-S Ball valve with SAE Flange connection (6000 PSI)

SAE Flange (ISO 6162-1/-2) / Ball valve 2/2 way steel

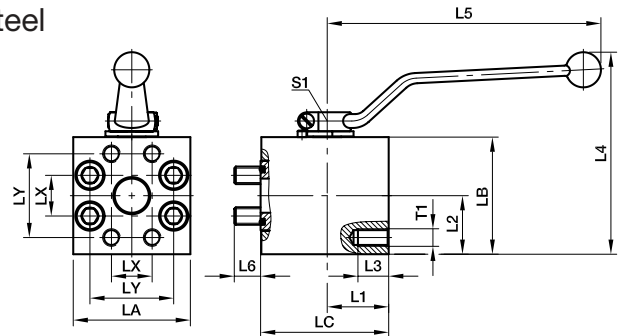

6000 PSI Series

Nom. flange size																Screws		O-ring		Weight (steel)		Order code*		PN (bar) ¹⁾
SAE (in)	ISO (DN)	L1	L2	L3	L4	L5	L6	LX	LY	LA	LB	LC	S1	T1	(metr.)		kg/piece		S					
1/2	12	32.0	28.5	19	107	112	13.5	18.2	40.5	60	55	60.5	10	M 8	M 8	65	18.66	3.53	1.29	KH12B1V62	420			
3/4	20	31.0	35.0	16	134	187	14.0	23.8	50.8	70	70	62.5	14	M10	M10	65	25.00	3.53	2.15	KH20B1V63	420			
1	25	39.0	40.0	21	144	187	18.0	27.8	57.2	80	80	75.5	14	M12	M12	80	32.92	3.53	2.95	KH25B1V64	420			
1 1/4	32	43.5	50.0	23	129	320	18.0	31.8	66.7	100	100	82.0	17	M14	M14	85	37.70	3.53	6.21	KH32B1V65	420			
1 1/2	40	53.5	60.0	26	149	320	18.0	36.5	79.4	120	120	99.0	17	M16	M16	100	47.22	3.53	9.50	KH40B1V36	420			
2	50	61.0	61.5	34	153	320	22.0	44.5	96.8	134	124	109.5	17	M20	M20	100	56.74	3.53	12.80	KH50B1V38	420			

¹⁾ Pressure shown = Item deliverable

The pressure specification PN for quarter turn ball valves applies to the design factor 1.5 (according DIN 3230 T5 and ISO 5208).

$$\frac{PN \text{ (bar)}}{10} = PN \text{ (MPa)}$$

Materials:

Body made of steel, coating DIN 50938-FE/A/T4,
ball of hard chrome plated carbon steel, stem of zinc plated steel.

Seals:

Ball seat of POM (e.g. Delrin), stem seal of NBR (e.g. Perbunan).

Applications:

Suitable for petroleum-based hydraulic fluid, lubricants and fuel oil.
For air applications suitable up to 100 bar.

Temperature range:

-10 up to +100° C

*Please add the suffixes below according to the material / surface required.

Order code suffixes				
Material	Suffix surface and material	Example only ball valve flange	Example ball valve flange incl. metr. screws and O-ring	Standard sealing material (no additional suffix needed)
Steel, blanc oil dipped	S	KH12B1V62S	KH12B1V62SM	NBR

KH-B2V-S Ball valve with SAE Flange connection (block 3000/6000 PSI)

SAE Flange / Ball valve 2/2 way steel
(ISO 6162-1/-2)

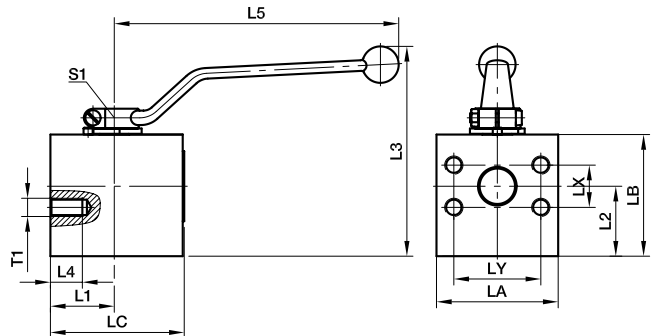

3000 PSI Series

Nom. flange size		T1															Weight (steel) kg/piece	Order code*	PN (bar) ¹⁾ S
SAE (in)	ISO (DN)	(metr.)	(in)	L1	L2	L3	L4	L5	LX	LY	LA	LB	LC	S1					
1/2	12	M 8	5/16-18UNC	23.5	22	97	17	112	17.5	38.1	55	45	60	10	1.1	KH12B2V32	210		
3/4	20	M10	3/8-16UNC	39.5	39	128	21	187	22.2	47.6	70	70	80	14	2.8	KH20B2V33	210		
1	25	M10	3/8-16UNC	42.0	46	138	19	187	26.2	52.4	80	80	88	14	4.0	KH25B2V34	210		

6000 PSI Series

1/2	12	M 8	5/16-18UNC	23.5	22	97	17	112	18.2	40.5	55	45	60	10	1.1	KH12B2V62	420
3/4	20	M10	3/8-16UNC	39.5	39	128	21	187	23.8	50.8	70	70	80	14	2.8	KH20B2V63	420
1	25	M10	7/16-16UNC	42.0	46	138	19	187	27.8	57.2	80	80	88	14	4.0	KH25B2V64	420

¹⁾ Pressure shown = Item deliverable

The pressure specification PN for quarter turn ball valves applies to the design factor 1.5 (according DIN 3230 T5 and ISO 5208).

$$\frac{\text{PN (bar)}}{10} = \text{PN (MPa)}$$

Materials:

Body made of steel, coating DIN 50938-FE/A/T4,
ball of hard chrome plated carbon steel, stem of zinc plated steel.

Applications:

Suitable for petroleum-based hydraulic fluid, lubricants and fuel oil.
For air applications suitable up to 100 bar.

Seals:

Ball seat of POM (e.g. Delrin), stem seal of NBR (e.g. Perbunan).

Temperature range:

-10 up to +100° C

*Please add the suffixes below according to the material / surface required.

Order code suffixes				
Material	Suffix surface and material	Example only ball valve flange with metr. threads	Example only ball valve flange with UNC threads	Standard sealing material (no additional suffix needed)
Steel, blanc oil dipped	S	KH12B2V32SM	KH12B2V32SU	NBR

KH-B3V-S Ball valve with SAE Flange connection

SAE Flange / Ball valve 2/2 way steel
(ISO 6162-1/-2)

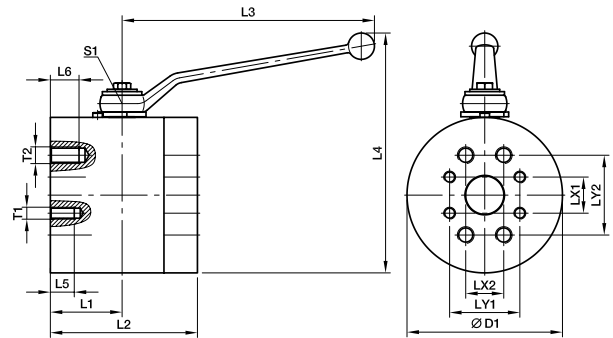

3000 PSI Series / 6000 PSI Series

Nom. flange size									3000 PSI Connection					6000 PSI Connection					Weight (steel) kg/piece	Order code*	PN (bar) ¹⁾	
SAE (in)	ISO (DN)	D1	L1	L2	L3	L4	S1	T1	UNC	LX1	LY1	L5	PN	T2	UNC	LX2	LY2	L6				PN
1 1/4	32	130	60	123	320	158.5	17	M12	7/16-14	30.2	58.7	27	276	M14	1/2-13	31.8	66.7	24	420	11.3	KH32B3V35	420
1 1/2	40	140	61	126	320	168.5	17	M12	1/2-13	35.7	69.9	25	207	M16	5/8-11	36.5	79.4	26	420	13.1	KH40B3V36	420
2	50	160	79	158	320	178.5	17	M12	1/2-13	42.8	77.8	25	207	M20	3/4-10	44.4	96.8	34	420	21.2	KH50B3V38	420

¹⁾ Pressure shown = Item deliverable

The pressure specification PN for quarter turn ball valves applies to the design factor 1.5 (according DIN 3230 T5 and ISO 5208).

$$\frac{PN \text{ (bar)}}{10} = PN \text{ (MPa)}$$

Materials:

Body made of steel, coating DIN 50938-FE/A/T4,
ball of hard chrome plated carbon steel, stem of zinc plated steel.

Applications:

Suitable for petroleum-based hydraulic fluid, lubricants and fuel oil.
For air applications suitable up to 100 bar.

Seals:

Ball seat of POM (e.g. Delrin), stem seal of NBR (e.g. Perbunan).

Temperature range:

-10 up to +100° C

*Please add the suffixes below according to the material / surface required.

Order code suffixes				
Material	Suffix surface and material	Example only ball valve flange with metr. threads	Example only ball valve flange with UNC threads	Standard sealing material (no additional suffix needed)
Steel, blanc oil dipped	S	KH32B3V35SM	KH32B3V35SU	NBR

KH-A-S Ball valve with SAE Flange adapter connection

SAE Flange / Ball valve 2/2 way steel
(ISO 6162-1/-2)

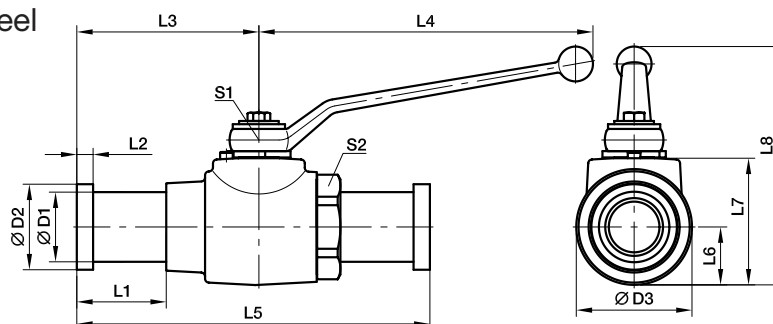

3000 PSI Series

Nom. flange size																Weight (steel) kg/piece		Order code*		PN (bar) ¹⁾
SAE (in)	ISO (DN)	D1	D2	D3	L1	L2	L3	L4	L5	L6	L7	L8	S1	S2	O-ring			S		
1/2	12	24	30.2	35	42.0	6.7	75.5	112	151.0	17.0	40	92	10	32	18.66	3.53	0.9	KH12A32	350	
3/4	20	32	38.1	45	43.0	6.7	81.0	187	162.0	24.0	55	113	14	41	25.00	3.53	1.7	KH20A33	315	
1	25	38	44.4	55	38.9	8.0	89.0	187	178.0	26.0	60	118	14	50	32.92	3.53	2.5	KH25A34	315	
1 1/4	32	43	50.8	73	40.3	8.0	99.0	227	190.5	36.5	80	155	17	60	37.70	3.53	3.1	KH32A35	276	
1 1/2	40	50	60.3	85	58.3	8.0	115.5	227	231.0	42.5	90	165	17	70	47.22	3.53	4.3	KH40A36	207	
2	50	62	71.4	99	50.9	9.5	116.0	227	232.0	49.5	104	179	17	85	56.74	3.53	5.8	KH50A38	207	

6000 PSI Series

1/2	12	24	31.7	35	42.0	7.7	75.5	112	151.0	17.0	40	92	10	32	18.66	3.53	1.0	KH12A62	420
3/4	20	32	41.3	45	49.0	8.8	87.0	187	174.0	24.0	55	113	14	46	25.00	3.53	1.9	KH20A63	315
1	25	38	47.6	55	49.0	9.5	99.0	187	198.0	26.0	60	118	14	50	32.92	3.53	2.8	KH25A64	315
1 1/4	32	44	54.0	73	56.5	10.3	115.0	227	223.0	36.5	80	155	17	60	37.70	3.53	3.3	KH32A65	315
1 1/2	40	51	63.5	85	83.5	12.6	14.5	227	281.0	42.5	90	165	17	70	47.22	3.53	4.8	KH40A66	315
2	50	67	79.4	99	93.0	12.6	158.0	227	316.0	49.5	104	179	17	85	56.74	3.53	7.4	KH50A68	315

¹⁾ Pressure shown = Item deliverable

The pressure specification PN for quarter turn ball valves applies to the design factor 1.5 (according DIN 3230 T5 and ISO 5208).

$$\frac{PN \text{ (bar)}}{10} = PN \text{ (MPa)}$$

Materials:

Body made of steel, coating DIN 50938-FE/A/T4, ball of hard chrome plated carbon steel, stem of zinc plated steel.

Applications:

Suitable for petroleum-based hydraulic fluid, lubricants and fuel oil. For air applications suitable up to 100 bar.

Seals:

Ball seat of POM (e.g. Delrin), stem seal of NBR (e.g. Perbunan).

Temperature range:

-10 up to +100° C











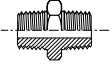
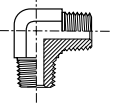
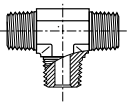
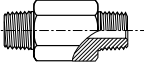

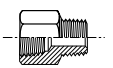
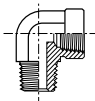
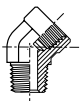
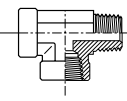
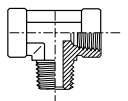

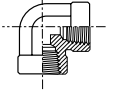

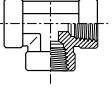
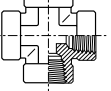

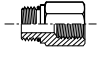
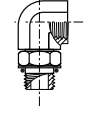
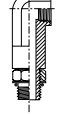

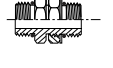

*Please add the suffixes below according to the material / surface required.

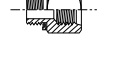
Order code suffixes			
Material	Suffix surface and material	Example only ball valve flange adapter	Description
Steel, blanc oil dipped	S	KH12A32S	only ball valve flange adapter



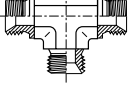
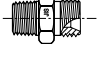
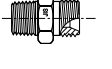

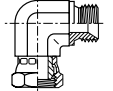
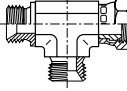
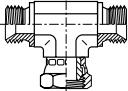

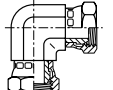
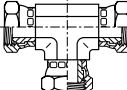











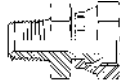
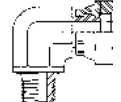

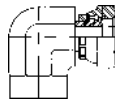
Adapters

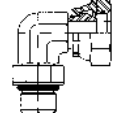
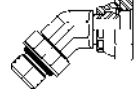
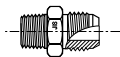
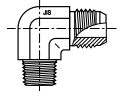
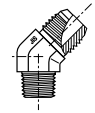
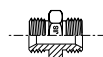
Visual index

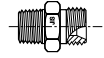
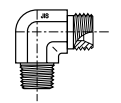
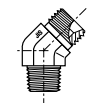
NPTF Adapters Male/male						
	FFM / p. N4	CRM / p. N5	RRS / p. N5	FFFM / p. N6		
NPTF Adapters Male/Female						
	PTRM / p. N7	FGM / p. N8	CDM / p. N9	CD45M / p. N10	MRO / p. N11	MMS / p. N12
NPTF Adapters Female/Female						
	GGM / p. N13	DDM / p. N14	DD45 / p. N14	MMOM / p. N15	KMMOO / p. N15	
NPTF Plug			UNF/NPTF Adapters			
	HPM / p. N16	HHP / p. N16		F5OG / p. N17	AOEG / p. N18	AOE4G / p. N18
UNF Adapters			UNF Plugs			
	F5OG5 / p. N19	F5OHAO / p. N20		G5G5JG5 / p. N20	P5ONM / p. N21	HP5ON / p. N22
BSPT-BSPP metric-UNF Conversion adapters						
	F3HMG5 / p. N23	F4OHMG5 / p. N24	F8OHMG5 / p. N25			
Male/Male adapters BSPP 60° cone, BSPT, NPT						
	HMK4 / p. N26	WMK4WL4NM / p. N27	EMK4 / p. N28	JMK4 / p. N28	F3MK4 / p. N38	FMK4 / p. N40
Male/Female swivel adapters BSPP 60° cone						
	F6MK4 / p. N30	C6MK4 / p. N31	R6MK4 / p. N32	S6MK4 / p. N33		
Female/Female swivel adapters BSPP 60° cone						
	H6MK4 / p. N34	E6MK4 / p. N35	J6MK4 / p. N36			

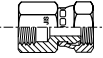
Visual index

<p>BSPP 60° cone Expander/Adapter cap</p>	 G4MK4 / p. N37	 FNMK4 / p. N39	 PNMK4 / p. N29			
<p>BSPP Adapters Female/Female</p>	 GG44M / p. N41	 MMO444M / p. N42				
<p>Reducing bushes BSPP/BSPT</p>	 PTR44M / p. N43	 PTR34M / p. N44	<p>BSPT male union and plug</p>	 FF33M / p. N45	 HP3M - p. N46	
<p>Female swivel NPSM / male NPTF</p>	 0107 / p. N47	 2107 / p. N48	 3107 / p. N49			
<p>Female swivel NPSM / female NPTF</p>	 0207 / p. N50	 2207 / p. N51				
<p>Female swivel NPSM / male UNF</p>	 0507 / p. N52	 2507 / p. N53	 3507 / p. N54			
<p>JIS Adapters Male to BSPT</p>	 F3MT4 / p. N55	 C3T4 / p. N56	 V3T4 / p. N56	<p>JIS Unions</p>	 HMP4 / p. N57	 HP46 / p. N57
<p>JIS Adapters Female cone to BSPT</p>	 F3MP4 / p. N58	 C3P4 / p. N58	 V3P4 / p. N59	 F63MP4 / p. N59	 G63P4 / p. N60	 G3P4 / p. N60
<p>Seals/ Retaining ring</p>	 Adapter Components / p. N61					



Adapters

FFM Male nipple

Male NPTF* thread (SAE J476) / Male NPTF* thread (SAE J476)
SAE 140137

*Stainless Steel = NPT to prevent galling

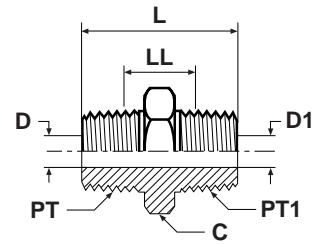

Thread NPT/NPTF PT	Thread NPT/NPTF PT1	C mm	D mm	D1 mm	L mm	LL mm	Weight (steel) g/1 piece	Adapter Steel	Adapter Stainless Steel	PN (bar)
1/8-27	1/8-27	11	5	5	27	15	11	1/8FFMS	1/8FFMSS	420
1/4-18	1/8-27	16	7	5	32	17	31	1/4 X 1/8 FF-S	1/4X1/8FFMSS	420
1/4-18	1/4-18	16	7	7	37	20	28	1/4FFMS	1/4FFMSS	420
3/8-18	1/8-27	19	10	5	37	22	45	3/8 X 1/8 FF-S	3/8X1/8FFMSS	420
3/8-18	1/4-18	19	10	10	37	19	51	3/8X1/4FFMS	3/8X1/4FFMSS	420
3/8-18	3/8-18	19	10	10	37	19	40	3/8FFMS	3/8FFMSS	420
1/2-14	1/8-27	22	14	5	39	21	58	1/2 X 1/8 FF-S	1/2X1/8FFMSS	420
1/2-14	1/4-18	22	7	7	43	23	88	1/2X1/4FFMS	1/2X1/4FFMSS	420
1/2-14	3/8-18	22	10	10	43	23	71	1/2X3/8FFMS	1/2X3/8FFMSS	420
1/2-14	1/2-14	22	14	14	48	24	71	1/2FFMS	1/2FFMSS	420
3/4-14	1/4-18	29	18	7	45	24	104	3/4 X 1/4 FF-S	3/4X1/4FFMSS	380
3/4-14	3/8-18	29	19	11	45	24	134	3/4 X 3/8 FF-S	3/4X3/8FFMSS	380
3/4-14	1/2-14	29	18	7	50	21	161	3/4 X 1/2 FF-S	3/4X1/2FFMSS	380
3/4-14	3/4-14	27	18	18	50	18	104	3/4FFMS	3/4FFMSS	380
1-11 1/2	1-11 1/2	36	24	24	59	30	179	1FFMS	1FFMSS	380
1-11 1/2	1/4-18	35	24	7	50	27	188	1 X 1/4 FF-S	1X1/4FFMSS	380
1-11 1/2	3/4-14	35	18	18	53	26	195	1 X 3/4 FF-S	1X3/4FFMSS	380
1 1/4-11 12	1-11 1/2	45	32	24	62	33	256	1 1/4 X 1 FF-S	11/4X1FFMSS	350
1 1/4-11 1/2	1 1/4-11 1/2	45	32	32	63	33	256	1 1/4 FF-S	11/4FFMSS	350
1 1/2-11 1/2	1 1/2-11 1/2	51	38	38	66	36	364	1 1/2 FF-S	11/2FFMSS	210
2-11 1/2	2-11 1/2	64	49	49	72	41	848	2 FF-S	2FFMSS	170

Order codes shown are part of our current manufacturing programme.
Imperial and metric parts may vary in hexagon dimensions.

$$\frac{\text{PN (bar)}}{10} = \text{PN (MPa)}$$

Pressure ratings – PN shown, apply to Steel and Stainless Steel versions of the product.

CRM Male thread elbow

Male NPTF* thread (SAE J476) / Male NPTF* thread (SAE J476)

SAE 140237

*Stainless Steel = NPT to prevent galling

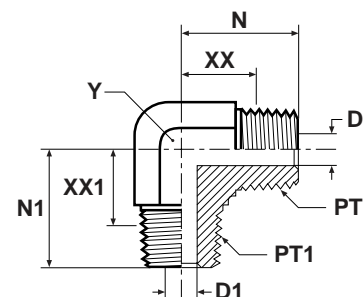

Thread NPT/NPTF PT	Thread NPT/NPTF PT1	D mm	D1 mm	N mm	N1 mm	XX mm	XX1 mm	Y mm	Weight (steel) g/1 piece	Adapter Steel	Adapter Stainless Steel	PN (bar)
1/8-27	1/8-27	5	5	20	20	14	14	11	27	1/8 CR-S	1/8 CR-SS	420
1/4-18	1/4-18	7	7	28	28	19	19	14	54	1/4 CRMS	1/4 CR-SS	420
3/8-18	3/8-18	10	10	31	31	22	22	19	181	3/8 CR-S	3/8 CR-SS	420
3/8-18	1/4-18	10	7	31	31	22	22	19	66	3/8 X 1/4 CR-S	3/8 X 1/4 CR-SS	420
1/2-14	1/2-14	14	14	37	37	26	26	22	172	1/2 CR-S	1/2 CR-SS	420
1/2-14	3/8-18	14	10	37	33	26	21	22	103	1/2 X 3/8 CR-S	1/2 X 3/8 CR-SS	420
3/4-14	3/4-14	18	18	40	40	28	28	27	263	3/4 CR-S	3/4 CR-SS	280
3/4-14	1/2-14	18	14	40	37	28	25	27	164	3/4 X 1/2 CR-S	3/4 X 1/2 CR-SS	280
1-11 1/2	1-11 1/2	24	24	50	50	36	36	41	462	1 CR-S	1 CR-SS	210
1 1/4-11 1/2	1 1/4-11 1/2	32	32	56	56	41	41	48	782	1 1/4 CR-S	1 1/4 CR-SS	170
1 1/2-11 1/2	1 1/2-11 1/2	38	38	59	59	56	45	48	782	1 1/2 CR-S	1 1/2 CR-SS	170

RRS Male thread tee

Male NPTF* thread (SAE J476)

SAE 140437

*Stainless Steel = NPT to prevent galling

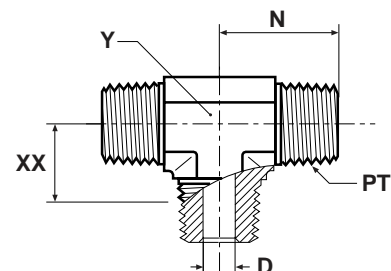

Thread NPT/NPTF PT	D mm	N mm	XX mm	Y mm	Weight (steel) g/1 piece	Adapter Steel	Adapter Stainless Steel	PN (bar)
1/8-27	5	20	14	11	33	1/8 RRS-S	1/8 RRS-SS	420
1/4-18	7	28	19	14	56	1/4 RRS-S	1/4 RRS-SS	420
3/8-18	10	31	22	19	92	3/8 RRS-S	3/8 RRS-SS	420
1/2-14	14	37	26	22	96	1/2 RRS-S	1/2 RRS-SS	420
3/4-14	19	40	28	27	235	3/4 RRS-S	3/4 RRS-SS	280

Order codes shown are part of our current manufacturing programme.
Imperial and metric parts may vary in hexagon dimensions.

$$\frac{\text{PN (bar)}}{10} = \text{PN (MPa)}$$

Pressure ratings – PN shown, apply to Steel and Stainless Steel versions of the product.

Adapters

FFFM Extended male nipple

Male NPTF* thread (SAE J476) / Male NPTF* thread (SAE J476)

*Stainless Steel = NPT to prevent galling

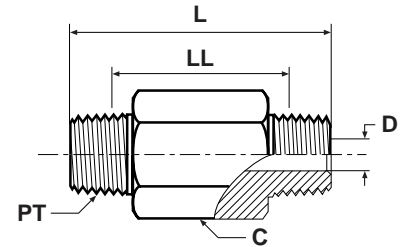

Thread NPT/NPTF PT	C mm	D mm	L mm	LL mm	Weight (steel) g/1 piece	Adapter Steel	Adapter Stainless Steel	PN (bar)
1/8-27	11	5	38	26	23	1/8 X 1.5 FFF-S	1/8X1.5FFFMSS	420
1/8-27	11	5	51	39	33	1/8 X 2.0 FFF-S	1/8X2.0FFFMSS	420
1/8-27	11	5	64	52	41	1/8 X 2.5 FFF-S	1/8X2.5FFFMSS	420
1/8-27	11	5	76	64	50	1/8 X 3.0 FFF-S	1/8X3.0FFFMSS	420
1/4-18	16	7	38	21	35	1/4 X 1.5 FFF-S	1/4X1.5FFFMSS	420
1/4-18	16	7	51	34	51	1/4 X 2.0 FFF-S	1/4X2.0FFFMSS	420
1/4-18	16	7	64	46	72	1/4 X 2.5 FFF-S	1/4X2.5FFFMSS	420
1/4-18	16	7	76	59	93	1/4 X 3.0 FFF-S	1/4X3.0FFFMSS	420
1/4-18	16	7	102	84	110	1/4 X 4.0 FFF-S	1/4X4.0FFFMSS	420
1/2-14	22	14	51	27	91	1/2 X 2.0 FFF-S	1/2X2.0FFFMSS	420
1/2-14	22	14	76	53	151	1/2 X 3.0 FFF-S	1/2X3.0FFFMSS	420

Order codes shown are part of our current manufacturing programme.
Imperial and metric parts may vary in hexagon dimensions.

$$\frac{\text{PN (bar)}}{10} = \text{PN (MPa)}$$

Pressure ratings – PN shown, apply to Steel and Stainless Steel versions of the product.

PTRM Thread reducer

Male NPTF* thread (SAE J476) / Female NPTF* thread (SAE J476)

SAE 140140

*Stainless Steel = NPT to prevent galling

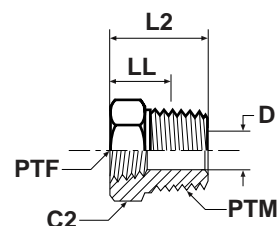

Thread NPT/NPTF PTM	Thread NPT/NPTF PTF	C2 mm	D mm	L2 mm	LL mm	Weight (steel) g/1 piece	Adapter Steel	Adapter Stainless Steel	PN (bar)
1/4-18	1/8-27	17	7	22	13	24	1/4X1/8PTRMS	1/4X1/8PTRMSS	420
3/8-18	1/8-27	19	8	22	13	25	3/8 X 1/8 PTR-S	3/8X1/8PTRMSS	420
3/8-18	1/4-18	19	10	22	13	25	3/8X1/4PTRMS	3/8X1/4PTRMSS	420
1/2-14	1/8-27	22	8	28	17	58	1/2 X 1/8 PTR-S	1/2X1/8PTRMSS	420
1/2-14	1/4-18	22	11	28	17	53	1/2 X 1/4PTRMS	1/2X1/4PTRMSS	420
1/2-14	3/8-18	22	14	28	17	40	1/2X3/8PTRMS	1/2X3/8PTRMSS	420
3/4-14	1/4-18	29	11	30	18	94	3/4 X 1/4 PTR-S	3/4X1/4PTRMSS	280
3/4-14	3/8-18	30	15	30	18	101	3/4X3/8PTRMS	3/4X3/8PTRMSS	380
3/4-14	1/2-14	30	18	30	18	110	3/4X1/2PTRMS	3/4X1/2PTRMSS	350
1-11 1/2	3/8-18	35	14	35	20	163	1 X 3/8 PTR-S	1X3/8PTRMSS	210
1-11 1/2	1/2-14	35	18	35	20	139	1 X 1/2 PTR-S	1X1/2PTRMSS	210
1-11 1/2	3/4-14	36	23	35	20	116	1X3/4PTRMS	1X3/4PTRMSS	280
1 1/4-11 1/2	1/2-14	45	18	37	22	220	1 1/4 X 1/2 PTR-S	11/4X1/2PTRMSS	170
1 1/4-11 1/2	3/4-14	45	23	37	22	236	1 1/4 X 3/4 PTR-S	11/4X3/4PTRMSS	170
1 1/4-11 1/2	1-11 1/2	46	29	37	22	250	1 1/4X1PTRMS	11/4X1PTRMSS	210
1 1/2-11 1/2	3/4-14	51	23	40	25	306	1 1/2 X 3/4 PTR-S	11/2X3/4PTRMSS	140
1 1/2-11 1/2	1-11 1/2	50	29	40	25	360	1 1/2X1PTRMS	11/2X1PTRMSS	210
1 1/2-11 1/2	1 1/4-11 1/2	50	38	40	25	282	1 1/2X1 1/4PTRMS	11/2X11/4PTRMSS	170
2-11 1/2	1/2-14	66	18	45	29	561	2 X 1/2 PTR-S	2X1/2PTRMSS	140
2-11 1/2	1 1/4-11 1/2	64	44	45	29	548	2 X 1 1/4 PTR-S	2X11/4PTRMSS	140

Order codes shown are part of our current manufacturing programme.
Imperial and metric parts may vary in hexagon dimensions.

$$\frac{\text{PN (bar)}}{10} = \text{PN (MPa)}$$

Pressure ratings – PN shown, apply to Steel and Stainless Steel versions of the product.

N

Adapters

FGM Thread expander / Adapter

Male NPTF* thread (SAE J476) / Female NPTF* thread (SAE J476)

SAE 140139

*Stainless Steel = NPT to prevent galling

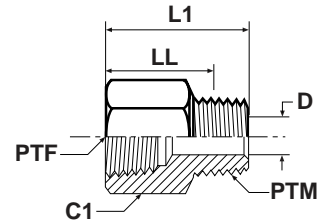

Thread NPT/NPTF PTF	Thread NPT/NPTF PTM	C1 mm	D mm	L1 mm	LL mm	Weight (steel) g/1 piece	Adapter Steel	Adapter Stainless Steel	PN (bar)
1/8-27	1/8-27	16	5	26	20	30	1/8 FG-S	1/8FGMSS	420
1/4-18	1/8-27	19	5	31	25	57	1/4 X 1/8 FG-S	1/4X1/8FGMSS	420
1/4-18	1/4-18	19	7	35	27	44	1/4 FG-S	1/4FGMSS	420
3/8-18	1/8-27	22	5	32	26	50	3/8 X 1/8 FG-S	3/8X1/8FGMSS	420
3/8-18	1/4-18	22	7	37	28	108	3/8 X 1/4 FG-S	3/8X1/4FGMSS	420
3/8-18	3/8-18	22	10	37	28	55	3/8 FG-S	3/8FGMSS	420
1/2-14	1/8-27	29	5	38	32	98	1/2 X 1/8 FG-S	1/2X1/8FGMSS	350
1/2-14	1/4-18	29	7	43	34	104	1/2 X 1/4 FG-S	1/2X1/4FGMSS	350
1/2-14	3/8-18	29	10	43	34	108	1/2 X 3/8 FG-S	1/2X3/8FGMSS	350
1/2-14	1/2-14	29	14	43	31	108	1/2 FG-S	1/2FGMSS	350
3/4-14	3/4-14	35	19	49	37	178	3/4 FG-S	3/4FGMSS	280
3/4-14	1/4-18	35	7	45	36	129	3/4 X 1/4 FG-S	3/4X1/4FGMSS	280
3/4-14	1/2-14	35	14	49	38	129	3/4 X 1/2FG-S	3/4X1/2FGMSS	280
1-11 1/2	1-11 1/2	42	24	60	46	160	1 FG-S	1FGMSS	210
1-11.1/2	1/2-14	41	14	56	44	180	1 X 1/2FG-S	1X1/2FGMSS	210
1-11.1/2	3/4-14	41	18	56	43	98	1 X 3/4FG-S	1X3/4FGMSS	210
1 1/4-11 1/2	1-11 1/2	51	24	63	48	296	1 1/4 X 1FG-S	11/4X1FGMSS	170

Order codes shown are part of our current manufacturing programme.
Imperial and metric parts may vary in hexagon dimensions.

$$\frac{\text{PN (bar)}}{10} = \text{PN (MPa)}$$

Pressure ratings – PN shown, apply to Steel and Stainless Steel versions of the product.

CDM Male female thread elbow

Male NPTF* thread (SAE J476) / Female NPTF* thread (SAE J476)

SAE 140239

*Stainless Steel = NPT to prevent galling

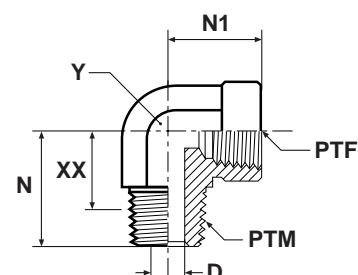

Thread NPT/NPTF PTF	Thread NPT/NPTF PTM	D mm	N mm	N1 mm	XX mm	Y mm	Weight (steel) g/1 piece	Adapter Steel	Adapter Stainless Steel	PN (bar)
1/8-27	1/8-27	5	20	17	14	14	30	1/8CDMS	1/8 CD-SS	350
1/4-18	1/4-18	7	28	22	19	19	77	1/4CDMS	1/4 CD-SS	350
1/4-18	1/8-27	7	28	17	19	14	33	1/4 X 1/8 CD-S	1/4 X 1/8 CD-SS	350
3/8-18	3/8-18	10	31	26	22	22	96	3/8CDMS	3/8 CD-SS	310
3/8-18	1/4-18	10	31	22	22	19	79	3/8 X 1/4 CD-S	3/8 X 1/4 CD-SS	350
3/8-18	1/2-14	10	33	31	24	27	260	3/8 X 1/2 CD-S	3/8 X 1/2 CD-SS	210
1/2-14	1/2-14	14	37	31	26	27	174	1/2CDMS	1/2 CD-SS	210
1/2-14	3/8-18	14	38	32	26	22	96	1/2 X 3/8 CD-S	1/2 X 3/8 CD-SS	310
1/2-14	3/4-14	14	40	35	29	33	319	1/2 X 3/4 CD-S	1/2 X 3/4 CD-SS	210
3/4-14	3/4-14	18	40	35	28	33	285	3/4CDMS	3/4 CD-SS	210
3/4-14	1/2-14	18	40	31	28	27	164	3/4 X 1/2 CD-S	3/4 X 1/2 CD-SS	210
1-11 1/2	1-11 1/2	24	50	41	36	41	515	1CDMS	1 CD-SS	125
1 1/4-11 1/2	1 1/4-11 1/2	32	61	43	46	48	978	1 1/4 CD-S	1 1/4 CD-SS	100
1 1/2-11 1/2	1 1/2-11 1/2	38	67	53	52	64	1679	1 1/2 CD-S	1 1/2 CD-SS	100

Order codes shown are part of our current manufacturing programme.
Imperial and metric parts may vary in hexagon dimensions.

$$\frac{\text{PN (bar)}}{10} = \text{PN (MPa)}$$

Pressure ratings – PN shown, apply to Steel and Stainless Steel versions of the product.

N

Adapters

CD45M Male female thread 45° elbow

Male NPTF* thread (SAE J476) / Female NPTF* thread (SAE J476)
SAE 140339

*Stainless Steel = NPT to prevent galling

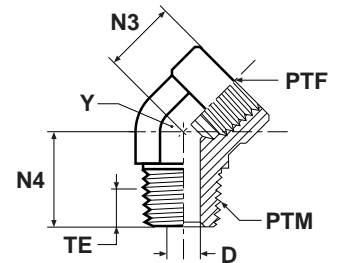

Thread NPT/NPTF PTM	Thread NPT/NPTF PTF	D mm	N3 mm	N4 mm	TE mm	Y mm	Weight (steel) g/1 piece	Adapter Steel	Adapter Stainless Steel	PN (bar)
1/8-27	1/8-27	5	12	18	6	14	24	1/8CD45MS	1/8 CD45-SS	350
1/4-18	1/4-18	7	16	27	9	19	57	1/4 CD45-S	1/4 CD45-SS	350
3/8-18	3/8-18	10	18	27	9	22	79	3/8 CD45-S	3/8 CD45-SS	310
1/2-14	1/2-14	14	23	34	12	27	141	1/2 CD45-S	1/2 CD45-SS	210
3/4-14	3/4-14	18	25	35	12	33	196	3/4 CD45-S	3/4 CD45-SS	210
1-11 1/2	1-11 1/2	24	29	44	15	41	380	1 CD45-S	1 CD45-SS	125
1 1/4-11 1/2	1 1/4-11 1/2	32	41	46	15	48	719	1 1/4 CD45-S	1 1/4 CD45-SS	100

Order codes shown are part of our current manufacturing programme.
Imperial and metric parts may vary in hexagon dimensions.

$$\frac{\text{PN (bar)}}{10} = \text{PN (MPa)}$$

Pressure ratings – PN shown, apply to Steel and Stainless Steel versions of the product.

MRO Male female thread tee

Male NPTF* thread (SAE J476) / Female NPTF* thread (SAE J476)

SAE 140424

*Stainless Steel = NPT to prevent galling

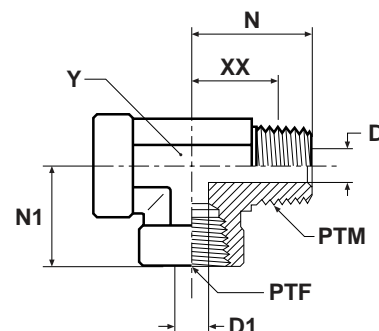

Thread NPT/NPTF PTM	Thread NPT/NPTF PTF	D mm	D1 mm	N mm	N1 mm	XX mm	Y mm	Weight (steel) g/1 piece	Adapter Steel	Adapter Stainless Steel	PN (bar)
1/8-27	1/8-27	5	8	20	17	14	14	59	1/8 MRO-S	1/8 MRO-SS	350
1/4-18	1/4-18	7	11	28	22	19	19	115	1/4 MRO-S	1/4 MRO-SS	350
3/8-18	3/8-18	10	14	31	26	22	22	122	3/8 MRO-S	3/8 MRO-SS	310
1/2-14	1/2-14	14	18	37	31	26	27	285	1/2 MRO-S	1/2 MRO-SS	210
3/4-14	3/4-14	18	23	40	35	28	33	497	3/4 MRO-S	3/4 MRO-SS	210
1-11 1/2	1-11 1/2	24	29	50	41	36	41	987	1 MRO-S	1 MRO-SS	125

Order codes shown are part of our current manufacturing programme.
Imperial and metric parts may vary in hexagon dimensions.

$$\frac{\text{PN (bar)}}{10} = \text{PN (MPa)}$$

Pressure ratings – PN shown, apply to Steel and Stainless Steel versions of the product.

Adapters

MMS Male female thread tee

Male NPTF* thread (SAE J476) / Female NPTF* thread (SAE J476)
SAE 140425

*Stainless Steel = NPT to prevent galling

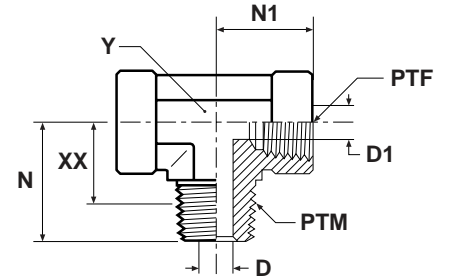

Thread NPT/NPTF PTM	Thread NPT/NPTF PTF	D mm	D1 mm	N mm	N1 mm	XX mm	Y mm	Weight (steel) g/1 piece	Adapter Steel	Adapter Stainless Steel	PN (bar)
1/8-27	1/8-27	5	8	20	17	14	14	45	1/8 MMS-S	1/8 MMS-SS	350
1/4-18	1/4-18	7	11	28	22	19	19	118	1/4 MMS-S	1/4 MMS-SS	350
3/8-18	3/8-18	10	14	31	26	22	22	126	3/8 MMS-S	3/8 MMS-SS	310
1/2-14	1/2-14	14	18	37	31	26	27	272	1/2 MMS-S	1/2 MMS-SS	210
3/4-14	3/4-14	18	23	40	35	28	33	408	3/4 MMS-S	3/4 MMS-SS	210
1-11 1/2	1-11 1/2	24	29	50	41	36	41	606	1 MMS-S	1 MMS-SS	125

Order codes shown are part of our current manufacturing programme.
Imperial and metric parts may vary in hexagon dimensions.

$$\frac{\text{PN (bar)}}{10} = \text{PN (MPa)}$$

Pressure ratings – PN shown, apply to Steel and Stainless Steel versions of the product.

GGM Female thread coupling

Female NPTF* thread (SAE J476) / Female NPTF* thread (SAE J476)

SAE 140138

*Stainless Steel = NPT to prevent galling

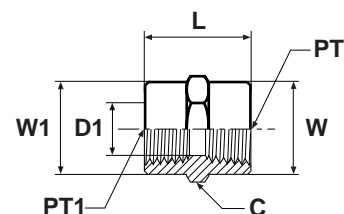

Thread NPT/NPTF PT	Thread NPT/NPTF PT1	C mm	D1 mm	L mm	W mm	W1 mm	Weight (steel) g/1 piece	Adapter Steel	Adapter Stainless Steel	PN (bar)
1/8-27	1/8-27	16	8	19	16	16	19	1/8 GG-S	1/8 GG-SS	420
1/4-18	1/8-27	19	8	24	19	16	35	1/4 X 1/8 GG-S	1/4 X 1/8 GG-SS	420
1/4-18	1/4-18	19	11	29	19	19	45	1/4 GG-S	1/4 GG-SS	420
3/8-18	1/8-27	22	8	26	22	16	56	3/8 X 1/8 GG-S	3/8 X 1/8 GG-SS	420
3/8-18	1/4-18	22	11	29	22	19	56	3/8 X 1/4 GG-S	3/8 X 1/4 GG-SS	420
3/8-18	3/8-18	22	14	29	22	22	62	3/8 GG-S	3/8 GG-SS	420
1/2-14	1/4-18	29	11	35	29	19	117	1/2 X 1/4 GG-S	1/2 X 1/4 GG-SS	350
1/2-14	3/8-18	29	14	38	29	22	100	1/2 X 3/8 GG-S	1/2 X 3/8 GG-SS	350
1/2-14	1/2-14	30	18	38	30	30	112	1/2 GG-S	1/2 GG-SS	350
3/4-14	1/4-18	35	11	39	35	19	150	3/4 X 1/4 GG-S	3/4 X 1/4 GG-SS	280
3/4-14	1/2-14	35	18	48	35	29	134	3/4 X 1/2 GG-S	3/4 X 1/2 GG-SS	280
3/4-14	3/4-14	36	23	39	36	36	156	3/4 GG-S	3/4 GG-SS	280
1-11 1/2	1-11 1/2	41	29	48	41	41	289	1 GG-S	1 GG-SS	210
1-11 1/2	1/2-14	42	18	45	41	29	235	1 X 1/2 GG-S	1 X 1/2 GG-SS	210
1-11 1/2	3/4-14	42	23	45	41	35	239	1 X 3/4 GG-S	1 X 3/4 GG-SS	210
1 1/4-11 1/2	1 1/4-11 1/2	51	37	49	51	51	340	1 1/4 GG-S	1 1/4 GG-SS	170
1 1/4-11 1/2	1-11 1/2	50	29	49	51	41	182	1 1/4 X 1 GG-S	1 1/4 X 1 GG-SS	170
1 1/2-11 1/2	1 1/2-11 1/2	60	43	49	61	61	706	1 1/2 GG-S	1 1/2 GG-SS	140
1 1/2-11 1/2	1 1/4-11 1/2	60	38	49	60	60	531	1 1/2 X 1 1/4 GG-S	1 1/2 X 1 1/4 GG-SS	140
2-11 1/2	2-11 1/2	73	56	50	73	73	814	2 GG-S	2 GG-SS	140

Order codes shown are part of our current manufacturing programme.
Imperial and metric parts may vary in hexagon dimensions.

$$\frac{\text{PN (bar)}}{10} = \text{PN (MPa)}$$

Pressure ratings – PN shown, apply to Steel and Stainless Steel versions of the product.

Adapters

DDM Female thread elbow

Female NPTF* thread (SAE J476)
SAE 140238

*Stainless Steel = NPT to prevent galling

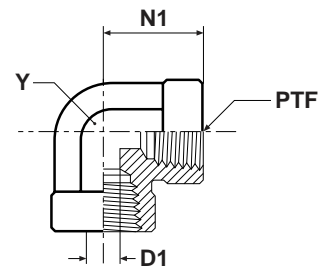

Thread NPT/NPTF PTF	D1 mm	N1 mm	Y mm	Weight (steel) g/1 piece	Adapter Steel	Adapter Stainless Steel	PN (bar)
1/8-27	9	17	14	28	1/8DDMS	1/8 DD-SS	350
1/4-18	11	22	19	28	1/4DDMS	1/4 DD-SS	350
3/8-18	15	26	22	96	3/8DDMS	3/8 DD-SS	310
1/2-14	18	31	27	159	1/2DDMS	1/2 DD-SS	210
3/4-14	23	35	41	263	3/4 DD-S	3/4 DD-SS	210
1-11 1/2	29	41	48	488	1 DD-S	1 DD-SS	125
1 1/4-11 1/2	37	43	48	978	1 1/4 DD-S	1 1/4 DD-SS	100
1 1/2-11 1/2	43	53	64	1889	1 1/2 DD-S	1 1/2 DD-SS	100

DD45 Female thread 45° elbow

Female NPTF* thread (SAE J476)
SAE 140338

*Stainless Steel = NPT to prevent galling

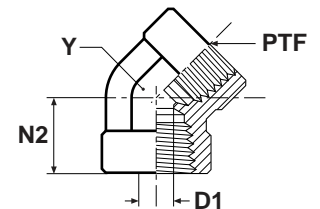

Thread NPT/NPTF PTF	D1 mm	N2 mm	Y mm	Weight (steel) g/1 piece	Adapter Steel	Adapter Stainless Steel	PN (bar)
1/4-18	11	18	19	69	1/4 DD45-S	1/4 DD45-SS	350
3/8-18	14	19	22	97	3/8 DD45-S	3/8 DD45-SS	310
1/2-14	18	24	27	172	1/2 DD45-S	1/2 DD45-SS	210
3/4-14	23	25	33	248	3/4 DD45-S	3/4 DD45-SS	210
1-11 1/2	29	30	41	479	1 DD45-S	1 DD45-SS	125

Order codes shown are part of our current manufacturing programme.
Imperial and metric parts may vary in hexagon dimensions.

$$\frac{\text{PN (bar)}}{10} = \text{PN (MPa)}$$

Pressure ratings – PN shown, apply to Steel and Stainless Steel versions of the product.

MMOM Female thread tee

Female NPTF* threads (SAE J476)

SAE 140438

*Stainless Steel = NPT to prevent galling

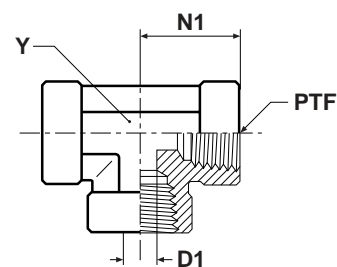

Thread NPT/NPTF PTF	D1 mm	N1 mm	Y mm	Weight (steel) g/1 piece	Adapter Steel	Adapter Stainless Steel	PN (bar)
1/8-27	8	17	14	36	1/8 MMO-S	1/8 MMO-SS	350
1/4-18	11	22	19	94	1/4 MMO-S	1/4 MMO-SS	350
3/8-18	14	26	22	121	3/8 MMO-S	3/8 MMO-SS	210
1/2-14	17	31	27	202	1/2MMOMS	1/2 MMO-SS	210
3/4-14	23	35	33	312	3/4MMOMS	3/4 MMO-SS	210
1-11 1/2	29	41	41	606	1 MMO-S	1 MMO-SS	125
1 1/4-11 1/2	37	43	48	576	1 1/4 MMO-S	1 1/4 MMO-SS	100
1 1/2-11 1/2	43	53	64	576	1 1/2 MMO-S	1 1/2 MMO-SS	100

KMMOO Female thread cross

Female NPTF* threads (SAE J476)

SAE 140538

*Stainless Steel = NPT to prevent galling

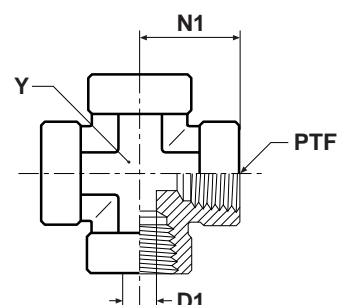

Thread NPT/NPTF PTF	D1 mm	N1 mm	Y mm	Weight (steel) g/1 piece	Adapter Steel	Adapter Stainless Steel	PN (bar)
1/8-27	8	17	14	45	1/8 KMMOO-S	1/8 KMMOO-SS	350
1/4-18	11	22	19	113	1/4 KMMOO-S	1/4 KMMOO-SS	350
3/8-18	14	26	22	147	3/8 KMMOO-S	3/8 KMMOO-SS	210
1/2-14	18	31	27	257	1/2 KMMOO-S	1/2 KMMOO-SS	210
3/4-14	23	35	33	382	3/4 KMMOO-S	3/4 KMMOO-SS	210
1-11 1/2	29	41	41	690	1 KMMOO-S	1 KMMOO-SS	125

Order codes shown are part of our current manufacturing programme.
Imperial and metric parts may vary in hexagon dimensions.

$$\frac{\text{PN (bar)}}{10} = \text{PN (MPa)}$$

Pressure ratings – PN shown, apply to Steel and Stainless Steel versions of the product.

Adapters

HPM Hexagon head plug

Male NPTF* Thread (SAE J476)
SAE 130109E

*Stainless Steel = NPT to prevent galling

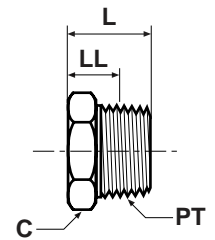

Thread NPT/NPTF PT	C mm	L mm	LL mm	Weight (steel) g/1 piece	Adapter Steel	Adapter Stainless Steel	PN (bar)
1/8-27	11	14	8	19	1/8 HP-S	1/8HPMSS	420
1/4-18	14	19	10	22	1/4 HP-S	1/4HPMSS	420
3/8-18	18	20	11	28	3/8 HP-S	3/8HPMSS	420
1/2-14	22	25	13	72	1/2 HP-S	1/2HPMSS	420
3/4-14	27	27	15	119	3/4 HP-S	3/4HPMSS	380
1-11 1/2	35	32	17	218	1 HP-S	1HPMSS	380
1 1/4-11 1/2	46	36	21	217	1 1/4 HP-S	11/4HPMSS	350
1 1/2-11 1/2	50	38	22	300	1 1/2 HP-S	11/2HPMSS	210

HHP Hexagon socket plug

Male NPTF* thread (SAE J476)
SAE 130109N

*Stainless Steel = NPT to prevent galling

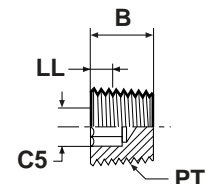

Thread NPT/NPTF PT	B mm	C5 inch	LL mm	Weight (steel) g/1 piece	Adapter Steel	Adapter Stainless Steel	PN (bar)
1/16-27	8	5/32	2	2	1/16 HHP-S	1/16 HHP-SS	420
1/8-27	8	3/16	2	3	1/8 HHP-S	1/8 HHP-SS	420
1/4-18	12	1/4	3	7	1/4 HHP-S	1/4 HHP-SS	420
3/8-18	12	5/16	3	13	3/8 HHP-S	3/8 HHP-SS	420
1/2-14	16	3/8	4	16	1/2 HHP-S	1/2 HHP-SS	420
3/4-14	16	9/16	4	66	3/4 HHP-S	3/4 HHP-SS	380
1-11 1/2	20	1 3/8	5	73	1 HHP-S	1 HHP-SS	380

Order codes shown are part of our current manufacturing programme.
Imperial and metric parts may vary in hexagon dimensions.

$$\frac{\text{PN (bar)}}{10} = \text{PN (MPa)}$$

Pressure ratings – PN shown, apply to Steel and Stainless Steel versions of the product.

F5OG Male female thread adapter

Male UN/UNF thread – O-ring (ISO 11926) / Female NPTF* thread (SAE 476)

*Stainless Steel = NPT to prevent galling

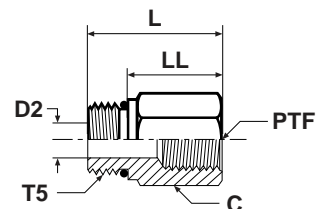

Thread UN/UNF-2A T5	Thread NPT/NPTF PTF	C mm	D2 mm	L mm	LL mm	Weight (steel) g/1 piece	Adapter Steel	Adapter Stainless Steel	PN (bar)
9/6-18	1/4-18	19	8	30	20	36	6-1/4 F5OG-S	6-1/4 F5OG-SS	420
3/4-16	1/4-18	22	10	29	18	53	8-1/4 F5OG-S	8-1/4 F5OG-SS	420
3/4-16	3/8-18	22	10	33	21	67	8-3/8 F5OG-S	8-3/8 F5OG-SS	420
3/4-16	1/2-14	29	10	38	27	98	8-1/2 F5OG-S	8-1/2 F5OG-SS	350
7/8-14	1/4-18	25	13	21	8	78	10-1/4 F5OG-S	10-1/4 F5OG-SS	380
7/8-14	3/8-18	25	13	33	21	77	10-3/8 F5OG-S	10-3/8 F5OG-SS	380
7/8-14	1/2-14	29	13	39	26	98	10-1/2 F5OG-S	10-1/2 F5OG-SS	350
7/8-14	3/4-14	35	13	41	29	153	10-3/4 F5OG-S	10-3/4 F5OG-SS	280
1 1/16-12	1/2-14	32	17	36	21	114	12-1/2 F5OG-S	12-1/2 F5OG-SS	350
1 1/16-12	3/4-14	35	17	44	29	150	12-3/4 F5OG-S	12-3/4 F5OG-SS	280
1 3/16-12	1/2-14	35	18	27	12	159	14-1/2 F5OG-S	14-1/2 F5OG-SS	280
1 3/16-12	3/4-14	35	18	43	28	167	14-3/4 F5OG-S	14-3/4 F5OG-SS	280
1 5/16-12	1/2-14	38	21	25	10	137	16-1/2 F5OG-S	16-1/2 F5OG-SS	280
1 5/16-12	3/4-14	38	21	38	23	189	16-3/4 F5OG-S	16-3/4 F5OG-SS	280
1 5/16-12	1-11 1/2	41	22	48	33	216	16-1 F5OG-S	16-1 F5OG-SS	210
1 5/8-12	1-11 1/2	48	27	25	10	151	20-1 F5OG-S	20-1 F5OG-SS	210
1 5/8-12	1 1/4-11 1/2	51	27	50	35	191	20-1 1/4 F5OG-S	20-1 1/4 F5OG-SS	170
1 7/8-12	1-11 1/2	54	34	25	10	612	24-1 F5OG-S	24-1 F5OG-SS	170
1 7/8-12	1 1/2-11 1/2	57	34	51	36	653	24-1 1/2 F5OG-S	24-1 1/2 F5OG-SS	140

Parker Adapter are delivered with NBR elastomeric seals as standard. For more details on other seal materials see page N61.

Order codes shown are part of our current manufacturing programme.

Imperial and metric parts may vary in hexagon dimensions.

$$\frac{\text{PN (bar)}}{10} = \text{PN (MPa)}$$

Pressure ratings – PN shown, apply to Steel and Stainless Steel versions of the product.

N

Adapters

AOEG Elbow

Male UN/UNF thread O-ring (ISO 11926) / Female NPTF thread (SAE 476)

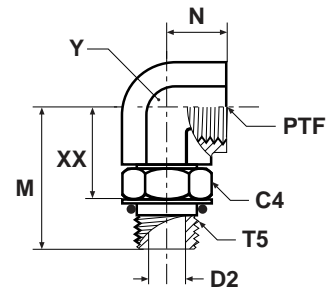

Thread UN/UNF-2A T5	Thread NPTF/NPTF PTF	C4 mm	D2 mm	M mm	N mm	XX mm	Y mm	Weight (steel) g/1 piece	Adapter Steel	PN (bar)
3/4-16	3/8-18	22	10	37	16	25	22	100	8-3/8 AOEG-S	310
7/8-14	1/2-14	25	12	46	19	32	27	172	10-1/2 AOEG-S	210
1 1/16-12	3/4-14	32	16	51	21	34	33	274	12-3/4 AOEG-S	210
1 5/16-12	1-11 1/2	38	21	57	25	41	41	471	16-1 AOEG-S	125

AOE4G Extra long elbow

Male UN/UNF thread O-ring (ISO 11926) / Female NPTF thread (SAE 476)

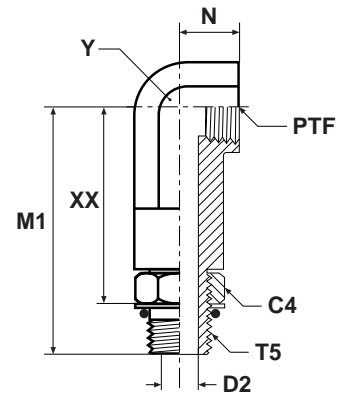

Thread UN/UNF-2A T5	Thread NPTF/NPTF PTF	C4 mm	D2 mm	M1 mm	N mm	XX mm	Y mm	Weight (steel) g/1 piece	Adapter Steel	PN (bar)
3/4-16	3/8-18	22	10	75	16	62	22	176	8-3/8 AOE4G-S	310
7/8-14	1/2-14	25	12	90	19	76	27	246	10-1/2 AOE4G-S	210
1 1/16-12	3/4-14	32	16	103	21	87	33	356	12-3/4 AOE4G-S	210
1 5/16-12	1-11 1/2	38	21	118	25	101	41	956	16-1 AOE4G-S	125

Parker Adapter are delivered with NBR elastomeric seals as standard. For more details on other seal materials see page N61.
Order codes shown are part of our current manufacturing programme.
Imperial and metric parts may vary in hexagon dimensions.

$$\frac{\text{PN (bar)}}{10} = \text{PN (MPa)}$$

Pressure ratings – PN shown, apply to the Steel version of the product.

F5OG5 Thread reducer / Expander

Male UN/UNF threads – O-ring (ISO 11926)
SAE 090136

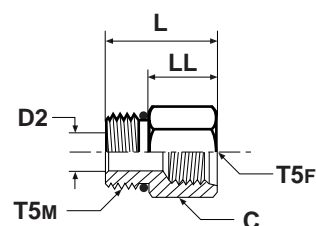

Thread UN/UNF-2A T5M	Thread UN/UNF-2B T5F	C mm	D2 mm	L mm	LL mm	Weight (steel) g/1 piece	Adapter Steel	Adapter Stainless Steel	PN (bar)
7/16-20	7/16-20	18	4	27	18	42	4-4 F5OG5-S	4-4 F5OG5-SS	500
7/16-20	9/16-18	21	4	30	20	49	4-6 F5OG5-S	4-6 F5OG5-SS	420
9/16-18	7/16-20	18	8	26	16	30	6-4 F5OG5-S	6-4 F5OG5-SS	500
9/16-18	3/4-16	27	8	35	25	64	6-8 F5OG5-S	6-8 F5OG5-SS	420
3/4-16	9/16-18	22	11	29	18	93	8-6 F5OG5-S	8-6 F5OG5-SS	420
3/4-16	7/8-14	29	10	40	29	73	8-10 F5OG5-S	8-10 F5OG5-SS	310
7/8-14	9/16-18	25	12	21	8	73	10-6 F5OG5-S	10-6 F5OG5-SS	420
7/8-14	3/4-16	25	14	33	21	75	10-8 F5OG5-S	10-8 F5OG5-SS	310
7/8-14	1 1/16-12	35	12	43	30	209	10-12 F5OG5-S	10-12 F5OG5-SS	310
1 1/16-12	3/4-16	32	16	25	10	114	12-8 F5OG5-S	12-8 F5OG5-SS	420
1 1/16-12	7/8-14	32	16	39	24	150	12-10 F5OG5-S	12-10 F5OG5-SS	350
1 1/16-12	1 5/16-12	41	16	48	33	170	12-16 F5OG5-S	12-16 F5OG5-SS	240
1 5/16-12	3/4-16	38	19	25	10	159	16-8 F5OG5-S	16-8 F5OG5-SS	310
1 5/16-12	7/8-14	38	20	25	10	240	16-10 F5OG5-S	16-10 F5OG5-SS	310
1 5/16-12	1 1/16-12	38	19	45	30	259	16-12 F5OG5-S	16-12 F5OG5-SS	310
1 5/16-12	1 5/8-12	54	22	50	35	280	16-20 F5OG5-S	16-20 F5OG5-SS	210
1 5/8-12	1 1/16-12	48	27	25	10	249	20-12 F5OG5-S	20-12 F5OG5-SS	280
1 5/8-12	1 5/16-12	48	27	25	10	249	20-16 F5OG5-S	20-16 F5OG5-SS	280
1 7/8-12	1 1/16-12	54	32	25	10	263	24-12 F5OG5-S	24-12 F5OG5-SS	210
1 7/8-12	1 5/16-12	54	32	25	10	268	24-16 F5OG5-S	24-16 F5OG5-SS	210
1 7/8-12	1 5/8-12	54	32	45	30	272	24-20 F5OG5-S	24-20 F5OG5-SS	210

Parker Adapter are delivered with NBR elastomeric seals as standard. For more details on other seal materials see page N61.
Order codes shown are part of our current manufacturing programme.
Imperial and metric parts may vary in hexagon dimensions.

$$\frac{\text{PN (bar)}}{10} = \text{PN (MPa)}$$

Pressure ratings – PN shown, apply to the Steel and Stainless Steel versions of the product.

N

Adapters

F5OHAO Straight thread union

Male UN/UNF threads – O-ring (ISO 11926)

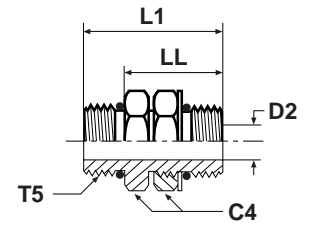

Thread UN/UNF-2A T5	C4 mm	D2 mm	L1 mm	LL mm	Weight (steel) g/1 piece	Adapter Steel	Adapter Stainless Steel	PN (bar)
7/16-20	14	5	31	12	25	4 F5OHAO-S	4 F5OHAO-SS	350
9/16-18	18	8	36	15	52	6 F5OHAO-S	6 F5OHAO-SS	350
3/4-16	22	11	40	16	76	8 F5OHAO-S	8 F5OHAO-SS	350
7/8-14	25	12	46	19	118	10 F5OHAO-S	10 F5OHAO-SS	310
1 1/16-12	32	17	54	23	213	12 F5OHAO-S	12 F5OHAO-SS	280
1 5/16-12	41	22	54	23	235	16 F5OHAO-S	16 F5OHAO-SS	210
1 5/8-12	48	28	54	23	367	20 F5OHAO-S	20 F5OHAO-SS	170
1 7/8-12	54	34	54	23	538	24 F5OHAO-S	24 F5OHAO-SS	140

G5G5JG5 Female straight thread tee

Female UN/UNF threads – all 3 ends

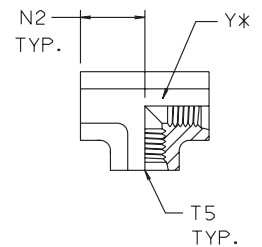

Thread UN/UNF-2B T5	N2 mm	Y mm	Weight (steel) g/1 piece	Adapter Steel	PN (bar)
7/16-20	19	19	68	4 G5G5JG5-S	350
9/16-18	22	19	47	6 G5G5JG5-S	350
3/4-16	26	27	228	8 G5G5JG5-S	350
7/8-14	30	27	228	10 G5G5JG5-S	310

Parker Adapter are delivered with NBR elastomeric seals as standard. For more details on other seal materials see page N61.
Order codes shown are part of our current manufacturing programme.
Imperial and metric parts may vary in hexagon dimensions.

$$\frac{\text{PN (bar)}}{10} = \text{PN (MPa)}$$

Pressure ratings – PN shown, apply to the Steel and Stainless Steel versions of the product.

P5ONM Hexagon head plug

Male UN/UNF thread – O-ring (ISO 11926)
SAE 090109A

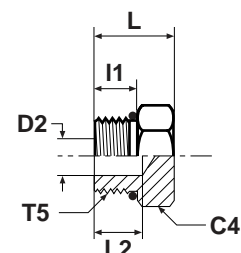

Thread UN/UNF-2A T5	C4 mm	D2 mm	l1 mm	L mm	L2 mm	Weight (steel) g/1 piece	Adapter Steel	Adapter Stainless Steel	PN (bar)
5/16-24	11	2	8	16	10	7	2 P5ON-S	2P5ONMSS	420
3/8-24	13	3	8	16	9	9	3 P5ON-S	3P5ONMSS	420
7/16-20	14	5	9	17	10	13	4 P5ON-S	4P5ONMSS	420
1/2-20	16	6	9	17	10	19	5P5ONMS	5P5ONMSS	420
9/16-18	18	8	10	19	11	22	6 P5ON-S	6P5ONMSS	420
3/4-16	22	11	11	20	11	44	8P5ONMS	8P5ONMSS	420
7/8-14	25	13	13	24	12	53	10 P5ON-S	10P5ONMSS	420
1 1/16-12	32	17	15	28	15	117	12 P5ON-S	12P5ONMSS	420
1 3/16-12	35	18	15	28	14	124	14 P5ON-S	14P5ONMSS	380
1 5/16-12	38	22	15	29	13	141	16 P5ON-S	16P5ONMSS	380
1 5/8-12	48	28	15	31	10	284	20 P5ON-S	20P5ONMSS	280
1 7/8-12	54	34	15	32	9	447	24 P5ON-S	24P5ONMSS	210
2 1/2-12	70	46	15	37	3	807	32 P5ON-S	32P5ONMSS	140

Parker Adapter are delivered with NBR elastomeric seals as standard. For more details on other seal materials see page N61.
Order codes shown are part of our current manufacturing programme.
Imperial and metric parts may vary in hexagon dimensions.

$$\frac{\text{PN (bar)}}{10} = \text{PN (MPa)}$$

Pressure ratings – PN shown, apply to the Steel and Stainless Steel versions of the product.

Adapters

HP50N Hexagon socket plug

Male UN/UNF thread – O-ring (ISO 11926)
SAE 090109B

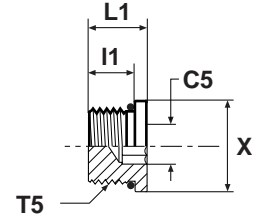

Thread UN/UNF-2A T5	C5 mm	l1 mm	L1 mm	X mm	Weight (steel) g/1 piece	Adapter Steel	Adapter Stainless Steel	PN (bar)
5/16-24	1/8	8	10	11	3	2 HP50N-S	2 HP50N-SS	420
3/8-24	1/8	8	10	13	5	3 HP50N-S	3 HP50N-SS	420
7/16-20	3/16	9	12	14	7	4 HP50N-S	4 HP50N-SS	420
1/2-20	3/16	9	12	16	10	5 HP50N-S	5 HP50N-SS	420
9/16-18	1/4	10	13	18	12	6 HP50N-S	6 HP50N-SS	420
3/4-16	5/16	11	15	22	26	8 HP50N-S	8 HP50N-SS	420
7/8-14	3/8	13	16	25	39	10 HP50N-S	10 HP50N-SS	420
1 1/16-12	9/16	15	19	32	64	12 HP50N-S	12 HP50N-SS	420
1 3/16-12	9/16	15	19	35	85	14 HP50N-S	14 HP50N-SS	380
1 5/16-12	5/8	15	19	38	103	16 HP50N-S	16 HP50N-SS	380
1 5/8-12	3/4	15	19	48	165	20 HP50N-S	20 HP50N-SS	280
1 7/8-12	3/4	15	20	54	238	24 HP50N-S	24 HP50N-SS	210

Parker Adapter are delivered with NBR elastomeric seals as standard. For more details on other seal materials see page N61.
Order codes shown are part of our current manufacturing programme.
Imperial and metric parts may vary in hexagon dimensions.

$$\frac{\text{PN (bar)}}{10} = \text{PN (MPa)}$$

Pressure ratings – PN shown, apply to the Steel and Stainless Steel versions of the product.

F3HMG5 Male female thread adapter

Male BSPT thread (ISO 7) / Female UN/UNF thread – O-ring (ISO 11926-1)

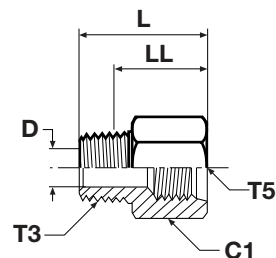

Thread BSPT T3	Thread UN/UNF-2B T5	C1 mm	D mm	L mm	LL mm	Weight (steel) g/1 piece	Adapter Steel	Adapter Stainless Steel	PN (bar)
1/8-28	7/16-20	18	5	28	22	27	1/8-4F3HG5-S	1/8-4F3HMG5SS	350
1/8-28	1/2-20	19	5	28	22	32	1/8-5F3HG5-S	1/8-5F3HMG5SS	350
1/4-19	9/16-18	21	7	35	26	45	1/4-6F3HG5-S	1/4-6F3HMG5SS	350
3/8-19	3/4-16	25	10	37	28	73	3/8-8F3HG5-S	3/8-8F3HMG5SS	315
1/2-14	7/8-14	29	14	45	34	111	1/2-10F3HG5-S	1/2-10F3HMG5SS	210
3/4-14	1 1/16-12	35	18	49	36	177	3/4-12F3HG5-S	3/4-12F3HMG5SS	210
1-11	1 5/16-12	41	24	54	39	272	1-16F3HG5-S	1-16F3HMG5SS	120

Order codes shown are part of our current manufacturing programme.
Imperial and metric parts may vary in hexagon dimensions.

$$\frac{\text{PN (bar)}}{10} = \text{PN (MPa)}$$

Pressure ratings – PN shown, apply to Steel and Stainless Steel versions of the product.

Adapters

F4OHMG5 Male female thread adapter

Male BSPP thread O-ring + retaining ring (ISO 1179) /
Female UN/UNF thread – O-ring (ISO 11926-1)

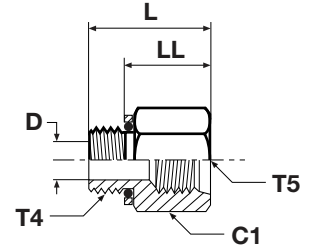

Thread BSPP T4	Thread UN/UNF-2B T5	C1 mm	D mm	L mm	LL mm	Weight (steel) g/1 piece	Adapter Steel	Adapter Stainless Steel	PN (bar)
1/8-28	7/16-20	18	4	25	19	27	1/8-4F4OHG5-S	1/8-4F4OHMG5SS	350
1/4-19	9/16-18	21	8	32	23	45	1/4-6F4OHG5-S	1/4-6F4OHMG5SS	350
3/8-19	9/16-18	22	8	32	23	70	3/8-6F4OHG5-S	3/8-6F4OHMG5SS	350
3/8-19	3/4-16	25	10	34	25	73	3/8-8F4OHG5-S	3/8-8F4OHMG5SS	350
1/2-14	7/8-14	29	12	41	29	111	1/2-10F4OHG5-S	1/2-10F4OHMG5SS	240
3/4-14	1 1/16-12	35	16	44	33	177	3/4-12F4OHG5-S	3/4-12F4OHMG5SS	240
1-11	1 5/16-12	45	21	49	34	272	1-16F4OHG5-S	1-16F4OHMG5SS	240
1 1/4-11	1 5/8-12	51	27	48	35	320	1 1/4-20F4OHG5-S	1 1/4-20F4OHMG5SS	140

Parker Adapter are delivered with NBR elastomeric seals as standard. For more details on other seal materials see page N61.
Order codes shown are part of our current manufacturing programme.
Imperial and metric parts may vary in hexagon dimensions.

$$\frac{\text{PN (bar)}}{10} = \text{PN (MPa)}$$

Pressure ratings – PN shown, apply to the Steel and Stainless Steel versions of the product.

F8OHMG5 Male female thread adapter

Male metric thread O-ring + retaining ring / Female UN/UNF thread – O-ring (ISO 11926-1)

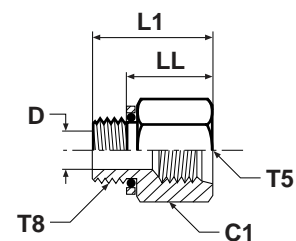

Thread Metric T8	Thread UN/UNF-2B T5	C1 mm	D mm	L1 mm	LL mm	Weight (steel) g/1 piece	Adapter Steel	Adapter Stainless Steel	PN (bar)
M10x1	7/16-20	18	4	27	20	27	M10X1-4F8OHG5-S	M10X1-4F8OHMG5SS	350
M14x1.5	9/16-18	21	7	30	23	45	M14X1.5-6F8OHG5-S	M14X1.5-6F8OHMG5SS	350
M16x1.5	3/4-16	25	9	33	24	73	M16X1.5-8F8OHG5-S	M16X1.5-8F8OHMG5SS	350
M22x1.5	7/8-14	29	13	38	26	111	M22X1.5-10F8OHG5-S	M22X1.5-10F8OHMG5SS	240
M27x2	1 1/16-12	32	16	48	34	170	M27X2-12F8OHG5-S	M27X2-12F8OHMG5SS	240
M33x2	1 5/16-12	41	22	49	35	250	M33X2-16 F8OHG5-S	M33X2-16F8OHMG5SS	140
M42x2	1 5/8-12	51	28	49	34	320	M42X2-20 F8OHG5-S	M42X2-20F8OHMG5SS	140

Parker Adapter are delivered with NBR elastomeric seals as standard. For more details on other seal materials see page N61.

Order codes shown are part of our current manufacturing programme.

Imperial and metric parts may vary in hexagon dimensions.

$$\frac{\text{PN (bar)}}{10} = \text{PN (MPa)}$$

Pressure ratings – PN shown, apply to the Steel and Stainless Steel versions of the product.

Adapters

HMK4 Union

BSPP 60° Cone end (ISO 8434-6)

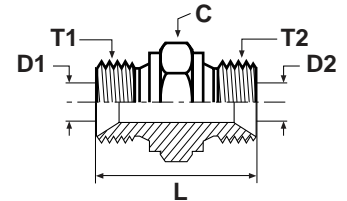

Thread BSPP T1	Thread BSPP T2	C mm	D1 mm	D2 mm	L mm	Weight (steel) g/1 piece	Adapter Steel	Adapter Stainless Steel	PN (bar)
1/8	1/8	14	4	4	24	15	2HMK4S	2HMK4SS	350
1/4	1/8	19	5	4	28	29	4-2HMK4S	4-2HMK4SS	350
1/4	1/4	19	5	5	32	35	4HMK4S	4HMK4SS	350
3/8	1/4	22	8	5	33	46	6-4HMK4S	6-4HMK4SS	350
3/8	3/8	22	8	8	35	51	6HMK4S	6HMK4SS	350
1/2	1/4	27	11	5	37	70	8-4HMK4S	8-4HMK4SS	200
1/2	3/8	27	11	8	38	76	8-6HMK4S	8-6HMK4SS	200
1/2	1/2	27	11	11	41	85	8HMK4S	8HMK4SS	200
5/8	1/2	30	14	11	43	106	10-8HMK4S	10-8HMK4SS	200
5/8	5/8	30	14	14	45	112	10HMK4S	10HMK4SS	200
3/4	1/4	32	17	5	39	92	12-4HMK4S	12-4HMK4SS	200
3/4	3/8	32	17	8	41	107	12-6HMK4S	12-6HMK4SS	200
3/4	1/2	32	17	11	43	111	12-8HMK4S	12-8HMK4SS	200
3/4	5/8	32	17	14	45	106	12-10HMK4S	12-10HMK4SS	200
3/4	3/4	32	17	17	45	124	12HMK4S	12HMK4SS	200
1	1/2	41	22	11	47	175	16-8HMK4S	16-8HMK4SS	120
1	5/8	41	22	14	49	188	16-10HMK4S	16-10HMK4SS	120
1	3/4	41	22	17	49	190	16-12HMK4S	16-12HMK4SS	120
1	1	41	22	22	52	199	16HMK4S	16HMK4SS	120
1 1/4	3/4	50	29	17	57	259	20-12HMK4S	20-12HMK4SS	105
1 1/4	1	50	29	22	60	383	20-16HMK4S	20-16HMK4SS	105
1 1/4	1 1/4	50	29	29	61	405	20HMK4S	20HMK4SS	105
1 1/2	1	55	33	22	64	417	24-16HMK4S	24-16HMK4SS	105
1 1/2	1 1/4	55	33	29	65	410	24-20HMK4S	24-20HMK4SS	105
1 1/2	1 1/2	55	33	33	67	534	24HMK4S	24HMK4SS	105
2	1 1/2	70	46	33	73	660	32-24HMK4S	32-24HMK4SS	70
2	2	70	46	46	76	719	32HMK4S	32HMK4SS	70

Order codes shown are part of our current manufacturing programme.
Imperial and metric parts may vary in hexagon dimensions.

$$\frac{\text{PN (bar)}}{10} = \text{PN (MPa)}$$

Pressure ratings – PN shown, apply to Steel and Stainless Steel versions of the product.

WMK4WL4NM Bulkhead union

BSPP 60° Cone end (ISO 8434-6)

* Supplied with locknut

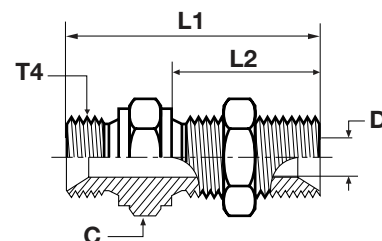

Thread BSPP T4	L1 mm	L2 mm	C mm	D mm	Weight (steel) g/1 piece	Adapter Steel	Adapter Stainless Steel	PN (bar)
1/4	49	28	19	5	57	4WMK4WL4NMS	4WMK4WL4NMSS	350
3/8	55	32	22	8	84	6WMK4WL4NMS	6WMK4WL4NMSS	350
1/2	62	35	27	11	122	8WMK4WL4NMS	8WMK4WL4NMSS	200
5/8	64	35	30	14	146	10WMK4WL4NMS	10WMK4WL4NMSS	200
3/4	67	38	32	17	209	12WMK4WL4NMS	12WMK4WL4NMSS	200
1	74	41	41	22	328	16WMK4WL4NMS	16WMK4WL4NMSS	120
1 1/4	85	44	50	29	507	20WMK4WL4NMS	20WMK4WL4NMSS	105
1 1/2	93	48	55	33	609	24WMK4WL4NMS	24WMK4WL4NMSS	105

Order codes shown are part of our current manufacturing programme.
Imperial and metric parts may vary in hexagon dimensions.
For the version without locknut, please delete "WL4NM" (e.g. 16WMK4)

$$\frac{\text{PN (bar)}}{10} = \text{PN (MPa)}$$

Pressure ratings – PN shown, apply to the Steel and Stainless Steel versions of the product.

Maximum bulkhead wall thickness

Thread BSPP	Bulkhead union Max. thickness mm
1/4	9.5
3/8	12.5
1/2	12.4
5/8	10.8
3/4	13.4
1	10.1
1 1/4	12.1
1 1/2	14.1

Adapters

EMK4 Union elbow

BSPP 60° Cone end (ISO 8434-6)

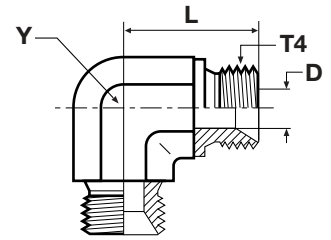

Thread BSPP T4	D mm	L mm	Y mm	Weight (steel) g/1 piece	Adapter Steel	Adapter Stainless Steel	PN (bar)
1/8	4	17	11	21	2EMK4S	2EMK4SS	350
1/4	5	24	14	45	4EMK4S	4EMK4SS	350
3/8	8	27	19	85	6EMK4S	6EMK4SS	350
1/2	11	32	22	123	8EMK4S	8EMK4SS	200
5/8	14	34	22	109	10EMK4S	10EMK4SS	200
3/4	17	36	27	178	12EMK4S	12EMK4SS	200
1	22	42	33	288	16EMK4S	16EMK4SS	120
1 1/4	29	48	41	512	20EMK4S	20EMK4SS	105
1 1/2	33	54	48	824	24EMK4S	24EMK4SS	105

JMK4 Union tee

BSPP 60° Cone end (ISO 8434-6)

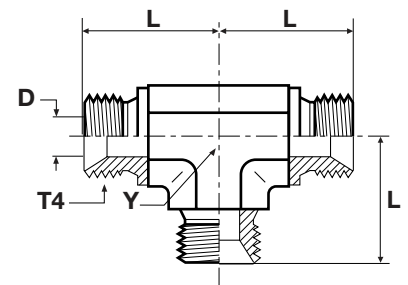

Thread BSPP T4	D mm	L mm	Y mm	Weight (steel) g/1 piece	Adapter Steel	Adapter Stainless Steel	PN (bar)
1/8	4	17	11	33	2JMK4S	2JMK4SS	350
1/4	5	24	14	61	4JMK4S	4JMK4SS	350
3/8	8	27	19	105	6JMK4S	6JMK4SS	350
1/2	11	32	22	157	8JMK4S	8JMK4SS	200
5/8	14	34	22	145	10JMK4S	10JMK4SS	200
3/4	17	36	27	258	12JMK4S	12JMK4SS	200
1	22	42	33	591	16JMK4S	16JMK4SS	120
1 1/4	29	48	41	646	20JMK4S	20JMK4SS	105
1 1/2	33	54	48	940	24JMK4S	24JMK4SS	105

Order codes shown are part of our current manufacturing programme.
Imperial and metric parts may vary in hexagon dimensions.

$$\frac{\text{PN (bar)}}{10} = \text{PN (MPa)}$$

Pressure ratings – PN shown, apply to Steel and Stainless Steel versions of the product.

PNMK4 Plug

BSPP 60° Cone plug (ISO 8434-6)

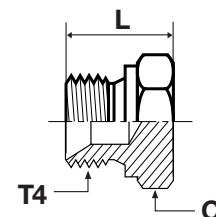

Thread BSPP T4	C mm	L mm	Weight (steel) g/1 piece	Adapter Steel	Adapter Stainless Steel	PN (bar)
1/8	14	14	11	2PNMK4S	2PNMK4SS	350
1/4	19	19	22	4PNMK4S	4PNMK4SS	350
3/8	22	21	38	6PNMK4S	6PNMK4SS	350
1/2	27	24	66	8PNMK4S	8PNMK4SS	200
5/8	30	27	76	10PNMK4S	10PNMK4SS	200
3/4	32	27	106	12PNMK4S	12PNMK4SS	200
1	41	30	170	16PNMK4S	16PNMK4SS	120
1 1/4	50	39	316	20PNMK4S	20PNMK4SS	105
1 1/2	55	43	386	24PNMK4S	24PNMK4SS	105
2	70	48	650	32PNMK4S	32PNMK4SS	70

Order codes shown are part of our current manufacturing programme.
Imperial and metric parts may vary in hexagon dimensions.

$$\frac{\text{PN (bar)}}{10} = \text{PN (MPa)}$$

Pressure ratings – PN shown, apply to Steel and Stainless Steel versions of the product.

Adapters

F6MK4 Swivel male stud

BSPP 60° cone end (ISO 8434-6) / BSPP 60° Female swivel end (ISO 8434-6)

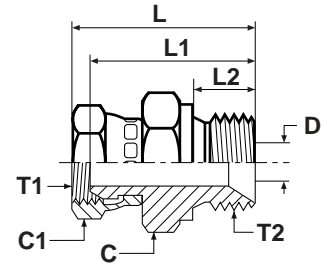

Thread BSPP T1	Thread BSPP T2	C mm	C1 mm	D mm	L mm	L1 mm	L2 mm	Weight (steel) g/1 piece	Adapter Steel	Adapter Stainless Steel	PN (bar)
1/4	1/4	19	19	5	37	31	11	44	4-4F6MK4S	4-4F6MK4SS	350
1/4	3/8	22	19	8	39	33	12	61	4-6F6MK4S	4-6F6MK4SS	350
1/4	1/2	27	19	11	42	36	14	75	4-8F6MK4S	4-8F6MK4SS	200
3/8	1/4	19	22	5	38	32	11	59	6-4F6MK4S	6-4F6MK4SS	350
3/8	3/8	22	22	8	40	34	12	71	6-6F6MK4S	6-6F6MK4SS	350
3/8	1/2	27	22	11	44	37	14	92	6-8F6MK4S	6-8F6MK4SS	200
1/2	3/8	22	27	8	44	37	12	102	8-6F6MK4S	8-6F6MK4SS	200
1/2	1/2	27	27	11	46	39	14	143	8-8F6MK4S	8-8F6MK4SS	200
1/2	3/4	32	27	17	50	42	16	157	8-12F6MK4S	8-12F6MK4SS	200
3/4	1/2	27	32	11	47	39	14	171	12-8F6MK4S	12-8F6MK4SS	200
3/4	3/4	32	32	17	50	41	16	165	12-12F6MK4S	12-12F6MK4SS	200
3/4	1	41	32	22	55	45	19	261	12-16F6MK4S	12-16F6MK4SS	120
1	1	41	41	22	57	46	19	300	16-16F6MK4S	16-16F6MK4SS	120

Order codes shown are part of our current manufacturing programme.
Imperial and metric parts may vary in hexagon dimensions.

$$\frac{\text{PN (bar)}}{10} = \text{PN (MPa)}$$

Pressure ratings – PN shown, apply to Steel and Stainless Steel versions of the product.

C6MK4 Swivel nut elbow

BSPP 60° cone end (ISO 8434-6) / BSPP 60° Female swivel end (ISO 8434-6)

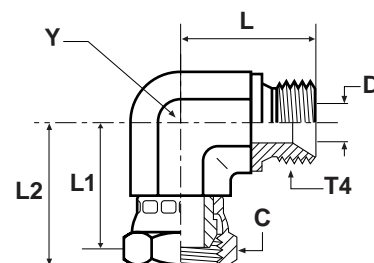

Thread BSPP T4	C mm	D mm	L mm	L1 mm	L2 mm	Y mm	Weight (steel) g/1 piece	Adapter Steel	Adapter Stainless Steel	PN (bar)
1/8	14	4	17	18	22	11	26	2C6MK4S	2C6MK4SS	350
1/4	19	5	24	25	31	14	62	4C6MK4S	4C6MK4SS	350
3/8	22	8	27	26	33	19	104	6C6MK4S	6C6MK4SS	350
1/2	27	11	32	32	39	22	159	8C6MK4S	8C6MK4SS	200
5/8	30	14	34	30	40	22	158	10C6MK4S	10C6MK4SS	200
3/4	32	17	36	33	42	27	226	12C6MK4S	12C6MK4SS	200
1	41	22	42	38	49	33	377	16C6MK4S	16C6MK4SS	120
1 1/4	50	29	48	48	58	41	650	20C6MK4S	20C6MK4SS	105
1 1/2	60	33	54	50	63	48	999	24C6MK4S	24C6MK4SS	105

Order codes shown are part of our current manufacturing programme.
Imperial and metric parts may vary in hexagon dimensions.

$$\frac{\text{PN (bar)}}{10} = \text{PN (MPa)}$$

Pressure ratings – PN shown, apply to Steel and Stainless Steel versions of the product.

Adapters

R6MK4 Swivel nut run tee

BSPP 60° Cone ends (ISO 8434-6) / BSPP 60° Female swivel end (ISO 8434-6)

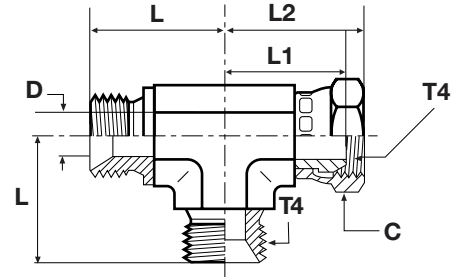

Thread BSPP T4	C mm	D mm	L mm	L1 mm	L2 mm	Y mm	Weight (steel) g/1 piece	Adapter Steel	Adapter Stainless Steel	PN (bar)
1/8	14	4	17	18	22	11	29	2R6MK4S	2R6MK4SS	350
1/4	19	5	24	25	31	14	77	4R6MK4S	4R6MK4SS	350
3/8	22	8	27	26	32	19	128	6R6MK4S	6R6MK4SS	350
1/2	27	11	32	32	39	22	203	8R6MK4S	8R6MK4SS	200
5/8	30	14	34	30	40	22	274	10R6MK4S	10R6MK4SS	200
3/4	32	17	36	33	42	27	274	12R6MK4S	12R6MK4SS	200
1	41	22	42	38	48	33	456	16R6MK4S	16R6MK4SS	120
1 1/4	50	29	48	48	58	41	801	20R6MK4S	20R6MK4SS	105

Order codes shown are part of our current manufacturing programme.
Imperial and metric parts may vary in hexagon dimensions.

$$\frac{\text{PN (bar)}}{10} = \text{PN (MPa)}$$

Pressure ratings – PN shown, apply to Steel and Stainless Steel versions of the product.

S6MK4 Swivel nut branch tee

BSPP 60° Cone ends (ISO 8434-6) / BSPP 60° Female swivel end (ISO 8434-6)

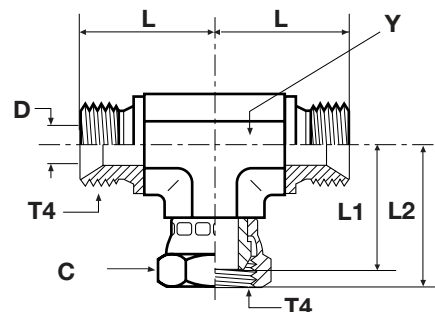

Thread BSPP T4	C mm	D mm	L mm	L1 mm	L2 mm	Y mm	Weight (steel) g/1 piece	Adapter Steel	Adapter Stainless Steel	PN (bar)
1/8	14	4	17	18	22	11	33	2S6MK4S	2S6MK4SS	350
1/4	19	5	24	25	31	14	77	4S6MK4S	4S6MK4SS	350
3/8	22	8	27	26	32	19	126	6S6MK4S	6S6MK4SS	350
1/2	27	11	32	32	39	22	191	8S6MK4S	8S6MK4SS	200
5/8	30	14	34	30	40	22	209	10S6MK4S	10S6MK4SS	200
3/4	32	17	36	33	42	27	286	12S6MK4S	12S6MK4SS	200
1	41	22	42	38	48	33	493	16S6MK4S	16S6MK4SS	120
1 1/4	50	29	48	48	58	41	796	20S6MK4S	20S6MK4SS	105

Order codes shown are part of our current manufacturing programme.
Imperial and metric parts may vary in hexagon dimensions.

$$\frac{\text{PN (bar)}}{10} = \text{PN (MPa)}$$

Pressure ratings – PN shown, apply to Steel and Stainless Steel versions of the product.

Adapters

H6MK4 Swivel nut union

BSPP 60° Female swivel ends (ISO 8434-6)

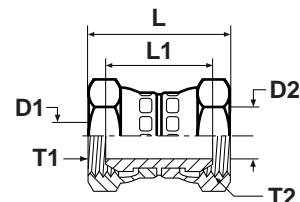

Thread BSPP T1	Thread BSPP T2	D1 mm	D2 mm	L mm	L1 mm	Weight (steel) g/1 piece	Adapter Steel	Adapter Stainless Steel	PN (bar)
1/4	1/4	5	5	38	27	50	4H6MK4S	4H6MK4SS	350
3/8	1/4	8	5	40	28	61	6-4H6MK4S	6-4H6MK4SS	350
3/8	3/8	8	8	42	29	73	6H6MK4S	6H6MK4SS	350
1/2	1/4	11	5	43	30	85	8-4H6MK4S	8-4H6MK4SS	200
1/2	3/8	11	8	44	31	96	8-6H6MK4S	8-6H6MK4SS	200
1/2	1/2	11	11	47	33	107	8H6MK4S	8H6MK4SS	200
5/8	5/8	14	14	48	29	130	10H6MK4S	10H6MK4SS	200
3/4	1/2	17	11	49	33	152	12-8H6MK4S	12-8H6MK4SS	200
3/4	3/4	17	17	50	32	167	12H6MK4S	12H6MK4SS	200
1	1	22	22	58	35	201	16H6MK4S	16H6MK4SS	120
1 1/4	1 1/4	29	29	66	45	340	20H6MK4S	20H6MK4SS	105
1 1/2	1 1/2	33	33	70	43	583	24H6MK4S	24H6MK4SS	105

Order codes shown are part of our current manufacturing programme.
Imperial and metric parts may vary in hexagon dimensions.

$$\frac{\text{PN (bar)}}{10} = \text{PN (MPa)}$$

Pressure ratings – PN shown, apply to Steel and Stainless Steel versions of the product.

E6MK4 Swivel nut elbow

BSPP 60° Female swivel ends (ISO 8434-6)

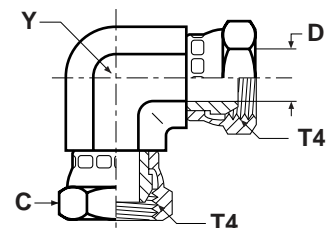

Thread BSPP T4	C mm	D mm	L mm	L1 mm	Y mm	Weight (steel) g/1 piece	Adapter Steel	Adapter Stainless Steel	PN (bar)
1/4	19	5	31	25	14	90	4E6MK4S	4E6MK4SS	350
3/8	22	8	33	26	19	127	6E6MK4S	6E6MK4SS	350
1/2	27	11	39	32	22	225	8E6MK4S	8E6MK4SS	200
5/8	30	14	39	30	22	203	10E6MK4S	10E6MK4SS	200
3/4	32	17	42	33	27	263	12E6MK4S	12E6MK4SS	200
1	41	22	49	38	33	667	16E6MK4S	16E6MK4SS	120
1 1/4	50	29	58	48	41	795	20E6MK4S	20E6MK4SS	105
1 1/2	60	33	63	50	48	1219	24E6MK4S	24E6MK4SS	105

Order codes shown are part of our current manufacturing programme.
Imperial and metric parts may vary in hexagon dimensions.

$$\frac{\text{PN (bar)}}{10} = \text{PN (MPa)}$$

Pressure ratings – PN shown, apply to Steel and Stainless Steel versions of the product.

Adapters

J6MK4 Swivel nut tee

BSPP 60° Female swivel ends (ISO 8434-6)

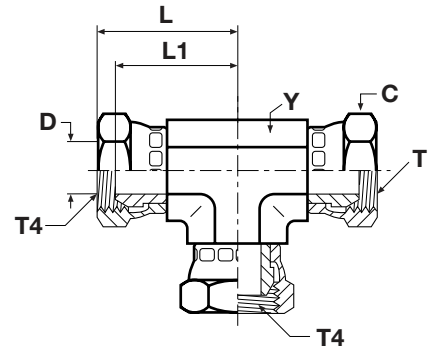

Thread BSPP T4	C mm	D mm	L mm	L1 mm	Y mm	Weight (steel) g/1 piece	Adapter Steel	Adapter Stainless Steel	PN (bar)
1/4	19	5	31	25	14	119	4J6MK4S	4J6MK4SS	350
3/8	22	8	36	30	19	195	6J6MK4S	6J6MK4SS	350
1/2	27	11	39	32	22	267	8J6MK4S	8J6MK4SS	200
5/8	30	14	39	30	22	300	10J6MK4S	10J6MK4SS	200
3/4	32	17	42	33	27	398	12J6MK4S	12J6MK4SS	200
1	41	22	49	38	33	620	16J6MK4S	16J6MK4SS	120
1 1/4	50	29	58	48	41	1050	20J6MK4S	20J6MK4SS	105

Order codes shown are part of our current manufacturing programme.
Imperial and metric parts may vary in hexagon dimensions.

$$\frac{\text{PN (bar)}}{10} = \text{PN (MPa)}$$

Pressure ratings – PN shown, apply to Steel and Stainless Steel versions of the product.

G4MK4 Female connector

BSPP 60° Cone end (ISO8434-6) / Female BSPP thread (ISO1179-1)

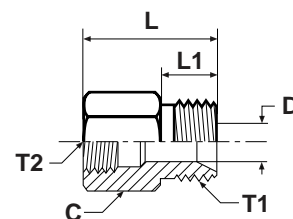

Thread BSPP T1	Thread BSPP T2	C mm	D mm	L mm	L1 mm	Weight (steel) g/1 piece	Adapter Steel	Adapter Stainless Steel	PN (bar)
3/8	1/4	22	8	36	12	74	6G4MK4S	6G4MK4SS	350
1/2	1/4	27	11	38	14	77	8-4G4MK4S	8-4G4MK4SS	200
1/2	3/8	22	11	40	14	102	8G4MK4S	8G4MK4SS	200
3/4	1/4	32	17	40	16	180	12-4G4MK4S	12-4G4MK4SS	200
3/4	3/8	32	17	42	16	167	12-6G4MK4S	12-6G4MK4SS	200
3/4	1/2	32	17	48	16	209	12-8G4MK4S	12-8G4MK4SS	200
1	1/4	41	22	43	19	298	16-4G4MK4S	16-4G4MK4SS	120
1	3/8	41	22	45	19	287	16-6G4MK4S	16-6G4MK4SS	120
1	1/2	41	22	51	19	275	16-8G4MK4S	16-8G4MK4SS	120
1	3/4	41	22	52	19	360	16-12G4MK4S	16-12G4MK4SS	120

Order codes shown are part of our current manufacturing programme.
Imperial and metric parts may vary in hexagon dimensions.

$$\frac{\text{PN (bar)}}{10} = \text{PN (MPa)}$$

Pressure ratings – PN shown, apply to Steel and Stainless Steel versions of the product.

N

Adapters

F3MK4 Male stud connector

BSPP 60° Cone end (ISO 8434-6) / Male BSPT thread (ISO 7)

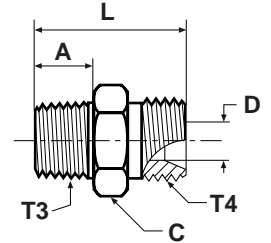

Thread BSPP T4	Thread BSPT T3	A mm	C mm	D mm	L mm	Weight (steel) g/1 piece	Adapter Steel	Adapter Stainless Steel	PN (bar)
1/8	1/8	10	14	4	24	15	2F3MK4S	2F3MK4SS	315
1/8	1/4	15	14	4	29	28	2-4F3MK4S	2-4F3MK4SS	315
1/4	1/4	15	19	5	33	31	4-4F3MK4S	4-4F3MK4SS	315
1/4	1/8	10	19	5	29	27	4F3MK4S	4F3MK4SS	315
1/4	3/8	15	19	5	33	44	4-6F3MK4S	4-6F3MK4SS	315
3/8	3/8	15	22	8	35	52	6-6F3MK4S	6-6F3MK4SS	315
3/8	1/2	19	22	8	40	68	6-8F3MK4S	6-8F3MK4SS	160
3/8	1/4	15	22	7	35	48	6F3MK4S	6F3MK4SS	315
1/2	1/2	19	27	11	43	79	8-8F3MK4S	8-8F3MK4SS	160
1/2	3/8	15	27	11	39	68	8F3MK4S	8F3MK4SS	200
5/8	1/2	19	30	14	46	101	10F3MK4S	10F3MK4SS	200
5/8	3/4	19	30	14	46	102	10-12F3MK4S	10-12F3MK4SS	160
3/4	1/2	19	32	17	46	111	12-8F3MK4S	12-8F3MK4SS	315
3/4	3/4	19	32	17	46	126	12F3MK4S	12F3MK4SS	160
3/4	1	24	36	17	51	242	12-16F3MK4S	12-16F3MK4SS	120
1	3/4	19	41	22	50	173	16-12F3MK4S	16-12F3MK4SS	120
1	1	24	41	22	55	219	16F3MK4S	16F3MK4SS	120
1 1/4	1 1/4	25	50	29	64	337	20F3MK4S	20F3MK4SS	105
1 1/2	1 1/2	26	55	33	69	497	24F3MK4S	24F3MK4SS	105

Order codes shown are part of our current manufacturing programme.
Imperial and metric parts may vary in hexagon dimensions.

$$\frac{\text{PN (bar)}}{10} = \text{PN (MPa)}$$

Pressure ratings – PN shown, apply to Steel and Stainless Steel versions of the product.

FNMK4 Cap

BSPP 60° Cone female swivel cap end

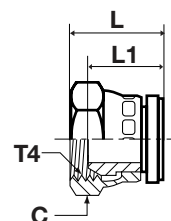

Thread BSPP T4	C mm	L mm	L1 mm	Weight (steel) g/1 piece	Adapter Steel	Adapter Stainless Steel	PN (bar)
1/8	14	15	11	19	2FNMK4S	2FNMK4SS	350
1/4	19	20	15	23	4FNMK4S	4FNMK4SS	350
3/8	22	22	15	43	6FNMK4S	6FNMK4SS	350
1/2	27	22	18	64	8FNMK4S	8FNMK4SS	200
5/8	30	25	16	80	10FNMK4S	10FNMK4SS	200
3/4	32	26	17	115	12FNMK4S	12FNMK4SS	200
1	41	30	19	154	16FNMK4S	16FNMK4SS	120
1 1/4	50	34	24	345	20FNMK4S	20FNMK4SS	105
1 1/2	60	36	23	500	24FNMK4S	24FNMK4SS	105

Order codes shown are part of our current manufacturing programme.
Imperial and metric parts may vary in hexagon dimensions.

$$\frac{\text{PN (bar)}}{10} = \text{PN (MPa)}$$

Pressure ratings – PN shown, apply to Steel and Stainless Steel versions of the product.

Adapters

FMK4 Male stud connector

BSPP 60° Cone end (ISO 8434-6) / Male NPTF* thread (SAE J476)

*Stainless Steel = NPT to prevent galling

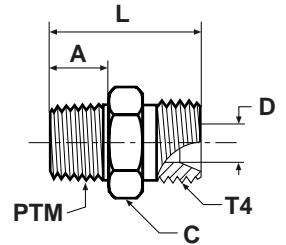

Thread BSPP T4	Thread NPT/NPTF PTM	A mm	C mm	D mm	L mm	Weight (steel) g/1 piece	Adapter Steel	Adapter Stainless Steel	PN (bar)
1/8	1/8	10	14	4	24	17	2FMK4S	2FMK4SS	350
1/8	1/4	15	19	4	29	21	2-4FMK4S	2-4FMK4SS	350
1/4	1/8	10	19	5	29	24	4FMK4S	4FMK4SS	350
1/4	1/4	15	19	5	33	33	4-4FMK4S	4-4FMK4SS	350
1/4	3/8	15	19	5	34	41	4-6FMK4S	4-6FMK4SS	350
3/8	1/4	15	22	8	35	45	6FMK4S	6FMK4SS	350
3/8	3/8	15	2	8	35	50	6-6FMK4S	6-6FMK4SS	350
3/8	1/2	19	22	8	40	77	6-8FMK4S	6-8FMK4SS	350
1/2	3/8	15	27	11	39	48	8FMK4S	8FMK4SS	200
1/2	1/2	19	27	11	43	93	8-8FMK4S	8-8FMK4SS	200
1/2	3/4	19	27	11	44	95	8-12FMK4S	8-12FMK4SS	200
3/4	1/2	19	32	17	46	112	12-8FMK4S	12-8FMK4SS	200
3/4	3/4	19	32	17	46	124	12FMK4S	12FMK4SS	200
3/4	1	24	36	17	51	150	12-16FMK4S	12-16FMK4SS	200
1	3/4	19	41	22	50	188	16-12FMK4S	16-12FMK4SS	120
1	1	24	41	22	55	234	16FMK4S	16FMK4SS	120

Order codes shown are part of our current manufacturing programme.
Imperial and metric parts may vary in hexagon dimensions.

$$\frac{\text{PN (bar)}}{10} = \text{PN (MPa)}$$

Pressure ratings – PN shown, apply to Steel and Stainless Steel versions of the product.

GG44M Female thread coupling

Female BSPP thread (ISO 1179-1)

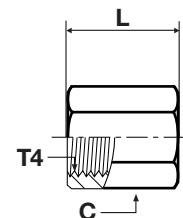

Thread BSPP T4	C mm	L mm	Weight (steel) g/1 piece	Adapter Steel	Adapter Stainless Steel	PN (bar)
1/8	14	19	16	1/8GG44MS	1/8GG44MSS	420
1/4	17	28	30	1/4GG44MS	1/4GG44MSS	420
3/8	22	28	47	3/8GG44MS	3/8GG44MSS	420
1/2	27	33	78	1/2GG44MS	1/2GG44MSS	350
3/4	32	37	105	3/4GG44MS	3/4GG44MSS	280
1	43	42	341	1GG44MS	1GG44MSS	210

Order codes shown are part of our current manufacturing programme.
Imperial and metric parts may vary in hexagon dimensions.

$$\frac{\text{PN (bar)}}{10} = \text{PN (MPa)}$$

Pressure ratings – PN shown, apply to Steel and Stainless Steel versions of the product.

N

Adapters

MMO444M Female thread tee

Female BSPP threads (ISO 1179-1)

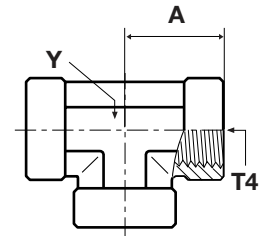

Thread BSPP T4	A mm	Y mm	Weight (steel) g/1 piece	Adapter Steel	PN (bar)
1/4	22	19	74	1/4MMO444MS	350
3/8	26	22	111	3/8MMO444MS	315
1/2	31	27	177	1/2MMO444MS	210
3/4	40	33	294	3/4MMO444MS	210
1	46	41	567	1MMO444MS	120

Order codes shown are part of our current manufacturing programme.
Imperial and metric parts may vary in hexagon dimensions.

$$\frac{\text{PN (bar)}}{10} = \text{PN (MPa)}$$

Pressure ratings – PN shown, apply to the Steel version of the product.

PTR44M* Thread reducer

Male BSPP thread O-ring + retaining ring (ISO 1179) / Female BSPP thread (ISO 1179-1)

*To Be Phased out, Replaced by RI-ED Range ** See chapter I

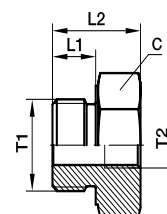

Thread BSPP T1	Thread BSPP T2	C mm	L1 mm	L2 mm	Weight (steel) g/1 piece	Adapter Steel	Equivalent type Replacement (WITH ED SEAL**)	Adapter Stainless Steel	Equivalent type Replacement (WITH ED SEAL**)	PN (bar)
1/4	1/8	19	11.0	29	35	1/4X1/8PTR44MS	R11/4EDX1/8A3C	1/4X1/8PTR44MSS	R11/4EDX1/871	400
3/8	1/4	22	11.0	36	58	3/8X1/4PTR44MS	RI3/8EDX1/4A3C	3/8X1/4PTR44MSS	RI3/8EDX1/471	400
1/2	1/4	30	14.5	24	98	1/2X1/4PTR44MS	R11/2EDX1/4A3C	1/2X1/4PTR44MSS	R11/2EDX1/471	400
1/2	3/8	30	14.5	37	118	1/2X3/8PTR44MS	R11/2EDX3/8A3C	1/2X3/8PTR44MSS	R11/2EDX3/871	400
3/4	1/4	36	14.5	26	163	3/4X1/4PTR44MS	RI3/4EDX1/4A3C	3/4X1/4PTR44MSS	RI3/4EDX1/471	400
3/4	3/8	36	14.5	26	118	3/4X3/8PTR44MS	RI3/4EDX3/8A3C	3/4X3/8PTR44MSS	RI3/4EDX3/871	315
3/4	1/2	36	14.5	43	146	3/4X1/2PTR44MS	RI3/4EDX1/2A3C	3/4X1/2PTR44MSS	RI3/4EDX1/271	315
1	1/4	46	18.5	29	245	1X1/4PTR44MS	RI1EDX1/4A3C	1X1/4PTR44MSS	RI1EDX1/471	315
1	3/8	46	18.5	29	260	1X3/8PTR44MS	RI1EDX3/8A3C	1X3/8PTR44MSS	RI1EDX3/871	315
1	1/2	46	18.5	29	273	1X1/2PTR44MS	RI1EDX1/2A3C	1X1/2PTR44MSS	RI1EDX1/271	315
1	3/4	46	18.5	49	240	1X3/4PTR44MS	RI1EDX3/4A3C	1X3/4PTR44MSS	RI1EDX3/471	315

Parker Adapter are delivered with NBR elastomeric seals as standard. For more details on other seal materials see page N61.

Order codes shown are part of our current manufacturing programme.

Imperial and metric parts may vary in hexagon dimensions.

$$\frac{\text{PN (bar)}}{10} = \text{PN (MPa)}$$

Pressure ratings – PN shown, apply to the Steel and Stainless Steel versions of the product.

N

Adapters

PTR34M Thread reducer

Male BSPT thread (ISO 7) / Female BSPP thread (ISO 1179-1)

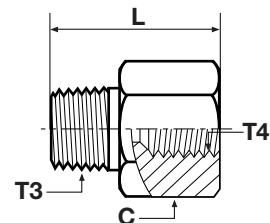

Thread BSPT T3	Thread BSPP T4	C mm	L mm	Weight (steel) g/1 piece	Adapter Steel	Adapter Stainless Steel	PN (bar)
1/4	1/8	14	28	16	1/4X1/8PTR34MS	1/4X1/8PTR34MSS	315
3/8	1/4	19	33	44	3/8X1/4PTR34MS	3/8X1/4PTR34MSS	315
1/2	1/4	22	39	71	1/2X1/4PTR34MS	1/2X1/4PTR34MSS	315
1/2	3/8	22	39	48	1/2X3/8PTR34MS	1/2X3/8PTR34MSS	315
3/4	1/4	27	39	108	3/4X1/4PTR34MS	3/4X1/4PTR34MSS	280
3/4	3/8	27	39	127	3/4X3/8PTR34MS	3/4X3/8PTR34MSS	280
3/4	1/2	27	42	94	3/4X1/2PTR34MS	3/4X1/2PTR34MSS	280
1	3/8	36	40	185	1X3/8PTR34MS	1X3/8PTR34MSS	210
1	1/2	36	48	224	1X1/2PTR34MS	1X1/2PTR34MSS	210
1	1/4	36	49	186	1X3/4PTR34MS	1X3/4PTR34MSS	210

Order codes shown are part of our current manufacturing programme.
Imperial and metric parts may vary in hexagon dimensions.

$$\frac{\text{PN (bar)}}{10} = \text{PN (MPa)}$$

Pressure ratings – PN shown, apply to Steel and Stainless Steel versions of the product.

FF33M Male nipple

Male BSPT thread (ISO 7)

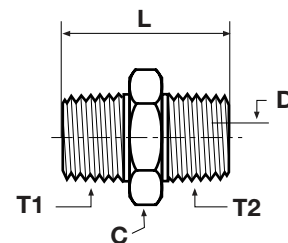

Thread BSPT T1	Thread BSPT T2	C mm	D mm	L mm	Weight (steel) g/1 piece	Adapter Steel	Adapter Stainless Steel	PN (bar)
1/8	1/8	11	5	27	12	1/8FF33MS	1/8FF33MSS	315
1/4	1/8	14	5	32	25	1/4X1/8FF33MS	1/4X1/8FF33MSS	315
1/4	1/4	14	7	37	25	1/4FF33MS	1/4FF33MSS	315
3/8	1/4	17	7	37	42	3/8X1/4FF33MS	3/8X1/4FF33MSS	315
3/8	3/8	17	10	37	30	3/8FF33MS	3/8FF33MSS	315
1/2	1/4	22	7	43	68	1/2X1/4FF33MS	1/2X1/4FF33MSS	315
1/2	3/8	22	10	43	67	1/2X3/8FF33MS	1/2X3/8FF33MSS	315
1/2	1/2	22	14	48	72	1/2FF33MS	1/2FF33MSS	315
3/4	1/2	27	14	50	123	3/4X1/2FF33MS	3/4X1/2FF33MSS	160
3/4	3/4	27	18	50	110	3/4FF33MS	3/4FF33MSS	160
1	3/4	36	18	55	215	1X3/4FF33MS	1X3/4FF33MSS	160

Order codes shown are part of our current manufacturing programme.
Imperial and metric parts may vary in hexagon dimensions.

$$\frac{\text{PN (bar)}}{10} = \text{PN (MPa)}$$

Pressure ratings – PN shown, apply to Steel and Stainless Steel versions of the product.

N

Adapters

HP3M Hexagon head plug

Male BSPT thread (ISO 7)

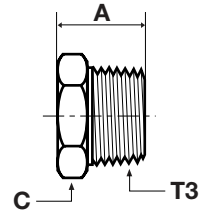

Thread BSPT T3	A mm	C mm	Weight (steel) g/1 piece	Adapter Steel	Adapter Stainless Steel	PN (bar)
1/8	14	11	9	1/8HP3MS	1/8HP3MSS	315
1/4	19	14	16	1/4HP3MS	1/4HP3MSS	315
3/8	20	17	35	3/8HP3MS	3/8HP3MSS	315
1/2	25	22	52	1/2HP3MS	1/2HP3MSS	315
3/4	27	27	85	3/4HP3MS	3/4HP3MSS	160
1	32	36	134	1HP3MS	1HP3MSS	160

Order codes shown are part of our current manufacturing programme.
Imperial and metric parts may vary in hexagon dimensions.

$$\frac{\text{PN (bar)}}{10} = \text{PN (MPa)}$$

Pressure ratings – PN shown, apply to Steel and Stainless Steel versions of the product.

0107 Swivel male stud

Male NPTF* thread (SAE J476) / NPSM Female swivel end (SAE J516)

SAE 140130

*Stainless Steel = NPT to prevent galling

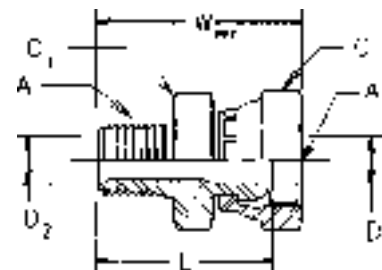

Thread NPTF A	Thread NPSM A1	C mm	C1 mm	D mm	D2 mm	L mm	W mm	Weight (steel) g/1 piece	Adapter Steel	Adapter Stainless Steel	PN (bar)
1/8-27	1/8-27	14	14	4	5	24	28	23	0107-2-2	0107-2-2-SS	350
1/8-27	1/4-18	18	16	6	5	27	32	33	0107-2-4	0107-2-4-SS	350
1/4-18	1/4-18	18	18	6	7	32	36	40	0107-4-4	0107-4-4-SS	350
1/4-18	3/8-18	22	21	9	7	32	37	57	0107-4-6	0107-4-6-SS	280
1/4-18	1/2-14	25	24	12	7	37	37	91	0107-4-8	0107-4-8-SS	245
3/8-18	1/4-18	18	18	6	10	33	38	48	0107-6-4	0107-6-4-SS	350
3/8-18	3/8-18	22	22	9	10	33	38	62	0107-6-6	0107-6-6-SS	280
3/8-18	1/2-14	25	24	12	10	37	44	97	0107-6-8	0107-6-8-SS	245
1/2-14	3/8-18	22	22	9	14	38	43	76	0107-8-6	0107-8-6-SS	280
1/2-14	1/2-14	25	25	12	14	41	49	109	0107-8-8	0107-8-8-SS	245
1/2-14	3/4-14	32	32	16	14	43	52	167	0107-8-12	0107-8-12-SS	140
3/4-14	1/2-14	25	29	12	18	41	49	122	0107-12-8	0107-12-8-SS	245
3/4-14	3/4-14	32	32	16	18	42	52	154	0107-12-12	0107-12-12-SS	140
3/4-14	1-11 1/2	38	38	21	18	46	55	247	0107-12-16	0107-12-16-SS	120
1-11 1/2	3/4-14	38	35	16	24	49	58	217	0107-16-12	0107-16-12-SS	140
1-11 1/2	1-11 1/2	38	38	21	24	51	60	238	0107-16-16	0107-16-16-SS	120
1-11 1/2	1 1/4-11 1/2	48	45	29	24	51	61	298	0107-16-20	0107-16-20-SS	120
1 1/4-11 1/2	1-11 1/2	38	48	21	32	53	63	356	0107-20-16	0107-20-16-SS	120
1 1/4-11 1/2	1 1/4-11 1/2	48	48	29	32	53	63	390	0107-20-20	0107-20-20-SS	120
1 1/2-11 1/2	1 1/2-11 1/2	54	54	35	38	56	66	498	0107-24-24	0107-24-24-SS	85
2-11 1/2	2-11 1/2	67	67	46	49	60	71	749	0107-32-32	0107-32-32-SS	75

Order codes shown are part of our current manufacturing programme.
Imperial and metric parts may vary in hexagon dimensions.

$$\frac{\text{PN (bar)}}{10} = \text{PN (MPa)}$$

Pressure ratings – PN shown, apply to Steel and Stainless Steel versions of the product.

Adapters

2107 Swivel male elbow

Male NPTF* thread (SAE J476) / NPSM Female swivel end (SAE J516)
SAE 140230

*Stainless Steel = NPT to prevent galling

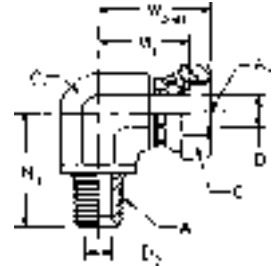

Thread NPTF A	Thread NPSM A1	C mm	C1 mm	D mm	D2 mm	M1 mm	N1 mm	W3 mm	Weight (steel) g/1 piece	Adapter Steel	Adapter Stainless Steel	PN (bar)
1/8-27	1/8-27	14	11	4	5	18	18	22	28	2107-2-2	2107-2-2-SS	350
1/4-18	1/4-18	18	14	6	7	22	28	27	55	2107-4-4	2107-4-4-SS	350
1/4-18	3/8-1/8	22	19	9	7	25	28	33	94	2107-4-6	2107-4-6-SS	280
3/8-18	1/4-18	18	19	6	10	25	31	30	88	2107-6-4	2107-6-4-SS	350
3/8-18	3/8-1/8	22	19	9	10	25	31	33	90	2107-6-6	2107-6-6-SS	280
3/8-18	1/2-14	25	19	12	10	26	31	34	107	2107-6-8	2107-6-8-SS	245
1/2-14	3/8-1/8	22	22	9	14	27	37	34	130	2107-8-6	2107-8-6-SS	280
1/2-14	1/2-14	25	22	12	14	28	37	36	139	2107-8-8	2107-8-8-SS	245
1/2-14	3/4-14	32	27	16	14	33	37	42	221	2107-8-12	2107-8-12-SS	140
3/4-14	3/8-1/8	22	27	9	18	30	40	38	227	2107-12-6	2107-12-6-SS	280
3/4-14	1/2-14	25	27	12	18	32	40	39	191	2107-12-8	2107-12-8-SS	245
3/4-14	3/4-14	32	27	16	18	33	40	42	225	2107-12-12	2107-12-12-SS	140
1-11 1/2	3/4-14	32	33	16	24	37	50	46	374	2107-16-12	2107-16-12-SS	140
1-11 1/2	1-11 1/2	38	33	21	24	39	50	49	361	2107-16-16	2107-16-16-SS	120
1 1/4-11 1/2	1 1/4-11 1/2	48	41	29	32	44	61	54	794	2107-20-20	2107-20-20-SS	120
1 1/2-11 1/2	1 1/2-11 1/2	54	48	35	38	48	67	59	782	2107-24-24	2107-24-24-SS	85
2-11 1/2	2-11 1/2	67	64	46	49	58	76	69	1910	2107-32-32	2107-32-32-SS	75

Order codes shown are part of our current manufacturing programme.
Imperial and metric parts may vary in hexagon dimensions.

$$\frac{\text{PN (bar)}}{10} = \text{PN (MPa)}$$

Pressure ratings – PN shown, apply to Steel and Stainless Steel versions of the product.

3107 Swivel male 45° elbow

Male NPTF* thread (SAE J476) / NPSM Female swivel end (SAE J516)

SAE 140330

*Stainless Steel = NPT to prevent galling

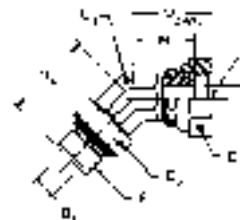

Thread NPTF A	Thread NPSM A1	C mm	C1 mm	D mm	D2 mm	M mm	N mm	W2 mm	Weight (steel) g/1 piece	Adapter Steel	Adapter Stainless Steel	PN (bar)
1/8-27	1/8-27	14	11	4	5	16	13	20	21	3107-2-2		350
1/4-18	1/4-18	18	14	6	7	19	22	23	44	3107-4-4	3107-4-4-SS	350
3/8-18	3/8-1/8	22	19	9	10	21	24	28	80	3107-6-6	3107-6-6-SS	280
1/2-14	3/8-1/8	22	22	9	14	21	30	28	110	3107-8-6	3107-8-6-SS	280
1/2-14	1/2-14	25	22	12	14	22	30	30	114	3107-8-8	3107-8-8-SS	245
1/2-14	3/4-14	32	27	16	14	22	31	31	144	3107-8-12	3107-8-12-SS	140
3/4-14	1/2-14	25	27	12	18	24	31	31	153	3107-12-8	3107-12-8-SS	245
3/4-14	3/4-14	32	27	16	18	26	31	35	172	3107-12-12	3107-12-12-SS	140
1-11 1/2	3/4-14	32	33	16	24	28	38	37	245	3107-16-12	3107-16-12-SS	140
1-11 1/2	1-11 1/2	38	33	21	24	29	38	39	368	3107-16-16	3107-16-16-SS	120
1 1/4-11 1/2	1 1/4-11 1/2	48	41	29	32	31	42	41	619	3107-20-20	3107-20-20-SS	120
1 1/2-11 1/2	1 1/2-11 1/2	54	48	35	38	34	45	45	719	3107-24-24	3107-24-24-SS	85
2-11 1/2	2-11 1/2	67	64	46	49	37	54	48	1372	3107-32-32	3107-32-32-SS	75

Order codes shown are part of our current manufacturing programme.
Imperial and metric parts may vary in hexagon dimensions.

$$\frac{\text{PN (bar)}}{10} = \text{PN (MPa)}$$

Pressure ratings – PN shown, apply to Steel and Stainless Steel versions of the product.

N

Adapters

0207 Female connector

Female NPTF* thread (SAE J476) / NPSM Female swivel end (SAE J516)

SAE 140131

*Stainless Steel = NPT to prevent galling

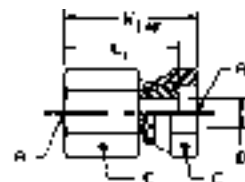

Thread NPTF A	Thread NPSM A1	C mm	C1 mm	D mm	L1 mm	W1 mm	Weight (steel) g/1 piece	Adapter Steel	Adapter Stainless Steel	PN (bar)
1/8-27	1/8-27	14	14	4	22	26	15	0207-2-2	0207-2-2-SS	350
1/4-18	1/4-18	18	18	6	32	36	44	0207-4-4	0207-4-4-SS	350
3/8-18	1/4-18	18	22	6	33	38	52	0207-6-4	0207-6-4-SS	350
3/8-18	3/8-18	22	22	9	33	38	81	0207-6-6	0207-6-6-SS	280
1/2-14	3/8-18	22	25	9	37	42	121	0207-8-6	0207-8-6-SS	280
1/2-14	1/2-14	25	25	12	38	46	119	0207-8-8	0207-8-8-SS	245
3/4-14	3/4-14	32	32	16	41	50	161	0207-12-12	0207-12-12-SS	140
1-11 1/2	1-11 1/2	38	38	21	51	60	162	0207-16-16	0207-16-16-SS	120
1 1/4-11 1/2	1 1/4-11 1/2	48	48	29	51	61	378	0207-20-20	0207-20-20-SS	120
1 1/2-11 1/2	1 1/2-11 1/2	54	54	35	51	62	446	0207-24-24	0207-24-24-SS	85
2-11 1/2	2-11 1/2	67	67	46	54	65	707	0207-32-32	0207-32-32-SS	75

Order codes shown are part of our current manufacturing programme.
Imperial and metric parts may vary in hexagon dimensions.

$$\frac{\text{PN (bar)}}{10} = \text{PN (MPa)}$$

Pressure ratings – PN shown, apply to Steel and Stainless Steel versions of the product.

2207 Female elbow

Female NPTF* thread (SAE J476) / NPSM Female swivel end (SAE J516)

SAE 140231

*Stainless Steel = NPT to prevent galling



Thread NPTF A	Thread NPSM A1	C mm	C1 mm	D mm	M1 mm	W3 mm	N3 mm	Weight (steel) g/1 piece	Adapter Steel	Adapter Stainless Steel	PN (bar)
1/8-27	1/8-27	14	14	4	20	24	17	37	2207-2-2	2207-2-2-SS	350
1/4-18	1/4-18	18	19	6	25	30	22	98	2207-4-4	2207-4-4-SS	350
3/8-18	3/8-1/8	22	22	9	27	32	26	152	2207-6-6	2207-6-6-SS	280
1/2-14	1/2-14	25	27	12	32	39	31	246	2207-8-8	2207-8-8-SS	245
3/4-14	3/4-14	32	33	16	37	46	35	313	2207-12-12	2207-12-12-SS	140
1-11 1/2	1-11 1/2	38	41	21	44	53	41	530	2207-16-16	2207-16-16-SS	120
1 1/4-11 1/2	1 1/4-11 1/2	48	48	29	47	56	43	1159	2207-20-20	2207-20-20-SS	120
1 1/2-11 1/2	1 1/2-11 1/2	54	64	35	61	72	53	1679	2207-24-24	2207-24-24-SS	85
2-11 1/2	2-11 1/2	67	71	47	65	76	61	2136	2207-32-32	2207-32-32-SS	75

Order codes shown are part of our current manufacturing programme.
Imperial and metric parts may vary in hexagon dimensions.

$$\frac{\text{PN (bar)}}{10} = \text{PN (MPa)}$$

Pressure ratings – PN shown, apply to Steel and Stainless Steel versions of the product.

N

Adapters

0507 Swivel male stud

Male UN/UNF thread O-ring (ISO 11926) / NPSM Female swivel end (SAE J516)
SAE 140157



Thread UN/UNF-2A B	Thread NPSM A1	C mm	C2 mm	D mm	D1 mm	L2 mm	W4 mm	Weight (steel) g/1 piece	Adapter Steel	PN (bar)
7/16-20	1/4-18	18	14	6	6	29	34	32	0507-4-4	350
9/16-18	1/4-18	18	18	6	6	30	34	45	0507-6-4	350
9/16-18	3/8-18	22	18	9	9	30	35	48	0507-6-6	280
9/16-18	1/2-14	25	19	8	8	33	40	76	0507-6-8	245
3/4-16	1/4-18	18	22	6	10	32	36	65	0507-8-4	350
3/4-16	3/8-18	22	22	9	9	32	37	69	0507-8-6	280
3/4-16	1/2-14	25	22	10	10	32	40	83	0507-8-8	245
3/4-16	3/4-14	32	25	16	10	37	46	137	0507-8-12	140
7/8-14	1/2-14	25	25	12	12	37	44	98	0507-10-8	245
1 1/16-12	1/2-14	25	32	12	12	40	48	157	0507-12-8	245
1 1/16-12	3/4-14	32	32	16	16	41	50	200	0507-12-12	140
1 5/16-12	1-11 1/2	38	38	21	21	45	54	317	0507-16-16	120
1 5/8-12	1 1/4-11 1/2	48	48	27	27	47	56	398	0507-20-20	120
1 7/8-12	1 1/2-11 1/2	54	54	33	33	50	61	498	0507-24-24	85
2 1/2-12	2-11 1/2	67	70	45	45	52	63	749	0507-32-32	75

Parker Adapter are delivered with NBR elastomeric seals as standard. For more details on other seal materials see page N61.

Order codes shown are part of our current manufacturing programme.

Imperial and metric parts may vary in hexagon dimensions.

$$\frac{\text{PN (bar)}}{10} = \text{PN (MPa)}$$

Pressure ratings – PN shown, apply to the Steel version of the product.

2507 Swivel male elbow

Male UN/UNF thread O-ring (ISO 11926) / NPSM Female swivel end (SAE J516)
SAE 140257

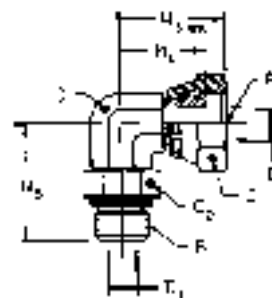

Thread UN/UNF-2A B	Thread NPSM A1	C mm	C1 mm	C2 mm	D mm	D1 mm	M1 mm	W3 mm	N5 mm	Weight (steel) g/1 piece	Adapter Steel	PN (bar)
7/16-20	1/4-18	18	11	14	6	4	20	25	26	42	2507-4-4	350
9/16-18	1/4-18	18	14	18	6	8	22	27	32	56	2507-6-4	350
9/16-18	3/8-18	22	14	18	9	8	23	28	32	56	2507-6-6	280
9/16-18	1/2-14	25	14	18	12	8	26	34	35	65	2507-6-8	245
3/4-16	3/8-18	22	19	22	9	10	25	30	37	119	2507-8-6	280
3/4-16	1/2-14	25	19	22	12	10	26	34	37	119	2507-8-8	245
3/4-16	3/4-14	32	19	22	16	10	33	42	41	174	2507-8-12	140
7/8-14	3/8-18	22	22	25	9	12	27	32	43	164	2507-10-6	280
7/8-14	1/2-14	25	22	25	12	12	28	36	43	178	2507-10-8	245
7/8-14	3/4-14	32	22	25	16	12	32	42	45	243	2507-10-12	140
1 1/16-12	1/2-14	25	27	32	12	16	31	38	49	193	2507-12-8	245
1 1/16-12	3/4-14	32	27	32	16	16	33	42	49	283	2507-12-12	140
1 5/16-12	1-11 1/2	38	33	38	21	21	39	49	52	525	2507-16-16	120
1 5/8-12	1 1/4-11 1/2	48	41	48	29	27	45	55	57	530	2507-20-20	120
1 7/8-12	1 1/2-11 1/2	54	48	54	35	33	48	59	61	600	2507-24-24	85

Parker Adapter are delivered with NBR elastomeric seals as standard. For more details on other seal materials see page N61.

Order codes shown are part of our current manufacturing programme.

Imperial and metric parts may vary in hexagon dimensions.

$$\frac{\text{PN (bar)}}{10} = \text{PN (MPa)}$$

Pressure ratings – PN shown, apply to the Steel version of the product.

N

Adapters

3507 Swivel male 45° elbow

Male UN/UNF thread O-ring (ISO 11926) / NPSM Female swivel end (SAE J516)
SAE 140357

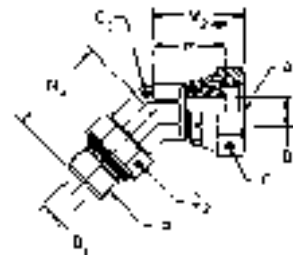

Thread UN/UNF-2A B	Thread NPSM A1	C mm	C1 mm	C2 mm	D mm	D1 mm	M mm	W2 mm	N4 mm	Weight (steel) g/1 piece	Adapter Steel	PN (bar)
7/16-20	1/4-18	18	11	14	6	4	16	20	27	41	3507-4-4	350
9/16-18	3/8-18	22	14	18	9	8	21	26	29	62	3507-6-6	280
3/4-16	3/8-18	22	19	22	9	10	21	26	33	106	3507-8-6	280
3/4-16	1/2-14	25	19	22	12	10	23	30	33	141	3507-8-8	245
3/4-16	3/4-14	32	19	22	16	10	26	35	36	226	3507-8-12	140
7/8-14	1/2-14	25	22	25	12	12	22	30	39	154	3507-10-8	245
1 1/16-12	3/4-14	32	27	32	16	16	26	35	44	208	3507-12-12	140
1 5/16-12	1-11 1/2	38	33	38	21	21	29	39	47	408	3507-16-16	120

Parker Adapter are delivered with NBR elastomeric seals as standard. For more details on other seal materials see page N61.
Order codes shown are part of our current manufacturing programme.
Imperial and metric parts may vary in hexagon dimensions.

$$\frac{\text{PN (bar)}}{10} = \text{PN (MPa)}$$

Pressure ratings – PN shown, apply to the Steel version of the product.

F3MT4 Male stud connector

JIS BSPP 30° flare end (JIS B8363) / Male BSPT thread (ISO 7)

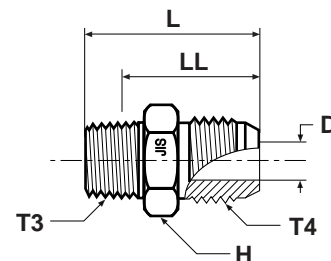

Thread BSPP T4	Thread BSPT T3	D mm	H mm	L mm	LL mm	Weight (steel) g/1 piece	Adapter Steel	Adapter Stainless Steel	PN (bar)
1/4	1/4	5	19	37	29	41	4F3T4S	4F3MT4SS	315
1/4	3/8	5	22	38	30	61	4-6F3T4S	4-6F3MT4SS	315
3/8	1/4	7	22	40	32	57	6-4F3T4S	6-4F3MT4SS	315
3/8	3/8	7	22	40	32	66	6F3T4S	6F3MT4SS	315
1/2	3/8	10	27	43	35	88	8-6F3T4S	8-6F3MT4SS	315
1/2	1/2	11	27	48	37	105	8F3T4S	8F3MT4SS	315
3/4	3/4	16	37	53	41	334	12F3T4S	12F3MT4SS	160
1	1	21	41	58	45	268	16F3T4S	16F3MT4SS	120

Order codes shown are part of our current manufacturing programme.
Imperial and metric parts may vary in hexagon dimensions.

$$\frac{\text{PN (bar)}}{10} = \text{PN (MPa)}$$

Pressure ratings – PN shown, apply to Steel and Stainless Steel versions of the product.

Adapters

C3T4 Male elbow

JIS BSPP 30° flare end (JIS B8363) / Male BSPT thread (ISO 7)

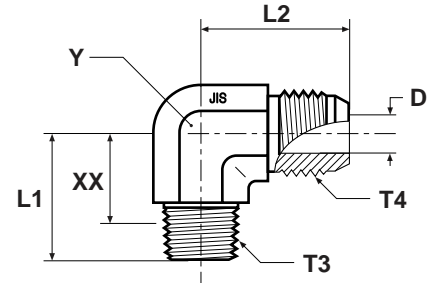

Thread BSPP T4	Thread BSPT T3	D mm	L1 mm	L2 mm	XX mm	Y mm	Weight (steel) g/1 piece	Adapter Steel	PN (bar)
1/4	1/4	5	25	25	18	14	41	4C3T4S	315
3/8	3/8	7	30	29	23	19	74	6C3T4S	315
1/2	1/2	11	36	34	26	22	131	8C3T4S	200
3/4	3/4	16	43	38	29	27	146	12C3T4S	160
1	1	21	50	44	37	33	398	16C3T4S	120

V3T4 Male 45° elbow

JIS BSPP 30° Flare end (JIS B8363) / Male BSPT thread (ISO 7)

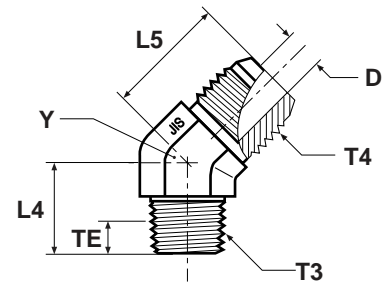

Thread BSPP T4	Thread BSPT T3	D mm	L4 mm	L5 mm	TE mm	Y mm	Weight (steel) g/1 piece	Adapter Steel	PN (bar)
1/4	1/4	5	19	22	8	14	33	4V3T4S	315
3/8	3/8	7	22	25	8	19	64	6V3T4S	315
1/2	1/2	11	27	28	11	22	112	8V3T4S	200
3/4	3/4	16	30	32	12	27	162	12V3T4S	160
1	1	21	35	32	14	33	256	16V3T4S	120

Order codes shown are part of our current manufacturing programme.
Imperial and metric parts may vary in hexagon dimensions.

$$\frac{\text{PN (bar)}}{10} = \text{PN (MPa)}$$

Pressure ratings – PN shown, apply to the Steel version of the product.

HMP4 Union

JIS BSPP 60° cone end (JIS B8363)

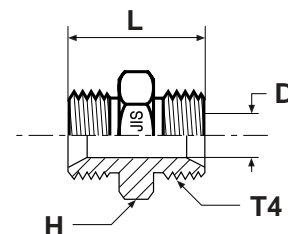

Thread BSPP T4	D mm	H mm	L mm	Weight (steel) g/1 piece	Adapter Steel	Adapter Stainless Steel	PN (bar)
1/4	5	19	34	40	4HP4S	4HMP4SS	350
3/8	7	22	38	91	6HP4S	6HMP4SS	350
1/2	11	27	46	159	8HP4S	8HMP4SS	200
3/4	16	37	52	186	12HP4S	12HMP4SS	200
1	21	41	58	290	16HP4S	16HMP4SS	120

HP46 Swivel female union

JIS BSPP 60° Cone swivel female end (JIS B8363)

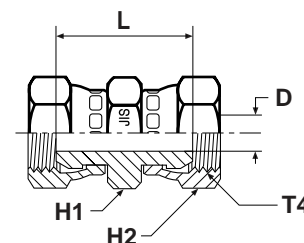

Thread BSPP T4	D mm	H1 mm	H2 mm	L mm	Weight (steel) g/1 piece	Adapter Steel	PN (bar)
1/4	5	19	19	31	33	4HP46S	350
3/8	7	22	22	35	49	6HP46S	350
1/2	11	27	27	38	77	8HP46S	200
3/4	16	37	37	40	114	12HP46S	200
1	21	41	41	46	180	16HP46S	120

Order codes shown are part of our current manufacturing programme.
Imperial and metric parts may vary in hexagon dimensions.

$$\frac{\text{PN (bar)}}{10} = \text{PN (MPa)}$$

Pressure ratings – PN shown, apply to the Steel version of the product.

Adapters

F3MP4 Male stud connector

JIS BSPP 60° Cone end (JIS B8363) / Male BSPT thread (ISO 7)

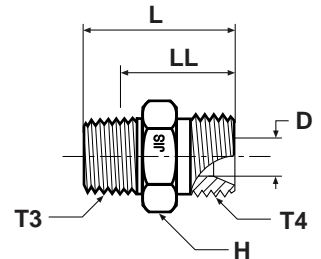

Thread BSPP T4	Thread BSPT T3	D mm	H mm	L mm	LL mm	Weight (steel) g/1 piece	Adapter Steel	Adapter Stainless Steel	PN (bar)
1/4	1/4	5	19	37	28	47	4F3P4S	4F3MP4SS	315
3/8	3/8	7	22	38	30	67	6F3P4S	6F3MP4SS	315
1/2	1/2	11	27	46	35	109	8F3P4S	8F3MP4SS	200
3/4	3/4	16	37	52	40	195	12F3P4S	12F3MP4SS	160
1	1	21	41	58	44	292	16F3P4S	16F3MP4SS	120

C3P4 Male 45° elbow

JIS BSPP 60° cone end (JIS B8363) / Male BSPT thread (ISO 7)

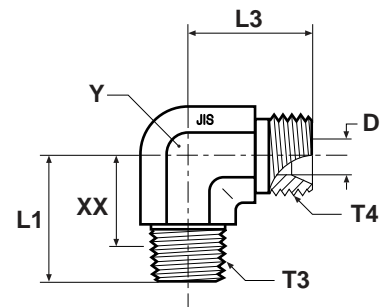

Thread BSPP T4	Thread BSPT T3	D mm	L1 mm	L3 mm	XX mm	Y mm	Weight (steel) g/1 piece	Adapter Steel	PN (bar)
1/4	1/4	5	25	24	18	14	49	4C3P4S	315
3/8	3/8	7	30	29	23	19	97	6C3P4S	315
1/2	1/2	11	36	33	26	22	147	8C3P4S	200
3/4	3/4	16	43	40	29	27	206	12C3P4S	160
1	1	21	50	44	37	33	434	16C3P4S	120

Order codes shown are part of our current manufacturing programme.
Imperial and metric parts may vary in hexagon dimensions.

$$\frac{\text{PN (bar)}}{10} = \text{PN (MPa)}$$

Pressure ratings – PN shown, apply to Steel and Stainless Steel versions of the product.

V3P4 Male 45° elbow

JIS BSPP 60° Cone end (JIS B8363) / Male BSPT thread (ISO 7)

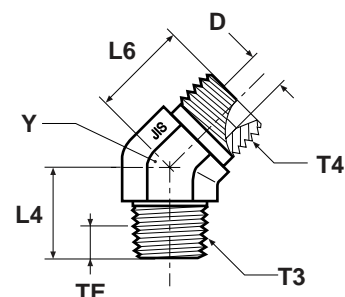

Thread BSPP T4	Thread BSPT T3	D mm	L4 mm	L6 mm	TE mm	Y mm	Weight (steel) g/1 piece	Adapter Steel	PN (bar)
1/4	1/4	5	19	21	8	14	36	4V3P4S	350
3/8	3/8	7	22	23	8	19	65	6V3P4S	350
1/2	1/2	11	27	27	11	22	122	8V3P4S	200
3/4	3/4	16	30	30	12	27	159	12V3P4S	200
1	1	21	35	33	14	33	412	16V3P4S	120

F63MP4 Swivel male stud

JIS BSPP 60° Cone swivel female end (JIS B8363) / Male BSPT thread (ISO 7)

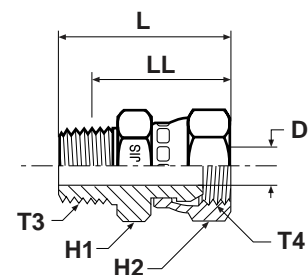

Thread BSPT T3	Thread BSPP T4	D mm	H1 mm	H2 mm	L mm	LL mm	Weight (steel) g/1 piece	Adapter Steel	Adapter Stainless Steel	PN (bar)
1/4	1/4	5	19	19	33	24	41	4F63P4S	4F63MP4SS	315
3/8	3/8	7	22	22	37	28	70	6F63P4S	6F63MP4SS	315
1/2	1/2	11	27	27	42	31	122	8F63P4S	8F63MP4SS	200
3/4	3/4	16	37	37	47	35	254	12F63P4S	12F63MP4SS	160
1	1	21	41	41	52	38	367	16F63P4S	16F63MP4SS	120

Order codes shown are part of our current manufacturing programme.
Imperial and metric parts may vary in hexagon dimensions.

$$\frac{\text{PN (bar)}}{10} = \text{PN (MPa)}$$

Pressure ratings – PN shown, apply to Steel and Stainless Steel versions of the product.

Adapters

G63P4 Female swivel connector

JIS BSPP 30° Flare swivel female end (JIS B8363) / Female BSPT thread (ISO 7)

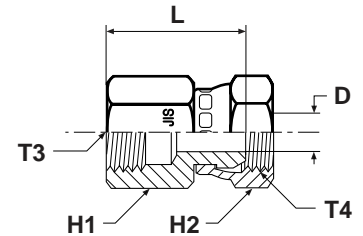

Thread BSPT T3	Thread BSPP T4	D mm	H1 mm	H2 mm	L mm	Weight (steel) g/1 piece	Adapter Steel	PN (bar)
1/4	1/4	5	19	19	30	36	4G63P4S	315
3/8	3/8	7	22	22	33	49	6G63P4S	315
1/2	1/2	11	27	27	36	73	8G63P4S	200
3/4	3/4	16	37	37	38	163	12G63P4S	160
1	1	21	41	41	46	195	16G63P4S	120

G3P4 Female stud connector

JIS BSPP 30° Flare end (JIS B8363) / Female BSPT thread (ISO 7)

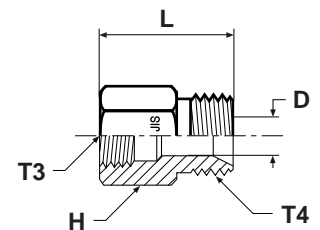

Thread BSPT T3	Thread BSPP T4	D mm	H mm	L mm	Weight (steel) g/1 piece	Adapter Steel	PN (bar)
1/4	1/4	5	19	31	40	4G3P4S	315
3/8	3/8	7	22	34	55	6G3P4S	315
1/2	1/2	11	27	40	141	8G3P4S	200
3/4	3/4	16	37	44	159	12G3P4S	160
1	1	21	41	49	225	16G3P4S	120

Order codes shown are part of our current manufacturing programme.
Imperial and metric parts may vary in hexagon dimensions.

$$\frac{\text{PN (bar)}}{10} = \text{PN (MPa)}$$

Pressure ratings – PN shown, apply to the Steel version of the product.

Spare parts guide – Adapters retaining rings and seals

BSP Male threads – ISO 1179

BSP Thread	ED Seal Order code		O-ring Order code*		O-Ring ID section mm	Retainer ring Order code Steel	Retainer ring Order code Stainless Steel
	NBR	FKM	NBR	FKM			
1/8	ED10X1X	ED10X1VITX	6-002-N552-9	6-002-V894-9	8.00 2.00	8207-1/8	8207SS1/8
1/4	ED14X1.5X	ED14X1.5VITX	2-111-N552-9	2-111-V894-9	10.77 2.62	8207-1/4	8207SS1/4A
3/8	ED3/8X	ED3/8VITX	2-113-N552-9	2-113-V894-9	13.94 2.62	8207-3/8	8207SS3/8A
1/2	ED1/2X	ED1/2VITX	5-256-N552-9	5-256-V894-9	17.96 2.62	8207-1/2	8207SS1/2
3/4	ED26X1.5X	ED26X1.5VITX	2-119-N552-9	2-119-V894-9	23.47 2.62	8207-3/4	8207SS3/4
1	ED33X2X	ED33X2VITX	2-217-N552-9	2-217-V894-9	29.74 3.53	8207-1	8207SS1A
1 1/4	ED42X2X	ED42X2VITX	2-222-N552-9	2-222-V894-9	37.69 3.53	8207-1-1/4	8207SS1 1/4
1 1/2	ED48X2X	ED48X2VITX	2-224-N552-9	2-224-V894-9	44.04 3.53	8207-1-1/2	8207SS1 1/2

Typical fittings using these parts: PTR44M / RI-ED / F4OHG5 etc.

* Must be used with correct retainer ring

Metric male threads – ISO 9974

Metric Thread	ED Seal Order code		O-ring Order code*		O-Ring ID section mm	Retainer ring Order code Steel	Retainer ring Order code Stainless Steel
	NBR	FKM	NBR	FKM			
M10x1	ED10X1X	ED10X1VITX	6-074-N552-9	6-074-V894-9	8.00 1.50	M10RR	RRM10X1SS
M12x1.5	ED12X1.5X	ED12X1.5VITX	2-012-N552-9	2-012-V894-9	9.25 1.78	M12RR	RRM12X1.5SS
M14x1.5	ED14X1.5X	ED14X1.5VITX	2-013-N552-9	2-013-V894-9	10.82 1.78	M14RR	RRM14X1.5SS
M16x1.5	ED16X1.5X	ED16X1.5VITX	3-907-N552-9	3-907-V894-9	13.46 2.08	M16RR	RRM16X1.5SS
M18x1.5	ED18X1.5X	ED18X1.5VITX	2-114-N552-9	2-114-V894-9	15.54 2.62	M18RR	RRM18X1.5SS
M22x2	ED22X1.5X	ED22X1.5VITX	2-018-N552-9	2-018-V894-9	18.77 1.78	M22RR	RRM22X1.5SS
M27x2	ED26X1.5X**	ED26X1.5VITX	2-119-N552-9	2-119-V894-9	23.47 2.62	M27RR	RRM27X2SS
M33x2	ED33X2X	ED33X2VITX	2-122-N552-9	2-122-V894-9	28.24 2.62	M33RR	RRM33X2SS
M42x2	ED42X2X	ED42X2VITX	2-128-N552-9	2-128-V894-9	37.77 2.62	M42RR	RRM42X2SS
M48x2	ED48X2X	ED48X2VITX	2-132-N552-9	2-132-V894-9	44.12 2.62	M48RR	RRM48X2SS

Typical fittings using these parts: F8OHG5 / VSTI MED etc..

* Must be used with correct retainer ring

** Same seal used for M26X1.5 and M27X2 Threads

UN / UNF male threads – ISO 11926

UN / UNF Thread	Dash size	O-ring Order code*		O-Ring ID x section mm	
		NBR	FKM		
5/16-24	2	3-902-N552-9	3-902-V894-9	6.07	1.63
3/8-24	3	3-903-N552-9	3-903-V894-9	7.65	1.63
7/16-20	4	3-904-N552-9	3-904-V894-9	8.92	1.83
1/2-20	5	3-905-N552-9	3-905-V894-9	10.52	1.83
9/16-8	6	3-906-N552-9	3-906-V894-9	11.89	1.98
3/4-16	8	3-908-N552-9	3-908-V894-9	16.36	2.21
7/8-14	10	3-910-N552-9	3-910-V894-9	19.18	2.46
1 1/16-12	12	3-912-N552-9	3-912-V894-9	23.47	2.95
1 3/16-12	14	3-914-N552-9	3-914-V894-9	26.59	2.95
1 5/16-12	16	3-916-N552-9	3-916-V894-9	29.74	2.95
1 5/8-12	20	3-920-N552-9	3-920-V894-9	37.47	3.00
1 7/8-12	24	3-924-N552-9	3-924-V894-9	43.69	3.00
2 1/2-12	32	3-932-N552-9	3-932-V894-9	59.36	3.00

Typical fittings using these parts: F5OG / P5ON / F5OHAO etc..

Other seal compounds available on request for alternative applications

Metric male threads – ISO 6149

Metric Thread		O-ring Order code*		O-Ring ID section mm	
		NBR	FKM		
M10	1	6-345-N552-9	6-345-V894-9	8.20	1.50
M12	1.5	6-346-N552-9	6-346-V894-9	9.40	2.10
M14	1.5	6-347-N552-9	6-347-V894-9	11.40	2.10
M16	1.5	6-348-N552-9	6-348-V894-9	13.40	2.10
M18	1.5	6-349-N552-9	6-349-V894-9	15.40	2.10
M22	1.5	6-350-N552-9	6-350-V894-9	19.40	2.10
M27	2	6-351-N552-9	6-351-V894-9	23.70	2.80
M33	2	6-352-N552-9	6-352-V894-9	29.70	2.80
M42	2	6-353-N552-9	6-353-V894-9	38.70	2.80
M48	2	6-354-N552-9	6-354-V894-9	46.70	2.80

Typical fittings using these parts: VSTI-OR etc.



ED[®] Ermeto Original *Valves*



Visual index Non return valves

RHD / p. O11

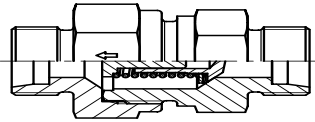

EO 24° cone end / EO 24° cone end

RHV-R-ED / p. O12

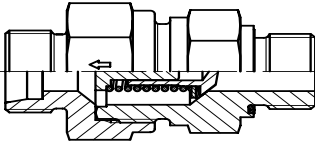

EO 24° cone end /
Male BSPP thread – ED-seal (ISO 1179)

RHZ-R-ED / p. O13

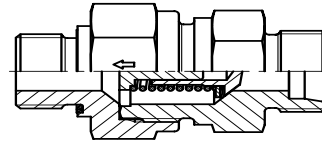

Male BSPP thread – ED-seal (ISO 1179) /
EO 24° cone end

RHV-M-ED / p. O14

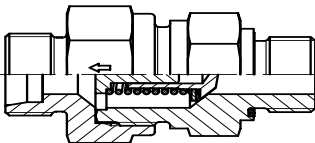

EO 24° cone end /
Male metric thread – ED-seal (ISO 9974)

RHZ-M-ED / p. O15

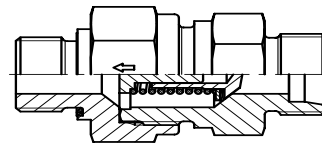

Male metric thread – ED-seal (ISO 9974) /
EO 24° cone end

RHDI / p. O16

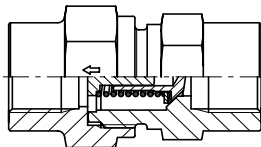

Female BSPP thread (ISO 1179-1) /
Female BSPP thread (ISO 1179-1)

RVP / p. O17

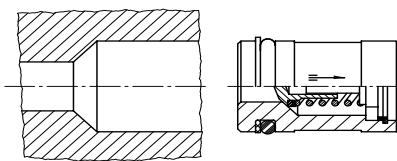

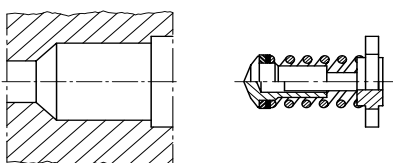

Non return valve cartridge

I-TL / p. O18

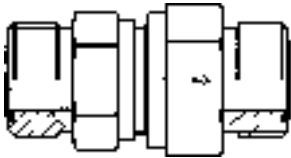
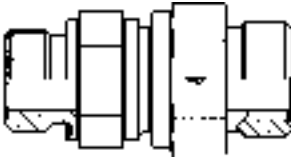

Internal parts of non return valve

Visual index Non return valves with O-Lok® connections

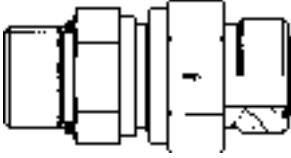
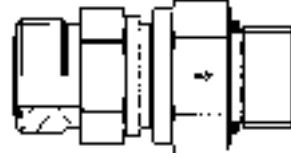
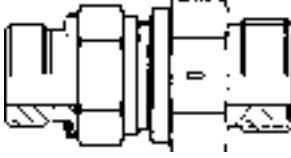
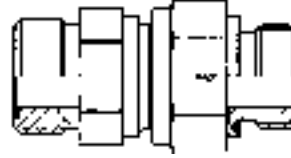

<p>RHDMLOS / p. O20</p>  <p>O-Lok® ORFS end / O-Lok® ORFS end</p>	
<p>RHV42EDMLOS / p. O21</p>  <p>Male BSPP thread – ED-seal (ISO 1179) / O-Lok® ORFS end</p>	<p>RHZ42EDMLOS / p. O22</p>  <p>O-Lok® ORFS end / Male BSPP thread – ED-seal (ISO 1179)</p>
<p>RHV50MLOS / p. O23</p>  <p>Male UN/UNF thread – O-ring (ISO 11926) / O-Lok® ORFS end</p>	<p>RHZ50MLOS / p. O24</p>  <p>O-Lok® ORFS end / Male UN/UNF thread – O-ring (ISO 11926)</p>
<p>RHV82EDMLOS / p. O25</p>  <p>Male metric thread – ED-seal (ISO 9974) / O-Lok® ORFS end</p>	<p>RHZ82EDMLOS / p. O26</p>  <p>O-Lok® ORFS end / Male metric thread – ED-seal (ISO 9974)</p>

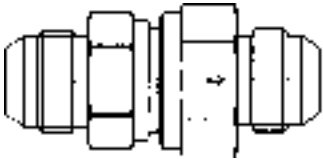
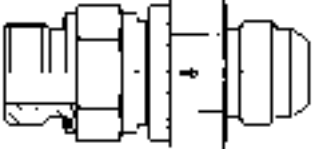
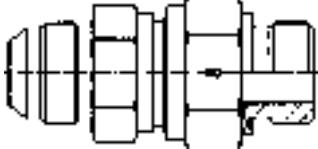
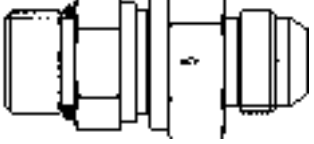
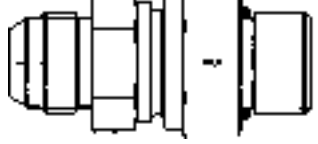
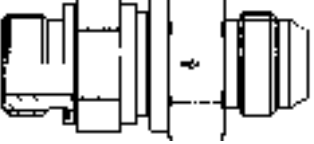
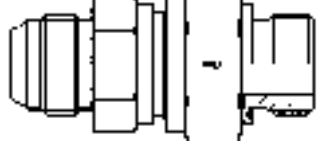

Visual index Non return valves with Triple-Lok® connections

<p>RHDMTXS / p. O27</p>  <p>Triple-Lok® 37° flare end / Triple-Lok® 37° flare end</p>	
<p>RHV42EDMXS / p. O28</p>  <p>Male BSPP thread – ED-seal (ISO 1179) / Triple-Lok® 37° flare end</p>	<p>RHZ42EDMXS / p. O29</p>  <p>Triple-Lok® 37° flare end / Male BSPP thread – ED-seal (ISO 1179)</p>
<p>RHV50MXS / p. O30</p>  <p>Male UN/UNF thread – O-ring (ISO 11926) / Triple-Lok® 37° flare end</p>	<p>RHZ50MXS / p. O31</p>  <p>Triple-Lok® 37° flare end / Male UN/UNF thread – O-ring (ISO 11926)</p>
<p>RHV82EDMXS / p. O32</p>  <p>Male metric thread – ED-seal (ISO 9974) / Triple-Lok® 37° flare end</p>	<p>RHZ82EDMXS / p. O33</p>  <p>Triple-Lok® 37° flare end / Male metric thread – ED-seal (ISO 9974)</p>

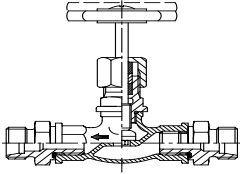
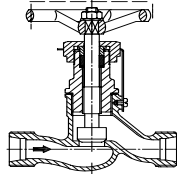
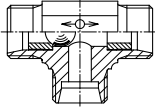
Visual index shut off valves and ball valves

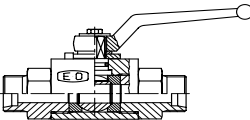
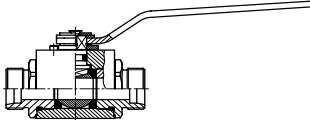
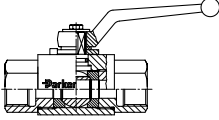
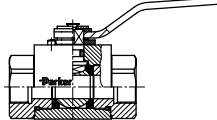
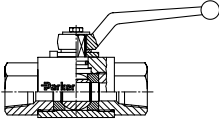
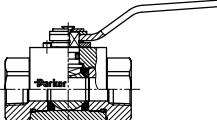
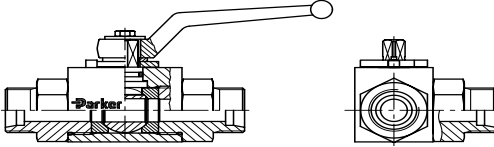
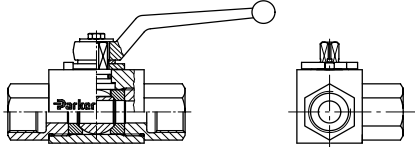
 <p>DV p. O34</p> <p>EO 24° cone end / EO 24° cone end</p>	 <p>LD p. O35</p> <p>EO 24° cone end / EO 24° cone end</p>
 <p>WV p. O36</p> <p>EO 24° cone end / EO 24° cone end / EO 24° cone end</p>	 <p>ELA/ELAE p. O46</p> <p>Air-bleed valves</p>
 <p>KH (S) p. O37</p> <p>EO 24° cone end / EO 24° cone end</p>	 <p>KH (71) p. O38</p> <p>EO 24° cone end / EO 24° cone end</p>
 <p>KH-BSPP (S) p. O39</p> <p>Female BSPP thread (ISO 1179-1) / Female BSPP thread (ISO 1179-1)</p>	 <p>KH-BSPP (71) p. O40</p> <p>Female BSPP thread (ISO 1179-1) / Female BSPP thread (ISO 1179-1)</p>
 <p>KH-NPT (S) p. O41</p> <p>Female NPT thread (SAE 476) / Female NPT thread (SAE 476)</p>	 <p>KH-NPT (71) p. O42</p> <p>Female NPT thread (SAE 476) / Female NPT thread (SAE 476)</p>
 <p>KH 3/2 (S) p. O43</p> <p>EO 24° cone end / EO 24° cone end / EO 24° cone end</p>	
 <p>KH 3/2-BSPP(S) p. O44</p> <p>Female BSPP thread (ISO 1179-1) / Female BSPP thread (ISO 1179-1) / Female BSPP thread (ISO 1179-1)</p>	



Range of non return valves and alternating valves

Non-return valves with nominal pressure ratings up to PN 420 bar:

- with tube connection both ends: RHD
- with tube connection to male stud: RHV/RHZ
- with female thread both ends: RHD1
- valve cartridges: RVP
- valve internal parts: I-TL
- leakage rate hydraulic testing under test pressure: 1 drop per minute

Alternating valves:

- for nominal pressure ratings up to PN 160: WV
- leakage rate hydraulic testing under test pressure: 20 drops per minute

Hand-operated Shut-off valves:

- for low pressure ratings up to PN 10 bar: DV
- for medium pressure ratings up to PN 40 bar: LD

Design:

1. For materials, permissible working pressures, temperatures, flow medium torques for male studs etc. see relevant pages of the catalogue.
2. Tube connection ends must be assembled according to the Parker EO/EO 2 assembly instructions. The valve bodies must be held rigidly during assembly of the tube connection ends.
3. Test pressures for non return valves: PN in conformance with O.D. information see chapter C.
4. Pressure drop values please see p. C12 and diagrams.

Caution!

Please note the admissible pressure ratings for the EO-tube ends.

Range of hand-operated shut off valves and quarter turn ball valves

Quarter turn Hand-operated ball valves:

- for high pressure ratings up to PN 500 bar: KH
- leakage rate hydraulic testing under test pressure: 0 drops per minute

The pressure specification PN for hand-operated shut-off valves and quarter turn ball valves applies to the design factor 1,5 (according DIN 3230 T5 and ISO 5208).

Steel

Materials:

Body made of steel, coating DIN 50938-FE//A/T4, ball of hard chrome plated carbon steel, stem of zinc plated steel.

Seals:

Ball seat of POM (e. g. Delrin), stem seal of NBR (e. g. Perbunan).

Applications:

Suitable for petroleum-based hydraulic fluid, lubricants and fuel oil.

For applications suitable up to 100 bar.

Temperature range:

–10 up to +100 °C.

Stainless Steel

Materials:

Body made of stainless steel, ball of stainless steel, stem and connectors of stainless steel.

Seals:

Ball seat of POM (e. g. Delrin), stem seal of NBR (e. g. Perbunan), DOZ from function nut FPM (e. g. Viton).

Applications:

Suitable for petroleum-based hydraulic fluid, lubricants and fuel oil.

For applications suitable up to 100 bar.

Temperature range:

–30 up to +100 °C.

Notes:

To assess the suitability of valves for specific applications, please advise us of the exact specification of the medium to be used, max. working pressure incl. pressure peaks, temperature and frequency of valve operations. If water is used, indicate type of water or additives, if any.

RHD/V/Z non return valve

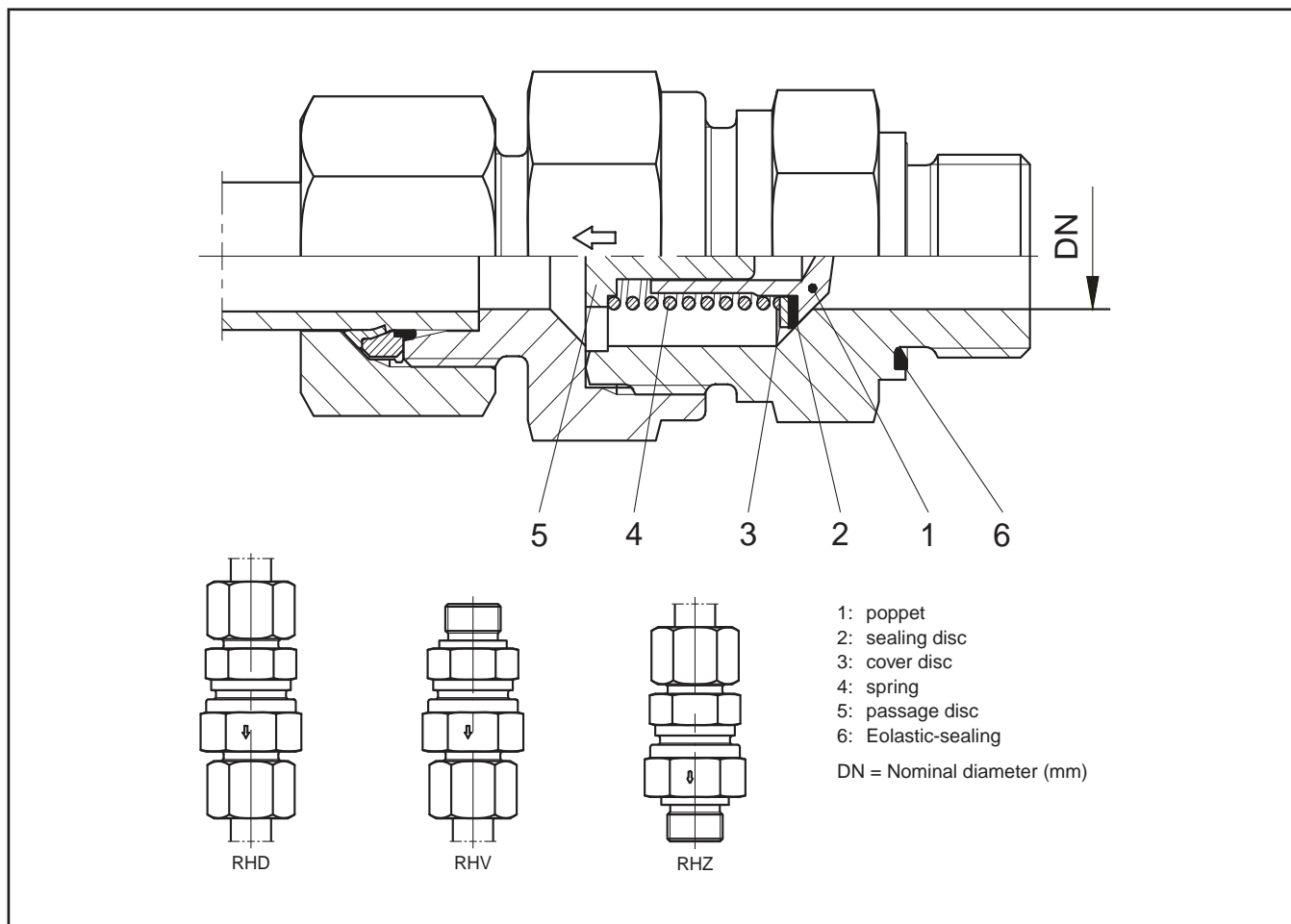

Characteristics:

Poppet check valve with a 90° valve seat with an elastomere sealing disc. Poppet stop for controlled valve opening. Damped opening action to minimize shock and noise. No reduction of cross section. Maximum flow velocity not more than 8 m/sec (for higher flow velocities special tests are required). Sealing of male stud thread by Eolastic soft seal with types RHV and RHZ.

Opening pressure:

Standard 1 bar (on request also 0.2, 0.5, 2, 3, 4, 5 and 6 bar are available; please specify on order). For working pressure see appropriate tables. Cracking pressure tolerance: $\pm 20\%$.

Material:

- Steel zinc-plated (A3C) or (CF chromium⁶-free), seals in NBR (e.g. Perbunan*), or (e.g. Viton*) on request.

- Stainless steel valves have FKM (e.g. Viton*) as standard.
(Up to 3 bar cracking pressure)
- Brass-valves (CuZn35Ni2 2.0540) with internals (1.4571) available on request.
(Up to 3 bar cracking pressure)

Assembly:

See assembly instructions for EO/EO 2 connections. Non-return valves are all packaged against contamination.

Media:

Hydraulic oil, low flammability hydraulic fluids (except for types HFC: for HFD types; FKM seals are necessary). Please indicate on order if used with compressed air. Not suitable for steam, combustible/explosive gases, or oxygen. For water applications, please consult Parker with details of water and any additives.

*Perbunan and Viton are registered trademarks of Bayer and Dupont.

In all diagrams is the peak value of the flow rate in l/min. relating to the maximum permissible flow velocity of 8 m/sec.

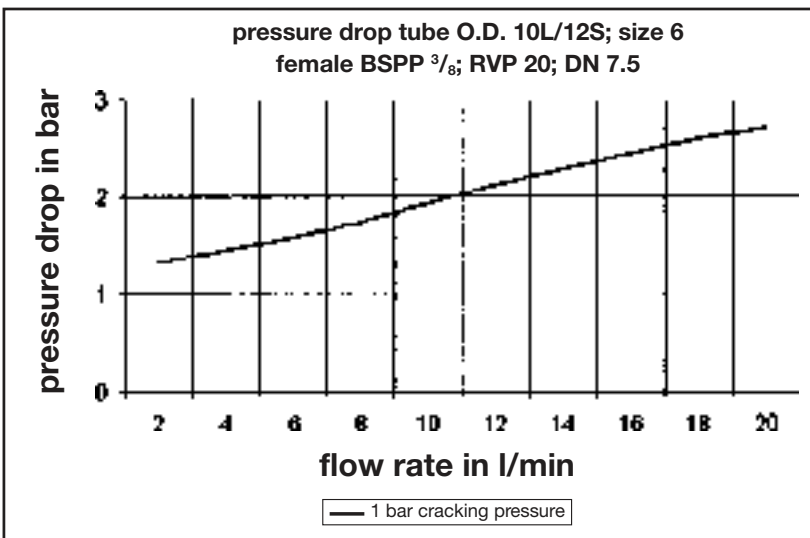
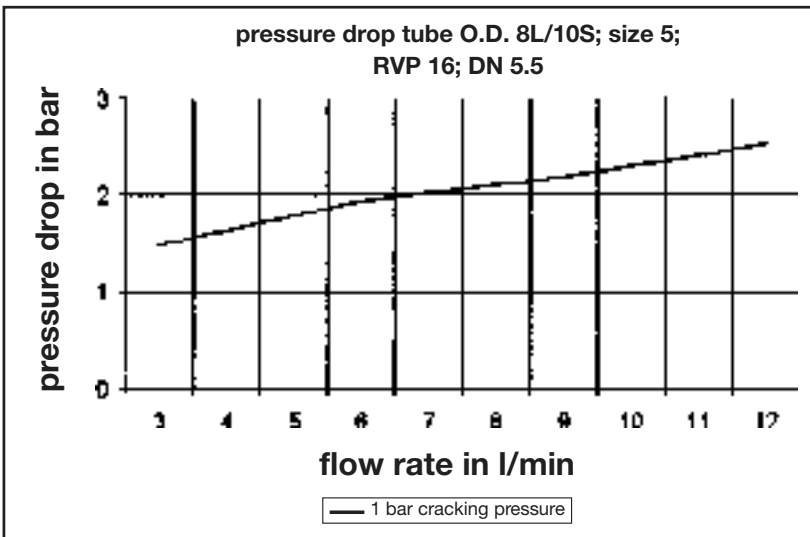
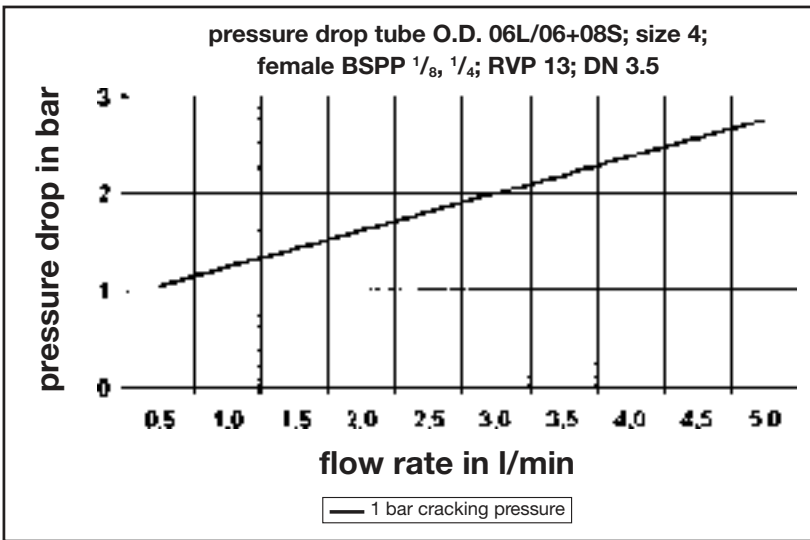

In all diagrams is the peak value of the flow rate in l/min. relating to the maximum permissible flow velocity of 8 m/sec.

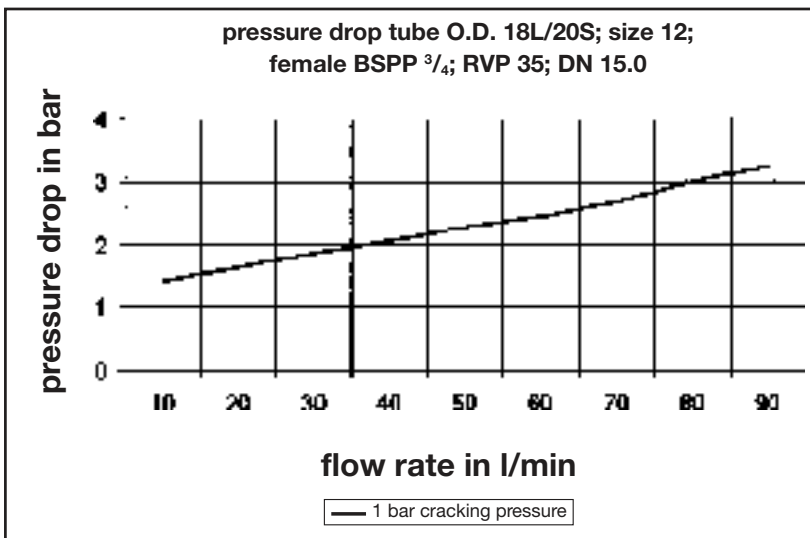
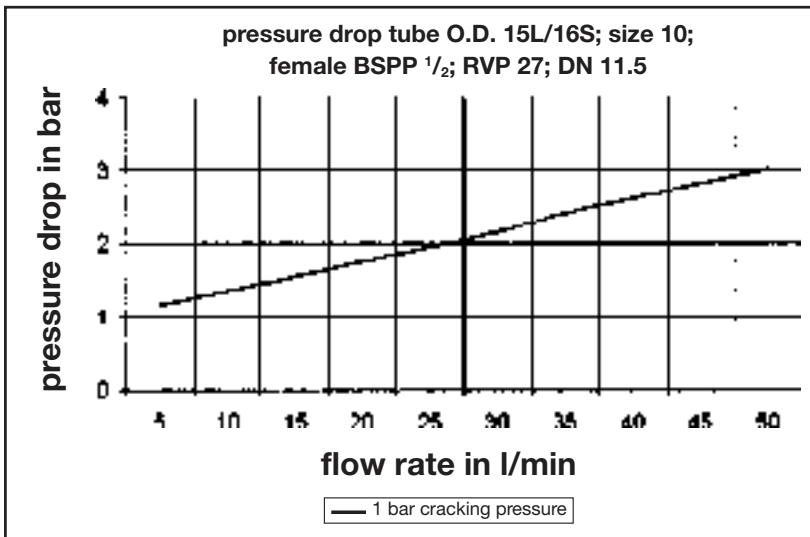
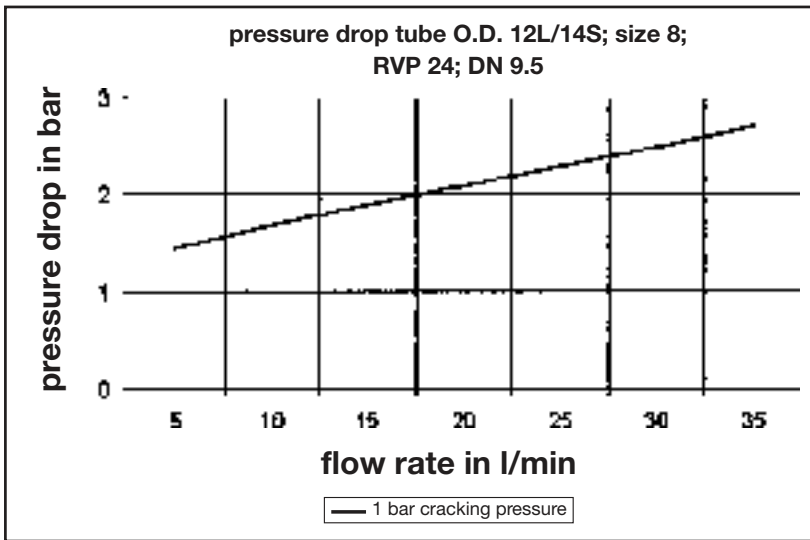

In all diagrams is the peak value of the flow rate in l/min. relating to the maximum permissible flow velocity of 8 m/sec.

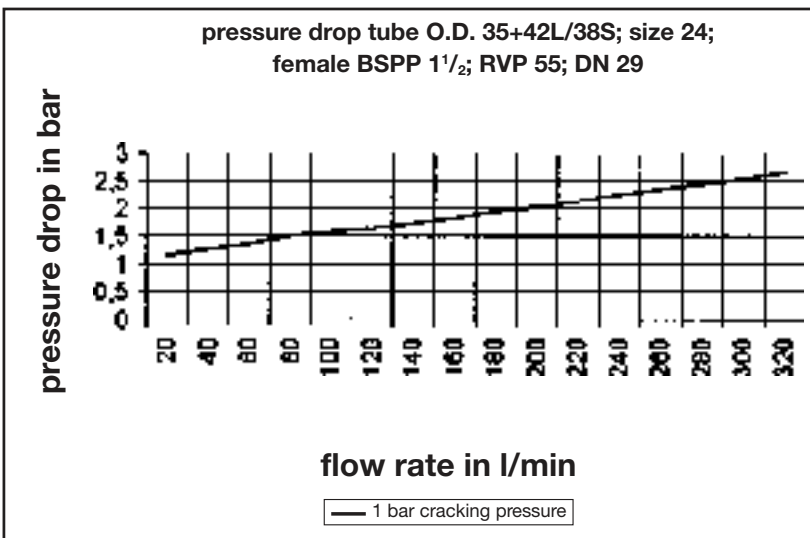
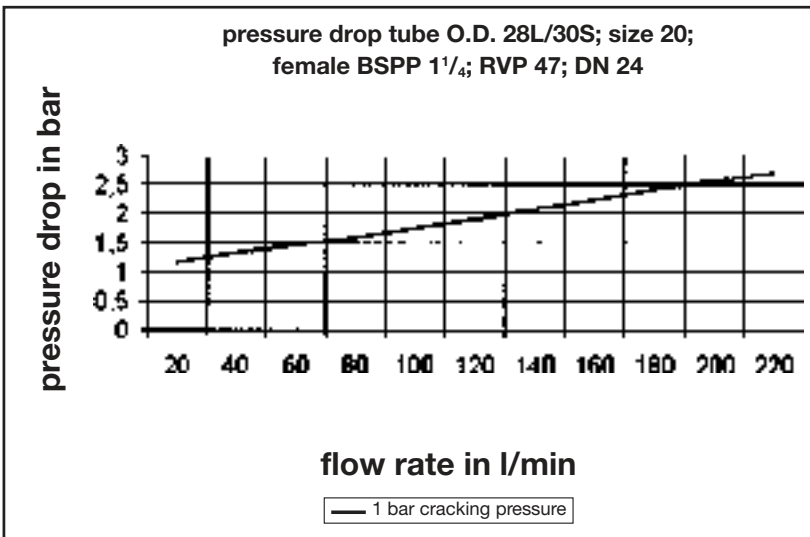
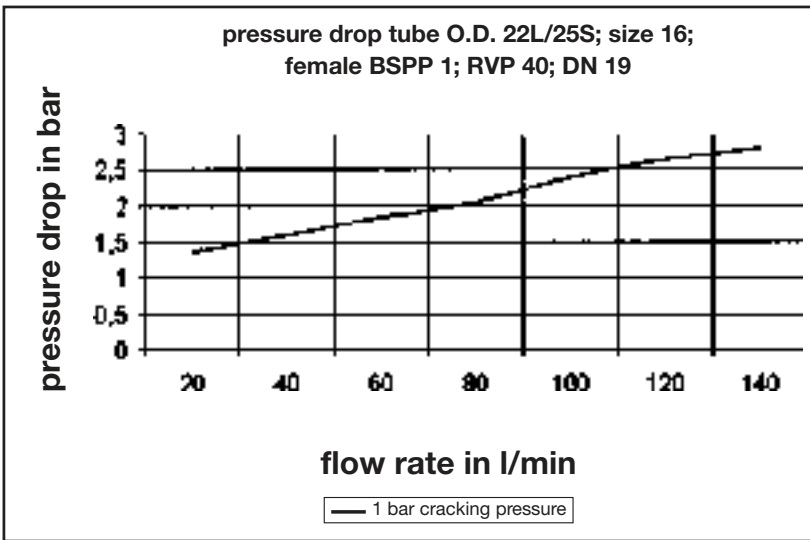

RHD Non return valve

EO 24° cone end / EO 24° cone end

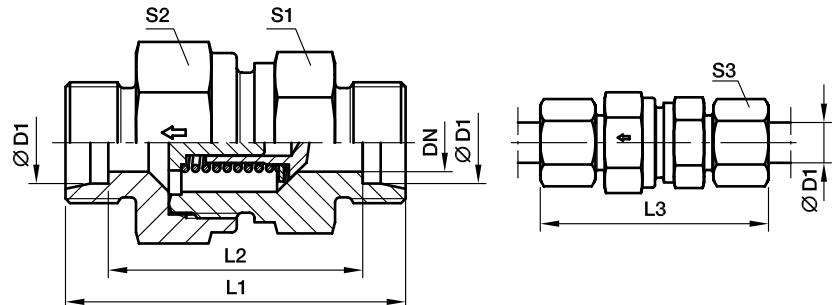

Series	D1 	DN	L1	L2	L3	S1	S2	S3	Weight g/1 piece	Order code*	PN (bar) ¹⁾		
											CF	A3C	71
L ³⁾	06	3.5	43	29.0	58.0	17	17	14	46	RHD06LOMD	400	250	250
	08	5.5	44	30.0	59.0	19	19	17	61	RHD08LOMD	400	250	250
	10	7.5	54.5	40.5	69.5	22	24	19	104	RHD10LOMD	400	250	250
	12	9.5	57.5	43.5	72.5	27	30	22	166	RHD12LOMD	400	250	250
	15	11.5	61.5	47.5	77.5	27	32	27	192	RHD15LOMD	400	250	250
	18	14.0	66.5	51.5	83.5	36	36	32	292	RHD18LOMD	400	160	160
	22	18.0	76.5	61.5	93.5	41	46	36	472	RHD22LOMD	250	160	160
	28	23.0	84.5	69.5	102.5	50	55	41	746	RHD28LOMD	250	100	100
	35	29.0	95.5	74.5	117.5	60	60	50	1062	RHD35LOMD	250	100	100
	42	29.0	96	74.0	119.0	65	70	60	1518	RHD42LOMD	250	100	100
S ⁴⁾	06	3.5	48.5	34.5	63.5	19	19	17	70	RHD06SOMD	420	400	400
	08	3.5	48.5	34.5	63.5	19	19	19	74	RHD08SOMD	420	400	400
	10	5.5	55.5	40.5	72.5	22	24	22	121	RHD10SOMD	420	400	400
	12	7.5	57.5	42.5	74.5	24	27	24	148	RHD12SOMD	420	400	400
	14	9.5	63.5	47.5	82.5	27	32	27	218	RHD14SOMD	420	315	315
	16	11.5	67.5	50.5	86.5	32	36	30	286	RHD16SOMD	420	315	315
	20	15.0	75.5	54.5	97.5	41	46	36	506	RHD20SOMD	420	250	250
	25	19.0	82.5	58.5	106.5	46	50	46	639	RHD25SOMD	420	250	250
	30	24.0	96.5	69.5	122.5	60	60	50	1157	RHD30SOMD	250	250	250
	38	29.0	107.5	75.5	136.5	65	70	60	1650	RHD38SOMD	250	250	250

¹⁾ Pressure shown = item deliverable

³⁾ L = light series; ⁴⁾ S = heavy series

$\frac{\text{PN (bar)}}{10} = \text{PN (MPa)}$

Delivery without nut and ring. Information on ordering complete fittings or alternative sealing materials see page 17.

*Please add the **suffixes** below according to the material/surface required.

Order code suffixes			
Material	Suffix surface and material	Example	Standard sealing material (no additional suffix needed)
Steel, zinc plated., chrome ⁶⁾ -free	CF	RHD06LOMDCF	NBR
Steel, zinc yellow plated	A3C	RHD06LOMDA3C	NBR
Stainless steel	71	RHD06LOMD71	VIT

RHV-R-ED Non return valve

EO 24° cone end / Male BSPP thread – ED-seal (ISO 1179)

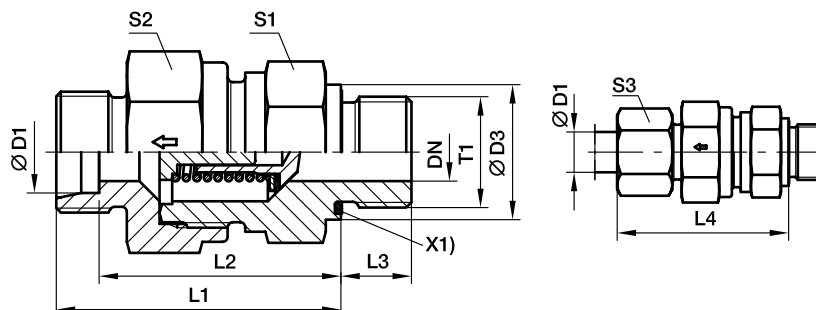

X1) Eolastic sealing

Series	D1	T1	DN	D3	L1	L2	L3	L4	S1	S2	S3	Weight g/1 piece	Order code*	PN (bar) ¹⁾		
														CF	A3C	71
L ³⁾	06	G 1/8 A	3.5	14	35	28.0	8	42.5	17	17	14	47	RHV06LREDOMD	400	250	250
	08	G 1/4 A	5.5	19	37	30.0	12	44.5	19	19	17	62	RHV08LREDOMD	400	250	250
	10	G 1/4 A	7.5	19	45.5	38.5	12	53.0	22	24	19	105	RHV10LREDOMD	400	250	250
	12	G 3/8 A	9.5	22	49.5	42.5	12	57.0	27	30	22	175	RHV12LREDOMD	400	250	250
	15	G 1/2 A	11.5	27	52.5	45.5	14	60.5	27	32	27	205	RHV15LREDOMD	400	250	250
	18	G 1/2 A	14.0	27	57.5	50.0	14	66.0	36	36	32	294	RHV18LREDOMD	400	160	160
	22	G 3/4 A	18.0	32	62.5	55.0	16	71.0	41	46	36	450	RHV22LREDOMD	250	160	160
	28	G 1 A	23.0	40	70.5	63.0	18	79.5	50	55	41	720	RHV28LREDOMD	250	100	100
	35	G 1 1/4 A	29.0	50	79.5	69.0	20	90.5	60	60	50	1050	RHV35LREDOMD	250	100	100
	42	G 1 1/2 A	29.0	55	79.5	68.5	22	91.0	65	70	60	1560	RHV42LREDOMD	250	100	100
S ⁴⁾	06	G 1/4 A	3.5	19	38.5	31.5	12	46.0	19	19	17	73	RHV06SREDOMD	420	400	400
	08	G 1/4 A	3.5	19	38.5	31.5	12	46.0	19	19	19	79	RHV08SREDOMD	420	400	400
	10	G 3/8 A	5.5	22	45.5	38.0	12	54.0	22	24	22	132	RHV10SREDOMD	420	400	400
	12	G 3/8 A	7.5	22	48.5	41.0	12	57.0	24	27	24	153	RHV12SREDOMD	420	400	400
	14	G 1/2 A	9.5	27	52.5	44.5	14	62.0	27	32	27	230	RHV14SREDOMD	420	315	315
	16	G 1/2 A	11.5	27	56.5	48.0	14	66.0	32	36	30	293	RHV16SREDOMD	420	315	315
	20	G 3/4 A	15.0	32	62.5	52.0	16	73.5	41	46	36	511	RHV20SREDOMD	420	250	250
	25	G 1 A	19.0	40	66.5	54.5	18	78.5	46	50	46	648	RHV25SREDOMD	420	250	250
	30	G 1 1/4 A	24.0	50	77.5	64.0	20	90.5	60	60	50	1176	RHV30SREDOMD	250	250	250
	38	G 1 1/2 A	29.0	55	85.5	69.5	22	100.0	65	70	60	1624	RHV38SREDOMD	250	250	250

¹⁾ Pressure shown = item deliverable

³⁾ L = light series; ⁴⁾ S = heavy series

$\frac{PN \text{ (bar)}}{10} = PN \text{ (MPa)}$

Delivery without nut and ring. Information on ordering complete fittings or alternative sealing materials see page 17.

*Please add the **suffixes** below according to the material/surface required.

Order code suffixes			
Material	Suffix surface and material	Example	Standard sealing material (no additional suffix needed)
Steel, zinc plated., chrome ⁶⁾ -free	CF	RHV06LREDOMDCF	NBR
Steel, zinc yellow plated	A3C	RHV06LREDOMDA3C	NBR
Stainless steel	71	RHV06LREDOMD71	VIT

RHZ-R-ED Non return valve

Male BSPP thread – ED-seal (ISO 1179) / EO 24° cone end

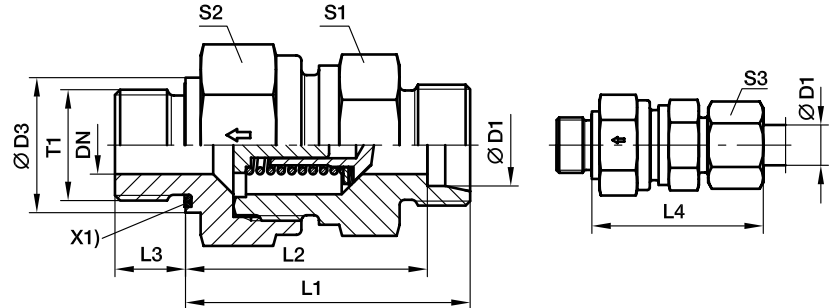

X1) Eolastic sealing

Series	D1	T1	DN	D3	L1	L2	L3	L4	S1	S2	S3	Weight g/1 piece	Order code*	PN (bar) ¹⁾		
														CF	A3C	71
L ³⁾	06	G 1/8 A	3.5	14	33.5	26.5	8	41.0	17	17	14	44	RHZ06LREDOMD	400	250	250
	08	G 1/4 A	5.5	19	35.5	28.5	12	43.0	19	19	17	59	RHZ08LREDOMD	400	250	250
	10	G 1/4 A	7.5	19	45.5	38.5	12	53.0	22	24	19	125	RHZ10LREDOMD	400	250	250
	12	G 3/8 A	9.5	22	47.5	40.5	12	55.0	27	30	22	161	RHZ12LREDOMD	400	250	250
	15	G 1/2 A	11.5	27	49.5	42.5	14	57.5	27	32	27	186	RHZ15LREDOMD	400	250	250
	18	G 1/2 A	14.0	27	55.5	48.0	14	64.0	36	36	32	275	RHZ18LREDOMD	400	160	160
	22	G 3/4 A	18.0	32	63.5	56.0	16	72.0	41	46	36	463	RHZ22LREDOMD	250	160	160
	28	G 1 A	23.0	40	71.5	64.0	18	80.5	50	55	41	721	RHZ28LREDOMD	250	100	100
	35	G 1 1/4 A	29.0	50	80.5	70.0	20	91.5	60	60	50	1073	RHZ35LREDOMD	250	100	100
	42	G 1 1/2 A	29.0	55	81.5	70.5	22	93.0	65	70	60	1602	RHZ42LREDOMD	250	100	100
S ⁴⁾	06	G 1/4 A	3.5	19	38.5	31.5	12	46.0	19	19	17	71	RHZ06SREDOMD	420	400	400
	08	G 1/4 A	3.5	19	38.5	31.5	12	46.0	19	19	19	74	RHZ08SREDOMD	420	400	400
	10	G 3/8 A	5.5	22	45.5	38.0	12	54.0	22	24	22	128	RHZ10SREDOMD	420	400	400
	12	G 3/8 A	7.5	22	48.5	41.0	12	57.0	24	27	24	152	RHZ12SREDOMD	420	400	400
	14	G 1/2 A	9.5	27	51.5	43.5	14	61.0	27	32	27	223	RHZ14SREDOMD	420	315	315
	16	G 1/2 A	11.5	27	54.5	46.0	14	64.0	32	36	30	275	RHZ16SREDOMD	420	315	315
	20	G 3/4 A	15.0	32	60.5	50.0	16	71.5	41	46	36	490	RHZ20SREDOMD	420	250	250
	25	G 1 A	19.0	40	66.5	54.5	18	78.5	46	50	46	647	RHZ25SREDOMD	420	250	250
	30	G 1 1/4 A	24.0	50	77.5	64.0	20	90.5	60	60	50	1180	RHZ30SREDOMD	250	250	250
	38	G 1 1/2 A	29.0	55	87.5	71.5	22	102.0	65	70	60	1670	RHZ38SREDOMD	250	250	250

¹⁾ Pressure shown = item deliverable

³⁾ L = light series; ⁴⁾ S = heavy series

$\frac{PN \text{ (bar)}}{10} = PN \text{ (MPa)}$

Delivery without nut and ring. Information on ordering complete fittings or alternative sealing materials see page 17.

*Please add the **suffixes** below according to the material/ surface required.

Order code suffixes			
Material	Suffix surface and material	Example	Standard sealing material (no additional suffix needed)
Steel, zinc plated., chrome ⁶ -free	CF	RHZ06LREDOMDCF	NBR
Steel, zinc yellow plated	A3C	RHZ06LREDOMDA3C	NBR

RHV-M-ED Non return valve

EO 24° cone end / Male metric thread – ED-seal (ISO 9974)

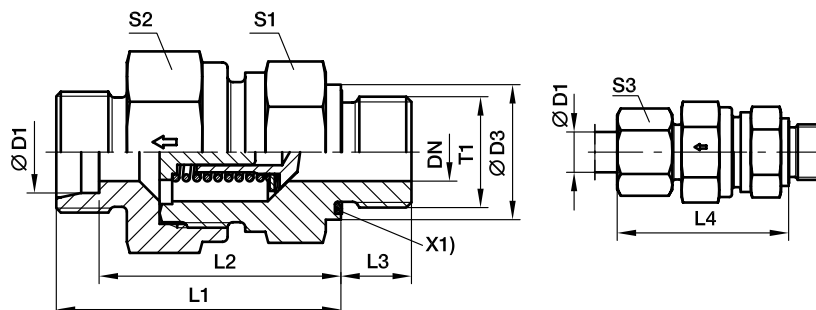

X1) Eolastic sealing

Series	D1	T1	DN	D3	L1	L2	L3	L4	S1	S2	S3	Weight g/1 piece	Order code*	PN (bar) ¹⁾		
														CF	A3C	71
L ³⁾	06	M 10	3.5	14	35	28.0	8	42.5	17	17	14	46	RHV06LMEDOMD	400	250	250
	08	M 12 1.5	5.5	17	36	29.0	12	43.5	19	19	17	58	RHV08LMEDOMD	400	250	250
	10	M 14 1.5	7.5	19	45.5	38.5	12	53.0	22	24	19	108	RHV10LMEDOMD	400	250	250
	12	M 16 1.5	9.5	22	49.5	42.5	12	57.0	27	30	22	173	RHV12LMEDOMD	400	250	250
	15	M 18 1.5	11.5	24	52.5	45.5	12	60.5	27	32	27	192	RHV15LMEDOMD	400	250	250
	18	M 22 1.5	14.0	27	57.5	50.0	14	66.0	36	36	32	298	RHV18LMEDOMD	400	160	160
	22	M 26 1.5	18.0	32	62.5	55.0	16	71.0	41	46	36	446	RHV22LMEDOMD	250	160	160
	28	M 33 2	23.0	40	70.5	63.0	18	79.5	50	55	41	722	RHV28LMEDOMD	250	100	100
	35	M 42 2	29.0	50	79.5	69.0	20	90.5	60	60	50	1053	RHV35LMEDOMD	250	100	100
	42	M 48 2	29.0	55	79.5	68.5	22	91.0	65	70	60	1563	RHV42LMEDOMD	250	100	100
S ⁴⁾	06	M 12 1.5	3.5	17	38.5	31.5	12	46.0	19	19	17	70	RHV06SMEDOMD	420	400	400
	08	M 14 1.5	3.5	19	38.5	31.5	12	46.0	19	19	19	76	RHV08SMEDOMD	420	400	400
	10	M 16 1.5	5.5	22	45.5	38.0	12	54.0	22	24	22	124	RHV10SMEDOMD	420	400	400
	12	M 18 1.5	7.5	24	48.5	41.0	12	57.0	24	27	24	157	RHV12SMEDOMD	420	400	400
	14	M 20 1.5	9.5	26	52.5	44.5	14	62.0	27	32	27	215	RHV14SMEDOMD	420	315	315
	16	M 22 1.5	11.5	27	56.5	48.0	14	66.0	32	36	30	296	RHV16SMEDOMD	420	315	315
	20	M 27 2	15.0	32	62.5	52.0	16	73.5	41	46	36	521	RHV20SMEDOMD	420	250	250
	25	M 33 2	19.0	40	66.5	54.5	18	78.5	46	50	46	648	RHV25SMEDOMD	420	250	250
	30	M 42 2	24.0	50	77.5	64.0	20	90.5	60	60	50	1178	RHV30SMEDOMD	250	250	250
	38	M 48 2	29.0	55	85.5	69.5	22	100.0	65	70	60	1627	RHV38SMEDOMD	250	250	250

¹⁾ Pressure shown = item deliverable

³⁾ L = light series; ⁴⁾ S = heavy series

$\frac{PN \text{ (bar)}}{10} = PN \text{ (MPa)}$

Delivery without nut and ring. Information on ordering complete fittings or alternative sealing materials see page 17.

*Please add the **suffixes** below according to the material/surface required.

Order code suffixes			
Material	Suffix surface and material	Example	Standard sealing material (no additional suffix needed)
Steel, zinc plated., chrome ⁶⁾ -free	CF	RHV06LMEDOMDCF	NBR
Steel, zinc yellow plated	A3C	RHV06LMEDOMDA3C	NBR
Stainless steel	71	RHV06LMEDOMD71	VIT

RHZ-M-ED Non return valve

Male metric thread – ED-seal (ISO 9974) / EO 24° cone end

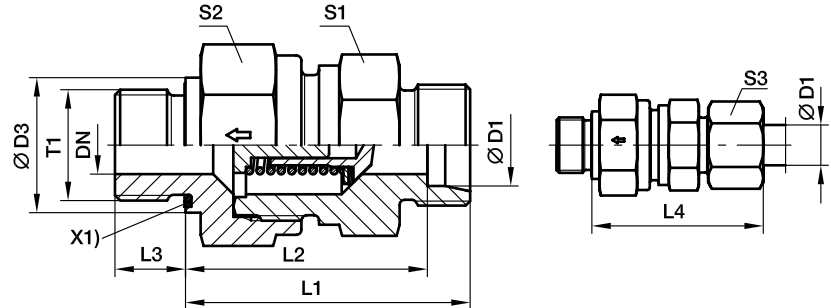

X1) Eolastic sealing

Series	D1	T1	DN	D3	L1	L2	L3	L4	S1	S2	S3	Weight g/1 piece	Order code*	PN (bar) ¹⁾		
														CF	A3C	71
L ³⁾	06	M 10 1	3.5	14	33.5	26.5	8	41.0	17	17	14	44	RHZ06LMEDOMD	400	250	250
	08	M 12 1.5	5.5	17	35.5	28.5	12	43.0	19	19	17	58	RHZ08LMEDOMD	400	250	250
	10	M 14 1.5	7.5	19	45.5	38.5	12	53.0	22	24	19	104	RHZ10LMEDOMD	400	250	250
	12	M 16 1.5	9.5	22	47.5	40.5	12	55.0	27	30	22	169	RHZ12LMEDOMD	400	250	250
	15	M 18 1.5	11.5	24	49.5	42.5	12	57.5	27	32	27	174	RHZ15LMEDOMD	400	250	250
	18	M 22 1.5	14.0	27	55.5	48.0	14	64.0	36	36	32	279	RHZ18LMEDOMD	400	160	160
	22	M 26 1.5	18.0	32	63.5	56.0	16	72.0	41	46	36	459	RHZ22LMEDOMD	250	160	160
	28	M 33 2	23.0	40	71.5	64.0	18	80.5	50	55	41	721	RHZ28LMEDOMD	250	100	100
	35	M 42 2	29.0	50	80.5	70.0	20	91.5	60	60	50	1078	RHZ35LMEDOMD	250	100	100
	42	M 48 2	29.0	55	81.5	70.5	22	93.0	65	70	60	1601	RHZ42LMEDOMD	250	100	100
S ⁴⁾	06	M 12 1.5	3.5	17	38.5	31.5	12	46.0	19	19	17	70	RHZ06SMEDOMD	420	400	400
	08	M 14 1.5	3.5	19	38.5	31.5	12	46.0	19	19	19	75	RHZ08SMEDOMD	420	400	400
	10	M 16 1.5	5.5	22	45.5	38.0	12	54.0	22	24	22	123	RHZ10SMEDOMD	420	400	400
	12	M 18 1.5	7.5	24	48.5	41.0	12	57.0	24	27	24	157	RHZ12SMEDOMD	420	400	400
	14	M 20 1.5	9.5	26	51.5	43.5	14	61.0	27	32	27	214	RHZ14SMEDOMD	420	315	315
	16	M 22 1.5	11.5	27	54.5	46.0	14	64.0	32	36	30	279	RHZ16SMEDOMD	420	315	315
	20	M 27 2	15.0	32	60.5	50.0	16	71.5	41	46	36	487	RHZ20SMEDOMD	420	250	250
	25	M 33 2	19.0	40	66.5	54.5	18	78.5	46	50	46	647	RHZ25SMEDOMD	420	250	250
	30	M 42 2	24.0	50	77.5	64.0	20	90.5	60	60	50	1180	RHZ30SMEDOMD	250	250	250
	38	M 48 2	29.0	55	87.5	71.5	22	102.0	65	70	60	1669	RHZ38SMEDOMD	250	250	250

¹⁾ Pressure shown = item deliverable

³⁾ L = light series; ⁴⁾ S = heavy series

$\frac{PN \text{ (bar)}}{10} = PN \text{ (MPa)}$

Delivery without nut and ring. Information on ordering complete fittings or alternative sealing materials see page 17.

*Please add the **suffixes** below according to the material/surface required.

Order code suffixes			
Material	Suffix surface and material	Example	Standard sealing material (no additional suffix needed)
Steel, zinc plated., chrome ⁶⁾ -free	CF	RHZ06LMEDOMDCF	NBR
Steel, zinc yellow plated	A3C	RHZ06LMEDOMDA3C	NBR
Stainless steel	71	RHZ06LMEDOMD71	VIT

RHDI Non return valve

Female BSPP thread (ISO 1179-1) / Female BSPP thread (ISO 1179-1)

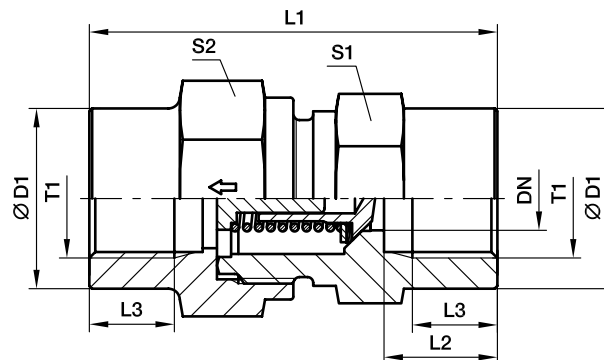

Series	T1	DN	D1	L1	L2	L3	S1	S2	Weight g/1 piece	Order code*	CF	A3C ¹⁾	71
L ³⁾	G11/18	3.5	19	42.5	12.0	8.0	19	19	76	RHDI1/8	400	400	400
	G 1/4	3.5	19	51.0	16.0	12.0	19	19	82	RHDI1/4	400	400	400
	G 3/8	7.5	24	60.0	17.0	12.0	24	27	157	RHDI3/8	400	400	400
	G 1/2	11.5	32	72.0	20.0	15.0	32	36	344	RHDI1/2	315	315	315
	G 3/4	15.0	41	84.0	22.0	16.5	41	46	664	RHDI3/4	250	250	250
	G 1	19.0	46	95.0	25.5	19.0	46	50	821	RHDI1	250	250	250
G 11/4	24.0	60	110.0	28.0	21.5	60	60	1581	RHDI11/4	250	250	250	
G 11/2	29.0	65	114.0	28.5	22.0	65	70	1919	RHDI11/2	250	250	250	

¹⁾ Pressure shown = item deliverable

³⁾ L = light series

$$\frac{\text{PN (bar)}}{10} = \text{PN (MPa)}$$

Delivery without nut and ring. Information on ordering complete fittings or alternative sealing materials see page I7.

Order code suffixes			
Material	Suffix surface and material	Example	Standard sealing material (no additional suffix needed)
Steel, zinc plated., chrome ⁶⁾ -free	CF	RHDI1/8CF	NBR
Steel, zinc yellow plated	A3C	RHDI1/8A3C	NBR
Stainless steel	71	RHDI1/871	VIT

*Please add the **suffixes** below according to the material/surface required.

RVP Non return valve cartridge

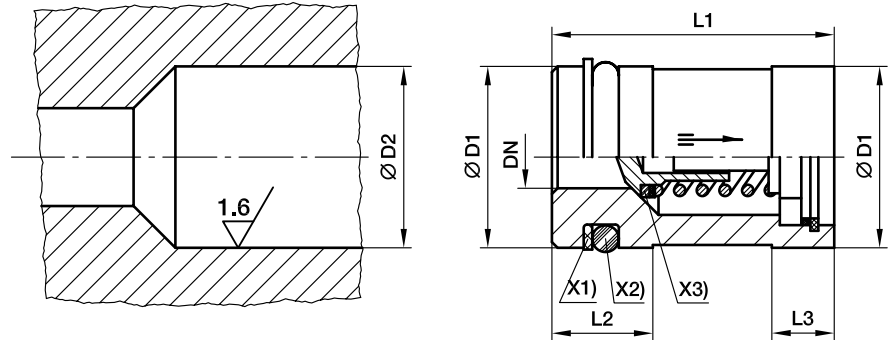

- X1) Supporting ring PTFE
- X2) O-ring NBR
- X3) Sealing disc NBR

Valve ITL	DN	D1	D2	L1 ±0,15	L2	L3	O-ring	Supporting ring	Weight g/1 piece	Order code*	PN (bar) ¹⁾		
											CF	A3C	71
6-L/6u.8-S	3.5	12.945 ±0.055	13 ^{+0.12 +0.05}	23.15	9.5	6.0	8.3 2.4	SRA 13-2.05-1.0	21	RVP13	420	400	400
8-L/10-S	5.5	15.945 ±0.055	16 ^{+0.12 +0.05}	26.65	9.5	6.5	11.3 2.4	SRA 16-2.05-1.0	32	RVP16	420	400	400
10-L/12-S	7.5	19.935 ±0.065	20 ^{+0.142 +0.065}	30.15	9.5	6.5	15.3 2.4	SRA 20-2.05-1.0	54	RVP20	420	400	400
12-L/14-S	9.5	23.935 ±0.065	24 ^{+0.149 +0.065}	35.15	12.0	7.5	18.2 3	SRA 24-2.6-1.0	80	RVP24	420	315	315
15-L/16-S	11.5	26.935 ±0.065	27 ^{+0.149 +0.065}	38.15	12.0	7.5	21.2 3	SRA 27-2.6-1.0	105	RVP27	420	315	315
18-L/20-S	15.0	34.92 ±0.08	35 ^{+0.18 +0.08}	44.65	12.0	9.5	29.2 3	SRA 35-2.5-1.0	204	RVP35	420	250	250
22-L/25-S	19.0	39.92 ±0.08	40 ^{+0.18 +0.08}	50.65	12.0	11.0	34.2 3	SRA 40-2.5-1.0	275	RVP40	420	250	250
28-L/30-S	24.0	46.92 ±0.08	47 ^{+0.18 +0.08}	60.15	13.0	13.0	41.2 3	SRA 47-2.6-1.5	412	RVP47	250	250	250
35-L/38-S	29.0	54.905 ±0.095	55 ^{+0.22 +0.1}	70.15	16.0	13.0	44.2 5.7	SRA 55-5.1-1.5	607	RVP55	250	250	250

¹⁾ Pressure shown = item deliverable

$$\frac{\text{PN (bar)}}{10} = \text{PN (MPa)}$$

Delivery without nut and ring. Information on ordering complete fittings or alternative sealing materials see page 17.

*Please add the **suffixes** below according to the material/surface required.

Order code suffixes			
Material	Suffix surface and material	Example	Standard sealing material (no additional suffix needed)
Steel, zinc plated., chrome ⁶ -free	CF	RHP13CF	NBR
Steel, zinc yellow plated	A3C	RHP13A3C	NBR
Stainless steel	71	RHP1371	VIT

I-TL Internal parts of non return valve

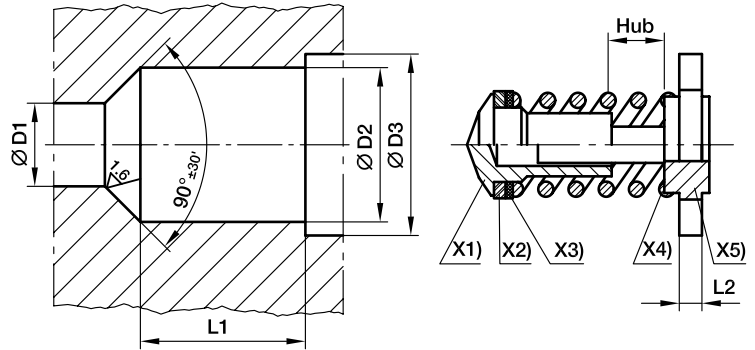

- X1) poppet
- X2) sealing disc (smooth side to the poppet)
- X3) cover disc
- X4) spring
- X5) passage disc

Series	Tube O.D.	D1 ^{+0.1}	D2 ^{+0.1}	D3 ^{+0.1}	L1 ^{±0.1}	L2	Hub	Weight g/1 piece	Order code*	PN (bar) ¹⁾	
										A3C	71
L/S/S	06/06/08	3.5	7.5	8.6	8.2	2.0	1.0	2	ITL06L/06+08S	*	*
L/S	08/10	5.5	10.2	11.6	11.0	2.0	1.7	4	ITL08L/10S	*	*
L/S	10/12	7.5	13.0	14.1	14.0	2.0	2.3	7	ITL10L/12S	*	*
L/S	12/14	9.5	16.7	18.1	16.5	2.5	2.9	13	ITL12L/14S	*	*
L/S	15/16	11.5	19.5	20.6	19.0	2.5	3.5	18	ITL15L/16S	*	*
L/S	18/20	15.0	25.2	27.1	22.5	3.0	4.4	37	ITL18L/20S	*	*
L/S	22/25	19.0	30.8	32.6	27.0	3.0	5.5	54	ITL22L/25S	*	*
L/S	28/30	24.0	38.6	40.6	32.5	3.5	7.3	107	ITL28L/30S	*	*
L/L/S	35/38/42	29.0	45.7	48.1	37.5	3.5	8.9	144	ITL35L+42I/38S	*	*

* = item deliverable

Delivery without nut and ring. Information on ordering complete fittings or alternative sealing materials see page 17.

*Please add the **suffixes** below according to the material/ surface required.

Order code suffixes			
Material	Suffix surface and material	Example	Standard sealing material (no additional suffix needed)
Steel, zinc yellow plated	A3C	ITL06L/06+008S	NBR
Stainless steel	71	ITL06L71/06+008S	VIT

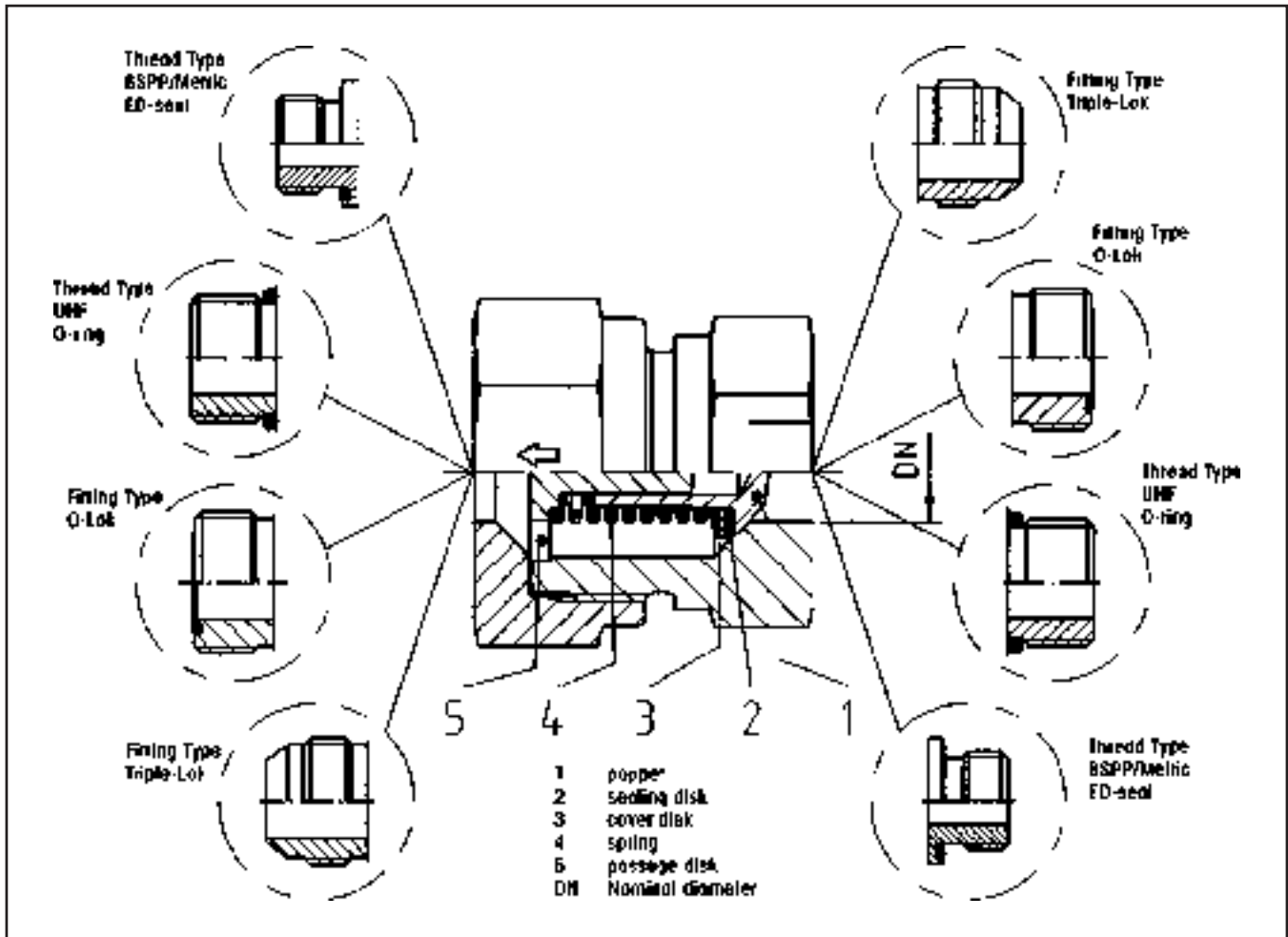
RHD/V/Z Non return valves with O-Lok® or Triple-Lok® connections

Material:

- Steel zinc-plated (A3C) or (CF chromium⁶-free), seals in NBR (e.g. Perbunan*)
- Internal parts in stainless steel with FKM (Viton) also available on request.

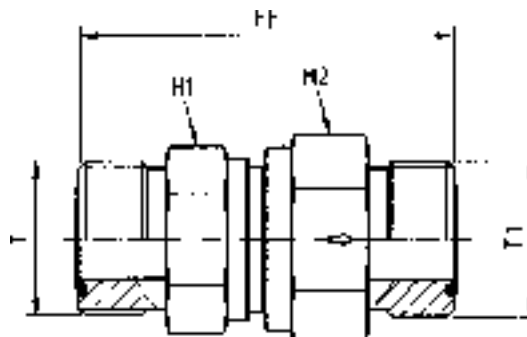

RHDMLOS Non return valve

O-Lok® ORFS end / O-Lok® ORFS end



Tube 1 O.D.		Tube 2 O.D.		ORFS (UN/UNF thread T	ORFS (UN/UNF) thread T1	H1	H2	FF	DN (Nom. diam.)	Weight g/1 piece	Order code*	PN (bar) ¹⁾	
mm	Inch	mm	Inch									CF	A3C
6	1/4	6	1/4	9/16-18UNF	9/16-18UNF	19	19	44.5	3.5	108	4RHDMLOS	420	400
8, 10	5/16, 3/8	8, 10	5/16, 3/8	11/16-16UNF	11/16-16UNF	22	24	53.5	5.5	188	6RHDMLOS	420	400
12	1/2	12	1/2	13/16-16UNF	13/16-16UNF	24	27	59.5	7.5	223	8RHDMLOS	420	400
14, 15, 16	5/8	14, 15, 16	5/8	1-14UNF	1-14UNF	32	36	70.5	11.5	428	10RHDMLOS	420	315
18, 20	3/4	18, 20	3/4	1 3/16-12UNF	1 3/16-12UNF	41	46	77.5	15.0	731	12RHDMLOS	420	250
22, 25	1	22, 25	1	1 7/16-12UNF	1 7/16-12UNF	46	50	81.5	19.0	1076	16RHDMLOS	420	250
28, 30, 32	1 1/4	28, 30, 32	1 1/4	1 11/16-12UNF	1 11/16-12UNF	60	60	91.5	24.0	1630	20RHDMLOS	250	250
35, 38	1 1/2	35, 38	1 1/2	2-12UNF	2-12UNF	65	70	98.5	29.0	2362	24RHDMLOS	250	250

¹⁾ Pressure shown = item deliverable

$$\frac{\text{PN (bar)}}{10} = \text{PN (MPa)}$$

Delivery without nut and ring. Information on ordering complete fittings or alternative sealing materials see page 17.

*Please add the **suffixes** below according to the material/ surface required.

Order code suffixes			
Material	Suffix surface and material	Example	Standard sealing material (no additional suffix needed)
Steel, zinc plated., chrome ⁶ -free	CF	4RHDMLOSCF	NBR
Steel, zinc yellow plated	A3C (no suffix needed)	4RHDMLOS	NBR

RHV42EDMLOS Non return valve

Male BSPP thread – ED-seal (ISO 1179) / O-Lok® ORFS end

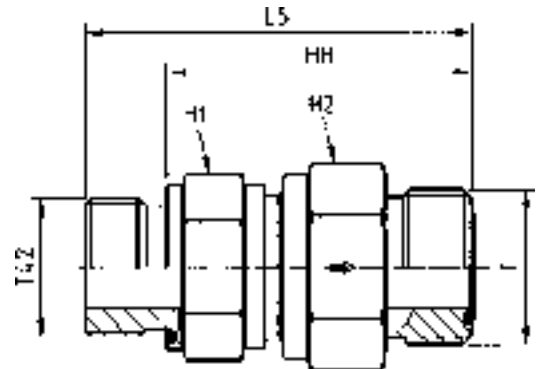

Tube O.D.		BSPP thread T42	ORFS (UN/UNF) thread T	H1	H2	L5	HH	DN (Nom. diam.)	Weight g/1 piece	Order code*	PN (bar) ¹⁾	
mm	Inch										CF	A3C
6	1/4	G 1/8	9/16-18UNF	19	19	44.5	36.5	3.5	92	4RHV42EDMLOS	420	400
8, 10	5/16, 3/8	G 1/4	11/16-16UNF	22	24	56.5	44.5	6.5	165	6RHV42EDMLOS	420	400
12	1/2	G 3/8	13/16-16UNF	24	27	61.5	49.5	7.5	191	8RHV42EDMLOS	420	400
14, 15, 16	5/8	G 1/2	1-14UNF	32	36	70.0	56.0	11.5	366	10RHV42EDMLOS	420	315
18, 20	3/4	G 3/4	1 3/16-12UNF	41	46	77.5	63.5	15.0	631	12RHV42EDMLOS	420	250
22, 25	1	G 1	1 7/16-12UNF	46	50	84.0	66.0	19.0	863	16RHV42EDMLOS	420	250
28, 30, 32	1 1/4	G 1 1/4	1 11/16-12UNF	60	60	95.0	75.0	24.0	1403	20RHV42EDMLOS	250	250
35, 38	1 1/2	G 1 1/2	2-12UNF	65	70	105.0	83.0	29.0	1969	24RHV42EDMLOS	250	250

¹⁾ Pressure shown = item deliverable

$$\frac{\text{PN (bar)}}{10} = \text{PN (MPa)}$$

Delivery without nut and ring. Information on ordering complete fittings or alternative sealing materials see page 17.

*Please add the **suffixes** below according to the material/surface required.

Order code suffixes			
Material	Suffix surface and material	Example	Standard sealing material (no additional suffix needed)
Steel, zinc plated., chrome ⁶ -free	CF	4RHV42EDMLOSCF	NBR
Steel, zinc yellow plated	A3C (no suffix needed)	4RHV42EDMLOS	NBR

RHZ42EDMLOS Non return valve

O-Lok® ORFS end / Male BSPP thread – ED-seal (ISO 1179)

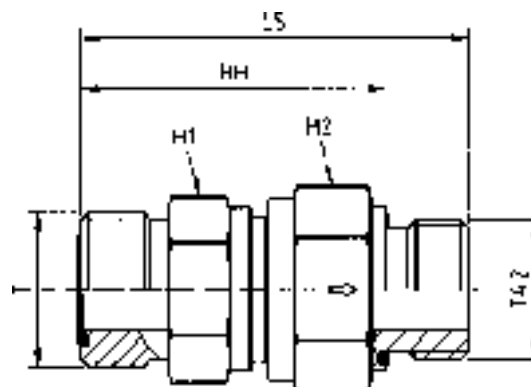

Tube O.D.		BSPP thread T42	ORFS (UN/UNF) thread T	H1	H2	L5	HH	DN (Nom. diam.)	Weight g/1 piece	Order code*	PN (bar) ¹⁾	
mm	Inch										CF	A3C
6	1/4	G 1/8	9/16-18UNF	19	19	44.5	36.5	3.5	91	4RHZ42EDMLOS	420	400
8, 10	5/16, 3/8	G 1/4	11/16-16UNF	22	24	56.5	44.5	6.5	161	6RHZ42EDMLOS	420	400
12	1/2	G 3/8	13/16-16UNF	24	27	61.5	49.5	7.5	190	8RHZ42EDMLOS	420	400
14, 15, 16	5/8	G 1/2	1-14UNF	32	36	70.0	56.0	11.5	348	10RHZ42EDMLOS	420	315
18, 20	3/4	G 3/4	1 3/16-12UNF	41	46	77.5	53.5	15.0	634	12RHZ42EDMLOS	420	250
22, 25	1	G 1	1 7/16-12UNF	46	50	84.0	66.0	19.0	863	16RHZ42EDMLOS	420	250
28, 30, 32	1 1/4	G 1 1/4	1 11/16-12UNF	60	60	95.0	75.0	24.0	1397	20RHZ42EDMLOS	250	250
35, 38	1 1/2	G 1 1/2	2-12UNF	65	70	105.0	83.0	29.0	2001	24RHZ42EDMLOS	250	250

¹⁾ Pressure shown = item deliverable

$$\frac{\text{PN (bar)}}{10} = \text{PN (MPa)}$$

Delivery without nut and ring. Information on ordering complete fittings or alternative sealing materials see page 17.

*Please add the **suffixes** below according to the material/surface required.

Order code suffixes			
Material	Suffix surface and material	Example	Standard sealing material (no additional suffix needed)
Steel, zinc plated., chrome ⁶ -free	CF	4RHZ42EDMLOSCF	NBR
Steel, zinc yellow plated	A3C (no suffix needed)	4RHZ42EDMLOS	NBR

RHV50MLOS Non return valve

Male UN/UNF thread – O-ring (ISO 11926) / O-Lok® ORFS end

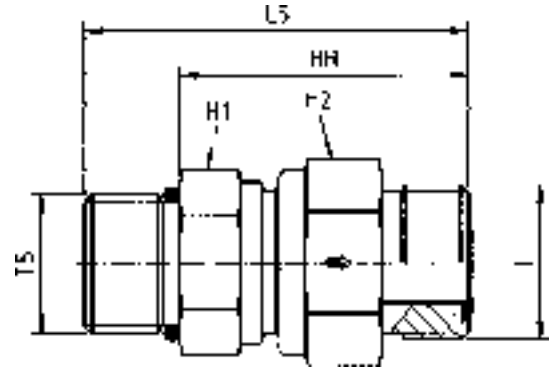

Tube O.D.		UNF male thread T5	ORFS (UN/UNF) thread T	H1	H2	L5	HH	DN (Nom. diam.)	Weight g/1 piece	Order code*	PN (bar) ¹⁾	
mm	Inch										CF	A3C
6	1/4	7/16-20UNF	9/16-18UNF	19	19	45.5	34.5	3.5	92	4RHV50MLOS	420	400
8, 10	5/16, 3/8	9/16-18UNF	11/16-16UNF	22	24	54.5	42.5	5.5	165	6RHV50MLOS	420	400
12	1/2	3/4-16UNF	13/16-16UNF	24	27	60.5	46.5	5.5	165	8RHV50MLOS	420	400
14, 15, 16	5/8	7/8-14UNS	1-14UNF	32	36	71.0	55.0	11.5	366	10RHV50MLOS	420	315
18, 20	3/4	1 1/16-12UN	1 3/16-12UNF	41	46	79.0	60.5	15.0	631	12RHV50MLOS	420	250
22, 25	1	1 5/16-12UN	1 7/16-12UNF	46	50	82.5	64.0	19.0	863	16RHV50MLOS	420	250
28, 30, 32	1 1/4	1 5/8-12UN	1 11/16-12UNF	60	60	92.5	74.0	24.0	1403	20RHV50MLOS	250	250
35, 38	1 1/2	1 7/8-12UN	2-12UNF	65	70	99.5	81.0	29.0	1969	24RHV50MLOS	250	250

¹⁾ Pressure shown = item deliverable

$$\frac{\text{PN (bar)}}{10} = \text{PN (MPa)}$$

Delivery without nut and ring. Information on ordering complete fittings or alternative sealing materials see page 17.

*Please add the **suffixes** below according to the material/surface required.

Order code suffixes			
Material	Suffix surface and material	Example	Standard sealing material (no additional suffix needed)
Steel, zinc plated., chrome ⁶ -free	CF	RHV50MLOSCF	NBR
Steel, zinc yellow plated	A3C (no suffix needed)	4RHV50MLOS	NBR

RHZ5OMLOS Non return valve

O-Lok® ORFS end / Male UN/UNF thread – O-ring (ISO 11926)

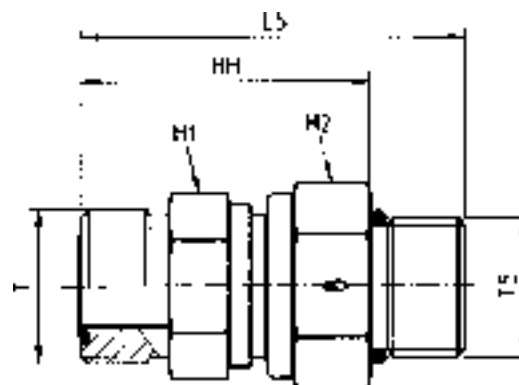

Tube O.D.		UNF male thread T5	ORFS (UN/UNF) thread T	H1	H2	L5	HH	DN (Nom. diam.)	Weight g/1 piece	Order code*	PN (bar) ¹⁾	
mm	Inch										CF	A3C
6	1/4	7/16-20UNF	9/16-18UNF	19	19	45.5	34.5	3.5	91	4RHZ5OMLOS	420	400
8, 10	5/16, 3/8	9/16-18UNF	11/16-16UNF	22	24	54.5	42.5	5.5	161	6RHZ5OMLOS	420	400
12	1/2	3/4-16UNF	13/16-16UNF	24	27	60.5	46.5	5.5	161	8RHZ5OMLOS	420	400
14, 15, 16	5/8	7/8-14UNS	1-14UNF	32	36	71.0	55.0	11.5	348	10RHZ5OMLOS	420	315
18, 20	3/4	1 1/16-12UN	1 3/16-12UNF	41	46	79.0	60.5	15.0	634	12RHZ5OMLOS	420	250
22, 25	1	1 5/16-12UN	1 7/16-12UNF	46	50	82.5	64.0	19.0	863	16RHZ5OMLOS	420	250
28, 30, 32	1 1/4	1 5/8-12UN	1 11/16-12UNF	60	60	92.5	74.0	24.0	1397	20RHZ5OMLOS	250	250
35, 38	1 1/2	1 7/8-12UN	2-12UNF	65	70	99.5	81.0	29.0	2001	24RHZ5OMLOS	250	250

¹⁾ Pressure shown = item deliverable

$$\frac{\text{PN (bar)}}{10} = \text{PN (MPa)}$$

Delivery without nut and ring. Information on ordering complete fittings or alternative sealing materials see page 17.

*Please add the **suffixes** below according to the material/surface required.

Order code suffixes			
Material	Suffix surface and material	Example	Standard sealing material (no additional suffix needed)
Steel, zinc plated., chrome ⁶ -free	CF	4RHZ5OMLOSCF	NBR
Steel, zinc yellow plated	A3C (no suffix needed)	4RHZ5OMLOS	NBR

RHV82EDMLOS Non return valve

Male metric thread – ED-seal (ISO 9974) / O-Lok® ORFS end

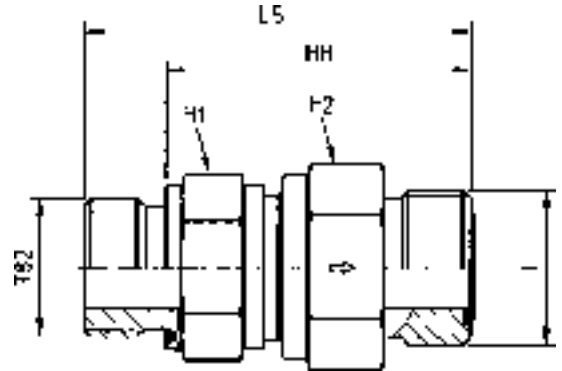

Tube O.D.		metric thread T82	ORFS (UN/UNF) thread T	H1	H2	L5	HH	DN (Nom. diam.)	Weight g/1 piece	Order code*	PN (bar) ¹⁾	
mm	Inch										CF	A3C
6	1/4	M12 1.5	9/16-18UNF	19	19	48.5	36.5	3.5	89	4M12RHV82EDMLOS	420	400
8, 10	5/16, 3/8	M16 1.5	11/16-16UNF	22	24	56.5	44.5	5.5	157	6M16RHV82EDMLOS	420	400
12	1/2	M18 1.5	13/16-16UNF	24	27	61.5	49.5	7.5	195	8M18RHV82EDMLOS	420	400
14, 15, 16	5/8	M22 1.5	1-14UNF	32	36	72.0	58.0	11.5	369	10M22RHV82EDMLOS	420	315
18, 20	3/4	M27 2.0	1 3/16-12UNF	41	46	79.5	63.5	15.0	628	12M27RHV82EDMLOS	420	250
22, 25	1	M33 2.0	1 7/16-12UNF	46	50	84.0	66.0	19.0	867	16M33RHV82EDMLOS	420	250
28, 30, 32	1 1/4	M42 2.0	1 11/16-12UNF	60	60	95.0	75.0	24.0	1409	20M42RHV82EDMLOS	250	250
35, 38	1 1/2	M48 2.0	2-12UNF	65	70	103.0	81.0	29.0	1970	24M48RHV82EDMLOS	250	250

¹⁾ Pressure shown = item deliverable

$$\frac{\text{PN (bar)}}{10} = \text{PN (MPa)}$$

Delivery without nut and ring. Information on ordering complete fittings or alternative sealing materials see page 17.

*Please add the **suffixes** below according to the material/ surface required.

Order code suffixes			
Material	Suffix surface and material	Example	Standard sealing material (no additional suffix needed)
Steel, zinc plated., chrome ⁶ -free	CF	4M12RHV82EDMLOSCF	NBR
Steel, zinc yellow plated	A3C (no suffix needed)	4M12RHV82EDMLOS	NBR

RHZ82EDMLOS Non return valve

O-Lok® ORFS end / Male metric thread – ED-seal (ISO 9974)

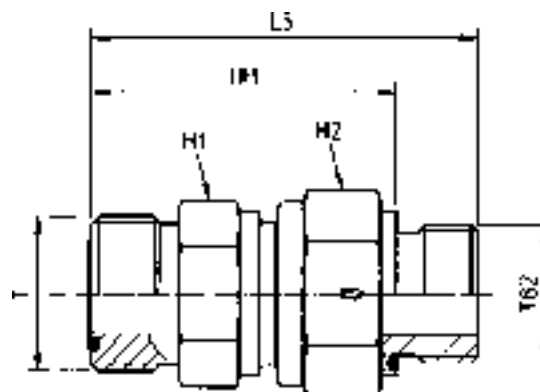

Tube O.D.		metric thread T82	ORFS (UN/UNF) thread T	H1	H2	L5	HH	DN (Nom. diam.)	Weight g/1 piece	Order code*	PN (bar) ¹⁾	
mm	Inch										CF	A3C
6	1/4	M12 1.5	9/16-18UNF	19	19	48.5	36.5	3.5	89	4M12RHZ82EDMLOS	420	400
8, 10	5/16, 3/8	M16 1.5	11/16-16UNF	22	24	56.5	44.5	5.5	156	6M16RHZ82EDMLOS	420	400
12	1/2	M18 1.5	13/16-16UNF	24	27	61.5	49.5	7.5	195	8M18RHZ82EDMLOS	420	400
14, 15, 16	5/8	M22 1.5	1-14UNF	32	36	70.0	56.0	11.5	352	10M22RHZ82EDMLOS	420	315
18, 20	3/4	M27 2.0	1 3/16-12UNF	41	46	77.5	61.5	15.0	608	12M27RHZ82EDMLOS	420	250
22, 25	1	M33 2.0	1 7/16-12UNF	46	50	84.0	66.0	19.0	965	16M33RHZ82EDMLOS	420	250
28, 30, 32	1 1/4	M42 2.0	1 11/16-12UNF	60	60	95.0	75.0	24.0	1396	20M42RHZ82EDMLOS	250	250
35, 38	1 1/2	M48 2.0	2-12UNF	65	70	115.0	93.0	29.0	1978	24M48RHZ82EDMLOS	250	250

¹⁾ Pressure shown = item deliverable

$$\frac{\text{PN (bar)}}{10} = \text{PN (MPa)}$$

Delivery without nut and ring. Information on ordering complete fittings or alternative sealing materials see page 17.

*Please add the **suffixes** below according to the material/ surface required.

Order code suffixes			
Material	Suffix surface and material	Example	Standard sealing material (no additional suffix needed)
Steel, zinc plated., chrome ⁶ -free	CF	4M12RHZ82EDMLOSCF	NBR
Steel, zinc yellow plated	A3C (no suffix needed)	4M12RHZ82EDMLOS	NBR

RHDMTXS Non return valve

Triple-Lok® 37° flare end / Triple-Lok® 37° flare end

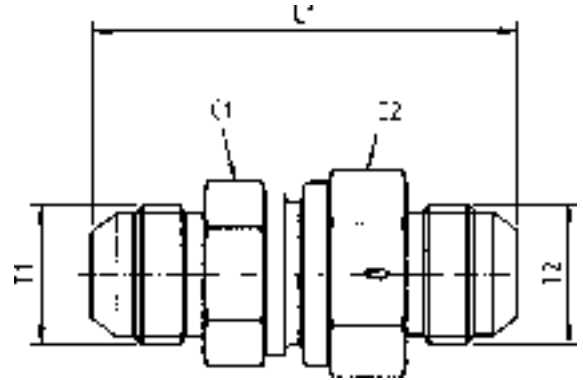

Tube 1 O.D.		Tube 2 O.D.		Thread JIC SAE T1	Thread JIC SAE T2	C1	C2	L1	DN (Nom. diam.)	Weight g/1 piece	Order code*	PN (bar) ¹⁾	
mm	Inch	mm	Inch									CF	A3C
6	1/4	6	1/4	7/16-20UNF	7/16-20UNF	19	19	52.5	3.5	108	4RHDMTXS	420	350
8	5/16	8	5/16	1/2-20UNF	1/2-20UNF	22	24	59.5	5.5	188	5RHDMTXS	420	350
10	3/8	10	3/8	9/16-18UNF	9/16-18UNF	24	27	61.5	7.5	223	6RHDMTXS	420	350
12	1/2	12	1/2	3/4-16UNF	3/4-16UNF	27	32	69.5	9.5	324	8RHDMTXS	420	315
14, 15, 16	5/8	14, 15, 16	5/8	7/8-14UNF	7/8-14UNF	32	36	78.5	11.5	428	10RHDMTXS	350	315
18, 20	3/4	18, 20	3/4	1 1/16-12UN	1 1/16-12UN	41	46	87.5	15.0	731	12RHDMTXS	350	250
25	1	25	1	1 5/16-12UN	1 5/16-12UN	46	50	92.5	19.0	1076	16RHDMTXS	280	250
28, 30, 32	1 1/4	28, 30, 32	1 1/4	1 5/8-12UN	1 5/8-12UN	60	60	105.5	24.0	1630	20RHDMTXS	250	210
35, 38	1 1/2	35, 38	1 1/2	1 7/8-12UN	1 7/8-12UN	65	70	118.5	29.0	2362	24RHDMTXS	210	140

¹⁾ Pressure shown = item deliverable

$$\frac{\text{PN (bar)}}{10} = \text{PN (MPa)}$$

Delivery without nut and ring. Information on ordering complete fittings or alternative sealing materials see page I7.

*Please add the **suffixes** below according to the material/surface required.

Order code suffixes			
Material	Suffix surface and material	Example	Standard sealing material (no additional suffix needed)
Steel, zinc plated., chrome ⁶ -free	CF	4RHDMTXSCF	NBR
Steel, zinc yellow plated	A3C (no suffix needed)	4RHDMTXS	NBR

RHV42EDMXS Non return valve

Male BSPP thread – ED-seal (ISO 1179) / Triple-Lok® 37° flare end

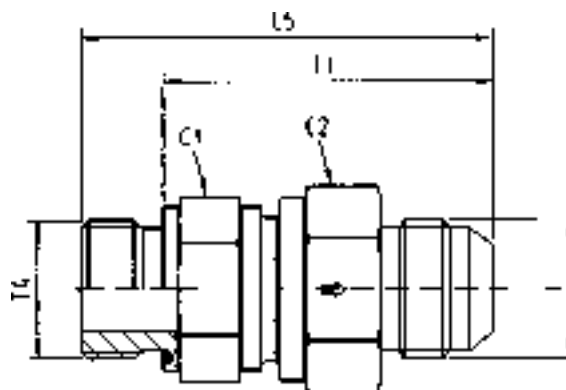

Tube O.D.		BSPP thread T4	Thread JIC SAE T	C1	C2	L5	LL	DN (Nom. diam.)	Weight g/1 piece	Order code*	PN (bar) ¹⁾	
mm	Inch										CF	A3C
6	1/4	G 1/8	7/16-20UNF	19	19	48.0	40.0	3.5	92	4RHV42EDMXS	420	350
8	5/16	G 1/4	1/2-20UNF	22	24	59.5	47.5	5.5	165	5-4RHV42EDMXS	420	350
10	3/8	G 1/4	9/16-18UNF	24	27	62.0	50.0	7.5	191	6RHV42EDMXS	420	350
12	1/2	G 3/8	3/4-16UNF	27	32	67.0	55.0	9.5	277	8RHV42EDMXS	420	315
14, 15, 16	5/8	G 1/2	7/8-14UNS	32	36	76.0	62.0	11.5	366	10RHV42EDMXS	350	315
18, 20	3/4	G 3/4	1 1/16-12UN	41	46	84.5	68.5	15.0	631	12RHV42EDMXS	350	250
25	1	G 1	1 5/16-12UN	46	50	89.5	71.5	19.0	863	16RHV42EDMXS	280	250
28, 30, 32	1 1/4	G 1 1/4	1 5/8-12UN	60	60	102.0	82.0	24.0	1403	20RHV42EDMXS	250	210
35, 38	1 1/2	G 1 1/2	1 7/8-12UN	65	70	113.0	91.0	29.0	1969	24RHV42EDMXS	210	140

¹⁾ Pressure shown = item deliverable

$$\frac{\text{PN (bar)}}{10} = \text{PN (MPa)}$$

Delivery without nut and ring. Information on ordering complete fittings or alternative sealing materials see page I7.

Order code suffixes			
Material	Suffix surface and material	Example	Standard sealing material (no additional suffix needed)
Steel, zinc plated., chrome ⁶ -free	CF	4RHV42EDMXSCF	NBR
Steel, zinc yellow plated	A3C (no suffix needed)	4RHV42EDMXS	NBR

*Please add the **suffixes** below according to the material/surface required.

RHZ42EDMXS Non return valve

Triple-Lok® 37° flare end / Male BSPP thread – ED-seal (ISO 1179)

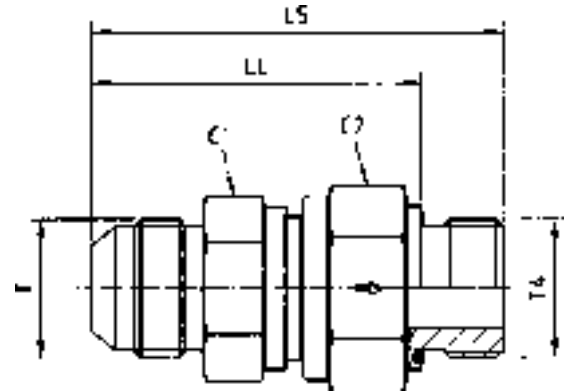

Tube O.D.		BSPP thread T4	Thread JIC SAE T	C1	C2	L5	LL	DN (Nom. diam.)	Weight g/1 piece	Order code*	PN (bar) ¹⁾	
mm	Inch										CF	A3C
6	1/4	G 1/8	7/16-20UNF	19	19	48.0	40.0	3.5	89	4RHZ42EDMXS	420	350
8	5/16	G 1/4	1/2-20UNF	22	24	59.0	47.0	5.5	156	5-4RHZ42EDMXS	420	350
10	3/8	G 1/4	9/16-18UNF	24	27	62.0	50.0	7.5	190	6RHZ42EDMXS	420	350
12	1/2	G 3/8	3/4-16UNF	27	32	66.0	54.0	9.5	278	8RHZ42EDMXS	420	315
14, 15, 16	5/8	G 1/2	7/8-14UNS	32	36	74.0	60.0	11.5	348	10RHZ42EDMXS	350	315
18, 20	3/4	G 3/4	1 1/16-12UN	41	46	82.5	66.5	15.0	634	12RHZ42EDMXS	350	250
25	1	G 1	1 5/16-12UN	46	50	89.5	71.5	19.0	863	16RHZ42EDMXS	280	250
28, 30, 32	1 1/4	G 1 1/4	1 5/8-12UN	60	60	102.0	82.0	24.0	1397	20RHZ42EDMXS	250	210
35, 38	1 1/2	G 1 1/2	1 7/8-12UN	65	70	115.0	93.0	29.0	2001	24RHZ42EDMXS	210	140

¹⁾ Pressure shown = item deliverable

$$\frac{\text{PN (bar)}}{10} = \text{PN (MPa)}$$

Delivery without nut and ring. Information on ordering complete fittings or alternative sealing materials see page 17.

Order code suffixes			
Material	Suffix surface and material	Example	Standard sealing material (no additional suffix needed)
Steel, zinc plated., chrome ⁶ -free	CF	4RHZ42EDMXSCF	NBR
Steel, zinc yellow plated	A3C (no suffix needed)	4RHZ42EDMXS	NBR

*Please add the **suffixes** below according to the material/surface required.

RHV5OMXS Non return valve

Male UN/UNF thread – O-ring (ISO 11926) / Triple-Lok® 37° flare end

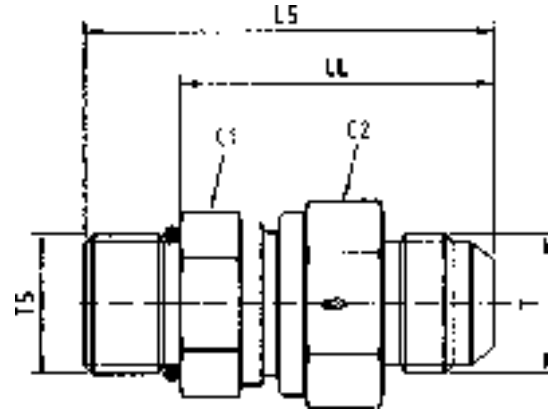

Tube O.D.		Thread UNF T5	Thread JIC SAE T	C1	C2	L5	LL	DN (Nom. diam.)	Weight g/1 piece	Order code*	PN (bar) ¹⁾	
mm	Inch										CF	A3C
6	1/4	7/16-20UNF	7/16-18UNF	19	19	49.5	38.5	3.5	92	4RHV5OMXS	420	350
8	5/16	1/2-20UNF	1/2-20UNF	22	24	56.5	45.5	5.5	165	5RHV5OMXS	420	350
10	3/8	9/16-18UNF	9/16-18UNF	24	27	59.5	47.5	7.5	191	6RHV5OMXS	420	350
12	1/2	3/4-16UNF	3/4-16UNF	27	32	66.5	52.5	9.5	277	8RHV5OMXS	420	315
14, 15, 16	5/8	7/8-14UNS	7/8-14UNS	32	36	75.0	59.0	11.5	366	10RHV5OMXS	350	315
18, 20	3/4	1 1/16-12UN	1 1/16-12UN	41	46	84.0	65.5	15.0	631	12RHV5OMXS	350	250
25	1	1 5/16-12UN	1 5/16-12UN	46	50	88.0	69.5	19.0	863	16RHV5OMXS	280	250
28, 30, 32	1 1/4	1 5/8-12UN	1 5/8-12UN	60	60	99.5	81.0	24.0	1403	20RHV5OMXS	250	210
35, 38	1 1/2	1 7/8-12UN	1 7/8-12UN	65	70	109.5	91.0	29.0	1969	24RHV5OMXS	210	140

¹⁾ Pressure shown = item deliverable

$$\frac{PN \text{ (bar)}}{10} = PN \text{ (MPa)}$$

Delivery without nut and ring. Information on ordering complete fittings or alternative sealing materials see page 17.

*Please add the **suffixes** below according to the material/ surface required.

Order code suffixes			
Material	Suffix surface and material	Example	Standard sealing material (no additional suffix needed)
Steel, zinc plated., chrome ⁶ -free	CF	RHV5OMXSCF	NBR
Steel, zinc yellow plated	A3C (no suffix needed)	4RHV5OMXS	NBR

RHZ50MXS Non return valve

Triple-Lok® 37° flare end / Male UN/UNF thread – O-ring (ISO 11926)

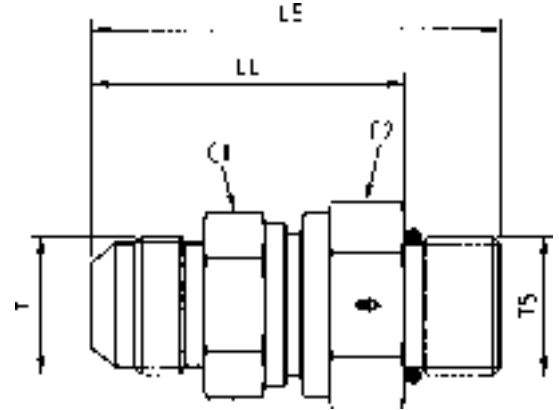

Tube O.D.		Thread UNF T5	Thread JIC SAE T	C1	C2	L5	LL	DN (Nom. diam.)	Weight g/1 piece	Order code*	PN (bar) ¹⁾	
mm	Inch										CF	A3C
6	1/4	7/16-20UNF	7/16-18UNF	19	19	49.5	38.5	3.5	91	4RHZ50MXS	420	350
8	5/16	1/2-20UNF	1/2-20UNF	22	24	56.5	45.5	5.5	161	5RHZ50MXS	420	350
10	3/8	9/16-18UNF	9/16-18UNF	24	27	59.5	47.5	7.5	190	6RHZ50MXS	420	350
12	1/2	3/4-16UNF	3/4-16UNF	27	32	66.5	52.5	9.5	278	8RHZ50MXS	420	315
14, 15, 16	5/8	7/8-14UNS	7/8-14UNS	32	36	75.0	59.0	11.5	348	10RHZ50MXS	350	315
18, 20	3/4	1 1/16-12UN	1 1/16-12UN	41	46	84.0	65.5	15.0	634	12RHZ50MXS	350	250
25	1	1 5/16-12UN	1 5/16-12UN	46	50	88.0	69.5	19.0	863	16RHZ50MXS	280	250
28, 30, 32	1 1/4	1 5/8-12UN	1 5/8-12UN	60	60	99.5	81.0	24.0	1397	20RHZ50MXS	250	210
35, 38	1 1/2	1 7/8-12UN	1 7/8-12UN	65	70	109.5	81.0	29.0	2001	24RHZ50MXS	210	240

¹⁾ Pressure shown = item deliverable

$$\frac{\text{PN (bar)}}{10} = \text{PN (MPa)}$$

Delivery without nut and ring. Information on ordering complete fittings or alternative sealing materials see page 17.

*Please add the **suffixes** below according to the material/surface required.

Order code suffixes			
Material	Suffix surface and material	Example	Standard sealing material (no additional suffix needed)
Steel, zinc plated., chrome ⁶ -free	CF	4RHZ50MXSCF	NBR
Steel, zinc yellow plated	A3C (no suffix needed)	4RHZ50MXS	NBR

RHV82EDMXS Non return valve

Male metric thread – ED-seal (ISO 9974) / Triple-Lok® 37° flare end

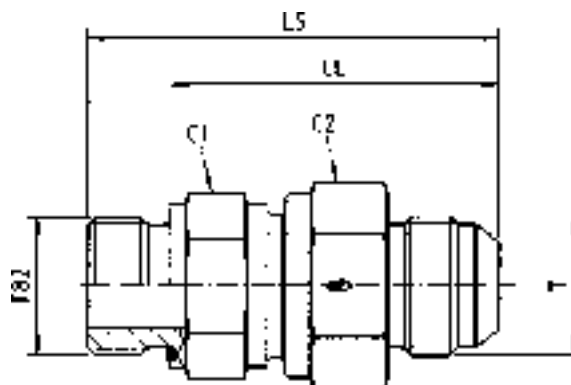

Tube O.D.		Metric thread T82	Thread JIC SAE T	C1	C2	L5	LL	DN (Nom. diam.)	Weight g/1 piece	Order code*	PN (bar) ¹⁾	
mm	Inch										CF	A3C
6	1/4	M10 1.0	7/16-20UNF	19	19	48.0	40.0	3.5	89	4M10RHV82EDMXS	420	350
8	5/16	M12 1.5	1/2-20UNF	22	24	59.5	47.5	5.5	157	5M12RHV82EDMXS	420	350
10	3/8	M14 1.5	9/16-18UNF	24	27	62.0	50.0	7.5	195	6M14RHV82EDMXS	420	350
12	1/2	M16 1.5	3/4-16UNF	27	32	67.0	55.0	9.5	274	8M16RHV82EDMXS	420	315
14, 15, 16	5/8	M18 1.5	7/8-14UNS	32	36	73.5	61.5	11.5	369	10M18RHV82EDMXS	350	315
18, 20	3/4	M27 2.0	1 1/16-12UN	41	46	84.5	68.5	15.0	628	12M27RHV82EDMXS	350	160
25	1	M33 2.0	1 5/16-12UN	46	50	89.5	71.5	19.0	867	16M33RHV82EDMXS	280	250
28, 30, 32	1 1/4	M42 2.0	1 5/8-12UN	60	60	102.0	82.0	24.0	1409	20M42RHV82EDMXS	250	210
35, 38	1 1/2	M48 2.0	1 7/8-12UN	65	70	113.0	91.0	29.0	1970	24M48RHV82EDMXS	210	140

¹⁾ Pressure shown = item deliverable

$$\frac{\text{PN (bar)}}{10} = \text{PN (MPa)}$$

Delivery without nut and ring. Information on ordering complete fittings or alternative sealing materials see page I7.

*Please add the **suffixes** below according to the material/surface required.

Order code suffixes			
Material	Suffix surface and material	Example	Standard sealing material (no additional suffix needed)
Steel, zinc plated., chrome ⁶ -free	CF	4M10RHV82EDMXSCF	NBR
Steel, zinc yellow plated	A3C (no suffix needed)	4M10RHV82EDMXS	NBR

RHZ82EDMXS Non return valve

Triple-Lok® 37° flare end / Male metric thread – ED-seal (ISO 9974)

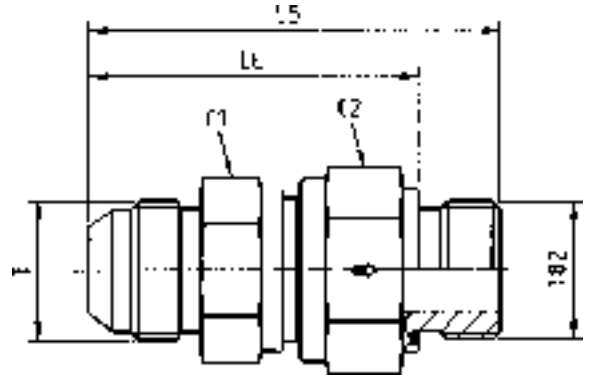

Tube O.D.		Metric thread T82	Thread JIC SAE T	C1	C2	L5	LL	DN (Nom. diam.)	Weight g/1 piece	Order code*	PN (bar) ¹⁾	
mm	Inch										CF	A3C
6	1/4	M10×1.0	7/16-20UNF	19	19	48.0	40.0	3.5	89	4M10RHZ82EDMXS	420	350
8	5/16	M12×1.5	1/2-20UNF	22	24	59.5	47.5	5.5	156	5M12RHZ82EDMXS	420	350
10	3/8	M14×1.5	9/16-18UNF	24	27	62.0	50.0	7.5	195	6M14RHZ82EDMXS	420	350
12	1/2	M16×1.5	3/4-16UNF	27	32	66.0	54.0	9.5	272	8M16RHZ82EDMXS	420	315
14, 15, 16	5/8	M18×1.5	7/8-14UNS	32	36	71.5	59.5	11.5	352	10M18RHZ82EDMXS	350	315
18, 20	3/4	M27×2.0	1 1/16-12UN	41	46	82.5	66.5	15.0	608	12M27RHZ82EDMXS	350	250
25	1	M33×2.0	1 5/16-12UN	46	50	89.5	71.5	19.0	965	16M33RHZ82EDMXS	280	250
28, 30, 32	1 1/4	M42×2.0	1 5/8-12UN	60	60	102.0	82.0	24.0	1396	20M42RHZ82EDMXS	250	210
35, 38	1 1/2	M48×2.0	1 7/8-12UN	65	70	115.0	93.0	29.0	1807	24M48RHZ82EDMXS	210	140

¹⁾ Pressure shown = item deliverable

$$\frac{\text{PN (bar)}}{10} = \text{PN (MPa)}$$

Delivery without nut and ring. Information on ordering complete fittings or alternative sealing materials see page I7.

*Please add the **suffixes** below according to the material/surface required.

Order code suffixes			
Material	Suffix surface and material	Example	Standard sealing material (no additional suffix needed)
Steel, zinc plated., chrome ⁶ -free	CF	4M10RHZ82EDMXSCF	NBR
Steel, zinc yellow plated	A3C (no suffix needed)	4M10RHZ82EDMXS	NBR

DV Shut-off valve PN 10 – Casing DIN 3512

EO 24° cone end / EO 24° cone end

(with internal threaded spindle)

For cold and warm water* up to 80°C, compressed air, mineral oils and fuel oils types EL and L, 6 bar and up to 80°C.

The pressure specification PN for hand-operated

shut-off valves applies to the design

factor 1,5 (according DIN 3230 T5

and ISO 5208).

Caution!

Please note the admissible pressure ratings for the EO-tube ends.

DVAE

EO tube end ← male BSPP

DVAA

male BSPP ← EO tube end

DV-valves with male BSPP thread on request.

*Indicate type of water or additive if any

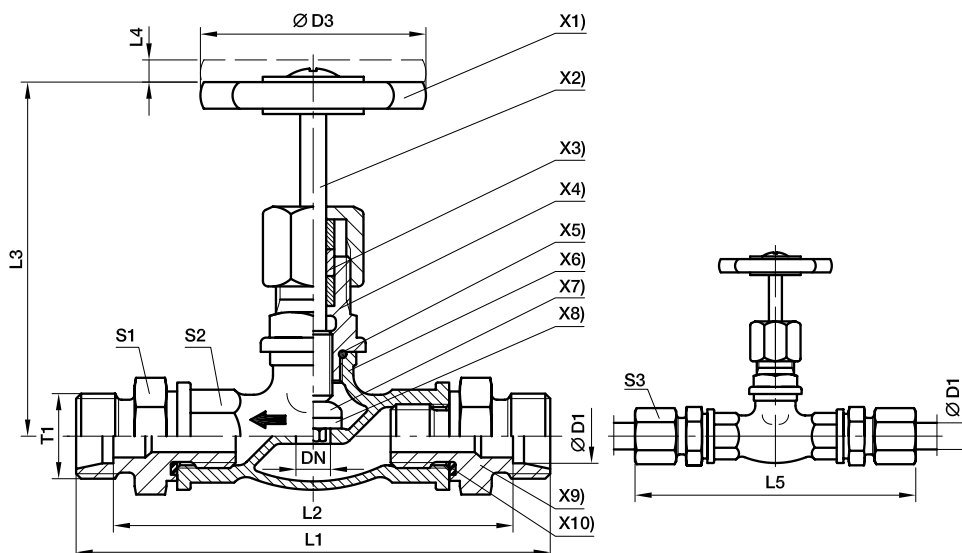

- X1) **Hand wheel:** material: Polyamid
- X2) **Spindle:** material: Brass 2.0401
- X3) **Stuffing boxpacking:** PTFE (e.g. Teflon) Compound
- X4) **Head piece:** material: Brass 2.0401
- X5) **Sealing:** O-ring NBR (e.g. Perbunan)
- X6) **Casing:** material: Brass 2.0340.02
- X7) **Valve cone:** material: Brass 2.0401
- X8) **Shut-off sealing:** NBR (e.g. Perbunan)
- X9) **Male stud fitting:** material: Brass 2.0540
- X10) **Sealing:** Eolastic-sealing NBR (e.g. Perbunan)

Series	D1	T1	DN	D3	L1	L2	L3	L4	L5	S1	S2	S3	Weight g/1 piece	Order code*	PN (bar) ¹⁾ without surface
L ³⁾	06	M 12×1.5	5	50	102	88	63	7	117	22	21	14	313	DV06LX	10
	08	M 14×1.5	6	50	102	88	63	7	117	22	21	17	305	DV08LX	10
	10	M 16×1.5	8	50	104	90	63	7	119	22	21	19	308	DV10LX	10
	12	M 18×1.5	10	50	104	90	63	7	119	22	21	22	304	DV12LX	10
	15	M 22×1.5	12	50	107	93	65	8	123	27	25	27	426	DV15LX	10
	18	M 26×1.5	16	50	109	94	67	8	126	27	25	32	434	DV18LX	10
	22	M 30×2	20	60	123	108	67	8	140	32	32	36	670	DV22LX	10
	28	M 36×2	25	60	140	125	95	10	158	41	38	41	1030	DV28LX	10
	35	M 45×2	32	70	166	145	102	10	188	50	47	50	1640	DV35LX	10

¹⁾ Pressure shown = item deliverable

³⁾ L = light series

$$\frac{PN \text{ (bar)}}{10} = PN \text{ (MPa)}$$

Delivery without nut and ring. Information on ordering complete fittings or alternative sealing materials see page I7.

*Please add the **suffixes** below according to the material/surface required.

Order code suffixes			
Material	Suffix surface and material	Example	Standard sealing material (no additional suffix needed)
Brass 2.0340.02	without	DV06LX	PTFE / NBR

LD Shut-off valve PN 40

EO 24° cone end / EO 24° cone end

(with internal threaded spindle)

For hydraulic oil, mineral, oil, fuel oil, Diesel, water* etc. Temperature up to 150°C. For steam up to 10 bar.

For compressed air up to 35 bar on request. CS DIN 86501 Rg.-N.

The pressure specification PN for hand-operated shut-off valves applies to the design factor 1,5 (according to DIN 3230 T5 and ISO 5208).

Caution!

Please note the admissible pressure ratings for the EO-tube ends.

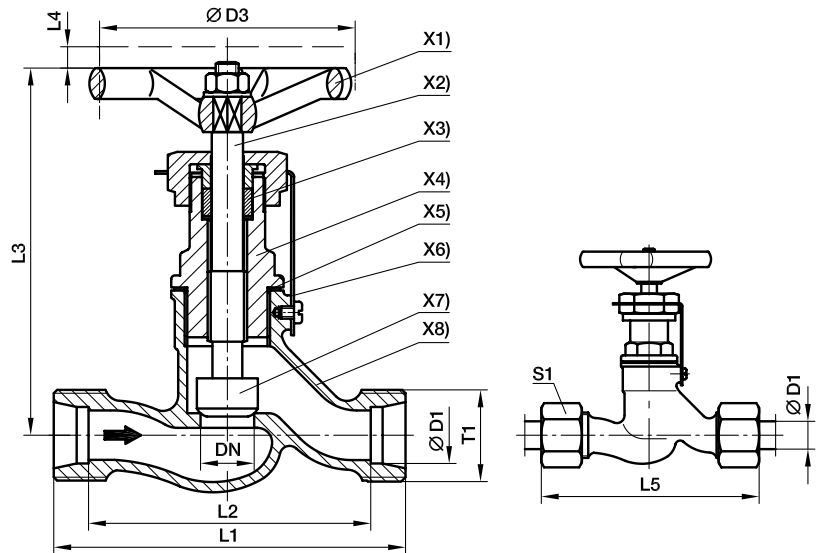

- X1) **Hand wheel:** Plastic material typ 74 according to DIN 388 Form C
- X2) **Spindle:** with internal thread. Material: Cu Zn 35 Ni 2
- X3) **Stuffing box packing:** Graphite
- X4) **Head piece:** material: Cu Zn 39 Pb 3
- X5) **Sealing:** Copper ring
- X6) **Locking plates:** material: St. 37/zinc plated
- X7) **Valve cone:** loose tip material: Cu Zn 35 Ni 2
- X8) **Casing:** material: G-Cu Sn 5Zn Pb (Rg 5 according to DIN 1705)

EO-tube connection:

for **copper** tubes nuts, cutting and locking rings of brass

Attention:

for **steel** tubes: nuts, progressive rings of steel

specify when ordering

We recommend pre-installation in hardened pre-installation body (see assembly instructions)

Series	D1	T1	DN	D3	L1	L2	L3	L4	L5	S1	Weight g/1 piece	Order code*	PN (bar) ¹⁾ without surface
S ⁴⁾	10	M18×1.5	6	63	60	45	98	7	77	22	383	LD10SX	40
	12	M20×1.5	8	63	64	49	98	7	81	24	401	LD12SX	40
	14	M22×1,5	10	63	70	54	98	7	89	27	417	LD14SX	40
	16	M24×1.5	12	80	84	67	110	9	103	30	631	LD16SX	40
	20	M30×2	16	80	90	69	110	9	112	36	688	LD20SX	40
	25	M36×2	20	100	110	86	129	12	134	46	1191	LD25SX	40
	30	M42×2	25	100	120	93	129	12	146	50	1322	LD30SX	40
	38	M52×2	32	100	140	108	158	12	169	60	2268	LD38SX	40

¹⁾ Pressure shown = item deliverable

⁴⁾ S = heavy series

$$\frac{\text{PN (bar)}}{10} = \text{PN (MPa)}$$

Delivery without nut and ring. Information on ordering complete fittings or alternative sealing materials see page 17.

*Please add the **suffixes** below according to the material/surface required.

Order code suffixes			
Material	Suffix surface and material	Example	Standard sealing material (no additional. suffix needed)
Gunmetal (Rg 5) 2.1096	without	LD10SX	Graphit / Metal

WV Alternating valve

EO 24° cone end / EO 24° cone end / EQ 24° cone end

These valves permit the passage of flow from either inlet 1 or 2 to the outlet port whilst shutting of the inlet port not in use. The shutting off, of an inlet is achieved by a floating ball bearing which moves by the pressure of the flow.

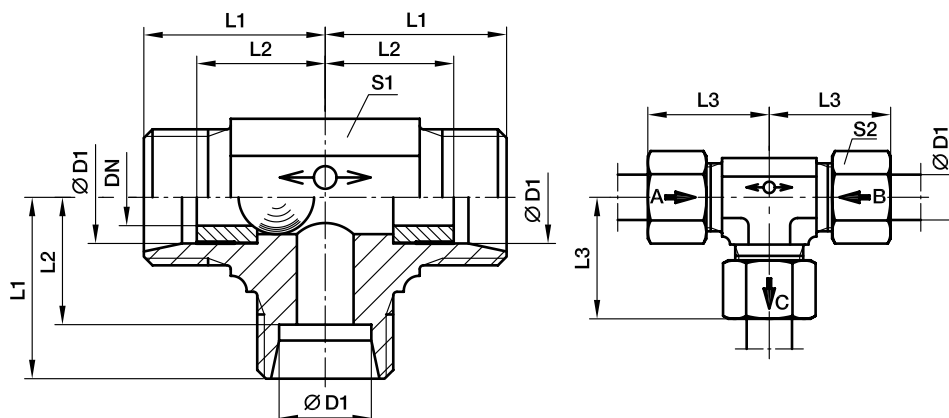

Material: steel
Surface finish: Zinc plated and yellow chromated (A3C).

Valves are not recommended for compressed air and gases.
WV-valves are not to be used in connection with weld nipples, swivel nuts etc. where there is no contact with a shoulder stop in the inner cone.

Temperature range without pressure reductions: -40°C up to +120°C.

Recommended fitting position as shown in the picture.

Leakage rate for alternating valves (hydraulic test with test pressure = P_{max}): approx. 20 drops (test period of 1 minute).

Directions of flow:

$D_1 \rightarrow D_3 = D_2$ closed
 $D_2 \rightarrow D_3 = D_1$ closed

Series	D1	T1	DN	L1	L2	L3	S1	S2	Weight g/1 piece	Order code*	PN (bar) ¹⁾	
											CF	A3C
L ³⁾	8	M 14×1.5	4,5	21	14	29	14	17	53	WV08LOMD	160	160
	10	M 16×1.5	6,0	22	15	30	17	19	73	WV10LOMD	160	160
	12	M 18×1.5	7,5	24	17	32	19	22	96	WV12LOMD	160	160
	15	M 22×1.5	10,0	28	21	36	19	27	134	WV15LOMD	160	160

¹⁾ Pressure shown = item deliverable

³⁾ L = light series

$\frac{PN \text{ (bar)}}{10} = PN \text{ (MPa)}$

Delivery without nut and ring. Information on ordering complete fittings or alternative sealing materials see page 17.

*Please add the **suffixes** below according to the material/surface required.

Order code suffixes			
Material	Suffix surface and material	Example	Standard sealing material (no additional suffix needed)
Steel, zinc plated., chrome ⁶ -free	CF	WV08LOMDCF	Steel ball
Steel, zinc yellow plated	A3C	WV08LOMDA3C	Steel ball

KH 2-way ball valve steel

EO 24° cone end / EO 24° cone end

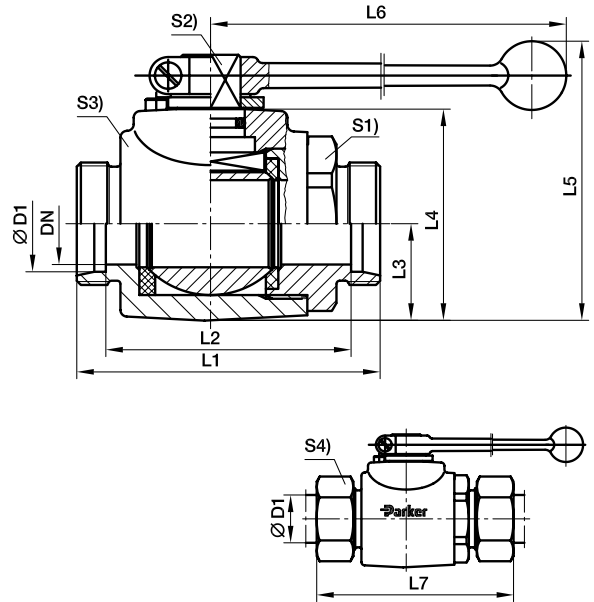
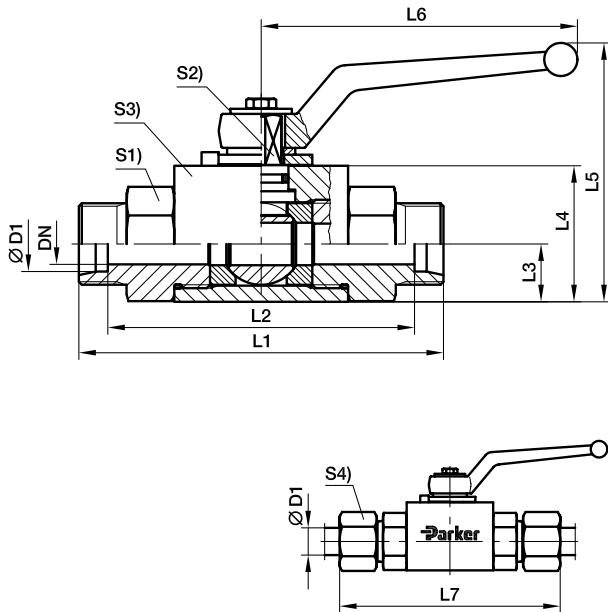

Series	D1 DN	L1	L2	L3	L4	L5	L6	L7	S1	S2	S3	S4	Weight g/1 piece	Order code*	PN (bar) ¹⁾ bronzed		
L ³⁾	06	4	67	53	10.0	25	55.0	76	82	19	7	20	14	195	KH06LX	500	
	08	6	67	53	10.0	25	55.0	76	82	19	7	20	17	190	KH08LX	500	
	10	8	75	61	14.5	35	68.0	100	90	24	8	30	19	420	KH10LX	500	
	12	10	75	61	14.5	35	68.0	100	90	24	8	30	22	410	KH12LX	500	
	15	12	83	69	17.0	40	92.0	112	99	30	10	35	27	631	KH15LX	500	
	18	16	82	67	20.0	45	105.0	166	99	36	11	45	32	850	KH18LX	400	
	22	20	99	84	24.0	55	113.0	187	116	41	14	45	36	1210	KH22LX	400	
	28	25	108	93	26.0	60	118.0	187	126	50	14	55	41	1750	KH28LX	400	
	35	25	116	95	26.0	60	118.0	187	138	50	14	55	50	1820	KH35LXDN25	400	
	35	32	121	100	36.5	80	180.5	320	143	60	17	73	50	3158	KH35LX	315	
	42	25	121	99	26.0	60	118.0	187	144	55	14	55	60	1940	KH42LXDN25	400	
	42	40	118	96	42.5	90	190.5	320	141	70	17	85	60	3788	KH42LX	315	
	S ⁴⁾	08	4	73	59	10.0	25	55.0	76	88	19	7	20	19	214	KH08SX	500
		10	6	73	58	10.0	25	55.0	76	90	19	7	20	22	220	KH10SX	500
12		8	77	62	14.5	35	68.0	100	94	24	8	30	24	430	KH12SX	500	
14		10	81	65	14.5	35	68.0	100	100	24	8	30	27	440	KH14SX	500	
16		12	87	70	17.0	40	92.0	112	106	30	10	35	30	649	KH16SX	500	
20		16	90	69	20.0	45	105.0	166	112	36	11	45	36	900	KH20SX	400	
25		20	107	83	24.0	55	113.0	187	131	41	14	45	46	1290	KH25SX	400	
30		25	120	93	26.0	60	118.0	187	146	50	14	55	50	1880	KH30SX	400	
38		25	134	102	26.0	60	118.0	187	163	55	14	55	60	1950	KH38SXDN25	400	
38		32	127	95	36.5	80	180.5	320	156	60	17	73	60	3266	KH38SX	315	

¹⁾ Pressure shown = item deliverable

³⁾ L = light series; ⁴⁾ S = heavy series

$$\frac{\text{PN (bar)}}{10} = \text{PN (MPa)}$$

Delivery without nut and ring. Information on ordering complete fittings or alternative sealing materials see page 17.

*Please add the **suffixes** below according to the material/surface required.

Order code suffixes			
Material	Suffix surface and material	Example	Standard sealing material (no additional suffix needed)
Steel, bronzed	DIN 50938-FE//A/T4	KH06LX	POM / NBR

KH 2-way ball valve stainless steel

EO 24° cone end / EO 24° cone end

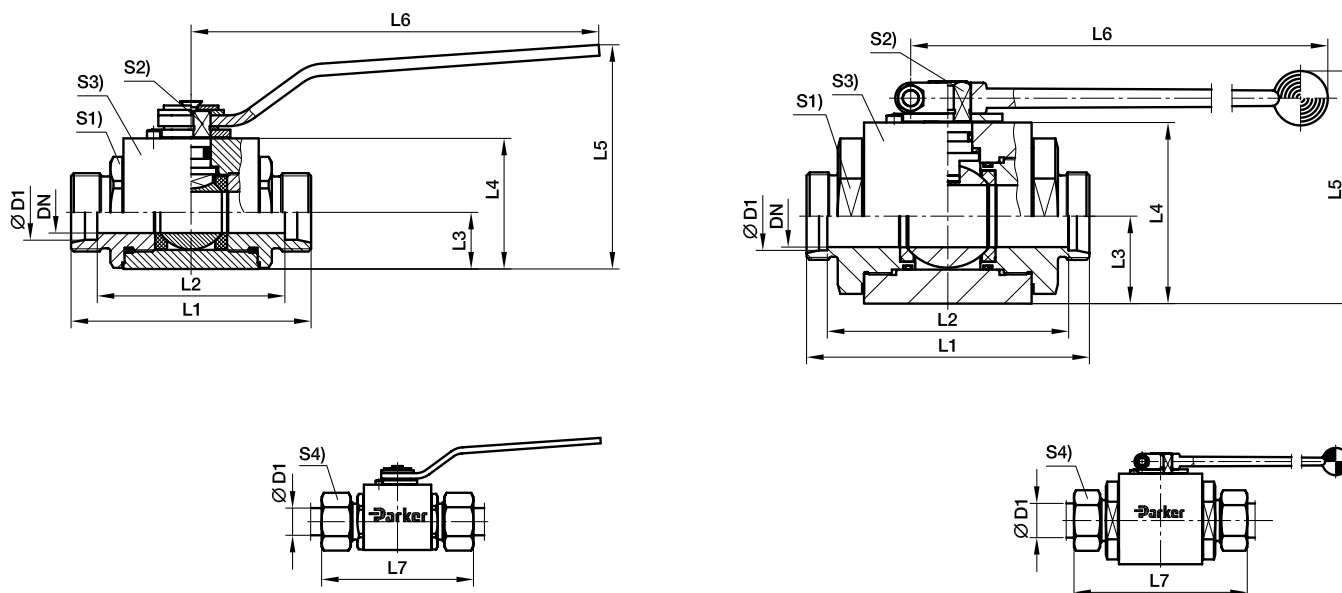

Series	D1 DN	L1	L2	L3	L4	L5	L6	L7	S1	S2	S3	S4	Weight g/1 piece	Order code*	PN (bar) ¹⁾ 71	
L ³⁾	06	4	73	59	13.7	30.0	55	76	88	22	7	30	14	383	KH06L71X	500
	08	6	73	59	13.7	30.0	55	76	88	22	7	30	17	381	KH08L71X	500
	10	8	87	73	18.0	40.0	85	130	102	30	8	40	19	809	KH10L71X	500
	12	10	87	73	18.0	40.0	85	130	102	30	8	40	22	821	KH12L71X	500
	15	12	91	77	21.0	45.0	90	130	107	32	10	45	27	1020	KH15L71X	500
	18	16	91	76	21.0	45.0	90	130	108	32	10	45	32	1037	KH18L71X	500
	22	20	102	87	26.0	60.0	103	187	119	46	14	50	36	1610	KH22L71X	315
	28	25	107	92	28.0	65.0	108	187	125	50	14	55	41	2032	KH28L71X	315
	35	32	126	105	45.0	93.2	174	320	148	70	19	100	50	4780	KH35L71X	420
	42	40	136	114	52.5	104.4	185	320	159	80	19	110	60	7754	KH42L71X	420
S ⁴⁾	08	4	76	62	13.7	30.0	55	76	91	22	7	30	19	392	KH08S71X	500
	10	6	76	61	13.7	30.0	55	76	93	22	7	30	22	460	KH10S71X	500
	12	8	89	74	18.0	40.0	85	130	106	30	8	40	24	840	KH12S71X	500
	14	10	93	77	18.0	40.0	85	130	112	30	8	40	27	847	KH14S71X	500
	16	12	96	79	21.0	45.0	90	130	115	32	10	45	30	1055	KH16S71X	500
	20	16	99	78	21.0	45.0	90	130	121	32	10	45	36	1079	KH20S71X	500
	25	20	110	86	26.0	60.0	103	187	134	46	14	50	46	1720	KH25S71X	315
	30	25	120	93	28.0	65.0	108	187	146	50	14	55	50	2150	KH30S71X	315
	38	32	132	100	45.0	93.2	174	320	161	70	19	100	60	6066	KH38S71X	420

1) Pressure shown = item deliverable

3) L = light series; 4) S = heavy series

$$\frac{PN \text{ (bar)}}{10} = PN \text{ (MPa)}$$

Delivery without nut and ring. Information on ordering complete fittings or alternative sealing materials see page 17.

*Please add the **suffixes** below according to the material/surface required.

Order code suffixes			
Material	Suffix surface and material	Example	Standard sealing material (no additional suffix needed)
Stainless Steel	without	KH06L71X	POM / NBR

KH 2-way BSPP ball valve steel

Female BSPP thread (ISO 1179-1) / Female BSPP thread (ISO 1179-1)

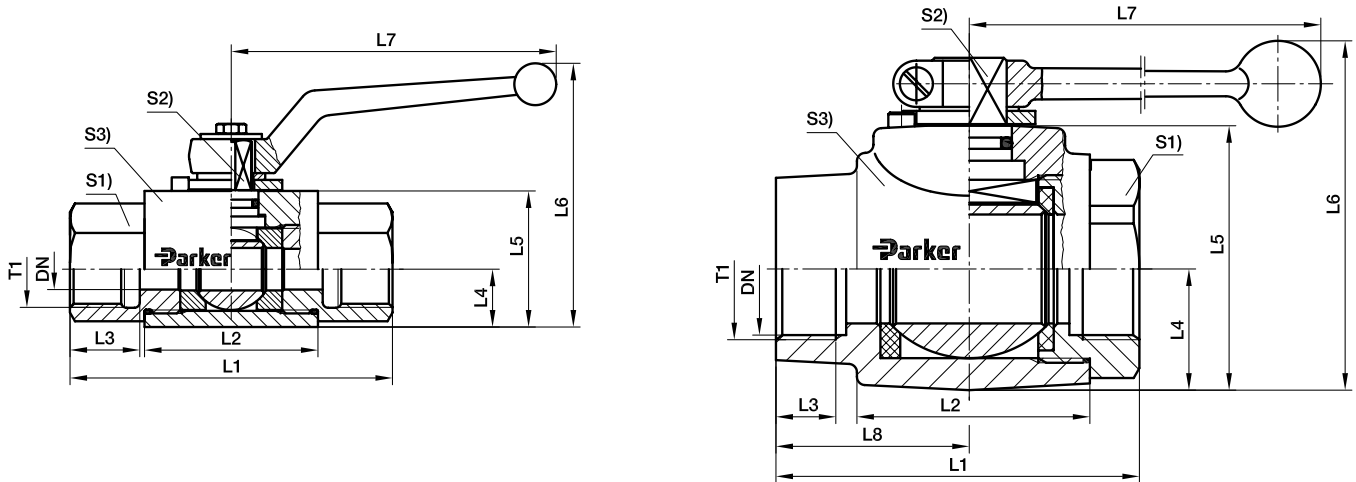

T1	DN	L1	L2	L3	L4	L5	L6	L7	L8	S1	S2	S3	Weight g/1 piece	Order code*	PN (bar) ¹⁾ 71
G 1/8	4	69	36	12	10.0	25	55.0	76	-	19	7	20	220	KH1/8X	500
G 1/4	6	69	36	12	10.0	25	55.0	76	-	19	7	20	210	KH1/4X	500
G 3/8	10	73	45	14	14.5	35	68.0	100	-	24	8	30	430	KH3/8X	500
G 1/2	12	82	51	15	17.0	40	92.0	112	-	30	10	35	670	KH1/2X	500
G 5/8	16	88	50	18	20.0	45	105.0	166	-	36	11	45	973	KH5/8X	400
G 3/4	20	93	60	18	24.0	55	113.0	187	-	41	14	45	1280	KH3/4X	400
G 1	25	113	70	20	26.0	60	118.0	187	-	50	14	55	1982	KH1X	400
G 1 1/4	32	110	70	20	36.5	80	180.5	320	58.5	60	17	73	2620	KH11/4X	315
G 1 1/4	25	134	70	20	26.0	60	118.0	187	-	50	14	55	2066	KH11/4DN25X	400
G 1 1/2	40	114	75	22	42.5	90	190.5	320	57.0	70	17	85	3989	KH11/2X	315
G 1 1/2	25	139	70	22	26.0	60	118.0	187	-	55	14	55	2200	KH11/2DN25X	400

¹⁾ Pressure shown = item deliverable

$$\frac{\text{PN (bar)}}{10} = \text{PN (MPa)}$$

Delivery without nut and ring. Information on ordering complete fittings or alternative sealing materials see page 17.

*Please add the **suffixes** below according to the material/surface required.

Order code suffixes			
Material	Suffix surface and material	Example	Standard sealing material (no additional suffix needed)
Steel, bronzed	DIN 50938-FE//A/T4	KH1/8X	POM / NBR

KH 2-way BSPP ball valve stainless steel

Female BSPP thread (ISO 1179-1) / Female BSPP thread (ISO 1179-1)

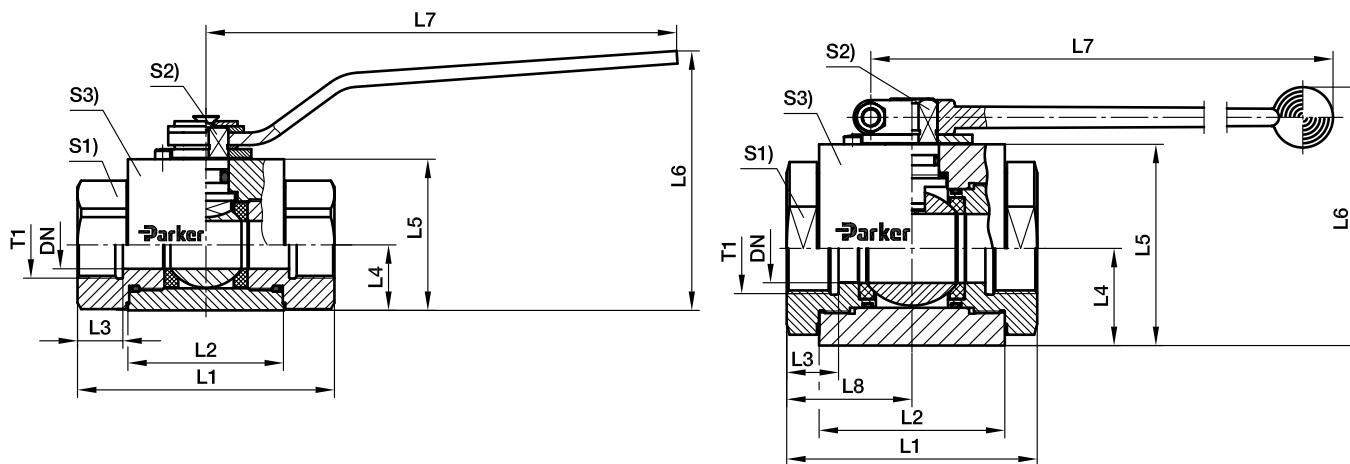

T1	DN	L1	L2	L3	L4	L5	L6	L7	L8	S1	S2	S3	Weight g/1 piece	Order code*	PN (bar) ¹⁾ 71
G 1/8	4	69	41	11	13.7	30.0	55	76	-	22	7	30	421	KH1/871x	500
G 1/4	6	75	41	14	13.7	30.0	55	76	-	22	7	30	422	KH1/471x	500
G 3/8	10	86	53	14	18.0	40.0	85	130	-	30	8	40	891	KH3/871x	500
G 1/2	12	92	55	16	21.0	45.0	90	130	-	32	10	45	1093	KH1/271x	500
G 3/4	20	102	62	18	26.0	60.0	103	187	-	46	14	50	1944	KH3/471x	315
G 1	25	112	67	20	28.0	65.0	108	187	-	50	14	55	2200	KH171x	315
G 1 1/4	32	116	86	24	45.0	93.2	174	320	58	70	19	100	5300	KH11/471x	420
G 1 1/2	40	120	92	26	52.2	104.5	185	320	60	80	19	110	7230	KH11/271x	420

¹⁾ Pressure shown = item deliverable

$$\frac{\text{PN (bar)}}{10} = \text{PN (MPa)}$$

Delivery without nut and ring. Information on ordering complete fittings or alternative sealing materials see page 17.

*Please add the **suffixes** below according to the material/surface required.

Order code suffixes			
Material	Suffix surface and material	Example	Standard sealing material (no additional suffix needed)
Stainless Steel	without	KH1/871X	POM / NBR

KH 2-way NPT ball valve steel

Female NPT thread (SAE 476) / Female NPT thread (SAE 476)

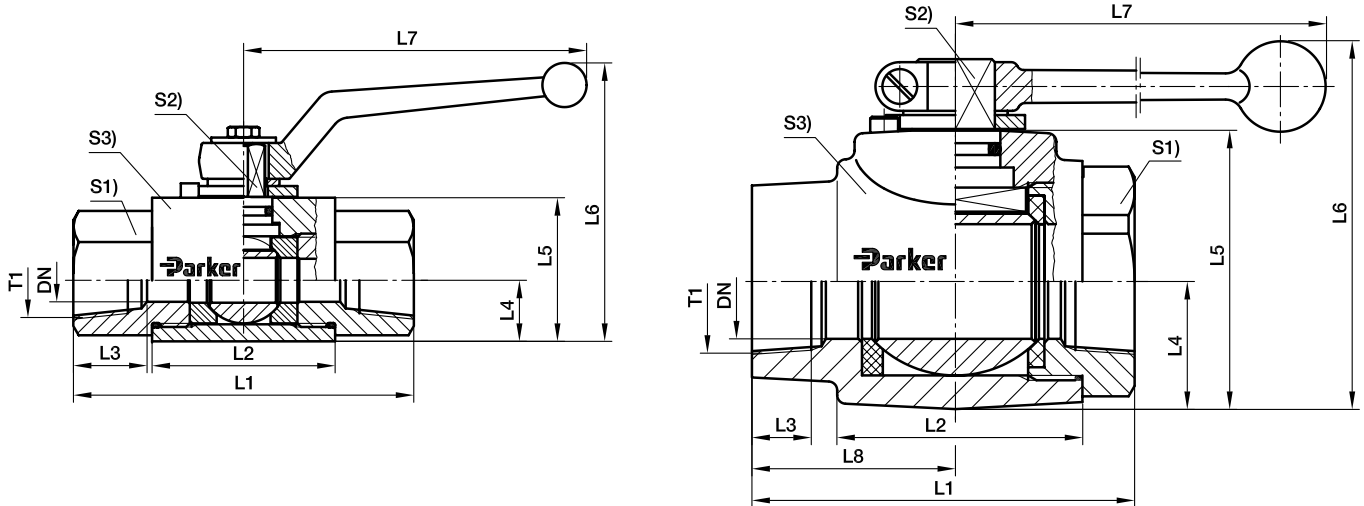

T1	DN	L1	L2	L3	L4	L5	L6	L7	L8	S1	S2	S3	Weight g/1 piece	Order code*	PN (bar) ¹⁾ bronzed
1/8-27 NPT	4	69	36	7.0	10.0	25	55.0	76		19	7	20	225	KH1/8NPTX	500
1/4-18 NPT	6	69	36	10.0	10.0	25	55.0	76		19	7	20	210	KH1/4NPTX	500
3/8-18 NPT	10	73	45	10.4	14.5	35	68.0	100		24	8	30	430	KH3/8NPTX	500
1/2-14 NPT	12	82	51	13.6	17.0	40	92.0	112		30	10	35	670	KH1/2NPTX	500
3/4-14 NPT	20	93	60	14.0	24.0	55	113.0	187		41	14	45	1280	KH3/4NPTX	400
1-11 1/2 NPT	25	113	70	16.8	26.0	60	118.0	187		50	14	55	1970	KH1NPTX	400
1 1/4-11 1/2 NPT	32	110	70	17.3	36.5	80	180.5	320	58.5	60	17	73	3074	KH11/4NPTX	315
1 1/2-11 1/2 NPT	40	114	75	17.3	42.5	90	190.5	320	57.0	70	17	85	3976	KH11/2NPTX	315

¹⁾ Pressure shown = item deliverable

$$\frac{\text{PN (bar)}}{10} = \text{PN (MPa)}$$

Delivery without nut and ring. Information on ordering complete fittings or alternative sealing materials see page 17.

*Please add the **suffixes** below according to the material/surface required.

Order code suffixes			
Material	Suffix surface and material	Example	Standard sealing material (no additional suffix needed)
Steel, bronzed	DIN 50938-FE//A/T4	KH1/8NPTX	POM / NBR

KH 2-way NPT ball valve stainless steel

Female NPT thread (SAE 476) / Female NPT thread (SAE 476)

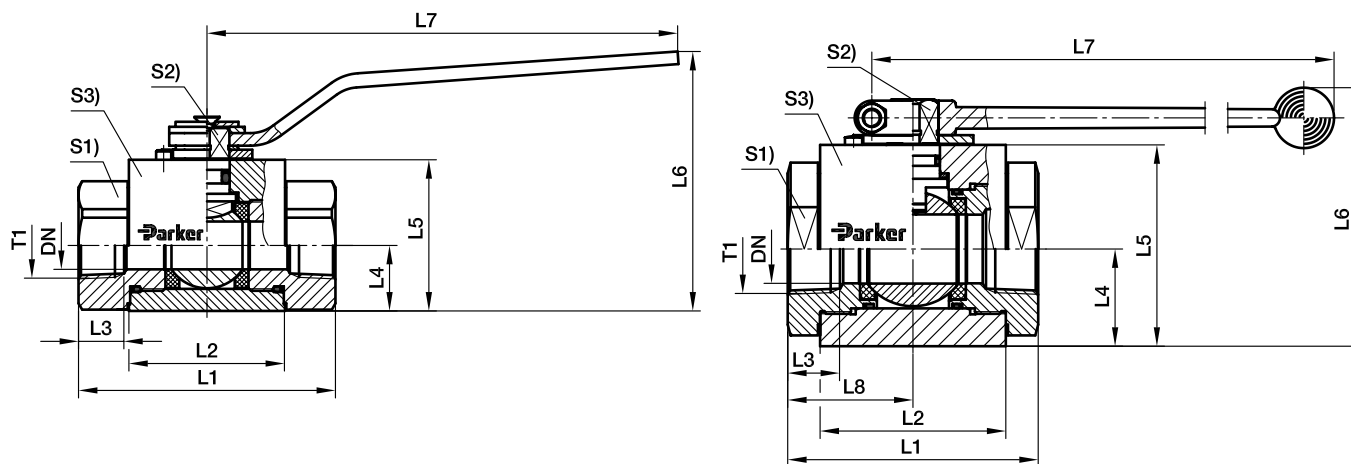

T1	DN	L1	L2	L3	L4	L5	L6	L7	L8	S1	S2	S3	Weight g/1 piece	Order code*	PN (bar) ¹⁾ bronzed
1/8-27 NPT	4	72	41	6.9	13.7	30.0	55	76		22	7	30	461	KH1/8NPT71X	500
1/4-18 NPT	6	82	41	10.0	13.7	30.0	55	76		22	7	30	441	KH1/4NPT71X	500
3/8-18 NPT	10	95	53	10.3	18.0	40.0	85	130		30	8	40	943	KH3/8NPT71X	500
1/2-14 NPT	12	108	55	13.6	21.0	45.0	90	130		32	10	45	1177	KH1/2NPT71X	500
3/4-14 NPT	20	112	62	14.1	26.0	60.0	103	187		46	14	50	2054	KH3/4NPT71X	315
1-11 1/2 NPT	25	126	67	16.8	28.0	65.0	108	187		50	14	55	2451	KH1NPT71X	315
11/4-11 1/2 NPT	32	116	86	17.3	45.0	93.2	174	320	58	70	18	100	5300	KH11/4NPT71X	420
11/2-11 1/2 NPT	40	120	92	17.3	52.2	104.4	185	320	60	80	19	110	7230	KH11/2NPT71X	420

¹⁾ Pressure shown = item deliverable

$$\frac{\text{PN (bar)}}{10} = \text{PN (MPa)}$$

Delivery without nut and ring. Information on ordering complete fittings or alternative sealing materials see page I7.

*Please add the **suffixes** below according to the material/surface required.

Order code suffixes			
Material	Suffix surface and material	Example	Standard sealing material (no additional suffix needed)
Steel, bronzed	DIN 50938-FE//A/T4	KH1/8NPT71X	POM / NBR

KH 3-way compact ball valve steel

EO 24° cone end / EO 24° cone end / EO 24° cone end

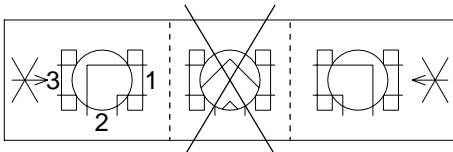
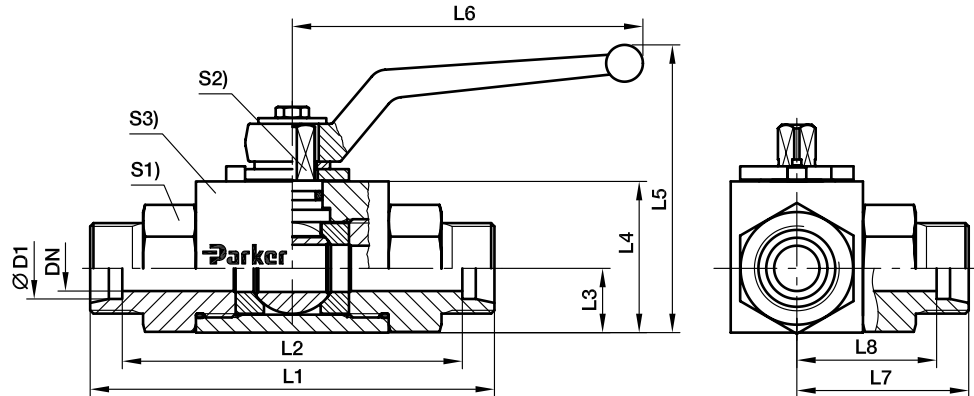

L-Version

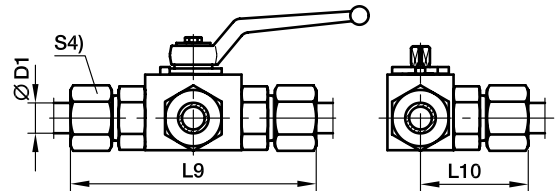

Series	D1	DN	L1	L2	L3	L4	L5	L6	L7	L8	L9	L10	S1	S2	S3	S4	Weight g/1 piece	Order code*	PN (bar) ¹⁾ bronzed
L ³⁾	06	4	67	53	15.0	30	59.5	76	33.5	26.5	82	41.0	19	7	30	14	317	KH3/2-06LX	500
	08	6	67	53	15.0	30	59.5	76	33.5	26.5	82	41.0	19	7	30	17	214	KH3/2-08LX	500
	10	8	75	61	14.5	35	67.5	100	37.5	30.5	90	45.0	24	8	40	19	445	KH3/2-10LX	500
	12	10	75	61	14.5	35	67.5	100	37.5	30.5	90	45.0	24	8	40	22	537	KH3/2-12LX	500
	15	12	83	69	22.0	45	96.5	112	41.5	34.5	99	49.5	30	10	45	27	678	KH3/2-15LX	500
	18	16	82	67	25.0	50	110.0	166	41	33.5	99	49.5	36	11	50	32	850	KH3/2-18LX	400
	22	20	99	84	29.0	60	126.0	187	49.5	42.0	116	58.0	41	14	55	36	1340	KH3/2-22LX	400
	28	25	108	93	31.0	65	131.0	187	54	46.5	126	63.0	50	14	65	41	2274	KH3/2-28LX	400
S ⁴⁾	08	4	73	59	15.0	20	59.5	76	36.5	29.5	88	44.0	19	7	30	19	350	KH3/2-08SX	500
	10	6	73	58	15.0	30	59.5	76	36.5	29.0	90	45.0	19	7	30	22	300	KH3/2-10SX	500
	12	8	77	62	14.5	35	67.5	100	38.5	31.0	94	47.0	24	8	40	24	469	KH3/2-12SX	500
	14	10	81	65	14.5	35	67.5	100	40.5	32.5	100	50.0	24	8	40	27	500	KH3/2-14SX	500
	16	12	87	70	22.0	45	96.5	112	43.5	35.0	106	53.0	30	10	45	30	909	KH3/2-16SX	500
	20	16	90	69	25.0	50	110.0	166	45	34.5	112	56.0	36	11	50	36	949	KH3/2-20SX	400
	25	20	107	83	29.0	60	126.0	187	53.5	41.5	131	65.5	41	14	55	46	1714	KH3/2-25SX	400
	30	25	120	93	31.0	65	131.0	187	60	46.5	146	73.0	50	14	65	50	2462	KH3/2-30SX	400

1) Pressure shown = item deliverable

3) L = light series; *) S = heavy series

$\frac{PN \text{ (bar)}}{10} = PN \text{ (MPa)}$

Delivery without nut and ring. Information on ordering complete fittings or alternative sealing materials see page I7.

*Please add the **suffixes** below according to the material/surface required.

Order code suffixes			
Material	Suffix surface and material	Example	Standard sealing material (no additional suffix needed)
Steel, bronzed	DIN 50938-FE//A/T4	KH3/2-06LX	POM / NBR

KH 3-way compact BSPP ball valve steel

Female BSPP thread (ISO 1179-1) / Female BSPP thread (ISO 1179-1) / Female BSPP thread (ISO 1179-1)

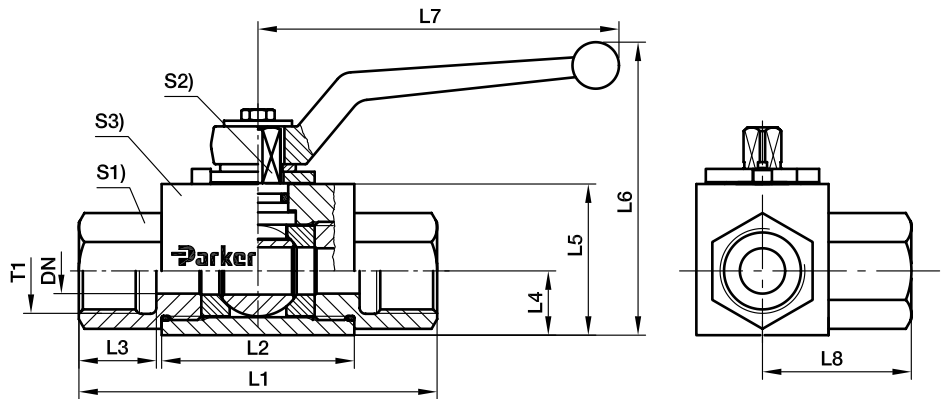

T1	DN	L1	L2	L3	L4	L5	L6	L7	L8	S1	S2	S3	Weight g/1 piece	Order code*	PN (bar) ¹⁾ bronzed
G 1/8	4	69	36	12	15.0	30	55	76	34.5	19	7	30	270	KH3/2-1/8X	500
G 1/4	6	69	36	12	15.0	30	55	76	34.5	19	7	30	342	KH3/2-1/4X	500
G 3/8	10	73	45	14	14.5	35	68	100	36.5	24	8	40	563	KH3/2-3/8X	500
G 1/2	12	82	51	15	22.0	45	92	112	41.0	30	10	45	932	KH3/2-1/2X	500
G 3/4	20	93	60	18	29.0	60	113	187	48.0	41	14	55	1724	KH3/2-3/4X	400
G 1	25	118	70	20	31.0	65	118	187	56.5	50	14	65	2643	KH3/2-1X	400

¹⁾ Pressure shown = item deliverable

$$\frac{PN \text{ (bar)}}{10} = PN \text{ (MPa)}$$

Delivery without nut and ring. Information on ordering complete fittings or alternative sealing materials see page 17.

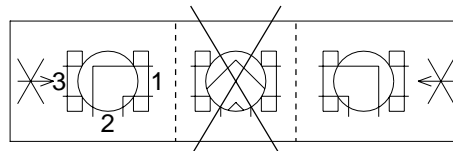

L-Version

*Please add the **suffixes** below according to the material/surface required.

Order code suffixes			
Material	Suffix surface and material	Example	Standard sealing material (no additional suffix needed)
Steel, bronzed	DIN 50938-FE//A/T4	KH3/2-1/8X	POM / NBR

ELA air-bleed valves

Hydraulic systems can effectively be bled with ELA air-bleed valves.

Easily installed – maintenance-free – almost unlimited service life – simple – safe – reliable – efficient. The system can be operated immediately. No control irregularities due to air contamination of the pressure medium. Cost saving, as non-productive de-aeration time is saved.

Air bleed between: – opening pressure 0.05 bar
– closing pressure ≥ 0.5 bar

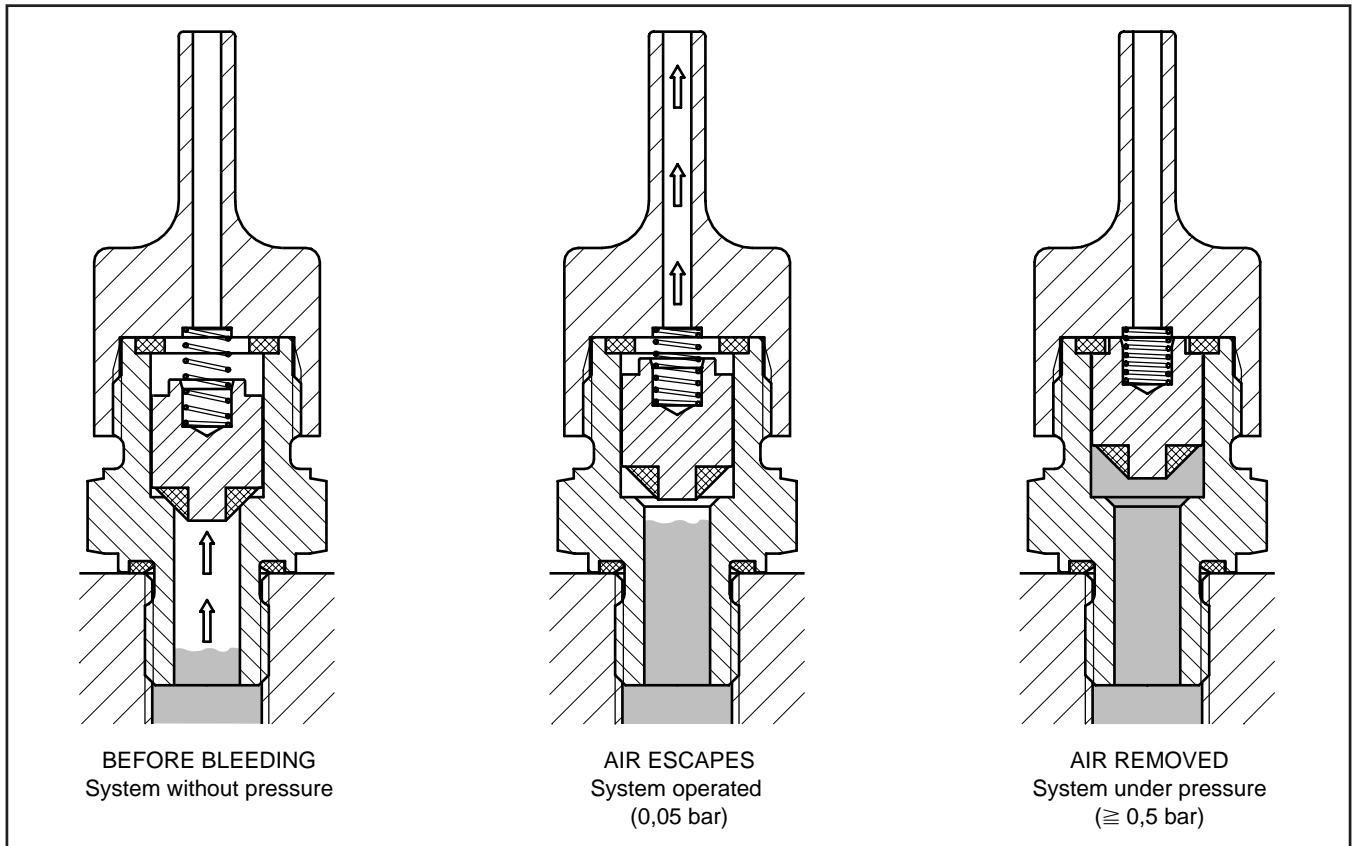

The principle of the air-bleed valve is based on the difference in behaviour of gases and liquids under pressure because of their dependence on viscosity. A piston, housed in the bore of the body with defined clearance, effects the opening and closing of the valve on start-up or shut-down of the system. On setting the system in operation, the accumulated air escapes until the liquid column of the pressure medium reaches the piston. The pressure of the liquid lifts the piston against the upper, high pressure seal, securely closing the air-vent (slight oil discharge may occur). When pressure is released the spring releases the piston reopening the air-vent, whereupon the procedure may be repeated. The special piston design prevents any intake of air in case of partial vacuum.

The air bleed valve should be connected vertical, at the highest point of the hydraulic system or in places where air accumulation may occur.

ELA air-bleed valves are available only for mineral oil based fluids, and within the temperature limits of -20°C to $+90^{\circ}\text{C}$.

ELA Air-bleed valves

Male BSPP thread with Eolastic seal

PN (bar)	Dry Technology Steel	Weight g/1 piece
400	ELA1/4EDA3C	109

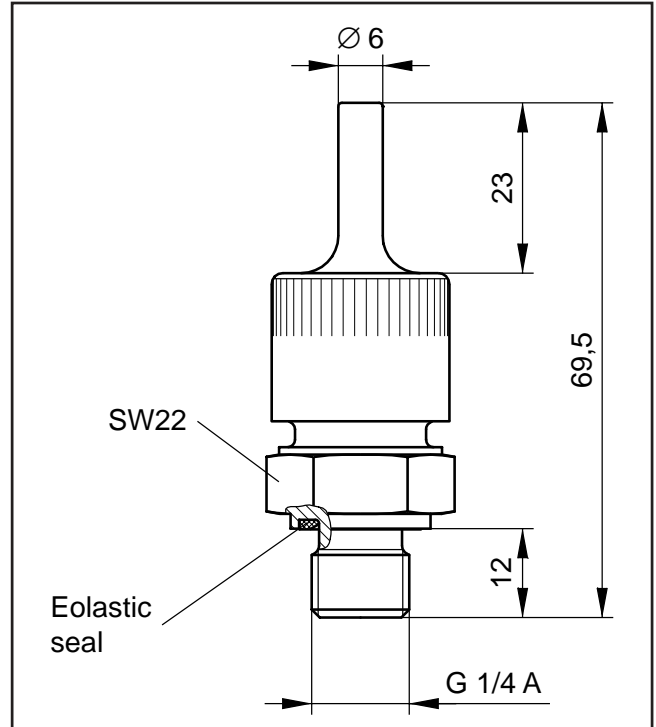

EO Swivel

PN (bar)	Dry Technology Steel	Weight g/1 piece
315	ELAE10LA3C	125

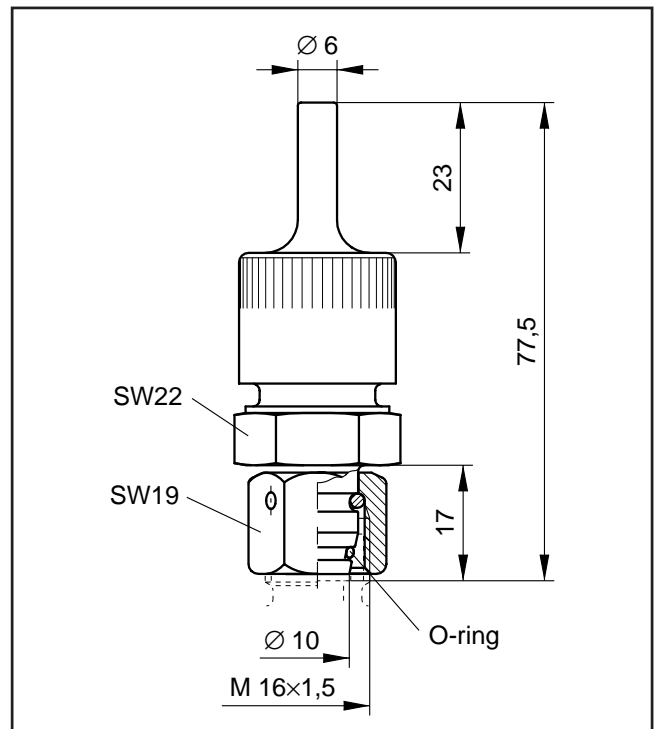



EO[®] Ermeto Original
Rotary fittings



Visual index EO rotary fittings

DG 101
p. P6

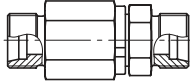

EO 24° cone end /
EO 24° cone end

DG 102-R
p. P7

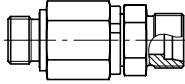

Male BSPP thread –
ED-seal (ISO 1179) / EO 24° cone end

DG 102-M
p. P8

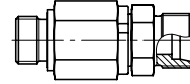

Male metric thread –
ED-seal (ISO 9974) / EO 24° cone end

DG 103
p. P9

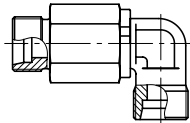

EO 24° cone end /
EO 24° cone end

DG 104-R
p. P10

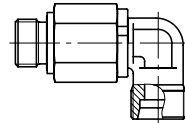

Male BSPP thread –
ED-seal (ISO 1179) / EO 24° cone end

DG 104-M
p. P11

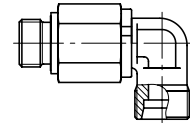

Male metric thread –
ED-seal (ISO 9974) / EO 24° cone end

DG 105
p. P12

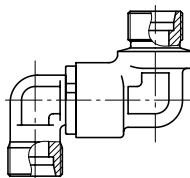

EO 24° cone end /
EO 24° cone end

DG 106-R
p. P13

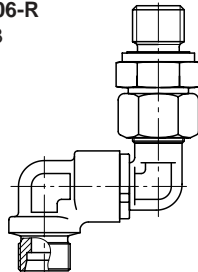

Male BSPP thread –
ED-seal (ISO 1179) / EO 24° cone end

DG 106-M
p. P14

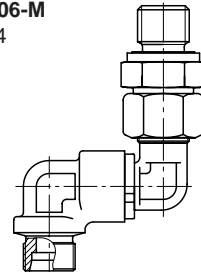

Male metric thread –
ED-seal (ISO 9974) / EO 24° cone end

DG 107
p. P15

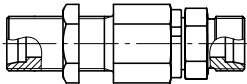

EO 24° cone end /
EO 24° cone end

DG 108
p. P16

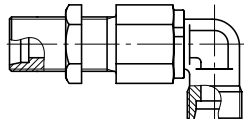

EO 24° cone end /
EO 24° cone end

DVGE-R
p. P17

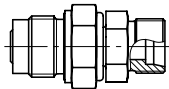

Male BSPP thread –
ED-seal / EO 24° cone end

DVGE-M
p. P18

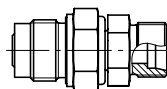

Male metric thread –
ED-seal / EO 24° cone end

DVWE-R
p. P19

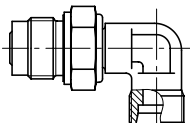

Male BSPP thread –
ED-seal / EO 24° cone end

DVWE-M
p. P20

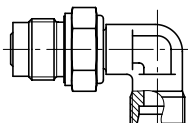

Male metric thread –
ED-seal / EO 24° cone end

DG Ball bearing rotary fittings

for working pressures up to 250 bar. Low starting torque. Favourable pressure/RPM ratio

Application:

Connecting a fixed point to a rotating, swinging or moving machine part via hoses.
To prevent torsion and to avoid small hose radius.

Flow media:

Hydraulic oils and lubricants on mineral oil base.
Also for hydraulic fluids HETG and HEES.
Not suitable for corrosive and HFC-fluids or gases.

Construction:

Compact, maintenance-free construction, service-proved. Combined ball and plain bearing with constant lubrication. Low starting torque. Wear-resistant annular piston sealings.

Materials:

Casing, body nut of steel, annular piston sealing: POM (e.g. Delrin)/FKM (e.g. Viton). Eolastic sealing: NBR (e.g. Perbunan), also available in FKM.

Surface:

Zinc-plated with yellow chromated (A3C).

Nominal temperatures:

-25° C up to +80° C.

Warehousing:

Ball bearing rotary fittings can be stocked for 6 months. Warehousing up to 1 year is possible with storage conditions acc. to DIN 7716.

Construction systems:

8 different versions with one rotational axis. Multiaxial rotary couplings on request. Tube connections according to DIN 2353, series S.
Maximum working pressure 250 bar (peak pressure)
Male stud sealing by Eolastic seals of NBR.
Male stud with metric parallel or BSPP thread.

Assembly instructions:

The life of a rotary fitting depends considerably on a stress-free line connection. Therefore the direct connection with tubes is to be avoided.
For connection of hoses the use of swivel nut fittings (DIN 3865) is recommended.
We recommend short, straight hose lines (free hose length approx. 5 x hose O.D.). Thus shocks, vibrations etc. are absorbed.

Number of revolutions and starting torques:

Chart 1

Tube O.D.	DN Nominal diameter (mm)	Permissible number of revolutions (rpm.) under a working pressure of					Initial torque at 250 bar/Nm
		25 bar	64 bar	100 bar	160 bar	250 bar	
6 8	5,0	1500	750	400	200	85	0.08
12 16	9,5	800	400	200	100	45	0.24
20 25	16,0	300	150	75	38	15	0.8
30 38	26,0	200	100	50	25	10	2.0

DG Ball bearing rotary fittings

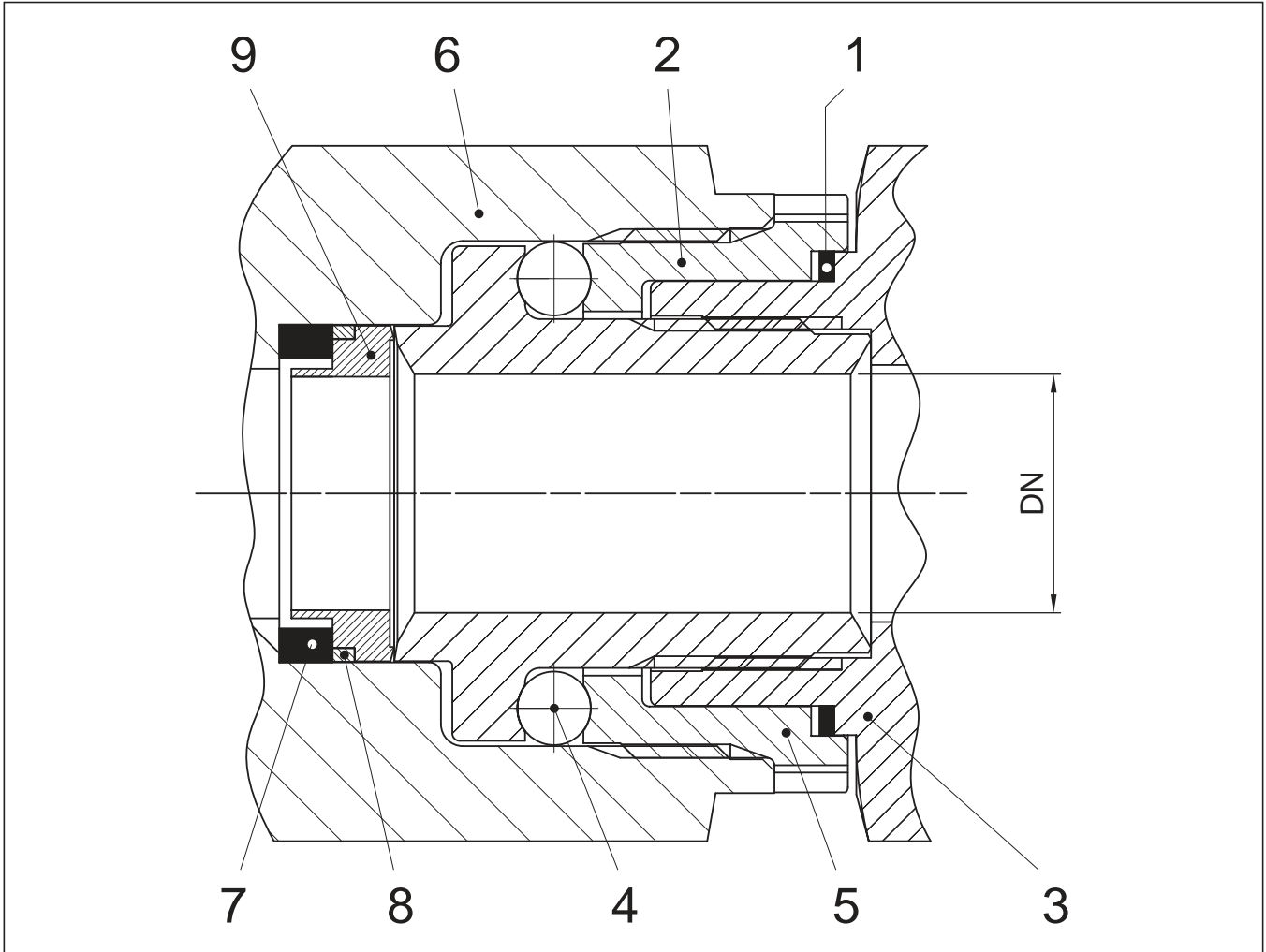

9	ring piston
8	intermediate ring
7	rubber spring
6	base
5	pivot
4	ball
3	top
2	raceway
1	dust seal
position	specification

Plain bearing rotary fittings

for slow rotating, swinging or moving machine parts up to 40 bar (series L) or up to 100 bar (series S).

Application:

Connecting a fixed point to a rotating, swinging or moving machine part via hoses.
To prevent torsion and to avoid small hose radius.

Flow media:

Hydraulic oils and lubricants on mineral oil base.
Also for hydraulic fluids HETG and HEES.
Not suitable for corrosive and HFC-fluids or gases.

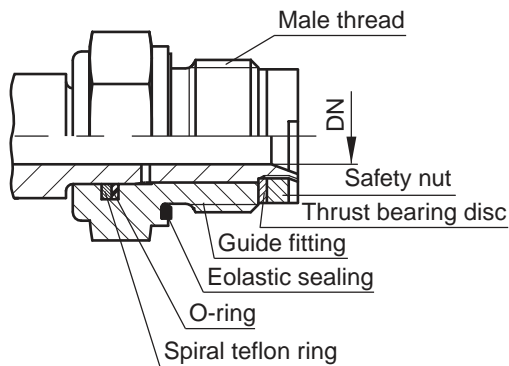

Nominal temperature:

For sealings of NBR:
-35° C up to +100° C.
For sealings of FKM:
-25° C up to +120° C.

Tube O.D.		DN Nominal diameter
06L	06S	4
08L	08S	5
10L	10S	6
12L	12S	8
15L	14S 16S	10
18L	22L 20S 25S	16
28L	30S	22
35L	43L 38S	25

Construction:

Compact, maintenance-free construction, service-proved.

Materials:

Casing, body nut and progressive ring of steel. Sealing of NBR (Perbunan), on request of FKM (Viton).
Plain bearing rotary fittings are not available in stainless steel or brass.

Surface:

Zinc-plated with yellow chromate (A3C).

Construction-system:

Series L, tube O. D. 6 to 35 mm, working pressure (PN): 40 bar
Series S, tube O. D. 6 to 38 mm, working pressure (PN): 100 bar
Tube connection according to DIN 2353, ISO 8434-1.
Male stud with metric thread and BSP thread.
Sealing of male stud by Eolastic-seals.

Number of revolutions:

Series	L									
Tube O.D.	6	8	10	12	15	18	22	28	35	
Permiss. no. rpm	28	28	21	17	13	10	10	7	7	
Series	S									
Tube O.D.	6	8	10	12	14	16	20	25	30	38
Permiss. no. rpm	11	11	9	7	5	5	4	4	3	3

Assembly instruction:

The life of a rotary fitting depends considerably on a stress-free line connection. Therefore the direct connection with tubes is to be avoided.
For connection of hoses use of swivel nut connections (DIN 3865) is recommended.
We recommend short, straight hose lines (free hose length approx. 5 hose O. D.). Thus shocks, vibrations etc. are absorbed.

DG 101 Straight ball bearing rotary union

EO 24° cone end / EO 24° cone end

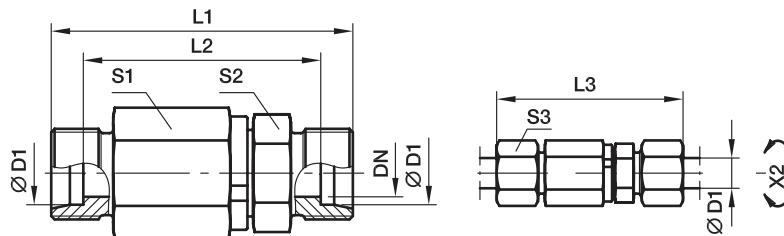

X2) Axis

Series	D1 	DN	L1	L2	L3	S1	S2	S3	Weight g/1 piece	Order code*	A3C ¹⁾
S ⁴⁾	06	5.0	61	47	76	22.0	17	17.0	113	DG101/06SOMD	Pressure rating see chart 1
	08	5.0	61	47	76	22.0	17	19.0	118	DG101/08SOMD	Pressure rating see chart 1
	12	9.5	72	57	89	30.0	24	24.0	258	DG101/12SOMD	Pressure rating see chart 1
	16	9.5	74	57	93	30.0	27	30.0	264	DG101/16SOMD	Pressure rating see chart 1
	20	16.0	92	71	114	41.0	36	36.0	578	DG101/20SOMD	Pressure rating see chart 1
	25	16.0	96	72	120	41.0	41	46.0	652	DG101/25SOMD	Pressure rating see chart 1
	30	26.0	109	82	135	60.0	46	50.0	1321	DG101/30SOMD	Pressure rating see chart 1
	38	26.0	114	82	143	60.0	55	60.0	1509	DG101/38SOMD	Pressure rating see chart 1

¹⁾ Pressure shown = item deliverable

⁴⁾ S = heavy series

$$\frac{PN \text{ (bar)}}{10} = PN \text{ (MPa)}$$

Delivery without nut and ring. Information on ordering complete fittings or alternative sealing materials see page 17.

*Please add the **suffixes** below according to the material/surface required.

Order code suffixes			
Material	Suffix surface and material	Example	Standard sealing material (no additional suffix needed)
Steel, zinc yellow plated	A3C	DG101/06SOMDA3C	VIT

DG 102-R Straight male stud ball bearing rotary union

Male BSPP thread – ED-seal (ISO 1179) / EO 24° cone end

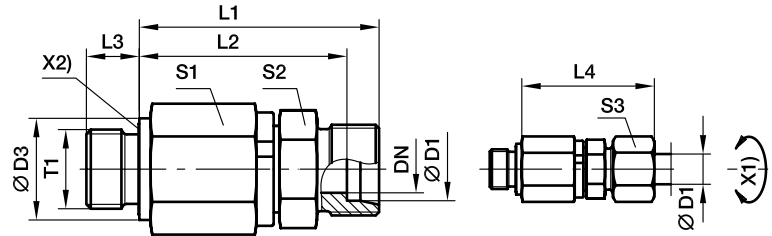

X1) Axis
X2) Eolastic-sealing

Series	D1	T1	DN	D3	L1	L2	L3	L4	S1	S2	S3	Weight g/1 piece	Order code*	A3C ¹⁾
S ⁴⁾	06	G 1/4 A	5.0	19	49	42.0	12	57.0	22	17	17	110	DG102/06SROMD	Pressure ratings see chart 1
	08	G 1/4 A	5.0	19	49	42.0	12	57.0	22	17	19	116	DG102/08SROMD	Pressure ratings see chart 1
	12	G 3/8 A	9.5	22	60	52.5	12	69.0	30	24	24	243	DG102/12SROMD	Pressure ratings see chart 1
	16	G 1/2 A	9.5	27	60	51.5	14	70.0	30	27	30	256	DG102/16SROMD	Pressure ratings see chart 1
	20	G 3/4 A	16.0	32	76	65.5	16	87.5	41	36	36	558	DG102/20SROMD	Pressure ratings see chart 1
	25	G 1 A	16.0	40	78	66.0	18	90.5	41	41	46	853	DG102/25SROMD	Pressure ratings see chart 1
	30	G 1 1/4 A	26.0	50	89	75.5	20	102.0	60	46	50	1312	DG102/30SROMD	Pressure ratings see chart 1
	38	G 1 1/2 A	26.0	55	92	76.0	22	107.0	60	55	60	1494	DG102/38SROMD	Pressure ratings see chart 1

¹⁾ Pressure shown = item deliverable

⁴⁾ S = heavy series

$$\frac{PN \text{ (bar)}}{10} = PN \text{ (MPa)}$$

Delivery without nut and ring. Information on ordering complete fittings or alternative sealing materials see page 17.

*Please add the **suffixes** below according to the material/surface required.

Order code suffixes			
Material	Suffix surface and material	Example	Standard sealing material (no additional suffix needed)
Steel, zinc yellow plated	A3C	DG102/06SROMDA3C	VIT/NBR

DG 102-M Straight male stud ball bearing rotary union

Male metric thread – ED-seal (ISO 9974) / EO 24° cone end

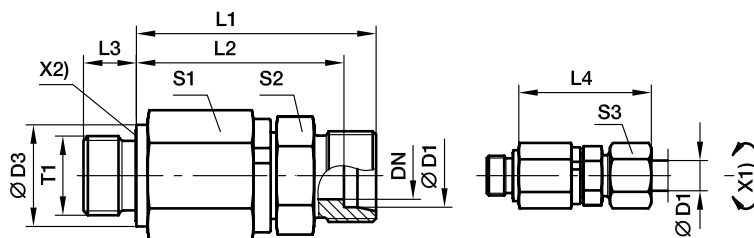

X1) Axis
X2) Eolastic-sealing

Series	D1	T1	DN	D3	L1	L2	L3	L4	S1	S2	S3	Weight g/1 piece	Order code*	A3C ¹⁾
S ⁴⁾	06	M 14 1.5	5.0	19	49	42.0	12	57.0	22	17	17	112	DG102/06SMOMD	Pressure ratings see chart 1
	08	M 14 1.5	5.0	19	49	42.0	12	57.0	22	17	19	113	DG102/08SMOMD	Pressure ratings see chart 1
	12	M 18 1.5	9.5	24	60	52.5	12	69.0	30	24	24	245	DG102/12SMOMD	Pressure ratings see chart 1
	16	M 22 1.5	9.5	27	60	51.5	14	70.0	30	27	30	259	DG102/16SMOMD	Pressure ratings see chart 1
	20	M 27 2	16.0	32	76	65.5	16	87.5	41	36	36	558	DG102/20SMOMD	Pressure ratings see chart 1
	25	M 33 2	16.0	40	78	66.0	18	90.5	41	41	46	637	DG102/25SMOMD	Pressure ratings see chart 1
	30	M 42 2	26.0	50	89	75.5	20	102.0	60	46	50	1316	DG102/30SMOMD	Pressure ratings see chart 1
	38	M 48 2	26.0	55	92	76.0	22	107.0	60	55	60	1491	DG102/38SMOMD	Pressure ratings see chart 1

¹⁾ Pressure shown = item deliverable

⁴⁾ S = heavy series

$$\frac{PN \text{ (bar)}}{10} = PN \text{ (MPa)}$$

Delivery without nut and ring. Information on ordering complete fittings or alternative sealing materials see page 17.

*Please add the **suffixes** below according to the material/surface required.

Order code suffixes			
Material	Suffix surface and material	Example	Standard sealing material (no additional suffix needed)
Steel, zinc yellow plated	A3C	DG102/06SMOMDA3C	VIT/NBR

DG 103 Elbow ball bearing rotary union

EO 24° cone end / EO 24° cone end

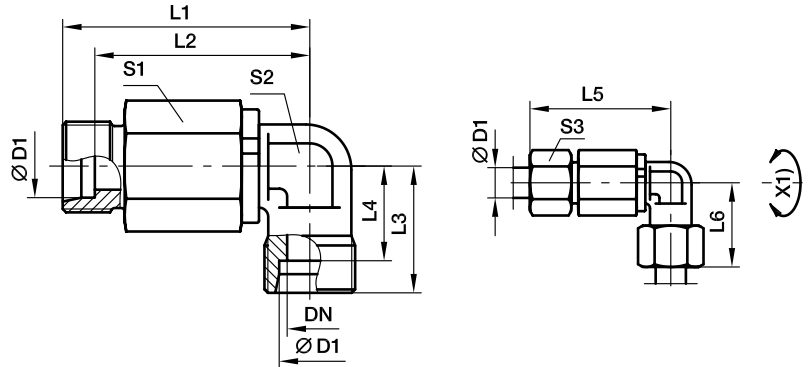

X2) Axis

Series	D1	DN	L1	L2	L3	L4	L5	L6	S1	S2	S3	Weight g/1 piece	Order code*	A3C ¹⁾
S ⁴⁾	06	5.0	51.5	59.0	23	16.0	44.5	16.0	22	17	17	134	DG103/06SOMD	Pressure ratings see chart 1
	08	5.0	51.5	59.0	24	17.0	44.5	17.0	22	17	19	141	DG103/08SOMD	Pressure ratings see chart 1
	12	9.5	63.0	72.0	29	21.5	55.5	21.5	30	22	24	296	DG103/12SOMD	Pressure ratings see chart 1
	16	9.5	63.0	73.0	33	24.5	54.5	24.5	30	22	30	298	DG103/16SOMD	Pressure ratings see chart 1
	20	16.0	83.0	94.5	37	26.5	72.5	26.5	41	36	36	772	DG103/20SOMD	Pressure ratings see chart 1
	25	16.0	83.0	95.5	42	30.0	71.0	30.0	41	36	46	803	DG103/25SOMD	Pressure ratings see chart 1
	30	26.0	102.5	116.0	49	35.5	89.0	35.5	60	50	50	1722	DG103/30SOMD	Pressure ratings see chart 1
38	26.0	102.5	117.0	57	41.0	86.5	41.0	60	50	60	1931	DG103/38SOMD	Pressure ratings see chart 1	

¹⁾ Pressure shown = item deliverable

⁴⁾ S = heavy series

$$\frac{\text{PN (bar)}}{10} = \text{PN (MPa)}$$

Delivery without nut and ring. Information on ordering complete fittings or alternative sealing materials see page 17.

*Please add the **suffixes** below according to the material/surface required.

Order code suffixes			
Material	Suffix surface and material	Example	Standard sealing material (no additional suffix needed)
Steel, zinc yellow plated	A3C	DG101/06SOMDA3C	VIT

DG 104-R Elbow male stud ball bearing rotary union

Male BSPP thread – ED-seal (ISO 1179) / EO 24° cone end

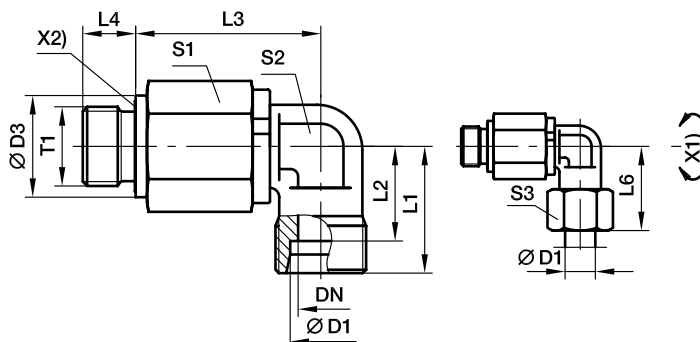

X1) Axis
X2) Elastic-sealing

Series	D1	T1	DN	D3	L1	L2	L3	L4	L6	S1	S2	S3	Weight g/1 piece	Order code*	A3C ¹⁾
S ⁴⁾	06	G 1/4 A	05	19	23	16.0	39.5	12	31	22	17	17	131	DG104/06SR0MD	Pressure ratings see chart 1
	08	G 1/4 A	05	19	24	17.0	39.5	12	32	22	17	19	135	DG104/08SR0MD	Pressure ratings see chart 1
	12	G 3/8 A	10	22	29	21.5	51.0	12	38	30	22	24	284	DG104/12SR0MD	Pressure ratings see chart 1
	16	G 1/2 A	10	27	33	24.5	49.0	14	43	30	22	30	284	DG104/16SR0MD	Pressure ratings see chart 1
	20	G 3/4 A	16	32	37	26.5	67.0	16	48	41	36	36	752	DG104/20SR0MD	Pressure ratings see chart 1
	25	G 1 A	16	40	42	30.0	65.0	18	54	41	36	46	789	DG104/25SR0MD	Pressure ratings see chart 1
	30	G 1 1/4 A	26	50	49	35.5	82.5	20	62	60	50	50	1713	DG104/30SR0MD	Pressure ratings see chart 1
	38	G 1 1/2 A	26	55	57	41.0	80.5	22	72	60	50	60	1915	DG104/38SR0MD	Pressure ratings see chart 1

¹⁾ Pressure shown = item deliverable

⁴⁾ S = heavy series

$\frac{PN \text{ (bar)}}{10} = PN \text{ (MPa)}$

Delivery without nut and ring. Information on ordering complete fittings or alternative sealing materials see page I7.

*Please add the **suffixes** below according to the material/surface required.

Order code suffixes			
Material	Suffix surface and material	Example	Standard sealing material (no additional suffix needed)
Steel, zinc yellow plated	A3C	DG104/06SR0MDA3C	VIT/NBR

DG 104-M Elbow male stud ball bearing rotary union

Male metric thread – ED-seal (ISO 9974) / EO 24° cone end

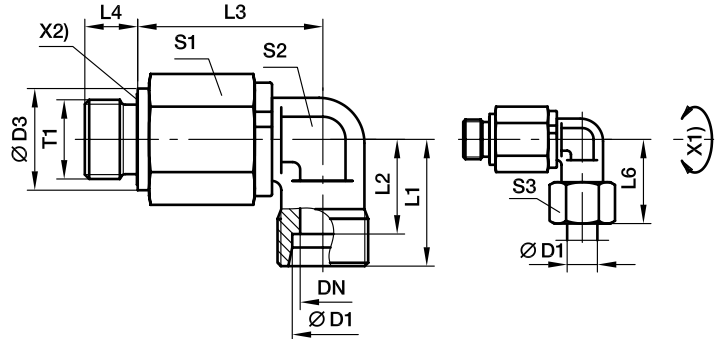

X1) Axis

X2) Elastic-sealing

Series	D1	T1	DN	D3	L1	L2	L3	L4	L6	S1	S2	S3	Weight g/1 piece	Order code*	A3C ¹⁾
S ⁴⁾	06	M 14 1.5	05	19	23	16.0	39.5	12	31	22	17	17	132	DG104/06SMOMD	Pressure ratings see chart 1
	08	M 14 1.5	05	19	24	17.0	39.5	12	32	22	17	19	136	DG104/08SMOMD	Pressure ratings see chart 1
	12	M 18 1.5	10	22	29	21.5	51.0	12	38	30	22	24	286	DG104/12SMOMD	Pressure ratings see chart 1
	16	M 22 1.5	10	27	33	24.5	49.0	14	43	30	22	30	287	DG104/16SMOMD	Pressure ratings see chart 1
	20	M 27 2	16	32	37	26.5	67.0	16	48	41	36	36	752	DG104/20SMOMD	Pressure ratings see chart 1
	25	M 33 2	16	40	42	30.0	65.0	18	54	41	36	46	788	DG104/25SMOMD	Pressure ratings see chart 1
	30	M 42 2	26	50	49	35.5	82.5	20	62	60	50	50	1717	DG104/30SMOMD	Pressure ratings see chart 1
	38	M 48 2	26	55	57	41.0	80.5	22	72	60	50	60	1913	DG104/38SMOMD	Pressure ratings see chart 1

¹⁾ Pressure shown = item deliverable

⁴⁾ S = heavy series

$\frac{PN \text{ (bar)}}{10} = PN \text{ (MPa)}$

Delivery without nut and ring. Information on ordering complete fittings or alternative sealing materials see page I7.

*Please add the **suffixes** below according to the material/surface required.

Order code suffixes			
Material	Suffix surface and material	Example	Standard sealing material (no additional suffix needed)
Steel, zinc yellow plated	A3C	DG104/06SMOMDA3C	VIT/NBR

DG 105 Double elbow ball bearing rotary union

EO 24° cone end / EO 24° cone end

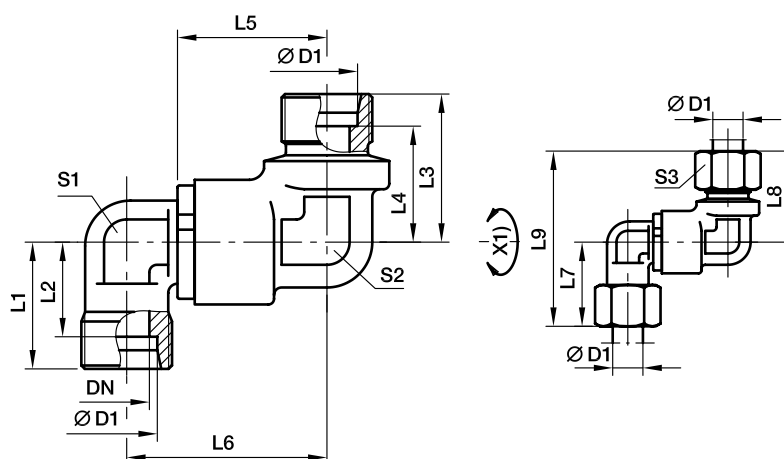

X1) Axis

Series	D1	DN	L1	L2	L3	L4	L5	L6	L7	L8	L9	S1	S2	S3	Weight g/1 piece	Order code*	A3C ¹⁾
S ⁴⁾	12	9.5	39.5	26.5	43	21.5	38	81	53.0	24	22	24	29	50.5	384	DG105/12SOMD	Pressure ratings see chart 1
	16	9.5	39.5	25.5	44	24.5	43	87	53.0	30	22	24	33	52.5	377	DG105/16SOMD	Pressure ratings see chart 1
	20	16.0	56.5	39.5	61	26.5	48	109	76.0	36	36	32	37	71.5	1015	DG105/20SOMD	Pressure ratings see chart 1
	25	16.0	56.5	38.0	62	30.0	54	116	76.0	46	36	32	42	74.0	1034	DG105/25SOMD	Pressure ratings see chart 1
	30	26.0	65.0	44.5	71	35.5	62	133	92.5	50	50	50	49	84.5	2344	DG105/30SOMD	Pressure ratings see chart 1
	38	26.0	65.0	42.0	73	41.0	72	145	92.5	60	50	50	57	89.0	2485	DG105/38SOMD	Pressure ratings see chart 1

¹⁾ Pressure shown = item deliverable

⁴⁾ S = heavy series

$$\frac{PN \text{ (bar)}}{10} = PN \text{ (MPa)}$$

Delivery without nut and ring. Information on ordering complete fittings or alternative sealing materials see page 17.

*Please add the **suffixes** below according to the material/surface required.

Order code suffixes			
Material	Suffix surface and material	Example	Standard sealing material (no additional suffix needed)
Steel, zinc yellow plated	A3C	DG105/12SOMDA3C	VIT

DG 106-R Double elbow male stud ball bearing rotary union

Male BSPP thread – ED-seal (ISO 1179) / EO 24° cone end
(Adjustable at male thread axis, consisting of DG105 + EGE)

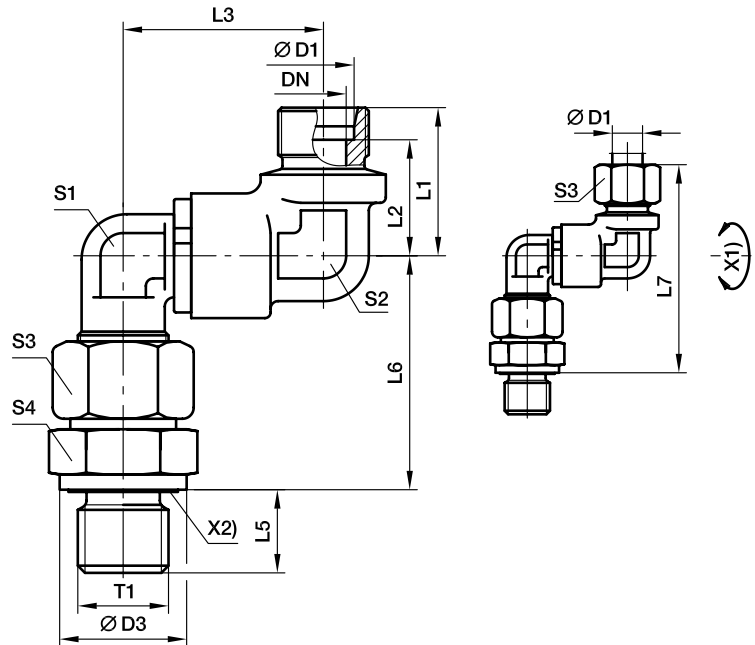

X1) Axis
X2) Eolastic-sealing

Series	D1	T1	DN	D3	L1	L2	L3	L4	L6	L7	S1	S2	S3	S4	Weight g/1 piece	Order code*	A3C ¹⁾
S ⁴⁾	12	G 3/8 A	5.0	24	34	26.5	53.0	12	55.5	99	24	22	24	22	484	DG106/12SR0MD	Pressure ratings see chart 1
	16	G 1/2 A	9.5	27	34	25.5	53.0	14	61.5	105	24	24	30	27	547	DG106/16SR0MD	Pressure ratings see chart 1
	20	G 3/4 A	16.0	32	50	39.5	76.0	16	69.5	131	36	32	36	32	1288	DG106/20SR0MD	Pressure ratings see chart 1
	25	G 1 A	16.0	40	50	38.0	76.0	18	78.0	140	36	32	46	41	1528	DG106/25SR0MD	Pressure ratings see chart 1
	30	G 1 1/4 A	26.0	50	58	44.5	92.5	20	86.5	158	50	50	50	50	3004	DG106/30SR0MD	Pressure ratings see chart 1
	38	G 1 1/2 A	26.0	55	58	42.0	92.5	22	101.0	174	50	50	60	55	3419	DG106/38SR0MD	Pressure ratings see chart 1

¹⁾ Pressure shown = item deliverable

⁴⁾ S = heavy series

$\frac{PN \text{ (bar)}}{10} = PN \text{ (MPa)}$

Delivery without nut and ring. Information on ordering complete fittings or alternative sealing materials see page 17.

*Please add the **suffixes** below according to the material/surface required.

Order code suffixes			
Material	Suffix surface and material	Example	Standard sealing material (no additional suffix needed)
Steel, zinc yellow plated	A3C	DG106/06SR0MDA3C	VIT/NBR

DG 106-M Double elbow male stud ball bearing rotary union

Male metric thread – ED-seal (ISO 9974) / EO 24° cone end
(Adjustable at male thread axis, consisting of DG105 + EGE)

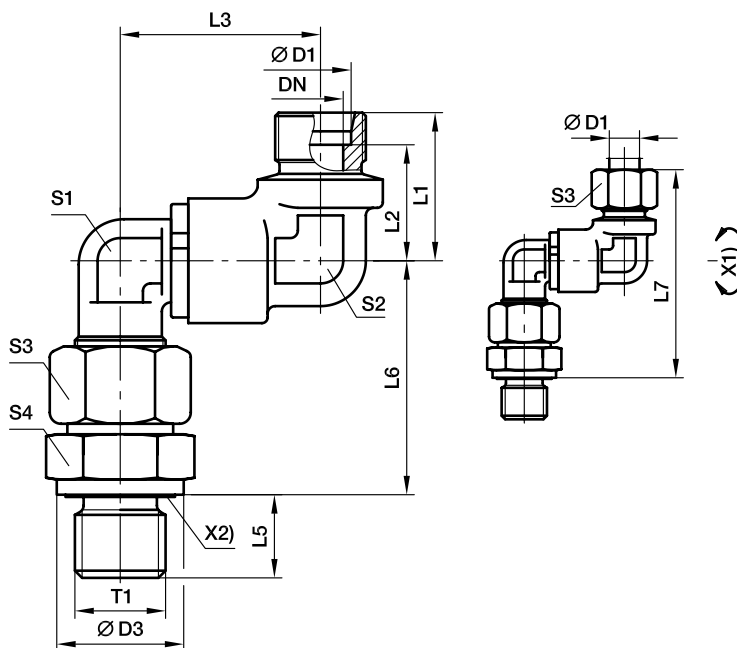

X1) Axis
X2) Eolastic-sealing

Series	D1	T1	DN	D3	L1	L2	L3	L4	L6	L7	S1	S2	S3	S4	Weight g/1 piece	Order code*	A3C ¹⁾
S ⁴⁾	12	M 18 1.5	5.0	24	34	26.5	53.0	12	55.5	99	24	22	24	24	495	DG106/12SMOMD	Pressure ratings see chart 1
	16	M 22 1.5	9.5	27	34	25.5	53.0	14	61.5	105	24	24	30	27	551	DG106/16SMOMD	Pressure ratings see chart 1
	20	M 27 2	16.0	32	50	39.5	76.0	16	69.5	131	36	32	36	32	1289	DG106/20SMOMD	Pressure ratings see chart 1
	25	M 33 2	16.0	40	50	38.0	76.0	18	78.0	140	36	32	46	41	1532	DG106/25SMOMD	Pressure ratings see chart 1
	30	M 42 2	26.0	50	58	44.5	92.5	20	86.5	158	50	50	50	50	3007	DG106/30SMOMD	Pressure ratings see chart 1
	38	M 48 2	26.0	55	58	42.0	92.5	22	101.0	174	50	50	60	55	3441	DG106/38SMOMD	Pressure ratings see chart 1

¹⁾ Pressure shown = item deliverable

⁴⁾ S = heavy series

$$\frac{PN \text{ (bar)}}{10} = PN \text{ (MPa)}$$

Delivery without nut and ring. Information on ordering complete fittings or alternative sealing materials see page 17.

*Please add the **suffixes** below according to the material/surface required.

Order code suffixes			
Material	Suffix surface and material	Example	Standard sealing material (no additional suffix needed)
Steel, zinc yellow plated	A3C	DG106/06SMOMDA3C	VIT/NBR

DG 107 Straight bulkhead ball bearing rotary union

EO 24° cone end / EO 24° cone end

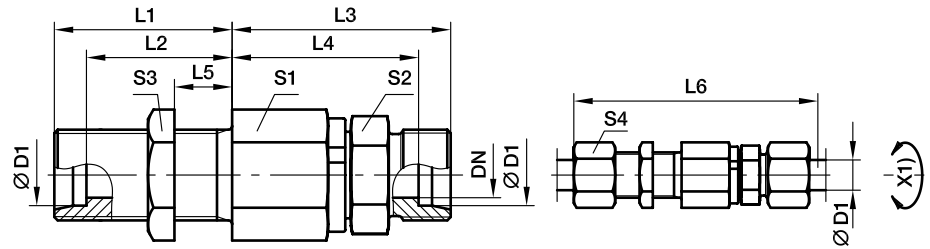

X1) Axis

Series	D1	DN	T1	L1	L2	L3	L4	L5	L6	S1	S2	S3	S4	Weight g/1 piece	Order code*	A3C ¹⁾	
S ⁴⁾	06	5.0	M 14	1.5	23	16.0	49	42.0	5	87	22	17	19	17	134	DG107/06SOMD	Pressure ratings see chart 1
	08	5.0	M 16	1.5	23	16.0	49	42.0	5	87	22	17	22	19	143	DG107/08SOMD	Pressure ratings see chart 1
	12	9.5	M 20	1.5	23	15.5	60	52.5	5	100	30	24	27	24	291	DG107/12SOMD	Pressure ratings see chart 1
	16	9.5	M 24	1.5	26	17.5	60	51.5	5	105	30	27	32	30	328	DG107/16SOMD	Pressure ratings see chart 1
	20	16.0	M 30	2	39	28.5	76	65.5	15	137	41	36	41	36	710	DG107/20SOMD	Pressure ratings see chart 1
	25	16.0	M 36	2	42	30.0	78	66.0	15	144	41	41	46	46	847	DG107/25SOMD	Pressure ratings see chart 1
	30	26.0	M 42	2	44	30.5	89	75.5	15	159	60	46	50	50	1533	DG107/30SOMD	Pressure ratings see chart 1
	38	26.0	M 52	2	47	31.0	92	76.0	15	168	60	55	65	60	1930	DG107/38SOMD	Pressure ratings see chart 1

¹⁾ Pressure shown = item deliverable

⁴⁾ S = heavy series

$$\frac{PN \text{ (bar)}}{10} = PN \text{ (MPa)}$$

Delivery without nut and ring. Information on ordering complete fittings or alternative sealing materials see page 17.

*Please add the **suffixes** below according to the material/surface required.

Order code suffixes			
Material	Suffix surface and material	Example	Standard sealing material (no additional suffix needed)
Steel, zinc yellow plated	A3C	DG107/06SOMDA3C	VIT

DG 108 Elbow bulkhead ball bearing rotary union

EO 24° cone end / EO 24° cone end

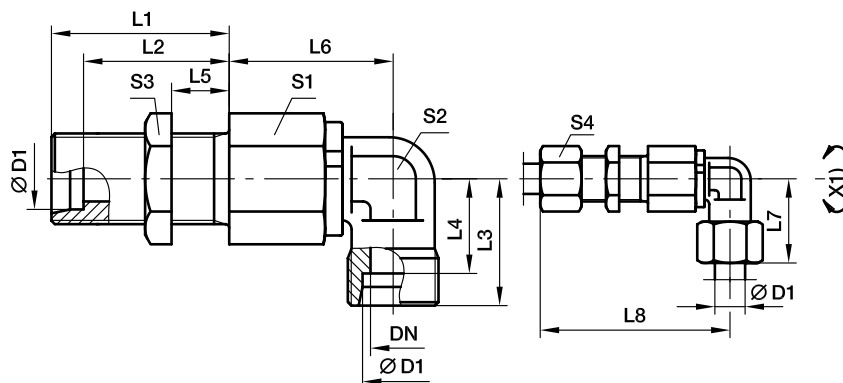

X1) Axis

Series	D1	DN	T1	L1	L2	L3	L4	L5	L6	L7	L8	S1	S2	S3	S4	Weight g/1 piece	Order code*	A3C ¹⁾	
S ⁴⁾	06	5.0	M 14	1.5	23	16.0	23	16.0	5	39.5	31	70.0	22	17	19	17	154	DG108/06SOMD	Pressure ratings see chart 1
	08	5.0	M 16	1.5	23	16.0	23	17.0	5	39.5	32	70.0	22	17	22	19	166	DG108/08SOMD	Pressure ratings see chart 1
	12	9.5	M 20	1.5	23	15.5	29	21.5	5	51.0	38	83.0	30	22	27	24	333	DG108/12SOMD	Pressure ratings see chart 1
	16	9.5	M 24	1.5	26	17.5	33	24.5	5	49.0	43	85.0	30	22	32	30	354	DG108/16SOMD	Pressure ratings see chart 1
	20	16.0	M 30	2	39	28.5	37	26.5	15	67.0	48	117.5	41	36	41	36	904	DG108/20SOMD	Pressure ratings see chart 1
	25	16.0	M 36	2	42	30.0	42	30.0	15	65.0	54	119.5	41	36	46	46	999	DG108/25SOMD	Pressure ratings see chart 1
	30	26.0	M 42	2	44	30.5	49	35.5	15	82.5	62	140.0	60	50	50	50	1935	DG108/30SOMD	Pressure ratings see chart 1
	38	26.0	M 52	2	47	31.0	57	41.0	15	80.5	72	142.0	60	50	65	60	2351	DG108/38SOMD	Pressure ratings see chart 1

¹⁾ Pressure shown = item deliverable

⁴⁾ S = heavy series

$$\frac{PN \text{ (bar)}}{10} = PN \text{ (MPa)}$$

Delivery without nut and ring. Information on ordering complete fittings or alternative sealing materials see page 17.

*Please add the **suffixes** below according to the material/surface required.

Order code suffixes			
Material	Suffix surface and material	Example	Standard sealing material (no additional suffix needed)
Steel, zinc yellow plated	A3C	DG108/06SOMDA3C	VIT

DVGE-R Straight male stud plain bearing rotary union

Male BSPP thread – ED-seal / EO 24° cone end

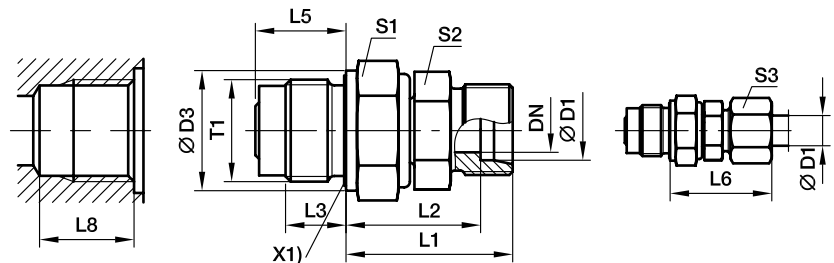

L8 larger than DIN 3852
chart page P21

X1) Eolastic-sealing

Series	D1	T1	DN	D3	L1	L2	L3	L5	L6	S1	S2	S3	Weight g/1 piece	Order code*	PN (bar) ¹⁾	
															A3C	VIT
L ³⁾	06	G 1/4 A	4.0	19	28.0	21.0	12	18.0	40	19	12	14	43	DVGE06LROMD	40	40
	08	G 1/4 A	5.0	19	28.0	21.0	12	18.0	40	19	14	17	44	DVGE08LROMD	40	40
	10	G 3/8 A	6.0	22	32.0	25.0	12	18.0	40	24	17	19	74	DVGE10LROMD	40	40
	12	G 1/2 A	8.0	27	34.0	27.0	14	21.0	42	27	19	22	116	DVGE12LROMD	40	40
	15	G 3/4 A	10.0	32	39.0	32.0	16	24.0	47	32	24	27	214	DVGE15LROMD	40	40
	18	G 1 A	16.0	40	42.5	35.0	18	27.5	51	41	27	32	337	DVGE18LROMD	40	40
	22	G 1 A	16.0	40	46.5	39.0	18	27.5	55	41	32	36	376	DVGE22LROMD	40	40
	28	G 1 1/4 A	22.0	50	48.0	40.5	20	31.0	57	50	41	41	586	DVGE28LROMD	40	40
	35	G 1 1/2 A	25.0	55	55.0	44.5	22	35.0	66	55	46	50	868	DVGE35LROMD	40	40
S ⁴⁾	06	G 1/4 A	4.0	19	30.0	23.0	12	18.0	38	19	14	17	50	DVGE06SROMD	100	100
	08	G 1/4 A	5.0	19	31.0	24.0	12	18.0	39	19	17	19	55	DVGE08SROMD	100	100
	10	G 3/8 A	6.0	22	34.0	26.5	12	18.0	43	24	19	22	85	DVGE10SROMD	100	100
	12	G 1/2 A	8.0	27	36.0	28.5	14	21.0	45	27	22	24	134	DVGE12SROMD	100	100
	14	G 3/4 A	10.0	32	41.0	33.0	16	24.0	51	32	24	27	220	DVGE14SROMD	100	100
	16	G 3/4 A	10.0	32	42.0	33.5	16	24.0	52	32	27	30	230	DVGE16SROMD	100	100
	20	G 1 A	16.0	40	48.5	38.0	18	27.5	60	41	32	36	385	DVGE20SROMD	100	100
	25	G 1 A	16.0	40	52.5	40.5	18	27.5	65	41	41	46	483	DVGE25SROMD	100	100
	30	G 1 1/4 A	22.0	50	55.0	41.5	20	31.0	68	50	46	50	691	DVGE30SROMD	100	100
	38	G 1 1/2 A	25.0	55	63.0	47.0	22	35.0	78	55	55	60	1080	DVGE38SROMD	100	100

¹⁾ Pressure shown = item deliverable

³⁾ L = light series; ⁴⁾ S = heavy series

$\frac{\text{PN (bar)}}{10} = \text{PN (MPa)}$

Delivery without nut and ring. Information on ordering complete fittings or alternative sealing materials see page I7.

*Please add the **suffixes**
below according to the material/
surface required.

Order code suffixes			
Material	Suffix surface and material	Example	Standard sealing material (no additional suffix needed)
Steel, zinc yellow plated	A3C	DVGE06LROMDA3C	NBR
FKM (Viton)	VITA3C	DVGE06LROMDVITA3C	

DVGE-M Straight male stud plain bearing rotary union

Male metric thread – ED-seal / EO 24° cone end

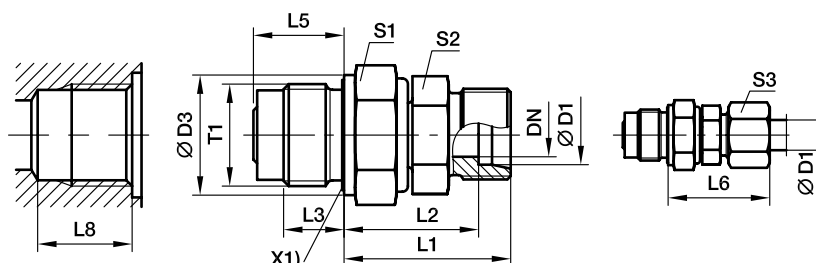

L8 larger than DIN 3852
chart page P21

X1) Elastic-sealing

Series	D1	T1	DN	D3	L1	L2	L3	L5	L6	S1	S2	S3	Weight g/1 piece	Order code*	PN (bar) ¹⁾	
															A3C	VIT
L ³⁾	06	M 14 1.5	4.0	19	27.0	20.0	12	18.0	27	19	12	14	44	DVGE06LMOMD	40	40
	08	M 14 1.5	5.0	19	28.0	21.0	12	18.0	29	19	12	17	45	DVGE08LMOMD	40	40
	10	M 18 1.5	6.0	24	33.0	26.0	12	18.0	30	24	14	19	87	DVGE10LMOMD	40	40
	12	M 22 1.5	8.0	27	34.0	27.0	14	21.0	32	27	17	22	120	DVGE12LMOMD	40	40
	15	M 27 2	10.0	32	40.0	33.0	16	24.0	36	32	19	27	215	DVGE15LMOMD	40	40
	18	M 33 2	16.0	40	45.0	37.5	18	27.5	40	41	27	32	349	DVGE18LMOMD	40	40
	22	M 33 2	16.0	40	47.0	39.5	18	27.5	44	41	27	36	383	DVGE22LMOMD	40	40
	28	M 42 2	22.0	50	51.5	44.0	20	31.0	47	50	36	41	590	DVGE28LMOMD	40	40
	35	M 48 2	25.0	55	64.5	54.0	22	35.0	56	55	41	50	876	DVGE35LMOMD	40	40
S ⁴⁾	06	M 14 1.5	4.0	19	28.0	21.0	12	18.0	31	19	12	17	51	DVGE06SMOMD	100	100
	08	M 14 1.5	5.0	19	29.0	22.0	12	18.0	32	19	14	19	56	DVGE08SMOMD	100	100
	10	M 18 1.5	6.0	24	34.5	27.0	12	18.0	34	24	17	22	98	DVGE10SMOMD	100	100
	12	M 22 1.5	8.0	27	35.5	28.0	14	21.0	38	27	17	24	139	DVGE12SMOMD	100	100
	16	M 27 2	10.0	32	42.5	34.0	16	24.0	43	32	24	30	239	DVGE16SMOMD	100	100
	20	M 33 2	16.0	40	50.0	39.5	18	27.5	48	41	27	36	385	DVGE20SMOMD	100	100
	25	M 33 2	16.0	40	54.5	42.5	18	27.5	54	41	36	46	494	DVGE25SMOMD	100	100
	30	M 42 2	22.0	50	61.5	48.0	20	31.0	62	50	41	50	695	DVGE30SMOMD	100	100
	38	M 48 2	25.0	55	71.0	55.0	22	35.0	72	55	50	60	1088	DVGE38SMOMD	100	100

¹⁾ Pressure shown = item deliverable

³⁾ L = light series; ⁴⁾ S = heavy series

$$\frac{\text{PN (bar)}}{10} = \text{PN (MPa)}$$

Delivery without nut and ring. Information on ordering complete fittings or alternative sealing materials see page I7.

*Please add the **suffixes** below according to the material/surface required.

Order code suffixes			
Material	Suffix surface and material	Example	Standard sealing material (no additional suffix needed)
Steel, zinc yellow plated	A3C	DVGE06LMOMDA3C	NBR
FKM (Viton)	VITA3C	DVGE06LMOMDVITA3C	

DVWE-R Elbow male stud plain bearing rotary union

Male BSPP thread – ED-seal / EO 24° cone end

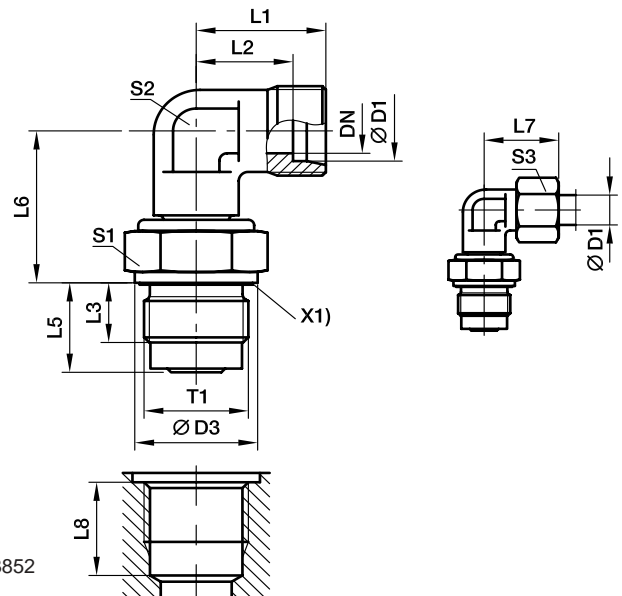

X1) Eolastic-sealing

L8 larger than DIN 3852
chart page P21

Series	D1	T1	DN	D3	L1	L2	L3	L5	L6	L7	S1	S2	S3	Weight g/1 piece	Order code*	PN (bar) ¹⁾	
																A3C	VIT
L ³⁾	06	G 1/4 A	4	19	19	12.0	12	18.0	20.0	27	19	12	14	50	DVWE06LROMD	40	40
	08	G 1/4 A	5	19	21	14.0	12	18.0	21.0	29	19	12	17	50	DVWE08LROMD	40	40
	10	G 3/8 A	6	22	22	15.0	12	18.0	26.0	30	24	14	19	83	DVWE10LROMD	40	40
	12	G 1/2 A	8	27	24	17.0	14	21.0	27.0	32	27	17	22	129	DVWE12LROMD	40	40
	15	G 3/4 A	10	32	28	21.0	16	24.0	33.0	36	32	19	27	232	DVWE15LROMD	40	40
	18	G 1 A	16	40	31	23.5	18	27.5	37.5	40	41	27	32	393	DVWE18LROMD	40	40
	22	G 1 A	16	40	35	27.5	18	27.5	39.5	44	41	27	36	406	DVWE22LROMD	40	40
	28	G 1 1/4 A	22	50	38	30.5	20	31.0	44.0	47	50	36	41	664	DVWE28LROMD	40	40
	35	G 1 1/2 A	25	55	45	34.5	22	35.0	54.0	56	55	41	50	1005	DVWE35LROMD	40	40
S ⁴⁾	06	G 1/4 A	4	19	23	16.0	12	18.0	21.0	31	19	12	17	58	DVWE06SROMD	100	100
	08	G 1/4 A	5	19	24	17.0	12	18.0	22.0	32	19	14	19	65	DVWE08SROMD	100	100
	10	G 3/8 A	6	22	25	17.5	12	18.0	27.0	34	24	17	22	103	DVWE10SROMD	100	100
	12	G 1/2 A	8	27	29	21.5	14	21.0	28.0	38	27	17	24	152	DVWE12SROMD	100	100
	14	G 3/4 A	10	32	30	22.0	16	24.0	33.0	40	32	19	27	236	DVWE14SROMD	100	100
	16	G 3/4 A	10	32	33	24.5	16	24.0	34.0	43	32	24	30	276	DVWE16SROMD	100	100
	20	G 1 A	16	40	37	26.5	18	27.5	39.5	48	41	27	36	415	DVWE20SROMD	100	100
	25	G 1 A	16	40	42	30.0	18	27.5	42.5	54	41	36	46	569	DVWE25SROMD	100	100
	30	G 1 1/4 A	22	50	49	35.5	20	31.0	48.0	62	50	41	50	886	DVWE30SROMD	100	100
	38	G 1 1/2 A	25	55	57	41.0	22	35.0	55.0	72	55	50	60	1375	DVWE38SROMD	100	100

¹⁾ Pressure shown = item deliverable

³⁾ L = light series; ⁴⁾ S = heavy series

$$\frac{\text{PN (bar)}}{10} = \text{PN (MPa)}$$

Delivery without nut and ring. Information on ordering complete fittings or alternative sealing materials see page I7.

*Please add the **suffixes** below according to the material/surface required.

Order code suffixes			
Material	Suffix surface and material	Example	Standard sealing material (no additional suffix needed)
Steel, zinc yellow plated	A3C	DVWE06LROMDA3C	NBR
FKM (Viton)	VIT	DVWE06LROMDVITA3C	

DVWE-M Elbow male stud plain bearing rotary union

Male metric thread – ED-seal / EO 24° cone end

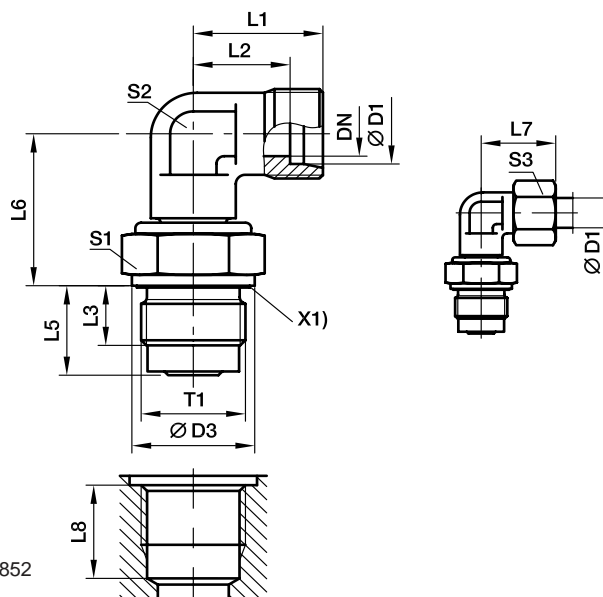

L8 larger than DIN 3852
chart page P21

X1) Eolastic-sealing

Series	D1	T1	DN	D3	L1	L2	L3	L5	L6	L7	S1	S2	S3	Weight g/1 piece	Order code*	PN (bar) ¹⁾	
																A3C	VIT
L ³⁾	06	M 14 1.5	4.0	19	19	12.0	12	18.0	20.0	27	19	12	14	51	DVWE06LMOMD	40	40
	08	M 14 1.5	5.0	19	21	14.0	12	18.0	21.0	29	19	12	17	51	DVWE08LMOMD	40	40
	10	M 18 1.5	6.0	24	22	15.0	12	18.0	26.0	30	24	14	19	92	DVWE10LMOMD	40	40
	12	M 22 1.5	8.0	27	24	17.0	14	21.0	27.0	32	27	17	22	160	DVWE12LMOMD	40	40
	15	M 27 2	10.0	32	28	21.0	16	24.0	33.0	36	32	19	27	236	DVWE15LMOMD	40	40
	18	M 33 2	16.0	40	31	23.5	18	27.5	37.5	40	41	27	32	405	DVWE18LMOMD	40	40
	22	M 33 2	16.0	40	35	27.5	18	27.5	39.5	44	41	27	36	409	DVWE22LMOMD	40	40
	28	M 42 2	22.0	50	38	30.5	20	31.0	44.0	47	50	36	41	660	DVWE28LMOMD	40	40
	35	M 48 2	25.0	55	45	34.5	22	35.0	54.0	56	55	41	50	1012	DVWE35LMOMD	40	40
	S ⁴⁾	06	M 14 1.5	4.0	19	23	16.0	12	18.0	21.0	31	19	12	17	59	DVWE06SMOMD	100
08		M 14 1.5	5.0	19	24	17.0	12	18.0	22.0	32	19	14	19	66	DVWE08SMOMD	100	100
10		M 18 1.5	6.0	24	25	17.5	12	18.0	27.0	34	24	17	22	113	DVWE10SMOMD	100	100
12		M 22 1.5	8.0	27	29	21.5	14	21.0	28.0	38	27	17	24	153	DVWE12SMOMD	100	100
16		M 27 2	10.0	32	33	24.5	16	24.0	34.0	43	32	24	30	284	DVWE16SMOMD	100	100
20		M 33 2	16.0	40	37	26.5	18	27.5	39.5	48	41	27	36	427	DVWE20SMOMD	100	100
25		M 33 2	16.0	40	42	30.0	18	27.5	42.5	54	41	36	46	581	DVWE25SMOMD	100	100
30		M 42 2	22.0	50	49	35.5	20	31.0	48.0	62	50	41	50	898	DVWE30SMOMD	100	100
38		M 48 2	25.0	55	57	41.0	22	35.0	55.0	72	55	50	60	1373	DVWE38SMOMD	100	100

¹⁾ Pressure shown = item deliverable

³⁾ L = light series; ⁴⁾ S = heavy series

$$\frac{\text{PN (bar)}}{10} = \text{PN (MPa)}$$

Delivery without nut and ring. Information on ordering complete fittings or alternative sealing materials see page I7.

*Please add the **suffixes** below according to the material/ surface required.

Order code suffixes			
Material	Suffix surface and material	Example	Standard sealing material (no additional suffix needed)
Steel, zinc yellow plated	A3C	DVWE06LMOMDA3C	NBR
FKM (Viton)	A3C VIT	DVWE06LMOMDVITA3C	

Port tapping for plain bearing rotary fittings DVGE and DVWE

Port tapping form X
according to DIN 3852, part 1 and part 2
(for parallel male studs)

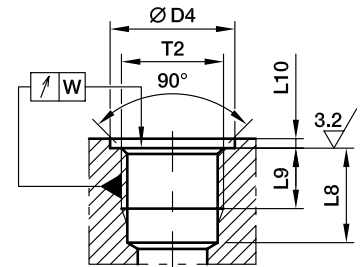

Thread d1	d ₄ small +0.4	a ₁ max	b ₁ min	L ₈ min	W
M 14 1.5	20	1.5	12	19.0	0.1
M 18 1.5	25 ²⁾	2.0	12	19.0	0.1
M 22 1.5	28	2.5	14	22.0	0.1
M 27 2	33	2.5	16	25.0	0.2
M 33 2	41 ²⁾	2.5	18	28.5	0.2
M 42 2	51 ²⁾	2.5	20	32.0	0.2
M 48 2	56	2.5	22	36.0	0.2
G 1/4 A	20 ²⁾	1.5	12	19.0	0.1
G 3/8 A	23	2.0	12	19.0	0.1
G 1/2 A	28 ²⁾	2.5	14	22.0	0.1
G 3/4 A	33	2.5	16	25.0	0.2
G 1 A	41 ²⁾	2.5	18	28.5	0.2
G 1 1/4 A	51 ²⁾	2.5	20	32.0	0.2
G 1 1/2 A	56	2.5	22	36.0	0.2

¹⁾ Not in DIN 3852



²⁾ Different from DIN 3852



SensoControl[®] ***Diagnostic*** ***equipment*** ***Test Points***

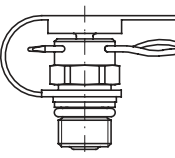
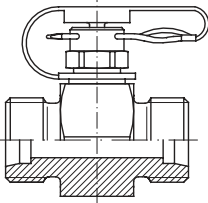
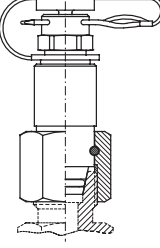
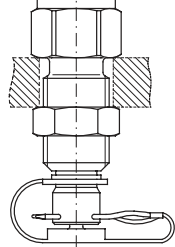
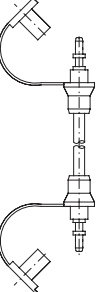
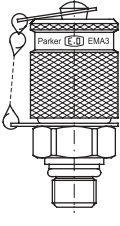
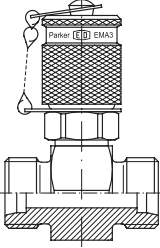

Visual index

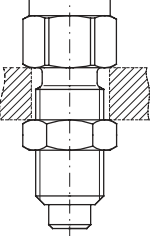
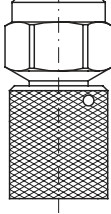
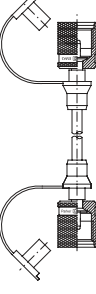
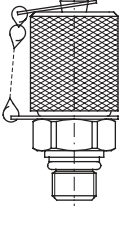
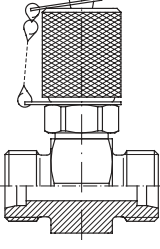
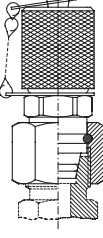
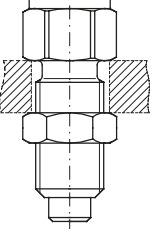
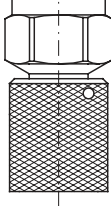
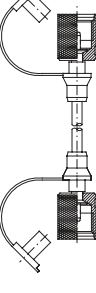
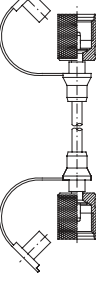
<p>Series 1 Test point fitting with pin-lock</p>						
<p>Series 3 Test point with threaded connection M 16x2</p>						
<p>Series 4 Test point with threaded connection M 16x1.5</p>						
<p>SensoControl® Product range Diagnostic/ Industrial</p>	<p>p. Q16</p>					

EMA1/EMA3/EMA4-Test Point fitting

- For pressure monitoring and checking on high, low and negative pressure systems.
- For bleeding cylinders and hydraulic systems.
- For taking samples on high, low and negative pressure systems.

Advantages:

- Leakfree connection before valve is open
- Sturdy, safe constructions for small dimensions
- Easy handling
- Simple connection of measuring, control and switching devices
- Coupling under pressure up to 400 bar is possible with screw couplings
- Nominal pressures up to 630 bar
- Self locking metal guard cap, vibration resistant

Sealing system of the primary seal:

EMA1 by ball non-return valve.

EMA3/EMA4 by cone seal with O-ring.

The new EMA3/EMA4 sealing system guarantees minimum leakage rates even for pneumatic and gas applications.

The screw-on Cap (EMA3/EMA4), and pin lock (EMA1) types both employ an O-ring seal as secondary sealing with the hose attached.

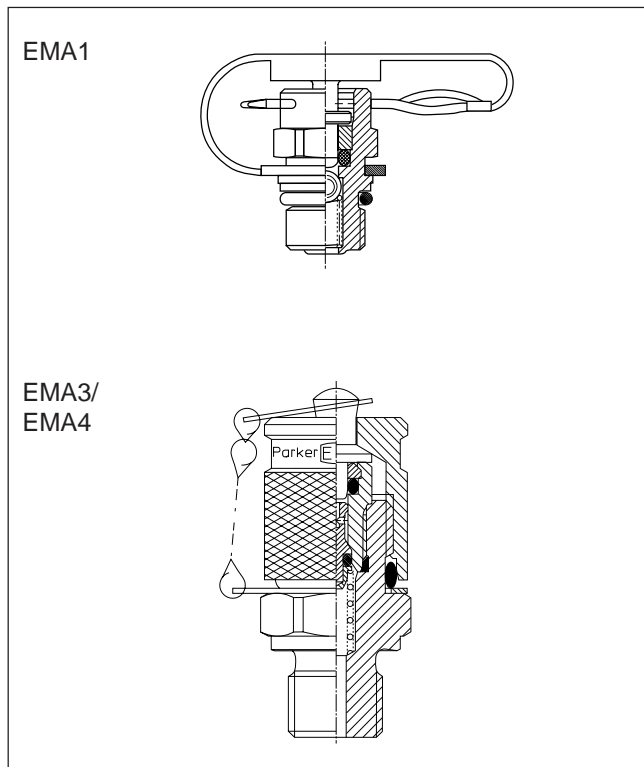

Differences between EMA1, EMA3 and EMA4 types

- sealing system (see previous section)
- Test hose connection by plug-in coupling in EMA1
Test hose connection by threaded connection in EMA3
- Working pressures (see section advantages)

Working pressure

- EMA3/EMA4 types up to 630 bar
- EMA1 types up to 400 bar
- Max. working pressure 630 bar for GMA, VKA and EMA ... the recommended working pressure of fitting manufacturer has to be applied
- Joining under pressure up to 400 bar max.
- The allowable nominal pressures of each Test-Point are shown on the product pages.

Materials and Temperatures:

- Steel, yellow chromated (A3C)
- Stainless Steel, material 1.4571
- Seals:
 - NBR Temperature range -20 to $+100^{\circ}\text{C}$
(The sealing of the poppet valve for Standard-NBR-version is FKM)
 - FKM (Temperature range -20 to $+200^{\circ}\text{C}$)
 - EPDM Ethylene Propylene (for Break Fluid)
(Temperature range -40 to $+150^{\circ}\text{C}$)
- Hose:
 - Polyamide (Temperature range: -35°C ... 100°C max.)

Seals:

- Steel Types NBR (Perbunan)
- Stainless Steel FKM (Viton) only

Media:

- Suitable for hydraulic oils and other mineral oil based fluids (Please pay attention to the sealing materials used!)
- For use in conjunction with other liquid media please consult Parker

Approvals

DVGW for EMA3/8X1OR, EMA3/10X1OR, EMA3 1/8NPT, EMA 3 1/4 NPT



EMA1 Test point fitting with pin-lock

Series 1

Male stud thread: BSP, metric

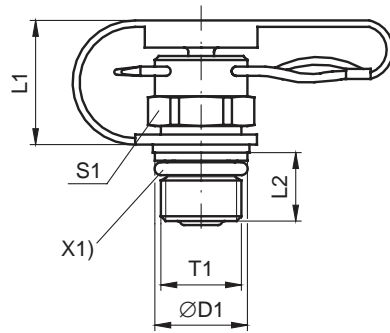

Fig. A

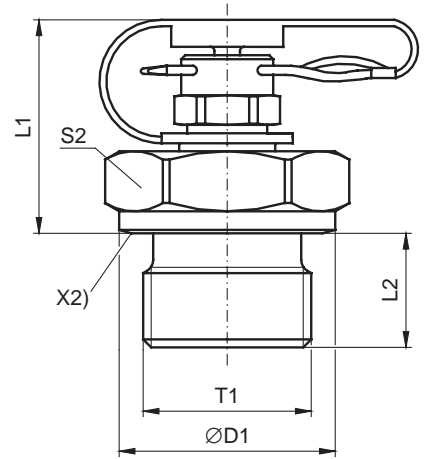

Fig. B

X1) O-ring
X2) Cutting face

T1	D1	L1	L2	S1	S2	Fig.	Weight g/1 piece	Order code*	PN (bar) ¹⁾ A3C	DF**
M12×1.5	17.0	32.0	12.0		19	B	53	EMA1/12X1.5	400	4
M14×1.5	19.0	32.0	12.0		19	B	56	EMA1/14X1.5	400	4
M16×1.5	21.0	25.0	12.0		22	B	47	EMA1/16X1.5	400	4
G1/8	14.0	32.5	8.0		17	B	41	EMA1/1/8	400	4
G1/4	18.0	32.0	12.0		19	B	54	EMA1/1/4	400	4
G3/8	22.0	27.5	12.0		22	B	55	EMA1/3/8	400	4
G1/2	26.0	27.5	14.0		27	B	78	EMA1/1/2	400	4
M8×1	9.5	17.5	8.4	12		A	16	EMA1/8X1OR	400	4
M10×1	11.5	18.0	8.0	12		A	18	EMA1/10X1OR	400	4
M10×1	14.0	32.5	8.0		17	B	42	EMA1/10X1	400	4

**DF = Design Factor

¹⁾ Pressure shown = item deliverable

$$\frac{PN \text{ (bar)}}{10} = PN \text{ (MPa)}$$

*Please add the **suffixes** below according to the material/surface required.

Order code suffixes			
Material	Suffix surface and material	Example	Standard sealing material (no additional suffix needed)
Steel, zinc plated	A3C	EMA1/12X1.5A3C	NBR

GMA1 Straight test point fitting with pin-lock

Series 1

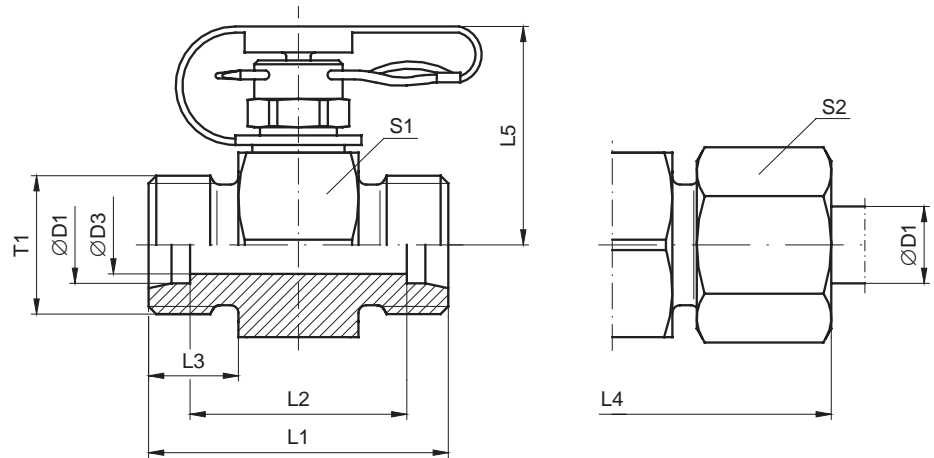

Series	D1	T1	D3	L1	L2	L3	L4	L5	S1	S2	Weight g/1 piece	Order code	PN (bar) ¹⁾ A3C	DF ²⁾
L ³⁾	06	M12×1.5	4	35	21	10	51	29.0	24	14	73	GMA1/06LOMD	315	4
	08	M14×1.5	6	35	21	10	51	29.0	24	17	75	GMA1/08LOMD	315	4
	10	M16×1.5	7	37	23	11	53	29.0	24	19	80	GMA1/10LOMD	315	4
	12	M18×1.5	10	37	23	11	53	30.5	27	22	96	GMA1/12LOMD	315	4
	15	M22×1.5	12	39	25	12	55	32.0	30	27	121	GMA1/15LOMD	315	4
	18	M26×1.5	15	39	24	12	57	33.0	32	32	139	GMA1/18LOMD	315	4
22	M30×2	19	43	28	14	61	35.0	36	36	171	GMA1/22LOMD	160	4	
S ⁴⁾	06	M14×1.5	4	39	25	12	55	29.0	24	17	82	GMA1/06SOMD	400	4
	08	M16×1.5	5	39	25	12	55	29.0	24	19	88	GMA1/08SOMD	400	4
	10	M18×1.5	7	39	24	12	57	29.0	24	22	90	GMA1/10SOMD	400	4
	12	M20×1.5	7	39	24	12	57	29.0	24	24	96	GMA1/12SOMD	400	4
	14	M22×1.5	10	43	27	14	63	30.5	27	27	121	GMA1/14SOMD	400	4
	16	M24×1.5	12	43	26	14	63	32.0	30	30	138	GMA1/16SOMD	400	4
	20	M30×2	16	47	26	16	69	35.0	36	36	222	GMA1/20SOMD	400	4

**DF = Design Factor

1) Pressure shown = item deliverable

3) L = light series; *) S = heavy series

$$\frac{\text{PN (bar)}}{10} = \text{PN (MPa)}$$

Delivery without nut and ring. Information on ordering complete fittings or alternative sealing materials see page I7.

*Please add the **suffixes** below according to the material/surface required.

Order code suffixes			
Material	Suffix surface and material	Example	Standard sealing material (no additional suffix needed)
Steel, zinc plated	A3C	GMA1/06LOMDA3C	NBR



VKA1 Test point fitting with pin lock for cones

Series 1

With 24° cone swivel nut connection

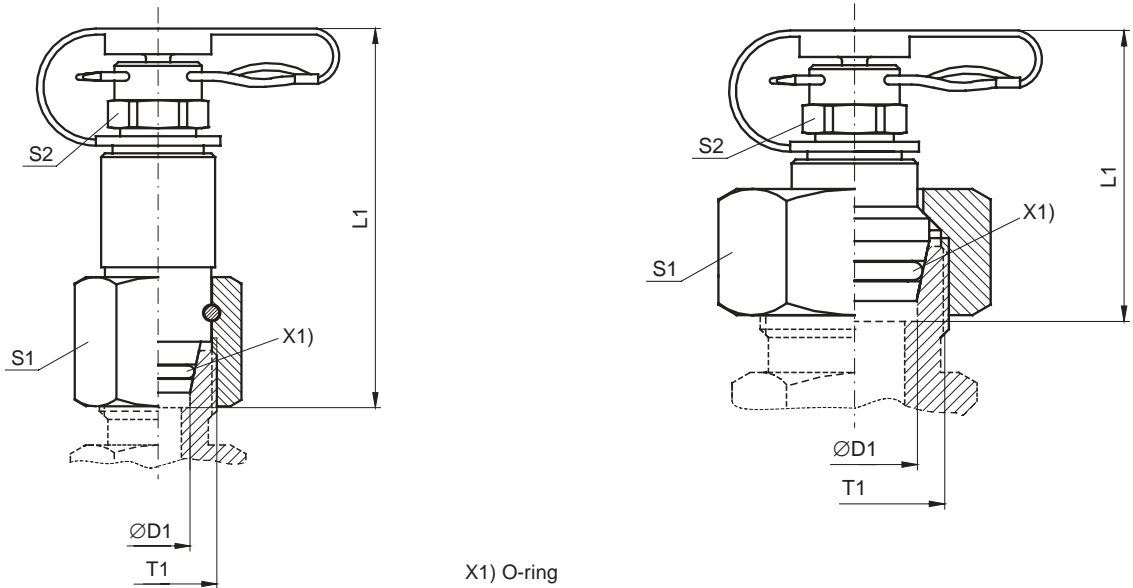

X1) O-ring

Series	D1	T1	L1	S1	S2	Fig.	Weight g/1 piece	Order code*	PN (bar) ¹⁾ A3C	DF**
L ³⁾	06	M12×1.5	48	14	12	A	44	VKA1/06L	315	4
	08	M14×1.5	49	17	12	A	54	VKA1/08L	315	4
	10	M16×1.5	50	19	12	A	68	VKA1/10L	315	4
	12	M18×1.5	51	22	12	A	81	VKA1/12L	315	4
	15	M22×1.5	39	27	12	B	82	VKA1/15L	315	4
	18	M26×1.5	38	32	12	B	112	VKA1/18L	315	4
S ⁴⁾	06	M14×1.5	48	17	12	A	51	VKA1/06S	400	4
	08	M16×1.5	50	19	12	A	62	VKA1/08S	400	4
	10	M18×1.5	50	22	12	A	78	VKA1/10S	400	4
	12	M20×1.5	51	24	12	A	100	VKA1/12S	400	4
	14	M22×1.5	39	27	12	B	88	VKA1/14S	400	4
	16	M24×1.5	37	30	12	B	105	VKA1/16S	400	4
	20	M30×2	44	36	12	B	174	VKA1/20S	400	4

**DF = Design Factor

¹⁾ Pressure shown = item deliverable

³⁾ L = light series; ⁴⁾ S = heavy series

$$\frac{\text{PN (bar)}}{10} = \text{PN (MPa)}$$

*Please add the **suffixes** below according to the material/surface required.

Order code suffixes			
Material	Suffix surface and material	Example	Standard sealing material (no additional suffix needed)
Steel, zinc plated	A3C	VKA1/06LA3C	NBR

MAV-MA1 SMA1 Test Point pressure gauge connector with pin-lock
Test Point high pressure hose with pin-lock **Series 1**

Female thread: BSP
 Sealing: sealing ring DIN 16258

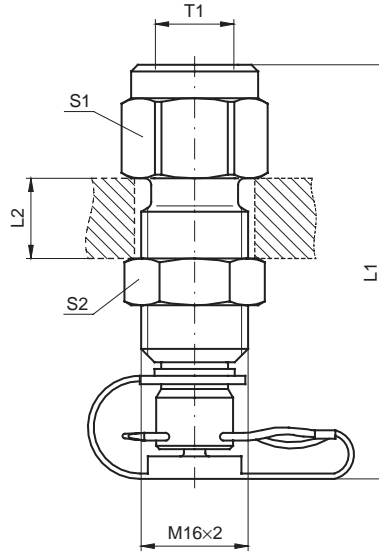

Pressure gauge connector: MAV-MA1

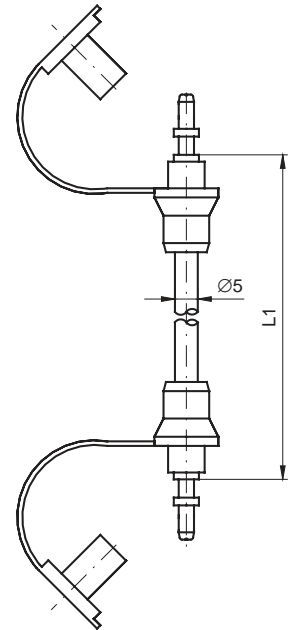

Test hose: SMA1

T1	L1	L2 max.	S1	S2	Weight g/1 piece	Order code*	PN (bar) ¹⁾ A3C	DF**
G1/4	61.5	12	19	19	78	MAV1/4MA1	400	4.0
G1/2	72.0	12	27	19	135	MAV1/2MA1	400	4.0
	400.0				21	SMA1-400	400	2.5
	630.0				26	SMA1-630	400	2.5
	800.0				26	SMA1-800	400	2.5
	1000.0				31	SMA1-1000	400	2.5
	1500.0				40	SMA1-1500	400	2.5
	2000.0				49	SMA1-2000	400	2.5
	2500.0				58	SMA1-2500	400	2.5
	3200.0				70	SMA1-3200	400	2.5
	4000.0				84	SMA1-4000	400	2.5

**DF = Design Factor

¹⁾ Pressure shown = item deliverable

$$\frac{PN \text{ (bar)}}{10} = PN \text{ (MPa)}$$

*Please add the **suffixes** below according to the material/surface required.

Order code suffixes			
Material	Suffix surface and material	Example	Standard sealing material (no additional suffix needed)
Steel, zinc plated	A3C	MAV1/4MA1A3C	NBR

Note hoses with small diameter:

- Min. bending radius r = 20 mm
- Working temperature -20°C up to 100°C (short time to +120°C)
- Hoses are to be protected from fire, from sharp-corners and hot objects.

Temperature factor of pressure rating:

up to 0° C	122 %
for 30° C	110 %
for 50° C	100 %
for 80° C	86 %
for 100° C	77 %

For measuring with liquid pressure media please note:
 Bleed before connecting tube! By capillary action discharge of the pressure medium is prevented widely.



EMA3 Test Point with threaded connection M 16×2

Series 3

Male thread: BSP, metric

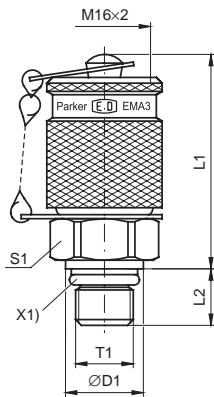

Fig. A

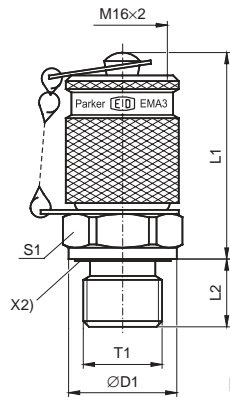

Fig. B

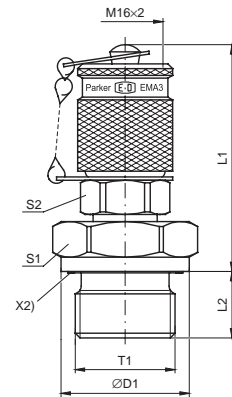

Fig. C

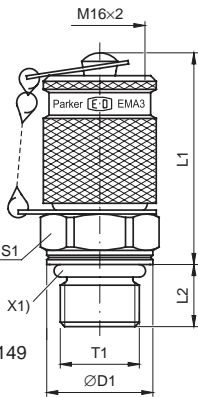

Fig. F

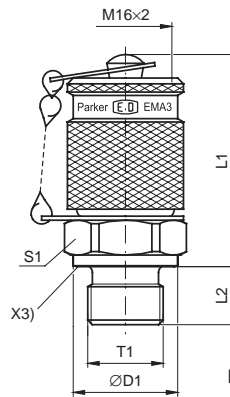

Fig. D

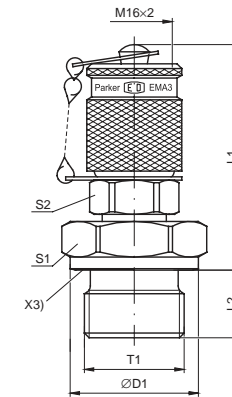

Fig. E

X1) O-ring
X2) Eolastic sealing
X3) Cutting face

T1	D1	L1	L2	S1	S2	Fig.	Weight g/1 piece	Order code*	PN (bar) ¹⁾		DF ^{**}	
									A3C	71	A3C	71
M8×1	9.5	37.0	8.5	17		A	66	EMA3/8X1OR	250		4.0	
M10×1	11.5	37.5	9.8	17		A	70	EMA3/10X1OR	630	630	4.0	4
M14×1.5	18.8	38.0	11.0	19		F	79	EMA3/14X1.5ISO	630	630	4.0	4
M10×1	14.0	37.0	8.0	17		D	67	EMA3/10X1	400		4.0	
M12×1.5	17.0	37.0	12.0	17		D	74	EMA3/12X1.5	400		4.0	
M14×1.5	19.0	37.0	12.0	19		D	78	EMA3/14X1.5	400		4.0	
M16×1.5	21.0	37.0	12.0	22		D	90	EMA3/16X1.5	400		4.0	
G1/8	14.0	39.0	8.0	17		D	70	EMA3/1/8	400		4.0	
G1/4	18.0	37.0	12.0	19		D	77	EMA3/1/4	400		4.0	
G3/8	22.0	37.0	12.0	22		D	91	EMA3/3/8	400		4.0	
G1/2	26.0	49.0	14.0	27	17	E	137	EMA3/1/2	400		3.4	
G1/8	14.0	39.0	8.0	17		B	72	EMA3/1/8ED	400	400	4.0	4
G1/4	19.0	37.0	12.0	19		B	76	EMA3/1/4ED	630	630	4.0	4
G3/8	22.0	37.0	12.0	22		B	93	EMA3/3/8ED	630	630	4.0	4
M10×1	14.0	39.0	8.0	17		B	71	EMA3/10X1ED	400	400	4.0	4
M12×1.5	17.0	37.0	12.0	17		B	72	EMA3/12X1.5ED	630	630	4.0	4
M14×1.5	19.0	37.0	12.0	19		B	77	EMA3/14X1.5ED	400	400	4.0	4
G1/2	27.0	49.0	14.0	27	17	C	135	EMA3/1/2ED	400	400	4.0	4

**DF = Design Factor

¹⁾ Pressure shown = item deliverable

$$\frac{PN \text{ (bar)}}{10} = PN \text{ (MPa)}$$

*Please add the **suffixes** below according to the material/ surface required.

Order code suffixes			
Material	Suffix surface and material	Example	Standard sealing material (no additional suffix needed)
Steel, zinc plated	A3C	EMA3/10X10ORA3C	NBR

GMA3 Straight Test Point with threaded connection M 16×2

Series 3

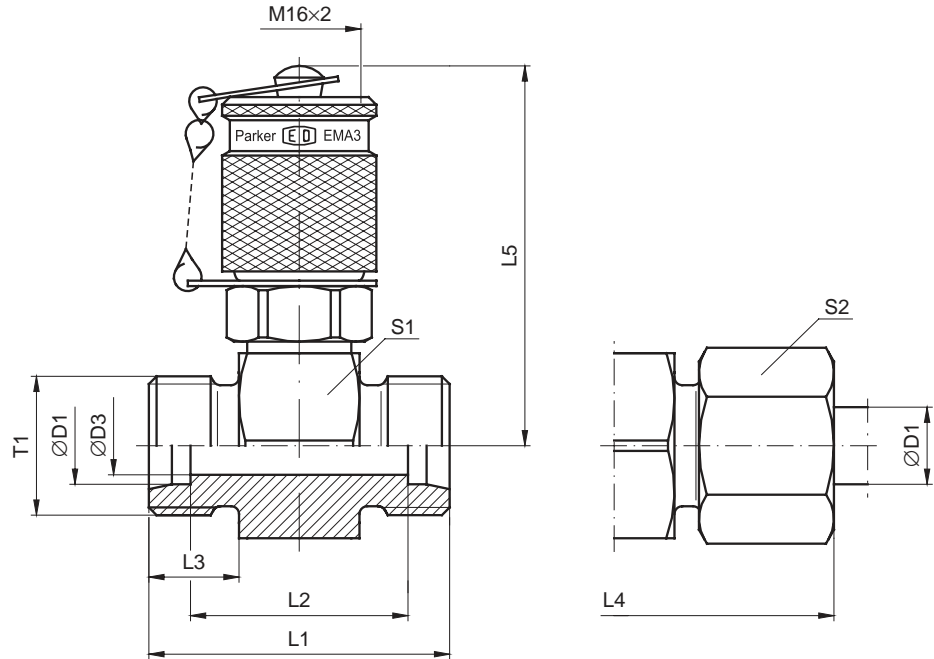

Series	D1	T1	D3	L1	L2	L3	L4	L5	S1	S2	Weight g/1 piece	Order code*	PN (bar) ¹⁾		DF**	
													A3C	71	A3C	71
L ³⁾	06	M12×1.5	4	35	21	10	51	49	24	14	126	GMA3/06LOMD	315	315	4	4
	08	M14×1.5	6	35	21	10	51	49	24	17	128	GMA3/08LOMD	315	315	4	4
	10	M16×1.5	7	37	23	11	53	49	24	19	132	GMA3/10LOMD	315	315	4	4
	12	M18×1.5	10	37	23	11	53	50	27	22	145	GMA3/12LOMD	315	315	4	4
	15	M22×1.5	12	39	25	12	55	52	30	27	174	GMA3/15LOMD	315	315	4	4
	18	M26×1.5	15	39	24	12	57	53	32	32	192	GMA3/18LOMD	315	315	4	4
	22	M30×2	19	43	28	14	61	55	36	36	220	GMA3/22LOMD	160	160	4	4
	28	M36×2	24	43	28	14	61	57	41	41	259	GMA3/28LOMD	160	160	4	4
	35	M45×2	29	47	26	16	69	60	46	50	363	GMA3/35LOMD	160	160	4	4
	42	M52×2	36	47	25	16	71	64	55	60	419	GMA3/42LOMD	160	160	4	4
S ⁴⁾	06	M14×1.5	4	39	25	12	55	49	24	17	137	GMA3/06SOMD	630	630	4	4
	08	M16×1.5	5	39	25	12	55	49	24	19	141	GMA3/08SOMD	630	630	4	4
	10	M18×1.5	7	39	24	12	57	49	24	22	141	GMA3/10SOMD	630	630	4	4
	12	M20×1.5	7	39	24	12	57	49	24	24	150	GMA3/12SOMD	630	630	4	4
	14	M22×1.5	10	43	27	14	63	50	27	27	172	GMA3/14SOMD	630	630	4	4
	16	M24×1.5	12	43	26	14	63	52	30	30	195	GMA3/16SOMD	400	400	4	4
	20	M30×2	16	47	26	16	69	55	36	36	254	GMA3/20SOMD	400	400	4	4
	25	M36×2	20	51	27	18	75	57	41	46	329	GMA3/25SOMD	400	400	4	4
	30	M42×2	25	55	28	20	81	60	46	50	412	GMA3/30SOMD	400	400	4	4
	38	M52×2	32	61	29	22	91	64	55	60	616	GMA3/38SOMD	315	315	4	4

**DF = Design Factor

¹⁾ Pressure shown = item deliverable

³⁾ L = light series; ⁴⁾ S = heavy series

$$\frac{PN \text{ (bar)}}{10} = PN \text{ (MPa)}$$

Delivery without nut and ring. Information on ordering complete fittings or alternative sealing materials see page 17.

*Please add the **suffixes** below according to the material/surface required.

Order code suffixes			
Material	Suffix surface and material	Example	Standard sealing material (no additional suffix needed)
Steel, zinc plated	A3C	GMA3/06LOMDA3C	NBR
Stainless Steel	71	GMA3/06LOMD71	VIT

VKA3 Test Point for cones with threaded connection M 16×2

Series 3

With 24° cone swivel nut connection

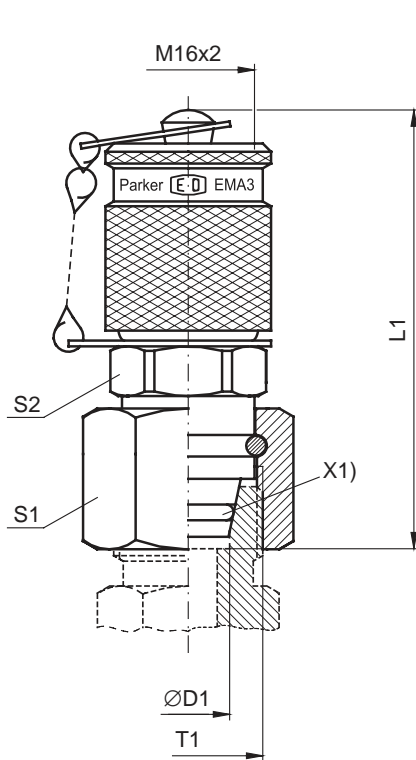

Fig. A

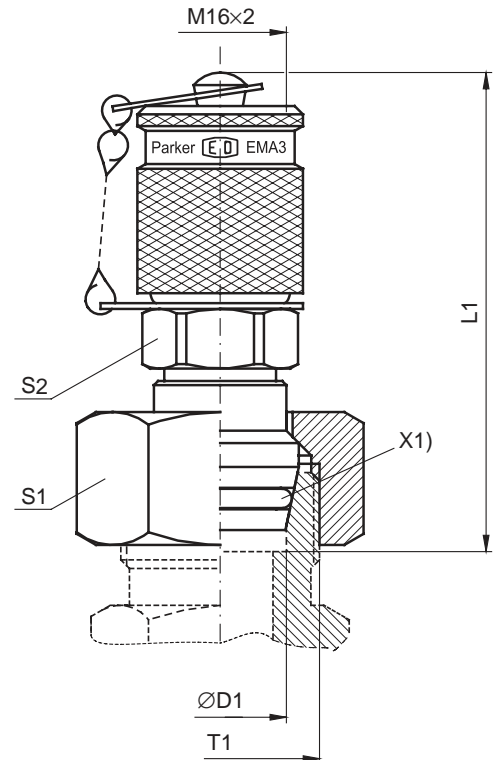

Fig. B

X1) O-ring

Series	D1	T1	L1	S1	S2	Fig.	Weight g/1 piece	Order code*	PN (bar) ¹⁾		DF**	
									A3C	71	A3C	71
L ³⁾	06	M12×1.5	55	14	17	A	82	VKA3/06L	315	315	4	4
	08	M14×1.5	51	17	17	A	82	VKA3/08L	315	315	4	4
	10	M16×1.5	53	19	17	A	93	VKA3/10L	315	315	4	4
	12	M18×1.5	53	22	17	A	107	VKA3/12L	315	315	4	4
	15	M22×1.5	59	27	17	B	133	VKA3/15L	315	315	4	4
	18	M26×1.5	59	32	17	B	163	VKA3/18L	315	315	4	4
	22	M30×2	60	36	17	B	205	VKA3/22L	160	160	4	4
	28	M36×2	64	41	17	B	269	VKA3/28L	160	160	4	4
	35	M45×2	71	50	17	B	411	VKA3/35L	160	160	4	4
42	M52×2	72	60	17	B	592	VKA3/42L	160	160	4	4	
S ⁴⁾	06	M14×1.5	50	17	17	A	81	VKA3/06S	630	630	4	4
	08	M16×1.5	52	19	17	A	88	VKA3/08S	630	630	4	4
	10	M18×1.5	53	22	17	A	99	VKA3/10S	630	630	4	4
	12	M20×1.5	54	24	19	A	121	VKA3/12S	630	630	4	4
	14	M22×1.5	59	27	17	B	136	VKA3/14S	630	630	4	4
	16	M24×1.5	58	30	17	B	156	VKA3/16S	400	400	4	4
	20	M30×2	65	36	17	B	223	VKA3/20S	400	400	4	4
	25	M36×2	68	46	17	B	367	VKA3/25S	400	400	4	4
	30	M42×2	74	50	17	B	444	VKA3/30S	400	400	4	4
38	M52×2	81	60	17	B	655	VKA3/38S	315	315	4	4	

**DF = Design Factor

¹⁾ Pressure shown = item deliverable

³⁾ L = light series; ⁴⁾ S = heavy series

$\frac{PN \text{ (bar)}}{10} = PN \text{ (MPa)}$

*Please add the **suffixes** below according to the material/surface required.

Order code suffixes			
Material	Suffix surface and material	Example	Standard sealing material (no additional suffix needed)
Steel, zinc plated	A3C	VKA3/06LA3C	NBR

MAV...MA3 Test point pressure gauge connector with threaded connection M 16×2
MAVMD...MA3 Test point with threaded connection M 16×2
SMA3 Test point high pressure hose with threaded connection M 16×2 W Series 3

Female thread: BSP
 Sealing: sealing ring DIN 16258*

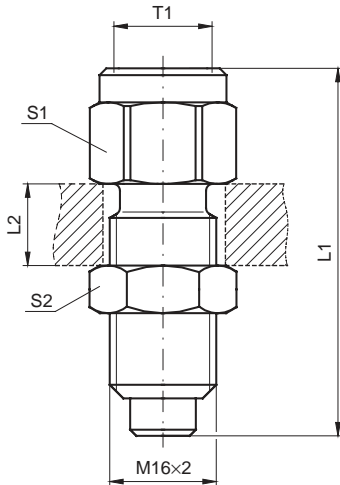

Pressure gauge connector:
MAV...MA3

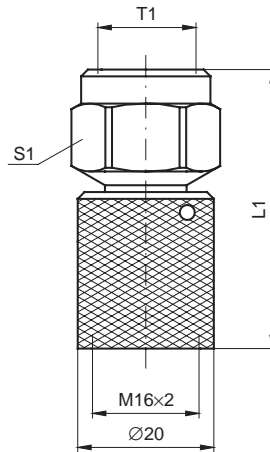

Gauge-Direct-Connector:
MAVMD...MA3

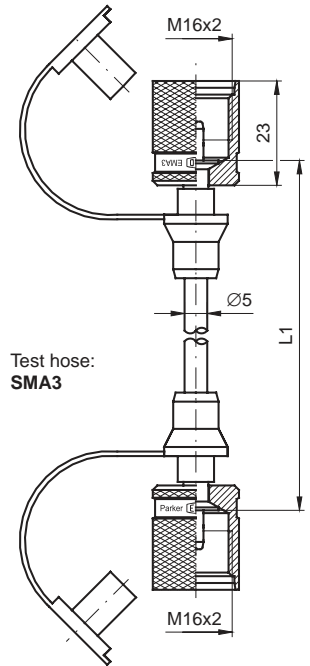

Test hose:
SMA3

T1	L1	L2 max.	S1	S2	Weight g/1 piece	Order code*	PN (bar) ¹⁾ A3C	DF**
G1/4	54.0	12	19	19	74	MAV1/4MA3	630	4.0
G1/2	64.0	12	27	19	129	MAV1/2MA3	630	4.0
G1/4	41.0		19		61	MAVMD1/4MA3	630	4.0
G1/2	51.5		27		103	MAVMD1/2MA3	630	4.0
	200.0				73	SMA3-200	630	2.5
	300.0				74	SMA3-300	630	2.5
	400.0				74	SMA3-400	630	2.5
	630.0				79	SMA3-630	630	2.5
	800.0				83	SMA3-800	630	2.5
	1000.0				87	SMA3-1000	630	2.5
	1500.0				95	SMA3-1500	630	2.5
	2000.0				105	SMA3-2000	630	2.5
	2500.0				110	SMA3-2500	630	2.5
	3200.0				125	SMA3-3200	630	2.5
	4000.0				137	SMA3-4000	630	2.5

**DF = Design Factor

¹⁾ Pressure shown = item deliverable

$$\frac{PN \text{ (bar)}}{10} = PN \text{ (MPa)}$$

*Please add the **suffixes** below according to the material/ surface required.

Order code suffixes			
Material	Suffix surface and material	Example	Standard sealing material (no additional suffix needed)
Steel, zinc plated	A3C	MAV1/4MA3A3C	NBR

* Sealing rings according to DIN 16258 for steel design of copper, for stainless steel design of stainless steel.

Note hoses with small diameter:

- Min. bending radius r = 20 mm
- Working temperature -20°C up to 100°C (short time to +120°C)
- Hoses are to be protected from fire, from sharp-corners and hot objects.

For measuring with liquid pressure media please note: Bleed before connecting tube! By capillary action discharge of the pressure medium is prevented widely.

Temperature factor of pressure rating:

up to 0° C	122 %
for 30° C	110 %
for 50° C	100 %
for 80° C	86 %
for 100° C	77 %



EMA4 Test Point with threaded connection M 16×1.5

Series 4

Male thread: BSP, metric

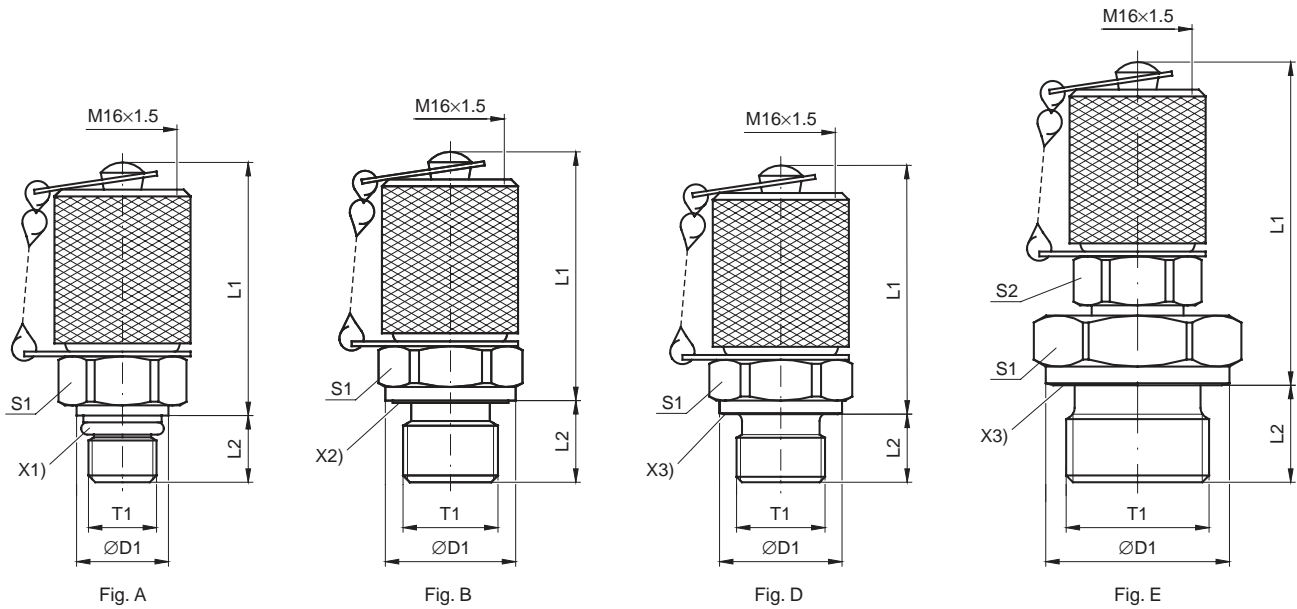

- X1) O-ring
- X2) Eolastic sealing
- X3) Cutting face

T1	D1	L1	L2	S1	S2	Fig.	Weight g/1 piece	Order code*	PN (bar) ¹⁾		DF**	
									A3C	71	A3C	71
M10×1	11.5	37.5	9.8	17		A	66	EMA4/10X1OR	630	630	4	4
M12×1.5	17.0	37.0	12.0	17		D	116	EMA4/12X1.5	400	400	4	4
M14×1.5	19.0	37.0	12.0	19		D	78	EMA4/14X1.5	400		4	
M16×1.5	21.0	37.0	12.0	22		D	140	EMA4/16X1.5	400		4	
G1/4	18.0	37.0	12.0	19		D	77	EMA4/1/4	400		4	
G3/8	22.0	59.0	12.0	22	19	E	141	EMA4/3/8	400		4	
G1/2	26.0	49.0	14.0	27	17	E	129	EMA4/1/2	400		4	
G1/4	19.0	37.0	12.0	19		B	82	EMA4/1/4ED	630	630	4	4

**DF = Design Factor

¹⁾ Pressure shown = item deliverable

$$\frac{\text{PN (bar)}}{10} = \text{PN (MPa)}$$

*Please add the **suffixes** below according to the material/ surface required.

Order code suffixes			
Material	Suffix surface and material	Example	Standard sealing material (no additional suffix needed)
Steel, zinc plated	A3C	EMA4/10X1ORA3C	NBR
Stainless Steel	71	EMA4/10XOR71	VIT

GMA4 Straight Test Point with threaded connection M 16×1.5

Series 4

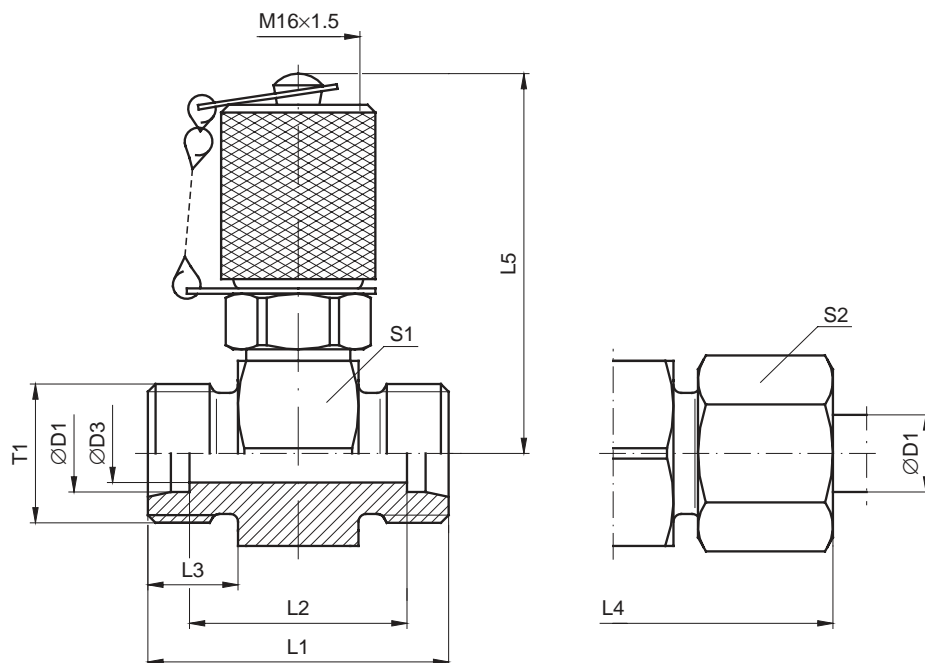

Series	D1	T1	D3	L1	L2	L3	L4	L5	S1	S2	Weight g/1 piece	Order code*	PN (bar) ¹⁾		DF**	
													A3C	71	A3C	71
S ⁴⁾	08	M16×1.5	5	39	25	12	55	49	24	19	141	GMA4/08SOMD	630	630	4	4
	10	M18×1.5	7	39	24	12	57	49	24	22	141	GMA4/10SOMD	630	630	4	4
	12	M20×1.5	7	39	24	12	57	49	24	24	150	GMA4/12SOMD	630	630	4	4
	14	M22×1.5	10	43	27	14	63	50	27	27	172	GMA4/14SOMD	630	630	4	4
	16	M24×1.5	12	43	26	14	63	52	30	30	195	GMA4/16SOMD	400	400	4	4
	20	M30×2	16	47	26	16	69	55	36	36	254	GMA4/20SOMD	400	400	4	4

**DF = Design Factor
Other sizes on request

¹⁾ Pressure shown = item deliverable

⁴⁾ S = heavy series

$$\frac{\text{PN (bar)}}{10} = \text{PN (MPa)}$$

Delivery without nut and ring. Information on ordering complete fittings or alternative sealing materials see page 17.

*Please add the **suffixes** below according to the material/surface required.

Order code suffixes			
Material	Suffix surface and material	Example	Standard sealing material (no additional suffix needed)
Stainless Steel	A3C	GMA4/08SLOMD71	VIT



VKA4 test point for cones with threaded connection M 16×1.5 Series 4

With 24° cone swivel nut connection

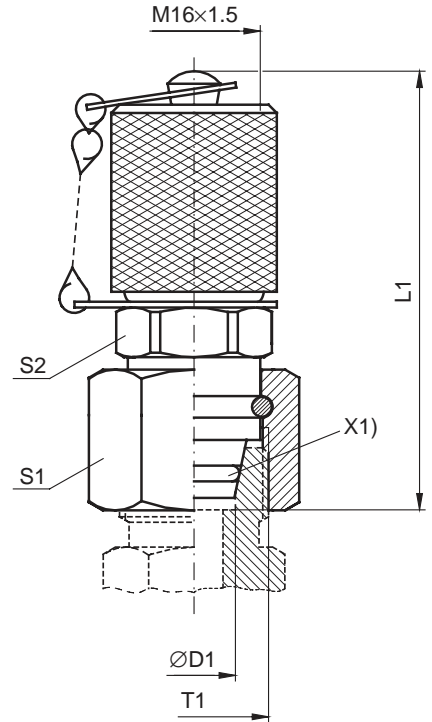

X1) O-ring

Fig. A

Series	D1	T1	L1	S1	S2	Fig.	Weight g/1 piece	Order code*	PN (bar) ¹⁾ A3C	DF ^{**}
S ⁴⁾	12	M20×1.5	54	24	19	A	121	VKA4/12S	630	4

**DF = Design Factor
Other sizes on request

¹⁾ Pressure shown = item deliverable

⁴⁾ S = heavy series

$$\frac{\text{PN (bar)}}{10} = \text{PN (MPa)}$$

*Please add the **suffixes**
below according to the material/
surface required.

Order code suffixes			
Material	Suffix surface and material	Example	Standard sealing material (no additional suffix needed)
Steel, zinc plated	A3C	VKA4/12SA3C	NBR

MAV...MA4 Test point pressure gauge connector with threaded connection M 16×1.5
MAVMD...MA4 Test point with threaded connection M 16×1.5
SMA4 Test point high pressure hose with threaded connection M 16×1.5 Series 4

Female thread: BSP
 Sealing: sealing ring DIN 16258*

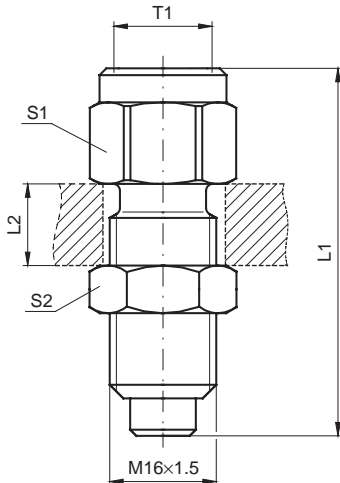

Pressure gauge connector:
MAV...MA4

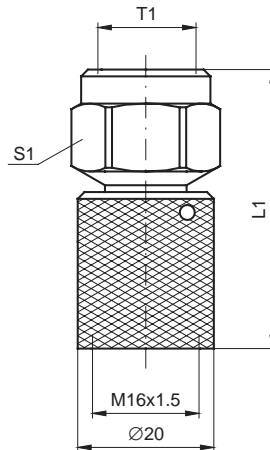

Gauge-Direct-Connector:
MAVMD...MA4

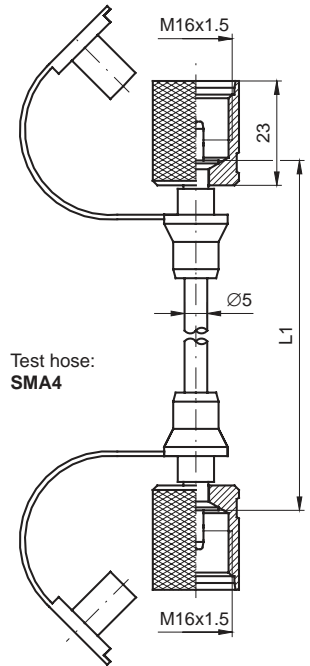

Test hose:
SMA4

T1	L1	L2 max	S1	S2	Weight g/1 piece	Order code*	PN (bar) ¹⁾		DF **	
							A3C	71	A3C	71
G1/4	54.0	12	19	19	74	MAV1/4MA4	630		4.0	
G1/2	64.0	12	27	19	129	MAV1/2MA4	630		4.0	
G1/4	41.0		19		61	MAVMD1/4MA4	630		4.0	
G1/2	51.5		27		103	MAVMD1/2MA4	630		4.0	
	400.0				74	SMA4-400	630		2.5	
	630.0				79	SMA4-630	630		2.5	
	800.0				83	SMA4-800	630		2.5	
	1000.0				87	SMA4-1000	630	630	2.5	2.5
	1500.0				95	SMA4-1500		630	2.5	2.5
	2000.0				105	SMA4-2000	630		2.5	
	4000.0				137	SMA4-4000		630	2.5	

**DF = Design Factor

¹⁾ Pressure shown = item deliverable

$$\frac{PN \text{ (bar)}}{10} = PN \text{ (MPa)}$$

*Please add the **suffixes**
 below according to the material/
 surface required.

Order code suffixes			
Material	Suffix surface and material	Example	Standard sealing material (no additional suffix needed)
Steel, zinc plated	A3C	SMA4-1000A3C	NBR
Stainless Steel	71	SMA4-100071	VIT

* Sealing rings according to DIN 16258 for steel design of copper, for stainless steel design of stainless steel.

Note pressure hoses SMA4:

- Min. bending radius r = 20 mm
- Working temperature -20°C up to 100°C (short time to +120°C)
- Hoses are to be protected from fire, from sharp-corners and hot objects.

For measuring with liquid pressure media please note:
 Bleed before connecting tube!

Temperature factor of pressure rating:

up to 0° C	122 %
for 30° C	110 %
for 50° C	100 %
for 80° C	86 %
for 100° C	77 %



SensoControl®

ServiceJunior



Hand-held measuring devices

ServiceJunior: Perfect and simple measuring. On top of easy operating capturing pressure peaks in hydraulic system can be done immediately.

Measuring and displaying pressure very precisely due to 4 digit display. Pressure peaks captured by displaying MAX reading.

ServiceJunior is powered by a battery.

Complete ServiceJunior Kit

- incl. Test Point Adapters and Test Hoses
- Ready to start

Data sheet 4052/D1/UK!

SensoControl®

Serviceman Series



The **SensoControl®** Serviceman Kits (SC-500-01, SC-510-01) are basic equipment to measure pressure, temperature, flow and rotational speed in hydraulics. Simple to operate; particularly suitable for on-site use.

All **SensoControl®** handmeters are provided with sensor recognition. The measuring ranges are automatically scaled and shown on the display. This prevents measuring errors and makes time-consuming adjustment work unnecessary.

Please ask for catalogue no. 4087!

SensoControl®

ServiceMaster Series



The **ServiceMaster** is a multi-channel handmeter for the simultaneous measuring of important hydraulic values: **all hydraulic parameters, such as pressure, differential pressure, flow and hydraulic power can be measured, displayed, stored and processed.**



SCKIT-250/350 – Basic and extended Kits in order to measure up to 3 hydraulic datas simultaneously.

SensoControl®

ServiceMaster Series



SensoControl® handmeters and complete measuring systems are perfectly suited measuring tools for every application. Whether they are used in the industrial area, in mobile hydraulics, for service or repair: measuring and processing of hydraulic values is the basis of safe trouble shooting. The systematic search of errors with modern means is something the service engineer simply cannot do without.



To meet the requirements in both modern industrial hydraulics and complex mobile hydraulics, we offer a range of different models.

SCKIT-400/450 – Advanced Kits for complete diagnosis including software and printer. Up to 6 channels can be measured, displayed and analyzed.

SensoControl®

Pressure Controller SCPSD



Easy handling, high functionality and longterm stability service life are the main characteristics of the electronic Pressure Controller SCPSD.

Features:

- Bar/PSI/MPa
- compact design
- can be swivelled
- robust housing (IP 67)
- easy operation
- 2 switching outputs
- 4 limit values
- adjustable analogue output
- delay times (damping)
- hysteresis/window function
- password

If the pressure is to be displayed, or if rapid switching or analogue signals, which have to be adjusted simply and without additional calibration, are required, then the SCPSD is the ideal solution.

SensoControl®

Temperature Controller SCTSD



Easy operation and high functionality are the main characteristics from the electronic Temperature Controller SCTSD.

Features:

- °C und °F
- compact design
- can be swivelled
- robust housing (IP 67)
- easy operation
- 2 switching outputs
- 4 limit values
- adjustable analogue output
- delay times (damping)
- hysteresis/window function
- password

If the temperature is to be displayed or temperature-dependent switching or analogue signals, which need to be adjusted simply and without additional calibration, are required, then the SCTSD is the ideal solution.

SensoControl®

Temperature sensor SCT



Compact design and high working pressure are the characteristics of the electronic temperature sensor SCT.

Features:

- working pressure up to 630 bar
- compact design
- stainless steel housing
- easy set-up
- -50°C to 250°C
- 0/4 ... 20 mA

If temperatures are to be measured at higher pressures and if a compact design is needed, then the SCT is used.

SensoControl®

Pressure sensors SCP/SCPT



Longterm stability, robust compact housing and protection from interference are the main characteristics of the electronic pressure sensor SCP.

Features:

- long term stability
- stainless steel housing
- G 1/2 + G 1/4 BSPP
- compact design
- relative and absolute pressure
- combisensor for pressure and temperature

If pressure is to be captured reliably in the long term and if compact dimensions are needed, the SCP is appropriate. if a temperature signal is additionally required, the combi-sensor is the solution.



SensoControl®

Adaptors SCA



Broad range of measuring points and adaptors in galvanized finish for rapid, clean and simple adaption of sensors and measuring equipment to hydraulic systems. Plug and screw designs with various threads and seal forms are available.

Please ask for our SensoControl® catalogue!

SensoControl®

SCE-020 panel instrument



Plenty of connections, flexible display and many outputs are the main characteristics of panel instrument SCE-020.

Features:

- Inputs: Current
Voltage
Frequency
- Units freely selectable
- Adjustable display range
- Outputs: Switch
Analogue output
- Serial interface: RS 232

To display easily and flexibly various measurement values, panel instrument SCE-020 is used.

SensoControl®

SCE-100 process manager



Plenty of connections, flexible dual display and universal evaluation possibilities are the main characteristics of the Process Manager SCE-100.

Features:

- dual display
- units selectable
- 4 switch outputs
- 8 limit values
- serial interface RS 232
- min. and max. memory
- difference display
- differential switch output
- built-in clock
- password protection

If various measurement values are to be displayed simultaneously and several switch outputs are needed, the process Manager SCE 100 is used (eg. difference signal of two sensors or tank temperature monitoring).





**EO[®] Ermeto Original
Tubes**





General recommendations for tubes

1. Steel types, mechanical properties, conditions

Steel types, mechanical properties and conditions of EO steel tubes

Steel type	Tensile strength Rm	Yield point ReH	Ductile yield A5 (longit.)	Condition
Fine grain E235 acc. to EN 10305-4 (St. 37.4 as per DIN 1630)	340 N/mm ² min. 49,000 lb/in ²	235 N/mm ² min. 34,000 lb/in ²	25 % min.	Seamless, cold drawn under inert gas, normal annealed, abbreviation NBK, DIN 2391C, Part 2

Steel types, mechanical properties and conditions of EO stainless steel tubes

Steel type	Tensile strength Rm	Yield point (1 % proof stress)	Ductile yield A5 (longit.)	Condition
Abbreviation 1.4571 X6CrNiMoTi17122	500 N/mm ² min. 72,500 lb/in ²	245 N/mm ² min. 35,500 lb/in ²	35 % min.	Seamless, cold drawn free of scale, heat treated in accordance with DIN 17458 tab. 6
Abbreviation 1.4541 X6CrNiTi1810	500 N/mm ² min. 72,500 lb/in ²	235 N/mm ² min. 35,500 lb/in ²	35 % min.	

2. Tests and certifications

All tubes are subjected to a non-destructive leak test and marked accordingly as proof. This marking replaces a works certificate DIN 50 049-2.2. Test class 1 DIN 17458 Table 7 applies for tubes made of 1.4571 and 1.4541.

3. Recommended bend radius

A bend radius of 3x the external tube diameter is recommended for cold bending of tubes with tube benders or by hand.

4. Welding suitability and weldability

Tubes of E235 are weldable according to usual techniques. Types made of 1.4571 and 1.4541 (stainless) are suitable for arc welding. The welding filler should be selected in accordance with DIN 8556 part 1 taking into account the type of application and the welding technique.

5. Approximate calculation of the flow resistance in straight tubelines

The flow resistance and thus the tubeline efficiency is influenced by the tube inside diameter, the volume flow (measured or calculated) and the properties of the medium. Laminar flow should be considered in order to keep losses in the system down to a minimum. The transition from laminar to turbulent flow, which brings an increase in the flow resistance is generally defined by the Reynolds number Re 2320. Since the transition cannot be pinpointed exactly, the transition range can only be determined by measuring. If, for simplified calculation, transition at Re 2320 and a "technically smooth" tube inner surface are assumed, the limit speeds $w_{crit.}$ and the laminar to turbulent flow volume flow $\dot{v}_{crit.}$ when transition takes place, can be estimated according to the following formulas:

$$w_{crit.} = \frac{2.32 \cdot v}{d_i} \quad [\text{m} / \text{s}]$$

$$\dot{v}_{crit.} = 0.109 \cdot d_i \cdot v \quad [\text{l} / \text{min}]$$

$$d_i = \text{tube bore } \varnothing \text{ in mm}$$

$$v = \text{kinematic viscosity in mm}^2 / \text{s.}$$

For approximate calculation of the pressure drop in bar/1 m tube length, the following formulas can be used:

1. Laminar range:

$$\rho_v = \frac{0.32 \cdot w \cdot v \cdot \rho}{d_i^2 \cdot 10^3} = \frac{6.79 \cdot \dot{v} \cdot v \cdot \rho}{d_i^4 \cdot 10^3} \quad [\text{bar} / 1 \text{ m}]$$

2. Turbulent range:

$$\rho_v = \frac{0.281 \cdot w^{1.75} \cdot v^{0.25} \cdot \rho}{d_i^{1.25} \cdot 10^3}$$

$$= \frac{59 \cdot \dot{v}^{1.75} \cdot v^{0.25} \cdot \rho}{d_i^{4.75} \cdot 10^3} \quad [\text{bar} / 1 \text{ m}]$$

w = flow speed in m/s; v = kinetic viscosity in mm²/s; \dot{v} = volume flow in l/min.; ρ = density of the medium in kg/m³; d_i = pipe internal diameter in mm.

Detailed calculations of the flow resistance require an exact knowledge of the tubeline system and the operating conditions. Refer to the relevant literature for other methods of calculations.

Seamless EO steel tubes Material St. 37.4

Tolerances DIN 2391, part 1

Order Code		Chromium ⁶ -free	Tube O.D. (mm)	Tolerance	Wall thickness (mm)	Tube I.D. (mm)	Design pressure bar		Burst pressure bar	Weight kg/m
Phosphated and oiled	Zinc plated yellow						DIN 2413 I Static	DIN 2413 III Dynamic		
R04X0.5	R04X0.5VZ		4	±0.08	0.50	3.0	313	273	1160	0.047
	R04X0.75VZ		4		0.75	2.5	409	391	1820	0.063
R04X1	R04X1VZ		4	±0.08	1.00	2.0	522	500	2700	0.074
	R05X1VZ		R04X1CF		5	1.00	3.0	432	416	2120
R06X1 R06X1.5	R06X0.75VZ	R06X1CF	6	±0.08	0.75	4.5	333	288	1150	0.103
	R06X1VZ		6		1.00	4.0	389	372	1650	0.123
	R06X1.5VZ		6		1.50	3.0	549	526	2550	0.166
	R06X2VZ		6		2.00	2.0	692	662	>3500	0.197
	R06X2.25VZ		6		2.25	1.5	757	725	>3500	0.208
R08X1 R08X1.5 R08X2	R08X1VZ	R08X1CF R08X1.5CF	8	±0.08	1.00	6.0	333	288	1175	0.222
	R08X1.5VZ		8		1.50	5.0	431	412	1925	0.240
	R08X2VZ		8		2.00	4.0	549	526	2500	0.296
	R08X2.5VZ		8		2.50	3.0	658	630	2650	0.339
R10X1 R10X1.5 R10X2	R10X1VZ	R10X1CF R10X1.5CF	10	±0.08	1.00	8.0	282	248	900	0.222
	R10X1.5VZ		10		1.50	7.0	373	357	1450	0.314
	R10X2VZ		10		2.00	6.0	478	458	2025	0.395
	R10X2.5VZ		10		2.50	5.0	576	551	2675	0.462
	R10X3VZ		10		3.00	4.0	666	638	>3500	0.518
R12X1 R12X1.5 R12X2	R12X1VZ	R12X1CF R12X1.5CF R12X2CF	12	±0.08	1.00	10.0	235	209	750	0.271
	R12X1.5VZ		12		1.50	9.0	353	303	1150	0.388
	R12X2VZ		12		2.00	8.0	409	391	1600	0.493
	R12X2.5VZ		12		2.50	7.0	495	474	2025	0.586
	R12X3VZ		12		3.00	6.0	576	551	2600	0.666
	R12X3.5VZ		12		3.50	5.0	651	624		0.734
R14X2 R14X3	R14X1.5VZ		14	±0.08	1.50	11.0	302	264	975	0.462
	R14X2VZ		14		2.00	10.0	357	342	1325	0.592
	R14X2.5VZ		14		2.50	9.0	434	415	1650	0.709
	R14X3VZ		14		3.00	8.0	507	485	2200	0.814
			14		3.50	7.0	576	551	2625	0.906
R15X1 R15X1.5 R15X2 R15X3	R15X1VZ	R15X1.5CF	15	±0.08	1.00	13.0	188	170	575	0.345
	R15X1.5VZ		15		1.50	12.0	282	248	950	0.499
	R15X2VZ		15		2.00	11.0	336	321	1275	0.641
	R15X3		15		3.00	9.0	478	458	2000	0.888
R16X1.5 R16X2 R16X2.5 R16X3	R16X1.5VZ	R16X2CF	16	±0.08	1.50	13.0	264	233	850	0.536
	R16X2VZ		16		2.00	12.0	353	303	1175	0.691
	R16X2.5VZ		16		2.50	11.0	386	370	1500	0.832
	R16X3VZ		16		3.00	10.0	452	433	1850	0.962
R18X1 R18X1.5 R18X2 R18X2.5	R18X1VZ	R18X1.5CF	18	±0.08	1.00	16.0	157	143	450	0.419
	R18X1.5VZ		18		1.50	15.0	235	209	700	0.610
	R18X2VZ		18		2.00	14.0	313	273	975	0.789
	R18X2.5VZ		18		2.50	13.0	348	333	1300	0.956
	R18X3VZ		18		3.00	12.0	409	391	1575	1.111

Surface finish:

- Phosphated and oiled:
- Tubes with I.D. 1.5–5 mm: outside and inside oiled.
- Tubes from 6 mm I.D.: outside and inside phosphated and oiled.

- Zinc plated yellow:
These dimensions are externally zinc plated (coating 8–12 µm), inside oiled.
- Chromium⁶-free:
These dimensions are externally thick coat passivated (thickness of coat 8–12 µm), inside oiled.

Calculation pressures:

Calculation pressures given are according to DIN 2413 part I for **static stress**

$$P = \frac{20 \cdot K \cdot s \cdot c}{S \cdot d_a} \text{ (bar)}$$

Material characteristic value $K = 235 \text{ N/mm}^2$ and DIN 2413 part III for **dynamic stress**

$$P = \frac{20 \cdot K \cdot s \cdot c}{S \cdot (d_a + s \cdot c)} \text{ (bar)}$$

Material characteristic value $K = 226 \text{ N/mm}^2$ (permanent fatigue strength)

Safety correction value $S = 1.5$ for static and dynamic stress.
Factor c for consideration of wall thickness divergence **for static and dynamic stress** = 0.8 for tube O.D. 4 and 5; 0.85 for tube o.d. 6 and 8; 0.9 for larger tube O.D.

Seamless EO steel tubes (Continued) Material St. 37.4

Tolerances DIN 2391, part 1

Order Code		Chromium ⁶ -free	Tube O.D. (mm)	Tolerance	Wall thickness (mm)	Tube I.D. (mm)	Design pressure bar		Burst pressure bar	Weight kg/m
Phosphated and oiled	Zinc plated yellow						DIN 2413 I Static	DIN 2413 III Dynamic		
R20X2 R20X2.5 R20X3 R20X3.5	R20X1.4VZ	R20X2CF	20	±0.08	1.50	17	212	190	675	0.684
	R20X2VZ		20		2.00	16	282	248	900	0.888
	R20X2.5VZ		20		2.50	15	353	303	1100	1.079
	R20X3VZ		20		3.00	14	373	357	1400	1.258
	R20X3.5VZ		20		3.50	13	426	408	1650	1.424
	R20X4VZ		20		12	478	458	2000	1.578	
R22X1.5 R22X2 R22X2.5	R22X1.5VZ	R22X2CF	22	±0.08	1.50	19	192	173	550	0.758
	R22X2VZ		22		2.00	18	256	227	775	0.986
	R22X2.5VZ		22		2.50	17	320	278	1025	1.202
	R22X3VZ		22		3.00	16	343	328	1175	1.406
R25X2 R25X2.5 R25X3 R25X4 R25X4.5	R25X2VZ	R25X3CF	25	±0.08	2.00	21	226	201	725	1.134
	R25X2.5VZ		25		2.50	20	282	248	850	1.387
	R25X3VZ		25		3.00	19	338	292	1025	1.628
	R25X4VZ		25		4.00	17	394	378	1500	2.072
	R25X4.5VZ		25		4.50	16	437	418	1625	2.275
R28X1.5 R28X2 R28X2.5 R28X3	R28X1.5VZ	R28X2CF	28	±0.08	1.50	25	151	138	425	0.980
	R28X2VZ		28		2.00	24	201	181	600	1.282
	R28X2.5VZ		28		2.50	23	252	223	750	1.572
	R28X3VZ		28		3.00	22	302	264	900	1.850
R30X2.5 R30X3 R30X4 R30X5	R30X2VZ	R30X3CF	30	±0.08	2.00	26	188	170	575	1.381
	R20X2.5VZ		30		2.50	25	235	209	725	1.695
	R30X3VZ		30		3.00	24	282	248	850	1.998
	R30X4VZ		30		4.00	22	336	321	1175	2.565
	R30X5VZ		30		5.00	20	409	391	1600	3.083
R35X2 R35X2.5 R35X3	R35X2VZ	R35X2CF	35	±0.15	2.00	31	161	147	450	1.628
	R35X2.5VZ	R35X3CF	35		2.50	30	201	181	600	2.004
	R35X3VZ		35		3.00	29	242	215	700	2.367
	R35X4VZ		35		4.00	27	322	280	960	3.058
R38X2.5 R38X3 R38X4 R38X5	R38X2.5VZ	R38X4CF	38	±0.15	2.50	33	186	168	550	2.189
	R38X3VZ		38		3.00	32	223	199	675	2.589
	R38X4VZ		38		4.00	30	297	260	900	3.354
	R38X5VZ		38		5.00	28	332	318	1150	4.069
	R38X6VZ		38		6.00	26	390	373		4.735
	R38X7VZ		38		24	446	427	1700	5.352	
R42X2 R42X3 R42X4	R42X2VZ	R42X2CF	42	±0.2	2.00	38	134	123	375	1.973
	R42X3VZ	R42X3CF	42		3.00	36	201	181	575	2.885
	R42X4VZ		42		4.00	34	269	237	850	3.749
R50X6			50	±0.2	6.00	38	338	292		6.511
R65X8			65	±0.3	8.00	49	347	299		11.246

Remarks:

Corrosion – additional allowances are not considered for the calculation of pressures. Tube with a diameter ratio of

$\frac{d_a}{d_{i_{max}}} \geq 1.35$ are calculated for static stress in

accordance with DIN 2413 coverage III, but with $K = 235 \text{ N/mm}^2$.

When a specific factor of safety is required, calculations should be based upon the burst pressures shown in the above tables.

Temperature range: –40° up to 120°C without pressure reductions.

For increased temperatures:

control calculation according to DIN 2413 II required (static application above 120 °C).

$$P = \frac{20 \cdot K \cdot s \cdot c}{S (d_a - s \cdot c)}$$

Material strength K for increased temperatures:

Temperature in °C	K (N/mm ²)
up to 200	185
up to 250	165

Seamless EO stainless steel tubes Material-No.: 1.4571/1.4541

Tolerances DIN 2391, part 1

Order Code		Tube O.D. (mm)	Tolerance	Wall thickness (mm)	Tube I.D. (mm)	1.4571 Design pressure bar DIN 2413-I Static	1.4541 Design pressure bar DIN 2413-I Static	1.4571 burst pressure bar	Weight kg/m
1.4571	1.4541								
R04X171		4	±0.08	1.0	2	600	539		0.075
R06X171	R06X141	6	±0.08	1.0	4	426	383	1850	0.125
R06X1.571		6	±0.08	1.5	3	600	539	2900	0.169
R08X171	R08X141	8	±0.08	1.0	6	368	297	1300	0.175
R08X1.571		8		1.5	5	472	424	2050	0.244
R10X171	R10X141	10	±0.08	1.0	8	294	242	950	0.225
R10X1.571	R10X1.541	10		1.5	7	389	349	1750	0.319
R10X271		10		2.0	6	498	447	2400	0.401
R12X171	R12X141	12	±0.08	1.0	10	245	205	850	0.275
R12X1.571	R12X1.541	12		1.5	9	368	297	1400	0.394
R12X271		12		2.0	8	426	383	1900	0.501
R14X1.571		14	±0.08	1.5	11	315	258	1200	0.469
R14X271		14		2.0	10	420	334	1550	0.601
R14X2.571		14		2.5	9	452	406	2100	0.720
R15X171	R15X1.541	15	±0.08	1.0	13	196	166	675	0.351
R15X1.571		15		1.5	12	294	242	1100	0.507
R15X271		15		2.0	11	392	314	1400	0.651
R16X1.571	R16X241	16	±0.08	1.5	13	276	228	950	0.545
R16X271		16		2.0	12	368	297	1300	0.701
R16X2.571		16	±0.08	2.5	11	403	362	1850	0.845
R16X371		16		3.0	10	472	424	2400	0.977
R18X1.571	R18X1.541	18	±0.08	1.5	15	245	205	800	0.620
R18X271		18		2.0	14	327	267	1150	0.801
R20X271		20	±0.08	2.0	16	294	242	1050	0.901
R20X2.571		20		2.5	15	368	297	1400	1.095
R20X371		20		3.0	14	389	349	1800	1.277
R22X1.571		22	±0.08	1.5	19	200	170	650	0.770
R22X271		22		2.0	18	267	222	900	1.002
R25X2.571		25	±0.08	2.5	20	294	242	1050	1.408
R25X371		25		3.0	19	353	286	1275	1.653
R28X1.571		28	±0.08	1.5	25	158	135	550	0.995
R28X271		28		2.0	24	210	177	700	1.302
R30X2.571		30	±0.08	2.5	25	245	205	850	1.722
R30X371		30	±0.08	3.0	24	294	242	1150	2.028
R30X471		30		4.0	22	392	314	1500	2.605
R35X271		35	±0.15	2.0	31	168	143	550	1.653
R38X471		38	±0.15	4.0	30	309	254	1150	3.405
R42X271		42	±0.2	2.0	38	140	121	475	2.003
R42X371		42		3.0	36	210	177	750	2.930

Seamless EO stainless steel tubes (continued) Material-No.: 1.4571/1.4541

Calculation pressure:

Calculation pressures given are according to DIN 2413 part I for **static stress**

$$P = \frac{20 \cdot K \cdot s \cdot c}{S \cdot d_a} \text{ (bar)}$$

Material characteristic value $K=245 \text{ N/mm}^2$ (1.4571),

$K=235 \text{ N/mm}^2$ (1.4541) (1% proof stress)

Safety factor $S = 1.5$

Factor c for consideration of wall thickness divergence: 0.9

For range of application for which a certain safety value compared to burst pressure is demanded for tubes of 1.4571 grade stainless steel, the measured burst pressures are contained in tube-tables. Burst pressure values for tubes of 1.4541 grade stainless steel are not available. Calculation pressures according to DIN 2413 part III for **dynamic stress** are not listed, because in DIN 17458 the permanent fatigue stress is not listed. Until standards will be available for gauge localization of permanent fatigue strength we recommend for calculations to use DIN 2413 part III with the following characteristic values: permanent fatigue strength $K=190 \text{ N/mm}^2$ for tubes of 1.4571 and 1.4541; $S=1.5$; $C=0.9$.

Remarks:

Corrosion: additional allowances are not considered for the calculation of pressures.

Tubes with a diameter proportion $d_a/d_i \geq 1.35$ are calculated according to DIN 2413 part III with above characteristic values.

Permissible temperature range and required pressure reductions. This is based on calculated pressures at the elevated temperatures shown, taking into consideration the recommended reduction in proof stress (DIN 17458).

Temperature	-60° up to +20° C	50°C	100°C	200°C	300°C	400°C	
Pressure	1.4571	-	5.5	11.5	21.5	29	34
reductions in %	1.4541	-	4.5	11	20	29	33

Interpolation is acceptable for intermediate temperature levels.

Seamless EO steel tubes Material C-STEEL

for hydraulic and pneumatic pressure lines.

US Norm SAE J 524, C-Steel.

Test according ASTM A 179-90 A/ASME SA 179.

Quality and leak tested.

Order Code (With Tube O.D. and wall thickness Inch)	Tube O.D. (mm)	Tolerance	Wall thickness (mm)	Design pressure bar		burst pressure bar	Weight kg/m
				DIN 2413 I Static	DIN 2413 III Dynamic		
R1/4X0.049	6.35	±0.08	1.24	553	450	-	0.157
R3/8X0.049	9.53	±0.08	1.24	368	316	-	0.254
R3/8X0.065	9.53	±0.08	1.65	489	405	-	0.321
R1/2X0.049	12.70	±0.08	1.24	276	243	-	0.352
R1/2X0.065	12.70	±0.08	1.65	367	314	-	0.450
R5/8X0.083	16.00	±0.08	2.11	374	320	-	0.716
R3/4X0.095	19.05	±0.08	2.41	357	307	-	0.990
R3/4X0.104	19.05	±0.08	2.64	391	333	-	1.069
R3/4X0.109	19.05	±0.08	2.67	410	347	-	1.112
R1X0.095	25.40	±0.08	2.41	268	236	-	1.368
R1X0.120	25.40	±0.08	3.05	338	292	-	1.680
R11/4X0.120	31.75	±0.08	3.05	271	239	-	2.157
R11/2X0.156	38.10	±0.15	3.96	293	257	-	3.336

Seamless EO tube bends 90° Material St. 37.4 and 1.4571

For minimum flow loss

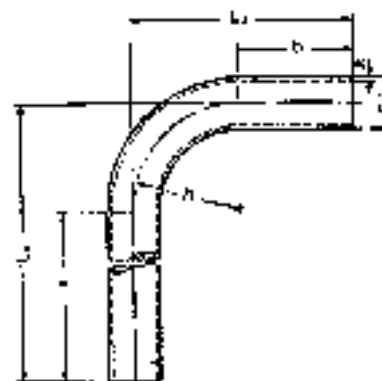

Order Code		Tube O.D. D	Tolerance ±	Wall- thickness S	Tube I.D. mm	Bending radius R	Leg length		Length		Weight kg/piece
St.37.4	1.4571						a	b	L ₁	L ₂	
RB16X2VZ	RB16X271	16	0.08	2.0	12	30	200	40	230	70	0.198
RB18X1.5VZ	RB18X1.571	18	0.08	1.5	15	36	200	35	236	71	0.178
RB20X2VZ	RB20X2.571	20	0.08	2.0	16	36	200	45	236	81	0.268
RB20X2.5VZ		20	0.08	2.5	15	36	200	45	236	81	0.326
RB22X1.5VZ	RB22X271	22	0.08	1.5	19	38	200	40	238	78	0.227
RB22X2VZ		22	0.08	2.0	18	38	200	40	238	78	0.296
RB25X2VZ	RB25X2.571	25	0.08	2.0	21	44	200	50	244	94	0.362
RB25X2.5VZ		25	0.08	2.5	20	44	200	50	244	94	0.442
RB25X3VZ		25	0.08	3.0	19	44	200	50	244	94	0.519
RB28X1.5VZ	RB28X271	28	0.08	1.5	25	48	200	50	248	98	0.319
RB28X2VZ		28	0.08	2.0	24	48	200	50	248	98	0.417
RB28X3VZ		28	0.08	3.0	22	48	200	50	248	98	0.601
RB30X2.5VZ	RB30X371	30	0.08	2.5	25	50	200	60	250	110	0.575
RB30X3VZ		30	0.08	3.0	24	50	200	60	250	110	0.677
RB30X4VZ		30	0.08	4.0	22	50	200	60	250	110	0.869
RB35X2VZ	RB35X271	35	0.15	2.0	31	60	200	65	260	125	0.586
RB35X3VZ		35	0.15	3.0	29	60	200	65	260	125	0.852
RB38X2.5VZ	RB38X471	38	0.15	2.5	33	65	200	75	265	140	0.827
RB38X3VZ		38	0.15	3.0	32	65	200	75	265	140	0.979
RB38X4VZ		38	0.15	4.0	30	65	200	75	265	140	1.268
RB38X5VZ		38	0.15	5.0	28	65	200	75	265	140	1.538
RB42X2VZ	RB42X271	42	0.20	2.0	38	80	200	85	280	165	0.809
RB42X3VZ		42	0.20	3.0	36	80	200	85	280	165	1.183
RB50X6*		50	0.20	6.0	38	180	150	150	330	330	3.496
RB65X8*		65	0.30	8.0	49	180	160	160	330	330	6.294

Tolerances for leg length a, b = ±2.5 mm

For tube bends, contrary to straight tubes of the same wall thickness there is a higher stress at the inside of the bend and a reduction of the fatigue strength, because of the out-of-round of tube. Details see DIN 2413 section 4.7.

Tube bends material St. 37.4 are zink plated yellow.

*phosphated and oiled



EO[®] Ermeto Original ***Tube clamps***



Visual index

Technical data	S3
Material properties	S4
Assembly instruction	S5/6
Light series (DIN 3015, part 1)	S6
Heavy series (DIN 3015, part 2)	S6
Double series (DIN 3015, part 3)	S6
Recommended clamp pitch	S7
Pipe bend assembly	S7

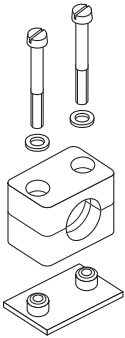
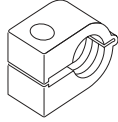
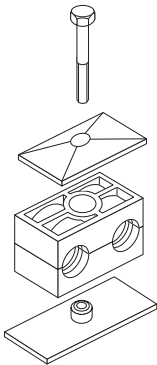
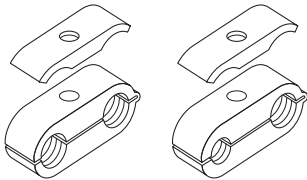
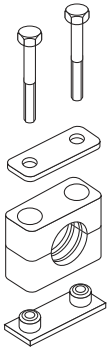
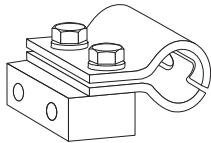
<p>Tube clamps series A</p>	 <p>p. S8–S17</p>	<p>Tube clamps series O</p>	 <p>p. S35</p>
<p>Tube clamps series B</p>	 <p>p. S18–S22</p>	<p>Double-Tube clamps series O</p>	 <p>p. S36</p>
<p>Tube clamps series C</p>	 <p>p. S23–S33</p>	<p>Hydraulic steel-clamps</p>	 <p>p. S37</p>

Tube clamps

DIN 3015

Programme:

Tube clamps series A (according to DIN 3015 Part 1)

Available in seven standard sizes for normal mechanical requirements.

- Outer tube diameter for the metric series 6 to 57 mm
- Outer tube diameter for the inch-size series R $\frac{1}{8}$ " to R $1\frac{1}{2}$ "
- Outer tube diameter for the imperial size series $\frac{1}{4}$ " to $2\frac{1}{2}$ "

The clamp body is available in a round/closed version.

Welding plates, rail-supports, cover plates and construction types.

Tube clamps series B (according to DIN 3015 Part 3)

Available as a twin tube clamp in five standard sizes for normal mechanical requirements.

Outer tube diameter 6 to 42 mm.

The clamp body is available in a square/open design.

Welding plates, rail-supports, cover plates and construction types.

Clamp halves with different diameters are only possible when used together.

Tube clamps series C (according to DIN 3015 Part 2)

Specially designed for high mechanical requirements, and available in eight standard sizes.

- Outer tube diameter 6 to 220 mm.

The clamp body is available in a square/closed design.

Welding plates, rail-supports, cover plates and construction types.

Design:

According to DIN 3015:

Both upper and lower clamp-halves are identical.

Webs inside the bore of the clamps provide an impact and vibration deadening effect, and absorb the forces towards the direction of the tube axis.

When using hoses and cables, we recommend the use of clamp halves with a smooth bore.

Clamp material:

Polypropylene	–30°C up to + 90°C	colour dark green
Polyamide	–40°C up to + 120°C	colour black
Rubber	–50°C up to + 120°C	colour black
Aluminium	up to + 300°C	

All metal parts available also in stainless steel.

Other materials upon request.

Stainless steel qualities

Stainless steel 1.4401/1.4571 (AISI 316/316 TI), resistant against rust and acid.

Accessories material:

Steel. Screws as well as cover plates of series A and B are galvanized.

Rail-supports are also available with zinc plated surface.

Resistance to stress:

The remarkable features of **Tube Clamps** are their considerable re-set capability, high tensile strength, as well as their very high output strength and excellent resistance to cold. The choice of design and clamp material depends on the specific demands of the mechanical and thermal requirements.

Order code:

The order code for clamp halves as well as the reference No. for complete tube clamps incorporates the serial indication, material description and interior surface.

Example of description:

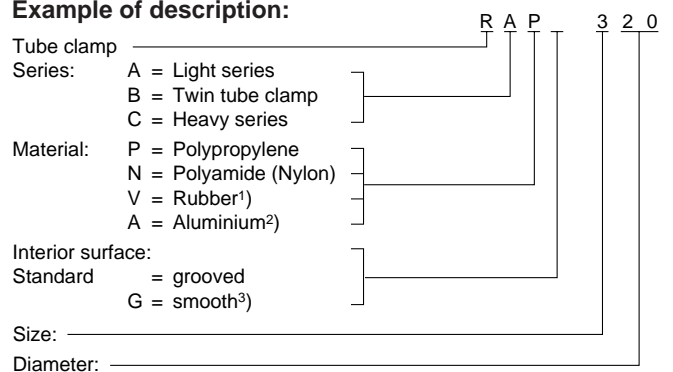

¹⁾ Rubber only available for series A and B, inside smooth and series C grooved design

²⁾ Aluminium only available for series A size 1 to 6 and series C size 1 to 8

³⁾ Smooth interior surface in series C only to size 4
Aluminium clamps only available in a grooved design
Inside smooth series A only size 1 to 6

Registration:

German Lloyd, Lloyd s Register of Shipping and others.

Tube clamps material properties

DIN 3015

Mechanical properties		Polypropylene (PP)	Polyamide 6 (PA 6)	Aluminium	Rubber
Density		0.906 g/cm ³	1.12–1.15g/cm ³	2.65 g/cm ³	0.98 g/cm ³
Flexural deflection	DIN 53452	36 N/mm ²	130...200 N/mm ²	70 N/mm ²	–
Impact resistance	DIN 53453	no break	no break	–	
Compressive strength	DIN 53454	90 N/mm ²	120 N/mm ²	HB 500...600 N/mm ²	A and B: 64° shore C: 73° shore
Modulus of elasticity	DIN 53452	1500 N/mm ²	3000 N/mm ²	70.000 N/mm ²	
Tensile strength					A and B: 6.1 N/mm ²
without breakage	DIN 53454	25–35 N/mm ²	80–90 N/mm ²	180 N/mm ²	C: 8.5 N/mm ²

Thermal properties					
Temp. resistance		–30 ... + 90° C	–40 ... + 120° C	300° C	–50 ... +120° C

Chemical properties					
Weak acids		limited resistant	limited resistant		resistant
Weak alkalis		limited resistant	limited resistant		resistant
Alcohol		resistant	resistant		resistant
Petrol		limited resistant	resistant		limited resistant
Mineral oils		resistant	resistant		resistant
Other oils		resistant	resistant		resistant

The outlined particulars are approximate values and are only shown for reference, which are not binding, and with regard to possible protection of third parties. They do not exempt you from your own examination of suitability of the products delivered by us. Therefore, these values can only be used in a limited way for guidance only.

The application of the products is carried out outside of our control and, therefore, is exclusively subject to your own area of responsibility. Any claim however would be limited for all damages to the value of the goods supplied by us and in use by you.

It goes without saying, that we guarantee the perfect quality of our products according to our general sales and delivery conditions.

Tube clamps assembly instruction

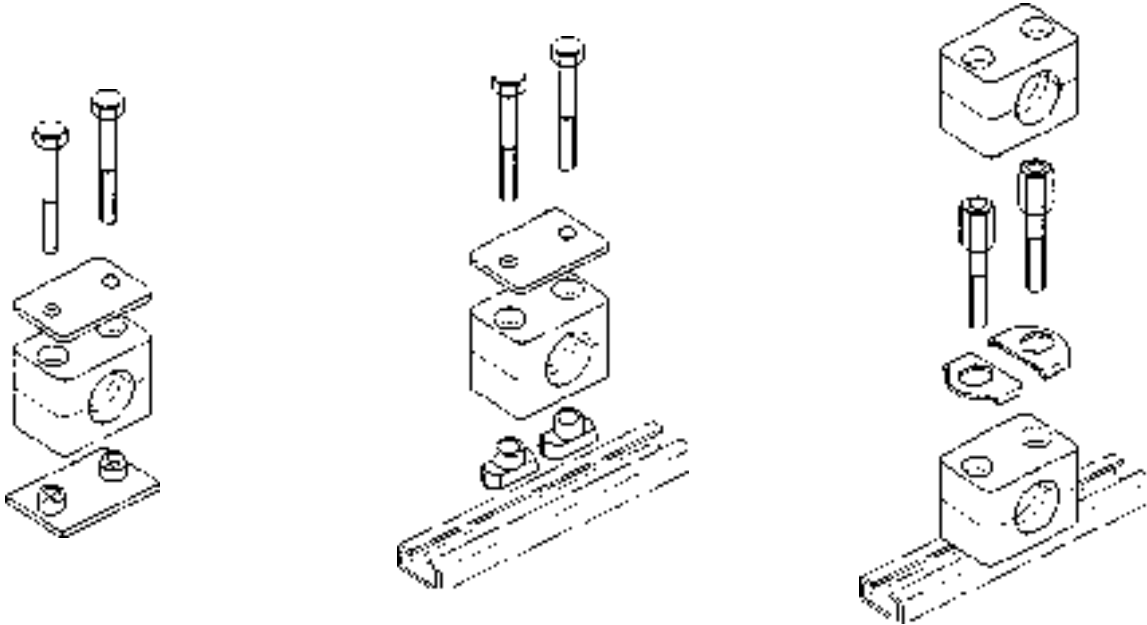

Assembly:

Assembly on to metal welding plates

Place welding plates on a base appropriate for the load. Make sure that the clamps are properly aligned. Clamp lower clamp half onto welding plate, insert tube, place upper clamp half onto lower half and fasten with the screws. Attention must be paid to the bias (after completed assembly, clamp halves may not be in contact)! Do not weld with fitted plastic clamp! Extended welding plates may be screw-fastened to the base.

Assembly on support rails

Support rails are available in four different heights and come in pieces of 1 m or 2 m length, as required. Weld on support rail or screw-fasten with fastening angle bracket. Insert support rail nuts in rail and turn until stoppage. For heavy duty construction series, nuts are simply pushed in. Clamp lower clamp half on support rail nuts, insert tube, place upper clamp half onto lower half and fasten with the screws. Before fastening the screws the clamp may still be positioned. Attention must be paid to the bias (after completed assembly, the clamp halves may not be in contact)!

Construction assembly

RSB-Clamps allow the assembly of multiple clamps of the same construction size and of different tube diameters one above the other. The construction assembly is carried out with special fixing screws that are secured against twisting by applying a locking plate. Clamp lower clamp half on welding plate or support rail respectively, insert tube, place upper clamp half on lower half and fasten with fixing screws. The fixing screw juts out from the upper clamp half. The application of a locking plate securely fastens the fixing screw and prevents twisting. Clamp on second clamp half on to the fixing screws etc.



Tube clamps
DIN 3015
Screw tightening torque and axial pipe shearing forces

The indicated screw tightening torque and axial pipe shearing forces refer to the assembly with cover plates and outside hexagon bolts according to DIN 931/933. The axial pipe shearing force (according to DIN 3015, part 10) is an average value, determined by three tests made with a steel pipe according to DIN 2448 of St. 37, for which static friction is assumed (temperature during tests: 23°C). When loading the clamp with the indicated test force (F) in axial pipe direction, the pipe must not slide in the clamp.

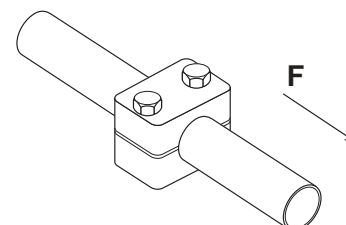
Light series (DIN 3015, part 1)

Size	Fixing screw DIN 931/933	Polypropylene		Polyamide		Aluminium	
		Screw tightening torque (Mn)	Pipe shearing force F (kN)	Screw tightening torque (Mn)	Pipe shearing force F (kN)	Screw tightening torque (Mn)	Pipe shearing force F (kN)
0	M6	8	0.6	10	0.6		
1	M6	8	1.1	10	0.7	12	4.2
2	M6	8	1.2	10	0.8	12	4.3
3	M6	8	1.4	10	1.6	12	4.8
4	M6	8	1.5	10	1.7	12	5.0
5	M6	8	1.9	10	2.0	12	7.3
6	M6	8	2.0	10	2.5	12	8.9

Heavy series (DIN 3015, part 2)

Size	Fixing screw DIN 931/933	Polypropylene		Polyamide		Aluminium	
		Screw tightening torque (Mn)	Pipe shearing force F (kN)	Screw tightening torque (Mn)	Pipe shearing force F (kN)	Screw tightening torque (Mn)	Pipe shearing force F (kN)
1	M10	12	1.6	20	4.2	30	12.1
2	M10	12	2.9	20	4.5	30	15.1
3	M10	15	3.3	25	5.1	35	15.5
4	M12	30	8.2	40	9.3	55	29.4
5	M16	45	11.0	55	15.8	120	34.8
6	M20	80	14.0	150	21.0	220	50.0
7	M24	110	28.0	200	32.0	250	70.6
8	M30	180	40.0	350	48.0	500	84.5

Double series (DIN 3015, part 3)

Size	Fixing screw DIN 931/933	Polypropylene		Polyamide	
		Screw tightening torque (Mn)	Pipe shearing force F (kN)	Screw tightening torque (Mn)	Pipe shearing force F (kN)
1	M6	5	0.9	5	0.9
2	M8	12	2.1	12	2.2
3	M8	12	1.9	12	2.0
4	M8	12	2.7	12	2.9
5	M8	8	1.7	8	2.5

Tube clamps

DIN 3015

Recommended clamp pitch

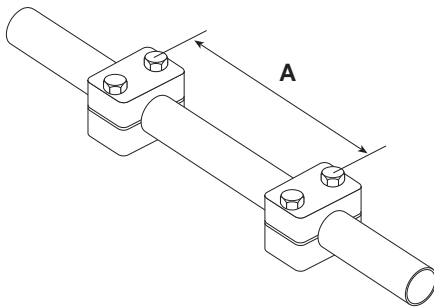

Pipe bend assembly

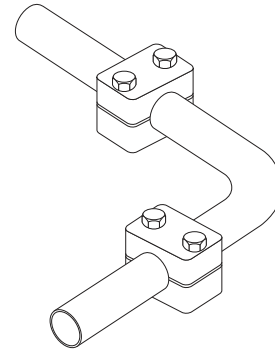

The clamp pitches corresponding to respective outside pipe diameters are standard for static loads.

Pipe bends must be fixed with pipe clamps immediately in front of and behind the bend.

Outside pipe diameter (mm)	Clamp pitch A (m)
6.0 – 12.7	1.0
12.7 – 22.0	1.2
22.0 – 32.0	1.5
32.0 – 38.0	2.0
38.0 – 57.0	2.7
57.0 – 75.0	3.0
75.0 – 76.1	3.5
76.1 – 88.9	3.7
88.9 – 102.0	4.0
102.0 – 114.0	4.5
114.0 – 168.0	5.0
168.0 – 219.0	6.0

Tube clamps series A (Light construction series) – Components

DIN 3015, part 1

Order code for clamp halves:

- Polypropylene – **RAP**
- Inside smooth – **RAPG**
- Polyamide 6 – **RAN**
- Inside smooth – **RANG**
- Rubber – **RAVG**
- Aluminium – **RAA¹⁾**

 (Please exchange as required standard abbreviation
 RAP in column for “clamp halves”)

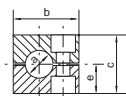

size 0



size 0

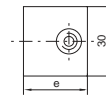

size 0



size 0

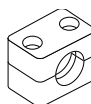

size 1-6

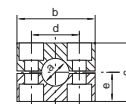

size 1-6

Width: 30 mm

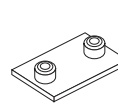

size 1-6

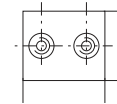

size 1-6

 Thickness:
 3 mm

clamp size	Tube O.D. mm a	Tube NB	Tube O.D.	1 part		welding plate, short	
				2 clamp halves RAP... Order code	dimensions: b c d e	APK A... Order code	dimensions: d e
0	6	G ¹ / ₈	1/4	RAP006X RAP006.4X RAP008X RAP009.5X RAP010X RAP012X	28 27 – 13.5	APKA0X	– 30
	6.4						
	8						
	9.5						
	10						
1	12	G ¹ / ₈	5/16 3/8	RAP106X RAP106.4X RAP108X RAP109.5X RAP110X RAP112X	34 27 20 13.5	APKA1X	20 36
	6						
	6.4						
	8						
	9.5						
2	10	G ¹ / ₄	1/2	RAP212.7X RAP213.5X RAP214X RAP215X RAP216X RAP217.2X RAP218X	40 33 26 16.5	APKA2X	26 42
	12.7						
	13.5						
	14	G ³ / ₈	5/8				
	15						
	16						
3	17.2	G ¹ / ₂	3/4	RAP319X RAP320X RAP321.3X RAP322X RAP323X RAP325X	48 35 33 17.5	APKA3X	33 50
	18						
	19						
	20						
	21.3						
4	22	G ³ / ₄	1	RAP426.9X RAP428X RAP430X	57 42 40 21	APKA4X	40 59
	23						
	25						
	26.9						
5	28	G1	1 1/4	RAP532X RAP533.7X RAP535X RAP538X RAP540X RAP542X	70 58 52 29	APKA5X	52 72
	30						
	32						
	33.7	G1 1/4	1 1/2				
	35						
6	38	G1 1/2	1 3/4	RAP644.5X RAP645X RAP648X RAP650X RAP650.8X RAP652X RAP655X RAP657X	86 66 66 33	APKA6X	66 88
	40						
	42						
	44.5						
	45						
	48						
50							
50.8							
52							
55							
57							
			2 1/4				

When assembling solid rubber clamps, covering plates, hexagon screws and locking washers must be used. All metal parts available in stainless steel.

¹⁾ Aluminium only sizes 1 to 6.

Tube clamps series A (Light construction series) – Components

DIN 3015, part 1

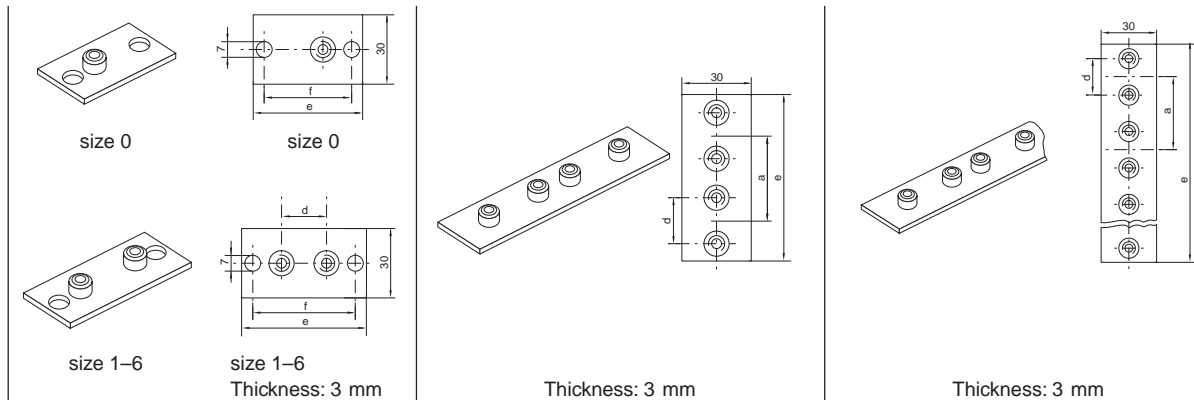

clamp size	weld/screw plate, long			twin welding plate			multiple weld plate					
	APL A... Order code	dimensions: d e f			APD A... Order code	dimensions: d a e			APR A... Order code	dimensions: d a e		
0	APLA0X	–	58	44	APDA0X	–	30	61	APRA0X (10 clamps)	–	30	298
1	APLA1X	20	64	50	APDA1X	20	35	69	APRA1X (10 clamps)	20	35	349
2	APLA2X	26	70	56	APDA2X	26	43	86	APRA2X (10 clamps)	26	43	427
3	APLA3X	33	78	64	APDA3X	33	52	104	APRA3X (10 clamps)	33	52	516
4	APLA4X	40	87	73	APDA4X	40	60	117	APRA4X (5 clamps)	40	60	297
5	APLA5X	52	100	86	APDA5X	52	75	145	APRA5X (5 clamps)	52	75	370
6	APLA6X	66	116	100	APDA6X	66	90	176	APRA6X (5 clamps)	66	90	446

Metal parts also available in stainless steel.



Tube clamps series A (Light construction series) – Components

DIN 3015, part 1

	<p>size 0</p> <p>size 1-6 Thickness: 3mm</p>		<p>1 or 2 mtr</p>						
clamp size	weld plate, angled		mounting rail		rail nut				
	APW A... Order code	dimensions: d e	TS...A/B Order code	dimensions: h	TM...A/B1 Order code	dimensions: a b c m			
0	APWA0X	14 30	TS11A/B1X TS11A/B2X TS14A/B1X TS14A/B2X TS30A/B1X TS30A/B2X	TS11: 11 TS14: 14 TS30: 30	TMA/TMB1VERZX	25.4 10.4 12 M6			
1	APWA1X	20 36							
2	APWA2X	26 42							
3	APWA3X	33 50							
4	APWA4X	40 59							
5	APWA5X	52 72							
6	APWA6X	66 88							

Metal parts also available in stainless steel.

Tube clamps series A (Light construction series) – Components

DIN 3015, part 1

clamp size	cover plate		slot head		hexagon head		socket head	
	DP A... Order code	dimensions: b d	SL A... Order code	dimensions: d x L	SSL A... Order code	dimensions: d x L	IS A... Order code	dimensions: d x L
0	DPA0X	– –	SLA0X	M 6 x 20	SSL10X	M 6 x 30	ISA0X	M 6 x 20
1	DPA1X	34 20	SLA1X	M 6 x 20	SSL10X	M 6 x 30	ISA1X	M 6 x 20
2	DPA2X	40 26	SLA2X	M 6 x 25	SSLA2/SSB1X	M 6 x 35	ISA2X	M 6 x 25
3	DPA3X	48 33	SLA3X	M 6 x 30	SSLA3X	M 6 x 40	ISA3X	M 6 x 30
4	DPA4X	57 40	SLA4X	M 6 x 35	SSLA4X	M 6 x 45	ISA4X	M 6 x 35
5	DPA5X	70 52	SLA5X	M 6 x 50	SSLA5X	M 6 x 60	ISA5X	M 6 x 50
6	DPA6X	86 66	SLA6X	M 6 x 60	SSLA6X	M 6 x 70	ISA6X	M 6 x 60

All metal parts available in stainless steel.

Tube clamps series A (Light construction series) – Components

DIN 3015, part 1

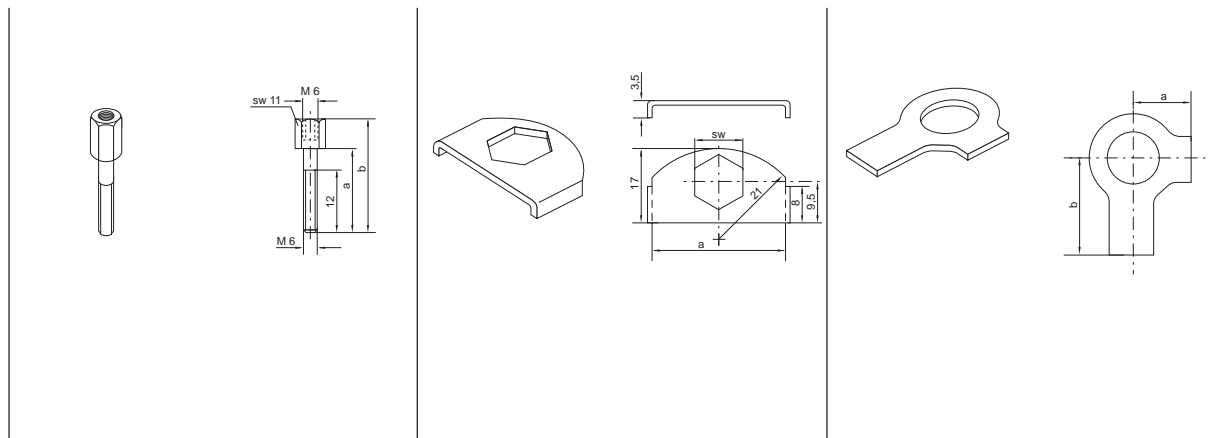

clamp size	stacking ¹⁾		locking plate ¹⁾		locking washer ²⁾	
	AS A... Order code	dimensions: a b	SB A Order code	dimensions: a SW	US A Order code	dimensions: a b
0	ASA0X (AS B1X)	20 34	SBAX	30 11	USA/USB1X	9 18
1	ASA0X (ASB1X)	20 34				
2	ASA2X	25 39				
3	ASA3X	30 44				
4	ASA4X	35 49				
5	ASA5X	50 64				
6	ASA6X	60 74				

¹⁾ The use of stacking bolts necessitates the use of locking plates in the construction assembly.

²⁾ When assembling solid rubber clamps, cover plates, hexagon screws and locking washers must be used. Metal parts also available in stainless steel.

Tube clamps series A (Light construction series) – Complete range

Polypropylene – **RAP**
 Inside smooth – **RAPG**
 Polyamide 6 – **RAN**
 Inside smooth – **RANG**
 Rubber – **RAVG***
 Aluminium – **RAA**

(As required please exchange standard abbreviation RAP in column for "Order code")

2 clamp halves, weld plate **short**, slot head bolts and bushes

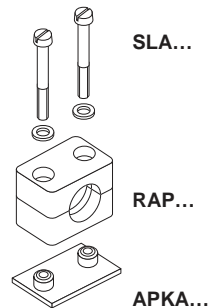

2 clamp halves, weld plate **short**, socket head bolts and bushes

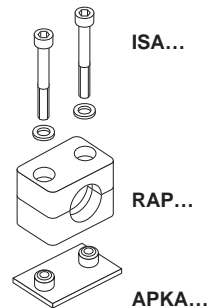

2 clamp halves, weld plate **short**, cover plate hex. head bolts

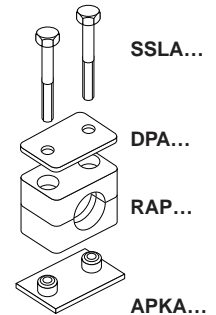

clamp size	Tube O.D. mm	Tube NB	Tube O.D.	Order code	Order code	Order code
0 ¹⁾	6	G ¹ / ₈	1/4 5/16 3/8	RAP1-006	RAP2-006	RAP3-006
	6.4			RAP1-006.4	RAP2-006.4	RAP3-006.4
	8			RAP1-008	RAP2-008	RAP3-008
	9.5			RAP1-009.5	RAP2-009.5	RAP3-009.5
	10			RAP1-010	RAP2-010	RAP3-010
	12			RAP1-012	RAP2-012	RAP3-012
1	6	G ¹ / ₈	1/4 5/16 3/8	RAP1-106	RAP2-106	RAP3-106
	6.4			RAP1-106.4	RAP2-106.4	RAP3-106.4
	8			RAP1-108	RAP2-108	RAP3-108
	9.5			RAP1-109.5	RAP2-109.5	RAP3-109.5
	10			RAP1-110	RAP2-110	RAP3-110
	12			RAP1-112	RAP2-112	RAP3-112
2	12.7	G ¹ / ₄	1/2	RAP1-212.7	RAP2-212.7	RAP3-212.7
	13.5			RAP1-213.5	RAP2-213.5	RAP3-213.5
	14			RAP1-214	RAP2-214	RAP3-214
	15	G ³ / ₈	5/8	RAP1-215	RAP2-215	RAP3-215
	16			RAP1-216	RAP2-216	RAP3-216
	17.2			RAP1-217.2	RAP2-217.2	RAP3-217.2
18	RAP1-218	RAP2-218	RAP3-218			
3	19	G ¹ / ₂	3/4	RAP1-319	RAP2-319	RAP3-319
	20			RAP1-320	RAP2-320	RAP3-320
	21.3			RAP1-321.3	RAP2-321.3	RAP3-321.3
	22			RAP1-322	RAP2-322	RAP3-322
	23			RAP1-323	RAP2-323	RAP3-323
	25			RAP1-325	RAP2-325	RAP3-325
4	26.9	G ³ / ₄	1	RAP1-426.9	RAP2-426.9	RAP3-426.9
	28			RAP1-428	RAP2-428	RAP3-428
	30			RAP1-430	RAP2-430	RAP3-430
5	32	G1	1 1/4	RAP1-532	RAP2-532	RAP3-532
	33.7			RAP1-533.7	RAP2-533.7	RAP3-533.7
	35			RAP1-535	RAP2-535	RAP3-535
	38	G1 1/4	1 1/2	RAP1-538	RAP2-538	RAP3-538
	40			RAP1-540	RAP2-540	RAP3-540
	42			RAP1-542	RAP2-542	RAP3-542
6	44.5	G1 1/2	1 3/4	RAP1-644.5	RAP2-644.5	RAP3-644.5
	45			RAP1-645	RAP2-645	RAP3-645
	48			RAP1-648	RAP2-648	RAP3-648
	50			RAP1-650	RAP2-650	RAP3-650
	50.8	2	2	RAP1-650.8	RAP2-650.8	RAP3-650.8
	52			RAP1-652	RAP2-652	RAP3-652
	55			RAP1-655	RAP2-655	RAP3-655
	57			RAP1-657	RAP2-657	RAP3-657
			2 1/4			

Delivery in unassembled individual components.

¹⁾ Contrary to the illustration size 0 clamps are secured by only one screw.

* Only with cover plate, hexagon screws and locking washers.

Tube clamps series A (Light construction series) – Complete range

Polypropylene – **RAP**
 Inside smooth – **RAPG**
 Polyamide 6 – **RAN**
 Inside smooth – **RANG**
 Rubber – **RAVG***
 Aluminium – **RAA**

(As required please exchange standard abbreviation RAP in column for "Order code")

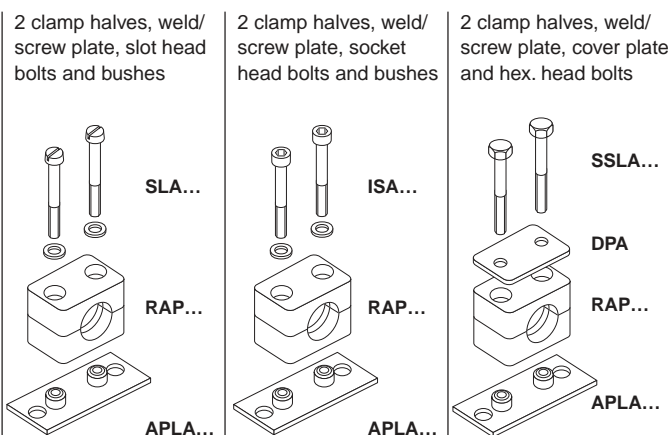

clamp size	Tube O.D. mm	Tube NB	Tube O.D.	Order code	Order code	Order code
0 ¹⁾	6	G ¹ / ₈	¹ / ₄	RAP4-006	RAP5-006	RAP6-006
	6.4			RAP4-006.4	RAP5-006.4	RAP6-006.4
	8			RAP4-008	RAP5-008	RAP6-008
	9.5			RAP4-009.5	RAP5-009.5	RAP6-009.5
	10			RAP4-010	RAP5-010	RAP6-010
	12			RAP4-012	RAP5-012	RAP6-012
1	6	G ¹ / ₈	¹ / ₄	RAP4-106	RAP5-106	RAP6-106
	6.4			RAP4-106.4	RAP5-106.4	RAP6-106.4
	8			RAP4-108	RAP5-108	RAP6-108
	9.5			RAP4-109.5	RAP5-109.5	RAP6-109.5
	10			RAP4-110	RAP5-110	RAP6-110
	12			RAP4-112	RAP5-112	RAP6-112
2	12.7	G ¹ / ₄	¹ / ₂	RAP4-212.7	RAP5-212.7	RAP6-212.7
	13.5			RAP4-213.5	RAP5-213.5	RAP6-213.5
	14			RAP4-214	RAP5-214	RAP6-214
	15	G ³ / ₈	⁵ / ₈	RAP4-215	RAP5-215	RAP6-215
	16			RAP4-216	RAP5-216	RAP6-216
	17.2			RAP4-217.2	RAP5-217.2	RAP6-217.2
18	RAP4-218	RAP5-218	RAP6-218			
3	19	G ¹ / ₂	³ / ₄	RAP4-319	RAP5-319	RAP6-319
	20			RAP4-320	RAP5-320	RAP6-320
	21.3			RAP4-321.3	RAP5-321.3	RAP6-321.3
	22	1	1	RAP4-322	RAP5-322	RAP6-322
	23			RAP4-323	RAP5-323	RAP6-323
	25			RAP4-325	RAP5-325	RAP6-325
4	26.9	G ³ / ₄		RAP4-426.9	RAP5-426.9	RAP6-426.9
	28			RAP4-428	RAP5-428	RAP6-428
	30			RAP4-430	RAP5-430	RAP6-430
5	32	G1	1 ¹ / ₄	RAP4-532	RAP5-532	RAP6-532
	33.7			RAP4-533.7	RAP5-533.7	RAP6-533.7
	35			RAP4-535	RAP5-535	RAP6-535
	38	G1 ¹ / ₄	1 ¹ / ₂	RAP4-538	RAP5-538	RAP6-538
	40			RAP4-540	RAP5-540	RAP6-540
	42			RAP4-542	RAP5-542	RAP6-542
6	44.5	G1 ¹ / ₂	1 ³ / ₄	RAP4-644.5	RAP5-644.5	RAP6-644.5
	45			RAP4-645	RAP5-645	RAP6-645
	48			RAP4-648	RAP5-648	RAP6-648
	50			RAP4-650	RAP5-650	RAP6-650
	50.8	2	2	RAP4-650.8	RAP5-650.8	RAP6-650.8
	52			RAP4-652	RAP5-652	RAP6-652
	55			RAP4-655	RAP5-655	RAP6-655
	57			RAP4-657	RAP5-657	RAP6-657
			2 ¹ / ₄			

Delivery in unassembled individual components.

¹⁾ Contrary to the illustration size 0 clamps are secured by only one screw.

* Only with cover plate, hexagon screws and locking washers.

Tube clamps series A (Light construction series) – Complete range

Polypropylene – **RAP**
 Inside smooth – **RAPG**
 Polyamide 6 – **RAN**
 Inside smooth – **RANG**
 Rubber – **RAVG***
 Aluminium – **RAA**

(As required please exchange standard abbreviation RAP in column for "Order code")

2 clamp halves, rail nuts, slot head bolts and bushes

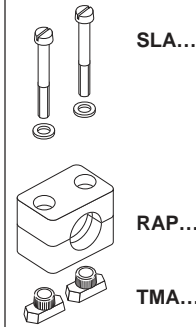

2 clamp halves, rail nuts, socket head bolts and bushes

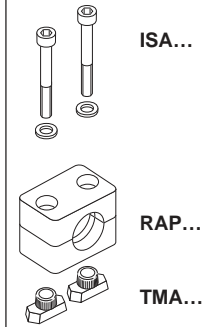

2 clamp halves, rail nuts, cover plate and hex. head bolts

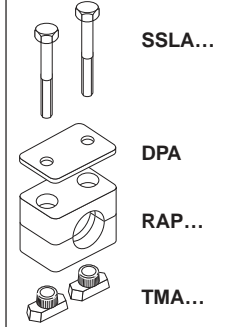

clamp size	Tube O.D. mm	Tube NB	Tube O.D.	Order code	Order code	Order code
0 ¹⁾	6	G ¹ / ₈	1/4 5/16 3/8	RAP9-006	RAP10-006	RAP12-006
	6.4			RAP9-006.4	RAP10-006.4	RAP12-006.4
	8			RAP9-008	RAP10-008	RAP12-008
	9.5			RAP9-009.5	RAP10-009.5	RAP12-009.5
	10			RAP9-010	RAP10-010	RAP12-010
	12			RAP9-012	RAP10-012	RAP12-012
1	6	G ¹ / ₈	1/4 5/16 3/8	RAP9-106	RAP10-106	RAP12-106
	6.4			RAP9-106.4	RAP10-106.4	RAP12-106.4
	8			RAP9-108	RAP10-108	RAP12-108
	9.5			RAP9-109.5	RAP10-109.5	RAP12-109.5
	10			RAP9-110	RAP10-110	RAP12-110
	12			RAP9-112	RAP10-112	RAP12-112
2	12.7	G ¹ / ₄	1/2	RAP9-212.7	RAP10-212.7	RAP12-212.7
	13.5			RAP9-213.5	RAP10-213.5	RAP12-213.5
	14			RAP9-214	RAP10-214	RAP12-214
	15	G ³ / ₈	5/8	RAP9-215	RAP10-215	RAP12-215
	16			RAP9-216	RAP10-216	RAP12-216
	17.2			RAP9-217.2	RAP10-217.2	RAP12-217.2
	18			RAP9-218	RAP10-218	RAP12-218
3	19	G ¹ / ₂	3/4	RAP9-319	RAP10-319	RAP12-319
	20			RAP9-320	RAP10-320	RAP12-320
	21.3			RAP9-321.3	RAP10-321.3	RAP12-321.3
	22			RAP9-322	RAP10-322	RAP12-322
	23			RAP9-323	RAP10-323	RAP12-323
	25		1	RAP9-325	RAP10-325	RAP12-325
4	26.9	G ³ / ₄		RAP9-426.9	RAP10-426.9	RAP12-426.9
	28			RAP9-428	RAP10-428	RAP12-428
	30			RAP9-430	RAP10-430	RAP12-430
5	32	G1	1 1/4	RAP9-532	RAP10-532	RAP12-532
	33.7			RAP9-533.7	RAP10-533.7	RAP12-533.7
	35			RAP9-535	RAP10-535	RAP12-535
	38	G1 1/4	1 1/2	RAP9-538	RAP10-538	RAP12-538
	40			RAP9-540	RAP10-540	RAP12-540
	42			RAP9-542	RAP10-542	RAP12-542
6	44.5	G1 1/2	1 3/4	RAP9-644.5	RAP10-644.5	RAP12-644.5
	45			RAP9-645	RAP10-645	RAP12-645
	48			RAP9-648	RAP10-648	RAP12-648
	50			RAP9-650	RAP10-650	RAP12-650
	50.8	2		RAP9-650.8	RAP10-650.8	RAP12-650.8
	52			RAP9-652	RAP10-652	RAP12-652
	55			RAP9-655	RAP10-655	RAP12-655
	57			RAP9-657	RAP10-657	RAP12-657
			2 1/4			

Delivery in unassembled individual components.

¹⁾ Contrary to the illustration size 0 clamps are secured by only one screw.

* Only with cover plate, hexagon screws and locking washers.

Tube clamps series A – Complete range

Polypropylene – **RAP**
 Inside smooth – **RAPG**
 Polyamide 6 – **RAN**
 Inside smooth – **RANG**
 Rubber – **RAVG***
 Aluminium – **RAA**

(As required please exchange standard abbreviation RAP in column for "Order code")

2 clamp halves, slot heads and bushes

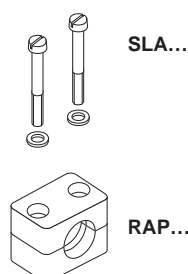

2 clamp halves, socket head bolts and bushes

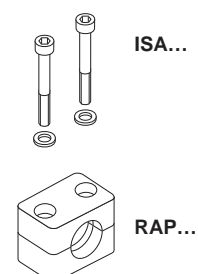

clamp size	Tube O.D. mm	Tube NB	Tube O.D.	Order code	Order code
0 ¹⁾	6	G ¹ / ₈	1/4 5/16 3/8	RAP13-006	RAP14-006
	6.4			RAP13-006.4	RAP14-006.4
	8			RAP13-008	RAP14-008
	9.5			RAP13-009.5	RAP14-009.5
	10			RAP13-010	RAP14-010
	12			RAP13-012	RAP14-012
1	6	G ¹ / ₈	1/4 5/16 3/8	RAP13-106	RAP14-106
	6.4			RAP13-106.4	RAP14-106.4
	8			RAP13-108	RAP14-108
	9.5			RAP13-109.5	RAP14-109.5
	10			RAP13-110	RAP14-110
	12			RAP13-112	RAP14-112
2	12.7	G ¹ / ₄	1/2	RAP13-212.7	RAP14-212.7
	13.5			RAP13-213.5	RAP14-213.5
	14			RAP13-214	RAP14-214
	15	G ³ / ₈	5/8	RAP13-215	RAP14-215
	16			RAP13-216	RAP14-216
	17.2			RAP13-217.2	RAP14-217.2
18	RAP13-218	RAP14-218			
3	19	G ¹ / ₂	3/4	RAP13-319	RAP14-319
	20			RAP13-320	RAP14-320
	21.3			RAP13-321.3	RAP14-321.3
	22			RAP13-322	RAP14-322
	23			RAP13-323	RAP14-323
	25			RAP13-325	RAP14-325
4	26.9	G ³ / ₄	1	RAP13-426.9	RAP14-426.9
	28			RAP13-428	RAP14-428
	30			RAP13-430	RAP14-430
5	32	G1	1 1/4	RAP13-532	RAP14-532
	33.7			RAP13-533.7	RAP14-533.7
	35			RAP13-535	RAP14-535
	38	G1 1/4	1 1/2	RAP13-538	RAP14-538
	40			RAP13-540	RAP14-540
	42			RAP13-542	RAP14-542
6	44.5	G1 1/2	1 3/4	RAP13-644.5	RAP14-644.5
	45			RAP13-645	RAP14-645
	48			RAP13-648	RAP14-648
	50			RAP13-650	RAP14-650
	50.8	2	2	RAP13-650.8	RAP14-650.8
	52			RAP13-652	RAP14-652
	55			RAP13-655	RAP14-655
	57			RAP13-657	RAP14-657
			2 1/4		

Delivery in unassembled individual components.

¹⁾ Contrary to the illustration size 0 clamps are secured by only one screw.

* Only with cover plate, hexagon screws and locking washers.

Tube clamps series A – Complete range

Polypropylene – **RAP**
 Inside smooth – **RAPG**
 Polyamide 6 – **RAN**
 Inside smooth – **RANG**
 Rubber – **RAVG***
 Aluminium – **RAA**

(As required please exchange standard abbreviation RAP in column for "Order code")

2 clamp halves, cover plate and hex. head bolts

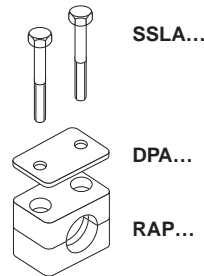

2 clamp halves, stacking bolts and locking plate

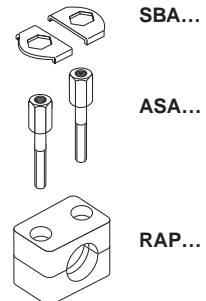

clamp size	Tube O.D. mm	Tube NB	Tube O.D.	Order code	Order code
0 ¹⁾	6	G ¹ / ₈	1/4	RAP16-006	RAP18-006
	6.4			RAP16-006.4	RAP18-006.4
	8			RAP16-008	RAP18-008
	9.5			RAP16-009.5	RAP18-009.5
	10			RAP16-010	RAP18-010
	12			RAP16-012	RAP18-012
1	6	G ¹ / ₈	1/4	RAP16-106	RAP18-106
	6.4			RAP16-106.4	RAP18-106.4
	8			RAP16-108	RAP18-108
	9.5			RAP16-109.5	RAP18-109.5
	10			RAP16-110	RAP18-110
	12			RAP16-112	RAP18-112
2	12.7	G ¹ / ₄	1/2	RAP16-212.7	RAP18-212.7
	13.5			RAP16-213.5	RAP18-213.5
	14			RAP16-214	RAP18-214
	15	G ³ / ₈	5/8	RAP16-215	RAP18-215
	16			RAP16-216	RAP18-216
	17.2			RAP16-217.2	RAP18-217.2
18			RAP16-218	RAP18-218	
3	19	G ¹ / ₂	3/4	RAP16-319	RAP18-319
	20			RAP16-320	RAP18-320
	21.3			RAP16-321.3	RAP18-321.3
	22			RAP16-322	RAP18-322
	23			RAP16-323	RAP18-323
	25			RAP16-325	RAP18-325
4	26.9	G ³ / ₄	1	RAP16-426.9	RAP18-426.9
	28			RAP16-428	RAP18-428
	30			RAP16-430	RAP18-430
5	32	G1	1 1/4	RAP16-532	RAP18-532
	33.7			RAP16-533.7	RAP18-533.7
	35			RAP16-535	RAP18-535
	38	G1 1/4	1 1/2	RAP16-538	RAP18-538
	40			RAP16-540	RAP18-540
	42			RAP16-542	RAP18-542
6	44.5	G1 1/2	1 3/4	RAP16-644.5	RAP18-644.5
	45			RAP16-645	RAP18-645
	48			RAP16-648	RAP18-648
	50			RAP16-650	RAP18-650
	50.8	2	2	RAP16-650.8	RAP18-650.8
	52			RAP16-652	RAP18-652
	55			RAP16-655	RAP18-655
	57			RAP16-657	RAP18-657
			2 1/4		

Delivery in unassembled individual components.

¹⁾ Contrary to the illustration size 0 clamps are secured by only one screw.

* Only with cover plate, hexagon screws and locking washers.

Tube clamps series B (Twin-tube clamps) – Components

DIN 3015, part 3

Order code for clamp halves:

 Polypropylene – **RBP**
 Inside smooth – **RBPG**
 Polyamide 6 – **RBN**
 Rubber – **RBVG**

(Please exchange standard abbreviation RBP in column for “clamp halves” as required.)

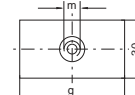
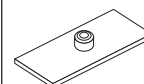
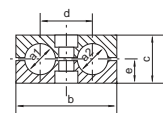
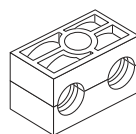

Width: 30 mm

clamp size	Tube O.D. mm	Tube NB	Tube O.D.	1 part 2 clamp halves ¹⁾					weld plate		
				RBP... Order code	dimensions: b c d e				APB... Order code	dimensions: g m	
1	6	G ^{1/8}	1/4	RBP106X RBP106.4X RBP108X RBP109.5X RBP110X RBP112X	36	27	20	13.5	APB1X	37	M 6
	6.4										
	8										
	8.5										
	10										
12											Thickness: 3 mm
2	12.7	G ^{1/4}	1/2	RBP212.7X RBP213.5X RBP214X RBP215X RBP216X RBP217.2X RBP218X	53	26	29	13	APB2X	55	M 8
	13.5										
	14										
	15	G ^{3/8}	5/8								
	16										
	17.2										
18										Thickness: 5 mm	
3	19	G ^{1/2}	3/4	RBP319X RBP320X RBP321.3X RBP322X RBP325X	67	37	36	18.5	APB3X	70	M 8
	20										
	21.3										
	22										
	25										
4	26.9	G ^{3/4}	1	RBP426.9X RBP428X RBP430X	82	42	45	21	APB4X	85	M 8
	28										
	30										
5	32	G1	1 1/4	RBP532X RBP533.7X RBP535X RBP538X RBP542X	106	54	56	27	APB5X	110	M 8
	33.7										
	35										
	38	G1 1/4	1 1/2								
	42										

Metal parts also available in stainless steel.

¹⁾ Twin-tube clamps with different outer tube diameters upon request.

Tube clamps series B (Twin-tube clamps) – Components

DIN 3015, part 3

clamp size	multiple weld plate		mounting rail		rail nut				
	APRB... Order code	dimensions: d e	TS... A/B Order code	dimensions: h	TM... Order code	dimensions: a b c m			
1	APRB1X (5 clamps)	40 196 Thickness: 3 mm	TS11A/B1X TS11A/B2X TS14A/B1X TS14A/B2X TS30A/B1X TS30A/B2X	TS11: 11 TS14: 14 TS30: 30	TMA/TMB1VERZX	25.4	10.4	12	M 6
2	APRB2X (5 clamps)	58 288 Thickness: 5 mm			TMB2X	25.4 10.4 12 M8			
3	APRB3X (5 clamps)	72 358 Thickness: 5 mm							
4	APRB4X (5 clamps)	90 446 Thickness: 5 mm							
5	APRB5X (5 clamps)	112 558 Thickness: 5 mm							

Tube clamps series B (Twin-tube clamps) – Components

DIN 3015, part 3

clamp size	cover plate		hexagonal head	
	DP B... Order code	dimensions: b d	SS B... Order code	dimensions: d x L
1	DPB1X	34 6.6	SSLA2/SSB1X	M 6 x 35
2	DPB2X	51 8.6	SSB2X	M 8 x 35
3	DPB3X	64 8.6	SSB3X	M 8 x 45
4	DPB4X	78 8.6	SSB4X	M 8 x 50
5	DPB5X	102 8.6	SSB5X	M 8 x 60

Metal parts also available in stainless steel.

Tube clamps series B (Twin-tube clamps) – Components

DIN 3015, part 3

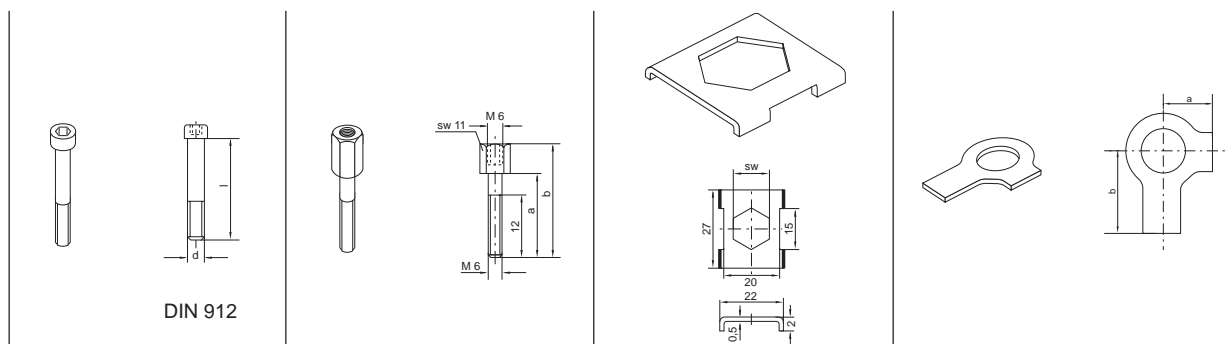

clamp size	socket head		stacking				locking plate ¹⁾		locking washer ²⁾			
	IS B... Order code	dimensions: d x L	AS B... Order code	a	b	m	SW	SB B... Order code	SW	US... Order code	a	b
1	ISA4X (ISB1X)	M 6 x 35	ASA0X (ASB1X)	20	34	M 6	11	SBB1X	11	USA/USB1X	9	18
2	ISB2X	M 8 x 35	ASB2X	20	33	M 8	12	SBB2X	12	USB2X	11	20
3	ISB3X	M 8 x 45	ASB3X	29	44	M 8	12					
4	ISB4X	M 8 x 50	ASB4X	34	49	M 8	12					
5	ISB5X	M 8 x 60	ASB5X	47	62	M 8	12					

¹⁾ The use of stacking screws necessitates the use of locking plates in the construction assembly!

²⁾ When assembling solid rubber clamps, covering plates, hexagon screws and locking washers must be used.
Metal parts also available in stainless steel.

Tube clamps series B – Complete range

Polypropylene – RBP
 Inside smooth – RBPG
 Polyamide 6 – RBN
 Rubber – RBVG*

(As required please exchange standard abbreviation RBP in column for "Order code")

2 clamp halves, weld plate,
cover plate, hex. head bolt

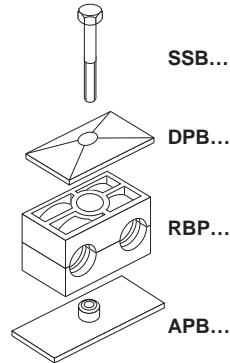

2 clamp halves, weld plate,
cover plate, socket head bolt

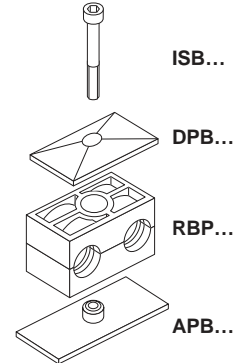

clamp size	Tube O.D. mm	Tube NB	Tube O.D.	Order code	Order code
1	6	G ¹ / ₈	1/4	RBP1-106	RBP3-106
	6.4			RBP1-106.4	RBP3-106.4
	8			RBP1-108	RBP3-108
	8.5			RBP1-109.5	RBP3-109.5
	10			RBP1-110	RBP3-110
	12			RBP1-112	RBP3-112
2	12.7	G ¹ / ₄	1/2	RBP1-212.7	RBP3-212.7
	13.5			RBP1-213.5	RBP3-213.5
	14			RBP1-214	RBP3-214
	15			RBP1-215	RBP3-215
	16			RBP1-216	RBP3-216
	17.2			RBP1-217.2	RBP3-217.2
3	18	G ³ / ₈	5/8	RBP1-218	RBP3-218
	19			RBP1-319	RBP3-319
	20			RBP1-320	RBP3-320
	21.3			RBP1-321.3	RBP3-321.3
	22			RBP1-322	RBP3-322
4	25	G ³ / ₄	1	RBP1-325	RBP3-325
	26.9			RBP1-426.9	RBP3-426.9
	28			RBP1-428	RBP3-428
5	30	G1	1 1/4	RBP1-430	RBP3-430
	32			RBP1-532	RBP3-532
	33.7			RBP1-533.7	RBP3-533.7
	35			RBP1-535	RBP3-535
	38			RBP1-538	RBP3-538
	42	G1 1/4	1 1/2	RBP1-542	RBP3-542

Delivery in unassembled individual components.

*Only with cover plate, hexagon screws and locking washers.

Tube clamps series B – Complete range

Polypropylene – RBP
 Inside smooth – RBPG
 Polyamide 6 – RBN
 Rubber – RBVG*

(As required please exchange standard abbreviation RBP in column for "Order code")

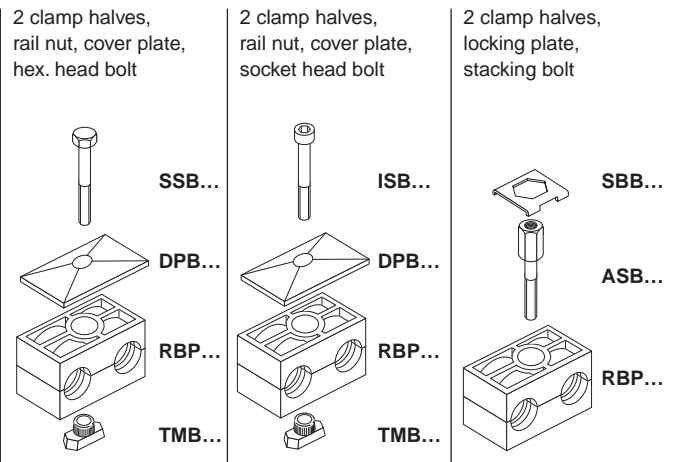

clamp size	Tube O.D. mm	Tube NB	Tube O.D.	Order code	Order code	Order code
1	6	G ¹ / ₈	1/4	RBP4-106	RBP5-106	RBP8-106
	6.4			RBP4-106.4	RBP5-106.4	RBP8-106.4
	8			RBP4-108	RBP5-108	RBP8-108
	9.5			RBP4-109.5	RBP5-109.5	RBP8-109.5
	10			RBP4-110	RBP5-110	RBP8-110
	12		3/8	RBP4-112	RBP5-112	RBP8-112
2	12.7	G ¹ / ₄	1/2	RBP4-212.7	RBP5-212.7	RBP8-212.7
	13.5			RBP4-213.5	RBP5-213.5	RBP8-213.5
	14			RBP4-214	RBP5-214	RBP8-214
	15	G ³ / ₈	5/8	RBP4-215	RBP5-215	RBP8-215
	16			RBP4-216	RBP5-216	RBP8-216
	17.2			RBP4-217.2	RBP5-217.2	RBP8-217.2
	18			RBP4-218	RBP5-218	RBP8-218
3	19	G ¹ / ₂	3/4	RBP4-319	RBP5-319	RBP8-319
	20			RBP4-320	RBP5-320	RBP8-320
	21.3			RBP4-321.3	RBP5-321.3	RBP8-321.3
	22			RBP4-322	RBP5-322	RBP8-322
	25		1	RBP4-325	RBP5-325	RBP8-325
4	26.9	G ³ / ₄		RBP4-426.9	RBP5-426.9	RBP8-426.9
	28			RBP4-428	RBP5-428	RBP8-428
	30			RBP4-430	RBP5-430	RBP8-430
5	32	G1	1 1/4	RBP4-532	RBP5-532	RBP8-532
	33.7			RBP4-533.7	RBP5-533.7	RBP8-533.7
	35			RBP4-535	RBP5-535	RBP8-535
	38	RBP4-538	RBP5-538	RBP8-538		
	42	G1 1/4	1 1/2	RBP4-542	RBP5-542	RBP8-542

Delivery in unassembled individual components.
 *Only with cover plate, hexagon screws and locking washers.

Tube clamps series C (Heavy series) – Components

DIN 3015, part 2

Order code for clamp halves:

 Polypropylene – RCP
 Inside smooth – RCPG⁽¹⁾
 Polyamide 6 – RCN⁽¹⁾
 Rubber – RCVR
 Aluminium – RCA

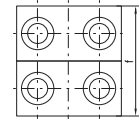
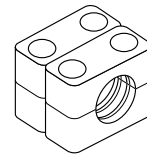
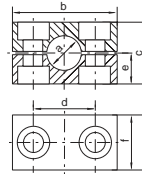
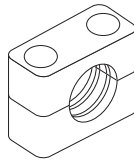
 (Please exchange as required standard abbreviation
 RCP in column for “clamp halves”)

RCPD
 (= 2XRCP...)

clamp size	Tube O.D. mm	Tube NB	Tube O.D.	1 part 2 clamp halves					1 part 4 clamp halves																	
				RCP... Order code	dimensions: b c d e f					RCPD... Order code	dimensions: b c d e f															
1	6	G 1/8	5/16	RCP106X	55	32	33	16	30	RCPD106	55	32	33	16	60											
	8			RCP108X						RCPD108																
	10			RCP110X						RCPD110																
	12			RCP112X						RCPD112																
	12.7	G 1/4	1/2	RCP112.7X						RCPD112.7																
	13.5			RCP113.5X						RCPD113.5																
	14	G 3/8	5/8	RCP114X						RCPD114																
	15			RCP115X						RCPD115																
	16			RCP116X						RCPD116																
	17.2			RCP117.2X						RCPD117.2																
18	RCP118X	RCPD118																								
2	19	G 1/2	3/4	RCP219X	70	48	45	24	30	RCPD219	70	48	45	24	60											
	20			RCP220X						RCPD220																
	21.3			RCP221.3X						RCPD221.3																
	22			RCP222X						RCPD222																
	23	G 3/4	1	RCP223X						RCPD223																
	25			RCP225X						RCPD225																
	26.9	G 3/4	1	RCP226.9X						RCPD226.9																
	28			RCP228X						RCPD228																
	30			RCP230X						RCPD230																
	3			30						G 1						1 1/4	RCP330X	85	60	60	30	30	RCPD330	85	60	60
32		RCP332X	RCPD332																							
33.7		RCP333.7X	RCPD333.7																							
35		RCP335X	RCPD335																							
38		G 1 1/4	1 1/2	RCP338X	RCPD338																					
40				RCP340X	RCPD340																					
42		RCP342X	RCPD342																							
4		38	G 1 1/4	1 1/2	RCP438X	115	90	90	45	45	RCPD438	115	90	90	45	90										
		40			RCP440X						RCPD440															
		42			RCP442X						RCPD442															
	45	RCP445X			RCPD445																					
	48.3	G 1 1/2	2	RCP448.3X	RCPD448.3																					
	50			RCP450X	RCPD450																					
	51	G 2	2	RCP451X	RCPD451																					
	52			RCP452X	RCPD452																					
	55			RCP455X	RCPD455																					
	57			RCP457X	RCPD457																					
	60.3	G 2	2 1/4	RCP460.3X	RCPD460.3																					
	63			RCP463X	RCPD463																					
	65	G 2	2 1/2	RCP465X	RCPD465																					
	70			RCP470X	RCPD470																					

Tube clamps series C (Heavy series) – Components (Continued)

DIN 3015, part 2

Order code for clamp halves:

 Polypropylene – **RCP**
 Inside smooth – **RCPG¹⁾**
 Polyamide 6 – **RCN¹⁾**
 Rubber – **RCVR**
 Aluminium – **RCA**

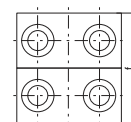
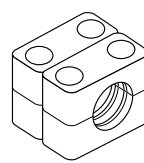
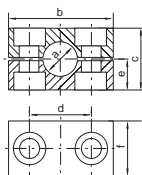
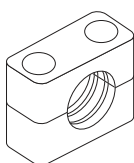
 (Please exchange as required standard abbreviation
 RCP in column for “clamp halves”)

RCPD
 (= 2XRCP...)

clamp size	Tube O.D. mm	Tube NB	Tube O.D.	1 part 2 clamp halves						1 part 4 clamp halves					
				RCP... Order code	dimensions: b c d e f					RCPD... Order code	dimensions: b c d e f				
5	70	G 2½	3	RCP570X	152	120	122	60	60	RCPD570	152	120	122	60	120
	73			RCP573X						RCPD573					
	75			RCP575X						RCPD575					
	76.1			RCP576.1X						RCPD576.1					
	80	RCP580X	RCPD580												
	82.5	RCP582.5X	RCPD582.5												
	88.9	RCP588.9X	RCPD588.9												
90	G 3	3½	RCP590X	RCPD590											
6	90	G 3½	4	RCP690X	205	170	168	85	80	RCPD690	205	170	168	85	160
	97			RCP697X						RCPD697					
	100			RCP6100X						RCPD6100					
	101.6			RCP6101.6X						RCPD6101.6					
	108	RCP6108X	RCPD6108												
	114.3	RCP6114.3X	RCPD6114.3												
	127	G 4	4¼	RCP6127X						RCPD6127					
7	127	G 5	5	RCP7127X	250	200	205	100	90	RCPD7127	250	200	205	100	180
	133			RCP7133X						RCPD7133					
	140			RCP7140X						RCPD7140					
	150	RCP7150X	RCPD7150												
	152.4	G 5½	6	RCP7152.4X						RCPD7152.4					
	159	G 6	6¼	RCP7159X						RCPD7159					
	165.1		6½	RCP7165.1X						RCPD7165.1					
168.3	6⅝		RCP7168.3X	RCPD7168.3											
8	168.3	G 8	6⅝	RCP8168.3X	320	270	265	135	120	RCPD8168.3	320	270	265	135	240
	177.8		7	RCP8177.8X						RCPD8177.8					
	193.7		7⅝	RCP8193.7X						RCPD8193.7					
	203		8⅝	RCP8203X						RCPD8203					
	219.1			RCP8219.1X						RCPD8219.1					
	220			RCP8220X						RCPD8220					

Metal parts also available in stainless steel.

¹⁾ Only sizes 1–4

Tube clamps series C (Heavy series) – Components

DIN 3015, part 2

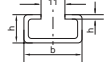
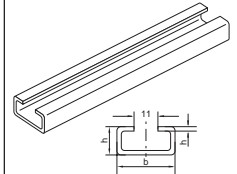
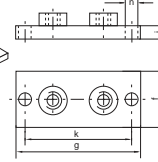
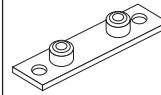
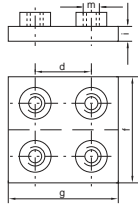
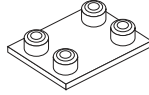
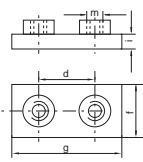
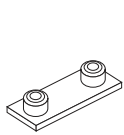

clamp size	weld plate						double weld plate						weld/screw plate						mounting rail		
	AP C... Order code	dimensions: d f g i m					APD C... Order code	dimensions: d f g i m					APL C... Order code	dimensions: g f i k n					TS C... Order code	dim.: b h	
1	APC1X	33	30	73	8	M10	APDC1X	33	60	73	8	M10	APLC1X	113	30	8	85	11	TSC1X (1 meter)	40	22
2	APC2X	45	30	85	8	M10	APDC2X	45	60	85	8	M10	APLC2X	125	30	8	97	11			
3	APC3X	60	30	100	8	M10	APDC3X	60	60	100	8	M10	APLC3X	140	30	8	112	11			
4	APC4X	90	45	140	10	M12	APDC4X	90	90	140	10	M12	APLC4X	190	45	10	160	14			
5	APC5X	122	60	180	10	M16	APDC5X	122	120	180	10	M16	APLC5X	240	60	10	205	18			
6	APC6X	168	80	225	15	M20	APDC6X	168	160	225	15	M20	APLC6X	310	80	15	270	22			
7	APC7X	205	90	270	15	M24	APDC7X	205	180	270	15	M24	APLC7X	370	90	15	320	26			
8	APC8X	265	120	340	25	M30	APDC8X	265	240	340	25	M30	APLC8X	450	120	25	390	33			

Metal parts also available in stainless steel.

Complete programme range please refer to page S28.

Tube clamps series C (Heavy series) – Components

DIN 3015, part 2

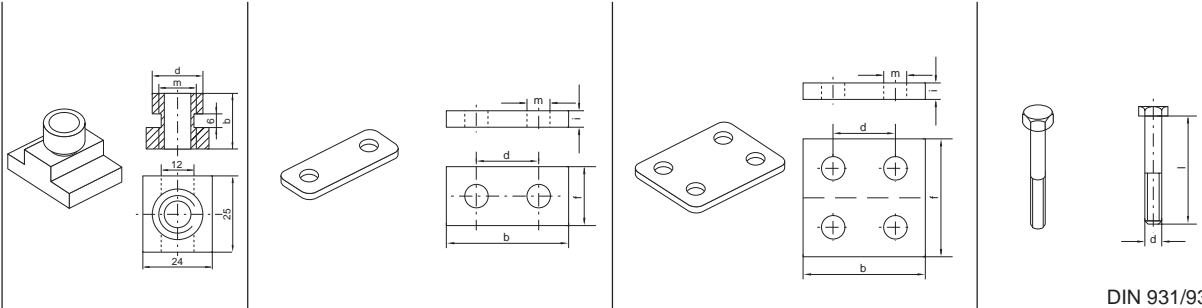

clamp size	rail nut			cover plate					double cover plate					hexagon head				
	TM C... Order code	dimensions: b d m			DP C... Order code	dimensions: b d f i m					DPD C... Order code	dimensions: b d f i m					SS C... Order code	dimensions: d x L
1	TMC1X	20	17.8	M 10	DPC1X	55	33	30	8	11	DPDC1X	55	33	60	8	11	SSC1X	M 10 x 45
2					DPC2X	70	45	30	8	11	DPDC2X	70	45	60	8	11	SSC2X	M 10 x 60
3					DPC3X	85	60	30	8	11	DPDC3X	85	60	60	8	11	SSC3X	M 10 x 70
4	TMC4X	23	19.8	M 12	DPC4X	115	90	45	10	14	DPDC4X	115	90	90	10	14	SSC4X	M 12 x 100
5					DPC5X	152	122	60	10	18	DPDC5X	152	122	120	10	18	SSC5X	M 16 x 130
6					DPC6X	205	168	80	15	22	DPDC6X	205	168	160	15	22	SSC6X	M 20 x 190
7					DPC7X	250	205	90	15	26	DPDC7X	250	205	180	15	26	SSC7X	M 24 x 220
8					DPC8X	320	265	120	25	33	DPDC8X	320	265	240	25	33	SSC8X	M 30 x 300

Metal parts also available in stainless steel.

Tube clamps series C (Heavy series) – Components

DIN 3015, part 2

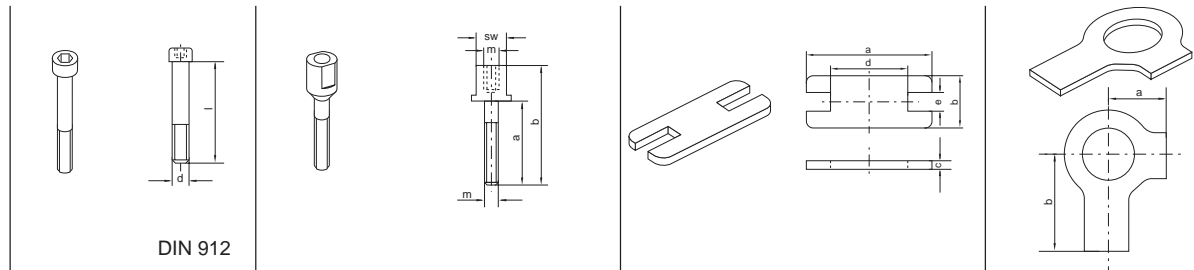

clamp size	socket head IS C...		stacking AS C...					locking plate ¹⁾ SP C...					locking washer ²⁾ US C...		
	Order code	dimensions: d x L	Order code	dimensions: a b m SW				Order code	dimensions: a b c d e				Order code	dimensions: a b	
1	ISC1X	M 10 x 45	ASC1X	25	51	M 10	15	SPC1X	55	30	8	14	15.5	USC1X	13 22
2	ISC2X	M 10 x 60	ASC2X	40	66	M 10	15	SPC2X	70	30	8	26	15.5		
3	ISC3X	M 10 x 70	ASC3X	50	76	M 10	15	SPC3X	85	30	8	41	15.5		
4	ISC4X	M 12 x 100	ASC4X	85	112	M 12	17	SPC4X	115	45	10	69	17.5	USC4X	15 28
5	ISC5X	M 16 x 130	ASC5X	110	146	M 16	21	SPC5X	152	60	10	97	21.5	USC5X	18 32
6	ISC6X	M 20 x 190	ASC6X	155	206	M 20	27	SPC6X	205	80	15	137	27.5	USC6X	21 36
7	ISC7X	M 24 x 220	ASC7X	185	245	M 24	30	SPC7X	250	90	15	169	30.5	USC7X	25 42
8	ISC8X	M 30 x 300	ASC8X	250	330	M 30	36	SPC8X	320	120	25	219	36.5	USC8X	32 52

¹⁾ The use of stacking screws necessitates the use of locking plates in the construction assembly!

²⁾ When assembling solid rubber clamps, covering plates, hexagon screws and locking washers must be used.
 Metal parts also available in stainless steel.

Tube clamps series C – Complete range

Polypropylene – RCP
 Inside smooth – RCPG¹⁾
 Polyamide 6 – RCN
 Rubber – RCVR*
 Aluminium – RCA

(As required please exchange standard abbreviation RCP in column for "Order code")

2 clamp halves, weld plate,
cover plate, hex. head bolt

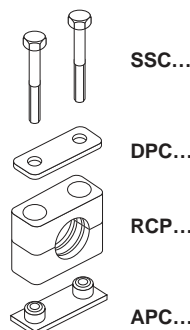

2 clamp halves, weld plate,
cover plate, socket head bolt

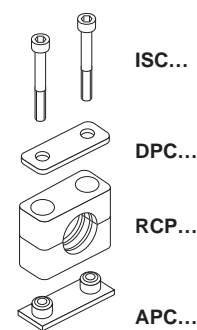

clamp size	Tube O.D. mm	Tube NB	Tube O.D.	Order code	Order code
1	6	G 1/8	5/16	RCP1-106	RCP2-106
	8			RCP1-108	RCP2-108
	10			RCP1-110	RCP2-110
	12			RCP1-112	RCP2-112
	12.7	G 1/4	1/2	RCP1-112.7	RCP2-112.7
	13.5			RCP1-113.5	RCP2-113.5
	14			RCP1-114	RCP2-114
	15			RCP1-115	RCP2-115
	16	G 3/8	5/8	RCP1-116	RCP2-116
	17.2			RCP1-117.2	RCP2-117.2
18	RCP1-118			RCP2-118	
2	19	G 1/2	3/4	RCP1-219	RCP2-219
	20			RCP1-220	RCP2-220
	21.3			RCP1-221.3	RCP2-221.3
	22			RCP1-222	RCP2-222
	23	G 3/4	1	RCP1-223	RCP2-223
	25			RCP1-225	RCP2-225
	26.9			RCP1-226.9	RCP2-226.9
	28			RCP1-228	RCP2-228
30	RCP1-230	RCP2-230			
3	30	G 1	1 1/4	RCP1-330	RCP2-330
	32			RCP1-332	RCP2-332
	33.7			RCP1-333.7	RCP2-333.7
	35	G 1 1/4	1 1/2	RCP1-335	RCP2-335
	38			RCP1-338	RCP2-338
	40			RCP1-340	RCP2-340
42			RCP1-342	RCP2-342	
4	38	G 1 1/4	1 1/2	RCP1-438	RCP2-438
	40			RCP1-440	RCP2-440
	42			RCP1-442	RCP2-442
	45	G 1 1/2	2	RCP1-445	RCP2-445
	48.3			RCP1-448.3	RCP2-448.3
	50			RCP1-450	RCP2-450
	51	G 2	2 1/4	RCP1-451	RCP2-451
	52			RCP1-452	RCP2-452
	55			RCP1-455	RCP2-455
	57	2 1/2	2 1/2	RCP1-457	RCP2-457
	60.3			RCP1-460.3	RCP2-460.3
	63			RCP1-463	RCP2-463
	65			RCP1-465	RCP2-465
70			RCP1-470	RCP2-470	

Continuation see next page ...

Tube clamps series C – Complete range (Continued)

Polypropylene – RCP
 Inside smooth – RCPG¹⁾
 Polyamide 6 – RCN
 Rubber – RCVR*
 Aluminium – RCA

(As required please exchange standard abbreviation RCP in column for "Order code")

2 clamp halves, weld plate,
cover plate, hex. head bolt

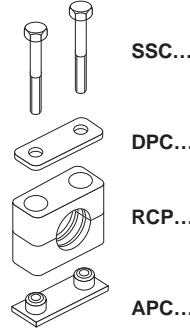

2 clamp halves, weld plate,
cover plate, socket head bolt

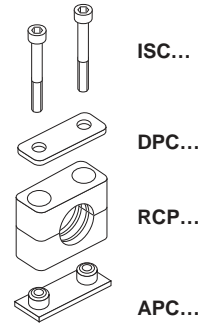

clamp size	Tube O.D. mm	Tube NB	Tube O.D.	Order code	Order code
5	70	G 2½	3	RCP1-570	RCP2-570
	73			RCP1-573	RCP2-573
	75			RCP1-575	RCP2-575
	76.1			RCP1-576.1	RCP2-576.1
	80	G 3	3¼	RCP1-580	RCP2-580
	82.5			RCP1-582.5	RCP2-582.5
	88.9			RCP1-588.9	RCP2-588.9
90			RCP1-590	RCP2-590	
6	90	G 3½	4	RCP1-690	RCP2-690
	97			RCP1-697	RCP2-697
	100			RCP1-6100	RCP2-6100
	101.6			RCP1-6101.6	RCP2-6101.6
	108	G 4	4¼	RCP1-6108	RCP2-6108
	114.3			RCP1-6114.3	RCP2-6114.3
127		5	RCP1-6127	RCP2-6127	
7	127	G 5	5	RCP1-7127	RCP2-7127
	133			RCP1-7133	RCP2-7133
	140			RCP1-7140	RCP2-7140
	150	G 5½	6	RCP1-7150	RCP2-7150
	152.4			RCP1-7152.4	RCP2-7152.4
	159			RCP1-7159	RCP2-7159
	165.1			RCP1-7165.1	RCP2-7165.1
168.3	G 6	6½	RCP1-7168.3	RCP2-7168.3	
8	168.3	G 8	8⅝	RCP1-8168.3	RCP2-8168.3
	177.8			RCP1-8177.8	RCP2-8177.8
	193.7			RCP1-8193.7	RCP2-8193.7
	203			RCP1-8203	RCP2-8203
	219.1			RCP1-8219.1	RCP2-8219.1
	220			RCP1-8220	RCP2-8220

Delivery in unassembled individual components.

¹⁾ Only sizes 1–4

* Only with cover plate, hexagon screws and locking washers (only sizes 1–4).

Tube clamps series C – Complete range

Polypropylene – RCP
 Inside smooth – RCPG¹⁾
 Polyamide 6 – RCN
 Rubber – RCVR*
 Aluminium – RCA

(As required please exchange standard abbreviation RCP in column for "Order code")

2 clamp halves,
 rail nuts, cover plate,
 hex. head bolts

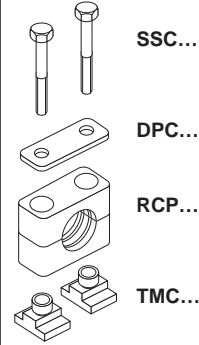

2 clamp halves,
 rail nuts, cover plate,
 socket head bolts

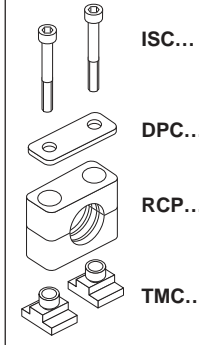

2 clamp halves, locking
 plate, stacking bolts

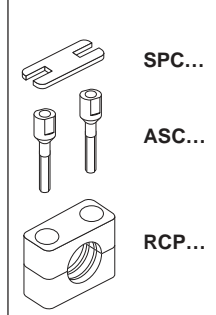

clamp size	Tube O.D. mm	Tube NB	Tube O.D.	Order code	Order code	Order code
1	6	G 1/8	5/16	RCP3-106	RCP4-106	RCP5-106
	8			RCP3-108	RCP4-108	RCP5-108
	10			RCP3-110	RCP4-110	RCP5-110
	12			RCP3-112	RCP4-112	RCP5-112
	12.7	G 1/4	1/2	RCP3-112.7	RCP4-112.7	RCP5-112.7
	13.5			RCP3-113.5	RCP4-113.5	RCP5-113.5
	14			RCP3-114	RCP4-114	RCP5-114
	15			RCP3-115	RCP4-115	RCP5-115
	16	G 3/8	5/8	RCP3-116	RCP4-116	RCP5-116
	17.2			RCP3-117.2	RCP4-117.2	RCP5-117.2
18	RCP3-118			RCP4-118	RCP5-118	
2	19			G 1/2	3/4	RCP3-219
	20	RCP3-220	RCP4-220			RCP5-220
	21.3	RCP3-221.3	RCP4-221.3			RCP5-221.3
	22	RCP3-222	RCP4-222			RCP5-222
	23	G 3/4	1	RCP3-223	RCP4-223	RCP5-223
	25			RCP3-225	RCP4-225	RCP5-225
	26.9			RCP3-226.9	RCP4-226.9	RCP5-226.9
28	RCP3-228	RCP4-228	RCP5-228			
30	RCP3-230	RCP4-230	RCP5-230			
3	30	G 1	1 1/4	RCP3-330	RCP4-330	RCP5-330
	32			RCP3-332	RCP4-332	RCP5-332
	33.7			RCP3-333.7	RCP4-333.7	RCP5-333.7
	35			RCP3-335	RCP4-335	RCP5-335
	38	G 1 1/4	1 1/2	RCP3-338	RCP4-338	RCP5-338
	40			RCP3-340	RCP4-340	RCP5-340
42	RCP3-342	RCP4-342	RCP5-342			
4	38	G 1 1/4	1 1/2	RCP3-438	RCP4-438	RCP5-438
	40			RCP3-440	RCP4-440	RCP5-440
	42			RCP3-442	RCP4-442	RCP5-442
	45			RCP3-445	RCP4-445	RCP5-445
	48.3	G 1 1/2	2	RCP3-448.3	RCP4-448.3	RCP5-448.3
	50			RCP3-450	RCP4-450	RCP5-450
	51			RCP3-451	RCP4-451	RCP5-451
	52	G 2	2 1/4	RCP3-452	RCP4-452	RCP5-452
	55			RCP3-455	RCP4-455	RCP5-455
	57			RCP3-457	RCP4-457	RCP5-457
	60.3			RCP3-460.3	RCP4-460.3	RCP5-460.3
	63	2 1/2	2 1/2	RCP3-463	RCP4-463	RCP5-463
	65			RCP3-465	RCP4-465	RCP5-465
70	RCP3-470			RCP4-470	RCP5-470	

Continuation see next page ...

Tube clamps series C – Complete range (Continued)

Polypropylene – RCP
 Inside smooth – RCPG¹⁾
 Polyamide 6 – RCN
 Rubber – RCVR*
 Aluminium – RCA

(As required please exchange standard abbreviation RCP in column for "Order code")

2 clamp halves, locking plate, stacking bolts

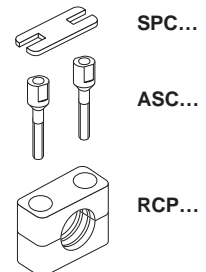

clamp size	Tube O.D. mm	Tube NB	Tube O.D.	Order code
5	70	G 2½	3	RCP5-570
	73			RCP5-573
	75			RCP5-575
	76.1	G 3	3¼ 3½	RCP5-576.1
	80			RCP5-580
	82.5			RCP5-582.5
	88.9			RCP5-588.9
90		RCP5-590		
6	90	G 3½	4	RCP5-690
	97			RCP5-697
	100			RCP5-6100
	101.6	G 4	4¼ 4½ 5	RCP5-6101.6
	108			RCP5-6108
	114.3			RCP5-6114.3
127		RCP5-6127		
7	127	G 5	5 5¼ 5½	RCP5-7127
	133			RCP5-7133
	140			RCP5-7140
	150	G 5½	6 6¼ 6½ 6⅝	RCP5-7150
	152.4			RCP5-7152.4
	159			RCP5-7159
	165.1			RCP5-7165.1
168.3	G 6	RCP5-7168.3		
8	168.3	G 8	6⅝ 7 7⅝ 8⅝	RCP5-8168.3
	177.8			RCP5-8177.8
	193.7			RCP5-8193.7
	203			RCP5-8203
	219.1			RCP5-8219.1
	220			RCP5-8220

Delivery in unassembled individual components.

¹⁾ Only sizes 1–4

* Only with cover plate, hexagon screws and locking washers (only sizes 1–4).

Tube clamps series C – Complete range

Polypropylene – **RCPD**
 Inside smooth – **RCPDG¹**
 Polyamide 6 – **RCND**
 Rubber – **RCVDR***
 Aluminium – **RCAD**

(As required please exchange standard abbreviation RCP in column for "Order code")

4 clamp halves, double weld plate, double cover plate, hex. head bolts

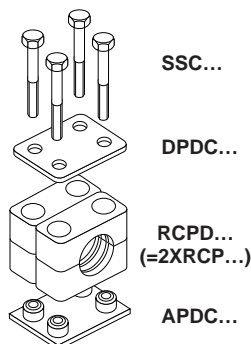

4 clamp halves, double weld plate, double cover plate, socket head bolts

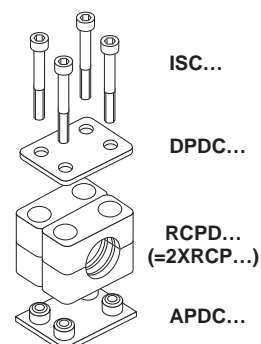

clamp size	Tube O.D. mm	Tube NB	Tube O.D.	Order code	Order code
1	6	G 1/8	5/16	RCPD1-106	RCPD2-106
	8			RCPD1-108	RCPD2-108
	10			RCPD1-110	RCPD2-110
	12			RCPD1-112	RCPD2-112
	12.7	G 1/4	1/2	RCPD1-112.7	RCPD2-112.7
	13.5			RCPD1-113.5	RCPD2-113.5
	14			RCPD1-114	RCPD2-114
	15			RCPD1-115	RCPD2-115
	16	G 3/8	5/8	RCPD1-116	RCPD2-116
	16			RCPD1-116	RCPD2-116
17.2	RCPD1-117.2			RCPD2-117.2	
18	RCPD1-118			RCPD2-118	
2	19	G 1/2	3/4	RCPD1-219	RCPD2-219
	20			RCPD1-220	RCPD2-220
	21.3			RCPD1-221.3	RCPD2-221.3
	22			RCPD1-222	RCPD2-222
	23	G 3/4	1	RCPD1-223	RCPD2-223
	25			RCPD1-225	RCPD2-225
	26.9			RCPD1-226.9	RCPD2-226.9
	28			RCPD1-228	RCPD2-228
30	RCPD1-230	RCPD2-230			
3	30	G 1	1 1/4	RCPD1-330	RCPD2-330
	32			RCPD1-332	RCPD2-332
	33.7			RCPD1-333.7	RCPD2-333.7
	35			RCPD1-335	RCPD2-335
	38	G 1 1/4	1 1/2	RCPD1-338	RCPD2-338
	40			RCPD1-340	RCPD2-340
42	RCPD1-342	RCPD2-342			
4	38	G 1 1/4	1 1/2	RCPD1-438	RCPD2-438
	40			RCPD1-440	RCPD2-440
	42			RCPD1-442	RCPD2-442
	45			RCPD1-445	RCPD2-445
	48.3	G 1 1/2	2	RCPD1-448.3	RCPD2-448.3
	50			RCPD1-450	RCPD2-450
	51			RCPD1-451	RCPD2-451
	52			RCPD1-452	RCPD2-452
	55	G 2	2 1/4	RCPD1-455	RCPD2-455
	57			RCPD1-457	RCPD2-457
	60.3			RCPD1-460.3	RCPD2-460.3
	63			RCPD1-463	RCPD2-463
65	2 1/2	2 1/2	RCPD1-465	RCPD2-465	
70			RCPD1-470	RCPD2-470	

Continuation see next page ...

Tube clamps series C – Complete range (Continued)

Polypropylene – RCPD
 Inside smooth – RCPDG¹⁾
 Polyamide 6 – RCND
 Rubber – RCVDR*
 Aluminium – RCAD

(As required please exchange standard abbreviation RCP in column for "Order code")

4 clamp halves, double weld plate, double cover plate, hex. head bolts

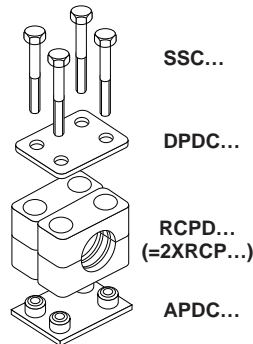

4 clamp halves, double weld plate, double cover plate, socket head bolts

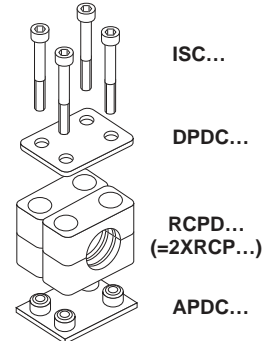

clamp size	Tube O.D. mm	Tube NB	Tube O.D.	Order code	Order code
5	70	G 2½	3	RCPD1-570	RCPD2-570
	73			RCPD1-573	RCPD2-573
	75			RCPD1-575	RCPD2-575
	76.1			RCPD1-576.1	RCPD2-576.1
	80	G 3	3¼	RCPD1-580	RCPD2-580
	82.5			RCPD1-582.5	RCPD2-582.5
	88.9			RCPD1-588.9	RCPD2-588.9
90			RCPD1-590	RCPD2-590	
6	90	G 3½	4	RCPD1-690	RCPD2-690
	97			RCPD1-697	RCPD2-697
	100			RCPD1-6100	RCPD2-6100
	101.6			RCPD1-6101.6	RCPD2-6101.6
	108	G 4	4¼	RCPD1-6108	RCPD2-6108
	114.3			RCPD1-6114.3	RCPD2-6114.3
127		5	RCPD1-6127	RCPD2-6127	
7	127	G 5	5½	RCPD1-7127	RCPD2-7127
	133			RCPD1-7133	RCPD2-7133
	140			RCPD1-7140	RCPD2-7140
	150	G 5½	6	RCPD1-7150	RCPD2-7150
	152.4			RCPD1-7152.4	RCPD2-7152.4
	159	G 6	6¼	RCPD1-7159	RCPD2-7159
	165.1			RCPD1-7165.1	RCPD2-7165.1
168.3	RCPD1-7168.3			RCPD2-7168.3	
8	168.3	G 8	8⅝	RCPD1-8168.3	RCPD2-8168.3
	177.8			RCPD1-8177.8	RCPD2-8177.8
	193.7			RCPD1-8193.7	RCPD2-8193.7
	203			RCPD1-8203	RCPD2-8203
	219.1			RCPD1-8219.1	RCPD2-8219.1
	220			RCPD1-8220	RCPD2-8220

Delivery in unassembled individual components.

¹⁾ Only sizes 1–4

* Only with cover plate, hexagon screws and locking washers (only sizes 1–4).

The fully flexible tube clamp.

Optimum insulation against noise and vibration.

The Primary Material

The fully flexible tube clamps are made out of thermoplastic caoutchouc.

The advantages

Excellent noise insulation and vibration properties. Easy securing also of sensitive tube and pipe installations.

The material properties are appreciably higher than those of comparable vulcanized rubber products.

The Construction Details

The internal surfaces are smooth or grooved. A useful screw safety-device guarantees perfect connections and together with the solid rubber construction eliminates self loosening!

The welding plates, covers and screws are also available in stainless steel.

Low noise and vibration level

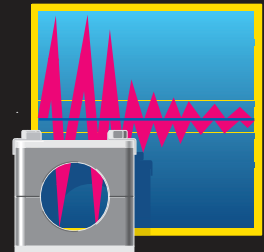

Weather-proof and brittle-resistant



Shape stability with high elasticity



Resistant against many chemicals



Wide temperature applications

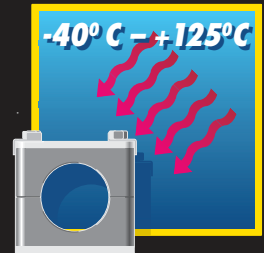

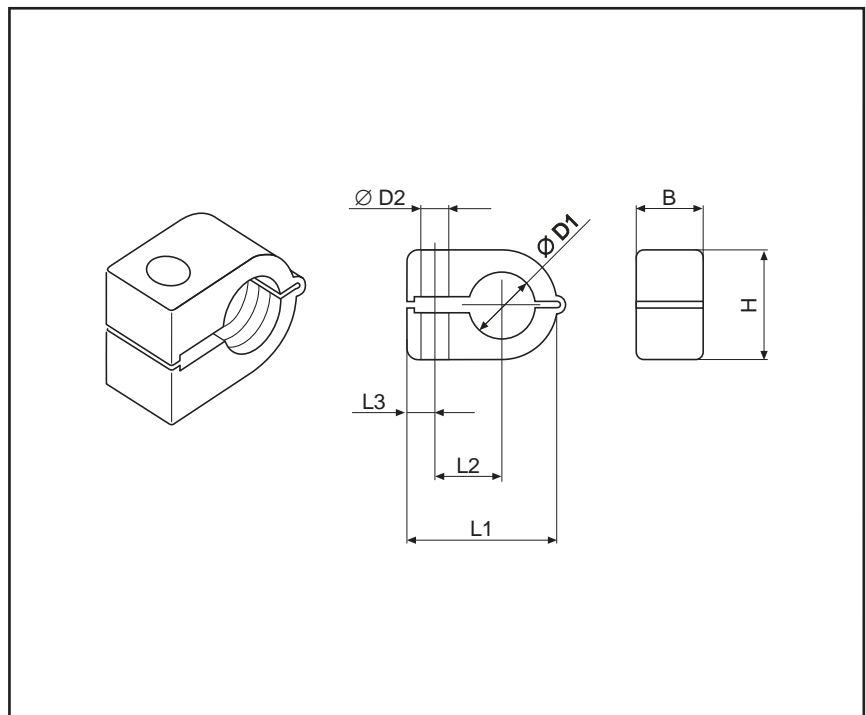
Tube clamps series O

Order code for tube clamps:

 Polypropylene **ROP***

 Polyamide **RON***

 * Supplement with size and tube \varnothing mm.

(e. g. ROP 106X)

Packing standard 200 pieces.

Areas of Application:

- pneumatics
 - automotive technology
 - machine tool industry
 - lubrication
 - naval technologie
- also suitable for cables and hoses.

Clamp-size	Tube \varnothing D1		Inch	Order code Polypropylene ROP	Order code Polyamide RON	L1	L2	L3	B	H	\varnothing D2	
	O.D. mm	Tube NB										
1	6		$1/4$	ROP 106X	RON 106X	22	9	7	14.5	13.5	6.5	
	6.4			ROP 106.4X	RON 106.4X							
	8			ROP 108X	RON 108X							
2	8		$3/8$	ROP 208X	RON 208X	27	11	7	14.5	18.5	6.5	
	9.5			ROP 209.5X	RON 209.5X							
	10	$1/8$		ROP 210X	RON 210X							
	12			ROP 212X	RON 212X							
	12.7			$1/2$	ROP 212.7X							RON 212.7X
3	10	$1/8$	$1/2$	ROP 310X	RON 310X	33	15	7	14.5	23.5	6.5	
	12			ROP 312X	RON 312X							
	12.7			ROP 312.7X	RON 312.7X							
	13.5	$1/4$		ROP 313.5X	RON 313.5X							
	14			ROP 314X	RON 314X							
	15			$5/8$	ROP 315X							RON 315X
4	16		$3/8$	ROP 316X	RON 316X	40	19	6	14.5	30.5	6.5	
	14			$5/8$	ROP 414X							RON 414X
	15			ROP 415X	RON 415X							
	16			ROP 416X	RON 416X							
	17.2			ROP 417.2X	RON 417.2X							
	18			$3/4$	ROP 418X							RON 418X
	19			ROP 419X	RON 419X							
	20			ROP 420X	RON 420X							
	21.3	$1/2$		ROP 421.3X	RON 421.3X							
	22			ROP 422X	RON 422X							

Double-Tube clamps series O

Order code for tube clamps:

Polypropylen **ROPD***

Polyamid **ROND***

*Supplement with size and tube \varnothing mm.
(e. g. ROPD 106X)

*Different diameter on request

Order code for cover plate:

DPO*

*Supplement with size.

Material: Galvanized steel
Stainless steel upon request

Areas of Application:

- pneumatics
 - automotive technology
 - machine tool industry
 - lubrication
 - naval technologie
- also suitable for cables and hoses.

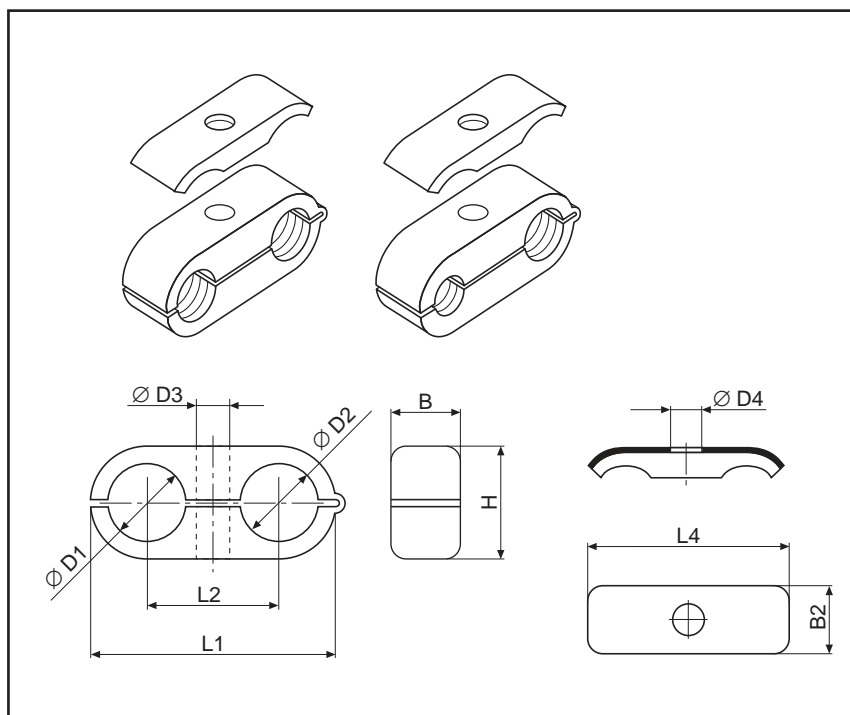

Clamp-size	Tube \varnothing D1/D2			Order code Polypropylene ROPD	Order Code Cover plate DPO	L1	L2	B	H	\varnothing D3	L4	B2	\varnothing D4
	O.D. mm	Tube NB	Inch										
1	6			ROPD 106X	DPO1X	32	18	14.5	13.5	6.5	29	16.3	6.5
	6.4		$1/4$	ROPD 106.4X	DPO1X								
	8			ROPD 108X	DPO1X								
2	8			ROPD 208X	DPO2X	41	22	14.5	18.5	6.5	40	16.3	6.5
	9.5		$3/8$	ROPD 209.5X	DPO2X								
	10	$1/8$		ROPD 210X	DPO2X								
	12			ROPD 212X	DPO2X								
	12.7		$1/2$	ROPD 212.7X	DPO2X								
3	10	$1/8$		ROPD 310X	DPO3X	54	30	14.5	23.5	6.5	50.5	16.5	6.5
	12		$1/2$	ROPD 312X	DPO3X								
	12.7			ROPD 312.7X	DPO3X								
	13.5	$1/4$		ROPD 313.5X	DPO3X								
	14			ROPD 314X	DPO3X								
	15			ROPD 315X	DPO3X								
16		$5/8$	ROPD 316X	DPO3X									
4	14			ROPD 414X	DPO4X	69	38	14.5	30.5	6.5	63	16.5	6.5
	15		$5/8$	ROPD 415X	DPO4X								
	16			ROPD 416X	DPO4X								
	17.2	$3/8$		ROPD 417.2X	DPO4X								
	18			ROPD 418X	DPO4X								
	19		$3/4$	ROPD 419X	DPO4X								
	20			ROPD 420X	DPO4X								
	21.3	$1/2$		ROPD 421.3X	DPO4X								
	22			ROPD 422X	DPO4X								

Hydraulic steel-clamps

Hydraulic steel-clamps

Order code **HSRS-***

W1: steel coating ZN

* please add. $\varnothing D$

HSRS hydraulic steel-clamps are mainly used in the field of building machinery.

The support-block is welded to the machine body or another component either in upend or flat position. The tube-clamp is screwed on.

The robust construction of the clamp has an impact- and vibrationabsorbing effect. The small dimension/ height of the clamp allows hydraulic cables to be fitted later on – e. g. for installing additional equipment to building machinery.

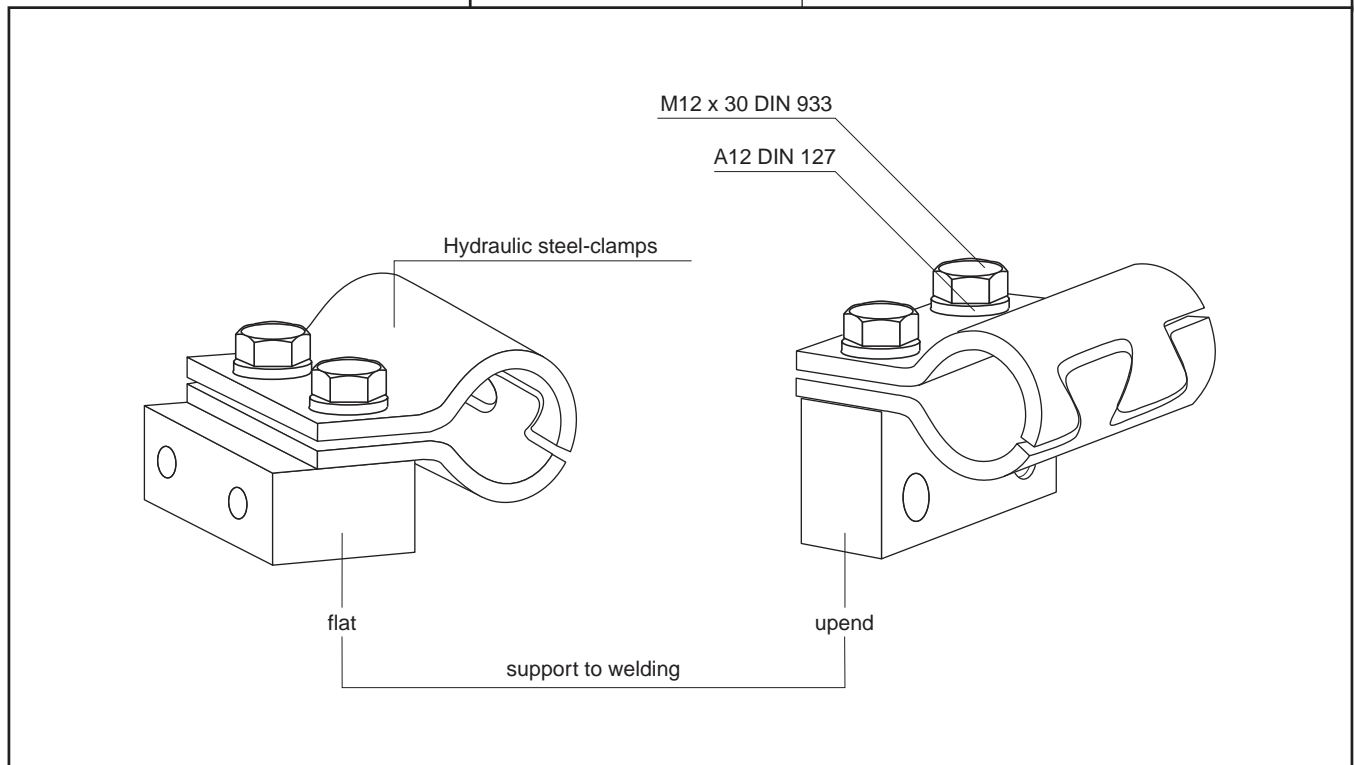
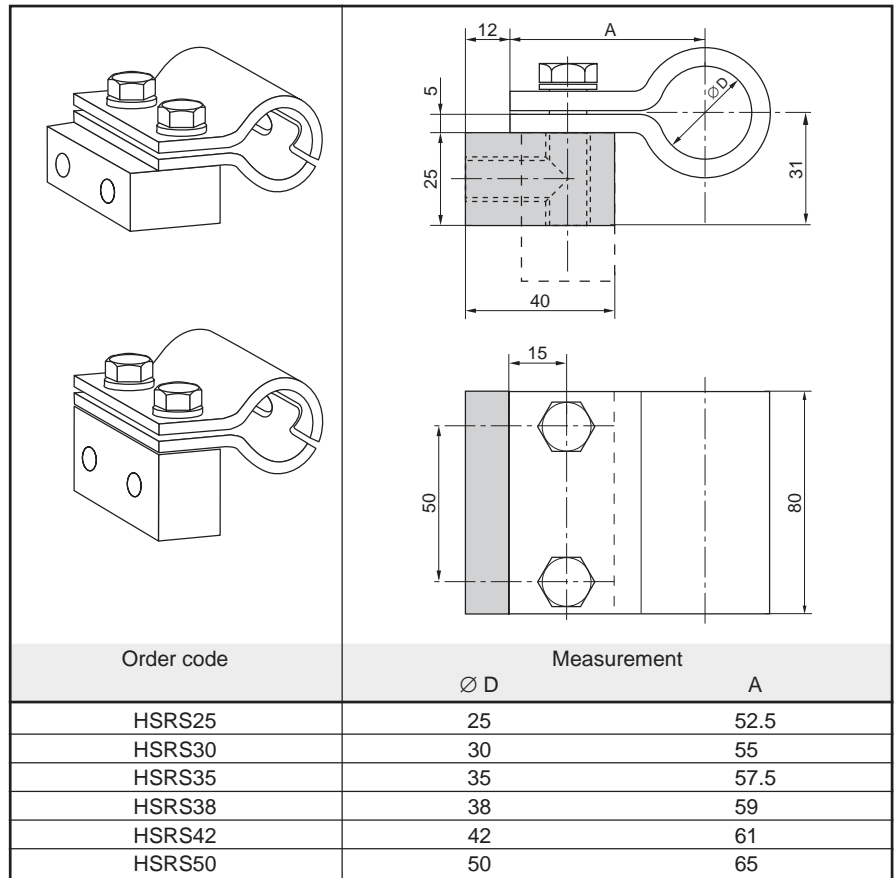

Hydraulic steel-clamps

Elastomere Inlay for HSRS

Order code **EE-***

***** complete outside tube diameter

Hydraulic steel tube clamp HSRS
also available with Elastomere inlay

The advantages:

- complete outside tube diameter
- Safe fastening method even for very sensitive tube and hoses lines
- Only one clamp for different tube diameters

Material:

Santoprene 64 Shore

- high oil and weathering resistance
- temperature stability between -40 °C and +125 °C

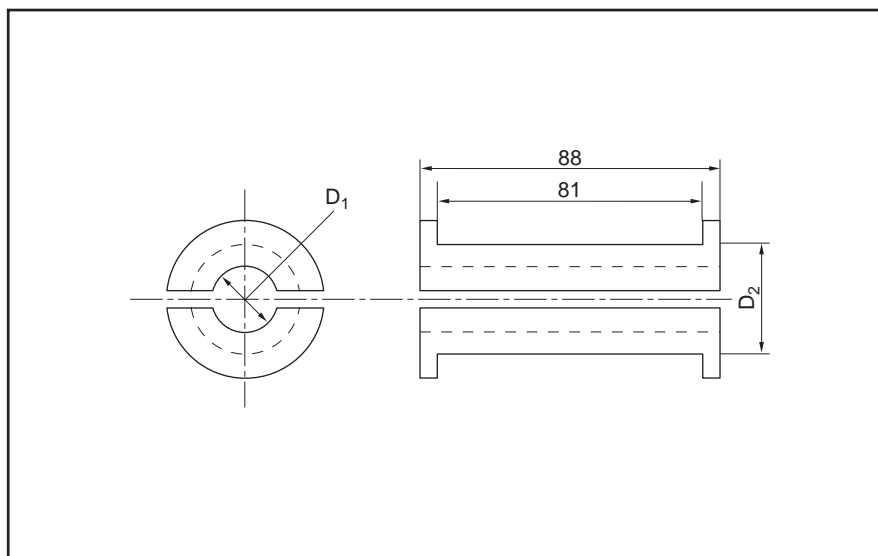

Order code	Nominal size D ₂	mm O.D. D ₁
EE12X	HSRS25	12
EE15X		15
EE20X	HSRS30	20
EE25X	HSRS35	25
EE30X	HSRS42	30
EE35X	HSRS50	35
EE38X		38
EE42X		42

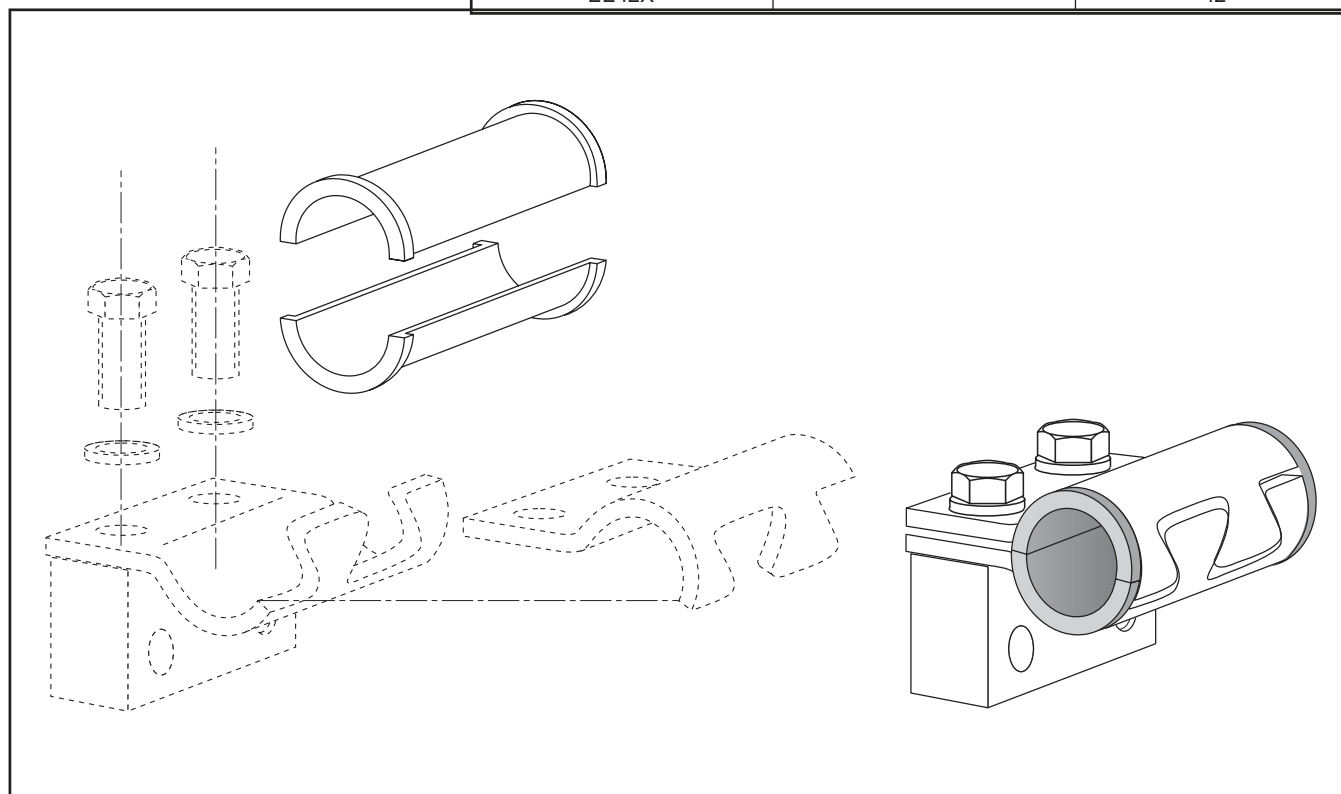



Custom Products



What are Custom Products?

Parker—supplier of your wishes—your special is our standard!

Your idea is our Know-How!

Profit of the advantages of our Custom Products:

- Slogans like “single source“ or “vendor-reduction“ are getting more and more important in industry.
- worldwide availability
- Parker TFDE Custom Products is able to offer almost every type of connector, which is not to be found in our catalogues or price-lists.
- We produce one piece and upwards.

Following examples could be a suggestion, how your problems could be solved in the future.

Jump sizes



One connector can replace several combinations.

- to shorten assembly-time
- to reduce possible leaks and their costs
- to reduce stock

Extra-long connectors



to avoid long tubes
or adapter-combinations

Unconventional configuration of ends



tube and port end
eg: to connect metric and inch tube . . .

Restricted orifice



orifice $\geq 0,3$ mm
(technical clarification about length of reduced bore in accordance to material necessary)

Re-Work of standard connectors



according to customer-instructions and drawings
(shorter threads, bleed adapter, female thread port for test-points gauge connectors)

Brazed parts



for most unusual variations
procedure: silver-brazing

Manifolds



with fixing bores according to customer instructions

Filtration parts



Also possible with your filters.
(We would ask you to let us know required dimensions of your filter)

Milled parts



for narrow spaces

Flange connectors



ISO 6162 (SAE J 518),
according to customer instructions, drawings, etc.

Tubes and tube bends according to your specification possible on your request (incl. preassembled ends)—please let us know length, bend radii, etc.

Industrial Tube Fittings Europe – Alphanumerical index

Order code	Page	Order code	Page	Order code	Page
0107	N47	C6MLO	J19	EGE-NPT	I62
0207	N50	C6MX	K20	EGE-R-ED	I59
0507	N52	C87OMLO	J37	EGEO	I57
1004	H28	C87OMX	K46	EL	I27
1004/210A	H27	C8OMLO	J42	EL-M-ED	I69
1015	H27	C8OMX	K50	EL-R-ED	I70
2107	N48	CC5OLO	J40	ELA/ELAE	O45
210A	H28	CC5OX	K48	EMA1	Q4
2207	N51	CC87OMLO	J38	EMA3	Q8
226	H45	CCCTX	K53	EMA4	Q12
226 BLADES	H45	CCTX	K52	EMK4	N28
2507	N53	CD45M	N10	EMLO	J10
3107	N49	CDM	N9	EMTX	K10
3507	N54	CLO	J43	EO-KARRYMAT	H10
8207	J73	CMTX	K51	EO2-FORM F2	H23
Adapter spare parts	N61	CPM	M70	EOMAT II	H12
AOE4G	N18	CRM	N5	EOMAT III	H16
AOEG	N18	D	I13	ES	M38
AOEL6	J18	DA	I31	ESL	M40
AP	M71	DD45	N15	ESV	L6
AS	M34	DDM	N14	ET	I26
AS	L3	DG 101	P6	ET-M-ED	I67
ASK	L5	DG 102-M	P8	ET-R-ED	I68
ASL	M36	DG 102-R	P7	EV	I25
ASR	M33	DG 103	P9	EV-M-ED	I65
AV 6/42	H44	DG 104-M	P11	EV-R-ED	I66
BAV 6/12	H45	DG 104-R	P10	EVGE-M-ED	I60
BBMTX	K24	DG 105	P12	EVGE-R-ED	I61
BFG	M78	DG 106-M	P14	EVL	I30
BFW	M79	DG 106-R	P13	EVL-M	I75
BFW-3	M80	DG 107	P15	EVL-R	I76
BFW3-G	M86	DG 108	P16	EVT	I29
BFW-G	M81	DIN-CASE	H53	EVT-M	I73
BFW-GI	M82	DKA	I144	EVT-R	I74
BFW-S	M83	DKAZ	I143	EVW	I28
BML/BL	J5	DKI	I140	EVW-M	I71
BMTX	K6	DMTX	K76	EVW-R	I72
BTX	K5	DOZ	I135	EW	I24
BUZ	I130	DPR	I13	EW-M-ED	I63
BUZM	I131	DSVW-M	I103	EW-R-ED	I64
BV 20/25	H47	DSVW-R	I104	F3HMG5	N23
BV 6/18	H46	DV	O34	F3MK4	N38
C3MX	K54	DVGE-M	P18	F3MP4	N58
C3P4	N58	DVGE-R	P17	F3MT4	N55
C3T4	N56	DVWE-M	P20	F3MX	K37
C4OMLO	J41	DVWE-R	P19	F42EDMLO	J30
C4OMX	K49	E	I134	F42EDMX	K32
C5OMLO	J39	E6MK4	N35	F4OHMG5	N24
C5OMX	K47	ED	I136	F4OMX	K33
C6MK4	N31	EGE-M-ED	I58	F5OG	N17

Industrial Tube Fittings Europe – Alphanumerical index

Order code	Page	Order code	Page	Order code	Page
F5OG5	N19	G5G5JG5	N20	K	I21
F5OHAO	N20	G63P4	N60	K6004MX	K85
F5OMLO	J27	G6X	K79	K6PP4MX	K86
F5OMX	K29	G87MLO	J56	KD	I142
F63MP4	N59	GAI-M	I118	KDS	I141
F63MX	K45	GAI-NPT	I120	KH (71)	O38
F642EDMLO	J35	GAI-R	I119	KH (S)	O37
F642EDMX	K41	GE-M	I52	KH 3/2 (S)	O43
F64OMX	K41	GE-M(KEG)	I53	KH 3/2-BSPP(S)	O44
F65OL	J34	GE-M-ED	I46	KH-A-S	M102
F65OMX	K39	GE-NPT	I55	KH-B1V-S	M99
F682EDMLO	J36	GE-R	I49	KH-B2V-S	M100
F682EDMX	K42	GE-R(KEG)	I51	KH-B3V-S	M101
F687OML	J33	GE-R-ED	I47	KH-BSPP (71)	O40
F687OMX	K38	GE-UNF/UN	I54	KH-BSPP (S)	O39
F68OMX	K43	GEO	I45	KH-NPT (71)	O42
F6MK4	N30	GFS	M20	KH-NPT (S)	O41
F6MX	K44	GFS-G	M24	KLO	J12
F82EDMLO	J31	GFS-N	M26	KMMOO	N15
F82EDMX	K34	GG44M	N41	KOR	I36
F87OMLO	J26	GGM	N13	KTX	K14
F87OMX	K28	GHP	H22	L(O)EMQ	M28
F8OHMG5	N25	GM	I132	L(O)HQ	M27
F8OMX	K35	GMA1	Q5	L(O)VQ	M29
FF33M	N45	GMA3	Q9	LD	O35
FF5OMLO	J28	GMA4	Q13	LE-M	I114
FF5OMX	K31	GMTX	K74	LE-M(KEG)	I117
FFF	N6	GR	I16	LE-R	I115
FFM	N4	GZ	I42	LE-R (KEG)	I116
FGM	N8	GZR	I43	LEE-M	I86
FHS	M15	H6MK4	N34	LEE-OR	I85
FHSF	M18	HHP	N16	LEE-R	I87
FLO	J32	HL6	J25	LEE-UNF	I88
FM	I8	HMK4	N26	LOHB3	J62
FMK4	N40	HMLO	J9	LOHL6	J24
FMTX	K36	HMP4	N57	LOHMX6	J67
FNLBA	J69	HMTX	K9	LOHMX6	K91
FNMK4	K39	HMX6	K26	LOHU86	J68
FNML	J63	HP3M	N46	LUBSS/LUBCAN	H43
FNMTX	K87	HP46	N57	M	I12
FORM	I10	HP5ON	N22	MAV	I123
FUS	M16	HPBA	J71	MAV ... MA1	Q7
FUSF	M19	HPM	N16	MAV ... MA3	Q11
FUSM	M17	HVM-B	H8	MAV ... MA4	Q15
G	I15	I-TL	O18	MAVE	I124
G3P4	N60	J6MK4	N36	MAVMD ... MA3	Q11
G4MK4	N37	JMK4	N28	MAVMD ... MA4	Q15
G4MLOSMO	J57	JMLO	J11	MIK-1	H53
G4MX	K73	JMTX	K11	MMO444M	N42
G4MXMO	K80	JX6	K27	MMOM	N15

Industrial Tube Fittings Europe – Alphanumerical index

Order code	Page	Order code	Page	Order code	Page
MMS	N12	PF	M84	RHV50MLOS	O23
MOK	H6	PFB	M85	RHV50MXS	O30
MRO	N11	PFE	M85	RHV82EDMLOS	O25
MTX	K78	PFL	M84	RHV82EDMXS	O32
NIROMONT	H43	PGFS-B	M59	RHZ-M-ED	O15
O-RING	L12	PGFS-S	M62	RHZ-R-ED	O13
O-RINGE	J73–J74	PLCF-B	M97	RHZ42EDMLOS	O22
O-RINGPICK	H50	PNLOBA	J70	RHZ42EDMXS	O29
OR	I137	PNMK4	K29	RHZ50MLOS	O24
OTX	K77	PNMLO	J64	RHZ50MXS	O31
P5ONBA	J71	PNMTX	K88	RHZ82EDMLOS	O26
P5ONM	N21	PORTBOARD A	H53	RHZ82EDMXS	O33
PAFG-90G	M53	PORTBOARD B	H53	RI	I122
PAFG-90L	M57	PPCF	M95	RI-ED	I121
PAFG-90M	M51	PRF	M73	RMTX	K71
PAFG-90X	M55	PSF-B	M92	ROV	I125
PAFG-G	M52	PSFA-B	M90	RRM	J73
PAFG-L	M56	PSFC	M89	RRS	N5
PAFG-X	M54	PSFP	M91	RVP	O17
PAFS-90B	M60	PSR	I13	S	I14
PAFS-90S	M64	PTCF-B	M98	S3MX	K66
PAFS-B	M58	PTR34M	N44	S4OMLO	J50
PAFS-M	M48	PTR44M	N43	S4OMX	K63
PAFS-S	M61	PTRM	N7	S5OMLO	J49
PAFS-U	M49	PWDA	M88	S5OMX	K62
PAFSF-G	M43	PWDS-G	M87	S6MK4	N33
PAFSF-S	M63	R3MX	K72	S6MLO	J21
PAGL-(G/M)	M72	R4OMLO	J54	S6MX	K22
PAR-LOK	H48	R4OMX	K69	S87OMLO	J48
PARFLANGE® 1025	H33	R5OMLO	J53	S87OMX	K61
PARFLANGE® 1040	H35	R5OMX	K68	S8OMLO	J51
PBL	M74	R604MX	K83	S8OMX	K64
PBLR	M75	R6MK4	N32	SAE-CASE	H54
PBT	M76	R6MLO	J22	SBR Löttring	J75
PBTC	M77	R6MX	K23	SHOWCASESS	H55
PCCFF	M69	R6P4MLO	J61	SKA	L7
PCF-B	M94	R6P4MX	K84	SKA-ORB	L10
PCFF	M68	R87OMLO	J52	SKA-RB	L11
PCFF-G	M42	R87OMX	K67	SKAR	L8, L9
PCFF-N	M46	R8OMLO	J55	SMA1	Q7
PDCF-B	M96	R8OMX	K70	SMA3	Q11
PDFS-B	M66	RED	I32	SMA4	Q15
PDFS-G	M65	RHD	O11	SMTX	K65
PDFS-S	M67	RHDI	O16	SV	I22
PDSF-B	M93	RHDMLOS	O20	SWVE-M	I101
PEFF-G	M44	RHDMTXS	O27	SWVE-R	I102
PEFF-N	M47	RHV-M-ED	O14	T	I18
PFF-..S/L	M50	RHV-R-ED	O12	TE-M	I110
PFF-G	M41	RHV42EDMLOS	O21	TE-M(KEG)	I113
PFF-N	M45	RHV42EDMXS	O28	TE-R	I111

Industrial Tube Fittings Europe – Alphanumerical index

Order code	Page	Order code	Page	Order code	Page
TE-R (KEG).....	I112	V6LO	J20	WEMLO	J14
TEE-M	I82	V6MX	K21	WEMTX.....	K16
TEE-OR	I81	V87OMLO	J44	WF5OLO	J29
TEE-R	I83	V87OMX	K55	WFS	M22
TEE-UNF	I84	V8OMLO	J47	WFS-G	M25
TH-M	I98	V8OMX	K58	WGMTX	K75
TH-M-KDS	I97	VEE-M	I90	WH-M	I94
TH-R	I100	VEE-OR	I89	WH-M-KDS	I93
TH-R-KDS	I99	VEE-R	I91	WH-R	I96
TL	J7	VEE-UNF	I92	WH-R-KDS.....	I95
TL Reducing braze sleeve	J8	VH	I133	WJJLO	J17
TPL	J6	VKA	I128	WJJTX	K19
TR	I19	VKA1	Q6	WJLO	J16
Triple-Lok®		VKA3	Q10	WJTX	K18
Spare parts	K93	VKA4	Q14	WLNM	K92
TRMLO	J23	VKAM	I129	WLNML	J72
TRMTX.....	K25	VMTX	K59	WMK4WL4NM	N27
TT4ML	J58	VOMO	H5	WMLO	J13
TT4MX	K81	VSTI M-OR	I126	WMTX	K15
TT8ML	J59	VSTI M/R-ED	I127	WNLO	J15
TTP4ML	J60	W.....	I17	WNTX	K17
TTP4MX	K82	WAS	L4, M37	WSV	I23
TW3L	J72	WE-M	I107	WV	O36
TX	K7	WE-M(KEG)	I106	WZK	H49
V3MX	K60	WE-NPT	I105	XEMQ	M31
V3P4	N59	WE-R	I108	XHML6	J66
V3T4	N56	WE-R(KEG)	I109	XHML6	K90
V4OMLO	J46	WEE-M	I78	XHML0	J65
V4OMX	K57	WEE-OR	I77	XHML0	K89
V5OMLO	J45	WEE-R	I79	XHQ	M30
V5OMX	K56	WEE-UNF	I80	XVQ	M32



Parker Hannifin Corporation

About Parker Hannifin Corporation

Parker Hannifin is a leading global motion-control company dedicated to delivering premier customer service.

A Fortune 500 corporation listed on the New York Stock Exchange (PH), our components and systems comprise over 1,400 product lines that control motion in some 1,000 industrial and aerospace markets.

Parker is the only manufacturer to offer its customers a choice of hydraulic, pneumatic, and electromechanical motion-control solutions. Our Company has the largest distribution network in its field, with over 7,500 distributors serving nearly 400,000 customers worldwide.

Parker's Charter

To be a leading worldwide manufacturer of components and systems for the builders and users of durable goods.

More specifically, we will design, market and manufacture products controlling motion, flow and pressure. We will achieve profitable growth through premier customer service.

Product Information

Customers seeking product information, the location of a nearby distributor, or repair services will receive prompt attention by calling the Parker Product Information Centre.

The Centre can be called toll free from France, Germany, Austria, Switzerland or the United Kingdom. You will be answered by a Parker employee in your own language. Call Freephone: 00800-2727-5374 (00800 C PARKER H).

The Aerospace Group

is a leader in the development, design, manufacture and servicing of control systems and components for aerospace and related high-technology markets, while achieving growth through premier customer service.



The Climate & Industrial Controls Group

designs, manufactures and markets system-control and fluid-handling components and systems to refrigeration, air-conditioning and industrial customers worldwide.



The FluidConnectors Group

designs, manufactures and markets rigid and flexible connectors, and associated products used in pneumatic and fluid systems.



The Seal Group designs, manufactures and distributes industrial and commercial sealing devices and related products by providing superior quality and total customer satisfaction.



The Hydraulics Group

designs, produces and markets a full spectrum of hydraulic components and systems to builders and users of industrial and mobile machinery and equipment.



The Filtration Group

designs, manufactures and markets quality filtration and clarification products, providing customers with the best value, quality, technical support, and global availability.



The Automation Group

is a leading supplier of pneumatic and electromechanical components and systems to automation customers worldwide.



The Instrumentation Group

is a global leader in the design, manufacture and distribution of high-quality critical flow components for worldwide process instrumentation, ultra-high-purity, medical and analytical applications.



FluidConnectors Europe Sales Offices

Parker Hannifin Ges.mbH
Badener Straße 12
A-2700 Wiener Neustadt
Tel: +43 2622 23501
Fax: +43 2622 66212

Parker Hannifin S.A.-N.V.
Parc Industriel Sud
Zone II
23, Rue du Bosquet
B-1400 Nivelles
Tel: +32 67 280900
Fax: +32 67 280999

Parker Hannifin s.r.o.
Dopravaku 723
CZ-184 00 Prague 8
Tel: +420 2 83085221
Fax: +420 2 83085360

Parker Hannifin GmbH
FluidConnectors Group
Am Metallwerk 9
D-33659 Bielefeld
Tel : +49 521 4048-0
Fax: +49 521 4048-4280

Parker Hannifin Danmark A/S
Industrigrenen 11
DK-2635 Ishøj
Tel: +45 43560400
Fax: +45 43733107

Parker Hannifin España S.A
P.I. Las Monjas -
C/.Estaciones, 8
E-28850 Torrejón de Ardoz
(Madrid)
Tel: +34 91 6757300
Fax: +34 91 6757711

Parker Hannifin SA
17, Rue des Bûchillons
Z.I. du Mt Blanc - BP 524
F-74112 Annemasse Cedex
Tel: +33 450878080
Fax: +33 450378685

Parker Hannifin Oy
Ylästöntie 16
FIN-01510 Vantaa
Tel: +358 9 476731
Fax: +358 9 47673200

Parker Hannifin plc
Haydock Park Road
GB-Derby DE24 8JA
Tel: +44 1332 365631
Fax: +44 1332 368038

Parker Hannifin S.p.A.
Via Privata Archimede 1
I-20094 Corsico (MI)
Tel: +39 02 451921
Fax: +39 02 4479340

Parker Sales Ireland Ltd
Bracetown Business Park
Clonee, County Meath
IE-Republic of Ireland
Tel: +353 1 8014010
Fax: +353 1 8014132

Parker Hannifin India Pvt. Ltd.
PLOT EL - 26, MIDC
TTC Industrial Area,
Mahape,
IN-400709 Navi Mumbai
Tel: +91 22 55907081
Fax: +91 22 55907080

Parker Hannifin A/S
Berghagan - P.O. Box 3008
N-1402 Ski
Tel: +47 64911000
Fax: +47 64911090

Parker Hannifin B.V.
Edisonstraat 1
Postbus 340
NL-7570 AH Oldenzaal
Tel: +31 541 585000
Fax: +31 541 585459

Parker Hannifin Sp.z.o.o.
ul. Parowcowa 8B
PL-02-445 Warszawa
Tel: +48 22 8634942
Fax: +48 22 8634944

Parker Hannifin Portugal Lda
Travessa da Bataria,
184 - r/c Drto / 1º Esq.
PT-4450-625 Leça da
Palmeira
Tel: +351 22 9997360
Fax: +351 22 9961527

Parker Hannifin Corporation
Representation Office Moscow
Trehprudny Pereulok 9, bld. 1B,
Office 106
RU-123001 Moscow
Tel: +7 095 2340054
Fax: +7 095 2340528

Parker Hannifin AB
Fagerstagatan 51
Box 8314
S-16308 Spånga-Stockholm
Tel: +46 8 59795000
Fax: +46 8 59795110

Parker Hannifin Corporation
vul. Velyka Vasylykivska 9/2
Office 59
UA-01004 Kiev
Tel: +380 44 2207432
Fax: +380 44 2206534

Internet: <http://www.parker.com>

**For further information on other Parker Products, call the European Product Information Centre
free of charge on 00800 2727 5374.**



Catalogue 4100-5/UK
© 2003 Parker Hannifin
Bonifatius 0603